

DTS 3245/65/85 – 400V / 460V Standard Controller

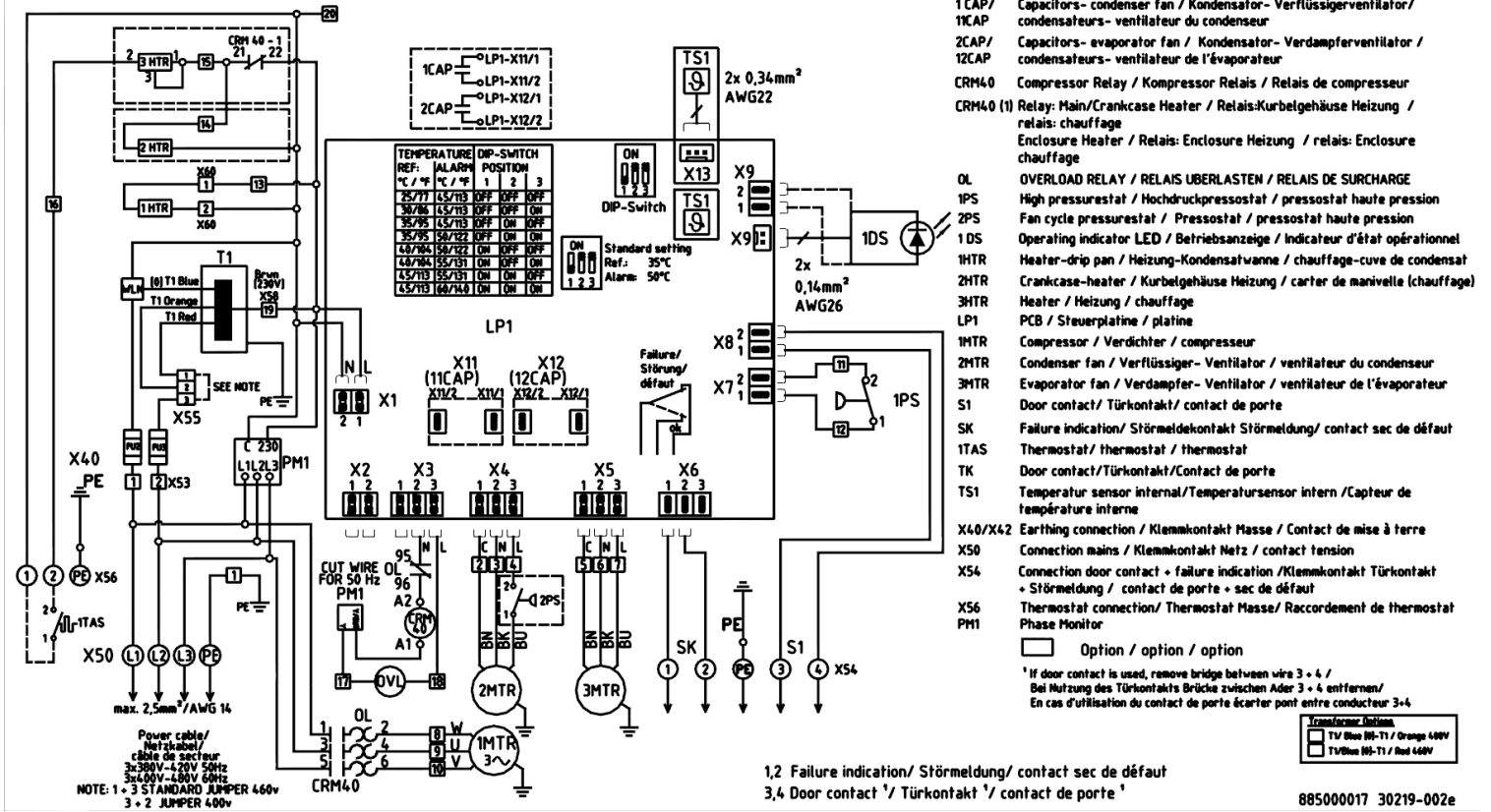

NOTICE	<p>Prior to installation/operation of this unit, read installation/operation manual completely. Installation/operation should only be completed by properly trained personnel</p> <p>Minimum distance to obstructions – 200mm (Exterior) - 100mm (Internal)</p> <p>DO NOT APPLY external voltage to door contact switch. Damage to unit may result.</p>
ACHTUNG	<p>Lesen Sie vor der Installation / dem Betrieb dieses Geräts die Installations- / Bedienungsanleitung vollständig durch. Installation / Betrieb sollte nur von entsprechend geschultem Personal durchgeführt werden</p> <p>Mindestabstand zu Hindernissen - 200 mm (Außen) - 100 mm (Innen)</p> <p>KEINE externe Spannung an den Türkontaktschalter anlegen. Schäden am Gerät können die Folge sein.</p>
NOTICE	<p>Avant l'installation / l'utilisation de cet appareil, lisez le manuel d'installation / d'utilisation complètement. L'installation / opération ne doit être effectuée que par du personnel dûment formé</p> <p>Distance minimale par rapport aux obstacles - 200 mm (supérieur) - 100 mm (interne)</p> <p>NE PAS APPLIQUER de tension externe au commutateur de contact de porte. Des dommages à l'appareil peuvent en résulter.</p>

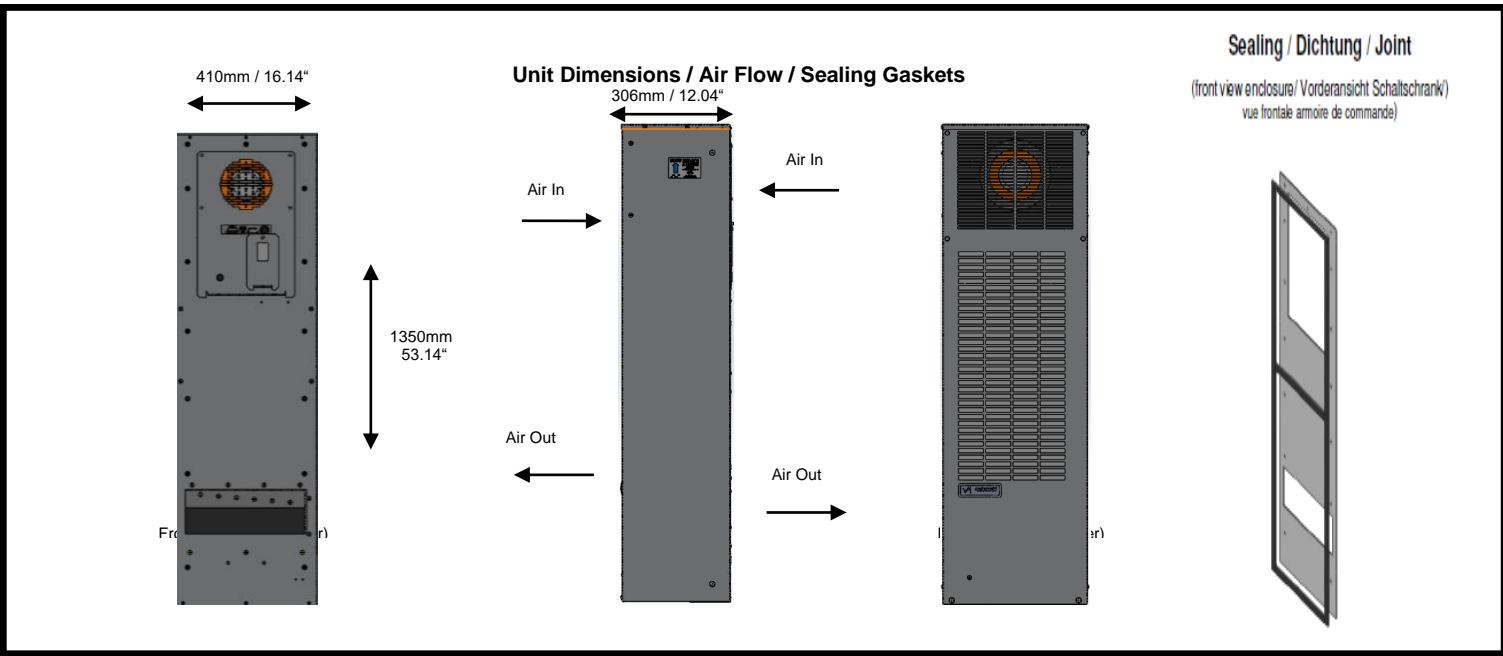

DTS 3245/65/85 – 400V / 460V Standard Controller

Technical Data / Technische Daten / Datos Técnicos

Cooling Data / Kältetechnische Daten / Datos de enfriamiento	DTS 32x5 400V		DTS 32x5 460V
Cooling capacity / Kälteleistung / Capacidad de Enfriamiento (Q ₀) A35°C(95°F)/A35°C(95°F)	3500 W / 12000 BTU/h		
Cooling capacity / Kälteleistung / Capacidad de Enfriamiento (Q ₀) A50°C(122°F)/A40°C(104°F)	2400 W / 8000 BTU/h		
Refrigerant type / Kältemittel-Typ / Tipo de refrigerante	R-134a		
Refrigerant amount / Kältemittelmenge / Cantidad de refrigerante	1200 g / 42.3 oz.		
Adjustable thermostat setting 1TAS (factory set) / Thermostateinstellung (1TAS) (werkseitig eingestellt) / Termóstato ajustable que fija 1TAS (set de fabrica)	+35°C / +95°F		
Failure indication: Enclosure internal temp. (factory set) / Störmeldung: Schaltschrank-Innentemp. (werkseitig eingestellt) / signal de défaut: Température intérieure de l'armoire (pré-réglage en usine)	> +50°C / +122°F		
Ambient air temperature / Umgebungslufttemperatur / Temperatura del aire ambiente	+15°C / +59°F (optional: +0°C / +32°F) . . . +55°C / +131°F		
Air volume, external circulation / Luftvolumenstrom, äußerer Kreislauf / Volumen de aire, circulación externa	1200 m³/h / 706 CFM		
Air volume, internal circulation / Luftvolumenstrom, innerer Kreislauf / Volumen de aire, circulación interna	1200 m³/h / 706 CFM		
Condensation discharge / Kondensatabscheidung / Descarga de la condensación	active evaporation tray; Condensate overflow via hose/ aktiver Verdampfungsbehälter; Kondensatüberlauf über Schlauch/ Cuve d'évaporation active; trop-plein de condensat par tuyau		
Electrical data / Elektrische Kenndaten / Datos Eléctricos			
Voltage / Nennspannung / Voltaje - Frequency / Nennfrequenz / Frecuencia principal - Phase/	400V**	460V	
Mains frequency / Nennfrequenz / Fréquence nominale *	50 Hz	60 Hz	
Operating range / Funktionsbereich / Tolérance	360 V .. 440 V	414 V .. 506 V	
Power consumption / Leistungsaufnahme / Consumo de energía – @ A35°C(95°F)/A35°C(95°F)	1700 W		
Nominal Running Current / Nennlaufstrom / Courant nominal de fonctionnement	3.14 A		
Recommended Maximum Fuse Size – NO HEATER OPTION	6 A (Time Delay Fuse Class CC)		
Recommended Maximum Fuse Size – WITH HEATER OPTION	9 A (Time Delay Fuse Class CC)		
Certifications / Zertifizierungen / Certifications	CE, cULus		
Heating data / Heizungs Kenndaten / Datos de Calefaccion – Non Standard Option			
Internal Thermostat / Interner Thermostat / Termóstato interno	0°-60°C / 32°-140°F		
Heating capacity / Heizleistung / Capacidad de calefacción	900 W / 3072 BTU/h		
Specifications	DTS 3245	DTS 3265	DTS 3285
Weight / Gewicht / Peso	68 kg / 150 lb		
Unit construction / Gerätekonstruktion / Construcción de la Unidad	Sheet steel / Stahlblech / Acier		
Corrosion protection / Korrosionsschutz / Protection anti-corrosion	G90 galvanized, electrostatically powder coated: RAL 7035 or ANSI61, Baked (200°C / 392°F) / Verzinkt, elektrostatisch pulverbeschichtet RAL 7035 oder ANSI61, gebrannt bei 200°C / 392°F / Zingué, laqué à four chaud RAL 7035 ou ANSI61, brûlé avec 200°C / 392°F		304 stainless steel/ Edelstahl/ Acier inoxydable
Protection classification (against the enclosure, under correct operating conditions)/ Schutzart (gegenüber dem Schaltschrank, bei bestimmungsgemäßen Einsatz)/ Clasificación de la protección (Para el gabinete, bajo condiciones de operación correctas)	Type 12 IP 54 (EN 60529)	Type 3R/4 IP 56 (EN 60529)	Type 4/4x IP 56 (EN 60529)

* ID Plate Information / Daten auf Typschild / Information de plaque

**Selectable Voltage, Capacities Reduced 10%

Spare parts / Ersatzteile / Piezas de repuesto

Please order your spare parts only with the *Pfannenber*-parts-number. Bitte geben Sie bei der Bestellung von Ersatzteilen die *Pfannenber*-Teilenummer an. Pida por favor sus partes de repuesto solamente con el número de pieza de *Pfannenber*.

Description	DTS 32x5 400/460V
Internal fan / Interner Lüfter / Ventilador interno	18811100020
External fan / Externer Lüfter / Ventilador externo	18811100020
PCB / Steuerplaine / Platine	18810000012



SCATTERGOOD & JOHNSON LTD

ELECTRICAL ENGINEERING & FLUID CONTROL DISTRIBUTORS

Est.1899

At Scattergood & Johnson Ltd, we pride ourselves on being a technical distributor to specialist industries.

Working with a range of quality product suppliers across a number of specialist markets, we are not your average 'box shifter' - we are your technical and supply chain partner.

We fully support every product we sell - for free! Our internal team and external sales engineers can answer any product or application question, no matter the complexity.

Backing up this technical ability is a range of 50,000+ products available from stock for nationwide next day delivery (same day if required!), or you can collect what you need from any of our trade counters around the UK.

Select your specialist interest below to learn more about how we can help.



Online, In Branch and On the Road - Scattergood & Johnson Ltd, there when you need us.

www.scatts.co.uk