



Electromagnetic Flowmeter



measuring
•
monitoring
•
analysing

MIS

 **IO-Link**



- Accuracy:
$\pm(0.5\% \text{ of reading} + 0.3\% \text{ of full scale})$
- Monitoring, transmitter function, dosing
- Bidirectional measuring
- $p_{\max}: 16 \text{ bar}; t_{\max}: 70^\circ \text{C}$
- Connection flange
3", DN80,4", DN100



SS

KOBOLD companies worldwide:

AUSTRALIA, AUSTRIA, BELGIUM, BULGARIA, CANADA, CHINA, CZECHIA, EGYPT, FRANCE, GERMANY, GREAT BRITAIN, HUNGARY, INDIA, INDONESIA, ITALY, MALAYSIA, MEXICO, NETHERLANDS, PERU, POLAND, REPUBLIC OF KOREA, ROMANIA, RUSSIA, SPAIN, SWITZERLAND, THAILAND, TUNISIA, TURKEY, USA, VIETNAM

KOBOLD Messring GmbH
Nordring 22-24
D-65719 Hofheim/Ts.
Head Office:
+49(0)6192 299-0
+49(0)6192 23398
info.de@kobold.com
www.kobold.com



Description

The new flowmeter MIS was developed for measuring and monitoring medium-sized flow of conductive liquids in pipes. The device operates according to the electromagnetic measurement principle. According to Faraday's Law of magnetic induction, a voltage is induced in a conductor moving through a magnetic field. The electrically conductive measuring agent acts as the moved conductor. The voltage induced in the measuring agent is proportional to the flow velocity and is therefore a value for the volumetric flow. The flowing media must have a minimum conductivity. The induced voltage is picked up by two sensing electrodes which are in contact with the measuring agent and sent to the measuring amplifier.

The flow rate will be calculated based on the cross sectional area of the pipe.

The measurement is not depending on the process liquid and its material properties such as density, viscosity and temperature. Two given outputs can be set to be switch, analogue or frequency. Also a dosing function can be selected, where output 1 is set as switch NPN/PNP/PP and output 2 is set as control input.

Significant Characteristics

- Monitoring, dosing and transmitter function
- Dosing function with external control input
- Coloured, multi-parameter configurable TFT-display, rotatable in 90° steps
- Bidirectional measuring
- Intuitive setup menu via 4 optical touch keys
- 2 configurable outputs (pulse-/frequency-/alarm- and analogue output)
- Grand and resettable totaliser

Areas of Application

- Water tapping
- Water treatment
- Water distribution network (leakage detection management)
- Watering
- Waste water treatment
- Filtration systems (e.g. reverse osmosis and ultrafiltration)
- Industrial applications

Technical Details

Measurement process: electromagnetic
Range: see flow specific values
Media: conductive fluids
Minimum conductivity: $\geq 20 \mu\text{S/cm}$
Max. medium viscosity: $70 \text{ mm}^2/\text{s}$
Max. pressure: 16 bar
Accuracy: $< \pm(0.5\% \text{ of reading} + 0.3\% \text{ of full scale})^*$
Repeatability: $\pm 0.2\% \text{ of full scale}$

Response time flow t_{90}
(alarm output / pulse output): $< 250 \text{ ms}$
Mounting position: in all directions
In-/outlet: $5 \times \text{DN}/3 \times \text{DN}$
Pressure drop (max. at 3 m/s): 25 mbar
Handling: 4 optical touch fields, useable with hand gloves
Housing: aluminium, powder coated, display screen PMMA

Wetted parts

Connection: steel ASTM A105, paint coated (Corrosivity category C4M)
Lining: NBR (others on request)
Electrodes: Hastelloy® C276
Protection: IP 67
Media temperature: $-10^\circ\text{C} \dots +70^\circ\text{C}$
Ambient temperature: $-10^\circ\text{C} \dots +60^\circ\text{C}$

Electrical data

Supply voltage: 19 - 30 V_{DC} , internal power consumption max. 200 mA
Display: TFT display, 128x128 pixels, 1.4" display orientation in 90° steps adjustable
Display repetition rate: 0.5 ... 10 s, adjustable
Pulse output: Push-Pull, freely scalable, configurable for partial and accumulated totaliser
Frequency output: Push-Pull, freely scalable, 2 kHz @ overflow
 $f_{\text{min}} @ \text{FS} = 50 \text{ Hz}$
 $f_{\text{max}} @ \text{FS} = 1000 \text{ Hz}$
Alarm output: NPN, PNP, Push-Pull, configurable max. 30 V_{DC} , max. 200 mA short-circuit proof
Analogue output: active, 3 wire, 0(4)-20 mA, max. load 500 Ω or 0(2)-10 V_{DC} , ($R_i = 500 \Omega$)
Control input: active signal U_{high} max. 30 V_{DC}
 $0 < \text{Low} < 10 V_{\text{DC}}$
 $15 V_{\text{DC}} < \text{High} < V_s$
Dosing function: Dosing output OUT2: Push-Pull, High active
Control input OUT1: START/STOP 0,5 s $< t_{\text{high}} < 4 \text{ s}$
RESET $t_{\text{high}} > 5 \text{ s}$
Electrical connection: plug M12x1, 4-pin

* Under reference conditions: media temperature: $15^\circ\text{C} \dots 30^\circ\text{C}$, 1 cSt, 500 $\mu\text{S/cm}$, 1 bar
ambience temperature: $15^\circ\text{C} \dots 30^\circ\text{C}$

Flow Specific Values

DN	Size		Measuring range (m ³ /h)
		ASME	
40		1½"	0.2 ... 45
50		2"	0.3 ... 63
65		2½"	0.4 ... 100
80		3"	0.6 ... 160
100		4"	1.0 ... 250
125		5"	1.6 ... 400
150		6"	2.4 ... 600
200		8"	4.0 ... 1000

Configuration of outputs

Output 1 (OUT1, PIN 4)	Output 2 (OUT2, PIN 2)
Analogue output 4-20 mA	Analogue output 4-20 mA
Analogue output 0-20 mA	Analogue output 0-20 mA
Analogue output 2-10 V	Analogue output 2-10 V
Analogue output 0-10 V	Analogue output 0-10 V
Switching output NPN/PNP/PP	Switching output NPN/PNP/PP
Pulse output PP	Pulse output PP
Frequency output PP	Frequency output PP
Communication mode M12 COM	
Communication mode IO-Link	
Control input	
Control input dosing function	Dosing output

IO-Link specification

Manufacturer ID: 1105 (decimal), 0 x 0451 (hex)
 Manufacturer name: Kobold Messring GmbH
 IO-Link specification: V1.1
 Bitrate: COM3
 Minimal cycle time: 1,1 ms
 SIO-Mode: yes (OUT1 in configuration IO-Link)
 Block parameterisation: yes
 Operational readiness: 10 s
 Max. cable length: 20 m

Electrical Connection MIS

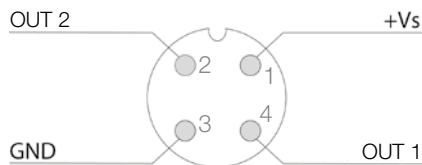

Order Details (Example: MIS-H 330B1 HH 100)

Model	Material lining	Flange type/size	Material process connection	Measuring and earthing electrodes	Transmitter mounting
MIS-	H = hard rubber X ¹⁾ = acc. to specification	330B = DN80 PN16 form A DIN EN 1092-1 335B = DN100 PN16 form A DIN EN 1092-1 208R = 3" Class 150 FF ASME B16.5-2003 210R = 4" Class 150 FF ASME B16.5-2003 XXXX = acc. to specification	1 = steel, paint coated	HH = Hastelloy® XX ²⁾ = acc. to specification	100 = integrated

¹⁾ Possible linings on request: EPDM, soft rubber and PTFE

²⁾ On request are following available: platinum, stainless steel, tantal, titanium

Dimensions [mm]

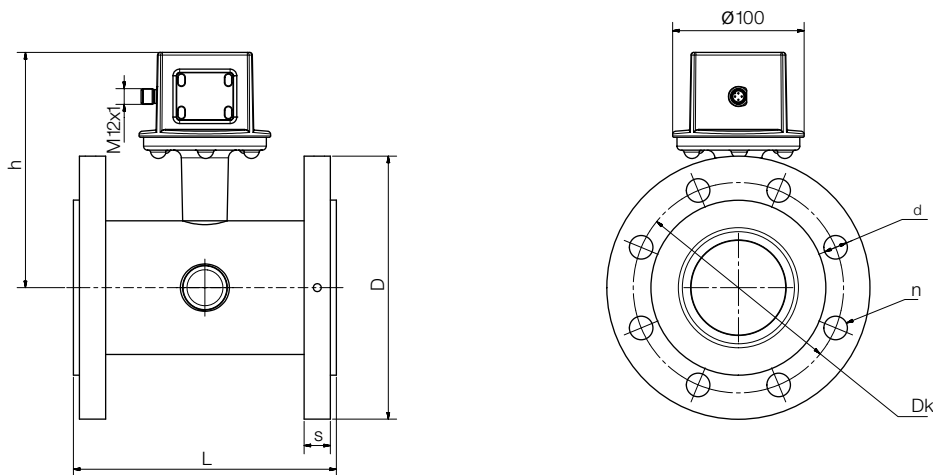

	Nominal diameter	h	L	D	s	Dk	d	n
DIN	DN80	179	200	200	20	160	18	8
	DN 100	186	250	220	22	180	18	8
	DN 150	211	300	285	22	240	22	8
	DN 200	263	350	340	24	295	22	12
ASME	3"	179	200	190	26	152.4	19	4
	4"	186	250	230	27	190.5	19	8
	6"	211	300	279	31	241.3	22.2	8
	8"	263	350	343	34	298.4	22.2	8

Weight

Nominal size		Pressure rating	NBR lining
[mm]	[Inch]		Weight [kg]
80	3	PN16 / Cl. 150	12
100	4	PN16 / Cl. 150	15.6
150	6	PN16 / Cl. 150	26.4
200	8	PN16 / Cl. 150	48.4



Measuring Mode, Display Layout »Single« configurable

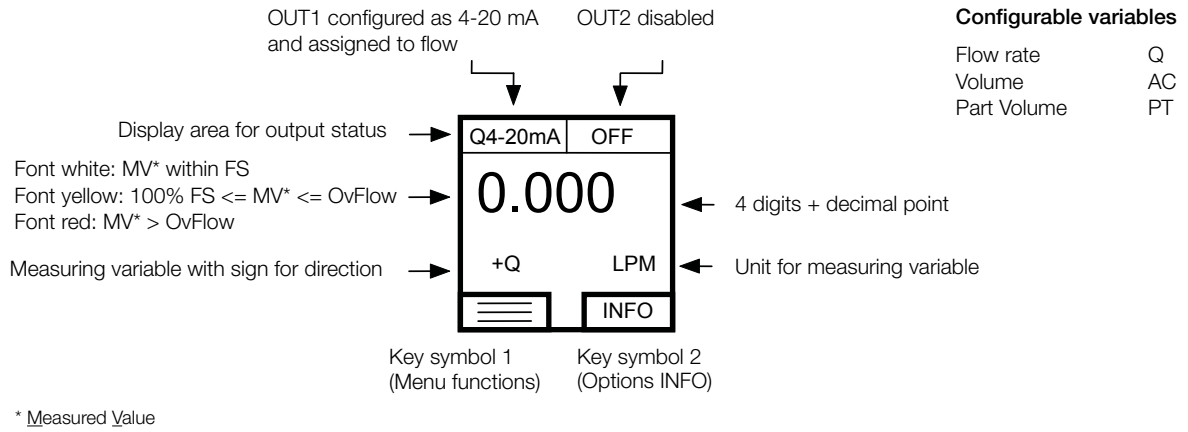

Measuring Mode, Display Layout »Dual« configurable

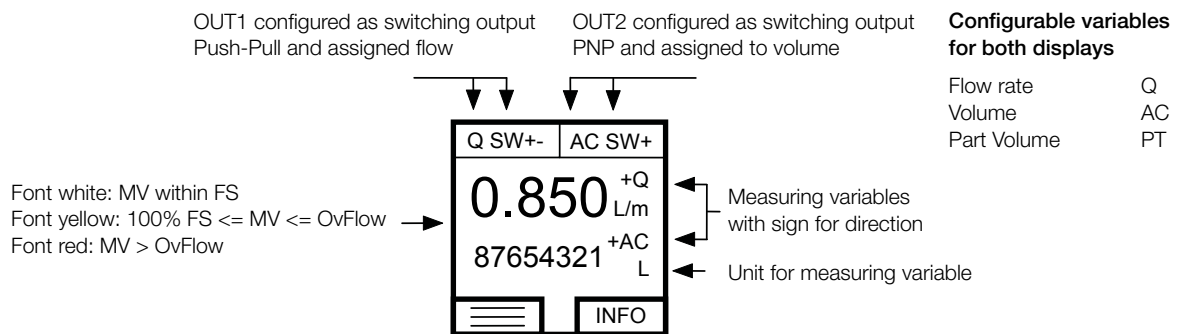

OUT1 configured as Pulse output Push-Pull and assigned to Part Volume OUT2 configured as analogue output 4-20 mA and assigned to flow rate

