



FFU

NON-CONTACT FLOW MEASUREMENT

Flow sensors

SICK
Sensor Intelligence.

NON-CONTACT FLOW MEASUREMENT



Product description

The non-contact FFU ultrasonic flowmeter detects the flow volume of conductive and non-conductive liquids. Swimming against the current requires more strength than with the current – this is the simple fact on which ultrasonic flow measurement according to the phase difference process is based. Its compact design enables the device to be used in a wide range of applications, including

those with limited space. This sensor with an enclosure rating of IP67 features a seal-free sensor design with high-quality polyphenylsulfone (Ultrason® P), which not only makes it possible to use the device in harsh ambient conditions, but also ensures high process reliability. The large cleartext display also helps provide simple, fast, and hassle-free commissioning.

At a glance

- Flow sensor for conductive and non-conductive liquids
- Compact design with no moving parts
- Process temperature up to 80 °C, process pressure up to 16 bar
- High chemical resistance due to seal-free sensor design
- Large display with membrane keyboard
- Integrated empty tube detection

Your benefits

- Maintenance-free flow sensor; reduces maintenance costs
- Adjustable measuring ranges, reduced number of variants
- Can be used for conductive and non-conductive liquids, reducing both the number of variants and storage costs
- Straight measuring tube reduces pressure loss, thus reducing energy costs
- Sensor without seals increases process reliability and availability
- Flexible measuring device for all industries



Additional information

Detailed technical data	3
Type code	4
Ordering information	5
Dimensional drawings	6
Connection type and diagram	8
Recommended accessories	8

→ www.sick.com/FFU

For more information, simply enter the link or scan the QR code and get direct access to technical data, CAD design models, operating instructions, software, application examples, and much more.



Detailed technical data

Features

	DN 10	DN 15	DN 20	DN 25
Medium	Fluids			
Nominal diameter measuring tube (DN)	DN 10	DN 15	DN 20	DN 25
Process temperature	0 °C ... +80 °C			
Process pressure	Max. 16 bar		Max. 10 bar	

Performance

	DN 10	DN 15	DN 20	DN 25
Minimum flow	≤ 0.3 l/min	≤ 0.9 l/min	≤ 3.5 l/min	≤ 5 l/min
Maximum flow	≤ 21 l/min	≤ 36 l/min	≤ 60 l/min	≤ 240 l/min
Inlet zone	10 cm	30 cm	40 cm	40 cm
Output zone	0 cm	5 cm	10 cm	20 cm
Conductivity	No limitation			
Accuracy of sensor element	2 % (of final value) ¹⁾ 1 % (of reading ± 3 mm/s (with calibration report)) ¹⁾ (depending on type)			
Repeatability	≤ 0.5 %			
Resolution	0.003 l/min	0.006 l/min	0.012 l/min	0.03 l/min

¹⁾ Reference condition: Water, zero gas, measuring tube completely full, no cavitation, temperature of medium 20 °C, ambient temperature 20 °C ... 25 °C, compliance with inlet and outlet zones, warm-up time for electronics: 30 min.

Mechanics

	DN 10	DN 15	DN 20	DN 25
Process connection	G ½ ½" NPT Clamp (DIN 11864-3) (depending on type)	G ¾ ¾" NPT Clamp (DIN 11864-3) (depending on type)	G 1 1" NPT Clamp (DIN 11864-3) (depending on type)	G 1 ¼ 1 ¼" NPT Clamp (DIN 11864-3) (depending on type)
Wetted parts	PPSU			
Housing material	PPSU			
Enclosure rating	IP 67			
Weight	340 g	350 g	420 g	460 g

Electronics

Supply voltage	18 V DC ... 30 V DC ¹⁾
Residual ripple	≤ 5 V _{pp} ²⁾
Power consumption	≤ 180 mA ³⁾
Initialization time	≤ 5 s
Protection class	III
Electrical connection	Round connector M12 x 1, 5-pin / M12 round connector x 1, 8-pin (depending on type)

¹⁾ All connections are polarity protected. All outputs are overload and short-circuit protected.

²⁾ May not exceed or fall below V_s tolerances.

³⁾ Without load.

⁴⁾ There are 100 mA for each output pnp and npn available.

⁵⁾ Analog output and display.

Output signal	Analog output: 4 mA ... 20 mA, 0 mA ... 20 mA current flow and temperature, 1 pulse/status output: PNP/NPN-transistor output for flow rate meter, empty pipe detection, flow monitoring, dosing output, flow direction (dependent on type) ¹⁾ Analog output: 4 mA ... 20 mA, 0 mA ... 20 mA current flow and temperature, 2 pulse/status output: PNP/NPN-transistor output for flow rate meter, empty pipe detection, flow monitoring, 1 switching input for dosing and counter reset ¹⁾ (depending on type)
Impuls/frequency output	0 kHz ... 10 kHz
Puls width	≤ 1 s
Signal voltage HIGH	V _s - 2 V
Signal voltage LOW	≤ 2 V
Output current	< 100 mA ⁴⁾
Inductive load	1 H
Capacitive load	100 nF
Response time	Filter off 100 ms, filter low 300 ms, filter medium 1 s, filter strong 4.2 s ⁵⁾
Output load	< 500 Ohm
Lower signal level	3.8 mA ... 4 mA
Upper signal level	20 mA ... 20.5 mA

¹⁾ All connections are polarity protected. All outputs are overload and short-circuit protected.

²⁾ May not exceed or fall below V_s tolerances.

³⁾ Without load.

⁴⁾ There are 100 mA for each output pnp and npn available.

⁵⁾ Analog output and display.

Ambient data

Ambient operating temperature	0 °C ... +60 °C
Ambient storage temperature	0 °C ... +70 °C

Type code

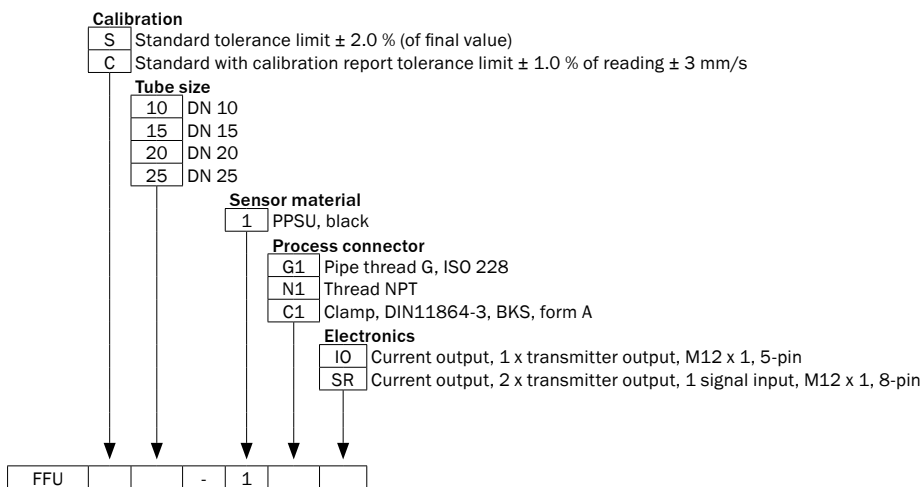

Not all variations of the type code can be combined!

Ordering information

- **Process pressure:** max. 16 bar
- **Nominal diameter measuring tube:** DN 10
- **Maximum flow:** 0 l/min ... 21 l/min

Process connection	Type	Part no.
G ½	FFUS10-1G1IO	6041737
	FFUS10-1G1SR	6043743
½" NPT	FFUS10-1N1IO	6047868
	FFUS10-1C1IO	6049101
Clamp (DIN 11864-3)	FFUC10-1C1SR	6053120
	FFUC10-1G1IO	6049016
G ½	FFUC10-1G1SR	6052236
	FFUC10-1N1IO	6058261
½" NPT	FFUS10-1N1SR	6050786

- **Process pressure:** max. 16 bar
- **Nominal diameter measuring tube:** DN 15
- **Maximum flow:** 0 l/min ... 36 l/min

Process connection	Type	Part no.
G ¾	FFUS15-1G1IO	6041249
	FFUS15-1G1SR	6043744
¾" NPT	FFUS15-1N1IO	6047869
	FFUS15-1C1IO	6045162
Clamp (DIN 11864-3)	FFUC15-1C1SR	6050189
	FFUC15-1G1IO	6049017
G ¾	FFUC15-1G1SR	6052237
	FFUS15-1N1SR	6060235

- **Process pressure:** max. 10 bar
- **Nominal diameter measuring tube:** DN 20
- **Maximum flow:** 0 l/min ... 60 l/min

Process connection	Type	Part no.
G 1	FFUS20-1G1IO	6041738
	FFUS20-1G1SR	6043745
1" NPT	FFUS20-1N1IO	6047870
	FFUS20-1C1IO	6049061
Clamp (DIN 11864-3)	FFUC20-1C1SR	6053121
	FFUC20-1G1IO	6049018
G 1	FFUC20-1G1SR	6052238
	FFUC20-1N1IO	6058038

- **Process pressure:** max. 10 bar
- **Nominal diameter measuring tube:** DN 25
- **Maximum flow:** 0 l/min ... 240 l/min

Process connection	Type	Part no.
G 1 ¼	FFUS25-1G1IO	6041739
	FFUS25-1G1SR	6043746

Process connection	Type	Part no.
1 ¼" NPT	FFUS25-1N1IO	6044996
	FFUS25-1N1SR	6049566
Clamp (DIN 11864-3)	FFUS25-1C1IO	6044523
	FFUC25-1C1SR	6050188
G 1 ¼	FFUC25-1G1IO	6049019
	FFUC25-1G1SR	6052239
1 ¼" NPT	FFUC25-1N1IO	6054505
Clamp (DIN 11864-3)	FFUS25-1C1SR	6052255

Dimensional drawings (Dimensions in mm (inch))

DN 10, G ½

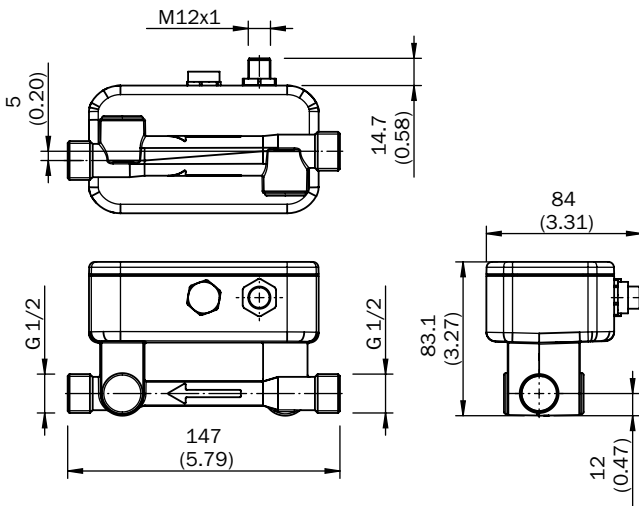

DN 10, ½" NPT

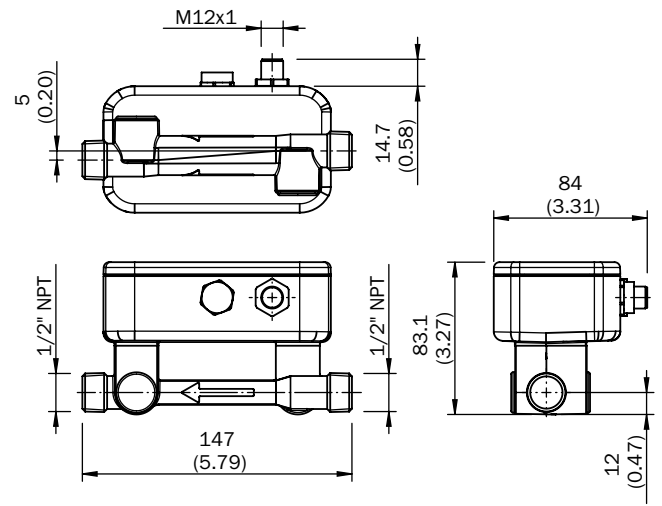

DN 10, Clamp (DIN 11864-3)

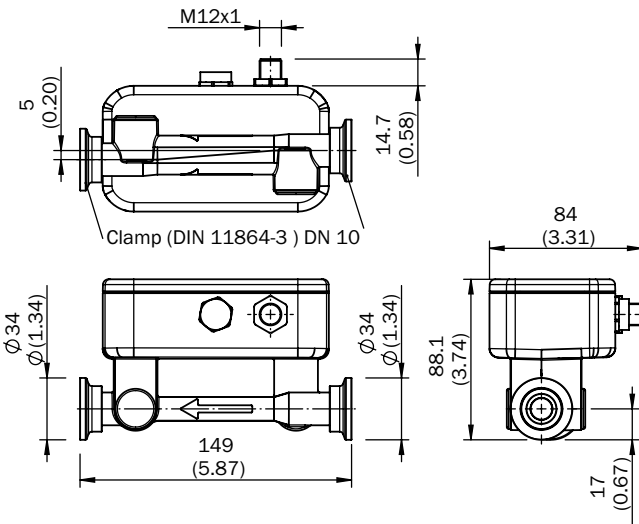

DN 15, G ¾

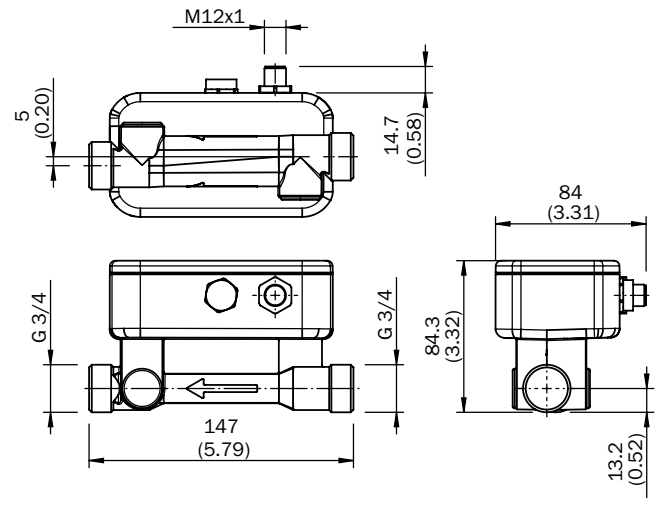

DN 15, 3/4" NPT

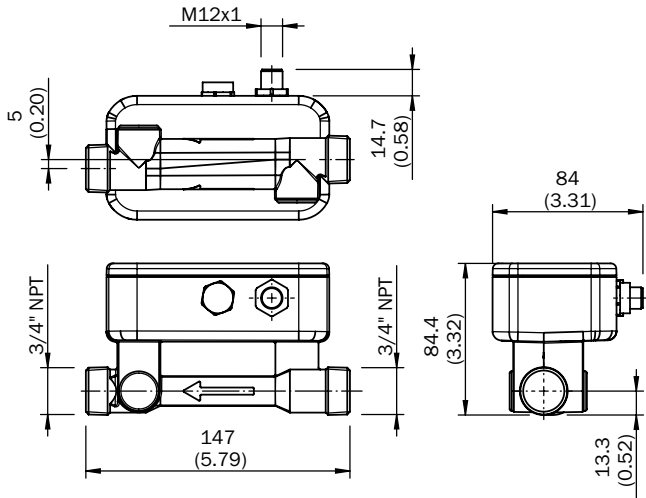

DN 15, Clamp (DIN 11864-3)

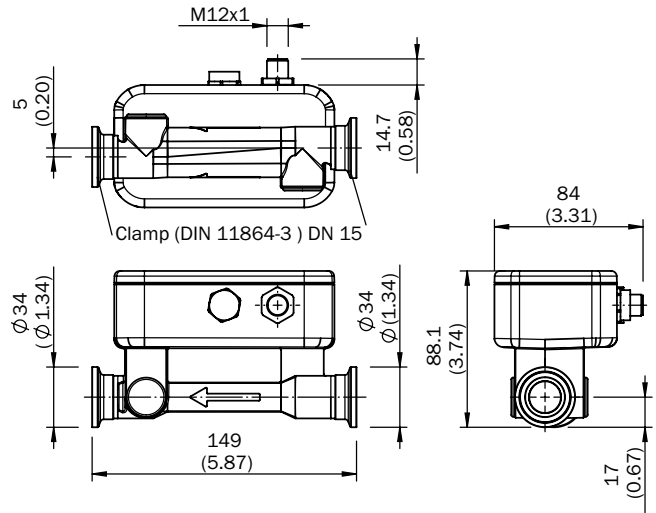

DN 20, G 1

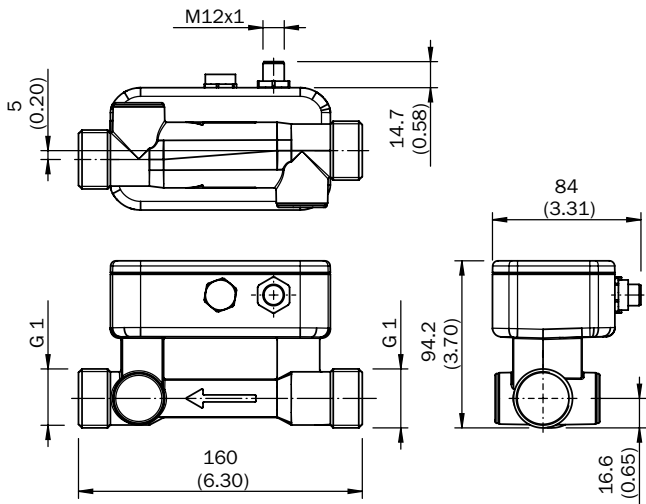

DN 20, 1" NPT

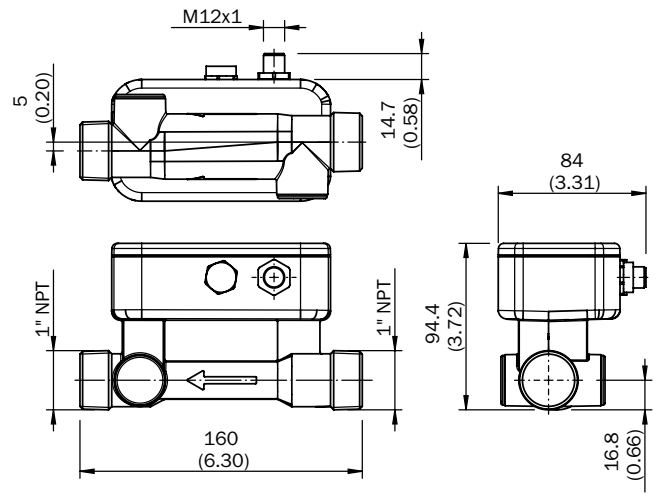

DN 20, Clamp (DIN 11864-3)

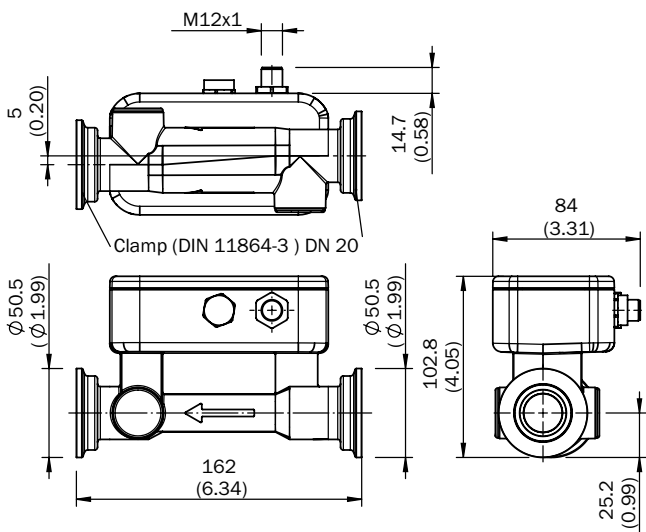

DN 25, G 1 1/4

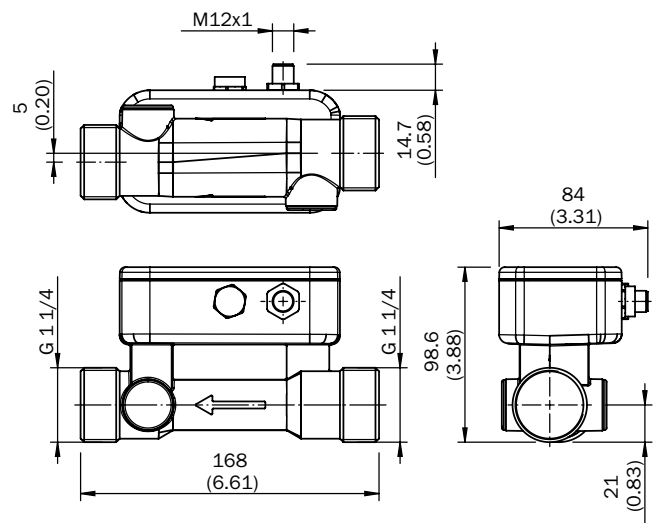

DN 25, 1 1/4" NPT

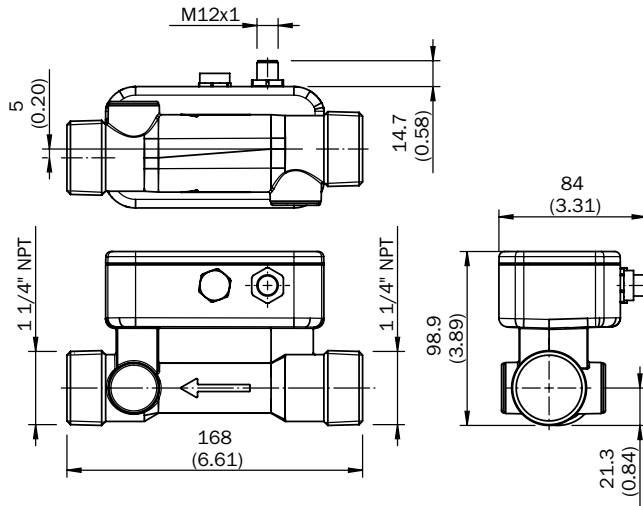

DN 25, Clamp (DIN 11864-3)

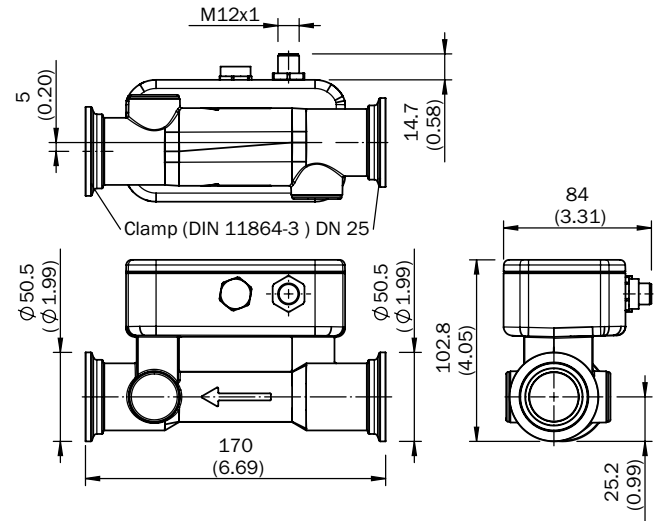

Connection type and diagram

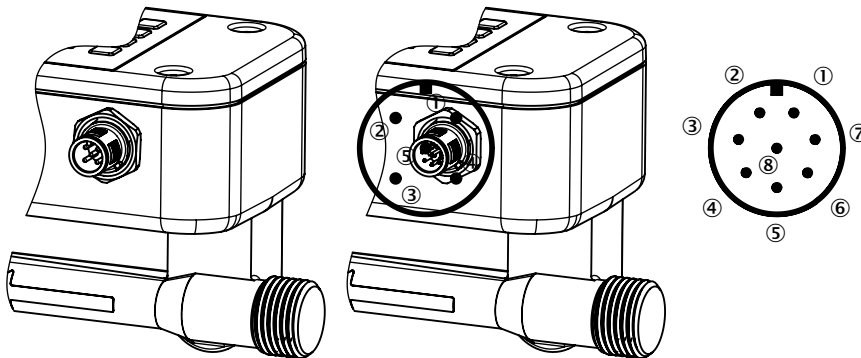

- ① L: Supply voltage
- ② Q₁: Digital output PNP/NPN
- ③ M: Ground
- ④ C: Communication
- ⑤ Q_A: Analog current output

- ① L: Supply voltage
- ② Q₁: Digital output PNP/NPN
- ③ M: Ground
- ④ Q₂: Digital output PNP/NPN
- ⑤ Q_A: Analog current output
- ⑥ C: Communication
- ⑦ IN₁: Digital input
- ⑧ No function

Recommended accessories

- **Connection systems:** Plug connectors and cables
- **Accessory family:** connecting cables with female connector

Brief description	Cable length	Type	Part no.
Head A: female connector, M12, 5-pin, straight Head B: cable Cable: PVC, unshielded	2 m	DOL-1205-G02M	6008899
Head A: female connector, M12, 5-pin, straight Head B: cable Cable: drag chain use, PUR, halogen-free, unshielded	2 m	DOL-1205-G02MC	6025906

Brief description	Cable length	Type	Part no.
Head A: female connector, M12, 5-pin, straight Head B: cable Cable: PVC, unshielded	5 m	DOL-1205-G05M	6009868
Head A: female connector, M12, 5-pin, straight Head B: cable Cable: drag chain use, PUR, halogen-free, unshielded	5 m	DOL-1205-G05MC	6025907
Head A: female connector, M12, 5-pin, straight Head B: cable Cable: PVC, unshielded	10 m	DOL-1205-G10M	6010544
Head A: female connector, M12, 5-pin, straight Head B: cable Cable: drag chain use, PUR, halogen-free, unshielded	10 m	DOL-1205-G10MC	6025908
Head A: female connector, M12, 5-pin, angled Head B: cable Cable: PVC, unshielded	2 m	DOL-1205-W02M	6008900
Head A: female connector, M12, 5-pin, angled Head B: cable Cable: drag chain use, PUR, halogen-free, unshielded	2 m	DOL-1205-W02MC	6025909
Head A: female connector, M12, 5-pin, angled Head B: cable Cable: PVC, unshielded	5 m	DOL-1205-W05M	6009869
Head A: female connector, M12, 5-pin, angled Head B: cable	5 m	DOL-1205-W05MC	6025910
Head A: female connector, M12, 5-pin, angled Head B: cable Cable: drag chain use, PUR, halogen-free, unshielded	10 m	DOL-1205-W10MC	6025911
Head A: female connector, M12, 8-pin, straight Head B: cable	2 m	DOL-1208-G02MF	6020663
Cable: special color code, PVC, shielded	5 m	DOL-1208-G05MF	6020664
	10 m	DOL-1208-G10MF	6048434

Mounting instructions

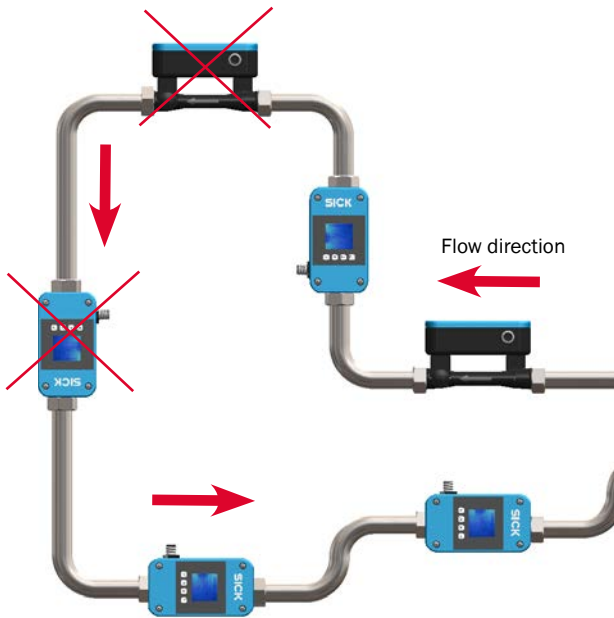

In applications where the flowmeter is exposed to high temperatures ($t \geq 60^\circ\text{C}$), the device should be mounted upside down:

Correct positioning



False positioning



Tube has to be fully filled

Inlet and outlet paths

In order to receive an accurate volume measurement, it is necessary to observe inlet and outlet paths. The diameter of the tube - as given by the process connector of the FFU - should not change directly in front of the device and directly after the device. Minimum inlet and outlet paths are:

Device nominal width	1/2"	3/4"	1"	1 1/4"
Inlet path	10 cm	30 cm	40 cm	40 cm
Outlet path	0 cm	5 cm	10 cm	20 cm

Maximum torque

Always make sure that the maximum torque of the nuts for the hydraulic connections is not overstep. Please use the supplied seals. If you seal with teflon tape that can result in to excessive tightening torques. We commend a maximum torque depending on the diameter of:

	DN 10	DN 15	DN 20	DN 25
Torque G	2 Nm	3 Nm	4 Nm	6 Nm

Attention: The process connections from the FFU are offset by 5 mm (see dimensional drawing on page 6-8).

Mounted FFU must always be mechanically stress free. Strong tension in the pipe system can lead to damage to the devise. Shocks or mechanical loads can affect the measurement accuracy of the measuring device. If the FFU must be additionally secured due to the presence of vibrations or mechanical motion, two mounting clamps can be mounted to the inlet and outlet of the measuring device.

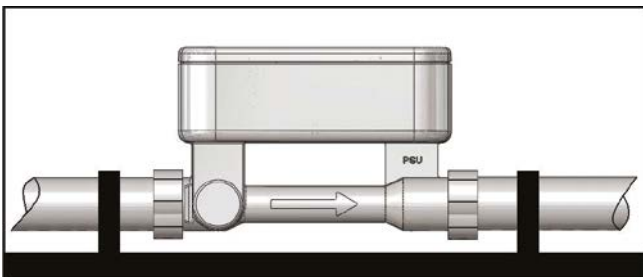

FFU with mounting clamps

REGISTER AT WWW.SICK.COM TODAY AND ENJOY ALL THE BENEFITS



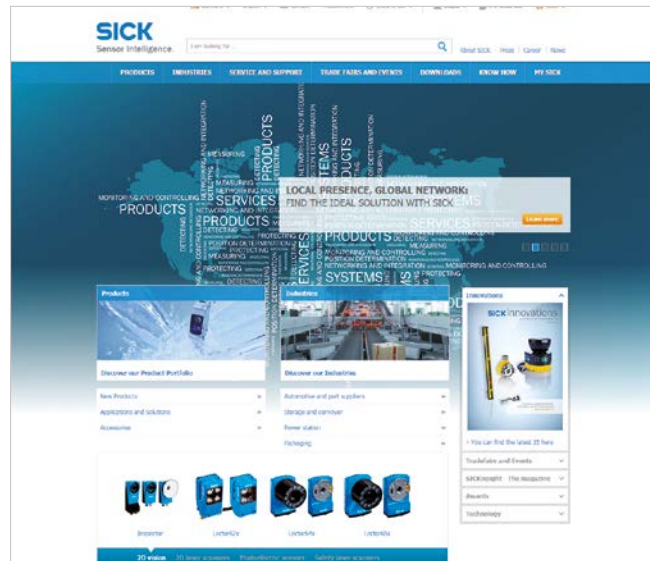

- ✔ Select products, accessories, documentation and software quickly and easily.
- ✔ Create, save and share personalized wish lists.
- ✔ View the net price and date of delivery for every product.
- ✔ Requests for quotation, ordering and delivery tracking made easy.
- ✔ Overview of all quotations and orders.
- ✔ Direct ordering: submit even very complex orders in moments.
- ✔ View the status of quotations and orders at any time. Receive e-mail notifications of status changes.
- ✔ Easily repeat previous orders.
- ✔ Conveniently export quotations and orders to work with your systems.



SERVICES FOR MACHINES AND SYSTEMS: SICK LifeTime Services

Our comprehensive and versatile LifeTime Services are the perfect addition to the comprehensive range of products from SICK. The services range from product-independent consulting to traditional product services.



- 
Consulting and design
 Safe and professional
- 
Product and system support
 Reliable, fast and on-site
- 
Verification and optimization
 Safe and regularly inspected
- 
Upgrade and retrofits
 Easy, safe and economical
- 
Training and education
 Practical, focused and professional

SICK AT A GLANCE

SICK is a leading manufacturer of intelligent sensors and sensor solutions for industrial applications. With more than 7,400 employees and over 50 subsidiaries and equity investments as well as numerous agencies worldwide, we are always close to our customers. A unique range of products and services creates the perfect basis for controlling processes securely and efficiently, protecting individuals from accidents and preventing damage to the environment.

We have extensive experience in various industries and understand their processes and requirements. With intelligent sensors, we can deliver exactly what our customers need. In application centers in Europe, Asia and North America, system solutions are tested and optimized in accordance with customer specifications. All this makes us a reliable supplier and development partner.

Comprehensive services round out our offering: SICK LifeTime Services provide support throughout the machine life cycle and ensure safety and productivity.

For us, that is “Sensor Intelligence.”

Worldwide presence:

Australia, Austria, Belgium, Brazil, Canada, Chile, China, Czech Republic, Denmark, Finland, France, Germany, Great Britain, Hungary, India, Israel, Italy, Japan, Malaysia, Mexico, Netherlands, New Zealand, Norway, Poland, Romania, Russia, Singapore, Slovakia, Slovenia, South Africa, South Korea, Spain, Sweden, Switzerland, Taiwan, Thailand, Turkey, United Arab Emirates, USA, Vietnam.

Detailed addresses and further locations → www.sick.com