



Control User Guide

Unidrive M700

Unidrive M701

Unidrive M702

Universal Variable Speed AC drive for
induction and permanent magnet
motors

Part Number: 0478-0353-02

Issue: 2

Original Instructions

For the purposes of compliance with the EU Machinery Directive 2006/42/EC, the English version of this manual is the Original Instructions. Manuals in other languages are Translations of the Original Instructions.

Documentation

Manuals are available to download from the following locations: <http://www.drive-setup.com/ctdownloads>

The information contained in this manual is believed to be correct at the time of printing and does not form part of any contract. The manufacturer reserves the right to change the specification of the product and its performance, and the contents of the manual, without notice.

Warranty and Liability

In no event and under no circumstances shall the manufacturer be liable for damages and failures due to misuse, abuse, improper installation, or abnormal conditions of temperature, dust, or corrosion, or failures due to operation outside the published ratings. The manufacturer is not liable for consequential and incidental damages. Contact the supplier of the dive for full details of the warranty terms.

Environmental policy

Control Techniques Ltd operates an Environmental Management System (EMS) that conforms to the International Standard ISO 14001.

Further information on our Environmental Policy can be found at: <http://www.drive-setup.com/environment>

Restriction of Hazardous Substances (RoHS)

The products covered by this manual comply with European and International regulations on the Restriction of Hazardous Substances including EU directive 2011/65/EU and the Chinese Administrative Measures for Restriction of Hazardous Substances in Electrical and Electronic Products.

Disposal and Recycling (WEEE)

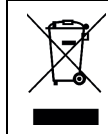

When electronic products reach the end of their useful life, they must not be disposed of along with domestic waste but should be recycled by a specialist recycler of electronic equipment. Control Techniques products are designed to be easily dismantled into their major component parts for efficient recycling. The majority of materials used in the product are suitable for recycling.

Product packaging is of good quality and can be re-used. Large products are packed in wooden crates. Smaller products are packaged in strong cardboard cartons which have a high recycled fibre content. Cartons can be re-used and recycled. Polythene, used in protective film and bags for wrapping the product, can be recycled. When preparing to recycle or dispose of any product or packaging, please observe local legislation and best practice.

REACH legislation

EC Regulation 1907/2006 on the Registration, Evaluation, Authorisation and restriction of Chemicals (REACH) requires the supplier of an article to inform the recipient if it contains more than a specified proportion of any substance which is considered by the European Chemicals Agency (ECHA) to be a Substance of Very High Concern (SVHC) and is therefore listed by them as a candidate for compulsory authorisation.

Further information on our compliance with REACH can be found at: <http://www.drive-setup.com/reach>

Registered Office

Nidec Control Techniques Ltd

The Gro

Newtown

Powys

SY16 3BE

UK

Registered in England and Wales. Company Reg. No. 01236886.

Copyright

The contents of this publication are believed to be correct at the time of printing. In the interests of a commitment to a policy of continuous development and improvement, the manufacturer reserves the right to change the specification of the product or its performance, or the contents of the guide, without notice.

All rights reserved. No parts of this guide may be reproduced or transmitted in any form or by any means, electrical or mechanical including photocopying, recording or by an information storage or retrieval system, without permission in writing from the publisher.

Copyright © January 2018 Nidec Control Techniques Ltd

Drive Firmware: 01.17.00.00 onwards

Ethernet Firmware: 02.02.02.00 onwards

For patent and intellectual property related information please go to: www.ctpatents.info.

How to use this guide

This guide is intended to be used in conjunction with the appropriate *Power Installation Guide*. The *Power Installation Guide* gives information necessary to physically install the drive. This guide gives information on drive configuration, operation and optimization.

NOTE

There are specific safety warnings throughout this guide, located in the relevant sections. In addition, Chapter 1 *Safety information* contains general safety information. It is essential that the warnings are observed and the information considered when working with or designing a system using the drive.

This map of the user guide helps to find the right sections for the task you wish to complete, but for specific information, refer to *Contents* on page 4:

	Quick Start / bench testing	Familiarisation	System design	Programming and commissioning	Troubleshooting
1 Safety information	●	●	●	●	●
2 Product information		●	●		
3 Mechanical installation			●		
4 Electrical installation			●		
5 Getting started		●	●		
6 Basic parameters		●	●	●	
7 Running the motor	●	●	●	●	
8 Optimization			●	●	
9 Communication			●	●	
10 NV media card operation			●	●	
11 Onboard PLC			●	●	
12 Advanced parameters			●	●	
13 Diagnostics					●
14 UL listing information			●	●	

Contents

1	Safety information	9	6	Basic parameters	49
1.1	Warnings, Cautions and Notes	9	6.1	Parameter ranges and variable minimum / maximums	49
1.2	Important safety information. Hazards. Competence of designers and installers	9	6.2	Menu 0: Basic parameters	49
1.3	Responsibility	9	6.3	Parameter descriptions	56
1.4	Compliance with regulations	9	6.4	Full descriptions	58
1.5	Electrical hazards	9	7	Running the motor	69
1.6	Stored electrical charge	9	7.1	Quick start connections	69
1.7	Mechanical hazards	9	7.2	Changing the operating mode	69
1.8	Access to equipment	9	7.3	Quick start commissioning / start-up	78
1.9	Environmental limits	9	7.4	Setting up a feedback device	84
1.10	Hazardous environments	9	7.5	Encoder Simulation Output Set-up	92
1.11	Motor	10	8	Optimization	95
1.12	Mechanical brake control	10	8.1	Motor map parameters	95
1.13	Adjusting parameters	10	8.2	Maximum motor rated current	108
1.14	Electromagnetic compatibility (EMC)	10	8.3	Current limits	108
2	Product information	11	8.4	Motor thermal protection	108
2.1	Introduction	11	8.5	Switching frequency	109
2.2	Model number	11	8.6	High speed operation	109
2.3	Ratings	12	9	Drive communication	111
2.4	Operating modes	13	9.1	CT Modbus RTU specification (Unidrive M701)	111
2.5	Compatible position feedback devices	14	9.2	Ethernet communication (Unidrive M700 / M702)	115
2.6	Nameplate description	15	9.3	CT Modbus TCP/IP specification (Unidrive M700 / M702)	116
2.7	Options	16	9.4	RTMoE (Real Time Motion over Ethernet) (Unidrive M700 / M702)	121
3	Mechanical installation	19	9.5	EtherNet/IP specification (Unidrive M700 / M702)	123
3.1	Installing / removing option modules and keypads	19	9.6	Profinet IO specification (Unidrive M700 / M702)	135
3.2	Real time clock battery replacement	21	10	NV Media Card Operation	139
4	Electrical installation	22	10.1	Introduction	139
4.1	24 Vdc supply	22	10.2	NV Media Card support	139
4.2	Communication connections	23	10.3	Transferring data	140
4.3	Control connections	24	10.4	Data block header information	141
4.4	Position feedback connections	31	10.5	NV Media Card parameters	141
4.5	Safe Torque Off (STO)	37	10.6	NV Media Card trips	142
5	Getting started	40	11	Onboard PLC	143
5.1	Understanding the display	40	11.1	Onboard PLC and Machine Control Studio	143
5.2	Keypad operation	40	11.2	Benefits	143
5.3	Menu structure	42	11.3	Features	143
5.4	Menu 0	43	11.4	Onboard PLC parameters	144
5.5	Advanced menus	43	11.5	Onboard PLC trips	144
5.6	Changing the operating mode	45			
5.7	Saving parameters	45			
5.8	Restoring parameter defaults	45			
5.9	Parameter access level and security	46			
5.10	Displaying parameters with non-default values only	46			
5.11	Displaying destination parameters only	46			
5.12	Communications	46			

12	Advanced parameters	145	13	Diagnostics	245
12.1	Parameter ranges and Variable minimum/ maximums	148	13.1	Status modes (Keypad and LED status)	245
12.2	Menu 1: Frequency / speed reference	158	13.2	Trip indications	245
12.3	Menu 2: Ramps	162	13.3	Identifying a trip / trip source	246
12.4	Menu 3: Frequency slaving, speed feedback and speed control	165	13.4	Trips, Sub-trip numbers	247
12.5	Menu 4: Torque and current control	176	13.5	Internal / Hardware trips	278
12.6	Menu 5: Motor control	180	13.6	Alarm indications	279
12.7	Menu 6: Sequencer and clock	187	13.7	Status indications	279
12.8	Menu 7: Analog I/O / Temperature Monitoring ..	191	13.8	Programming error indications	279
12.9	Menu 8: Digital I/O	196	13.9	Displaying the trip history	280
12.10	Menu 9: Programmable logic, motorized pot, binary sum and timers	202	13.10	Behaviour of the drive when tripped	280
12.11	Menu 10: Status and trips	208	14	UL information	281
12.12	Menu 11: General drive set-up	210	14.1	UL file reference	281
12.13	Menu 12: Threshold detectors, variable selectors and brake control function	212	14.2	Option modules, kits and accessories	281
12.14	Menu 13: Standard motion controller	220	14.3	Enclosure ratings	281
12.15	Menu 14: User PID controller	224	14.4	Mounting	281
12.16	Menus 15, 16 and 17: Option module set-up ..	228	14.5	Environment	281
12.17	Menu 18: Application menu 1	229	14.6	Electrical Installation	281
12.18	Menu 19: Application menu 2	229	14.7	Motor overload protection and thermal memory retention	282
12.19	Menu 20: Application menu 3	229	14.8	External Class 2 supply	282
12.20	Menu 21: Second motor parameters	230	14.9	Modular Drive Systems	282
12.21	Menu 22: Additional Menu 0 set-up	232	14.10	Requirement for Transient Surge Suppression ..	282
12.22	Menu 24: Ethernet interface information (Unidrive M700 / M702)	233			
12.23	Slot 4 Menus (Unidrive M700 / M702)	234			
12.24	Slot 4 Menu 0: Ethernet interface information (Unidrive M700 / M702)	234			
12.25	Slot 4 Menu 2: Ethernet configuration (Unidrive M700 / M702)	235			
12.26	Slot 4 Menu 9: Resources (Unidrive M700 / M702)	235			
12.27	Slot 4 Menu 10: RTMoE Easy Mode Cyclic Data (Unidrive M700 / M702)	236			
12.28	Slot 4 Menu 11: Synchronization (Unidrive M700 / M702)	238			
12.29	Slot 4 Menu 15: Modbus TCP/IP Set-up (Unidrive M700 / M702)	239			
12.30	Slot 4 Menu 20: EtherNet/IP Set-up (Unidrive M700 / M702)	240			
12.31	Slot 4 Menu 21: EtherNet/IP In Mappings (Unidrive M700 / M702)	241			
12.32	Slot 4 Menu 22: EtherNet/IP Out Mappings (Unidrive M700 / M702)	242			
12.33	Slot 4 Menu 23: EtherNet/IP Fault Values (Unidrive M700 / M702)	243			
12.34	Slot 4 Menu 24: Profinet Set-up (Unidrive M700 / M702)	244			

EU Declaration of Conformity

Nidec Control Techniques Ltd

The Gro

Newtown

Powys

SY16 3BE

UK

This declaration is issued under the sole responsibility of the manufacturer. The object of the declaration is in conformity with the relevant European Union harmonization legislation. The declaration applies to the variable speed drive products shown below:

Model number	Interpretation	Nomenclature aaaa - bbc ddddde
aaaa	Basic series	M100, M101, M200, M201, M300, M400, M600, M700, M701, M702, M708, M709, M751, M753, M754, F300, H300, E200, E300, HS30, HS70, HS71, HS72, M000, RECT
bb	Frame size	01, 02, 03, 04, 05, 06, 07, 08, 09, 10, 11
c	Voltage rating	1 = 100 V, 2 = 200 V, 4 = 400 V, 5 = 575 V, 6 = 690 V
dddd	Current rating	Example 01000 = 100 A
e	Drive format	A = 6P Rectifier + Inverter (internal choke), D = Inverter, E = 6P Rectifier + Inverter (external choke), T = 12P Rectifier + Inverter (external choke)

The model number may be followed by additional characters that do not affect the ratings.

The variable speed drive products listed above have been designed and manufactured in accordance with the following European harmonized standards:

EN 61800-5-1:2007	Adjustable speed electrical power drive systems - Part 5-1: Safety requirements - Electrical, thermal and energy
EN 61800-3: 2004+A1:2012	Adjustable speed electrical power drive systems - Part 3: EMC requirements and specific test methods
EN 61000-6-2:2005	Electromagnetic compatibility (EMC) - Part 6-2: Generic standards - Immunity for industrial environments
EN 61000-6-4: 2007+ A1:2011	Electromagnetic compatibility (EMC) - Part 6-4: Generic standards - Emission standard for industrial environments
EN 61000-3-2:2014	Electromagnetic compatibility (EMC) - Part 3-2: Limits for harmonic current emissions (equipment input current ≤ 16 A per phase)
EN 61000-3-3:2013	Electromagnetic compatibility (EMC) - Part 3-3: Limitation of voltage changes, voltage fluctuations and flicker in public, low voltage supply systems, for equipment with rated current ≤ 16 A per phase and not subject to conditional connection

EN 61000-3-2:2014 Applicable where input current < 16 A. No limits apply for professional equipment where input power ≥ 1 kW.

These products comply with the Restriction of Hazardous Substances Directive (2011/65/EU), the Low Voltage Directive (2014/35/EU) and the Electromagnetic Compatibility Directive (2014/30/EU).



G Williams

Vice President, Technology

Date: 6th September 2017

These electronic drive products are intended to be used with appropriate motors, controllers, electrical protection components and other equipment to form complete end products or systems. Compliance with safety and EMC regulations depends upon installing and configuring drives correctly, including using the specified input filters.

The drives must be installed only by professional installers who are familiar with requirements for safety and EMC. Refer to the Product Documentation. An EMC data sheet is available giving detailed information. The assembler is responsible for ensuring that the end product or system complies with all the relevant laws in the country where it is to be used.

EU Declaration of Conformity (including 2006 Machinery Directive)

Nidec Control Techniques Ltd
The Gro
Newtown
Powys
SY16 3BE
UK

This declaration is issued under the sole responsibility of the manufacturer. The object of the declaration is in conformity with the relevant Union harmonization legislation. The declaration applies to the variable speed drive products shown below:

Model No.	Interpretation	Nomenclature aaaa - bbc ddddde
aaaa	Basic series	M600, M700, M701, M702, M708, M709, M751, M753, M754, F300, H300, E200, E300, HS70, HS71, HS72, M000, RECT
bb	Frame size	01, 02, 03, 04, 05, 06, 07, 08, 09, 10, 11
c	Voltage rating	1 = 100 V, 2 = 200 V, 4 = 400 V, 5 = 575 V, 6 = 690 V
dddd	Current rating	Example 01000 = 100 A
e	Drive format	A = 6P Rectifier + Inverter (internal choke), D = Inverter, E = 6P Rectifier + Inverter (external choke), T = 12P Rectifier + Inverter (external choke)

The model number may be followed by additional characters that do not affect the ratings.

This declaration relates to these products when used as a safety component of a machine. Only the Safe Torque Off function may be used for a safety function of a machine. None of the other functions of the drive may be used to carry out a safety function.

These products fulfil all the relevant provisions of the Machinery Directive 2006/42/EC and the Electromagnetic Compatibility Directive (2014/30/EU).

EC type examination has been carried out by the following notified body:

TUV Rheinland Industrie Service GmbH
 Am Grauen Stein
 D-51105 Köln
 Germany

The harmonized standards used are shown below:

EC type-examination certificate numbers:

01/205/5270.02/17 dated 2017-08-28

Notified body identification number: 0035

EN 61800-5-1:2016	Adjustable speed electrical power drive systems - Part 5-2: Safety requirements - Functional
EN 61800-5-1:2016 (in extracts)	Adjustable speed electrical power drive systems - Part 5-1: Safety requirements - Electrical, thermal and energy
EN 61800-3: 2004+A1:2012	Adjustable speed electrical power drive systems - Part 3: EMC requirements and specific test methods
EN ISO 13849-1:2015	Safety of Machinery, Safety-related parts of control systems, General principles for design
EN 62061:2005 + AC:2010 + A1:2013 + A2:2015	Safety of machinery, Functional safety of safety related electrical, electronic and programmable electronic control systems
IEC 61508 Parts 1 - 7:2010	Functional safety of electrical/ electronic/programmable electronic safety-related systems

Person authorised to complete the technical file:

P Knight
 Conformity Engineer
 Newtown, Powys, UK

DoC authorised by:



G. Williams

Vice President, Technology

Date: 6th September 2017

Place: Newtown, Powys, UK

IMPORTANT NOTICE

These electronic drive products are intended to be used with appropriate motors, controllers, electrical protection components and other equipment to form complete end products or systems. It is the responsibility of the installer to ensure that the design of the complete machine, including its safety-related control system, is carried out in accordance with the requirements of the Machinery Directive and any other relevant legislation. The use of a safety-related drive in itself does not ensure the safety of the machine. Compliance with safety and EMC regulations depends upon installing and configuring drives correctly, including using the specified input filters. The drive must be installed only by professional installers who are familiar with requirements for safety and EMC. The assembler is responsible for ensuring that the end product or system complies with all relevant laws in the country where it is to be used. For more information regarding Safe Torque Off, refer to the Product Documentation.

Safety information	Product information	Mechanical installation	Electrical installation	Getting started	Basic parameters	Running the motor	Optimization	Drive communication	NV Media Card Operation	Onboard PLC	Advanced parameters	Diagnostics	UL information
--------------------	---------------------	-------------------------	-------------------------	-----------------	------------------	-------------------	--------------	---------------------	-------------------------	-------------	---------------------	-------------	----------------

1 Safety information

1.1 Warnings, Cautions and Notes



A Warning contains information which is essential for avoiding a safety hazard.



A Caution contains information which is necessary for avoiding a risk of damage to the product or other equipment.

NOTE

A Note contains information which helps to ensure correct operation of the product.

1.2 Important safety information. Hazards. Competence of designers and installers

This guide applies to products which control electric motors either directly (drives) or indirectly (controllers, option modules and other auxiliary equipment and accessories). In all cases the hazards associated with powerful electrical drives are present, and all safety information relating to drives and associated equipment must be observed.

Specific warnings are given at the relevant places in this guide.

Drives and controllers are intended as components for professional incorporation into complete systems. If installed incorrectly they may present a safety hazard. The drive uses high voltages and currents, carries a high level of stored electrical energy, and is used to control equipment which can cause injury. Close attention is required to the electrical installation and the system design to avoid hazards either in normal operation or in the event of equipment malfunction. System design, installation, commissioning/start-up and maintenance must be carried out by personnel who have the necessary training and competence. They must read this safety information and this guide carefully.

1.3 Responsibility

It is the responsibility of the installer to ensure that the equipment is installed correctly with regard to all instructions given in this guide. They must give due consideration to the safety of the complete system, so as to avoid the risk of injury both in normal operation and in the event of a fault or of reasonably foreseeable misuse.

The manufacturer accepts no liability for any consequences resulting from inappropriate, negligent or incorrect installation of the equipment.

1.4 Compliance with regulations

The installer is responsible for complying with all relevant regulations, such as national wiring regulations, accident prevention regulations and electromagnetic compatibility (EMC) regulations. Particular attention must be given to the cross-sectional areas of conductors, the selection of fuses or other protection, and protective ground (earth) connections.

This guide contains instructions for achieving compliance with specific EMC standards.

All machinery to be supplied within the European Union in which this product is used must comply with the following directives:

2006/42/EC Safety of machinery.

2014/30/EU: Electromagnetic Compatibility.

1.5 Electrical hazards

The voltages used in the drive can cause severe electrical shock and/or burns, and could be lethal. Extreme care is necessary at all times when working with or adjacent to the drive. Hazardous voltage may be present in any of the following locations:

- AC and DC supply cables and connections
- Output cables and connections
- Many internal parts of the drive, and external option units

Unless otherwise indicated, control terminals are single insulated and must not be touched.

The supply must be disconnected by an approved electrical isolation device before gaining access to the electrical connections.

The STOP and Safe Torque Off functions of the drive do not isolate dangerous voltages from the output of the drive or from any external option unit.

The drive must be installed in accordance with the instructions given in this guide. Failure to observe the instructions could result in a fire hazard.

1.6 Stored electrical charge

The drive contains capacitors that remain charged to a potentially lethal voltage after the AC supply has been disconnected. If the drive has been energized, the AC supply must be isolated at least ten minutes before work may continue.

1.7 Mechanical hazards

Careful consideration must be given to the functions of the drive or controller which might result in a hazard, either through their intended behaviour or through incorrect operation due to a fault. In any application where a malfunction of the drive or its control system could lead to or allow damage, loss or injury, a risk analysis must be carried out, and where necessary, further measures taken to reduce the risk - for example, an over-speed protection device in case of failure of the speed control, or a fail-safe mechanical brake in case of loss of motor braking.

With the sole exception of the Safe Torque Off function, none of the drive functions must be used to ensure safety of personnel, i.e. they must not be used for safety-related functions.

The Safe Torque Off function may be used in a safety-related application. The system designer is responsible for ensuring that the complete system is safe and designed correctly according to the relevant safety standards.

The design of safety-related control systems must only be done by personnel with the required training and experience. The Safe Torque Off function will only ensure the safety of a machine if it is correctly incorporated into a complete safety system. The system must be subject to a risk assessment to confirm that the residual risk of an unsafe event is at an acceptable level for the application.

1.8 Access to equipment

Access must be restricted to authorized personnel only. Safety regulations which apply at the place of use must be complied with.

1.9 Environmental limits

Instructions in this guide regarding transport, storage, installation and use of the equipment must be complied with, including the specified environmental limits. This includes temperature, humidity, contamination, shock and vibration. Drives must not be subjected to excessive physical force.

1.10 Hazardous environments

The equipment must not be installed in a hazardous environment (i.e. a potentially explosive environment).

Safety information	Product information	Mechanical installation	Electrical installation	Getting started	Basic parameters	Running the motor	Optimization	Drive communication	NV Media Card Operation	Onboard PLC	Advanced parameters	Diagnostics	UL information
--------------------	---------------------	-------------------------	-------------------------	-----------------	------------------	-------------------	--------------	---------------------	-------------------------	-------------	---------------------	-------------	----------------

1.11 Motor

The safety of the motor under variable speed conditions must be ensured.

To avoid the risk of physical injury, do not exceed the maximum specified speed of the motor.

Low speeds may cause the motor to overheat because the cooling fan becomes less effective, causing a fire hazard. The motor should be installed with a protection thermistor. If necessary, an electric forced vent fan should be used.

The values of the motor parameters set in the drive affect the protection of the motor. The default values in the drive must not be relied upon. It is essential that the correct value is entered in the Motor Rated Current parameter.

1.12 Mechanical brake control

Any brake control functions are provided to allow well co-ordinated operation of an external brake with the drive. While both hardware and software are designed to high standards of quality and robustness, they are not intended for use as safety functions, i.e. where a fault or failure would result in a risk of injury. In any application where the incorrect operation of the brake release mechanism could result in injury, independent protection devices of proven integrity must also be incorporated.

1.13 Adjusting parameters

Some parameters have a profound effect on the operation of the drive. They must not be altered without careful consideration of the impact on the controlled system. Measures must be taken to prevent unwanted changes due to error or tampering.

1.14 Electromagnetic compatibility (EMC)

Installation instructions for a range of EMC environments are provided in the relevant Power Installation Guide. If the installation is poorly designed or other equipment does not comply with suitable standards for EMC, the product might cause or suffer from disturbance due to electromagnetic interaction with other equipment. It is the responsibility of the installer to ensure that the equipment or system into which the product is incorporated complies with the relevant EMC legislation in the place of use.

2 Product information

2.1 Introduction

Universal AC and servo drive

This product family consists of *Unidrive M700*, *Unidrive M701* and *Unidrive M702*, these deliver maximum machine performance.

Common features (Unidrive M700, 701 and 702)

- Universal high performance open and closed loop control for induction, servo, permanent magnet and linear motors
- Automation and motion option module for direct migration of SyPTPro / SM-Applications programs
- Onboard IEC 61131-3 programmable automation and motion control
- Flexibility with speed and position measurement, supporting multiple devices and all common interfaces
- NV Media Card for parameter copying and data storage

Optional features (Unidrive M700, 701 and 702)

- Select up to three option modules including programmable automation and motion control.

Unidrive M700

- Ethernet fieldbus communications
- Single channel Safe Torque Off (STO) input

Unidrive M701

- Provides a direct replacement / upgrade for Unidrive SP
- EIA 485 serial communications interface
- Single channel Safe Torque Off (STO) input

Unidrive M702

- Ethernet fieldbus communications
- Dual channel Safe Torque Off (STO) input

2.2 Model number

The way in which the model numbers for the *Unidrive M700* range are formed is illustrated below:

Figure 2-1 Model number

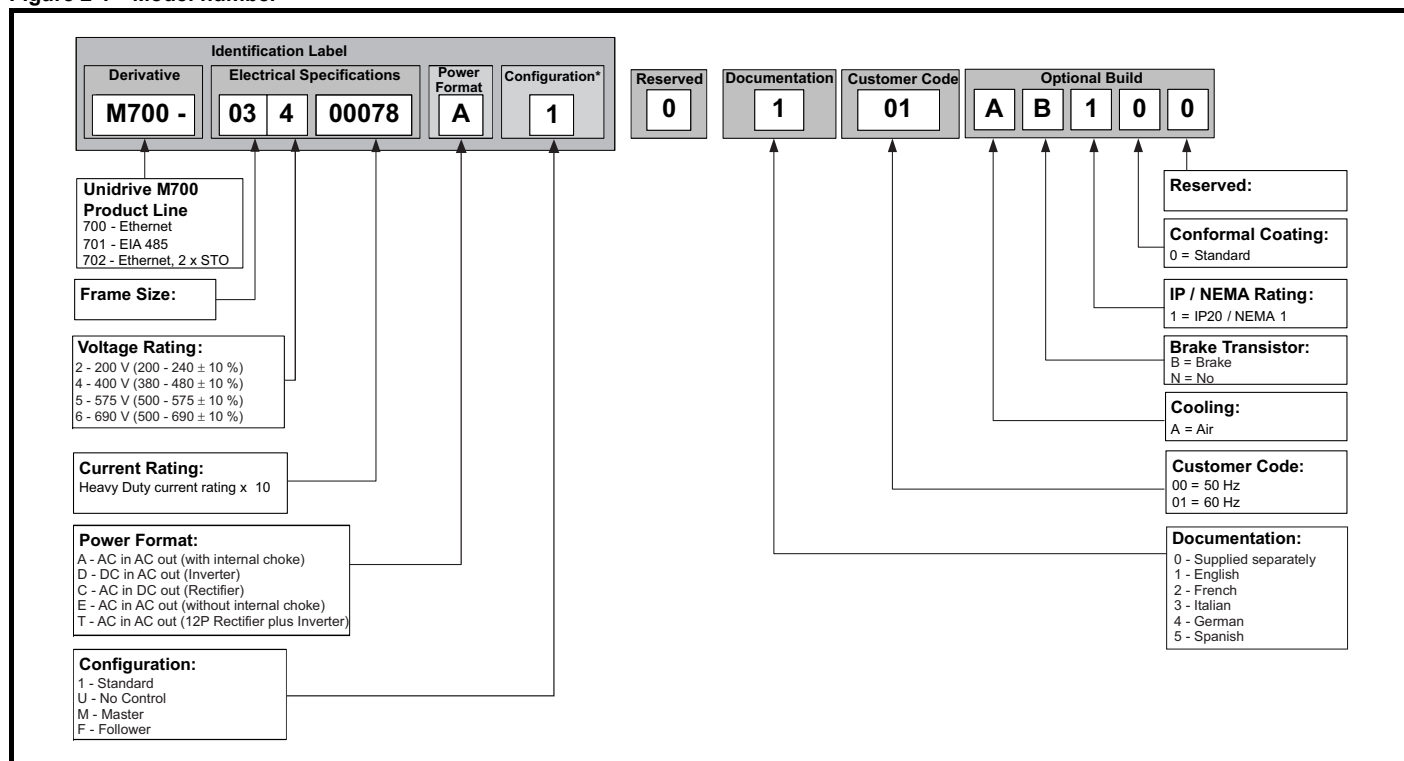

* Only shown on Frame size 9, 10 and 11 identification label.

NOTE

For simplicity a Frame 9 drive with no internal choke (i.e. model 09xxxxxE) is referred to as a Frame 9E and a Frame 9 drive with an internal choke (i.e. model 09xxxxxA) is referred to as a Frame 9A. Any reference to Frame 9 is applicable to both sizes 9E and 9A.

2.3 Ratings

The drive is dual rated.
 The setting of the motor rated current determines which rating applies - Heavy Duty or Normal Duty.
 The two ratings are compatible with motors designed to IEC60034.
 The graph aside illustrates the difference between Normal Duty and Heavy Duty with respect to continuous current rating and short term overload limits.

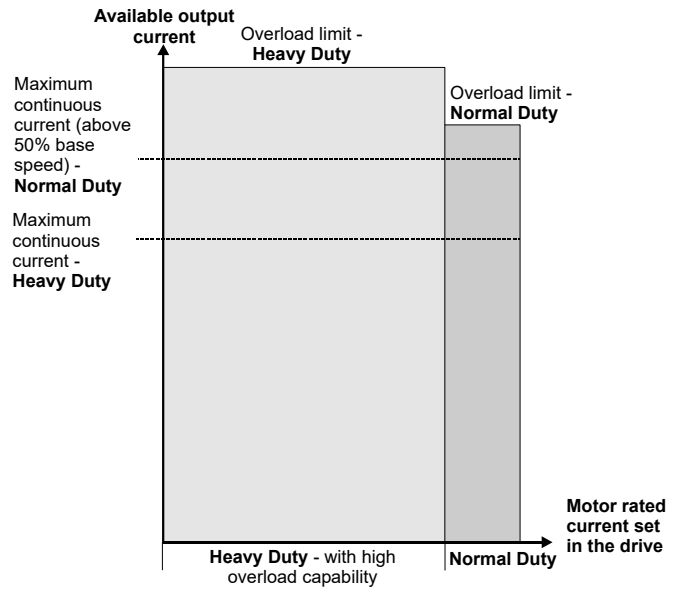

Normal Duty	Heavy Duty (default)
<p>For applications which use Self ventilated (TENV/TEFC) induction motors and require a low overload capability, and full torque at low speeds is not required (e.g. fans, pumps). Self ventilated (TENV/TEFC) induction motors require increased protection against overload due to the reduced cooling effect of the fan at low speed. To provide the correct level of protection the I^2t software operates at a level which is speed dependent. This is illustrated in the graph below.</p> <p>NOTE</p> <p>The speed at which the low speed protection takes effect can be changed by the setting of <i>Low Speed Thermal Protection Mode</i> (04.025). The protection starts when the motor speed is below 15 % of base speed when Pr 04.025 = 0 (default) and below 50 % when Pr 04.025 = 1.</p>	<p>For constant torque applications or applications which require a high overload capability, or full torque is required at low speeds (e.g. winders, hoists). The thermal protection is set to protect force ventilated induction motors and permanent magnet servo motors by default.</p> <p>NOTE</p> <p>If the application uses a self ventilated (TENV/TEFC) induction motor and increased thermal protection is required for speeds below 50 % base speed, then this can be enabled by setting <i>Low Speed Thermal Protection Mode</i> (04.025) = 1.</p>

Operation of motor I^2t protection	
<p>Motor I^2t protection is fixed as shown below and is compatible with:</p> <ul style="list-style-type: none"> Self ventilated (TENV/TEFC) induction motors 	<p>Motor I^2t protection defaults to be compatible with:</p> <ul style="list-style-type: none"> Forced ventilation induction motors Permanent magnet servo motors

Safety information	Product information	Mechanical installation	Electrical installation	Getting started	Basic parameters	Running the motor	Optimization	Drive communication	NV Media Card Operation	Onboard PLC	Advanced parameters	Diagnostics	UL information
--------------------	---------------------	-------------------------	-------------------------	-----------------	------------------	-------------------	--------------	---------------------	-------------------------	-------------	---------------------	-------------	----------------

2.4 Operating modes

The drive is designed to operate in any of the following modes:

1. Open loop mode
 - Open loop vector mode
 - Fixed V/F mode (V/Hz)
 - Quadratic V/F mode (V/Hz)
2. RFC - A
 - With position feedback sensor
 - Without position feedback sensor (Sensorless)
3. RFC - S
 - With position feedback sensor
 - Without position feedback sensor (Sensorless)
4. Regen mode

2.4.1 Open loop mode

The drive applies power to the motor at frequencies varied by the user. The motor speed is a result of the output frequency of the drive and slip due to the mechanical load. The drive can improve the speed control of the motor by applying slip compensation. The performance at low speed depends on whether V/F mode or open loop vector mode is selected.

Open loop vector mode

The voltage applied to the motor is directly proportional to the frequency except at low speed where the drive uses motor parameters to apply the correct voltage to keep the flux constant under varying load conditions.

Typically 100 % torque is available down to 1 Hz for a 50 Hz motor.

Fixed V/F mode

The voltage applied to the motor is directly proportional to the frequency except at low speed where a voltage boost is provided which is set by the user. This mode can be used for multi-motor applications.

Typically 100 % torque is available down to 4 Hz for a 50 Hz motor.

Quadratic V/F mode

The voltage applied to the motor is directly proportional to the square of the frequency except at low speed where a voltage boost is provided which is set by the user. This mode can be used for running fan or pump applications with quadratic load characteristics or for multi-motor applications. This mode is not suitable for applications requiring a high starting torque.

2.4.2 RFC-A mode

Rotor Flux Control for Asynchronous (induction) motors (**RFC-A**) encompasses closed loop vector control with a position feedback device

With position feedback

For use with induction motors with a feedback device installed. The drive directly controls the speed of the motor using the feedback device to ensure the rotor speed exactly as demanded. Motor flux is accurately controlled at all times to provide full torque all the way down to zero speed.

Without position feedback (Sensorless)

Sensorless mode provides closed loop control without the need for position feedback by using current, voltages and key motor parameters to estimate the motor speed. It can eliminate instability traditionally associated with open loop control such as operating large motors with light loads at low frequencies.

2.4.3 RFC- S mode

Rotor Flux Control for Synchronous (permanent magnet brushless) motors (**RFC-S**) provides closed loop control with position feedback device.

With position feedback

For use with permanent magnet brushless motors with a feedback device installed.

The drive directly controls the speed of the motor using the feedback device to ensure the rotor speed is exactly as demanded. Flux control is not required because the motor is self excited by the permanent magnets which form part of the rotor.

Absolute position information is required from the feedback device to ensure the output voltage is accurately matched to the back EMF of the motor. Full torque is available all the way down to zero speed.

Without position feedback

For use with permanent magnet brushless motors without a feedback device installed.

Flux control is not required because the motor is self excited by the permanent magnets which form part of the rotor.

Full torque is available all the way down to zero speed, with salient motors.

2.4.4 Regen mode

For use as a regenerative front end for four quadrant operation.

Regen operation allows bi-directional power flow to and from the AC supply. This provides far greater efficiency levels in applications which would otherwise dissipate large amounts of energy in the form of heat in a braking resistor.

The harmonic content of the input current is negligible due to the sinusoidal nature of the waveform when compared to a conventional bridge rectifier or SCR/thyristor front end.

NOTE

Contact the supplier of the drive for further information.

Safety information	Product information	Mechanical installation	Electrical installation	Getting started	Basic parameters	Running the motor	Optimization	Drive communication	NV Media Card Operation	Onboard PLC	Advanced parameters	Diagnostics	UL information
--------------------	---------------------	-------------------------	-------------------------	-----------------	------------------	-------------------	--------------	---------------------	-------------------------	-------------	---------------------	-------------	----------------

2.5 Compatible position feedback devices

Table 2-1 Supported feedback devices

Encoder type	Pr 3.038 setting
Quadrature incremental encoders with or without marker pulse	AB (0)
Quadrature incremental encoders with UVW commutation signals for absolute position for permanent magnet motors with or without marker pulse	AB Servo (3)
Forward / reverse incremental encoders with or without marker pulse	FR (2)
Forward / reverse incremental encoders with UVW commutation signals for absolute position for permanent magnet motors with or without marker pulse	FR Servo (5)
Frequency and direction incremental encoders with or without marker pulse	FD (1)
Frequency and direction incremental encoders with UVW commutation signals for absolute position for permanent magnet motors with or without marker pulse	FD Servo (4)
Sincos incremental encoders	SC (6)
Sincos incremental with commutation signals	SC Servo (12)
Heidenhain sincos encoders with EnDat comms for absolute position	SC EnDat (9)
Stegmann sincos encoders with Hiperface comms for absolute position	SC Hiperface (7)
Sincos encoders with SSI comms for absolute position	SC SSI (11)
Sincos encoders with BiSS (type C) comms for absolute position	SC BiSS (17)
Sincos incremental with absolute position from single sin and cosine signals	SC SC (15)
SSI encoders (Gray code or binary)	SSI (10)
EnDat communication only encoders	EnDat (8)
BiSS (type C) communication only encoders	BiSS (13)
Resolver	Resolver (14)
UVW commutation only encoders*	Commutation only (16)
Provided by option module	Option Slot 1 (18) Option Slot 2 (19) Option Slot 3 (20) Option Slot 4 (21)

* This feedback device provides very low resolution feedback and should not be used for applications requiring a high level of performance.

2.6 Nameplate description

Figure 2-2 Typical drive rating labels

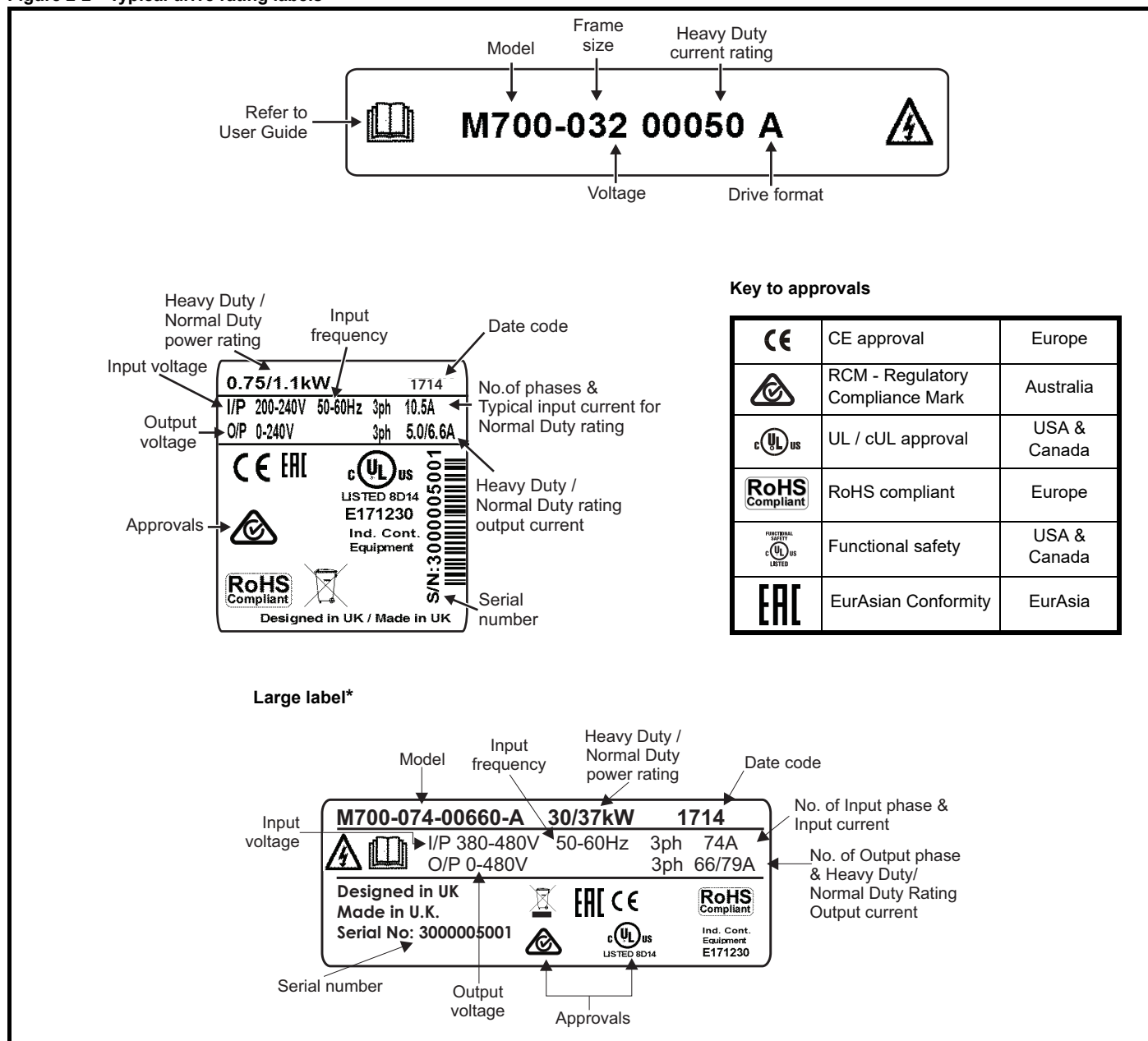

* This label is only applicable to Size 7 and above.

Refer to Figure 2-1 *Model number* on page 11 for further information relating to the labels.

Date code format

The date code consists of four numbers, the first two numbers indicate the year and the remaining two numbers indicate the week of the year in which the drive was built.

Example:

A date code of 1714 would correspond to week 14 of the year 2017.

Safety information	Product information	Mechanical installation	Electrical installation	Getting started	Basic parameters	Running the motor	Optimization	Drive communication	NV Media Card Operation	Onboard PLC	Advanced parameters	Diagnostics	UL information
--------------------	---------------------	-------------------------	-------------------------	-----------------	------------------	-------------------	--------------	---------------------	-------------------------	-------------	---------------------	-------------	----------------

2.7 Options

Figure 2-3 Options available with the drive

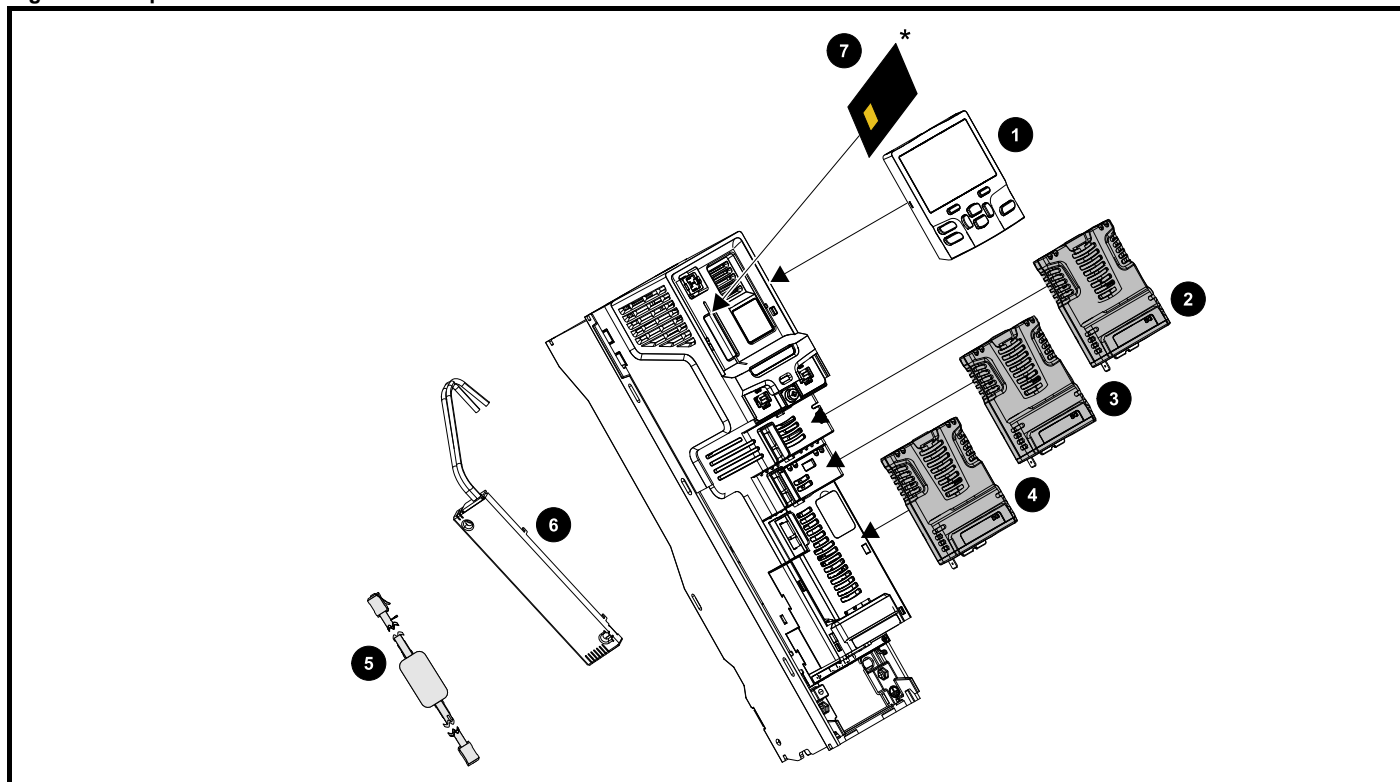

1. Keypad
2. Option module slot 1
3. Option module slot 2
4. Option module slot 3
5. CT USB Comms cable
6. Internal braking resistor (available on size 3, 4 and 5)
7. NV media card

* For further information, refer to Chapter 10 *NV Media Card Operation* on page 139.

Unidrive M option modules come in two different formats, a standard option module and a large option module. All standard option modules are color-coded in order to make identification easy, whereas the larger option module is black. All modules have an identification label on top of the module. Standard option modules can be installed to any of the available option slots on the drive, whereas the large option modules can only be installed to option slot 3. The following tables shows the color-code key and gives further details on their function.

Safety information	Product information	Mechanical installation	Electrical installation	Getting started	Basic parameters	Running the motor	Optimization	Drive communication	NV Media Card Operation	Onboard PLC	Advanced parameters	Diagnostics	UL information
--------------------	---------------------	-------------------------	-------------------------	-----------------	------------------	-------------------	--------------	---------------------	-------------------------	-------------	---------------------	-------------	----------------

Table 2-2 Option module identification

Type	Option module	Color	Name	Further Details
Feedback		N/A	15-way D-type converter	Drive encoder input converter Provides screw terminal interface for encoder wiring and spade terminal for shield
		N/A	Single ended encoder interface (15V or 24V)	Single ended encoder interface Provides an interface for single ended ABZ encoder signals, such as those from hall effect sensors. 15 V and 24 V versions are available
Fieldbus		N/A	KI-485 Adaptor	EIA 485 Comms Adaptor EIA 485 Comms adaptor provides EIA 485 communication interface. This adaptor supports 115 k Baud, node addresses between 1 to 16 and 8 1 NP M serial mode.
		Purple	SI-PROFIBUS	Profibus option PROFIBUS adapter for communications with the drive
		Medium Grey	SI-DeviceNet	DeviceNet option DeviceNet adapter for communications with the drive
		Light Grey	SI-CANopen	CANopen option CANopen adapter for communications with the drive
		Beige	SI-Ethernet	External Ethernet module that supports EtherNet/IP, Modbus TCP/IP and RTMoE. The module can be used to provide high speed drive access, global connectivity and integration with IT network technologies, such as wireless networking
		Yellow Green	SI-PROFINET V2	PROFINET V2 option PROFINET V2 adapter for communications with the drive Note: PROFINET V2 replaces PROFINET RT.
		Brown Red	SI-EtherCAT	EtherCAT option EtherCAT adapter for communications with the drive
Automation (I/O expansion)		Orange	SI-I/O	Extended I/O Increases the I/O capability by adding the following combinations: <ul style="list-style-type: none"> Digital I/O Digital Inputs Analog Inputs (differential or single ended) Analog Output Relays
Automation (Applications)		Moss Green	MCi200	Machine Control Studio Compatible Applications Processor 2nd processor for running pre-defined and/or customer created application software.
		Moss Green	MCi210	Machine Control Studio Compatible Applications Processor (with Ethernet communications) 2nd processor for running pre-defined and/or customer created application software with Ethernet communications.
		Black	SI-Applications Plus	SyPTPro Compatible Applications Processor (with CNet) 2nd processor for running pre-defined and/or customer created application software with CNet support (can only be used on Slot 3).
Feedback		Light Brown	SI-Encoder	Incremental encoder input interface module.
		Dark Brown	SI-Universal Encoder	Additional combined encoder input and output interface supporting Incremental, SinCos, HIPERFACE, EnDAT and SSI encoders.
Safety		Yellow	SI-Safety	Safety module that provides an intelligent, programmable solution to meet the IEC 61800-5-2 functional safety standard

Safety information	Product information	Mechanical installation	Electrical installation	Getting started	Basic parameters	Running the motor	Optimization	Drive communication	NV Media Card Operation	Onboard PLC	Advanced parameters	Diagnostics	UL information
--------------------	----------------------------	-------------------------	-------------------------	-----------------	------------------	-------------------	--------------	---------------------	-------------------------	-------------	---------------------	-------------	----------------

Table 2-3 Keypad identification





Type	Keypad	Name	Further Details
Keypad		KI-Keypad	LCD keypad option Keypad with a LCD display
		KI-Keypad RTC	LCD keypad option Keypad with a LCD display and real time clock
		Remote-Keypad RTC	Remote LCD keypad option Remote Keypad with a LCD display and real time clock
		Remote-Keypad	Remote LCD keypad option Remote Keypad with a LCD display

Table 2-4 Additional options

Type	Option	Name	Further Details
Back-up		SD Card Adaptor	SD Card Adaptor Allows the drive to use an SD card for drive back-up
		SMARTCARD	SMARTCARD Used for parameter back-up with the drive

3 Mechanical installation

3.1 Installing / removing option modules and keypads



Power down the drive before installing / removing the option module. Failure to do so may result in damage to the product.

CAUTION

Figure 3-1 Installation of a standard option module

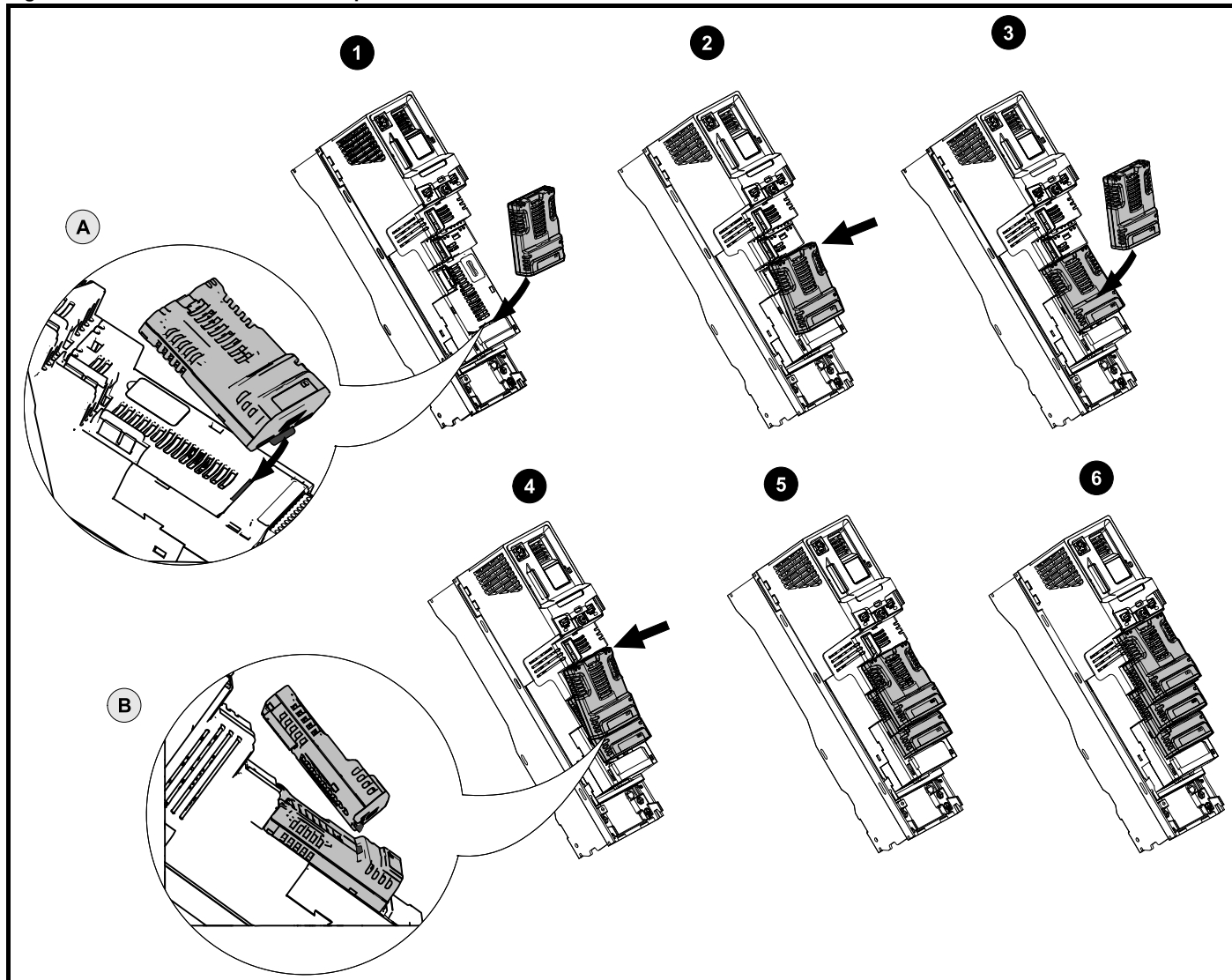

Installing the first option module

NOTE

Option module slots must be used in the following order: slot 3, slot 2 and slot 1 (refer to section 2.7 *Options* on page 16 for slot numbers).

- Move the option module in direction shown (1).
- Align and insert the option module tab in to the slot provided (2), this is highlighted in the detailed view (A).
- Press down on the option module until it clicks into place.

Installing the second option module

- Move the option module in direction shown (3).
- Align and insert the option module tab in to the slot provided on the already installed option module (4), this is highlighted in the detailed view (B).
- Press down on the option module until it clicks into place. Image (5) shows two option modules fully installed.

Installing the third option module

- Repeat the above process.

The drive has the facility for all three option module slots to be used at the same time, image (6) shows the three option modules installed.

Safety information	Product information	Mechanical installation	Electrical installation	Getting started	Basic parameters	Running the motor	Optimization	Drive communication	NV Media Card Operation	Onboard PLC	Advanced parameters	Diagnostics	UL information
--------------------	---------------------	--------------------------------	-------------------------	-----------------	------------------	-------------------	--------------	---------------------	-------------------------	-------------	---------------------	-------------	----------------

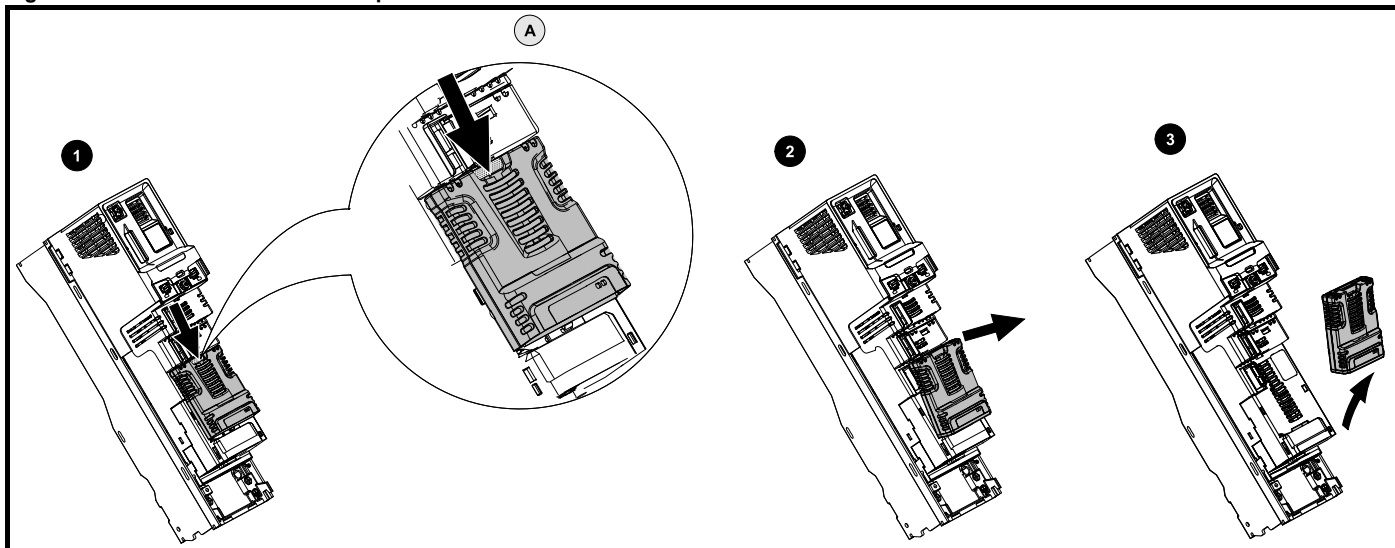
Figure 3-2 Removal of a standard option module

- Press down on the tab (1) to release the option module from the drive housing, the tab is highlighted in the detailed view (A).
- Tilt the option module towards you as shown (2).
- Totally remove the option module in direction shown (3).

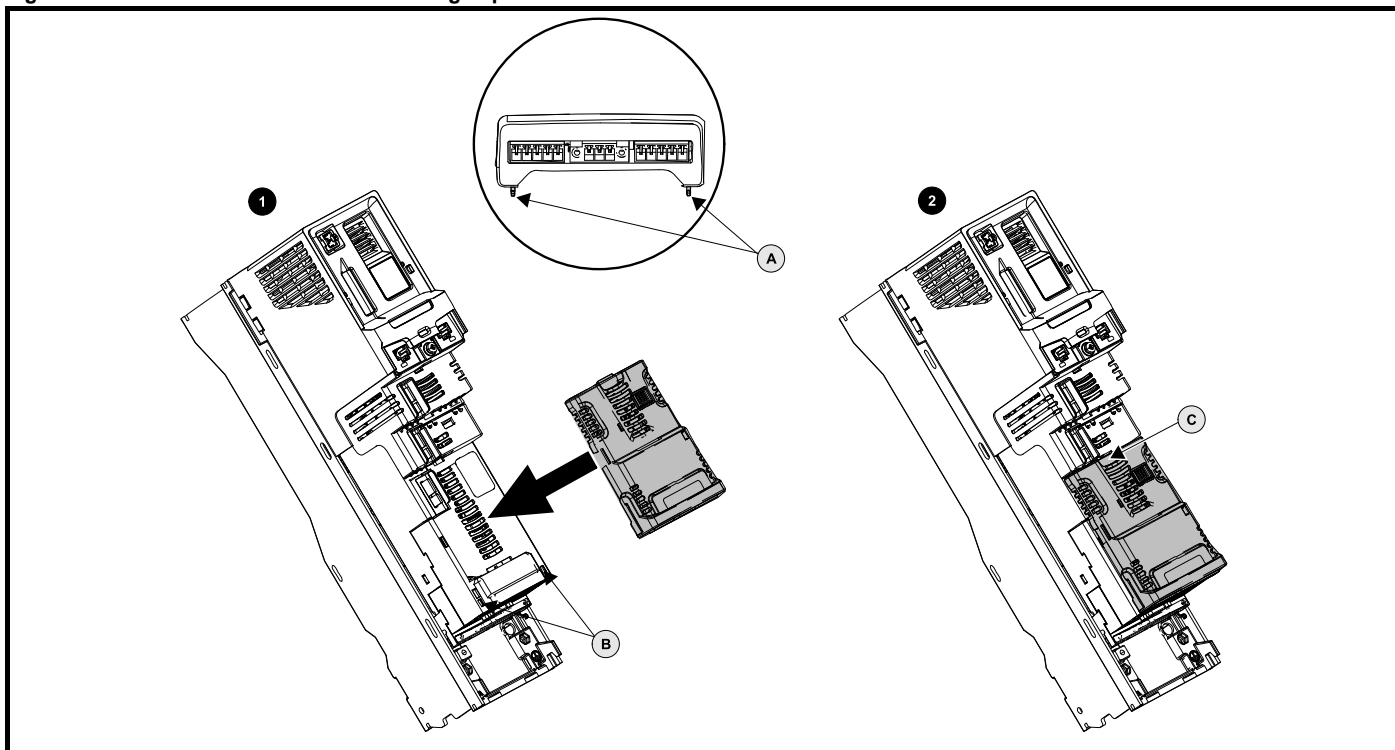
Figure 3-3 Installation and removal of a large option module**Installing a large option module**

- Move the option module in direction shown (1).
- Align and insert the option module tabs (A) into the slot provided (B).
- Press down on the option module until it clicks into place.

Removing a large option module

- Press down on the tab (2C), tilt the option module towards you and remove.

NOTE

The large option module can only be inserted into slot 3. Additional standard option modules can still be installed and used in slot 2 and slot 1.

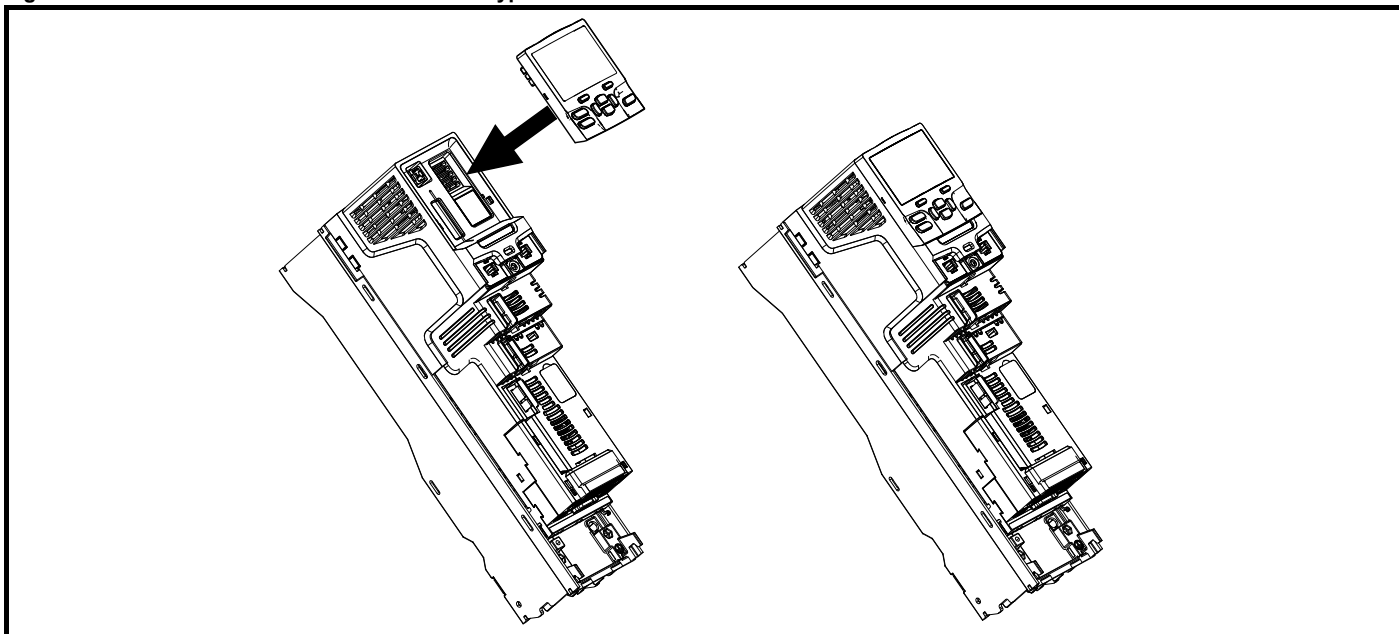
Figure 3-4 Installation and removal of the KI-Keypad

To install, align the keypad and press gently in the direction shown until it clicks into position.

To remove, reverse the installation instructions.

NOTE

The keypad can be installed / removed while the drive is powered up and running a motor, providing that the drive is not operating in keypad mode.

3.2 Real time clock battery replacement

Those keypads which have the real time clock feature contain a battery to ensure the clock works when the drive is powered down. The battery has a long life time but if the battery needs to be replaced or removed, follow the instructions below.

Low battery voltage is indicated by  low battery symbol on the keypad display.

Figure 3-5 KI-Keypad RTC (rear view)

Figure 3-5 above illustrates the rear view of the KI-Keypad RTC.

1. To remove the battery cover insert a flat head screwdriver into the slot as shown (1), push and turn anti-clockwise until the battery cover is released.
2. Replace the battery (the battery type is: CR2032).
3. Reverse point 1 above to replace battery cover.

NOTE

Ensure the battery is disposed of correctly.

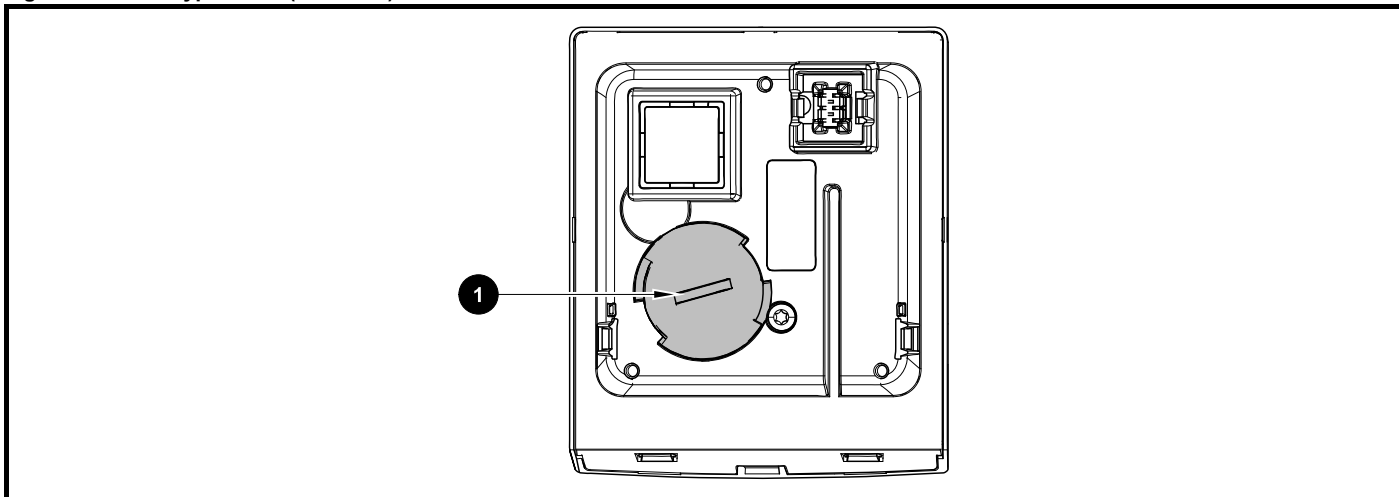
4 Electrical installation

4.1 24 Vdc supply

The 24 Vdc supply connected to control terminals 1 & 2 provides the following functions:

- It can be used to supplement the drive's own internal 24 V supply when multiple option modules are being used and the current drawn by these module is greater than the drive can supply.
- It can be used as a back-up power supply to keep the control circuits of the drive powered up when the line power supply is removed. This allows any fieldbus modules, application modules, encoders or serial communications to continue to operate.
- It can be used to commission the drive when the line power supply is not available, as the display operates correctly. However, the drive will be in the Under voltage trip state unless either line power supply or low voltage DC operation is enabled, therefore diagnostics may not be possible. (Power down save parameters are not saved when using the 24 V back-up power supply input).
- If the DC bus voltage is too low to run the main SMPS in the drive, then the 24 V supply can be used to supply all the low voltage power requirements of the drive. *Low Under Voltage Threshold Select* (06.067) must also be enabled for this to happen.

NOTE

On size 6 and larger, the power 24 Vdc supply (terminals 51, 52) must be connected to enable the 24 V dc supply to be used as a backup supply, when the line power supply is removed. If the power 24 Vdc supply is not connected none of the above mentioned functions can be used, "Waiting For Power Systems" will be displayed on the keypad and no drive operations are possible. The location of the power 24 Vdc can be identified from Figure 4-1 *Location of the 24 Vdc power supply connection on size 6* on page 22.

Table 4-1 24 Vdc Supply connections

Function	Sizes 3-5	Sizes 6-11
Supplement the drive's internal supply	Terminal 1, 2	Terminal 1, 2
Back-up supply for the control circuit	Terminal 1, 2	Terminal 1, 2 51, 52

The working voltage range of the control 24 V power supply is as follows:

1	0V (Common connection for all external devices)
2	+24 Vdc
Nominal operating voltage	24.0 Vdc
Minimum continuous operating voltage	19.2 V
Maximum continuous operating voltage	28.0 V
Minimum start up voltage	21.6 V
Maximum power supply requirement at 24 V	40 W
Recommended fuse	3 A, 50 Vdc

Minimum and maximum voltage values include ripple and noise. Ripple and noise values must not exceed 5 %.

The working range of the 24 V power supply is as follows:

51	0V (Common connection for all external devices)
52	+24 Vdc
Size 6	
Nominal operating voltage	24.0 Vdc
Minimum continuous operating voltage	18.6 Vdc
Maximum continuous operating voltage	28.0 Vdc
Minimum startup voltage	18.4 Vdc
Maximum power supply requirement	40 W
Recommended fuse	4 A @ 50 Vdc
Size 7 to 11	
Nominal operating voltage	24.0 Vdc
Minimum continuous operating voltage	19.2 Vdc
Maximum continuous operating voltage	30 Vdc (IEC), 26 Vdc (UL)
Minimum startup voltage	21.6 Vdc
Maximum power supply requirement	60 W
Recommended fuse	4 A @ 50 Vdc

Figure 4-1 Location of the 24 Vdc power supply connection on size 6

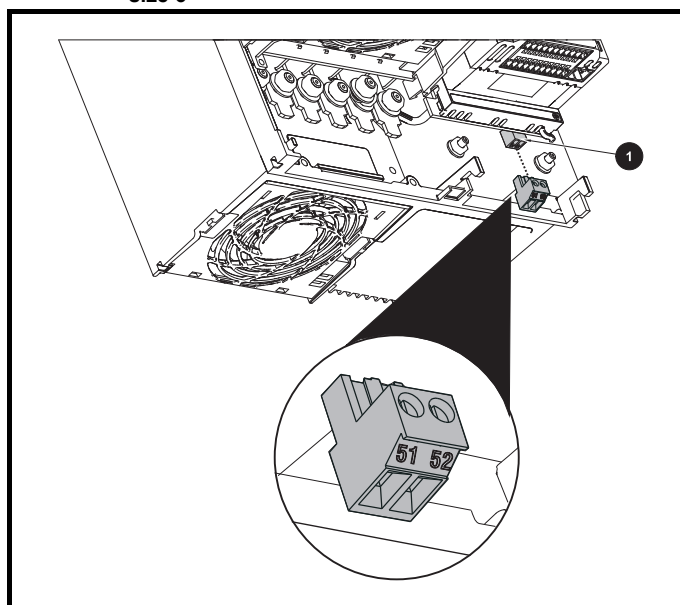

1. 24 Vdc power supply connection

Safety information	Product information	Mechanical installation	Electrical installation	Getting started	Basic parameters	Running the motor	Optimization	Drive communication	NV Media Card Operation	Onboard PLC	Advanced parameters	Diagnostics	UL information
--------------------	---------------------	-------------------------	--------------------------------	-----------------	------------------	-------------------	--------------	---------------------	-------------------------	-------------	---------------------	-------------	----------------

Figure 4-2 Location of the 24 Vdc power supply connection on size 7

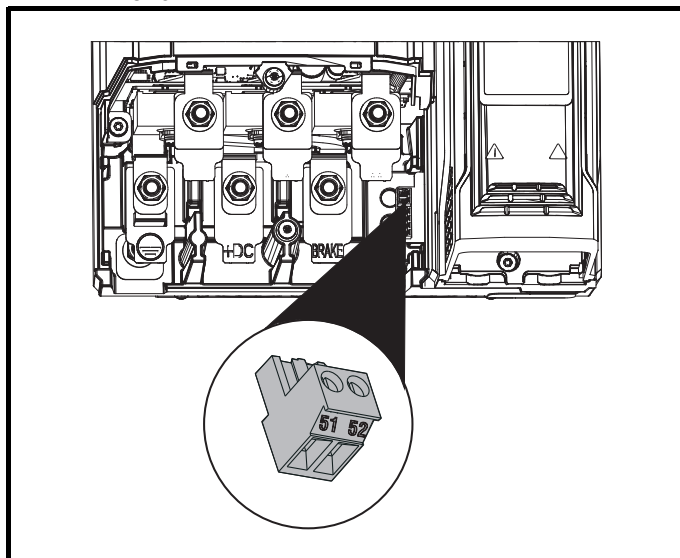
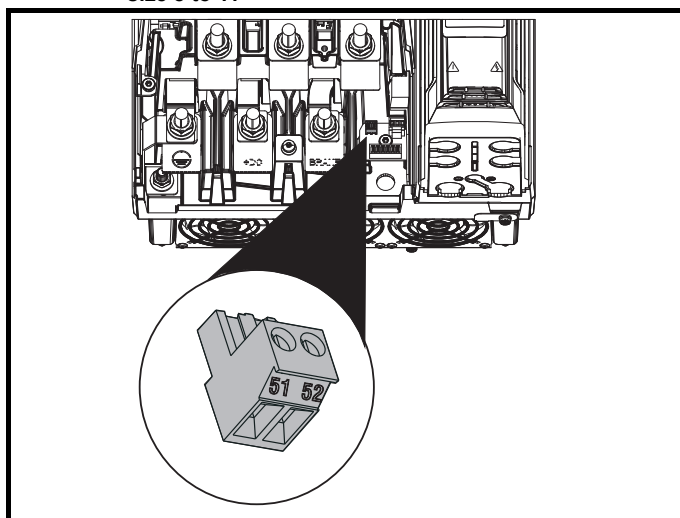

Figure 4-3 Location of the 24 Vdc power supply connection on size 8 to 11



4.2 Communication connections

The *Unidrive M700 / M702* drive offers Ethernet fieldbus communications and the *Unidrive M701* drive offers a 2 wire EIA 485 interface. This enables the drive set-up, operation and monitoring to be carried out with a PC or controller if required.

Care must be taken to ensure the correct interface is fitted before a connection is made to the interface, failure to ensure this may result in damage to the interface and/or communication device.

Both the Ethernet and EIA 485 interfaces use an RJ45 connector, the EIA 485 interface is identified by the number "485" printed on the front panel, and the Ethernet interface has the network logo.

Figure 4-4 Location of the comms connectors

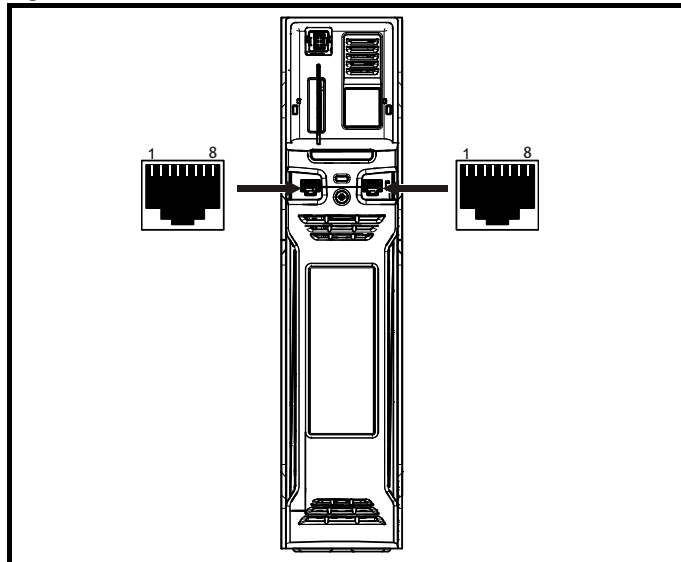

4.2.1 Unidrive M700 / M702 Ethernet fieldbus communications

The Ethernet option provides two RJ45 connections with an Ethernet switch for easy network creation.

Standard UTP (unshielded twisted pair) or STP (shielded twisted pair) cables are supported. It is recommended that a minimum specification CAT5e is used in new installations. As the drive supports the 'Auto cross-over detection' a cross-over cable is not required.

NOTE

The shell of the RJ45 connector is isolated from the 0V of the drive control terminals but it is connected to ground.

Table 4-2 Ethernet port pin-outs

Pin	Description
1	Transmit +
2	Transmit -
3	Receive +
4	N/A
5	N/A
6	Receive -
7	N/A
8	N/A

4.2.2 Unidrive M701 EIA 485 serial communications

The EIA 485 interface provides two parallel RJ45 connectors allowing easy daisy chaining. The drive only supports Modbus RTU protocol. See Table 4-3 for the connection details.

Safety information	Product information	Mechanical installation	Electrical installation	Getting started	Basic parameters	Running the motor	Optimization	Drive communication	NV Media Card Operation	Onboard PLC	Advanced parameters	Diagnostics	UL information
--------------------	---------------------	-------------------------	--------------------------------	-----------------	------------------	-------------------	--------------	---------------------	-------------------------	-------------	---------------------	-------------	----------------

NOTE

Standard Ethernet cables are not recommended for use when connecting drives on a EIA 485 network as they do not have the correct twisted pairs for the pinout of the serial comms port.



If an Ethernet network adaptor is inadvertently connected to a Unidrive-M701 EIA 485 drive, a low impedance load across the EIA 485 24 V is applied and if connected for a significant period of time can introduce the potential risk of damage.

Table 4-3 Serial communication port pin-outs

Pin	Function
1	120 Ω Termination resistor
2	RX TX
3	Isolated 0V
4	+24 V (100 mA) output
5	Isolated 0V
6	TX enable
7	RX\ TX\
8	RX\ TX\ (if termination resistors are required, link to pin 1)
Shell	Isolated 0V

Minimum number of connections are 2, 3, 7 and shield.

4.2.3 Unidrive M701 Isolation of the EIA 485 serial communications port

The serial communications port is double insulated and meets the requirements for SELV in EN 50178:1998.



In order to meet the requirements for SELV in IEC60950 (IT equipment) it is necessary for the control computer to be grounded. Alternatively, when a lap-top or similar device is used which has no provision for grounding, an isolation device must be incorporated in the communications lead.

An isolated serial communications lead has been designed to connect the drive to IT equipment (such as laptop computers), and is available from the supplier of the drive. See below for details:

Table 4-4 Isolated serial comms lead details

Part number	Description
4500-0096	CT USB Comms cable

The “isolated serial communications” lead has reinforced insulation as defined in IEC60950 for altitudes up to 3,000 m.

4.2.4 Communication networks and cabling

Any isolated signal circuit has the capability to become live through accidental contact with other conductors; as such they should always be double-insulated from live parts. The routing of network and signal wires should be done so as to avoid close proximity to mains voltage cabling.

4.2.5 Unidrive M701 EIA 485 Port polarization (biasing)

The Unidrive M701 EIA 485 serial communications port requires polarization (biasing) of the data lines.

The Modbus standard specifies that to prevent spurious triggering when there is no data being transmitted, the data lines are polarized (biased) with pull-apart resistors, one resistor from the RJ45 pin 2 connection (RX TX) to +V and the other resistor from the RJ45 pin 7 connection (RX / TX) to 0V. These resistors should be in the range 450 to 650 Ohms and fitted in the master controller.

4.2.6 Unidrive M701 EIA 485 Network termination

When a long-distance multi-drop EIA 485 system is used with high baud rates (above 38400) it may be necessary to fit a termination resistor of 120 Ω across the transmit and receive pair in order to reduce signal reflections.

4.3 Control connections

4.3.1 Unidrive M700 / M701 control connections

Table 4-5 The control connections consist of:

Function	Qty	Control parameters available	Terminal number
Differential analog input	1	Mode, offset, invert, scaling	5, 6
Single ended analog input	2	Mode, offset, invert, scaling, destination	7, 8
Analog output	2	Source, scaling	9, 10
Digital input	3	Destination, invert	27, 28, 29
Digital input / output	3	Input / output mode select, destination / source, invert, logic select	24, 25, 26
Relay	1	Source, invert	41, 42
Drive enable (Safe Torque Off)	1		31
+10 V User output	1		4
+24 V User output	1	Source, invert	22
0V common	6		1, 3, 11, 21, 23, 30, 51 (size 6 and larger)
+24V External input	1	Destination, invert	2

Key:

Destination parameter:	Indicates the parameter which is being controlled by the terminal / function
Source parameter:	Indicates the parameter being output by the terminal
Mode parameter:	Analog - indicates the mode of operation of the terminal, i.e. voltage 0-10 V, current 4-20 mA etc. Digital - indicates the mode of operation of the terminal, i.e. positive / negative logic (the Drive Enable terminal is fixed in positive logic), open collector.

All analog terminal functions can be programmed in menu 7.

All digital terminal functions (including the relay) can be programmed in menu 8.

The control circuits are isolated from the power circuits in the drive by basic insulation (single insulation) only. The installer must ensure that the external control circuits are insulated from human contact by at least one layer of insulation (supplementary insulation) rated for use at the AC supply voltage.

If the control circuits are to be connected to other circuits classified as Safety Extra Low Voltage (SELV) (e.g. to a personal computer), an additional isolating barrier must be included in order to maintain the SELV classification.

If any of the digital inputs (including the drive enable input) are connected in parallel with an inductive load (i.e. contactor or motor brake) then suitable suppression (i.e. diode or varistor) should be used on the coil of the load. If no suppression is used then over voltage spikes can cause damage to the digital inputs and outputs on the drive.

Ensure the logic sense is correct for the control circuit to be used. Incorrect logic sense could cause the motor to be started unexpectedly. Positive logic is the default state for the drive.

NOTE

Any signal cables which are carried inside the motor cable (i.e. motor thermistor, motor brake) will pick up large pulse currents via the cable capacitance. The shield of these signal cables must be connected to ground close to the point of exit of the motor cable, to avoid this noise current spreading through the control system.

NOTE

The Safe Torque Off drive enable terminal is a positive logic input only. It is not affected by the setting of *Input Logic Polarity* (08.029).

NOTE

The common 0V from analog signals should, wherever possible, not be connected to the same 0V terminal as the common 0V from digital signals. Terminals 3 and 11 should be used for connecting the 0V common of analog signals and terminals 21, 23 and 30 for digital signals. This is to prevent small voltage drops in the terminal connections causing inaccuracies in the analog signals.

NOTE

A two wire motor thermistor can be connected to analog input 3 by connecting the thermistor between terminal 8 and any 0V common terminal. It is possible to connect a 4-wire thermistor to analog input 3 as shown below. Pr 07.015 and Pr 07.046 need to be set-up for the thermistor type required.

Figure 4-5 Connection for PT100, PT1000 and PT2000 thermistors

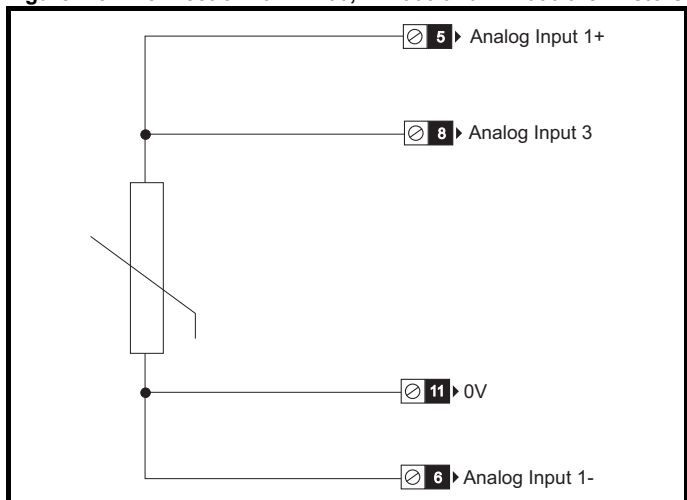
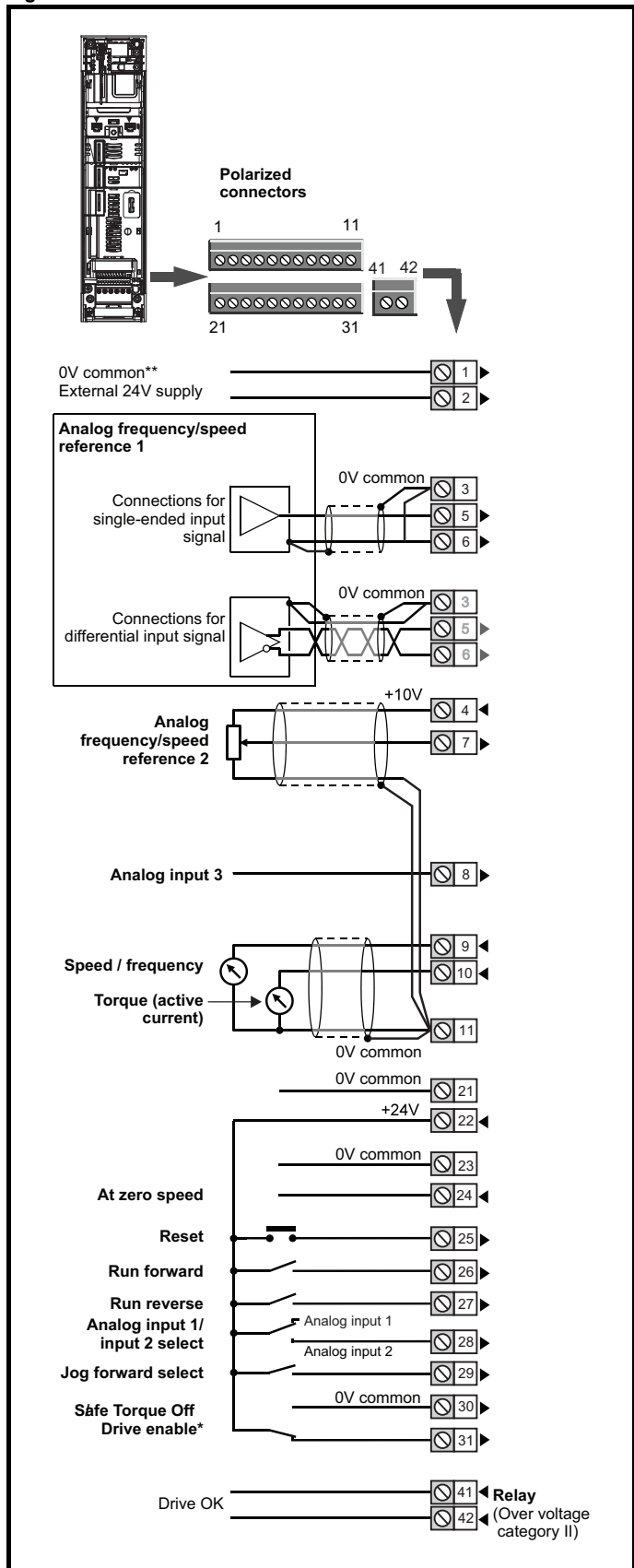

Figure 4-6 Default terminal functions



*The Safe Torque Off / Drive enable terminal is a positive logic input only.

NOTE

The 0V terminals on the Safe Torque Off are not isolated from each other and the 0V common.

Safety information	Product information	Mechanical installation	Electrical installation	Getting started	Basic parameters	Running the motor	Optimization	Drive communication	NV Media Card Operation	Onboard PLC	Advanced parameters	Diagnostics	UL information
--------------------	---------------------	-------------------------	--------------------------------	-----------------	------------------	-------------------	--------------	---------------------	-------------------------	-------------	---------------------	-------------	----------------

4.3.2 Unidrive M700 / M701 control terminal specification

1	0V common
Function	Common connection for all external devices

2	+24V external input
Function	To supply the control circuit without providing a supply to the power stage
Programmability	Can be used as digital input when using an external 24 V supply
Sample / update	2 ms
Nominal voltage	+24.0 Vdc
Minimum continuous operating voltage	+19.2 Vdc
Maximum continuous operating voltage	+28.0 Vdc
Minimum start-up voltage	21.6 Vdc
Recommended power supply	40 W 24 Vdc nominal
Recommended fuse	3 A, 50 Vdc

3	0V common
Function	Common connection for all external devices

4	+10V user output
Function	Supply for external analog devices
Voltage	10.2 V nominal
Voltage tolerance	±1 %
Nominal output current	10 mA
Protection	Current limit and trip @ 30 mA

Precision reference Analog input 1	
5	Non-inverting input
6	Inverting input
Default function	Frequency/speed reference
Type of input	Bipolar differential analog voltage or current, thermistor input
Mode controlled by:	Pr 07.007
Operating in Voltage mode	
Full scale voltage range	±10 V ±2 %
Maximum offset	±10 mV
Absolute maximum voltage range	±36 V relative to 0V
Working common mode voltage range	±13 V relative to 0V
Input resistance	≥100 kΩ
Monotonic	Yes (including 0V)
Dead band	None (including 0V)
Jumps	None (including 0V)
Maximum offset	20 mV
Maximum non linearity	0.3% of input
Maximum gain asymmetry	0.5 %
Input filter bandwidth single pole	~3 kHz
Operating in current mode	
Current ranges	0 to 20 mA ±5 %, 20 to 0 mA ±5 %, 4 to 20 mA ±5 %, 20 to 4 mA ±5 %
Maximum offset	250 μA
Absolute maximum voltage (reverse biased)	±36 V relative to 0V
Equivalent input resistance	≤300 Ω
Absolute maximum current	±30 mA
Operating in thermistor input mode (in conjunction with analog input 3), refer to Pr 07.046 and Figure 4-5 for further details.	
Trip threshold resistance	User defined in Pr 07.048
Short-circuit detection resistance	50 Ω ±40 %
Common to all modes	
Resolution	12 bits (11 bits plus sign)
Sample / update period	250 μs with destinations Pr 01.036 , Pr 01.037 , Pr 03.022 or Pr 04.008 in RFC-A and RFC-S modes. 4 ms for open loop mode and all other destinations in RFC-A or RFC-S modes.

Safety information	Product information	Mechanical installation	Electrical installation	Getting started	Basic parameters	Running the motor	Optimization	Drive communication	NV Media Card Operation	Onboard PLC	Advanced parameters	Diagnostics	UL information
--------------------	---------------------	-------------------------	--------------------------------	-----------------	------------------	-------------------	--------------	---------------------	-------------------------	-------------	---------------------	-------------	----------------

7 Analog input 2	
Default function	Frequency / speed reference
Type of input	Bipolar single-ended analog voltage or unipolar current
Mode controlled by...	Pr 07.011
Operating in voltage mode	
Full scale voltage range	±10 V ±2 %
Maximum offset	±10 mV
Absolute maximum voltage range	±36 V relative to 0V
Input resistance	≥100 k Ω
Operating in current mode	
Current ranges	0 to 20 mA ±5 %, 20 to 0 mA ±5 %, 4 to 20 mA ±5 %, 20 to 4 mA ±5 %
Maximum offset	250 μA
Absolute maximum voltage (reverse bias)	±36 V relative to 0V
Absolute maximum current	±30 mA
Equivalent input resistance	≤ 300 Ω
Common to all modes	
Resolution	12 bits (11 bits plus sign)
Sample / update	250 μs with destinations Pr 01.036 , Pr 01.037 or Pr 03.022 , Pr 04.008 in RFC-A or RFC-S. 4ms for open loop mode and all other destinations in RFC-A or RFC-S mode.

8 Analog input 3	
Default function	Voltage input
Type of input	Bipolar single-ended analog voltage, or thermistor input
Mode controlled by...	Pr 07.015
Operating in Voltage mode (default)	
Voltage range	±10 V ±2 %
Maximum offset	±10 mV
Absolute maximum voltage range	±36 V relative to 0V
Input resistance	≥100 k Ω
Operating in thermistor input mode	
Supported thermistor types	Din 44082, KTY 84, PT100, PT 1000, PT 2000, 2.0 mA
Trip threshold resistance	User defined in Pr 07.048
Reset resistance	User defined in Pr 07.049
Short-circuit detection resistance	50 Ω ±40 %
Common to all modes	
Resolution	12 bits (11 bits plus sign)
Sample / update period	4 ms

9 Analog output 1	
10 Analog output 2	
Terminal 9 default function	OL> Motor FREQUENCY output signal RFC> SPEED output signal
Terminal 10 default function	Motor active current
Type of output	Bipolar single-ended analog voltage
Operating in Voltage mode	
Voltage range	±10 V ±5 %
Maximum offset	±120 mV
Maximum output current	±20 mA
Load resistance	≥1 k Ω
Protection	20 mA max. Short circuit protection
Resolution	10-bit
Sample / update period	250 μs (output will only change at update the rate of the source parameter if slower)

11 0V common	
Function	Common connection for all external devices

21 0V common	
Function	Common connection for all external devices

22 +24 V user output (selectable)	
Terminal 22 default function	+24 V user output
Programmability	Can be switched on or off to act as a fourth digital output (positive logic only) by setting the source Pr 08.028 and source invert Pr 08.018
Nominal output current	100 mA combined with DIO3
Maximum output current	100 mA 200 mA (total including all Digital I/O)
Protection	Current limit and trip
Sample / update period	2 ms when configured as an output (output will only change at the update rate of the source parameter if slower)

23 0V common	
Function	Common connection for all external devices

Safety information	Product information	Mechanical installation	Electrical installation	Getting started	Basic parameters	Running the motor	Optimization	Drive communication	NV Media Card Operation	Onboard PLC	Advanced parameters	Diagnostics	UL information
--------------------	---------------------	-------------------------	--------------------------------	-----------------	------------------	-------------------	--------------	---------------------	-------------------------	-------------	---------------------	-------------	----------------

24	Digital I/O 1
25	Digital I/O 2
26	Digital I/O 3
Terminal 24 default function	AT ZERO SPEED output
Terminal 25 default function	DRIVE RESET input
Terminal 26 default function	RUN FORWARD input
Type	Positive or negative logic digital inputs, positive logic voltage source outputs
Input / output mode controlled by...	Pr 08.031 , Pr 08.032 and Pr 08.033
Operating as an input	
Logic mode controlled by...	Pr 08.029
Absolute maximum applied voltage range	-3 V to +30 V
Impedance	>2 mA @15 V (IEC 61131-2, type 1, 6.6 k Ω)
Input thresholds	10 V ±0.8 V (IEC 61131-2, type 1)
Operating as an output	
Nominal maximum output current	100 mA (DIO1 & 2 combined) 100 mA (DIO3 & 24 V User Output Combined)
Maximum output current	100 mA 200 mA (total including all Digital I/O)
Common to all modes	
Voltage range	0V to +24 V
Sample / Update period	2 ms (output will only change at the update rate of the source parameter)

27	Digital Input 4
28	Digital Input 5
Terminal 27 default function	RUN REVERSE input
Terminal 28 default function	Analog INPUT 1 / INPUT 2 select
Type	Negative or positive logic digital inputs
Logic mode controlled by...	Pr 08.029
Voltage range	0V to +24 V
Absolute maximum applied voltage range	-3 V to +30 V
Impedance	>2 mA @15 V (IEC 61131-2, type 1, 6.6 k Ω)
Input thresholds	10 V ±0.8 V (IEC 61131-2, type 1)
Sample / Update period	250 μs when configured as an input with destinations Pr 06.035 or Pr 06.036 . 600 μs when configured as an input with destination Pr 06.029 . 2 ms in all other cases.

29	Digital Input 6
Terminal 29 default function	JOG SELECT input
Type	Negative or positive logic digital inputs
Logic mode controlled by...	Pr 08.029
Voltage range	0V to +24 V
Absolute maximum applied voltage range	-3 V to +30 V
Impedance	>2 mA @15 V (IEC 61131-2, type 1, 6.6 k Ω)
Input thresholds	10 V ±0.8 V (IEC 61131-2, type 1)
Sample / Update period	2 ms

30	0V common
Function	Common connection for all external devices

Refer to section 4.5 *Safe Torque Off (STO)* on page 37 for further information.

31	Safe Torque Off function (drive enable)
Type	Positive logic only digital input
Voltage range	0V to +24 V
Absolute maximum applied voltage	30 V
Logic Threshold	10 V ±5 V
Low state maximum voltage for disable to SIL3 and PL e	5 V
Impedance	>4 mA @15 V (IEC 61131-2, type 1, 3.3 k Ω)
Low state maximum current for disable to SIL3 and PL e	0.5 mA
Response time	Nominal: 8 ms Maximum: 20 ms
The Safe Torque Off function may be used in a safety-related application in preventing the drive from generating torque in the motor to a high level of integrity. The system designer is responsible for ensuring that the complete system is safe and designed correctly according to the relevant safety standards. If the Safe Torque Off function is not required, this terminal is used for enabling the drive.	

41	Relay contacts
42	Relay contacts
Default function	Drive OK indicator
Contact voltage rating	240 Vac, Installation over-voltage category II
Contact maximum current rating	2 A AC 240 V 4 A DC 30 V resistive load 0.5 A DC 30 V inductive load (L/R = 40 ms)
Contact minimum recommended rating	12 V 100 mA
Contact type	Normally open
Default contact condition	Closed when power applied and drive OK
Update period	4 ms

51	0V (Common connection for all external devices)
52	+24 Vdc
Size 6	
Nominal operating voltage	24.0 Vdc
Minimum continuous operating voltage	18.6 Vdc
Maximum continuous operating voltage	28.0 Vdc
Minimum startup voltage	18.4 Vdc
Maximum power supply requirement	40 W
Recommended fuse	4 A @ 50 Vdc
Size 7 to 11	
Nominal operating voltage	24.0 Vdc
Minimum continuous operating voltage	19.2 Vdc
Maximum continuous operating voltage	30 Vdc (IEC), 26 Vdc (UL)
Minimum startup voltage	21.6 Vdc
Maximum power supply requirement	60 W
Recommended fuse	4 A @ 50 Vdc



To prevent the risk of a fire hazard in the event of a fault, a fuse or other over-current protection must be installed in the relay circuit.

4.3.3 Unidrive M702 control connections

Table 4-6 The control connections consist of:

Function	Qty	Control parameters available	Terminal number
Single ended analog input*	1	Mode, destination	8
Digital input*	2	Destination, invert, logic select	7, 8
Digital output	2	source, invert	4, 5
Relay	1	Source, invert	41, 42
Drive enable (Safe Torque Off)	2		11, 13
+24 V User output	1	Source, invert	2
0V common	5		1, 3, 6, 10, 12
+24 V External input	1	Destination, invert	9

* From date code 1710, control terminal 8 on the Unidrive M702 can be a dual-purpose input which can be configured as either a motor thermistor input (Analog Input 3) or a digital input (Digital Input 5).

Key:

Destination parameter:	Indicates the parameter which is being controlled by the terminal / function
Source parameter:	Indicates the parameter being output by the terminal
Mode parameter:	Analog - indicates the mode of operation of the thermistor protection (disabled, temperature, temperature and short).

All digital terminal functions (including the relay) can be programmed in menu 8.



WARNING

The control circuits are isolated from the power circuits in the drive by basic insulation (single insulation) only. The installer must ensure that the external control circuits are insulated from human contact by at least one layer of insulation (supplementary insulation) rated for use at the AC supply voltage.



WARNING

If the control circuits are to be connected to other circuits classified as Safety Extra Low Voltage (SELV) (e.g. to a personal computer), an additional isolating barrier must be included in order to maintain the SELV classification.



CAUTION

If any of the digital inputs (including the drive enable input) are connected in parallel with an inductive load (i.e. contactor or motor brake) then suitable suppression (i.e. diode or varistor) should be used on the coil of the load. If no suppression is used then over voltage spikes can cause damage to the digital inputs and outputs on the drive.



CAUTION

Ensure the logic sense is correct for the control circuit to be used. Incorrect logic sense could cause the motor to be started unexpectedly. Positive logic is the default state for the drive.

NOTE

Any signal cables which are carried inside the motor cable (i.e. motor thermistor, motor brake) will pick up large pulse currents via the cable capacitance. The shield of these signal cables must be connected to ground close to the point of exit of the motor cable, to avoid this noise current spreading through the control system.

Figure 4-7 Default terminal functions

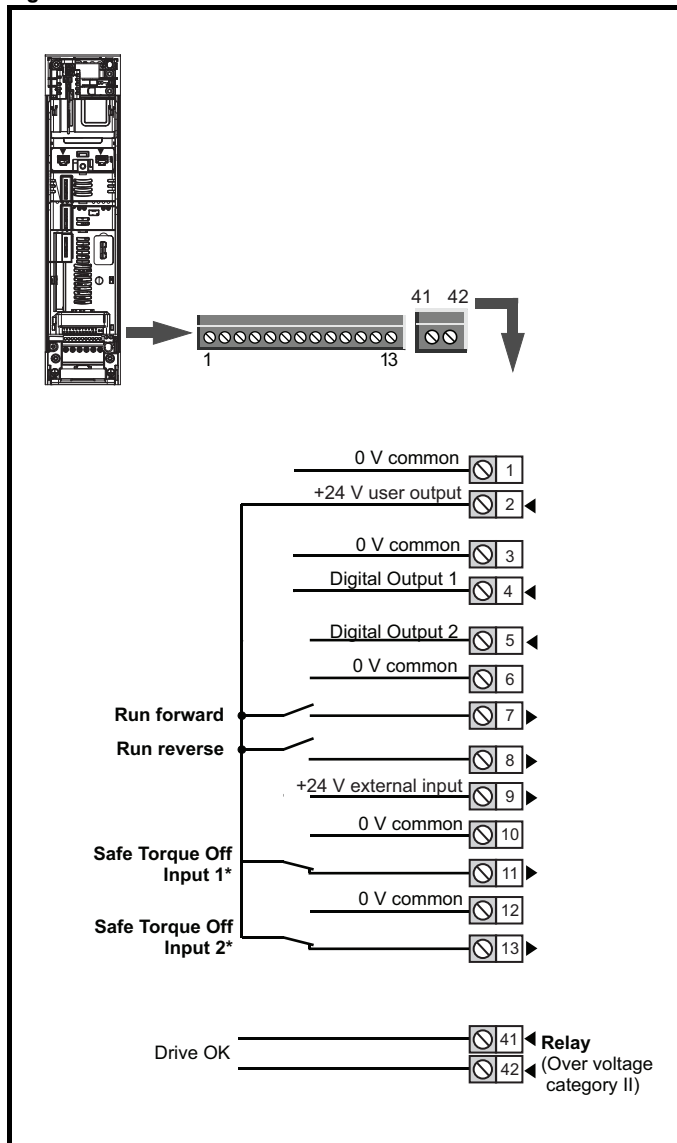

*The Safe Torque Off / Drive enable terminal is a positive logic input only.

Safety information	Product information	Mechanical installation	Electrical installation	Getting started	Basic parameters	Running the motor	Optimization	Drive communication	NV Media Card Operation	Onboard PLC	Advanced parameters	Diagnostics	UL information
--------------------	---------------------	-------------------------	--------------------------------	-----------------	------------------	-------------------	--------------	---------------------	-------------------------	-------------	---------------------	-------------	----------------

4.3.4 Unidrive M702 control terminal specification

1	0V common
Function	Common connection for all external devices

2	+24 V user output (selectable)
Terminal 2 default function	+24 V user output
Programmability	Can be switched on or off to act as a fourth digital output (positive logic only) by setting the source Pr 08.028 and source invert Pr 08.018
Nominal output current	100 mA
Maximum output current	100 mA 200 mA (total including all Digital I/O)
Protection	Current limit and trip
Sample / update period	2 ms when configured as an output (output will only change at the update rate of the source parameter if slower)

3	0V common
Function	Common connection for all external devices

4	Digital Output 1
5	Digital Output 2
Terminal 4 default function	AT ZERO SPEED output
Terminal 5 default function	
Type	Positive logic voltage source outputs
Operating as an output	
Nominal maximum output current	100 mA (DO1 & 2 combined)
Maximum output current	100 mA 200 mA (total including all Digital I/O)
Common to all modes	
Voltage range	0V to +24 V
Sample / Update period	2 ms (output will only change at the update rate of the source parameter)

6	0V common
Function	Common connection for all external devices

7	Digital Input 4
8	Digital Input 5
Terminal 7 default function	RUN FORWARD input
Terminal 8 default function	RUN REVERSE input
Type	Positive logic only digital inputs
Logic mode controlled by...	Pr 08.029
Voltage range	0V to +24 V
Absolute maximum applied voltage range	-3 V to +30 V
Impedance	>2 mA @15 V (IEC 61131-2, type 1, 6.6 k Ω)
Input thresholds	10 V ±0.8 V (IEC 61131-2, type 1)
Sample / Update period	250 μs when configured as an input with destinations Pr 06.035 or Pr 06.036 . 600 μs when configured as an input with destination Pr 06.029 . 2 ms in all other cases.

From date code 1710, control terminal 8 on the Unidrive M702 can be a dual purpose input which can be configured as either a motor thermistor input (Analog Input 3) or a digital input (Digital Input 5).

Terminal 8, by default, is set as a digital input (RUN REVERSE) but can be configured to be a motor protection thermistor input by changing *Analog Input 3 Mode* (07.015) from *Disable* (10) to either *Therm Short Cct* (7) or *Thermistor* (8).

8	Analog Input 3
Function	Thermistor input
Supported thermistor types	DIN44082, KTY84, PT100 (2W), PT1000 (2W), PT2000 (2W)
Trip threshold resistance	User defined in Pr 07.048
Reset resistance	User defined in Pr 07.049
Short-circuit detection resistance	50 Ω ±40 %
Resolution	12 bits (11 bits plus sign)
Sample / update period	4 ms

The thermistor is connected between terminal 8 and any 0V common terminal.

Figure 4-8 Motor thermistor connection

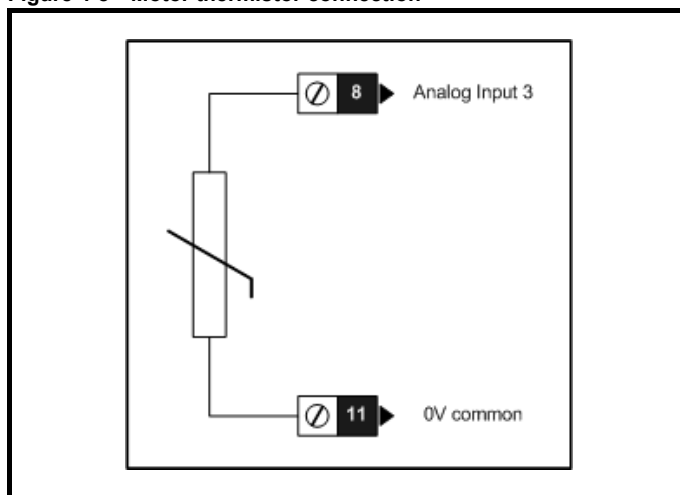

9	+24 V external input
Function	To supply the control circuit without providing a supply to the power stage
Programmability	Can be used as a digital input when using an external 24 Vdc
Sample / Update period	2 ms
Nominal voltage	+24.0 Vdc
Minimum continuous operating voltage	+19.2 Vdc
Maximum continuous operating voltage	+28.0 Vdc
Minimum start-up voltage	21.6 Vdc
Recommended power supply	40 W 24 Vdc nominal
Recommended fuse	3 A, 50 Vdc

10	0V common
Function	Common connection for all external devices

12	0V common
Function	Common connection for all external devices

11	Safe Torque Off function input 1 (drive enable)
13	Safe Torque Off function input 2 (drive enable)
Type	Positive logic only digital input
Voltage range	0V to +24 V
Absolute maximum applied voltage	30 V
Logic Threshold	10 V ± 5 V
Low state maximum voltage for disable to SIL3 and PL e	5 V
Impedance	>4 mA @15 V (IEC 61131-2, type 1,3.3 k Ω)
Low state maximum current for disable to SIL3 and PL e	0.5 mA
Response time	Nominal: 8 ms Maximum: 20 ms
The Safe Torque Off function may be used in a safety-related application in preventing the drive from generating torque in the motor to a high level of integrity. The system designer is responsible for ensuring that the complete system is safe and designed correctly according to the relevant safety standards. If the Safe Torque Off function is not required, these terminals are used for enabling the drive.	

Refer to section 4.5 *Safe Torque Off (STO)* on page 37 for further information.

41	Relay contacts
42	
Default function	Drive OK indicator
Contact voltage rating	240 Vac, Installation over-voltage category II
Contact maximum current rating	2 A AC 240 V 4 A DC 30 V resistive load 0.5 A DC 30 V inductive load (L/R = 40 ms)
Contact minimum recommended rating	12 V 100 mA
Contact type	Normally open
Default contact condition	Closed when power applied and drive OK
Update period	4 ms

51	0V (Common connection for all external devices)
52	+24 Vdc
Size 6	
Nominal operating voltage	24.0 Vdc
Minimum continuous operating voltage	18.6 Vdc
Maximum continuous operating voltage	28.0 Vdc
Minimum startup voltage	18.4 Vdc
Maximum power supply requirement	40 W
Recommended fuse	4 A @ 50 Vdc
Size 7 to 11	
Nominal operating voltage	24.0 Vdc
Minimum continuous operating voltage	19.2 Vdc
Maximum continuous operating voltage	30 Vdc (IEC), 26 Vdc (UL)
Minimum startup voltage	21.6 Vdc
Maximum power supply requirement	60 W
Recommended fuse	4 A @ 50 Vdc

	<p>To prevent the risk of a fire hazard in the event of a fault, a fuse or other over-current protection must be installed in the relay circuit.</p>
WARNING	

4.4 Position feedback connections

The following functions are provided via the 15-way high density D-type connector on the drive:

- Two position feedback interfaces (P1 and P2).
- One encoder simulation output.
- Two freeze trigger inputs (marker inputs).
- One thermistor input.

The P1 position interface is always available but the availability of the P2 position interface and the encoder simulation output depends on the position feedback device used on the P1 position interface, as shown in Table 4-9.

4.4.1 Location of position feedback connector

Figure 4-9 Location of the position feedback

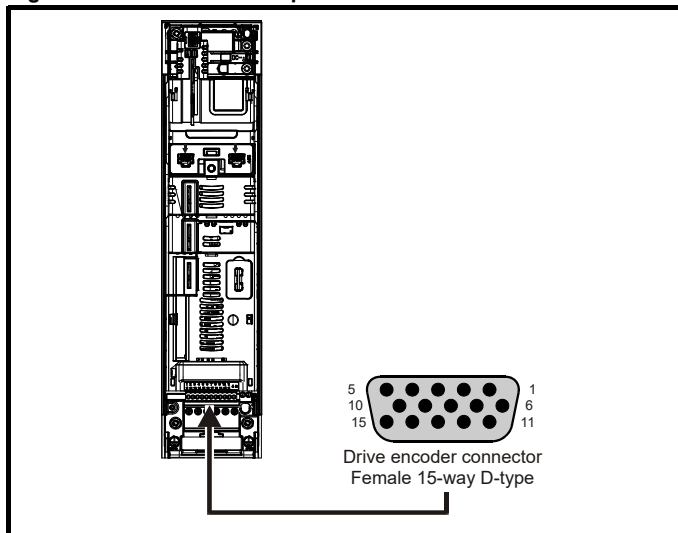

Safety information	Product information	Mechanical installation	Electrical installation	Getting started	Basic parameters	Running the motor	Optimization	Drive communication	NV Media Card Operation	Onboard PLC	Advanced parameters	Diagnostics	UL information
--------------------	---------------------	-------------------------	--------------------------------	-----------------	------------------	-------------------	--------------	---------------------	-------------------------	-------------	---------------------	-------------	----------------

4.4.2 Compatible position feedback devices

Table 4-7 Supported feedback devices on the P1 position interface

Encoder type	Pr 3.038 setting
Quadrature incremental encoders with or without marker pulse	AB (0)
Quadrature incremental encoders with UVW commutation signals for absolute position for permanent magnet motors with or without marker pulse	AB Servo (3)
Forward / reverse incremental encoders with or without marker pulse	FR (2)
Forward / reverse incremental encoders with UVW commutation signals for absolute position for permanent magnet motors with or without marker pulse	FR Servo (5)
Frequency and direction incremental encoders with or without marker pulse	FD (1)
Frequency and direction incremental encoders with UVW commutation signals for absolute position for permanent magnet motors with or without marker pulse	FD Servo (4)
Sincos incremental encoders	SC (6)
Sincos incremental with commutation signals	SC Servo (12)
Heidenhain sincos encoders with EnDat comms for absolute position	SC EnDat (9)
Stegmann sincos encoders with Hiperface comms for absolute position	SC Hiperface (7)
Sincos encoders with SSI comms for absolute position	SC SSI (11)
Sincos encoders with BiSS (type C) comms for absolute position	SC BiSS (17)
Sincos incremental with absolute position from single sin and cosine signals	SC SC (15)
SSI encoders (Gray code or binary)	SSI (10)
EnDat communication only encoders	EnDat (8)
BiSS (type C) communication only encoders	BiSS (13)
Resolver	Resolver (14)
UVW commutation only encoders*	Commutation only (16)

* This feedback device provides very low resolution feedback and should not be used for applications requiring a high level of performance

Table 4-8 Supported feedback devices on the P2 position interface

Encoder type	Pr 3.138 setting
Quadrature incremental encoders with or without marker pulse	AB (1)
Frequency and direction incremental encoders with or without marker pulse	FD (2)
Forward / reverse incremental encoders with or without marker pulse	FR (3)
EnDat communication only encoders	EnDat (4)
SSI encoders (Gray code or binary)	SSI (5)
BiSS communication only encoders	BiSS (6)

Table 4-9 shows the possible combinations of position feedback device types connected to the P1 and P2 position interfaces and the availability of the encoder simulation output.

Table 4-9 Availability of the P2 position feedback interface and the encoder simulation output

Functions		
P1 Position feedback interface	P2 Position feedback interface	Encoder Simulation Output
AB Servo FD Servo FR Servo SC Servo SC SC Commutation only	None	None
AB FD FR SC Resolver SC Hiperface	AB, FD, FR EnDat, BiSS, SSI	None
SC EnDat SC SSI	AB, FD, FR (No Z marker pulse input)	None
	EnDat, BiSS, SSI (with freeze input)	
	None	No Z marker pulse output
EnDat BiSS SSI	AB, FD, FR EnDat, BiSS, SSI (with freeze input)	None
	None	Full
	EnDat, BiSS, SSI	No Z marker pulse output

The priority of the position feedback interfaces and the encoder simulation output on the 15-way D-type is assigned in the following order from the highest priority to the lowest.

- P1 position interface (highest)
- Encoder simulation output
- P2 position interface (lowest)

For example, if an AB Servo type position feedback device is selected for use on the P1 position interface, then both the encoder simulation output and the P2 position interface will not be available as this device uses all connections of the 15-way D-type connector. Also, if an AB type position feedback device is selected for use on the P1 position interface and Pr **03.085** is set to a valid source for the encoder simulation output, then the P2 position interface will not be available.

Depending on the device type used on the P1 position interface, the encoder simulation output may not be able support a marker pulse output (e.g. SC EnDat or SC SSI device types). Pr **03.086** shows the status of the encoder simulation output indicating whether the output is disabled, no marker pulse is available or full encoder simulation is available.

NOTE

When using the P1 and P2 position interfaces and the encoder simulation output together, the P2 position interface uses alternative connections on the 15-way D-type connector. Pr **03.172** shows the status of the P2 position interface and indicates if alternative connections are being used for the P2 position interface.

4.4.3 Position feedback connection details

Table 4-10 P1 Position feedback connection details

P1 Position feedback interface Pr 03.038	Connections														
	1	2	3	4	5	6	7	8	9	10	11	12	13	14	15
AB (0)	A	A\	B	B\	Z	Z\									
FD (1)	F	F\	D	D\	Z	Z\									
FR (2)	F	F\	R	R\	Z	Z\									
AB Servo (3)	A	A\	B	B\	Z	Z\	U	U\	V	V\	W	W\			
FD Servo (4)	F	F\	D	D\	Z	Z\	U	U\	V	V\	W	W\			
FR Servo (5)	F	F\	R	R\	Z	Z\	U	U\	V	V\	W	W\			
SC (6)	A (Cos)	A\ (Cos\)	B (Sin)	B\ (Sin\)	Z	Z\									
SC Hiperface (7)	Cos	Cosref	Sin	Sinref	DATA	DATA\									
EnDat (8)	DATA	DATA\	CLK	CLK\	Freeze	Freeze\									
SC EnDat (9)	A	A\	B	B\	DATA	DATA\					CLK	CLK\	+V	0V	Th
SSI (10)	DATA	DATA\	CLK	CLK\	Freeze	Freeze\									
SC SSI (11)	A (Cos)	A\ (Cos\)	B (Sin)	B\ (Sin\)	DATA	DATA\					CLK	CLK\			
SC Servo (12)	A (Cos)	A\ (Cos\)	B (Sin)	B\ (Sin\)	Z	Z\	U	U\	V	V\	W	W\			
BiSS (13)	DATA	DATA\	CLK	CLK\	Freeze	Freeze\									
Resolver (14)	Cos H	Cos L	Sin H	Sin L	Ref H	Ref L									
SC SC (15)	A (Cos)	A\ (Cos\)	B (Sin)	B\ (Sin\)	Z	Z\	C*1	C*1	D*2	D*2	Freeze2	Freeze2\			
Commutation Only (16)							U	U\	V	V\	W	W\			
SC BiSS (17)	A	A\	B	B\	DATA	DATA\					CLK	CLK\			

*1 - One cosine wave per revolution

*2 - One sine wave per revolution

Greyed cells are for P2 position feedback connections or simulated encoder outputs.

NOTE

Freeze and Freeze\ on terminals 5 and 6 are for Freeze input 1. Freeze2 and Freeze2\ on terminals 11 and 12 are for Freeze input 2.

Safety information	Product information	Mechanical installation	Electrical installation	Getting started	Basic parameters	Running the motor	Optimization	Drive communication	NV Media Card Operation	Onboard PLC	Advanced parameters	Diagnostics	UL information
--------------------	---------------------	-------------------------	--------------------------------	-----------------	------------------	-------------------	--------------	---------------------	-------------------------	-------------	---------------------	-------------	----------------

Table 4-11 P2 Position feedback and encoder simulation output connection details

P1 Position feedback interface Pr 03.038	P2 Position feedback interface Pr 03.138	Encoder Simulation Output	Connections							
			5	6	7	8	9	10	11	12
AB (0) FD (1) FR (2) SC (6) SC Hiperface (7) Resolver (14)	AB (1)	Disabled* ¹			A	A\	B	B\	Z	Z\
	FD (2)				F	F\	D	D\	Z	Z\
	FR (3)				F	F\	R	R\	Z	Z\
	EnDat (4) SSI (5) BiSS (6)				DATA	DATA\	CLK	CLK\	Freeze2	Freeze2\
	None (0)	AB			Asim	Asim\	Bsim	Bsim\	Zsim	Zsim\
		FD			Fsim	Fsim\	Dsim	Dsim\	Zsim	Zsim\
		FR			Fsim	Fsim\	Rsim	Rsim\	Zsim	Zsim\
		SSI			DATAsim	DATAsim\	CLKsim	CLKsim\		
SC EnDat (9) SC SSI (11)	AB (1)	Disabled* ¹			A	A\	B	B\		
	FD (2)				F	F\	D	D\		
	FR (3)				F	F\	R	R\		
	EnDat (4) SSI (5) BiSS (6)				DATA	DATA\	CLK	CLK\		
	None (0)	AB			Asim	Asim\	Bsim	Bsim\		
		FD			Fsim	Fsim\	Dsim	Dsim\		
		FR			Fsim	Fsim\	Rsim	Rsim\		
		SSI			DATAsim	DATAsim\	CLKsim	CLKsim\		
EnDat (8) SSI (10) BiSS (13)	AB (1)	Disabled* ¹			A	A\	B	B\	Z	Z\
	FD (2)				F	F\	D	D\	Z	Z\
	FR (3)				F	F\	R	R\	Z	Z\
	EnDat (4) SSI (5) BiSS (6)				DATA	DATA\	CLK	CLK\	Freeze2	Freeze2\
	None (0)	AB			Asim	Asim\	Bsim	Bsim\	Zsim	Zsim\
		FD			Fsim	Fsim\	Dsim	Dsim\	Zsim	Zsim\
		FR			Fsim	Fsim\	Rsim	Rsim\	Zsim	Zsim\
		SSI			DATAsim	DATAsim\	CLKsim	CLKsim\		
EnDat (8) SSI (10) BiSS (13) (with no Freeze inputs)	EnDat (4) SSI (5) BiSS (6)	AB	DATA	DATA\	Asim	Asim\	Bsim	Bsim\	CLK	CLK\
		FD	DATA	DATA\	Fsim	Fsim\	Dsim	Dsim\	CLK	CLK\
		FR	DATA	DATA\	Fsim	Fsim\	Rsim	Rsim\	CLK	CLK\
		SSI	DATA	DATA\	DATAsim	DATAsim\	CLKsim	CLKsim\	CLK	CLK\

*¹ The encoder simulation output is disabled when Pr 03.085 is set to zero.

NOTE

The termination resistors are always enabled on the P2 position interface. Wire break detection is not available when using AB, FD or FR position feedback device types on the P2 position interface.

4.4.4 Position feedback terminal specifications

1	A,F, Cosref, Data, Cos H
2	A,F Cosref, Data, Cos L
AB (0), FD (1), FR (2), AB Servo (3), FD Servo(4), FR Servo (5)	
Type	EIA 485 differential receivers
Maximum input frequency	500 kHz
Line loading	< 2 unit loads
Line termination components	120 Ω (switchable)
Working common mode range	-7 V to +12 V
SC Hiperface (7), SC EnDat (9), SC SSI (11), SC Servo (12), SC SC (15)	
Type	Differential voltage
Maximum Signal level	1.25 V peak to peak (sin with regard to sinref and cos with regard to cosref)
Maximum input frequency	See Table 4-12
Maximum applied differential voltage and common mode voltage range	±4 V
Resolution: The sine wave frequency can be up to 500 kHz but the resolution is reduced at high frequency. Table 4-12 shows the number of bits of interpolated information at different frequencies and with different voltage levels at the drive encoder port	
EnDat (8), SSI (10), BiSS (13)	
Type	EIA 485 differential receivers
Maximum input frequency	4 MHz
Line termination components	120 Ω (switchable)
Working common mode range	-7 V to +12 V
Resolver (14)	
Type	2 Vrms sinusoidal signal
Operating Frequency	6 - 8 kHz
Input voltage	0.6 Vrms
Minimum impedance	85 Ω
Common to All	
Absolute maximum applied voltage relative to 0V	-9 V to 14 V

NOTE

The position feedback input will accept 5 V TTL differential signals.

3	B, D, R Sinref, Clock, Sin H
4	B, D, R, Sinref, Clock, Sin L
AB (0), FD (1), FR (2), AB Servo (3), FD Servo(4), FR Servo (5)	
Type	EIA 485 differential receivers
Maximum input frequency	500 kHz
Line loading	< 2 unit loads
Line termination components	120 Ω (switchable)
Working common mode range	-7 V to +12 V
SC Hiperface (7), SC EnDat (9), SC SSI (11), SC Servo (12), SC SC (15)	
Type	Differential voltage
Maximum Signal level	1.25 V peak to peak (sin with regard to sinref and cos with regard to cosref)
Maximum input frequency	See Table 4-12
Maximum applied differential voltage and common mode voltage range	±4 V
Resolution: The sine wave frequency can be up to 500 kHz but the resolution is reduced at high frequency. Table 4-12 shows the number of bits of interpolated information at different frequencies and with different voltage levels at the drive encoder port	
EnDat (8), SSI (10), BiSS (13)	
Type	EIA 485 differential receivers
Maximum input frequency	4 MHz
Line termination components	120 Ω (switchable)
Working common mode range	-7 V to +12 V
Resolver (14)	
Type	2 Vrms sinusoidal signal
Operating Frequency	6 – 8 kHz
Input voltage	0.6 Vrms
Minimum impedance	85 Ω
Common to All	
Absolute maximum applied voltage relative to 0V	-9 V to 14 V

Safety information	Product information	Mechanical installation	Electrical installation	Getting started	Basic parameters	Running the motor	Optimization	Drive communication	NV Media Card Operation	Onboard PLC	Advanced parameters	Diagnostics	UL information
--------------------	---------------------	-------------------------	-------------------------	-----------------	------------------	-------------------	--------------	---------------------	-------------------------	-------------	---------------------	-------------	----------------

5	Z, Data, Freeze, Ref H
6	Z\, Data\, Freeze\, Ref L
AB (0), FD (1), FR (2), AB Servo (3), FD Servo(4), FR Servo (5), SC SC (15)	
Type	EIA 485 differential receivers
Maximum input frequency	512 kHz
Line loading	< 2 unit loads
Line termination components	120 Ω (switchable)
Working common mode range	-7 V to +12 V
SC Hiperface (7), SC EnDat (9), SC SSI (11), SC Servo (12)	
Type	EIA 485 differential receivers
Maximum input frequency	4 MHz
Line termination components	120 Ω (switchable)
Working common mode range	-7 V to +12 V
EnDat (8), SSI (10), BiSS (13)	
Type	EIA 485 differential receivers
Maximum input frequency	4 MHz
Line termination components	120 Ω (switchable)
Working common mode range	-7 V to +12 V
Resolver (14)	
Type	Differential voltage
Nominal voltage	0 – 2 Vrms depending on turns ratio
Operating frequency	6 - 8 KHz
Minimum impedance	85 Ω
Common to All	
Absolute maximum applied voltage relative to 0V	-9 V to 14 V

7	U, C, Not used, Not used
8	U\, C\, Not used, Not used
AB Servo (3), FD Servo(4), FR Servo (5), SC Servo (12)	
Type	EIA 485 differential receivers
Maximum input frequency	512 kHz
Line loading	1 unit load
Line termination components	120 Ω (switchable)
Working common mode range	-7 V to +12 V
SC SC (15)	
Type	Differential voltage
Maximum Signal level	1.25 V peak to peak (sin with regard to sinref and cos with regard to cosref)
Maximum input frequency	See Table 4-12
Maximum applied differential voltage and common mode voltage range	±4 V
EnDat (8), SSI (10), BiSS (13)	
Not used	
Resolver (14)	
Not used	
Common to All	
Absolute maximum applied voltage relative to 0V	-9 V to 14 V

9	V, D, Not used, Not used
10	V\, D\, Not used, Not used
AB Servo (3), FD Servo(4), FR Servo (5), SC Servo (12)	
Type	EIA 485 differential receivers
Maximum input frequency	512 kHz
Line loading	1 unit load
Line termination components	120 Ω (switchable)
Working common mode range	-7 V to +12 V
SC SC (15)	
Type	Differential voltage
Maximum Signal level	1.25 V peak to peak (sin with regard to sinref and cos with regard to cosref)
Maximum input frequency	See Table 4-12
Maximum applied differential voltage and common mode voltage range	±4 V
EnDat (8), SSI (10), BiSS (13)	
Not used	
Resolver (14)	
Not used	
Common to All	
Absolute maximum applied voltage relative to 0V	-9 V to 14 V

11	W, Clock, Not used, Not used
12	W\, Clock\, Not used, Not used
AB Servo (3), FD Servo(4), FR Servo (5), SC Servo (12)	
Type	EIA 485 differential receivers
Maximum input frequency	512 kHz
Line loading	1 unit load
Line termination components	120 Ω (switchable)
Working common mode range	-7 V to +12 V
SC EnDat (9), SC SSI (11)	
Type	Differential voltage
Maximum Signal level	1.25 V peak to peak (sin with regard to sinref and cos with regard to cosref)
Maximum input frequency	See Table 4-12
Maximum applied differential voltage and common mode voltage range	±4 V
EnDat (8), SSI (10), BiSS (13)	
Not used	
Resolver (14)	
Not used	
Common to All	
Absolute maximum applied voltage relative to 0V	-9 V to 14 V

Safety information	Product information	Mechanical installation	Electrical installation	Getting started	Basic parameters	Running the motor	Optimization	Drive communication	NV Media Card Operation	Onboard PLC	Advanced parameters	Diagnostics	UL information
--------------------	---------------------	-------------------------	--------------------------------	-----------------	------------------	-------------------	--------------	---------------------	-------------------------	-------------	---------------------	-------------	----------------

Common to all Feedback types

13	Feedback device supply
Supply voltage	5.15 V ± 2 %, 8 V ± 5 % or 15 V ± 5 %
Maximum output current	300 mA for 5 V and 8 V 200 mA for 15 V
The voltage on Terminal 13 is controlled by Pr 03.036 . The default for this parameter is 5 V (0) but this can be set to 8 V (1) or 15 V (2). Setting the encoder voltage too high for the encoder could result in damage to the feedback device. The termination resistors should be disabled if the outputs from the encoder are higher than 5 V.	

14	0V Common
-----------	------------------

15	Motor thermistor input
Thermistor type is selected in <i>P1 Thermistor Type</i> (03.118).	

Sincos encoder resolution

The sine wave frequency can be up to 500 kHz but the resolution is reduced at high frequency. Table 4-12 shows the number of bits of interpolated information at different frequencies and with different voltage levels at the drive encoder port. The total resolution in bits per revolution is the ELPR plus the number of bits of interpolated information. Although it is possible to obtain 11 bits of interpolation information, the nominal design value is 10 bits.

Table 4-12 Feedback resolution based on frequency and voltage level

Volt/Freq	1 kHz	5 kHz	50 kHz	100 kHz	200 kHz	500 kHz
1.2	11	11	10	10	9	8
1.0	11	11	10	9	9	7
0.8	10	10	10	9	8	7
0.6	10	10	9	9	8	7
0.4	9	9	9	8	7	6

4.5 Safe Torque Off (STO)

The *Unidrive M700 / M701* has a single channel STO, whereas the *Unidrive M702* has a dual channel STO.

The Safe Torque Off function provides a means for preventing the drive from generating torque in the motor, with a very high level of integrity. It is suitable for incorporation into a safety system for a machine. It is also suitable for use as a conventional drive enable input.

The safety function is active when the STO input is in the logic-low state as specified in the control terminal specification. The function is defined according to EN 61800-5-2 and IEC 61800-5-2 as follows. (In these standards a drive offering safety-related functions is referred to as a PDS(SR)):

'Power that can cause rotation (or motion in the case of a linear motor) is not applied to the motor. The PDS(SR) will not provide energy to the motor which can generate torque (or force in the case of a linear motor)'

This safety function corresponds to an uncontrolled stop in accordance with stop category 0 of IEC 60204-1.

The Safe Torque Off function makes use of the special property of an inverter drive with an induction motor, which is that torque cannot be generated without the continuous correct active behaviour of the inverter circuit. All credible faults in the inverter power circuit cause a loss of torque generation.

The Safe Torque Off function is fail-safe, so when the Safe Torque Off input is disconnected the drive will not operate the motor, even if a combination of components within the drive has failed. Most component failures are revealed by the drive failing to operate. Safe Torque Off is also independent of the drive firmware. This meets the requirements of the following standards, for the prevention of operation of the motor.

Machinery Applications

The Safe Torque Off function has been independently assessed by Notified Body, TÜV Rheinland for use as a safety component of a machine:

Prevention of unintended motor operation: The safety function "Safe Torque Off" can be used in applications up to Cat 4, PL e according to EN ISO 13849-1, SIL 3 according to EN 61800-5-2/ EN 62061/ IEC 61508 and in lift applications according to EN 81-1 and EN81-2.

Type examination certificate number	Date of issue	Models
01.205/5270.01/14	11-11-2014	M700, M701, M702

This certificate is available for download from the TÜV Rheinland website at: <http://www.tuv.com>

Safety information	Product information	Mechanical installation	Electrical installation	Getting started	Basic parameters	Running the motor	Optimization	Drive communication	NV Media Card Operation	Onboard PLC	Advanced parameters	Diagnostics	UL information
--------------------	---------------------	-------------------------	-------------------------	-----------------	------------------	-------------------	--------------	---------------------	-------------------------	-------------	---------------------	-------------	----------------

Safety Parameters as verified by TÜV Rheinland:

According to IEC 61508-1 to 07 / EN 61800-5-2 / EN 62061

Type	Value	Percentage of SIL 3 allowance
Proof test interval	20 years	
High demand or a continuous mode of operation		
PFH (1/h)	4.21×10^{-11} 1/h	<1 %
Low demand mode of operation (not EN 61800-5-2)		
PFDavg	3.68×10^{-6}	< 1 %

According to EN ISO 13849-1

Type	Value	Classification
Category	4	
Performance Level (PL)	e	
MTTF _D (STO1)	>2500 years	High
MTTF _D (STO2)	>2500 years	High
MTTFD (Single channel STO)	>2500 years	High
DC _{avg}	≥99 %	High
Mission time	20 years	

NOTE

Logic levels comply with IEC 61131-2:2007 for type 1 digital inputs rated at 24 V. Maximum level for logic low to achieve SIL3 and PL e 5 V and 0.5 mA.

Lift (Elevator) Applications

The Safe Torque Off function has been independently assessed for use as a safety component in lift (elevator) applications by Notified Body, TÜV Nord:

The Unidrive M drives series with Safe Torque Off (STO) function if applied according to the "Conditions of application" fulfil the safety requirements of the standards EN81-1, EN81-2, EN 81-50 and EN60664-1 and are in conformity with all relevant requirements of the Directive 95/16/EC.

Certificate of Conformity number	Date of issue	Models
44799 13196202	04-08-2015	M700, M701, M702

The Safe Torque Off function can be used to eliminate electro-mechanical contactors, including special safety contactors, which would otherwise be required for safety applications.

For further information contact the supplier of the drive.

UL Approval

The Safe Torque Off function has been independently assessed by Underwriters Laboratories (UL). The on-line certification (yellow card) reference is: FSPC.E171230.

Safety Parameters as verified by UL:

According to IEC 61508-1 to 7

Type	Value
Safety Rating	SIL 3
SFF	> 99 %
PFH (1/h)	4.43×10^{-10} 1/h (<1 % of SIL 3 allowance)
HFT	1
Beta Factor	2 %
CFF	Not applicable

According to EN ISO 13849-1

Type	Value
Category	4
Performance Level (PL)	e
MTTF _D	2574 years
Diagnostic coverage	High
CCF	65

Two-channel Safe Torque Off

Models M700 and M701 have a single channel STO, whereas the M702 has dual channel STO.

The dual channel STO has two fully independent channels.

Each input meets the requirements of the standards as defined above.

If either or both inputs are set at a logic low state, there are no single faults in the drive which can permit the motor to be driven.

It is not necessary to use both channels to meet the requirements of the standards. The purpose of the two channels is to allow connection to machine safety systems where two channels are required, and to facilitate protection against wiring faults.

For example, if each channel is connected to a safety-related digital output of a safety related controller, computer or PLC, then on detection of a fault in one output the drive can still be disabled safely through the other output.

Under these conditions, there are no single wiring faults which can cause a loss of the safety function, i.e. inadvertent enabling of the drive.

In the event that the two-channel operation is not required, the two inputs can be connected together to form a single Safe Torque Off input.

One-channel Safe Torque Off (Including Two-channel Safe Torque off with the inputs connected together.)

In a single channel Safe Torque Off application there are no single faults in the drive which can permit the motor to be driven. Therefore it is not necessary to have a second channel to interrupt the power connection, nor a fault detection circuit.

It is important to note that a single short-circuit from the Safe Torque Off input to a DC supply of > 5 V could cause the drive to be enabled.

This might occur through a fault in the wiring. This can be excluded according to EN ISO 13849-2 by the use of protected wiring. The wiring can be protected by either of the following methods:

- By placing the wiring in a segregated cable duct or other enclosure.

or

- By providing the wiring with a grounded (0V of the Drive) shield in a positive-logic grounded control circuit. The shield is provided to avoid a hazard from an electrical fault. It may be grounded by any convenient method; no special EMC precautions are required.

Note on response time of Safe Torque Off, and use with safety controllers with self-testing outputs:

Safe Torque Off has been designed to have a response time of greater than 1 ms so that it is compatible with safety controllers whose outputs are subject to a dynamic test with a pulse width not exceeding 1 ms.

Note on the use of servo motors, other permanent-magnet motors, reluctance motors and salient-pole induction motors:

When the drive is disabled through Safe Torque Off, a possible (although highly unlikely) failure mode is for two power devices in the inverter circuit to conduct incorrectly.

Safety information	Product information	Mechanical installation	Electrical installation	Getting started	Basic parameters	Running the motor	Optimization	Drive communication	NV Media Card Operation	Onboard PLC	Advanced parameters	Diagnostics	UL information
--------------------	---------------------	-------------------------	--------------------------------	-----------------	------------------	-------------------	--------------	---------------------	-------------------------	-------------	---------------------	-------------	----------------

This fault cannot produce a steady rotating torque in any AC motor. It produces no torque in a conventional induction motor with a cage rotor. If the rotor has permanent magnets and/or saliency, then a transient alignment torque may occur. The motor may briefly try to rotate by up to 180° electrical, for a permanent magnet motor, or 90° electrical, for a salient pole induction motor or reluctance motor. This possible failure mode must be allowed for in the machine design.

**WARNING**

The design of safety-related control systems must only be done by personnel with the required training and experience. The Safe Torque Off function will only ensure the safety of a machine if it is correctly incorporated into a complete safety system. The system must be subject to a risk assessment to confirm that the residual risk of an unsafe event is at an acceptable level for the application.

**WARNING**

Safe Torque Off inhibits the operation of the drive, this includes inhibiting braking. If the drive is required to provide both braking and Safe Torque Off in the same operation (e.g. for emergency stop) then a safety timer relay or similar device must be used to ensure that the drive is disabled a suitable time after braking. The braking function in the drive is provided by an electronic circuit which is not fail-safe. If braking is a safety requirement, it must be supplemented by an independent fail-safe braking mechanism.

**WARNING**

Safe Torque Off does not provide electrical isolation. The supply to the drive must be disconnected by an approved isolation device before gaining access to power connections.

**WARNING**

It is essential to observe the maximum permitted voltage of 5 V for a safe low (disabled) state of Safe Torque Off. The connections to the drive must be arranged so that voltage drops in the 0 V wiring cannot exceed this value under any loading condition. It is strongly recommended that the Safe Torque Off circuit be provided with a dedicated 0 V conductor which should be connected to terminal 30 at the drive.

Safe Torque Off over-ride

The drive does not provide any facility to over-ride the Safe Torque Off function, for example for maintenance purposes.

5 Getting started

This chapter introduces the user interfaces, menu structure and security levels of the drive.

5.1 Understanding the display

The keypad can only be mounted on the drive.

5.1.1 KI-Keypad

The KI-Keypad display consists of two rows of text. The upper row shows the drive status or the menu and parameter number currently being viewed. The lower row of the display line shows the parameter value or the specific trip type. The last two characters on the first row may display special indications. If more than one of these indications is active then the indications are prioritized as shown in Table 5-2.

When the drive is powered up the lower row will show the power up parameter defined by *Parameter Displayed At Power-Up* (11.022).

Figure 5-1 KI-Keypad

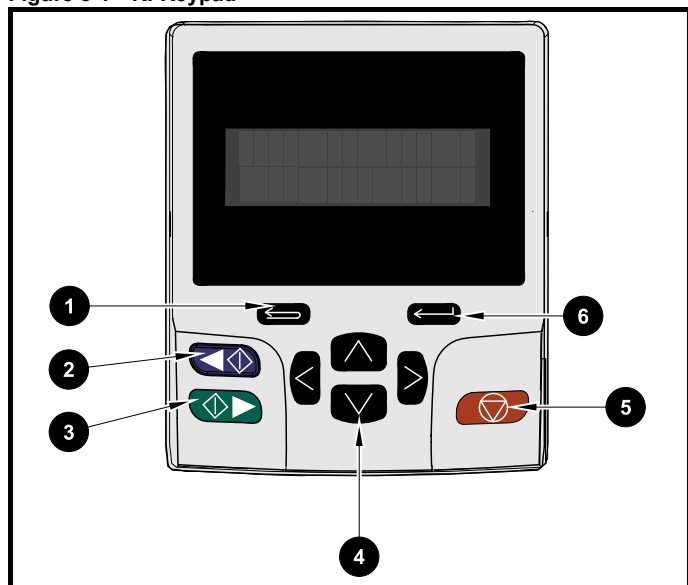

1. Escape button
2. Start reverse (Auxiliary button)
3. Start forward
4. Navigation keys (x4)
5. Stop / Reset (red) button
6. Enter button

NOTE









The red stop  button is also used to reset the drive.

The parameter value is correctly displayed in the lower row of the keypad display, see table below.

Table 5-1 Keypad display formats

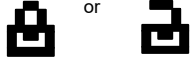
Display formats	Value
IP Address	127.000.000.000
MAC Address	01ABCDEF2345
Time	12:34:56
Date	31-12-11 or 12-31-11
Version number	01.02.02.00
Character	ABCD
32 bit number with decimal point	21474836.47
16 bit binary number	0100001011100101

Table 5-2 Active action icon

Active action icon	Description	Priority
	Alarm active	
	Keypad real-time clock battery low	
	Accessing non-volatile media card	
	Drive security active and locked or unlocked	
	Motor map 2 active	
	User program running	
	Keypad reference active	

5.2 Keypad operation

5.2.1 Control buttons

The keypad consists of:

- Navigation Keys - Used to navigate the parameter structure and change parameter values.
- Enter / Mode button - Used to toggle between parameter edit and view mode.
- Escape / Exit button - Used to exit from parameter edit or view mode. In parameter edit mode, if parameter values are edited and the exit button pressed the parameter value will be restored to the value it had on entry to edit mode.
- Start forward button - Use to provide a 'Run' command if keypad mode is selected.
- Start reverse button - Used to control the drive if keypad mode is selected and the reverse button is activated. If *Enable Auxiliary Key* (06.013) = 1, then the keypad reference is toggled between run forward and run reverse each time the button is pressed. If *Enable Auxiliary Key* (06.013) = 2, then the button functions as a run reverse key.
- Stop / Reset button - Used to reset the drive. In keypad mode can be used for 'Stop'.

NOTE

Low battery voltage is indicated by  low battery symbol on the keypad display.

Figure 5-2 overleaf shows an example on moving between menus and editing parameters.

Figure 5-2 Display modes

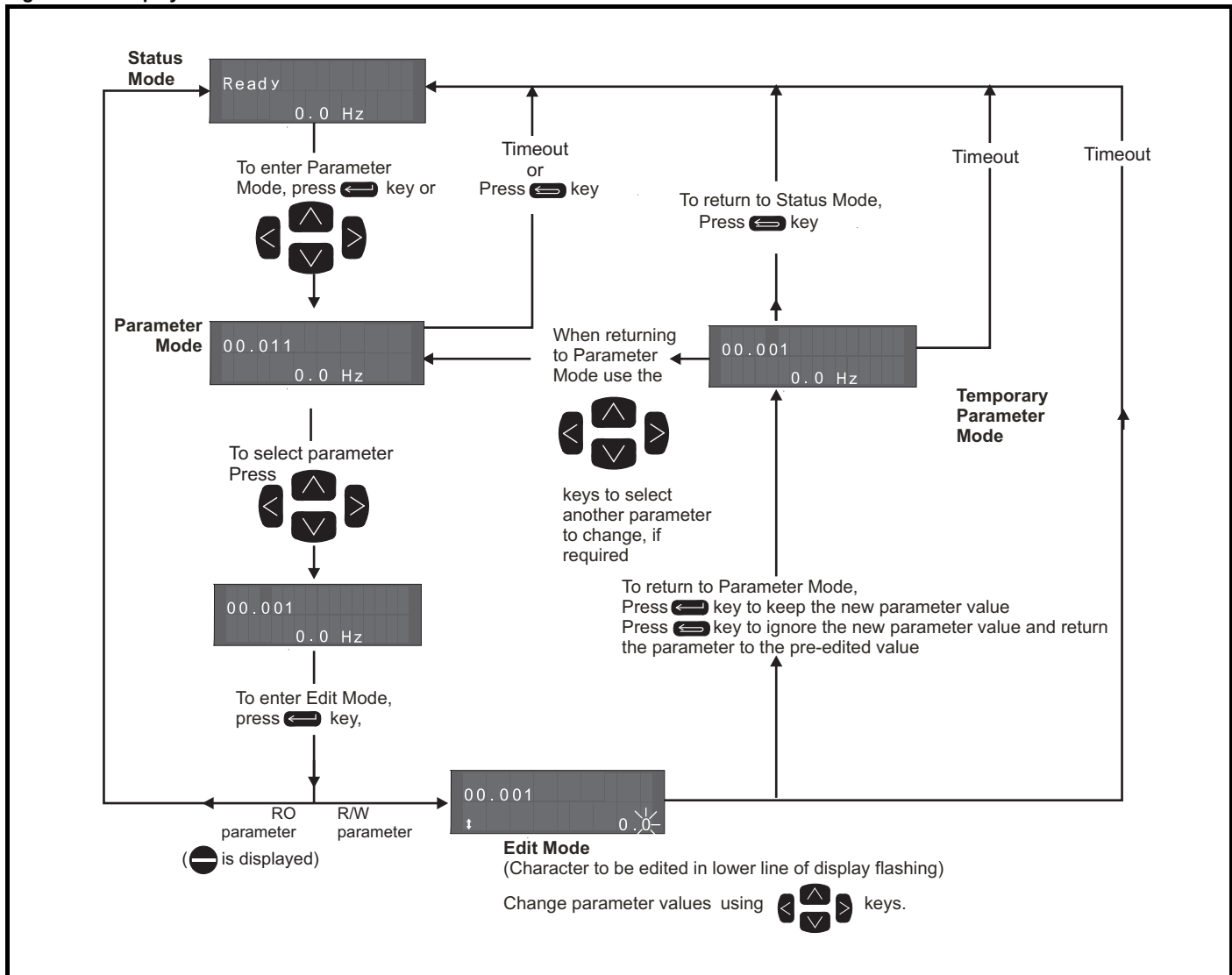

NOTE

The navigation keys can only be used to move between menus if Pr 00.049 has been set to show 'All Menus'. Refer to section 5.9 *Parameter access level and security* on page 46.

5.2.2 Quick access mode

The quick access mode allows direct access to any parameter without scrolling through menus and parameters.

To enter the quick access mode, press and hold the Enter button on the keypad while in 'parameter mode'.

Figure 5-3 Quick access mode



5.2.3 Keypad shortcuts

In 'parameter mode':

- If the up and down keypad buttons are pressed together, then the keypad display will jump to the start of the parameter menu being viewed, i.e. Pr 05.005 being viewed, when the above buttons pressed together will jump to Pr 05.000.
- If the left and right keypad buttons are pressed together, then the keypad display will jump to the last viewed parameter in Menu 0.

In 'parameter edit mode':

- If the up and down keypad buttons are pressed together, then the parameter value of the parameter being edited will be set to 0.
- If the left and right keypad buttons are pressed together, the least significant digit (furthest right) will be selected on the keypad display for editing.

Figure 5-4 Mode examples

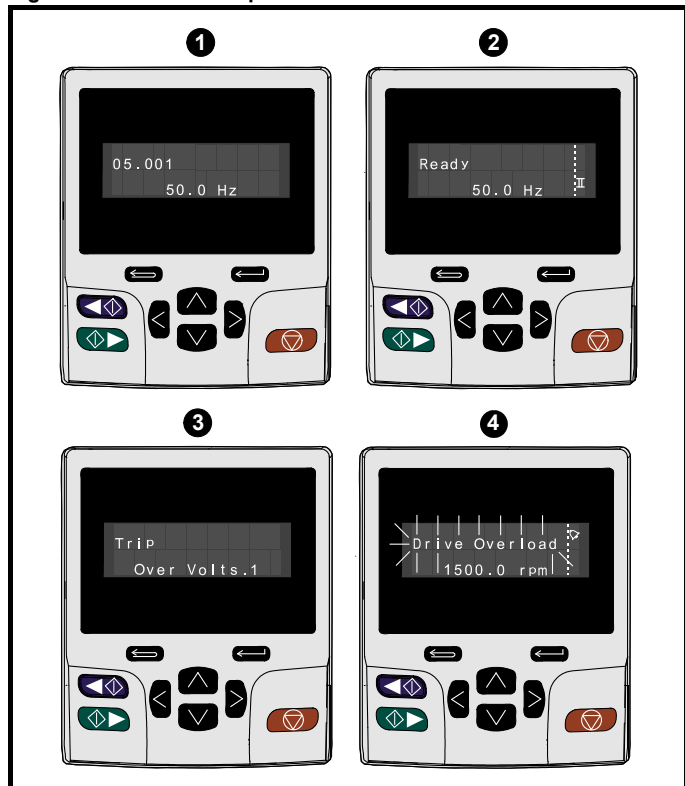

1. Parameter view mode: Read write or Read only

2. Status mode: Drive OK status

If the drive is ok and the parameters are not being edited or viewed, the upper row of the display will show one of the following:

- 'Inhibit', 'Ready' or 'Run'.

3. Status mode: Trip status

When the drive is in trip condition, the upper row of the display will indicate that the drive has tripped and the lower row of the display will show the trip code. For further information regarding trip codes, refer to Table 13-4 *Trip indications* on page 247.

4. Status mode: Alarm status

During an 'alarm' condition the upper row of the display flashes between the drive status (Inhibit, Ready or Run, depending on what is displayed) and the alarm.

WARNING Do not change parameter values without careful consideration; incorrect values may cause damage or a safety hazard.

NOTE

When changing the values of parameters, make a note of the new values in case they need to be entered again.

NOTE

For new parameter-values to apply after the line power supply to the drive is interrupted, new values must be saved. Refer to section 5.7 *Saving parameters* on page 45.

5.3 Menu structure

The drive parameter structure consists of menus and parameters.

The drive initially powers up so that only Menu 0 can be viewed. The up and down arrow buttons are used to navigate between parameters and once Pr 00.049 has been set to 'All Menus' the left and right buttons are used to navigate between menus. For further information, refer to section 5.9 *Parameter access level and security* on page 46.

Figure 5-5 Parameter navigation

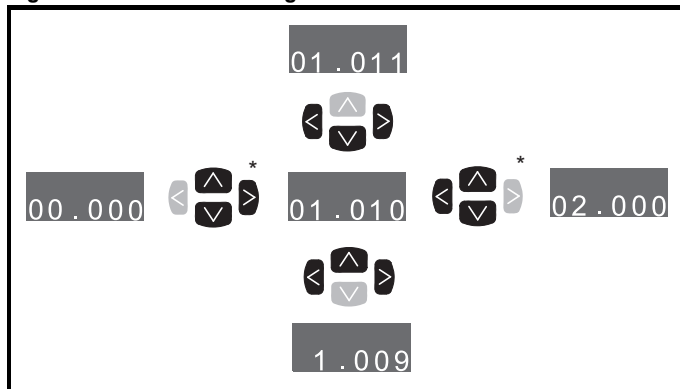

* Can only be used to move between menus if all menus have been enabled (Pr 00.049). Refer to section 5.9 *Parameter access level and security* on page 46.

The menus and parameters roll over in both directions.

i.e. if the last parameter is displayed, a further press will cause the display to rollover and show the first parameter.

When changing between menus the drive remembers which parameter was last viewed in a particular menu and thus displays that parameter.

Figure 5-6 Menu structure

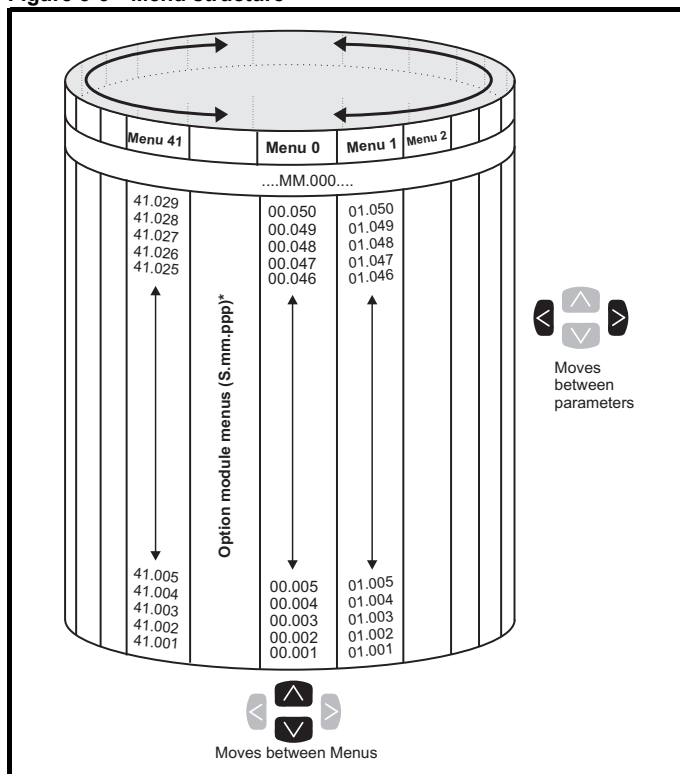

* The option module menu (S.mm.ppp) are only displayed if option modules are installed. Where S signifies the option module slot number and the mm.ppp signifies the menu and the parameter number of the option module's internal menus and parameter.

Safety information	Product information	Mechanical installation	Electrical installation	Getting started	Basic parameters	Running the motor	Optimization	Drive communication	NV Media Card Operation	Onboard PLC	Advanced parameters	Diagnostics	UL information
--------------------	---------------------	-------------------------	-------------------------	-----------------	------------------	-------------------	--------------	---------------------	-------------------------	-------------	---------------------	-------------	----------------

5.4 Menu 0

Menu 0 is used to bring together various commonly used parameters for basic easy set up of the drive. The parameters displayed in Menu 0 can be configured in Menu 22.

Appropriate parameters are copied from the advanced menus into Menu 0 and thus exist in both locations.

For further information, refer to Chapter 6 *Basic parameters* on page 49.

Figure 5-7 Menu 0 copying

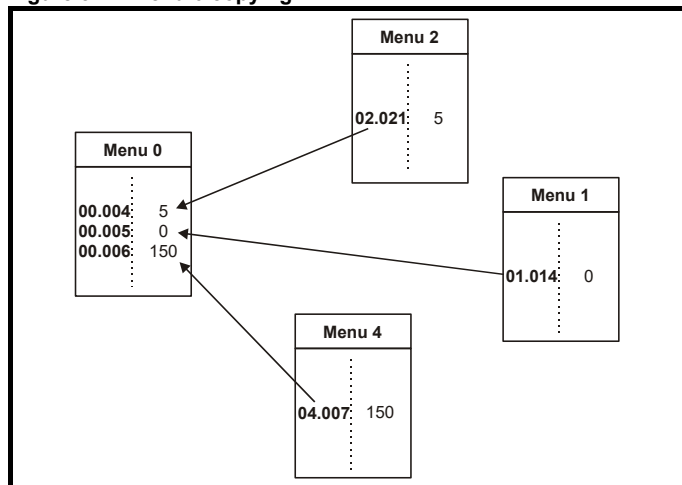

5.5 Advanced menus

The advanced menus consist of groups or parameters appropriate to a specific function or feature of the drive. Menus 0 to 41 can be viewed on the KI-Keypad.

The option module menus (S.mm.ppp) are only displayed (except for *Unidrive M700 / M702 4.mm.ppp*) if option modules are installed. Where S signifies the option module slot number and the mm.ppp signifies the menu and parameter number of the option module's internal menu and parameter.

On *Unidrive M700 / M702*, menu 4.00.xxx is the same as menu 24.xxx.

Table 5-3 Advanced menu descriptions

Menu	Description
0	Commonly used basic set up parameters for quick / easy programming
1	Frequency / Speed reference
2	Ramps
3	Frequency slaving, speed feedback and speed control
4	Torque and current control
5	Motor control
6	Sequencer and clock
7	Analog I/O
8	Digital I/O
9	Programmable logic, motorized pot, binary sum, timers and scope
10	Status and trips
11	Drive set-up and identification, serial communications
12	Threshold detectors and variable selectors
13	Standard motion control
14	User PID controller
15	Option module slot 1 set-up menu
16	Option module slot 2 set-up menu
17	Option module slot 3 set-up menu
18	General option module application menu 1
19	General option module application menu 2
20	General option module application menu 3
21	Second motor parameters
22	Menu 0 set-up
23	Not allocated
24	Ethernet module (slot 4) set-up menu*
25	Option module slot 1 application parameters
26	Option module slot 2 application parameters
27	Option module slot 3 application parameters
28	Option module slot 4 application parameters
29	Reserved menu
30	Onboard user programming application menu
31-41	Advanced motion controller set-up parameters
Slot 1	Slot 1 option menus**
Slot 2	Slot 2 option menus**
Slot 3	Slot 3 option menus**
Slot 4	Slot 4 option menus**

* Only displayed on *Unidrive M700 / M702*.

** Only displayed when the option modules are installed.

Safety information	Product information	Mechanical installation	Electrical installation	Getting started	Basic parameters	Running the motor	Optimization	Drive communication	NV Media Card Operation	Onboard PLC	Advanced parameters	Diagnostics	UL information
--------------------	---------------------	-------------------------	-------------------------	-----------------	------------------	-------------------	--------------	---------------------	-------------------------	-------------	---------------------	-------------	----------------

5.5.1 KI-Keypad set-up menu

To enter the keypad set-up menu press and hold the escape  button on the keypad from status mode. All the keypad parameters are saved to the keypad non-volatile memory when exiting from the keypad set-up menu.



To exit from the keypad set-up menu press the escape  or  or  button. Below are the keypad set-up parameters.

Table 5-4 KI-Keypad set-up parameters

Parameters		Range	Type
Keypad.00	Language*	Classic English (0) English (1) German (2) French (3) Italian (4) Spanish (5) Chinese (6)	RW
Keypad.01	Show Units	Off (0), On (1)	RW
Keypad.02	Backlight Level	0 to 100 %	RW
Keypad.03	Keypad Date	01.01.10 to 31.12.99	RO
Keypad.04	Keypad Time	00:00:00 to 23:59:59	RO
Keypad.05	Show Raw Text Parameter Values	Off (0), On (1)	RW
Keypad.06	Software Version	00.00.00.00 to 99.99.99.99	RO
Keypad.07	Language version	00.00.00.00 to 99.99.99.99	RO
Keypad.08	Font version	0 to 1000	RO
Keypad.09	Show menu names	Off or on	RW

* The languages available will depend on the keypad software version.

NOTE

It is not possible to access the keypad parameters via any communications channel.

5.5.2 Alarm indications

An alarm is an indication given on the display by alternating the alarm string with the drive status string on the upper row and showing the alarm symbol in the last character in the upper row. Alarms strings are not displayed when a parameter is being edited, but the user will still see the alarm character on the upper row.

Table 5-5 Alarm indications

Alarm string	Description
Brake Resistor	Brake resistor overload. <i>Braking Resistor Thermal Accumulator</i> (10.039) in the drive has reached 75.0 % of the value at which the drive will trip.
Motor Overload	<i>Motor Protection Accumulator</i> (04.019) in the drive has reached 75.0 % of the value at which the drive will trip and the load on the drive is > 100 %.
Ind Overload	Regen inductor overload. <i>Inductor Protection Accumulator</i> (04.019) in the drive has reached 75.0 % of the value at which the drive will trip and the load on the drive is > 100 %.
Drive Overload	Drive over temperature. <i>Percentage Of Drive Thermal Trip Level</i> (07.036) in the drive is greater than 90 %.
Auto Tune	The autotune procedure has been initialized and an autotune in progress.
Limit Switch	Limit switch active. Indicates that a limit switch is active and that is causing the motor to be stopped.

5.5.3 Display messages

The following tables indicate the various possible mnemonics which can be displayed by the drive and their meaning.

Table 5-6 Status indications

Upper row string	Description	Drive output stage
Inhibit	The drive is inhibited and cannot be run. The Safe Torque Off signal is not applied to Safe Torque Off terminals or Pr 06.015 is set to 0. The other conditions that can prevent the drive from enabling are shown as bits in <i>Enable Conditions</i> (06.010)	Disabled
Ready	The drive is ready to run. The drive enable is active, but the drive inverter is not active because the final drive run is not active	Disabled
Stop	The drive is stopped / holding zero speed.	Enabled
Run	The drive is active and running	Enabled
Scan	The drive is enabled in Regen mode and is trying to synchronize to the supply	Enabled
Supply Loss	Supply loss condition has been detected	Enabled
Deceleration	The motor is being decelerated to zero speed / frequency because the final drive run has been deactivated.	Enabled
dc injection	The drive is applying dc injection braking	Enabled
Position	Positioning / position control is active during an orientation stop	Enabled
Trip	The drive has tripped and no longer controlling the motor. The trip code appears in the lower display.	Disabled
Active	The Regen unit is enabled and synchronized to the supply	Enabled
Under Voltage	The drive is in the under voltage state either in low voltage or high voltage mode.	Disabled
Heat	The motor pre-heat function is active	Enabled
Phasing	The drive is performing a 'phasing test on enable'	Enabled

Safety information	Product information	Mechanical installation	Electrical installation	Getting started	Basic parameters	Running the motor	Optimization	Drive communication	NV Media Card Operation	Onboard PLC	Advanced parameters	Diagnostics	UL information
--------------------	---------------------	-------------------------	-------------------------	-----------------	------------------	-------------------	--------------	---------------------	-------------------------	-------------	---------------------	-------------	----------------

Table 5-7 Option module and NV media card and other status indications at power-up

First row string	Second row string	Status
Booting	Parameters	Parameters are being loaded
Drive parameters are being loaded from a NV Media Card		
Booting	User Program	User program being loaded
User program is being loaded from a NV Media Card to the drive		
Booting	Option Program	User program being loaded
User program is being loaded from a NV Media Card to the option module in slot X		
Writing To	NV Card	Data being written to NV Media Card
Data is being written to a NV Media Card to ensure that its copy of the drive parameters is correct because the drive is in Auto or Boot mode		
Waiting For	Power System	Waiting for power stage
The drive is waiting for the processor in the power stage to respond after power-up		
Waiting For	Options	Waiting for an option module
The drive is waiting for the options modules to respond after power-up		
Uploading From	Options	Loading parameter database
At power-up it may be necessary to update the parameter database held by the drive because an option module has changed or because an applications module has requested changes to the parameter structure. This may involve data transfer between the drive an option modules. During this period 'Uploading From Options' is displayed		

5.6 Changing the operating mode



Changing the operating mode returns all parameters to their default value, including the motor parameters. *User security status* (00.049) and *User security code* (00.034) are not affected by this procedure).

Procedure

Use the following procedure only if a different operating mode is required:

1. Ensure the drive is not enabled, i.e. terminal 31 on *Unidrive M700 / M701* and terminal 11 & 13 on *Unidrive M702* is open or Pr **06.015** is Off (0)
2. Enter either of the following values in Pr **mm.000**, as appropriate:
1253 (50 Hz AC supply frequency)
1254 (60 Hz AC supply frequency)

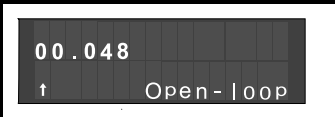
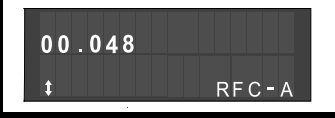
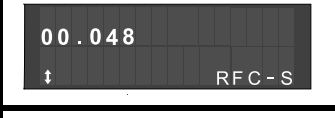
3. Change the setting of Pr **00.048** as follows:

Pr 00.048 setting	Operating mode
	1 Open-loop
	2 RFC-A
	3 RFC-S
	4 Regen

The figures in the second column apply when the communications interface is used.

4. Either:

- Press the red  reset button
- Toggle the reset digital input
- Carry out a drive reset through the communications interface by setting Pr **10.038** to 100.

NOTE

Entering 1253 or 1254 in Pr **mm.000** will only load defaults if the setting of Pr **00.048** has been changed.

5.7 Saving parameters

When changing a parameter in Menu 0, the new value is saved when pressing the  Enter button to return to parameter view mode from parameter edit mode.

If parameters have been changed in the advanced menus, then the change will not be saved automatically. A save function must be carried out.

Procedure

1. Select 'Save Parameters' in Pr **mm.000** (alternatively enter a value of 1001 in Pr **mm.000**)
2. Either:
 - Press the red  reset button
 - Toggle the reset digital input, or
 - Carry out a drive reset through the communications interface by setting Pr **10.038** to 100

5.8 Restoring parameter defaults

Restoring parameter defaults by this method saves the default values in the drives memory. *User security status* (00.049) and *User security code* (00.034) are not affected by this procedure).

Procedure

1. Ensure the drive is not enabled, i.e. terminal 31 on *Unidrive M700 / M701* and terminal 11 & 13 on *Unidrive M702* is open or Pr **06.015** is Off (0)
2. Select 'Reset 50 Hz Defs' or 'Reset 60 Hz Defs' in Pr **mm.000**. (alternatively, enter 1233 (50 Hz settings) or 1244 (60 Hz settings) in Pr **mm.000**).
3. Either:
 - Press the red  reset button
 - Toggle the reset digital input
 - Carry out a drive reset through the communications interface by setting Pr **10.038** to 100

Safety information	Product information	Mechanical installation	Electrical installation	Getting started	Basic parameters	Running the motor	Optimization	Drive communication	NV Media Card Operation	Onboard PLC	Advanced parameters	Diagnostics	UL information
--------------------	---------------------	-------------------------	-------------------------	-----------------	------------------	-------------------	--------------	---------------------	-------------------------	-------------	---------------------	-------------	----------------

5.9 Parameter access level and security

The parameter access level determines whether the user has access to Menu 0 only or to all the advanced menus (Menus 1 to 41) in addition to Menu 0.

The User Security determines whether the access to the user is read only or read write.

Both the User Security and Parameter Access Level can operate independently of each other as shown in Table 5-8.

Table 5-8 Parameter access level and security

User security status (11.044)	Access level	User security	Menu 0 status	Advanced menu status
0	Menu 0	Open	RW	Not visible
		Closed	RO	Not visible
1	All Menus	Open	RW	RW
		Closed	RO	RO
2	Read-only Menu 0	Open	RO	Not visible
		Closed	RO	Not visible
3	Read-only	Open	RO	RO
		Closed	RO	RO
4	Status only	Open	Not visible	Not visible
		Closed	Not visible	Not visible
5	No access	Open	Not visible	Not visible
		Closed	Not visible	Not visible

The default settings of the drive are Parameter Access Level Menu 0 and user Security Open i.e. read / write access to Menu 0 with the advanced menus not visible.

5.9.1 User Security Level / Access Level

The drive provides a number of different levels of security that can be set by the user via *User Security Status* (11.044); these are shown below.

User Security Status (Pr 11.044)	Description
Menu 0 (0)	All writable parameters are available to be edited but only parameters in Menu 0 are visible
All menus (1)	All parameters are visible and all writable parameters are available to be edited
Read-only Menu 0 (2)	Access is limited to Menu 0 parameters only. All parameters are read-only
Read-only (3)	All parameters are read-only however all menus and parameters are visible
Status only (4)	The keypad remains in status mode and no parameters can be viewed or edited
No access (5)	The keypad remains in status mode and no parameters can be viewed or edited. Drive parameters cannot be accessed via a comms/ fieldbus interface in the drive or any option module

5.9.2 Changing the User Security Level /Access Level

The security level is determined by the setting of Pr **00.049** or Pr **11.044**. The Security Level can be changed through the keypad even if the User Security Code has been set.

5.9.3 User Security Code

The User Security Code, when set, prevents write access to any of the parameters in any menu.

Setting User Security Code

Enter a value between 1 and 2147483647 in Pr **00.034** and press the

 button; the security code has now been set to this value. In order

to activate the security, the Security level must be set to desired level in Pr **00.049**. When the drive is reset, the security code will have been

activated and the drive returns to Menu 0 and the  symbol is displayed in the right hand corner of the keypad display. The value of Pr **00.034** will return to 0 in order to hide the security code.

Unlocking User Security Code

Select a parameter that need to be edited and press the  button, the upper display will now show 'Security Code'. Use the arrow buttons

to set the security code and press the  button. With the correct security code entered, the display will revert to the parameter selected in edit mode.

If an incorrect security code is entered, the following message 'Incorrect security code' is displayed, then the display will revert to parameter view mode.

Disabling User Security

Unlock the previously set security code as detailed above. Set Pr **00.034**

to 0 and press the  button. The User Security has now been disabled, and will not have to be unlocked each time the drive is powered up to allow read / write access to the parameters.

5.10 Displaying parameters with non-default values only

By selecting 'Show non-default' in Pr **mm.000** (Alternatively, enter 12000 in Pr **mm.000**), the only parameters that will be visible to the user will be those containing a non-default value. This function does not require a drive reset to become active. In order to deactivate this function, return to Pr **mm.000** and select 'No action' (alternatively enter a value of 0). Please note that this function can be affected by the access level enabled, refer to section 5.9 *Parameter access level and security* on page 46 for further information regarding access level.

5.11 Displaying destination parameters only

By selecting 'Destinations' in Pr **mm.000** (Alternatively enter 12001 in Pr **mm.000**), the only parameters that will be visible to the user will be destination parameters. This function does not require a drive reset to become active. In order to deactivate this function, return to Pr **mm.000** and select 'No action' (alternatively enter a value of 0).

Please note that this function can be affected by the access level enabled, refer to section 5.9 *Parameter access level and security* on page 46 for further information regarding access level.

5.12 Communications

The *Unidrive M700 / M702* drives offer Ethernet fieldbus communications and the *Unidrive M701* drive offers a 2 wire EIA 485 interface. This enables the drive set-up, operation and monitoring to be carried out with a PC or controller if required.

Safety information	Product information	Mechanical installation	Electrical installation	Getting started	Basic parameters	Running the motor	Optimization	Drive communication	NV Media Card Operation	Onboard PLC	Advanced parameters	Diagnostics	UL information
--------------------	---------------------	-------------------------	-------------------------	-----------------	------------------	-------------------	--------------	---------------------	-------------------------	-------------	---------------------	-------------	----------------

5.12.1 Unidrive M700 / M702 - Ethernet communications

The drive offers fieldbus communications via Ethernet, this enables the drive set-up, operation and monitoring to be carried out with a PC or controller. The drive provides two RJ45 connections with an Ethernet switch for easy network creation. The Ethernet option provides support for the following protocols:

- Modbus TCP
- EtherNet/IP or Profinet IO
- Web pages*
- Email**
- Synchronization with IEEE1588
- RTMoE

*Basic Web page functionality only

**Features have not been implemented but will be available soon.

In addition to two RJ45 connectors, each port provides a status LED for diagnostic / information purposes.

LED status	Description
Off	Ethernet connection not detected
Solid green	Ethernet connection detected but no data
Flashing green	Ethernet connection detected and data flow

Figure 5-8 Location of the Ethernet ports

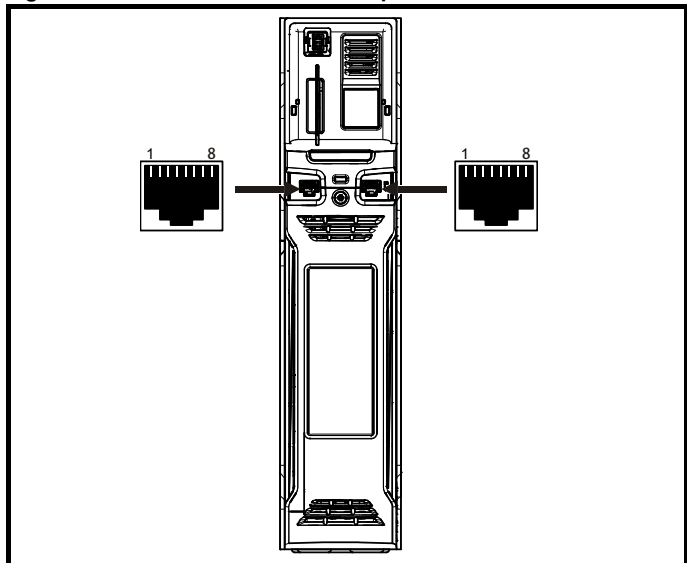

NOTE

The shell of the RJ45 connector is isolated from the 0V of the drive control terminals but it is connected to ground.

NOTE

Modbus TCP/IP has a maximum number of 4 client connections. Refer to Pr 4.15.006 (Maximum Connections) in the *Parameter Reference Guide*. The default value of Pr 4.15.006 is 2 client connections, but the maximum number of client connections is 10.

Recommended cable

It is recommended that a minimum specification of CAT5e is used in new installations. If the existing cabling is used this may limit the maximum data rate depending on the cable ratings. In noisy environments the use of STP cable will offer additional noise immunity.

Maximum network lengths

The main restriction imposed on the Ethernet cabling is the length of a single segment of the cable, for Copper - UTP/STP CAT 5 cable type, maximum trunk cable length should be limited to 100 m. If distances greater than this are required it may be possible to extend the network with additional switches.

Ethernet set-up parameters

This section covers the parameters necessary to establish an Ethernet connection to the drive.

Table 5-9 Key to parameter table coding

RW	Read / Write	ND	No default value
RO	Read only	NC	Not copied
Num	Number parameter	PT	Protected parameter
Bit	Bit parameter	RA	Rating dependant
Txt	Text string	US	User save
Bin	Binary parameter	PS	Power-down save
Fl	Filtered	DE	Destination
IP	IP Address	Mac	Mac Address
Date	Date parameter	Time	Time parameter
Chr	Character parameter		

4.00.007 {24.007}	Reset								
RW	Bit							US	
⇅		Off (0) or On (1)				⇒	Off (0)		

Changes to the Ethernet set-up parameters will not take effect until a *Reset* (4.00.007) has been performed.

4.00.010 {24.010}	Active IP Address								
RO	IP							US	
⇅		128.000.000.000 to 127.255.255.255				⇒			

This parameter displays the Active IP Address. The Active IP Address can also be viewed in Pr 00.037.

4.02.005	DHCP Enable								
RW	Bit							US	
⇅		Off (0) or On (1)				⇒	On (1)		

If *DHCP Enable* (4.02.005) is set to On (1), the IP address is acquired from the DHCP server and written to *IP Address* (4.02.006).

NOTE

When using manual / static IP address configuration, ensure *Subnet Mask* (4.02.007) and *Default Gateway* (4.02.008) should also be set manually.

NOTE

If *Protocol Mode Select* (4.02.018) is set to Profinet (2) and the IP address is assigned to a Profinet Controller, *DHCP Enable* (4.02.005) will be ignored and set to Off (0) on initialisation.

4.02.006	IP Address								
RW	IP							US	
⇅		000.000.000.000 to 255.255.255.255				⇒	192.168.001.100		

This parameter controls and displays the IP address of the drive. If *DHCP Enable* (4.02.005) is set to On (1) this parameter will become read-only.

Safety information	Product information	Mechanical installation	Electrical installation	Getting started	Basic parameters	Running the motor	Optimization	Drive communication	NV Media Card Operation	Onboard PLC	Advanced parameters	Diagnostics	UL information
--------------------	---------------------	-------------------------	-------------------------	-----------------	------------------	-------------------	--------------	---------------------	-------------------------	-------------	---------------------	-------------	----------------

4.02.007 Subnet Mask	
RW	IP
↑	000.000.000.000 to 255.255.255.255
⇒	255.255.255.000

This parameter controls and displays the *Subnet Mask* (4.02.007) of the drive.

4.02.008 Default Gateway	
RW	IP
↑	000.000.000.000 to 255.255.255.255
⇒	192.168.1.254

This parameter controls and displays the *Default Gateway* (4.02.008) of the drive.

PC Tools support

The discovery protocol feature, which is supported by the Unidrive M PC tools, is able to discover the drives that are connected to a PC, independent of above parameter settings.

5.12.2 Unidrive M701 - EIA 485 Serial communications

The EIA 485 option provides two parallel RJ45 connectors allowing easy daisy chaining. The drive only supports Modbus RTU protocol.

The serial communications port of the drive is a RJ45 socket, which is isolated from the power stage and the other control terminals (see section 4.2 *Communication connections* on page 23 for connection and isolation details).

The communications port applies a 2 unit load to the communications network.

USB/EIA 232 to EIA 485 Communications

An external USB/EIA 232 hardware interface such as a PC cannot be used directly with the 2-wire EIA 485 interface of the drive. Therefore a suitable converter is required.

Suitable USB to EIA 485 and EIA 232 to EIA 485 isolated converters are available from Control Techniques as follows:

- CT USB Comms cable (CT Part No. 4500-0096)
- CT EIA 232 Comms cable (CT Part No. 4500-0087)

NOTE

When using the CT EIA 232 Comms cable the available baud rate is limited to 19.2 k baud.

When using one of the above converters or any other suitable converter with the drive, it is recommended that no terminating resistors be connected on the network. It may be necessary to 'link out' the terminating resistor within the converter depending on which type is used. The information on how to link out the terminating resistor will normally be contained in the user information supplied with the converter.

Serial communications set-up parameters

The following parameters need to be set according to the system requirements.

Serial communications set-up parameters		
<i>Serial Mode</i> (11.024) {00.035}	8 2 NP (0), 8 1 NP (1), 8 1 EP (2), 8 1 OP (3), 8 2 NP M (4), 8 1 NP M (5), 8 1 EP M (6), 8 1 OP M (7), 7 2 NP (8), 7 1 NP (9), 7 1 EP (10), 7 1 OP (11), 7 2 NP M (12), 7 1 NP M (13), 7 1 EP M (14), 7 1 OP M (15)	The drive only supports the Modbus RTU protocol and is always a slave. This parameter defines the supported data formats used by the EIA 485 comms port (if installed) on the drive. This parameter can be changed via the drive keypad, via a option module or via the comms interface itself.
<i>Serial Baud Rate</i> (11.025) {00.036}	300 (0), 600 (1), 1200 (2), 2400 (3), 4800 (4), 9600 (5), 19200 (6), 38400 (7), 57600(8), 76800(9), 115200 (10)	This parameter can be changed via the drive keypad, via a option module or via the comms interface itself. If it is changed via the comms interface, the response to the command uses the original baud rate. The master should wait at least 20 ms before sending a new message using the new baud rate.
<i>Serial Address</i> (11.023) {00.037}	1 to 247	This parameter defines the serial address and an addresses between 1 and 247 are permitted.

Safety information	Product information	Mechanical installation	Electrical installation	Getting started	Basic parameters	Running the motor	Optimization	Drive communication	NV Media Card Operation	Onboard PLC	Advanced parameters	Diagnostics	UL information
--------------------	---------------------	-------------------------	-------------------------	-----------------	-------------------------	-------------------	--------------	---------------------	-------------------------	-------------	---------------------	-------------	----------------

6 Basic parameters

Menu 0 is used to bring together various commonly used parameters for basic easy set up of the drive. All the parameters in Menu 0 appear in other menus in the drive (denoted by {...}). Menu 22 can be used to configure the parameters in Menu 0.

6.1 Parameter ranges and variable minimum / maximums

Some parameters in the drive have a variable range with a variable minimum and a variable maximum value which is dependent on one of the following:

- The settings of other parameters
- The drive rating
- The drive mode
- Combination of any of the above

For more information, refer to section 12.1 *Parameter ranges and Variable minimum/maximums* on page 148

6.2 Menu 0: Basic parameters

Parameter	Range			Default			Type					
	OL	RFC-A	RFC-S	OL	RFC-A	RFC-S						
00.001 Minimum Reference Clamp {01.007}	VM_NEGATIVE_REF_CLAMP1 Hz / rpm			0.0 Hz	0.0 rpm		RW	Num				US
00.002 Maximum Reference Clamp {01.006}	VM_POSITIVE_REF_CLAMP1 Hz / rpm			50 Hz default: 50.0 Hz 60 Hz default: 60.0 Hz	50 Hz default: 1500.0 rpm 60 Hz default: 1800.0 rpm	3000.0 rpm	RW	Num				US
00.003 Acceleration Rate 1 {02.011}	0.0 to VM_ACCEL_RATE s/100 Hz	0.000 to VM_ACCEL_RATE s/1000 rpm		5.0 s/100 Hz	2.000 s/1000 rpm	0.200 s/1000 rpm	RW	Num				US
00.004 Deceleration Rate 1 {02.021}	0.0 to VM_ACCEL_RATE s/100 Hz	0.000 to VM_ACCEL_RATE s/1000 rpm		10.0 s/100 Hz	2.000 s/1000 rpm	0.200 s/1000 rpm	RW	Num				US
00.005 Reference Selector {01.014}	A1 A2 (0), A1 Preset (1), A2 Preset (2), Preset (3), Keypad (4), Precision (5), Keypad Ref (6)			A1 A2 (0) / Preset (3)***			RW	Txt				US
00.006 Symmetrical Current Limit {04.007}	0.0 to VM_MOTOR1_CURRENT_LIMIT %			165.0 % ¹	175.0 % ²		RW	Num		RA		US
00.007 Open-loop Control Mode {05.014}	Ur S (0), Ur (1), Fixed (2), Ur Auto (3), Ur I (4), Square (5)			Ur I (4)			RW	Txt				US
Speed Controller Proportional Gain Kp1 {03.010}	0.0000 to 200.000 s/rad			0.0300 s/rad 0.0100 s/rad			RW	Num				US
00.008 Low Frequency Voltage Boost {05.015}	0.0 to 25.0 %			3.0 %			RW	Num				US
Speed Controller Integral Gain Ki1 {03.011}	0.00 to 655.35 s ² /rad			0.10 s ² /rad 1.00 s ² /rad			RW	Num				US
00.009 Dynamic V to F Select {05.013}	Off (0) or On (1)			Off (0)			RW	Bit				US
Speed Controller Differential Feedback Gain Kd 1 {03.012}	0.00000 to 0.65535 1/rad			0.00000 1/rad			RW	Num				US
00.010 Motor Rpm {05.004}	±180000 rpm						RO	Bit				US
Speed Feedback {03.002}	VM_SPEED rpm						RO	Num	ND	NC	PT	FI
00.011 Output Frequency {05.001}	VM_SPEED_FREQ_REF Hz	± 2000.0 Hz					RO	Num	ND	NC	PT	FI
P1 Position {03.029}	0 to 65535						RO	Num	ND	NC	PT	FI
00.012 Current Magnitude {04.001}	0.000 to VM_DRIVE_CURRENT_UNIPOLAR A						RO	Bit	ND	NC	PT	FI
00.013 Torque Producing Current {04.002}	VM_DRIVE_CURRENT A						RO	Bit	ND	NC	PT	FI
00.014 Torque Mode Selector {04.011}	0 or 1	0 to 5		0			RW	Num				US
00.015 Ramp Mode {02.004}	Fast (0), Standard (1), Std boost (2)	Fast (0), Standard (1)		Standard (1)			RW	Txt				US
00.016 Ramp Enable {02.002}	Off (0) or On (1)			On (1)			RW	Bit				US
00.017 Digital Input 6 Destination**** {08.026}	00.000 to 59.999			06.031			RW	Num	DE		PT	US
Current Reference Filter 1 Time Constant {04.012}	0.0 to 25.0 ms			0.0 ms			RW	Num				US
00.018 P1 Thermistor Fault Detection {03.123}	None (0), Temperature (1), Temp or Short (2)			None (0)			RW	Txt				US
00.019 Analog Input 2 Mode**** {07.011}	4-20 mA Low (-4), 20-4 mA Low (-3), 4-20 mA Hold (-2), 20-4 mA Hold (-1), 0-20 mA (0), 20-0 mA (1), 4-20 mA Trip (2), 20-4 mA Trip (3), 4-20 mA (4), 20-4 mA (5), Volt (6)			Volt (6)			RW	Txt				US
00.020 Analog Input 2 Destination**** {07.014}	00.000 to 59.999			01.037			RW	Num	DE		PT	US
00.021 Analog Input 3 Mode**** {07.015}	M700, M701: Volt (6), Therm Short Cct (7), Thermistor (8), Therm No Trip (9) M702: Therm Short Cct (7), Thermistor (8), Therm No Trip (9), Disabled (10)			M700, M701: Volt (6) M702: Disabled (10)			RW	Txt				US
00.022 Bipolar Reference Enable {01.010}	Off (0) or On (1)			Off (0)			RW	Bit				US
00.023 Jog Reference {01.005}	0.0 to 400.0 Hz	0.0 to 4000.0 rpm		0.0			RW	Num				US
00.024 Preset Reference 1 {01.021}	VM_SPEED_FREQ_REF			0.0			RW	Num				US
00.025 Preset Reference 2 {01.022}	VM_SPEED_FREQ_REF			0.0			RW	Num				US
00.026 Preset Reference 3 {01.023}	VM_SPEED_FREQ_REF Hz			0.0			RW	Num				US
Overspeed Threshold {03.008}	0 to 40000 rpm			0.0			RW	Num				US

Safety information	Product information	Mechanical installation	Electrical installation	Getting started	Basic parameters	Running the motor	Optimization	Drive communication	NV Media Card Operation	Onboard PLC	Advanced parameters	Diagnostics	UL information
--------------------	---------------------	-------------------------	-------------------------	-----------------	------------------	-------------------	--------------	---------------------	-------------------------	-------------	---------------------	-------------	----------------

Parameter	Range			Default			Type						
	OL	RFC-A	RFC-S	OL	RFC-A	RFC-S							
00.027 Preset Reference 4 {01.024}	VM_SPEED FREQ_REF Hz			0.0			RW	Num				US	
	P1 Rotary Lines Per Revolution {03.034}			1 to 100000					1024	4096	RW	Num	US
00.028 Enable Auxiliary Key {06.013}	Disabled (0), Forward/Reverse (1), Run Reverse (2)			Disabled (0)			RW	Txt				US	
00.029 NV Media Card File Previously Loaded {11.036}	0 to 999						RO	Num		NC	PT		
00.030 Parameter Cloning {11.042}	None (0), Read (1), Program (2), Auto (3), Boot (4)			None (0)			RW	Txt		NC		US	
00.031 Drive Rated Voltage {11.033}	200 V (0), 400 V (1), 575 V (2), 690 V (3)						RO	Txt	ND	NC	PT		
00.032 Maximum Heavy Duty Rating {11.032}	0.000 to 99999.999 A						RO	Num	ND	NC	PT		
00.033	Catch A Spinning Motor {06.009}	Disable (0), Enable (1), Fwd Only (2), Rev Only (3)			Disable (0)			RW	Txt				US
	Rated Speed Optimisation Select {05.016}	Disabled (0), Classic Slow (1), Classic Fast (2), Combined (3), VARs Only (4), Voltage Only (5)			Disabled (0)			RW	Txt				US
00.034 User Security Code {11.030}	0 to 2 ³¹ -1			0			RW	Num	ND	NC	PT	US	
00.035 Serial Mode* {11.024}	8 2 NP (0), 8 1 NP (1), 8 1 EP (2), 8 1 OP (3), 8 2 NP M (4), 8 1 NP M (5), 8 1 EP M (6), 8 1 OP M (7), 7 2 NP (8), 7 1 NP (9), 7 1 EP (10), 7 1 OP (11), 7 2 NP M (12), 7 1 NP M (13), 7 1 EP M (14), 7 1 OP M (15)			8 2 NP (0)			RW	Txt				US	
00.036 Serial Baud Rate* {11.025}	300 (0), 600 (1), 1200 (2), 2400 (3), 4800 (4), 9600 (5), 19200 (6), 38400 (7), 57600 (8), 76800 (9), 115200 (10)			19200 (6)			RW	Txt				US	
00.037	Serial Address* {11.023}	1 to 247			1			RW	Num				US
	Active IP Address** {24.010}	0.0.0.0 to 255.255.255.255						RO	IP		NC	PT	
00.038 Current Controller Kp Gain {04.013}	0 to 30000			20 150			RW	Num				US	
00.039 Current Controller Ki Gain {04.014}	0 to 30000			40 2000			RW	Num				US	
00.040 Auto-tune {05.012}	0 to 2 0 to 5 0 to 6			0			RW	Num		NC			
00.041 Maximum Switching Frequency {05.018}	2 kHz (0), 3 kHz (1), 4 kHz (2), 6 kHz (3), 8 kHz (4), 12 kHz (5), 16 kHz (6)			3 kHz (1) 6 kHz (3)			RW	Txt		RA		US	
00.042 Number Of Motor Poles {05.011}	Automatic (0) to 480 Poles (240)			Automatic (0) 6 Poles (3)			RW	Num				US	
00.043	Rated Power Factor***** {05.010}	0.000 to 1.000			0.850			RW	Num		RA		US
	Position Feedback Phase Angle {03.025}				0.0 to 359.9 °			RW	Num	ND			US
00.044 Rated Voltage {05.009}	0 to VM_AC_VOLTAGE_SET V			200 V drive: 230 V 50 Hz default 400V drive: 400 V 60 Hz default 400V drive: 460 V 575 V drive: 575 V 690 V drive: 690 V			RW	Num		RA		US	
00.045 Rated Speed {05.008}	0 to 35940 rpm 0.00 to 33000.00 rpm			50 Hz default: 1500 rpm 60 Hz default: 1800rpm 50 Hz default: 1450.00 rpm 60 Hz default: 1750.00 rpm 3000.00 rpm			RW	Num				US	
00.046 Rated Current {05.007}	0.000 to VM_RATED_CURRENT A			Maximum Heavy Duty Rating (11.032)			RW	Num		RA		US	
00.047	Rated Frequency {05.006}	0.0 to 599.0 Hz 0.0 to 550.0 Hz			50Hz: 50.0 60Hz: 60.0			RW	Num				US
	Volts per 1000 rpm {05.033}				0 to 10000 V / 1000 rpm 98 V / 1000 rpm			RW	Num				US
00.048 User Drive Mode {11.031}	Open-loop (1), RFC-A (2), RFC-S (3), Regen (4)			Open-loop (1) RFC-A (2) RFC-S (3)			RW	Txt	ND	NC	PT		
00.049 User Security Status {11.044}	Menu 0 (0), All Menus (1), Read-only Menu 0 (2), Read-only (3), Status Only (4), No Access (5)			Menu 0 (0)			RW	Txt	ND		PT		
00.050 Software Version {11.029}	0 to 999999999						RO	Num	ND	NC	PT		
00.051 Action On Trip Detection {10.037}	0 to 31			0			RW	Bin				US	
00.052 Reset Serial Communications* {11.020}	Off (0) or On (1)			Off (0)			RW	Bit	ND	NC			
00.053 Motor Thermal Time Constant 1 {04.015}	1.0 to 3000.0 s			89.0 s			RW	Num				US	

* Only applicable to Unidrive M701.

*** Only applicable to Unidrive M702.

***** Following a rotating autotune Pr 00.043 {05.010} is continuously written by the drive, calculated from the value of Stator Inductance (Pr 05.025). To manually enter a value into Pr 00.043 {05.010}, Pr 05.025 will need to be set to 0. Please refer to the description of Pr 05.010 in the Parameter Reference Guide for further details.

** Only applicable to Unidrive M700 / M702.

**** Only applicable to Unidrive M700 / M701.

1 For size 9 and above the default is 141.9 %.

2 For size 9 and above the default is 150.0 %.

RW	Read / Write	RO	Read only	Num	Number parameter	Bit	Bit parameter	Txt	Text string	Bin	Binary parameter	FI	Filtered
ND	No default value	NC	Not copied	PT	Protected parameter	RA	Rating dependent	US	User save	PS	Power-down save	DE	Destination
IP	IP address	Mac	Mac address	Date	Date parameter	Time	Time parameter						

Safety information	Product information	Mechanical installation	Electrical installation	Getting started	Basic parameters	Running the motor	Optimization	Drive communication	NV Media Card Operation	Onboard PLC	Advanced parameters	Diagnostics	UL information
--------------------	---------------------	-------------------------	-------------------------	-----------------	-------------------------	-------------------	--------------	---------------------	-------------------------	-------------	---------------------	-------------	----------------

Figure 6-1 Menu 0 logic diagram (Unidrive M700 / 701)

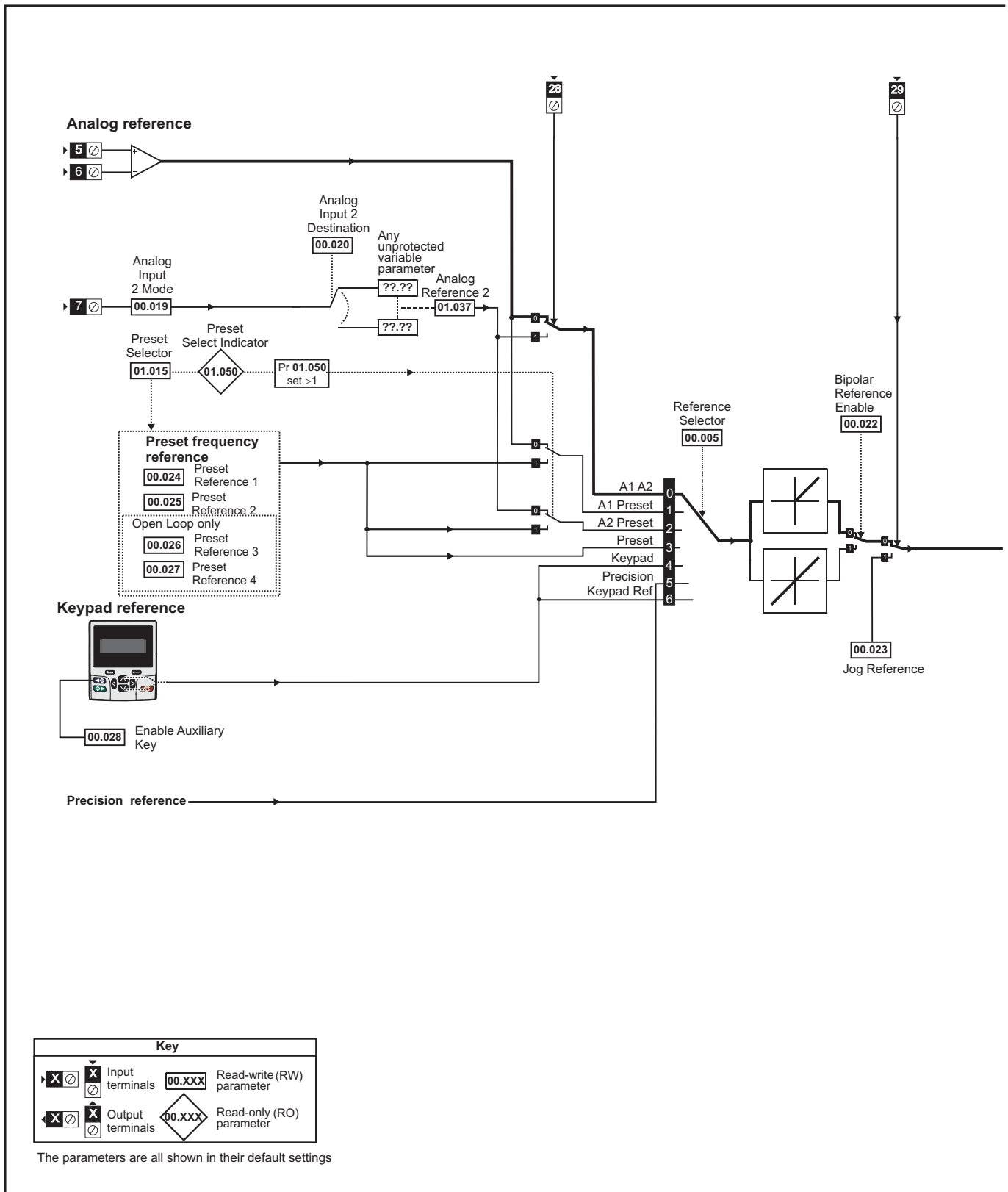

Key			
▶ X	⊗	Input terminals	00.XXX Read-write (RW) parameter
◀ X	⊗	Output terminals	00.XXX Read-only (RO) parameter

The parameters are all shown in their default settings

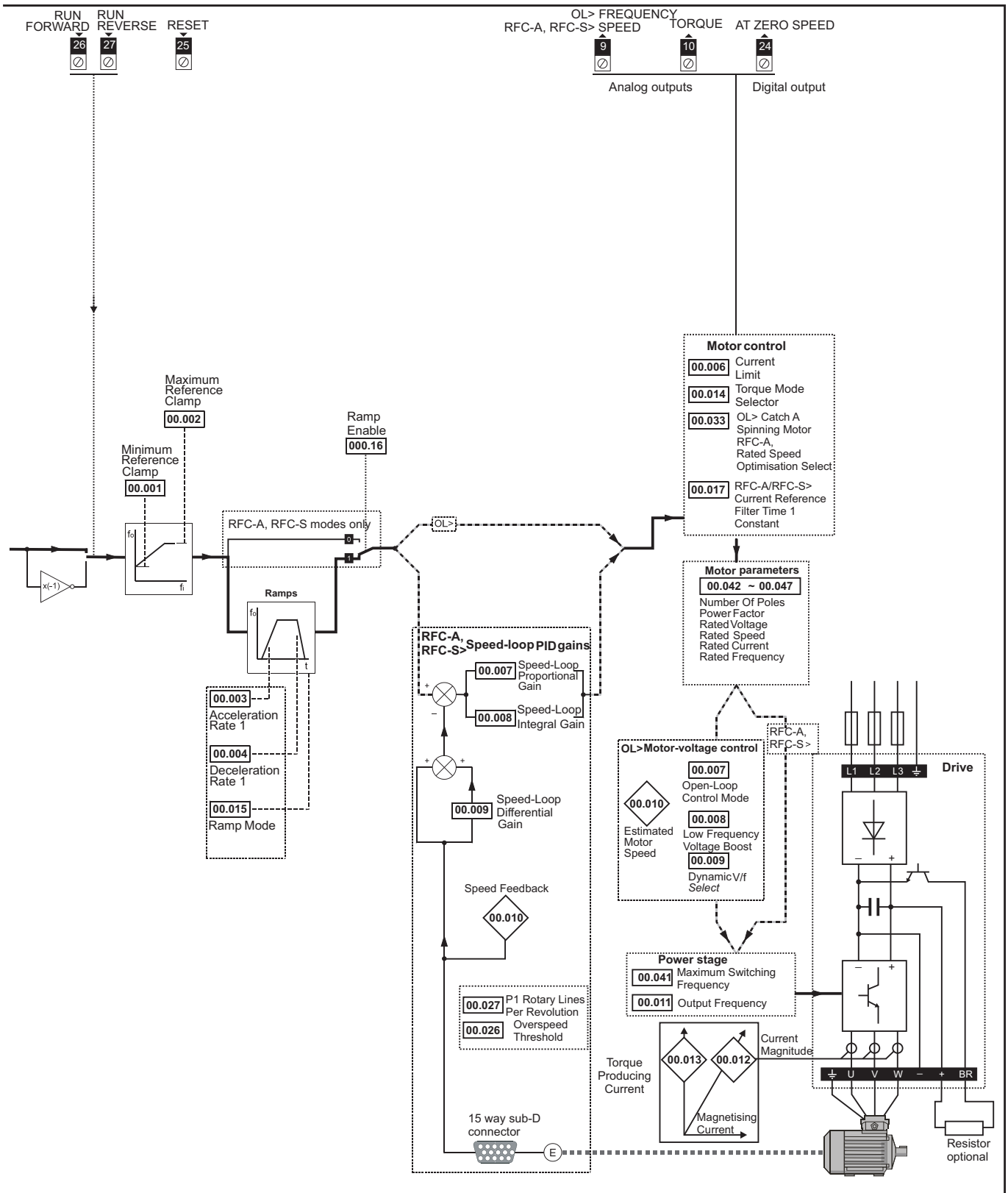
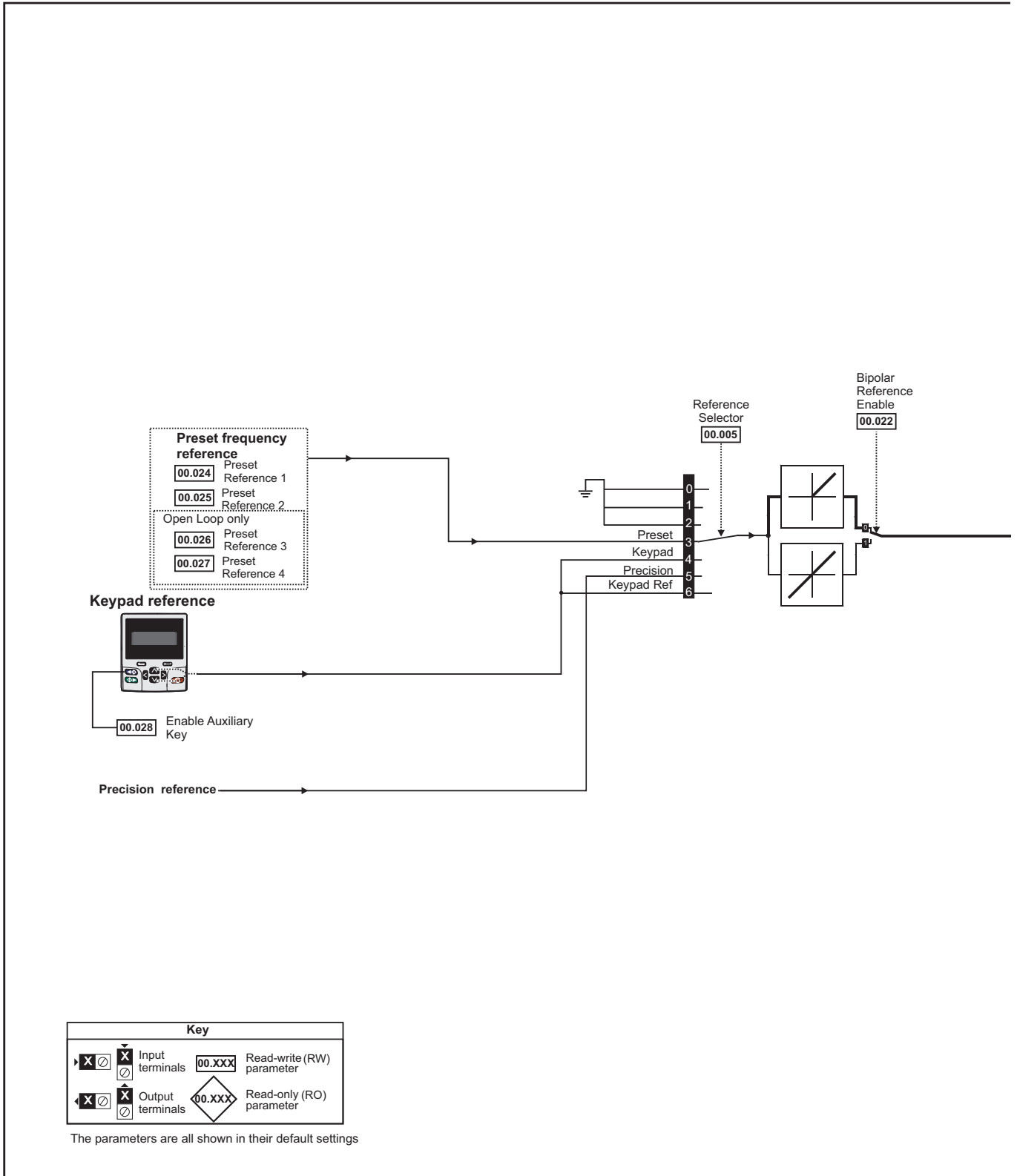
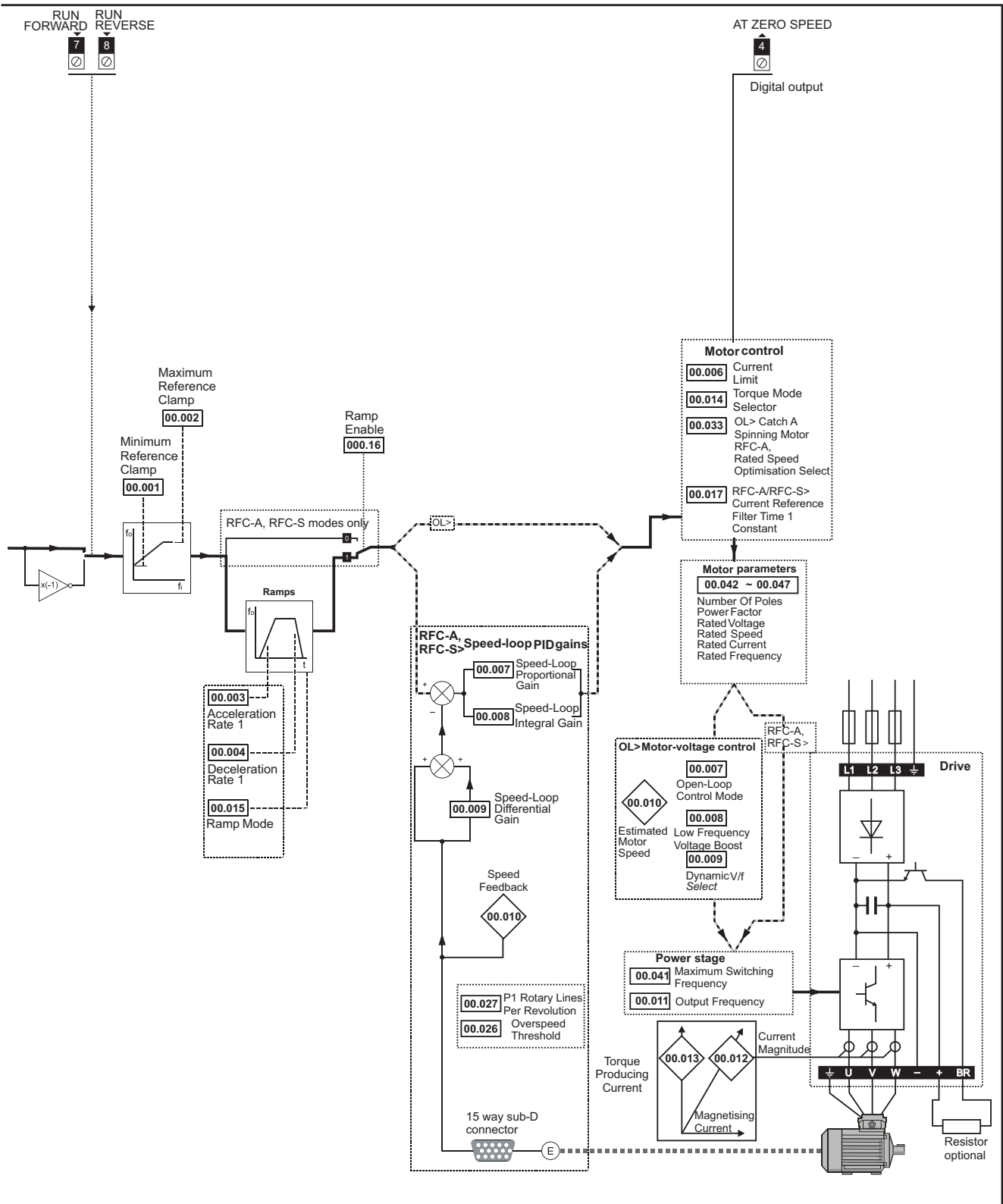

Figure 6-2 Menu 0 logic diagram (Unidrive M702)





Safety information	Product information	Mechanical installation	Electrical installation	Getting started	Basic parameters	Running the motor	Optimization	Drive communication	NV Media Card Operation	Onboard PLC	Advanced parameters	Diagnostics	UL information
--------------------	---------------------	-------------------------	-------------------------	-----------------	------------------	-------------------	--------------	---------------------	-------------------------	-------------	---------------------	-------------	----------------

6.3 Parameter descriptions

6.3.1 Pr mm.000

Pr mm.000 is available in all menus, commonly used functions are provided as text strings in Pr mm.000 shown in Table 6-1. The functions in Table 6-1 can also be selected by entering the appropriate numeric values (as shown in Table 6-2) in Pr mm.000. For example, enter 4001 in Pr mm.000 to store drive parameters on an NV Media Card.

Table 6-1 Commonly used functions in xx.000

Value	Equivalent value	String	Action
0	0	[No Action]	
1001	1	[Save parameters]	Save parameters under all conditions
6001	2	[Load file 1]	Load the drive parameters or user program file from NV Media Card file 001
4001	3	[Save to file 1]	Transfer the drive parameters to parameter file 001
6002	4	[Load file 2]	Load the drive parameters or user program file from NV Media Card file 002
4002	5	[Save to file 2]	Transfer the drive parameters to parameter file 002
6003	6	[Load file 3]	Load the drive parameters or user program file from NV Media Card file 003
4003	7	[Save to file 3]	Transfer the drive parameters to parameter file 003
12000	8	[Show non-default]	Displays parameters that are different from defaults
12001	9	[Destinations]	Displays parameters that are set
1233	10	[Reset 50Hz defs]	Load parameters with standard (50 Hz) defaults
1244	11	[Reset 60Hz defs]	Load parameters with US (60 Hz) defaults
1070	12	[Reset modules]	Reset all option modules
11001	13	[Read enc. NP P1]	Transfer electronic nameplate motor parameters to the drive from the P1 encoder
11051	14	[Read enc. NP P2]	Transfer electronic nameplate motor parameters to the drive from the P2 encoder

Safety information	Product information	Mechanical installation	Electrical installation	Getting started	Basic parameters	Running the motor	Optimization	Drive communication	NV Media Card Operation	Onboard PLC	Advanced parameters	Diagnostics	UL information
--------------------	---------------------	-------------------------	-------------------------	-----------------	-------------------------	-------------------	--------------	---------------------	-------------------------	-------------	---------------------	-------------	----------------

Table 6-2 Functions in Pr mm.000

Value	Action
1000	Save parameters when <i>Under Voltage Active</i> (Pr 10.016) is not active and <i>Low Under Voltage Threshold Select</i> mode (Pr 06.067 = Off) is not active.
1001	Save parameters under all conditions
1070	Reset all option modules
1233	Load standard (50 Hz) defaults
1234	Load standard (50 Hz) defaults to all menus except option module menus (i.e 15 to 20 and 24 to 28)
1244	Load US (60 Hz) defaults
1245	Load US (60 Hz) defaults to all menus except option module menus (i.e 15 to 20 and 24 to 28)
1253	Change drive mode and load standard (50 Hz) defaults
1254	Change drive mode and load US (60 Hz) defaults
1255	Change drive mode and load standard (50 Hz) defaults except for menus 15 to 20 and 24 to 28
1256	Change drive mode and load US (60 Hz) defaults except for menus 15 to 20 and 24 to 28
1299	Reset {Stored HF} trip.
2001*	Create a boot file on a non-volatile media card based on the present drive parameters including all Menu 20 parameters
4yyy*	NV media card: Transfer the drive parameters to parameter file xxx
5yyy*	NV media card: Transfer the onboard user program to onboard user program file xxx
6yyy*	NV media card: Load the drive parameters from parameter file xxx or the onboard user program from onboard user program file xxx
7yyy*	NV media card: Erase file xxx
8yyy*	NV Media card: Compare the data in the drive with file xxx
9555*	NV media card: Clear the warning suppression flag
9666*	NV media card: Set the warning suppression flag
9777*	NV media card: Clear the read-only flag
9888*	NV media card: Set the read-only flag
9999*	NV media card: Erase and format the NV media card
59999	Delete onboard user program
110S1	Transfer electronic nameplate data from an encoder connected to the P1 position feedback interface on the drive or option module in slot 'S' into drive parameters.
110S2	As 110S1, but for the P2 position feedback interface
12000**	Only display parameters that are different from their default value. This action does not require a drive reset.
12001**	Only display parameters that are used to set-up destinations (i.e. DE format bit is 1). This action does not require a drive reset.
15xxx*	Transfer the user program in an option module installed in slot 1 to a non-volatile media card file xxx
16xxx*	Transfer the user program in an option module installed in slot 2 to a non-volatile media card file xxx
17xxx*	Transfer the user program in an option module installed in slot 3 to a non-volatile media card file xxx
18xxx*	Transfer the user program from file xxx in a non-volatile media card to an option module installed in slot 1.
19xxx*	Transfer the user program from file xxx in a non-volatile media card to an option module installed in slot 2.
20xxx*	Transfer the user program from file xxx in a non-volatile media card to an option module installed in slot 3.
21xxx*	Transfer the user program in an option module installed in slot 4 to a non-volatile media card file xxx.
22xxx*	Transfer the user program from file xxx in a non-volatile media card to an option module installed in slot 4.

* See Chapter 10 *NV Media Card Operation* on page 139 for more information on these functions.

** These functions do not require a drive reset to become active. All other functions require a drive reset to initiate the function. Equivalent values and strings are also provided in the table above.

Safety information	Product information	Mechanical installation	Electrical installation	Getting started	Basic parameters	Running the motor	Optimization	Drive communication	NV Media Card Operation	Onboard PLC	Advanced parameters	Diagnostics	UL information
--------------------	---------------------	-------------------------	-------------------------	-----------------	------------------	-------------------	--------------	---------------------	-------------------------	-------------	---------------------	-------------	----------------

6.4 Full descriptions

Table 6-3 Key to parameter table coding

Coding	Attribute
RW	Read/Write: can be written by the user
RO	Read only: can only be read by the user
Bit	1 bit parameter. 'On' or 'Off' on the display
Num	Number: can be uni-polar or bi-polar
Txt	Text: the parameter uses text strings instead of numbers.
Bin	Binary parameter
IP	IP Address parameter
Mac	Mac Address parameter
Date	Date parameter
Time	Time parameter
Chr	Character parameter
FI	Filtered: some parameters which can have rapidly changing values are filtered when displayed on the drive keypad for easy viewing.
DE	Destination: This parameter selects the destination of an input or logic function.
RA	Rating dependent: this parameter is likely to have different values and ranges with drives of different voltage and current ratings. Parameters with this attribute will be transferred to the destination drive by non-volatile storage media when the rating of the destination drive is different from the source drive and the file is a parameter file. However, the values will be transferred if only the current rating is different and the file is a difference from default type file.
ND	No default: The parameter is not modified when defaults are loaded
NC	Not copied: not transferred to or from non-volatile media during copying.
PT	Protected: cannot be used as a destination.
US	User save: parameter saved in drive EEPROM when the user initiates a parameter save.
PS	Power-down save: parameter automatically saved in drive EEPROM when the under volts (UV) state occurs.

6.4.1 Parameter x.00

00.000 {mm.000} Parameter zero				
RW	Num	ND	NC	PT
↕	0 to 65,535			

6.4.2 Speed limits

00.001 {01.007} Minimum Reference Clamp		
RW	Num	US
OL	0.0 Hz	
RFC-A	VM_NEGATIVE_REF_CLAMP1 Hz / rpm	⇒
RFC-S		

(When the drive is jogging, [00.001] has no effect.)

Open-loop

Set Pr **00.001** at the required minimum output frequency of the drive for both directions of rotation. The drive speed reference is scaled between Pr **00.001** and Pr **00.002**. [00.001] is a nominal value; slip compensation may cause the actual frequency to be higher.

RFC-A / RFC-S

Set Pr **00.001** at the required minimum motor speed for both directions of rotation. The drive speed reference is scaled between Pr **00.001** and Pr **00.002**.

00.002 {01.006} Maximum Reference Clamp			
RW	Num	US	
OL	VM_POSITIVE_REF_CLAMP1 Hz / rpm	⇒	
RFC-A			50Hz default: 50.0 Hz 60Hz default: 60.0 Hz
RFC-S			50Hz default: 1500.0 rpm 60Hz default: 1800.0 rpm
		3000.0 rpm	

(The drive has additional over-speed protection).

Open-loop

Set Pr **00.002** at the required maximum output frequency for both directions of rotation. The drive speed reference is scaled between Pr **00.001** and Pr **00.002**. [00.002] is a nominal value; slip compensation may cause the actual frequency to be higher.

RFC-A / RFC-S

Set Pr **00.002** at the required maximum motor speed for both directions of rotation. The drive speed reference is scaled between Pr **00.001** and Pr **00.002**.

For operating at high speeds see section 8.6 *High speed operation* on page 109.

6.4.3 Ramps, speed reference selection, current limit

00.003 {02.011} Acceleration Rate 1		
RW	Num	US
OL	0.0 to VM_ACCEL_RATE s/100 Hz	5.0 s/100 Hz
RFC-A	0.000 to VM_ACCEL_RATE s/1000 rpm	⇒
RFC-S		
		0.200 s/1000 rpm

Set Pr **00.003** at the required rate of acceleration.

Note that larger values produce lower acceleration. The rate applies in both directions of rotation.

00.004 {02.021} Deceleration Rate 1		
RW	Num	US
OL	0.0 to VM_ACCEL_RATE s/100 Hz	10.0 s/100 Hz
RFC-A	0.000 to VM_ACCEL_RATE s/1000 rpm	⇒
RFC-S		
		0.200 s/1000 rpm

Set Pr **00.004** at the required rate of deceleration.

Note that larger values produce lower deceleration. The rate applies in both directions of rotation.

00.005 {01.014} Reference Selector			
RW	Txt	US	
OL	A1 A2 (0)*, A1 Preset (1)*, A2 Preset (2)*, Preset (3), Keypad (4), Precision (5), Keypad Ref (6)	⇒	
RFC-A			M700 / M701: A1 A2 (0) M702: Preset (3)
RFC-S			

* Available on *Unidrive M700 / M701* only.

Safety information	Product information	Mechanical installation	Electrical installation	Getting started	Basic parameters	Running the motor	Optimization	Drive communication	NV Media Card Operation	Onboard PLC	Advanced parameters	Diagnostics	UL information
--------------------	---------------------	-------------------------	-------------------------	-----------------	-------------------------	-------------------	--------------	---------------------	-------------------------	-------------	---------------------	-------------	----------------

Use Pr **00.005** to select the required frequency/speed reference as follows:

Setting	Description
A1 A2*	0 Analog input 1 OR analog input 2 selectable by digital input, terminal 28
A1 Preset*	1 Analog input 1 OR preset frequency/speed
A2 Preset*	2 Analog input 2 OR preset frequency/speed
Preset (3)	3 Pre-set frequency/speed
Keypad (4)	4 Keypad mode
Precision (5)	5 Precision reference
Keypad Ref (6)	6 Keypad Reference

* Available on Unidrive M700 / M701 only.

00.006 {04.007} Symmetrical Current Limit	
RW	Num
OL	165.0 %
RFC-A	0.0 to VM_MOTOR1_CURRENT_LIMIT %
RFC-S	175.0 %

Pr **00.006** limits the maximum output current of the drive (and hence maximum motor torque) to protect the drive and motor from overload. Set Pr **00.006** at the required maximum torque as a percentage of the rated torque of the motor, as follows:

$$[00.006] = \frac{T_R}{T_{RATED}} \times 100 (\%)$$

Where:

T_R Required maximum torque
 T_{RATED} Motor rated torque

Alternatively, set Pr **00.006** at the required maximum active (torque-producing) current as a percentage of the rated active current of the motor, as follows:

$$[00.006] = \frac{I_R}{I_{RATED}} \times 100 (\%)$$

Where:

I_R Required maximum active current
 I_{RATED} Motor rated active current

6.4.4 Voltage boost, (open-loop), Speed-loop PID gains (RFC-A / RFC-S)

00.007 {05.014} Open-loop Control Mode (OL)	
00.007 {03.010} Speed Controller Proportional Gain Kp1 (RFC)	
RW	Txt/Num
OL	Ur S (0), Ur (1), Fixed (2), Ur Auto (3), Ur I (4), Square (5)
RFC-A	0.0300 s/rad
RFC-S	0.0100 s/rad

Open-loop

There are six voltage modes available, which fall into two categories, vector control and fixed boost. For further details, refer to Pr **00.007 {05.014} Open Loop Control Mode** on page 96.

RFC-A/ RFC-S

Pr **00.007 (03.010)** operates in the feed-forward path of the speed-control loop in the drive. See Figure 12-4 on page 166 for a schematic of the speed controller. For information on setting up the speed controller gains, refer to Chapter 8 *Optimization* on page 95.

00.008 {05.015} Low Frequency Voltage Boost (OL)	
00.008 {03.011} Speed Controller Integral Gain Ki1 (RFC)	
RW	Num
OL	0.0 to 25.0 %
RFC-A	0.10 s ² /rad
RFC-S	1.00 s ² /rad

Open-loop

When *Open-loop Control Mode* (00.007) is set at **Fd** or **SrE**, set Pr **00.008 (05.015)** at the required value for the motor to run reliably at low speeds.

Excessive values of Pr **00.008** can cause the motor to be overheated.

RFC-A/ RFC-S

Pr **00.008 (03.011)** operates in the feed-forward path of the speed-control loop in the drive. See Figure 12-4 on page 166 for a schematic of the speed controller. For information on setting up the speed controller gains, refer to Chapter 8 *Optimization* on page 95.

00.009 {05.013} Dynamic V to F Select (OL)	
00.009 {03.012} Speed Controller Differential Feedback Gain Kd 1 (RFC)	
RW	Bit
OL	Off (0) or On (1)
RFC-A	0.00000 to 0.65535 1/rad
RFC-S	0.00000 1/rad

Open-loop

Set Pr **00.009 (05.013)** at 0 when the V/f characteristic applied to the motor is to be fixed. It is then based on the rated voltage and frequency of the motor.

Set Pr **00.009** at 1 when reduced power dissipation is required in the motor when it is lightly loaded. The V/f characteristic is then variable resulting in the motor voltage being proportionally reduced for lower motor currents. Figure 6-3 shows the change in V/f slope when the motor current is reduced.

RFC-A / RFC-S

Pr **00.009 (03.012)** operates in the feedback path of the speed-control loop in the drive. See Figure 12-4 *Menu 3 RFC-A, RFC-S logic diagram* on page 166 for a schematic of the speed controller. For information on setting up the speed controller gains, refer to Chapter 8 *Optimization* on page 95.

Safety information	Product information	Mechanical installation	Electrical installation	Getting started	Basic parameters	Running the motor	Optimization	Drive communication	NV Media Card Operation	Onboard PLC	Advanced parameters	Diagnostics	UL information
--------------------	---------------------	-------------------------	-------------------------	-----------------	------------------	-------------------	--------------	---------------------	-------------------------	-------------	---------------------	-------------	----------------

Figure 6-3 Fixed and variable V/f characteristics

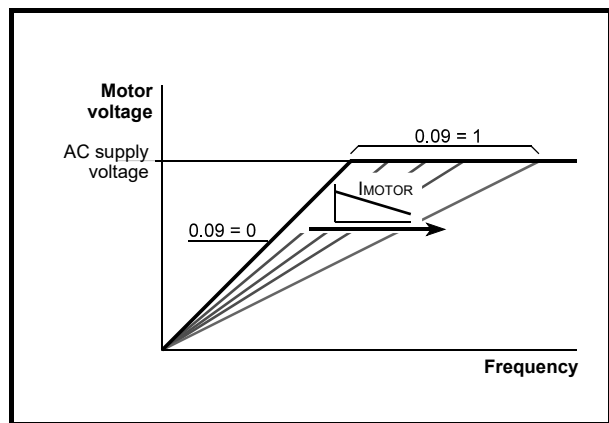

component and a reactive component, which can form a resultant current vector as shown in the following diagram.

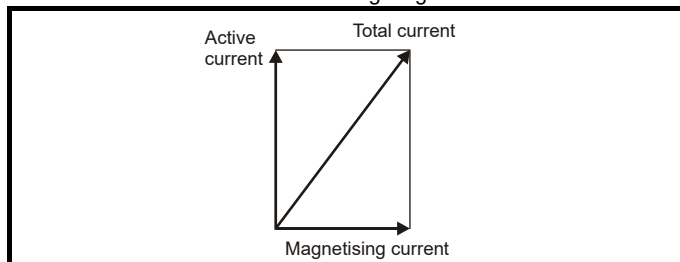

The active current is the torque producing current and the reactive current is the magnetizing or flux-producing current.

6.4.5 Monitoring

00.010 {05.004} Motor Rpm									
RO	Bit								US
OL	↕	±180000 rpm		⇒					

Open-loop

Pr 00.010 (05.004) indicates the value of motor speed that is estimated from the following:

- 02.001 Post Ramp Reference
- 00.042 Number Of Motor Poles

00.010 {03.002} Speed Feedback									
RO	Num	FI			ND	NC	PT		
RFC-A	↕	VM_SPEED rpm		⇒					
RFC-S									

RFC-A / RFC-S

Pr 00.010 (03.002) indicates the value of motor speed that is obtained from the speed feedback.

00.011 {05.001} Output Frequency (OL)									
00.011 {03.029} P1 Position (RFC)									
RO	Num	FI			ND	NC	PT		
OL	↕	VM_SPEED_FREQ_REF Hz		⇒					
RFC-A									
RFC-S	↕	0 to 65535		⇒					

Open-loop and RFC-A

Pr 00.011 displays the frequency at the drive output.

RFC-S

Pr 00.011 displays the position of the encoder in mechanical values of 0 to 65,535. There are 65,536 units to one mechanical revolution.

00.012 {04.001} Current Magnitude									
RO	Bit	FI			ND	NC	PT		
OL		0.000 to		⇒					
RFC-A	↕	VM_DRIVE_CURRENT_UNIPOLAR A		⇒					
RFC-S									

Pr 00.012 displays the rms value of the output current of the drive in each of the three phases. The phase currents consist of an active

00.013 {04.002} Torque Producing Current									
RO	Bit	FI			ND	NC	PT		
OL									
RFC-A	↕	VM_DRIVE_CURRENT A		⇒					
RFC-S									

When the motor is being driven below its rated speed, the torque is proportional to [00.013].

6.4.6 Jog reference, Ramp mode selector, Stop and torque mode selectors

Pr 00.014 is used to select the required control mode of the drive as follows:

00.014 {04.011} Torque Mode Selector									
RW	Num								US
OL	↕	0 or 1		⇒	0				
RFC-A	↕	0 to 5		⇒	0				
RFC-S									

Setting	Open-Loop	RFC-A/S
0	Frequency control	Speed control
1	Torque control	Torque control
2		Torque control with speed override
3		Coiler/uncoiler mode
4		Speed control with torque feed-forward
5		Bi-directional torque control with speed override

00.015 {02.004} Ramp Mode Select									
RW	Txt								US
OL	↕	Fast (0), Standard (1), Std boost (2)		⇒	Standard (1)				
RFC-A	↕	Fast (0), Standard (1)		⇒	Standard (1)				
RFC-S									

Pr 00.015 sets the ramp mode of the drive as shown below:

0: Fast ramp

Fast ramp is used where the deceleration follows the programmed deceleration rate subject to current limits. This mode must be used if a braking resistor is connected to the drive.

Safety information	Product information	Mechanical installation	Electrical installation	Getting started	Basic parameters	Running the motor	Optimization	Drive communication	NV Media Card Operation	Onboard PLC	Advanced parameters	Diagnostics	UL information
--------------------	---------------------	-------------------------	-------------------------	-----------------	-------------------------	-------------------	--------------	---------------------	-------------------------	-------------	---------------------	-------------	----------------

1: Standard ramp

Standard ramp is used. During deceleration, if the voltage rises to the standard ramp level (Pr **02.008**) it causes a controller to operate, the output of which changes the demanded load current in the motor. As the controller regulates the link voltage, the motor deceleration increases as the speed approaches zero speed. When the motor deceleration rate reaches the programmed deceleration rate the controller ceases to operate and the drive continues to decelerate at the programmed rate. If the standard ramp voltage (Pr **02.008**) is set lower than the nominal DC bus level the drive will not decelerate the motor, but it will coast to rest. The output of the ramp controller (when active) is a current demand that is fed to the frequency changing current controller (Open-loop modes) or the torque producing current controller (RFC-A or RFC-S modes). The gain of these controllers can be modified with Pr **00.038** and Pr **00.039**.

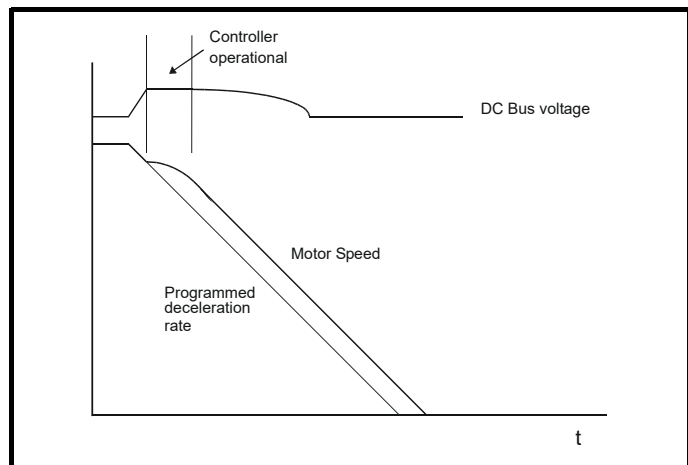

2: Standard ramp with motor voltage boost

This mode is the same as normal standard ramp mode except that the motor voltage is boosted by 20 %. This increases the losses in the motor, dissipating some of the mechanical energy as heat giving faster deceleration.

00.016 {02.002} Ramp Enable	
RW	Bit
OL	⇕
RFC-A	⇕
RFC-S	⇕
	Off (0) or On (1)
	⇒ On (1)

Setting Pr **00.016** to 0 allows the user to disable the ramps. This is generally used when the drive is required to closely follow a speed reference which already contains acceleration and deceleration ramps.

00.017 {08.026} Digital Input 6 Destination*				
RW	Num	DE	PT	US
OL	⇕	00.000 to 59.999	⇒	06.031

* Not applicable to *Unidrive M702*.

Open-loop

Pr **00.017** sets the destination of digital input T29.

00.017 {04.012} Current Reference Filter Time Constant	
RW	Num
RFC-A	⇕
RFC-S	⇕
	0.0 to 25.0 ms
	⇒ 0.0 ms

RFC-A / RFC-S

A first order filter, with a time constant defined by Pr **00.017**, is provided on the current demand to reduce acoustic noise and vibration produced as a result of position feedback quantisation noise. The filter introduces a lag in the speed loop, and so the speed loop gains may need to be reduced to maintain stability as the filter time constant is increased.

00.018 {03.123} P1 Thermistor Fault Detection	
RW	Txt
OL	None (0)
RFC-A	⇕ Temperature (1)
RFC-S	⇕ Temperature and short (2)
	⇒ Temperature (1)

Defines the fault detection for the P1 thermistor input:

P1 Thermistor Fault Detection (03.123)	Fault detection
0: None	No detection active
1: Temperature	Over temperature detection
2: Temp and short	Over temperature and short circuit detection

If over temperature detection is enabled a *Thermistor.001* trip is initiated if *P1 Thermistor Feedback* (03.119) is above the level defined by *P1 Thermistor Trip Threshold* (03.120). The trip cannot be reset until *P1 Thermistor Feedback* (03.119) is below *P1 Thermistor Reset Threshold* (03.121).

If short circuit detection is enabled then a *Th Short Circuit.001* is initiated if *P1 Thermistor Feedback* (03.119) is below 50 Ohms.

00.019 {07.011} Analog Input 2 Mode*		
RW	Num	US
OL	4-20 mA Low (-4), 20-4 mA Low (-3), 4-20 mA Hold (-2), 20-4 mA Hold (-1), 0-20 mA (0), 20-0 mA (1), 4-20 mA Trip (2), 20-4 mA Trip (3), 4-20 mA (4), 20-4 mA (5), Volt (6)	⇒ Volt (6)
RFC-A	⇕	
RFC-S	⇕	

* Not applicable to *Unidrive M702*.

In modes 2 and 3 a current loop loss trip is generated if the current falls below 3 mA.

In modes -4, -3, 2 and 3 the analog input level goes to 0.0 % if the input current falls below 3 mA.

In modes -2 and -1 the analog input remains at the value it had in the previous sample before the current fell below 3mA.

Pr Value	Pr string	Comments
-4	4-20 mA Low	4-20 mA low value on current loss (1)
-3	20-4 mA Low	20-4 mA low value on current loss (1)
-2	4-20 mA Hold	4-20 mA hold at level before loss on current loss
-1	20-4 mA Hold	20-4 mA hold at level before loss on current loss
0	0-20 mA	
1	20-0 mA	
2	4-20 mA Trip	4-20 mA trip on current loss
3	20-4 mA Trip	20-4 mA trip on current loss
4	4-20 mA	
5	20-4 mA	
6	Volt	

Safety information	Product information	Mechanical installation	Electrical installation	Getting started	Basic parameters	Running the motor	Optimization	Drive communication	NV Media Card Operation	Onboard PLC	Advanced parameters	Diagnostics	UL information
--------------------	---------------------	-------------------------	-------------------------	-----------------	------------------	-------------------	--------------	---------------------	-------------------------	-------------	---------------------	-------------	----------------

00.020 {07.014} Analog Input 2 Destination*									
RW	Num		DE				PT	US	
OL									
RFC-A	⇕	00.000 to 59.999	⇒					01.037	
RFC-S									

* Not applicable to Unidrive M702.

Pr 00.020 sets the destination of analog input 2.



00.021 {07.015} Analog Input 3 Mode*									
RW	Txt							US	
OL									
RFC-A	⇕	Volt (6), Therm Short Cct (7), Thermistor (8), Therm No Trip (9)	⇒					Volt (6)	
RFC-S									

* Not applicable to Unidrive M702.

Pr value	Pr string	Comments
6	Volt	
7	Therm Short Cct	Temperature measurement input with short circuit detection
8	Thermistor	Temperature measurement without short circuit detection
9	Therm No Trip	Temperature measurement input with no trips

00.022 {01.010} Bipolar Reference Enable									
RW	Bit							US	
OL									
RFC-A	⇕	OFF (0) or On (1)	⇒					OFF (0)	
RFC-S									

Pr 00.022 determines whether the reference is uni-polar or bi-polar as follows:

Pr 00.022	Function	
0	Unipolar speed/frequency reference	
1	Bipolar speed/frequency reference	

00.023 {01.005} Jog Reference									
RW	Num							US	
OL	⇕	0.0 to 400.0 Hz	⇒					0.0	
RFC-A	⇕	0.0 to 4000.0 rpm	⇒					0.0	
RFC-S									

Enter the required value of jog frequency/speed.

The frequency/speed limits affect the drive when jogging as follows:

Frequency-limit parameter	Limit applies
Pr 00.001 Minimum reference clamp	No
Pr 00.002 Maximum reference clamp	Yes

00.024 {01.021} Preset Reference 1									
RW	Num							US	
OL									
RFC-A	⇕	VM_SPEED_FREQ_REF	⇒					0.0	
RFC-S									

00.025 {01.022} Preset Reference 2									
RW	Num							US	
OL									
RFC-A	⇕	VM_SPEED_FREQ_REF	⇒					0.0	
RFC-S									

00.026 {01.023} Preset Reference 3 (OL)									
00.026 {03.008} Overspeed Threshold (RFC)									
RW	Num							US	
OL	⇕	VM_SPEED_FREQ_REF Hz	⇒					0.0	
RFC-A	⇕	0 to 40000 rpm	⇒						
RFC-S									

Open-loop

If the preset reference has been selected (see Pr 00.005), the speed at which the motor runs is determined by these parameters.

RFC-A / RFC-S

If the speed feedback (Pr 00.010) exceeds this level in either direction, an overspeed trip is produced. If this parameter is set to zero, the overspeed threshold is automatically set to 120 % x SPEED_FREQ_MAX.

00.027 {01.024} Preset Reference 4 (OL)									
00.027 {03.034} P1 Rotary Lines Per Revolution (RFC)									
RW	Num							US	
OL	⇕	VM_SPEED_FREQ_REF Hz	⇒					0.0	
RFC-A	⇕	1 to 100000	⇒					1024	
RFC-S								4096	

Open-loop

Refer to Pr 00.024 to Pr 00.026.

RFC-A / RFC-S

Enter in Pr 00.027 the number of lines per revolution of the drive encoder.

00.028 {06.013} Enable Auxiliary Key									
RW	Txt							US	
OL									
RFC-A	⇕	Disabled (0), Forward/Reverse (1), Run Reverse (2)	⇒					Disabled (0)	
RFC-S									

When a keypad is installed, this parameter enables the forward/reverse key.

Safety information	Product information	Mechanical installation	Electrical installation	Getting started	Basic parameters	Running the motor	Optimization	Drive communication	NV Media Card Operation	Onboard PLC	Advanced parameters	Diagnostics	UL information
--------------------	---------------------	-------------------------	-------------------------	-----------------	-------------------------	-------------------	--------------	---------------------	-------------------------	-------------	---------------------	-------------	----------------

00.029 {11.036} NV Media Card File Previously Loaded												
RO	Num					NC	PT					
OL												
RFC-A	⇕	0 to 999				⇒						
RFC-S												

This parameter shows the number of the data block last transferred from a NV Media Card to the drive.

00.030 {11.42} Parameter Cloning												
RW	Txt					NC		US*				
OL												
RFC-A	⇕	None (0), Read (1), Program (2), Auto (3), Boot (4)				⇒	None (0)					
RFC-S												

* Only a value of 3 or 4 in this parameter is saved.

NOTE

If Pr **00.030** is equal to 1 or 2 this value is not transferred to the EEPROM or the drive. If Pr **00.030** is set to a 3 or 4 the value is transferred.

Pr String	Pr value	Comment
None	0	Inactive
Read	1	Read parameter set from the NV Media Card
Program	2	Programming a parameter set to the NV Media Card
Auto	3	Auto save
Boot	4	Boot mode

For further information, please refer to Chapter 10 *NV Media Card Operation* on page 139.

00.031 {11.033} Drive Rated Voltage												
RO	Txt					ND	NC	PT				
OL												
RFC-A	⇕	200 V (0), 400 V (1), 575 V (2), 690 V (3)				⇒						
RFC-S												

Pr **00.031** indicates the voltage rating of the drive.

00.032 {11.032} Maximum Heavy Duty Rating												
RO	Num					ND	NC	PT				
OL												
RFC-A	⇕	0.000 to 99999.999 A				⇒						
RFC-S												

Pr **00.032** indicates the maximum continuous Heavy Duty current rating.

00.033 {06.009} Catch A Spinning Motor (OL)												
00.033 {05.016} Rated Speed Optimisation Select (RFC-A)												
RW	Txt									US		
OL	⇕	Disable (0), Enable (1), Fwd Only (2), Rev Only (3)				⇒	Disable (0)					
RFC-A	⇕	Disabled (0), Classic Slow (1), Classic Fast (2), Combined (3), VARs Only (4), Voltage Only (5)				⇒	Disabled (0)					

Open-loop

When the drive is enabled with Pr **00.033** = 0, the output frequency starts at zero and ramps to the required reference. When the drive is enabled when Pr **00.033** has a non-zero value, the drive performs a start-up test to determine the motor speed and then sets the initial output frequency to the synchronous frequency of the motor. Restrictions may be placed on the frequencies detected by the drive as follows:

Pr 00.033	Pr string	Function
0	Disable	Disabled
1	Enable	Detect all frequencies
2	Fwd only	Detect positive frequencies only
3	Rev only	Detect negative frequencies only

RFC-A

The *Rated Frequency* (00.047) and *Rated Speed* (00.045) are used to define the rated slip of the motor. The rated slip is used in sensorless mode (*Sensorless Mode Active* (03.078) = 1) to correct the motor speed with load. When this mode is active *Rated Speed Optimisation Select* (00.033) has no effect.

If sensorless mode is not active (*Sensorless Mode Active* (03.078) = 0) the rated slip is used in the motor control algorithm and an incorrect value of slip can have a significant effect on the motor performance. If *Rated Speed Optimisation Select* (00.033) = 0 then the adaptive control system is disabled. However, if *Rated Speed Optimisation Select* (00.033) is set to a non-zero value the drive can automatically adjust the *Rated Speed* (00.045) to give the correct value of rated slip. *Rated Speed* (00.045) is not saved at power-down, and so when the drive is powered-down and up again it will return to the last value saved by the user. The rate of convergence and the accuracy of the adaptive controller reduces at low output frequency and low load. The minimum frequency is defined as a percentage of *Rated Frequency* (00.047) by *Rated Speed Optimisation Minimum Frequency* (05.019). The minimum load is defined as a percentage of rated load by *Rated Speed Optimisation Minimum Load* (05.020). The adaptive controller is enabled when a motoring or regenerative load rises above *Rated Speed Optimisation Minimum Load* (05.020) + 5 %, and is disabled again when it falls below *Rated Speed Optimisation Minimum Load* (05.020). For best optimisation results the correct values of *Stator Resistance* (05.017), *Transient Inductance* (05.024), *Stator Inductance* (05.025), *Saturation Breakpoint 1* (05.029), *Saturation Breakpoint 2* (05.062), *Saturation Breakpoint 3* (05.030) and *Saturation Breakpoint 4* (05.063) should be used.

00.034 {11.030} User security code												
RW	Num					ND	NC	PT	US			
OL												
RFC-A	⇕	0 to 2 ³¹ -1				⇒	0					
RFC-S												

If any number other than 0 is programmed into this parameter, user security is applied so that no parameters except Pr **00.049** can be adjusted with the keypad. When this parameter is read via a keypad it appears as zero. For further details refer to section 5.9.3 *User Security Code* on page 46.

Safety information	Product information	Mechanical installation	Electrical installation	Getting started	Basic parameters	Running the motor	Optimization	Drive communication	NV Media Card Operation	Onboard PLC	Advanced parameters	Diagnostics	UL information
--------------------	---------------------	-------------------------	-------------------------	-----------------	------------------	-------------------	--------------	---------------------	-------------------------	-------------	---------------------	-------------	----------------

RW		Txt		US	
00.035 {11.024} Serial Mode*					
OL		8 2 NP (0), 8 1 NP (1), 8 1 EP (2), 8 1 OP (3),			
RFC-A	↕	8 2 NP M (4), 8 1 NP M (5), 8 1 EP M (6),			
RFC-S	↕	8 1 OP M (7), 7 2 NP (8), 7 1 NP (9), 7 1 EP (10), 7 1 OP (11), 7 2 NP M (12), 7 1 NP M (13), 7 1 EP M (14), 7 1 OP M (15)	⇒	8 2 NP (0)	

* Only applicable to Unidrive M701.

This parameter defines the communications protocol used by the EIA485 comms port on the drive. This parameter can be changed via the drive keypad, via a Solutions Module or via the comms interface itself. If it is changed via the comms interface, the response to the command uses the original protocol. The master should wait at least 20 ms before send a new message using the new protocol. (Note: ANSI uses 7 data bits, 1 stop bit and even parity; Modbus RTU uses 8 data bits, 2 stops bits and no parity).

Pr Value	Pr String
0	8 2 NP
1	8 1 NP
2	8 1 EP
3	8 1 OP
4	8 2 NP M
5	8 1 NP M
6	8 1 EP M
7	8 1 OP M
8	7 2 NP
9	7 1 NP
10	7 1 EP
11	7 1 OP
12	7 2 NP M
13	7 1 NP M
14	7 1 EP M
15	7 1 OP M

The core drive always uses the Modbus rtu protocol and is always a slave. *Serial Mode* (00.035) defines the data format used by the serial comms interface. The bits in the value of *Serial Mode* (00.035) define the data format as follows. Bit 3 is always 0 in the core product as 8 data bits are required for Modbus rtu. The parameter value can be extended in derivative products which provide alternative communications protocols if required.

Bits	3	2	1 and 0
Format	Number of data bits 0 = 8 bits 1 = 7 bits	Register mode 0 = Standard 1 = Modified	Stop bits and Parity 0 = 2 stop bits, no parity 1 = 1 stop bit, no parity 2 = 1 stop bit, even parity 3 = 1 stop bit, odd parity

Bit 2 selects either standard or modified register mode. The menu and parameter numbers are derived for each mode as given in the following table. Standard mode is compatible with Unidrive SP. Modified mode is provided to allow register numbers up to 255 to be addressed. If any menus with numbers above 63 should contain more than 99 parameters, then these parameters cannot be accessed via Modbus rtu.

Register mode	Register address
Standard	(mm x 100) + ppp - 1 where mm ≤ 162 and ppp ≤ 99
Modified	(mm x 256) + ppp - 1 where mm ≤ 63 and ppp ≤ 255

Changing the parameters does not immediately change the serial communications settings. See *Reset Serial Communications* (11.020) for more details.

RW		Txt		US	
00.036 {11.025} Serial Baud Rate*					
OL		300 (0), 600 (1), 1200 (2), 2400 (3), 4800 (4),			
RFC-A	↕	9600 (5), 19200 (6), 38400 (7), 57600 (8),	⇒	19200 (6)	
RFC-S	↕	76800 (9), 115200 (10)			

* Only applicable to Unidrive M701.

This parameter can be changed via the drive keypad, via a Solutions Module or via the comms interface itself. If it is changed via the comms interface, the response to the command uses the original baud rate. The master should wait at least 20 ms before send a new message using the new baud rate.

RW		Num		US	
00.037 {11.023} Serial Address*					
OL					
RFC-A	↕	1 to 247	⇒	1	
RFC-S	↕				

* Only applicable to Unidrive M701.

Used to define the unique address for the drive for the serial interface. The drive is always a slave address 0 is used to globally address all slaves, and so this address should not be set in this parameter

RO		IP		NC		PT	
00.037 {24.010} Active IP Address*							
OL							
RFC-A	↕	0.0.0.0 to 255.255.255.255	⇒				
RFC-S	↕						

* Only applicable to Unidrive M700 and Unidrive M702.

RW		Num		US	
00.038 {04.013} Current Controller Kp Gain					
OL					20
RFC-A	↕	0 to 30000	⇒		150
RFC-S	↕				

RW		Num		US	
00.039 {04.014} Current Controller Ki Gain					
OL	↕		⇒		40
RFC-A	↕	0 to 30000	⇒		2000
RFC-S	↕				

These parameters control the proportional and integral gains of the current controller used in the open loop drive. The current controller either provides current limits or closed loop torque control by modifying the drive output frequency. The control loop is also used in its torque mode during line power supply loss, or when the controlled mode standard ramp is active and the drive is decelerating, to regulate the flow of current into the drive.

Safety information	Product information	Mechanical installation	Electrical installation	Getting started	Basic parameters	Running the motor	Optimization	Drive communication	NV Media Card Operation	Onboard PLC	Advanced parameters	Diagnostics	UL information
--------------------	---------------------	-------------------------	-------------------------	-----------------	------------------	-------------------	--------------	---------------------	-------------------------	-------------	---------------------	-------------	----------------

00.040 {05.012}		Auto-tune												
RW	Num												NC	
OL	↕	0 to 2						⇒	0					
RFC-A	↕	0 to 5						⇒						
RFC-S	↕	0 to 6						⇒						

Open-Loop

There are two autotune tests available in open loop mode, a stationary and a rotating test. A rotating autotune should be used whenever possible so the measured value of power factor of the motor is used by the drive.

- A stationary autotune can be used when the motor is loaded and it is not possible to remove the load from the motor shaft. The stationary test measures the *Stator Resistance* (05.017), *Transient Inductance* (05.024), *Maximum Deadtime Compensation* (05.059) and *Current At Maximum Deadtime Compensation* (05.060) which are required for good performance in vector control modes (see *Open Loop Control Mode* (00.007), later in this table). The stationary autotune does not measure the power factor of the motor so the value on the motor nameplate must be entered into Pr **00.043**. To perform a Stationary autotune, set Pr **00.040** to 1, and provide the drive with both an enable signal (terminal 31 on *Unidrive M700 / M701* and terminal 11 and 13 on *Unidrive M702*) and a run signal (terminal 26 or 27 on *Unidrive M700 / M701* and terminal 7 or 8 on *Unidrive M702*).
- A rotating autotune should only be used if the motor is unloaded. A rotating autotune first performs a stationary autotune, as above, then a rotating test is performed in which the motor is accelerated with currently selected ramps up to a frequency of *Rated Frequency* (05.006) x 2/3, and the frequency is maintained at that level for 4 seconds. *Stator Inductance* (05.025) is measured and this value is used in conjunction with other motor parameters to calculate *Rated Power Factor* (00.043). To perform a Rotating autotune, set Pr **00.040** to 2, and provide the drive with both an enable signal (terminal 31 on *Unidrive M700 / M701* and terminal 11 & 13 on *Unidrive M702*) and a run signal (terminal 26 or 27 on *Unidrive M700 / M701* and terminal 7 or 8 on *Unidrive M702*).

Following the completion of an autotune test the drive will go into the inhibit state. The drive must be placed into a controlled disable condition before the drive can be made to run at the required reference. The drive can be put in to a controlled disable condition by removing the Safe Torque Off signal from terminal 31 on *Unidrive M700 / M701* and terminal 11 & 13 on *Unidrive M702*, setting the *Drive Enable* (06.015) to OFF (0) or disabling the drive via the *Control Word* (06.042) and *Control Word Enable* (06.043).

RFC-A

There are four autotune tests available in RFC-A mode, a stationary test, a rotating test, two mechanical load measurement tests. A stationary autotune will give moderate performance whereas a rotating autotune will give improved performance as it measures the actual values of the motor parameters required by the drive. A mechanical load measurement test should be performed separately to a stationary or rotating autotune.

NOTE

It is highly recommended that a rotating autotune is performed (Pr **00.040** set to 2).

- A stationary autotune can be used when the motor is loaded and it is not possible to remove the load from the motor shaft. The stationary autotune measures the *Stator Resistance* (05.017) and *Transient Inductance* (05.024) of the motor. These are used to calculate the current loop gains, and at the end of the test the values in Pr **00.038** and Pr **00.039** are updated. A stationary autotune does not measure the power factor of the motor so the value on the motor nameplate

must be entered into Pr **00.043**. To perform a Stationary autotune, set Pr **00.040** to 1, and provide the drive with both an enable signal (terminal 31 on *Unidrive M700 / M701* and terminal 11 & 13 on *Unidrive M702*) and a run signal (terminal 26 or 27 on *Unidrive M700 / M701* and terminal 7 or 8 on *Unidrive M702*).

- A rotating autotune should only be used if the motor is unloaded. A rotating autotune first performs a stationary autotune, a rotating test is then performed which the motor is accelerated with currently selected ramps up to a frequency of *Rated Frequency* (00.047) x 2/3, and the frequency is maintained at the level for up to 40 s. During the rotating autotune the *Stator Inductance* (05.025), and the motor saturation breakpoints (Pr **05.029**, Pr **05.030**, Pr **06.062** and Pr **05.063**) are modified by the drive. The *Motor Rated Power Factor* (00.043) is also modified by the *Stator Inductance* (05.025). The No-Load motor core losses are measured and written to *No-Load Core Loss* (04.045). To perform a Rotating autotune, set Pr **00.040** to 2, and provide the drive with both an enable signal (terminal 31 on *Unidrive M700 / M701* and terminal 11 and 13 on *Unidrive M702*) and a run signal (terminal 26 or 27 on *Unidrive M700 / M701* and terminal 7 or 8 on *Unidrive M702*).

Following the completion of an autotune test the drive will go into the inhibit state. The drive must be placed into a controlled disable condition before the drive can be made to run at the required reference. The drive can be put in to a controlled disable condition by removing the Safe Torque Off signal from terminal 31 on *Unidrive M700 / M701* and terminal 11 and 13 on *Unidrive M702*, setting the *Drive Enable* (06.015) to OFF (0) or disabling the drive via the control word (Pr **06.042** & Pr **06.043**).

RFC-S

There are five autotune tests available in RFC-S mode, a stationary autotune, a rotating autotune, two mechanical load measurement tests and a locked rotor test to measure load dependent parameters.

Stationary Autotune

The stationary autotune can be used when the motor is loaded and it is not possible uncouple the load from motor shaft. This test can be used to measure all the necessary parameters for basic control. During the stationary autotune, a test is performed to locate the flux axis of the motor. However this test may not be able to calculate such an accurate value for the *Position Feedback Phase Angle* (00.043) as compared to rotating autotune. A stationary test is performed to measure *Stator Resistance* (05.017), *Ld* (05.024), *Maximum Deadtime Compensation* (05.059), *Current At Maximum Deadtime Compensation* (05.060), *No Load Lq* (05.072). If *Enable Stator Compensation* (05.049) = 1 then *Stator Base Temperature* (05.048) is made equal to *Stator Temperature* (05.046). The *Stator Resistance* (05.017) and the *Ld* (05.024) are then used to set up *Current controller Kp Gain* (00.038) and *Current Controller Ki Gain* (00.039). If sensorless mode is not selected then *Position Feedback Phase Angle* (00.043) is set up for the position from the position feedback interface selected with *Motor Control Feedback Select* (03.026). To perform a Stationary autotune, set Pr **00.040** to 1, and provide the drive with both an enable signal (terminal 31 on *Unidrive M700 / M701* and terminal 11 & 13 on *Unidrive M702*) and a run signal (terminal 26 or 27 on *Unidrive M700 / M701* and terminal 7 or 8 on *Unidrive M702*).

Rotating Autotune

The rotating autotune must be performed on unloaded motor. This test can be used to measure all the necessary parameters for the basic control and parameters for cancelling the effects of the cogging torque.

During the rotating autotune, *Rated Current* (00.046) is applied and the motor is rotated by 2 electrical revolutions (i.e. up to 2 mechanical revolutions) in the required direction. If sensorless mode is not selected then the *Position Feedback Phase Angle* (00.043) is set-up for the position from the position feedback interface selected with *Motor Control Feedback Select* (03.026). A stationary test is then performed to measure *Stator Resistance* (05.017), *Ld* (05.024), *Maximum Deadtime Compensation* (05.059), *Current At Maximum Deadtime Compensation* (05.060) and *No Load Lq* (05.072). *Stator Resistance* (05.017) and *Ld*

Safety information	Product information	Mechanical installation	Electrical installation	Getting started	Basic parameters	Running the motor	Optimization	Drive communication	NV Media Card Operation	Onboard PLC	Advanced parameters	Diagnostics	UL information
--------------------	---------------------	-------------------------	-------------------------	-----------------	------------------	-------------------	--------------	---------------------	-------------------------	-------------	---------------------	-------------	----------------

(05.024) are used to set up *Current Controller Kp Gain* (00.038) and *Current Controller Ki Gain* (00.039). This is only done once during the test, and so the user can make further adjustments to the current controller gains if required. To perform a Rotating autotune, set Pr **00.040** to 2, and provide the drive with both an enable signal (terminal 31 on *Unidrive M700 / M701* and terminal 11 and 13 on *Unidrive M702*) and a run signal (terminal 26 or 27 on *Unidrive M700 / M701* and terminal 7 or 8 on *Unidrive M702*).

00.041 {05.018}		Maximum Switching Frequency			
RW	Txt	RA	NC		
OL	↕	2 kHz (0), 3 kHz (1), 4 kHz (2), 6 kHz (3), 8 kHz (4), 12 kHz (5), 16 kHz (6)	⇒	3 kHz (1)	
RFC-A				6 kHz (3)	
RFC-S					

This parameter defines the required switching frequency. The drive may automatically reduce the actual switching frequency (without changing this parameter) if the power stage becomes too hot. A thermal model of the IGBT junction temperature is used based on the heatsink temperature and an instantaneous temperature drop using the drive output current and switching frequency. The estimated IGBT junction temperature is displayed in Pr **07.034**. If the temperature exceeds 135 °C the switching frequency is reduced if this is possible (i.e >3 kHz). Reducing the switching frequency reduces the drive losses and the junction temperature displayed in Pr **07.034** also reduces. If the load condition persists the junction temperature may continue to rise again above 145 °C and the drive cannot reduce the switching frequency further the drive will initiate an 'OHT Inverter' trip. Every second the drive will attempt to restore the switching frequency to the level set in Pr **00.041**.

The full range of switching frequencies is not available on all ratings of Unidrive M. See section 8.5 *Switching frequency* on page 109, for the maximum available switching frequency for each drive rating.

6.4.7 Motor parameters

00.042 {05.011}		Number Of Motor Poles			
RW	Num	RA	NC		US
OL	↕	Automatic (0) to 480 Poles (240)	⇒	Automatic (0)	
RFC-A				6 Poles (3)	
RFC-S					

Open-loop

This parameter is used in the calculation of motor speed, and in applying the correct slip compensation. When Automatic (0) is selected, the number of motor poles is automatically calculated from the *Rated Frequency* (00.047) and the *Rated Speed* rpm (00.045). The number of poles = 120 * rated frequency / rpm rounded to the nearest even number.

RFC-A

This parameter must be set correctly for the vector control algorithms to operate correctly. When Automatic (0) is selected, the number of motor poles is automatically calculated from the *Rated Frequency* (00.047) and the *Rated Speed* (00.045) rpm. The number of poles = 120 * rated frequency / rpm rounded to the nearest even number.

RFC-S

This parameter must be set correctly for the vector control algorithms to operate correctly. When Automatic (0) is selected the number of poles is set to 6.

00.043 {05.010}		Rated Power Factor (OL)			
00.043 {03.025}		Position Feedback Phase Angle (RFC)			
RW	Num	RA	NC		US
OL	↕	0.000 to 1.000	⇒	0.850	
RFC-A				0.850	
RFC-S				0.0 to 359.9 °	

The power factor is the true power factor of the motor, i.e. the angle between the motor voltage and current.

Open-loop

The power factor is used in conjunction with the motor rated current (Pr **00.046**) to calculate the rated active current and magnetizing current of the motor. The rated active current is used extensively to control the drive, and the magnetizing current is used in vector mode Rs compensation. It is important that this parameter is set up correctly.

This parameter is obtained by the drive during a rotational autotune. If a stationary autotune is carried out, then the nameplate value should be entered in Pr **00.043**.

RFC-A

If the stator inductance (Pr **05.025**) contains a non-zero value, the power factor used by the drive is continuously calculated and used in the vector control algorithms (this will not update Pr **00.043**).

If the stator inductance is set to zero (Pr **05.025**) then the power factor written in Pr **00.043** is used in conjunction with the motor rated current and other motor parameters to calculate the rated active and magnetizing currents which are used in the vector control algorithm.

This parameter is obtained by the drive during a rotational autotune. If a stationary autotune is carried out, then the nameplate value should be entered in Pr **00.043**.

RFC-S

The phase angle between the rotor flux in a servo motor and the encoder position is required for the motor to operate correctly. If the phase angle is known it can be set in this parameter by the user. Alternatively the drive can automatically measure the phase angle by performing a phasing test (see autotune in RFC-S mode Pr **00.040**). When the test is complete the new value is written to this parameter. The encoder phase angle can be modified at any time and becomes effective immediately. This parameter has a factory default value of 0.0 °, but is not affected when defaults are loaded by the user.

00.044 {05.009}		Rated Voltage			
RW	Num	RA	NC		US
OL	↕	0 to VM_AC_VOLTAGE_ SET	⇒	200 V drive: 230 V	
RFC-A				50Hz default 400 V drive: 400 V	
RFC-S				60Hz default 400 V drive: 460 V 575 V drive: 575 V 690 V drive: 690 V	

Enter the value from the rating plate of the motor.

00.045 {05.008}		Rated Speed			
RW	Num	RA	NC		US
OL	↕	0 to 35940 rpm	⇒	50 Hz default: 1500 rpm 60 Hz default: 1800 rpm	
RFC-A				50 Hz default: 1450.00 rpm 60 Hz default: 1750.00 rpm	
RFC-S				3000.00 rpm	

Open-loop

This is the speed at which the motor would rotate when supplied with its base frequency at rated voltage, under rated load conditions (= synchronous speed - slip speed). Entering the correct value into this parameter allows the drive to increase the output frequency as a

Safety information	Product information	Mechanical installation	Electrical installation	Getting started	Basic parameters	Running the motor	Optimization	Drive communication	NV Media Card Operation	Onboard PLC	Advanced parameters	Diagnostics	UL information
--------------------	---------------------	-------------------------	-------------------------	-----------------	-------------------------	-------------------	--------------	---------------------	-------------------------	-------------	---------------------	-------------	----------------

function of load in order to compensate for this speed drop.

Slip compensation is disabled if Pr **00.045** is set to 0 or to synchronous speed, or if Pr **05.027** is set to 0.

If slip compensation is required this parameter should be set to the value from the rating plate of the motor, which should give the correct rpm for a hot machine. Sometimes it will be necessary to adjust this when the drive is commissioned because the nameplate value may be inaccurate. Slip compensation will operate correctly both below base speed and within the field weakening region. Slip compensation is normally used to correct for the motor speed to prevent speed variation with load. The rated load rpm can be set higher than synchronous speed to deliberately introduce speed droop. This can be useful to aid load sharing with mechanically coupled motors.

RFC-A

Rated speed is used with motor rated frequency to determine the full load slip of the motor which is used by the vector control algorithm. Incorrect setting of this parameter can result in the following:

- Reduced efficiency of motor operation
- Reduction of maximum torque available from the motor
- Failure to reach maximum speed
- Over-current trips
- Reduced transient performance
- Inaccurate control of absolute torque in torque control modes

The nameplate value is normally the value for a hot machine, however, some adjustment may be required when the drive is commissioned if the nameplate value is inaccurate.

The rated speed rpm can be optimized by the drive (For further information, refer to section 8.1.2 *RFC-A mode* on page 98).

RFC-S

Rated Speed (00.045) is used as follows:

1. Operation without position feedback, i.e. Sensorless Mode Active (03.078) = 1.
2. Where the motor operates above this speed and flux weakening is active.
3. In the motor thermal model.

The units for *Rated Speed* (00.045) are always rpm even if a linear motor is used and *Linear Speed Select* (01.055) = 1.

00.046 {05.007} Rated Current	
RW	Num
OL	RA
RFC-A	US
RFC-S	
	0.000 to VM_RATED_CURRENT
	Maximum Heavy Duty Rating (00.032)

Enter the name-plate value for the motor rated current.

00.047 {05.006} Rated Frequency	
RW	Num
OL	US
RFC-A	
RFC-S	
	0.0 to 599.0 Hz
	50 Hz default: 50.0 Hz 60 Hz default: 60.0 Hz
	0.0 to 550.0 Hz

Open-loop and RFC-A

Enter the value from the rating plate of the motor.

6.4.8 Operating-mode selection

00.048 {11.031} User Drive Mode	
RW	Txt
OL	ND NC PT
RFC-A	
RFC-S	
Regen	
	Open-loop (1)
	RFC-A (2)
	RFC-S (3)
	Regen (4)

The settings for Pr **00.048** are as follows:

Setting	Operating mode
1	Open-loop
2	RFC-A
3	RFC-S
4	Regen

This parameter defines the drive operating mode. Pr **mm.000** must be set to '1253' (European defaults) or '1254' (USA defaults) before this parameter can be changed. When the drive is reset to implement any change in this parameter, the default settings of all parameters will be set according to the drive operating mode selected and saved in memory.

6.4.9 Status information

00.049 {11.044} User Security Status	
RW	Txt
OL	ND PT
RFC-A	
RFC-S	
	Menu 0 (0), All Menus (1), Read-only Menu 0 (2), Read-only (3), Status Only (4), No Access (5)
	Menu 0 (0)

This parameter controls access via the drive keypad as follows:

Security level	Description
0 (Menu 0)	All writable parameters are available to be edited but only parameters in Menu 0 are visible.
1 (All Menus)	All writable parameters are visible and available to be edited.
2 (Read-only Menu 0)	All parameters are read-only. Access is limited to Menu 0 parameters only.
3 (Read-only)	All parameters are read-only however all menus and parameters are visible.
4 (Status Only)	The keypad remains in status mode and no parameters can be viewed or edited.
5 (No Access)	The keypad remains in status mode and no parameters can be viewed or edited. Drive parameters cannot be accessed via a comms / fieldbus interface in the drive or any option module.

The keypad can adjust this parameter even when user security is set.

00.050 {11.029} Software Version	
RO	Num
OL	ND NC PT
RFC-A	
RFC-S	
	0 to 99999999

The parameter displays the software version of the drive.

Safety information	Product information	Mechanical installation	Electrical installation	Getting started	Basic parameters	Running the motor	Optimization	Drive communication	NV Media Card Operation	Onboard PLC	Advanced parameters	Diagnostics	UL information
--------------------	---------------------	-------------------------	-------------------------	-----------------	------------------	-------------------	--------------	---------------------	-------------------------	-------------	---------------------	-------------	----------------

00.051 {10.037} Action On Trip Detection										
RW	Bin								US	
OL										
RFC-A	⇕	0 to 31				⇒	0			
RFC-S										

Each bit in this parameter has the following functions:

Bit	Function
0	Stop on non-important trips
1	Disable braking resistor overload detection
2	Disable phase loss stop
3	Disable braking resistor temperature monitoring
4	Disable parameter freeze on trip

Example

Pr 00.051 =8 (1000_{binary}) Th Brake Res trip is disabled

Pr 00.051 =12 (1100_{binary}) Th Brake Res and phase loss trip is disabled

Stop on non-important trips

If bit 0 is set to one the drive will attempt to stop before tripping if any of the following trip conditions are detected: I/O Overload, An Input 1 Loss, An Input 2 Loss or Keypad Mode.

Disable braking resistor overload detection

For details of braking resistor overload detection mode see Pr 10.030.

Disable phase loss trip

Normally the drive will stop when the input phase loss condition is detected. If this bit is set to 1 the drive will continue to run and will only trip when the drive is brought to a stop by the user.

Disable braking resistor temperature monitoring

Size 3, 4 and 5 drives have an internal user install braking resistor with a thermistor to detect overheating of the resistor. As default bit 3 of Pr 00.051 is set to zero, and so if the braking resistor and its thermistor is not installed the drive will produce a trip (Th Brake Res) because the thermistor appears to be open-circuit. This trip can be disabled so that the drive can run by setting bit 3 of Pr 00.051 to one. If the resistor is installed then no trip is produced unless the thermistor fails, and so bit 3 of Pr 00.051 can be left at zero. This feature only applies to size 3, 4 and 5 drives. For example if Pr 00.051 = 8, then Th Brake Res trip will be disabled.

Disable parameter freeze on trip

If this bit is 0 then the parameters listed below are frozen on trip until the

trip is cleared. If this bit is 1 then this feature is disabled.

Open-loop mode	RFC-A and RFC-S modes
Reference Selected (01.001)	Reference Selected (01.001)
Pre-skip Filter Reference (01.002)	Pre-skip Filter Reference (01.002)
Pre-ramp Reference (01.003)	Pre-ramp Reference (01.003)
Post Ramp Reference (02.001)	Post Ramp Reference (02.001)
Frequency Slaving Demand (03.001)	Final Speed Reference (03.001)
	Speed Feedback (00.010)
	Speed Error (03.003)
	Speed Controller Output (03.004)
Current Magnitude (00.012)	Current Magnitude (00.012)
Torque Producing Current (00.013)	Torque Producing Current (00.013)
Magnetising Current (04.017)	Magnetising Current (04.017)
Output Frequency (00.011)	Output Frequency (00.011)
Output Voltage (05.002)	Output Voltage (05.002)
Output Power (05.003)	Output Power (05.003)
D.c. Bus Voltage (05.005)	D.c. Bus Voltage (05.005)
Analog Input 1 (07.001)*	Analog Input 1 (07.001)*
Analog Input 2 (07.002)*	Analog Input 2 (07.002)*
Analog Input 3 (07.003)*	Analog Input 3 (07.003)*

*Not applicable to Unidrive M702

00.052 {11.020} Reset Serial Communications*										
RW	Bit					ND	NC			
OL										
RFC-A	⇕	Off (0) or On (1)				⇒	Off (0)			
RFC-S										

* Only applicable to Unidrive M701.

When *Serial Address* (00.037), *Serial Mode* (00.035), *Serial Baud Rate* (00.036), *Minimum Comms Transmit Delay* (11.026) or *Silent Period* (11.027) are modified the changes do not have an immediate effect on the serial communications system. The new values are used after the next power-up or if *Reset Serial Communications* (00.052) is set to one. *Reset Serial Communications* (00.052) is automatically cleared to zero after the communications system is updated.

00.053 {04.015} Motor Thermal Time Constant										
RW	Num								US	
OL										
RFC-A	⇕	1.0 to 3000.0 s				⇒	89.0 s			
RFC-S										

Pr 00.053 is the motor thermal time constant of the motor, and is used (along with the motor rated current Pr 00.046, and total motor current Pr 00.012) in the thermal model of the motor in applying thermal protection to the motor.

For further details, refer to section 8.4 *Motor thermal protection* on page 108.

7 Running the motor

This chapter takes the new user through all the essential steps to running a motor for the first time, in each of the possible operating modes.

For information on tuning the drive for the best performance, see *Chapter 8 Optimization* on page 95.



Ensure that no damage or safety hazard could arise from the motor starting unexpectedly.

WARNING



The values of the motor parameters affect the protection of the motor. The default values in the drive should not be relied upon. It is essential that the correct value is entered in Pr **00.046 Rated Current**. This affects the thermal protection of the motor.

CAUTION



If the drive is started using the keypad it will run to the speed defined by the keypad reference (Pr **01.017**). This may not be acceptable depending on the application. The user must check in Pr **01.017** and ensure that the keypad reference has been set to 0.

CAUTION



If the intended maximum speed affects the safety of the machinery, additional independent over-speed protection must be used.

WARNING

7.1 Quick start connections

7.1.1 Basic requirements

This section shows the basic connections which must be made for the drive to run in the required mode. For minimal parameter settings to run in each mode please see the relevant part of section 7.3 *Quick start commissioning / start-up* on page 78.

Table 7-1 Minimum control connection requirements for each control mode

Drive control method	Requirements
Terminal mode	Drive enable Speed / Torque reference Run forward / Run reverse
Keypad mode	Drive enable
Communications link	Drive enable Communications link

Table 7-2 Minimum control connection requirements for each mode of operation

Operating mode	Requirements
Open loop mode	Induction motor
RFC – A mode (with speed feedback)	Induction motor with speed feedback
RFC - S mode (with speed and position feedback)	Permanent magnet motor with speed and position feedback

Speed feedback

Suitable devices are:

- Incremental encoder (A, B or F, D with or without Z)
- Incremental encoder with forward and reverse outputs (F, R with or without Z)
- SINCOS encoder (with, or without Stegmann Hiperface, EnDat or SSI communications protocols)
- EnDat absolute encoder
- Resolver

Speed and position feedback

Suitable devices are:

- Incremental encoder (A, B or F, D with or without Z) with commutation signals (U, V, W)
- Incremental encoder with forward and reverse outputs (F, R with or without Z) and commutation outputs (U, V, W)
- SINCOS encoder (with Stegmann Hiperface, EnDat or SSI communications protocols)
- EnDat absolute encoder
- Resolver

7.2 Changing the operating mode

Changing the operating mode returns all parameters to their default value, including the motor parameters. *User Security Status* (Pr **00.049**) and *User Security Code* (Pr **00.034**) are not affected by this procedure.

Procedure

Use the following procedure only if a different operating mode is required:

1. Enter either of the following values in Pr **mm.000**, as appropriate:
1253 (50 Hz AC supply frequency)
1254 (60 Hz AC supply frequency)
2. Change the setting of Pr **00.048** as follows:

Pr 00.048 setting		Operating mode
	1	Open-loop
	2	RFC-A
	3	RFC-S
	4	Regen

The figures in the second column apply when the communications interface is used.

3. Either:
 - Press the red reset button
 - Toggle the reset digital input
 - Carry out a drive reset through the communications interface by setting Pr **10.038** to 100 (ensure that Pr **mm.000** returns to 0).

Figure 7-1 Minimum connections to get the motor running in any operating mode for Unidrive M700 / M701 (size 3 and 4)

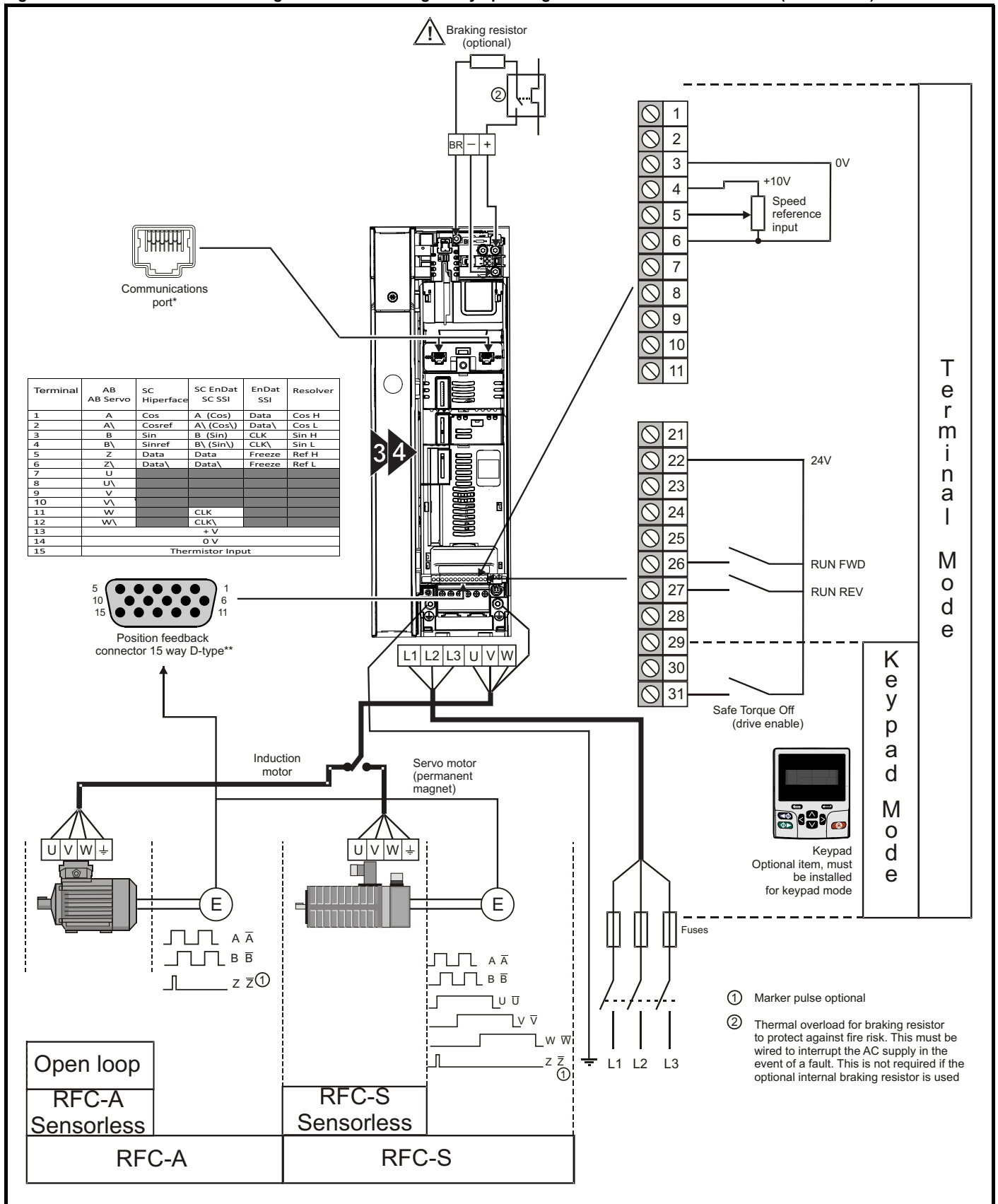

* Ethernet fieldbus communication ports on Unidrive M700 and EIA 485 serial communication ports on Unidrive M701.

** Position feedback port.

Figure 7-2 Minimum connections to get the motor running in any operating mode for Unidrive M702 (size 3 and 4)

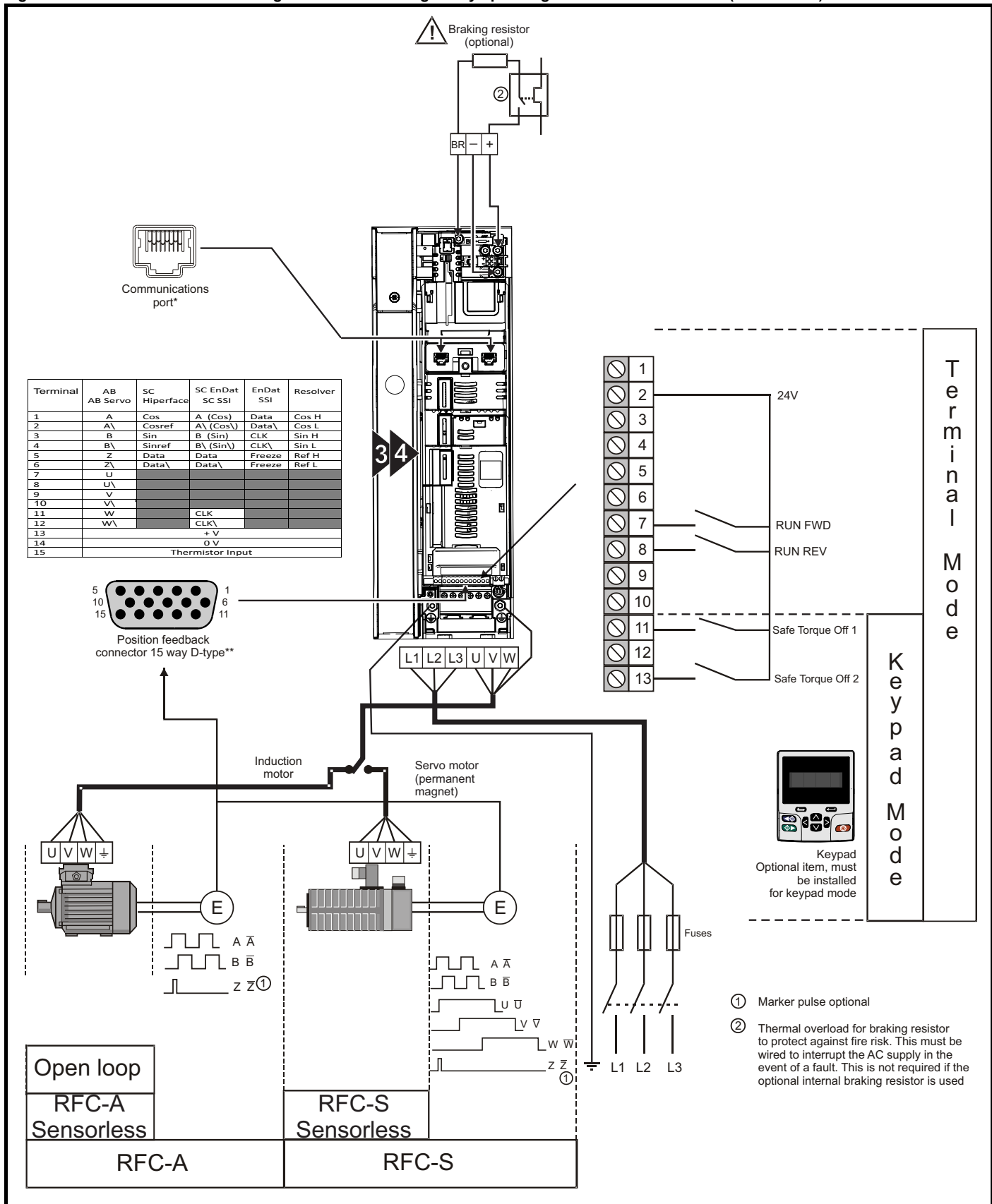

* Ethernet fieldbus communication ports.

** Position feedback port.

Figure 7-3 Minimum connections to get the motor running in any operating mode for Unidrive M700 / M701 (size 5)

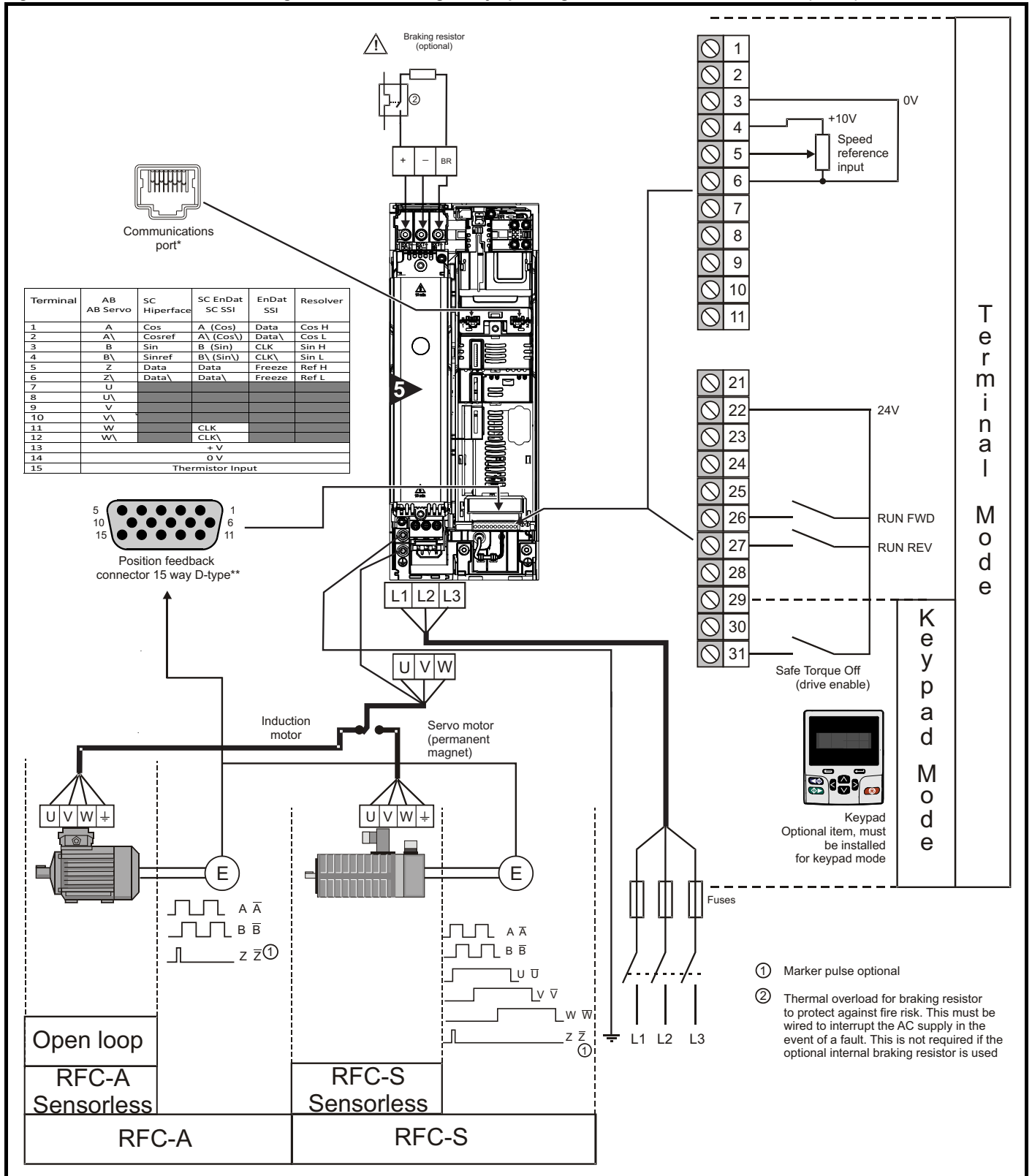

* Ethernet fieldbus communication ports on Unidrive M700 and EIA 485 serial communication ports on Unidrive M701.

** Position feedback port.

Figure 7-4 Minimum connections to get the motor running in any operating mode for Unidrive M702 (size 5)

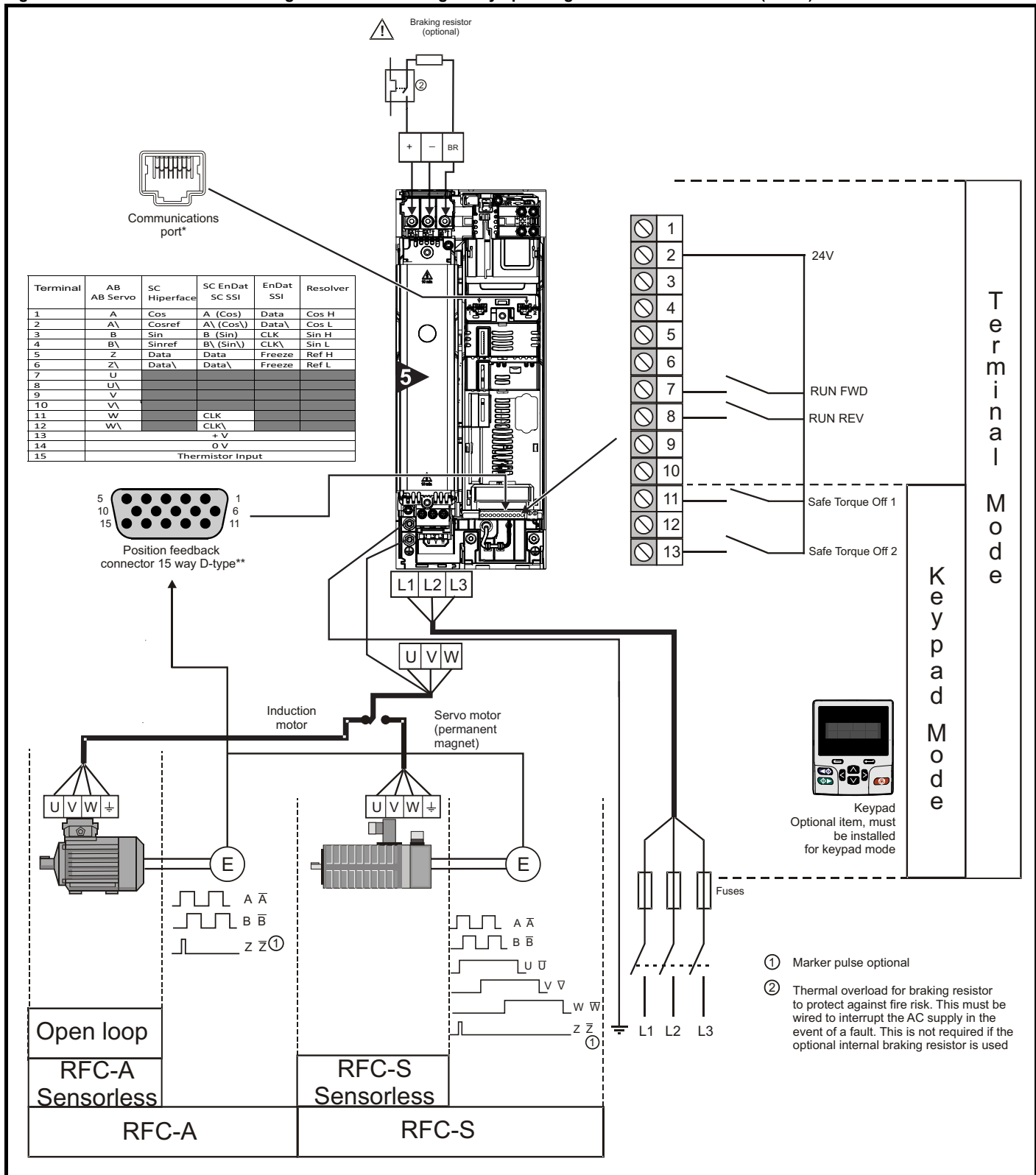

* Ethernet fieldbus communication ports.

** Position feedback port.

Figure 7-5 Minimum connections to get the motor running in any operating mode for Unidrive M700 / M701 (size 6)

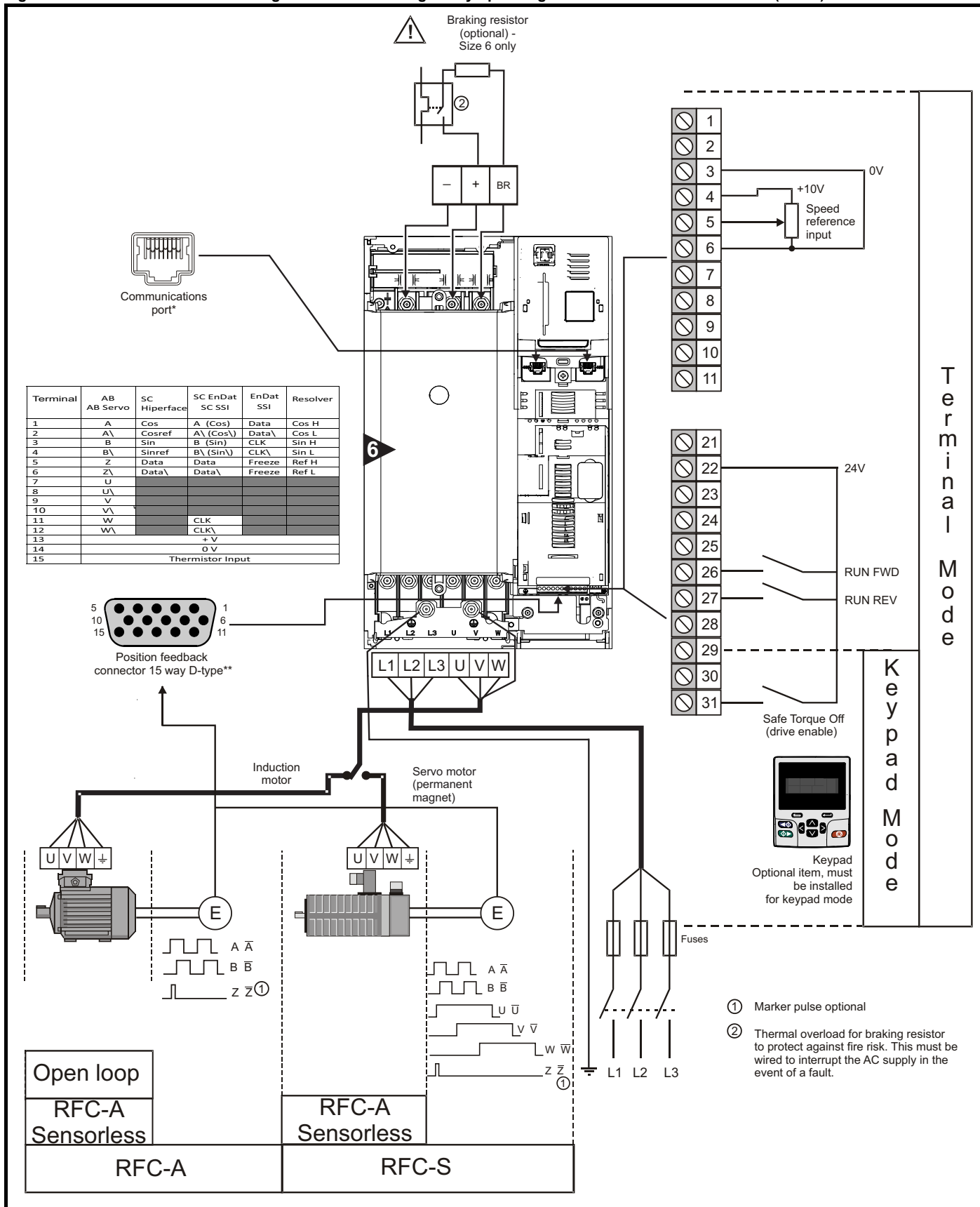

* Ethernet fieldbus communication ports on Unidrive M700 and EIA 485 serial communication ports on Unidrive M701.

** Position feedback port.

Figure 7-6 Minimum connections to get the motor running in any operating mode for Unidrive M702 (size 6)

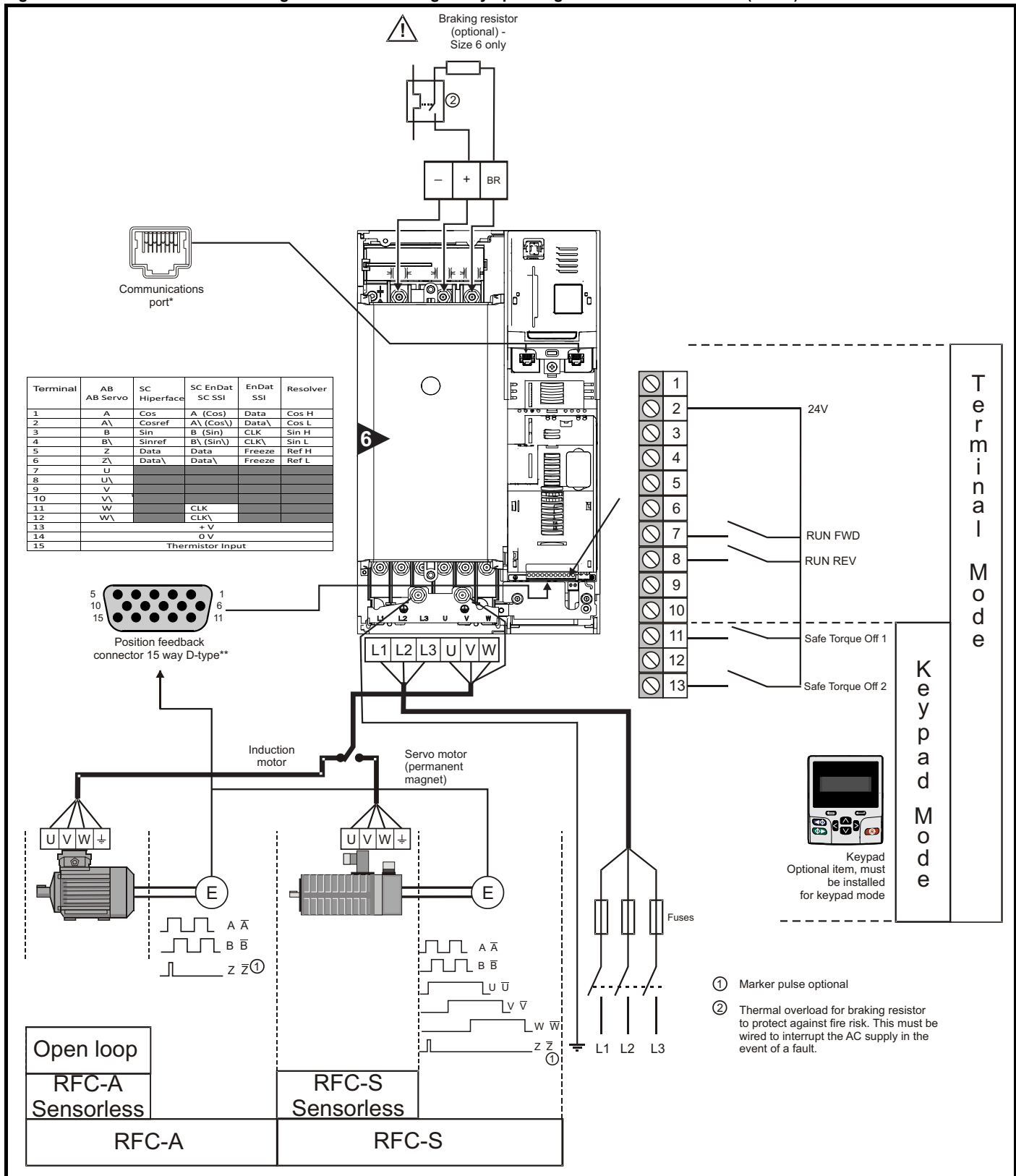

* Ethernet fieldbus communication ports.

** Position feedback port.

Figure 7-7 Minimum connections to get the motor running in any operating mode for Unidrive M700 / M701 (size 7 onwards)

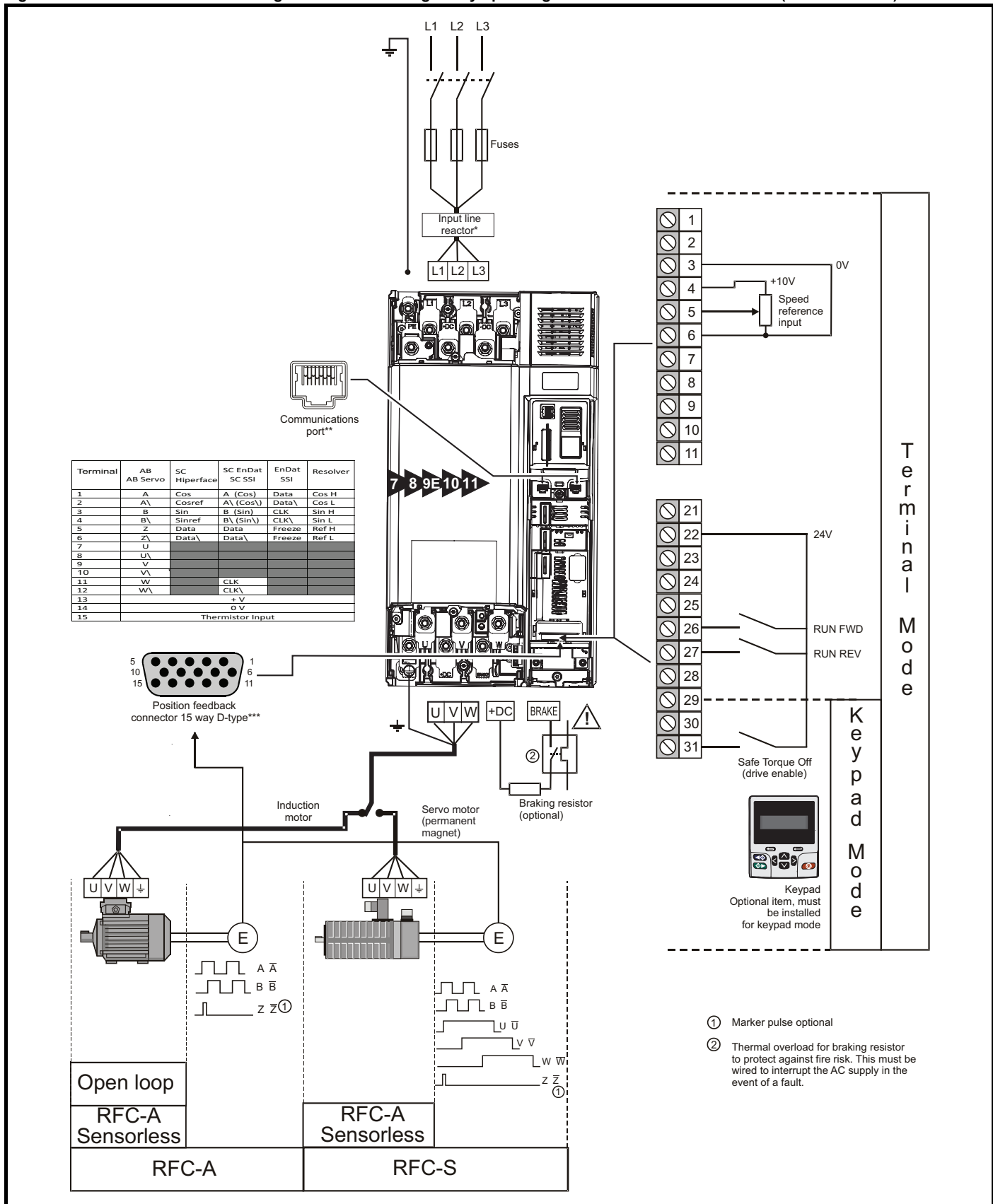

* Required for size 9E, 10 and 11.

** Ethernet fieldbus communication ports on *Unidrive M700* and EIA 485 serial communication ports on *Unidrive M701*.

*** Position feedback port.

Figure 7-8 Minimum connections to get the motor running in any operating mode for Unidrive M702 (size 7 onwards)

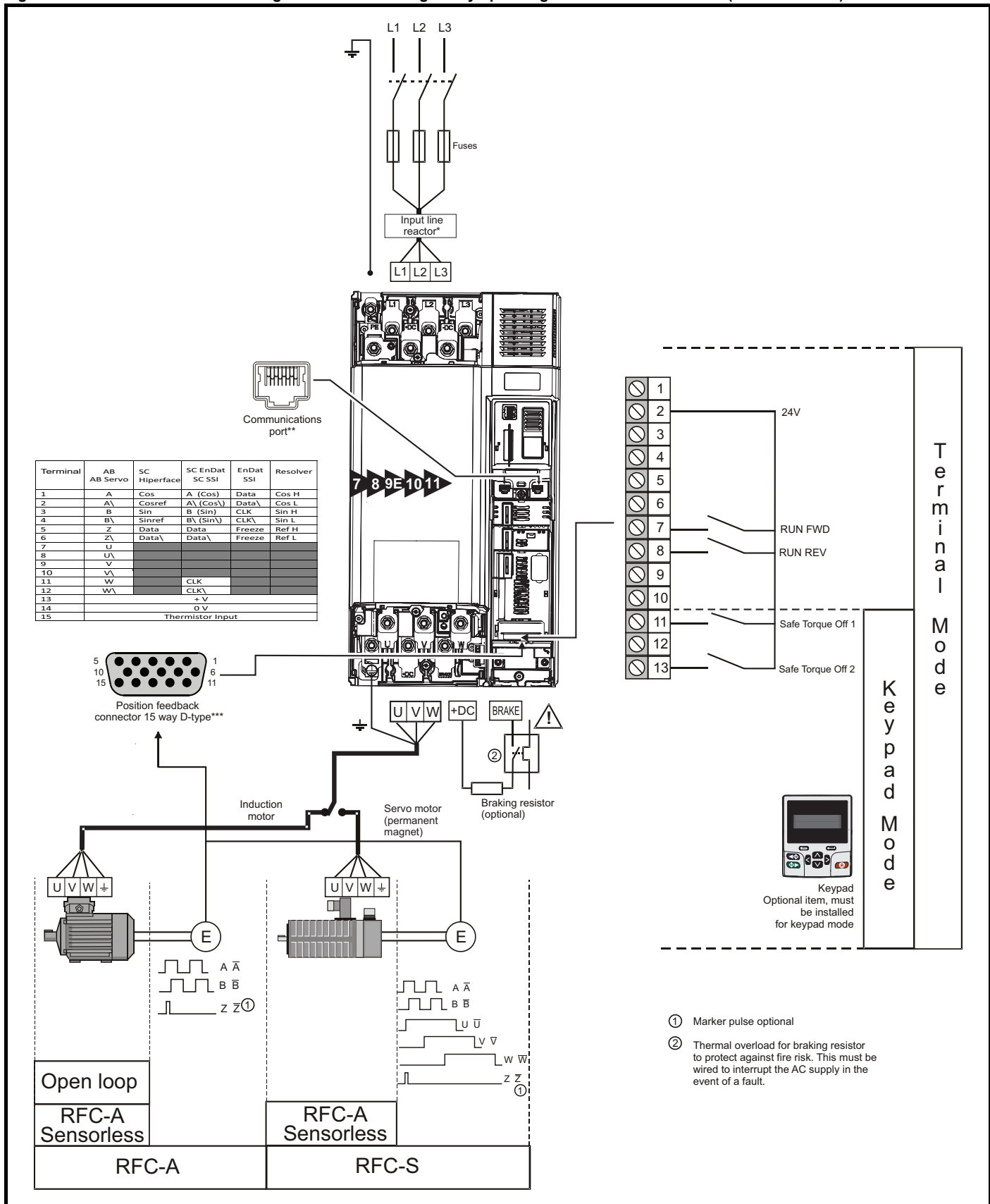

* Required for size 9E, 10 and 11.
 ** Ethernet fieldbus communication ports.
 *** Position feedback port.

Safety information	Product information	Mechanical installation	Electrical installation	Getting started	Basic parameters	Running the motor	Optimization	Drive communication	NV Media Card Operation	Onboard PLC	Advanced parameters	Diagnostics	UL information
--------------------	---------------------	-------------------------	-------------------------	-----------------	------------------	--------------------------	--------------	---------------------	-------------------------	-------------	---------------------	-------------	----------------

7.3 Quick start commissioning / start-up

7.3.1 Open loop









Action	Detail																																					
Before power-up	Ensure: <ul style="list-style-type: none"> The drive enable signal is not given (terminal 31 on Unidrive M700 / M701 and terminal 11 & 13 on Unidrive M702). Run signal is not given Motor is connected 																																					
Power-up the drive	Verify that Open Loop mode is displayed as the drive powers up. If the mode is incorrect see section 5.6 <i>Changing the operating mode</i> on page 45. Ensure: <ul style="list-style-type: none"> Drive displays 'Inhibit' If the drive trips, see section 13 <i>Diagnostics</i> on page 245.																																					
Enter motor nameplate details	Enter: <ul style="list-style-type: none"> Motor rated frequency in Pr 00.047 (Hz) Motor rated current in Pr 00.046 (A) Motor rated speed in Pr 00.045 (rpm) Motor rated voltage in Pr 00.044 (V) - check if Δ or λ connection 	<table border="1"> <tr> <td colspan="2">Mot X XXXXXXXXXX</td> <td colspan="2">No XXXXXXXXXX kg</td> </tr> <tr> <td>IP55</td> <td>I_{cl}F</td> <td>°C</td> <td>s S1</td> </tr> <tr> <td>Δ 230</td> <td>50</td> <td>1445</td> <td>2.20 0.80 8.50</td> </tr> <tr> <td>λ 400</td> <td></td> <td></td> <td>4.90</td> </tr> <tr> <td colspan="4">CN = 14.5Nm</td> </tr> <tr> <td>Δ 240</td> <td>50</td> <td>1445</td> <td>2.20 0.76 8.50</td> </tr> <tr> <td>λ 415</td> <td></td> <td></td> <td>4.90</td> </tr> <tr> <td colspan="4">CN = 14.4Nm</td> </tr> <tr> <td colspan="4">CTP_VEN 1PHASE 1~0.46A P=110W R.F. 32MIN</td> </tr> </table>	Mot X XXXXXXXXXX		No XXXXXXXXXX kg		IP55	I _{cl} F	°C	s S1	Δ 230	50	1445	2.20 0.80 8.50	λ 400			4.90	CN = 14.5Nm				Δ 240	50	1445	2.20 0.76 8.50	λ 415			4.90	CN = 14.4Nm				CTP_VEN 1PHASE 1~0.46A P=110W R.F. 32MIN			
Mot X XXXXXXXXXX		No XXXXXXXXXX kg																																				
IP55	I _{cl} F	°C	s S1																																			
Δ 230	50	1445	2.20 0.80 8.50																																			
λ 400			4.90																																			
CN = 14.5Nm																																						
Δ 240	50	1445	2.20 0.76 8.50																																			
λ 415			4.90																																			
CN = 14.4Nm																																						
CTP_VEN 1PHASE 1~0.46A P=110W R.F. 32MIN																																						
Set maximum frequency	Enter: <ul style="list-style-type: none"> Maximum frequency in Pr 00.002 (Hz) 																																					
Set acceleration / deceleration rates	Enter: <ul style="list-style-type: none"> Acceleration rate in Pr 00.003 (s/100 Hz) Deceleration rate in Pr 00.004 (s/100 Hz) (If braking resistor installed, set Pr 00.015 = Fast. Also ensure Pr 10.030 and Pr 10.031 and Pr 10.061 are set correctly, otherwise premature 'Brake R Too Hot' trips may be seen). 																																					
Motor thermistor set-up	The motor thermistor connection is made through the drive encoder port (terminal 15). The thermistor type is selected in <i>P1 Thermistor Type</i> (03.118). On Unidrive M700 / M701, the motor thermistor can be selected in Pr 07.015 . Refer to Pr 07.015 for further information.																																					
Autotune	<p>The drive is able to perform either a stationary or a rotating autotune. The motor must be at a standstill before an autotune is enabled. A rotating autotune should be used whenever possible so the measured value of power factor of the motor is used by the drive.</p> <div style="border: 1px solid black; padding: 5px;"> <p>WARNING A rotating autotune will cause the motor to accelerate up to $\frac{2}{3}$ base speed in the direction selected regardless of the reference provided. Once complete the motor will coast to a stop. The enable signal must be removed before the drive can be made to run at the required reference.</p> <p>The drive can be stopped at any time by removing the run signal or removing the drive enable.</p> </div> <ul style="list-style-type: none"> A stationary autotune can be used when the motor is loaded and it is not possible to uncouple the load from the motor shaft. A stationary autotune measures the stator resistance and the transient inductance in the motor. These are required for good performance in vector control modes. A stationary autotune does not measure the power factor of the motor so the value on the motor nameplate must be entered into Pr 00.043. A rotating autotune should only be used if the motor is uncoupled. A rotating autotune first performs a stationary autotune before rotating the motor at $\frac{2}{3}$ base speed in the direction selected. The rotating autotune measures the power factor of the motor. To perform an autotune: <ul style="list-style-type: none"> Set Pr 00.040 = 1 for a stationary autotune or set Pr 00.040 = 2 for a rotating autotune Close the Drive Enable signal (terminal 31 on Unidrive M700 / M701 and terminal 11 & 13 on Unidrive M702). The drive will display 'Ready'. Close the run signal (terminal 26 or 27 on Unidrive M700 / M701 and terminal 7 or 8 on Unidrive M702). The upper row of the display will flash 'Auto Tune' while the drive is performing the autotune. Wait for the drive to display 'Ready' or 'Inhibit' and for the motor to come to a standstill. If the drive trips, see Chapter 13 <i>Diagnostics</i> on page 245. <ul style="list-style-type: none"> Remove the drive enable and run signal from the drive. 																																					
Save parameters	Select 'Save Parameters' in Pr mm.000 (alternatively enter a value of 1001 in Pr mm.000) and press the red reset button or toggle the reset digital input.																																					
Run	Drive is now ready to run																																					

Safety information	Product information	Mechanical installation	Electrical installation	Getting started	Basic parameters	Running the motor	Optimization	Drive communication	NV Media Card Operation	Onboard PLC	Advanced parameters	Diagnostics	UL information
--------------------	---------------------	-------------------------	-------------------------	-----------------	------------------	-------------------	--------------	---------------------	-------------------------	-------------	---------------------	-------------	----------------

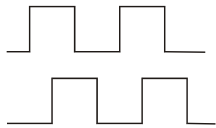
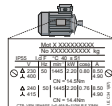
7.3.2 RFC - A mode (with position feedback)

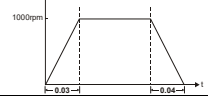

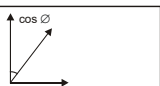
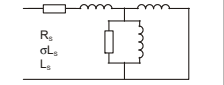
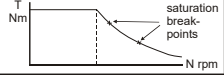

Induction motor with position feedback

For simplicity only an incremental quadrature encoder will be considered here. For information on setting up one of the other supported speed feedback devices, refer to section 7.3.5 *RFC-Sensorless* on page 83.

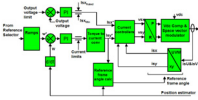
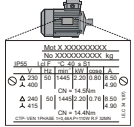
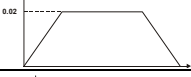
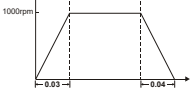

Action	Detail	
Before power-up	Ensure: <ul style="list-style-type: none"> The drive enable signal is not given (terminal 31 on Unidrive M700 / M701 and terminal 11 & 13 on Unidrive M702). Run signal is not given Motor and feedback device are connected 	
Power-up the drive	Verify that RFC-A mode is displayed as the drive powers up. If the mode is incorrect see section 5.6 <i>Changing the operating mode</i> on page 45. Ensure: <ul style="list-style-type: none"> Drive displays 'Inhibit' If the drive trips, see Chapter 13 <i>Diagnostics</i> on page 245.	
Set motor feedback parameters	Incremental encoder basic set-up Enter: <ul style="list-style-type: none"> Drive encoder type in Pr 03.038 = AB (0): Quadrature encoder Encoder power supply in Pr 03.036 = 5 V (0), 8 V (1) or 15 V (2). NOTE If output voltage from the encoder is >5 V, then the termination resistors must be disabled Pr 03.039 to 0.  Setting the encoder voltage supply too high for the encoder could result in damage to the feedback device. CAUTION <ul style="list-style-type: none"> Drive encoder Lines Per Revolution (LPR) in Pr 03.034 (set according to encoder) Drive encoder termination resistor setting in Pr 03.039: <ul style="list-style-type: none"> 0 = A-A\, B-B\, Z-Z\ termination resistors disabled 1 = A-A\, B-B\, termination resistors enabled, Z-Z\ termination resistors disabled 2 = A-A\, B-B\, Z-Z\ termination resistors enabled 	
Enter motor nameplate details	<ul style="list-style-type: none"> Motor rated frequency in Pr 00.047 (Hz) Motor rated current in Pr 00.046 (A) Motor rated speed in Pr 00.045 (rpm) Motor rated voltage in Pr 00.044 (V) - check if Δ or Y connection 	
Set maximum speed	Enter: Maximum speed in Pr 00.002 (rpm)	
Set acceleration / deceleration rates	Enter: <ul style="list-style-type: none"> Acceleration rate in Pr 00.003 (s/1000 rpm) Deceleration rate in Pr 00.004 (s/1000 rpm) (If braking resistor installed, set Pr 00.015 = Fast. Also ensure Pr 10.030, Pr 10.031 and Pr 10.061 are set correctly, otherwise premature 'Brake R Too Hot' trips may be seen). 	
Motor thermistor set-up	The motor thermistor connection is made through the drive encoder port (terminal 15). The thermistor type is selected in <i>P1 Thermistor Type</i> (03.118). On Unidrive M700 / M701, the motor thermistor can be selected in Pr 07.015 . Refer to Pr 07.015 for further information.	
Autotune	The drive is able to perform either a stationary or a rotating autotune. The motor must be at a standstill before an autotune is enabled. A stationary autotune will give moderate performance whereas a rotating autotune will give improved performance as it measures the actual values of the motor parameters required by the drive.  A rotating autotune will cause the motor to accelerate up to $\frac{2}{3}$ base speed in the direction selected regardless of the reference provided. Once complete the motor will coast to a stop. The enable signal must be removed before the drive can be made to run at the required reference. The drive can be stopped at any time by removing the run signal or removing the drive enable. <ul style="list-style-type: none"> A stationary autotune can be used when the motor is loaded and it is not possible to uncouple the load from the motor shaft. The stationary autotune measures the stator resistance and transient inductance of the motor. These are used to calculate the current loop gains, and at the end of the test the values in Pr 00.038 and Pr 00.039 are updated. A stationary autotune does not measure the power factor of the motor so the value on the motor nameplate must be entered into Pr 00.043. A rotating autotune should only be used if the motor is uncoupled. A rotating autotune first performs a stationary autotune before rotating the motor at $\frac{2}{3}$ base speed in the direction selected. The rotating autotune measures the stator inductance of the motor and calculates the power factor. To perform an autotune: <ul style="list-style-type: none"> Set Pr 00.040 = 1 for a stationary autotune or set Pr 00.040 = 2 for a rotating autotune Close the drive enable signal (terminal 31 on Unidrive M700 / M701 and terminal 11 & 13 on Unidrive M702). The drive will display 'Ready'. Close the run signal (terminal 26 or 27 on Unidrive M700 / M701 and terminal 7 or 8 on Unidrive M702). The upper row of the display will flash 'Auto Tune' while the drive is performing the autotune. Wait for the drive to display 'Ready' or 'Inhibit' and for the motor to come to a standstill. If the drive trips, see Chapter 13 <i>Diagnostics</i> on page 245. Remove the drive enable and run signal from the drive. 	  
Save parameters	Select 'Save Parameters' in Pr mm.000 (alternatively enter a value of 1001 in Pr mm.000) and press red 	
Run	Drive is now ready to run	

Safety information	Product information	Mechanical installation	Electrical installation	Getting started	Basic parameters	Running the motor	Optimization	Drive communication	NV Media Card Operation	Onboard PLC	Advanced parameters	Diagnostics	UL information
--------------------	---------------------	-------------------------	-------------------------	-----------------	------------------	--------------------------	--------------	---------------------	-------------------------	-------------	---------------------	-------------	----------------

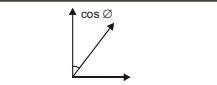
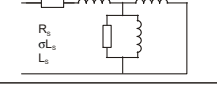
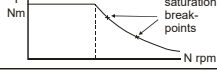
7.3.3 RFC-A mode (Sensorless control) Induction motor with sensorless control

Action	Detail	
Before power-up	Ensure: <ul style="list-style-type: none"> The drive enable signal is not given (terminal 31 on Unidrive M700 / M701 and terminal 11 & 13 on Unidrive M702). Run signal is not given Motor is connected 	
Power-up the drive	Verify that RFC-A mode is displayed as the drive powers up. If the mode is incorrect see section 5.6 <i>Changing the operating mode</i> on page 45. Ensure: <ul style="list-style-type: none"> Drive displays 'Inhibit' If the drive trips, see Chapter 13 <i>Diagnostics</i> on page 245.	
Select RFC-A (Sensorless control) mode and disable encoder wire-break trip	<ul style="list-style-type: none"> Set Pr 03.024 = 1 or 3 to select RFC-A Sensorless mode Set Pr 03.040 = 0000 to disable the wire break 	
Enter motor nameplate details	Enter: <ul style="list-style-type: none"> Motor rated frequency in Pr 00.047 (Hz) Motor rated current in Pr 00.046 (A) Motor rated speed in Pr 00.045 (rpm) Motor rated voltage in Pr 00.044 (V) - check if Δ or Y connection 	
Set maximum speed	Enter: <ul style="list-style-type: none"> Maximum speed in Pr 00.002 (rpm) 	
Set acceleration / deceleration rates	Enter: <ul style="list-style-type: none"> Acceleration rate in Pr 00.003 (s/1000rpm) Deceleration rate in Pr 00.004 (s/1000rpm) (If braking resistor installed, set Pr 00.015 = Fast. Also ensure Pr 10.030, Pr 10.031 and Pr 10.061 are set correctly, otherwise premature 'Brake R Too Hot' trips may be seen). 	
Motor thermistor set-up	The motor thermistor connection is made through the drive encoder port (terminal 15). The thermistor type is selected in <i>P1 Thermistor Type</i> (03.118). On Unidrive M700 / M701, the motor thermistor can be selected in Pr 07.015 . Refer to Pr 07.015 for further information.	
Select or deselect catch a spinning motor mode	If catch a spinning motor mode is not required then set Pr 06.009 to 0. If catch a spinning motor mode is required then leave Pr 06.009 at the default of 1, but depending on the size of the motor the value in Pr 05.040 may need to be adjusted. Pr 05.040 defines a scaling function used by the algorithm that detects the speed of the motor. The default value of Pr 05.040 is 1 which is suitable for small motors (<4 kW). For larger motors the value in Pr 05.040 will need to be increased. Approximate values of Pr 05.040 for different motor sizes are as follows, 2 for 11 kW, 3 for 55 kW and 5 for 150 kW. If the value of Pr 05.040 is too large the motor may accelerate from standstill when the drive is enabled. If the value of this parameter is too small the drive will detect the motor speed as zero even if the motor is spinning.	
Autotune	<p>The drive is able to perform either a stationary or a rotating autotune. The motor must be at a standstill before an autotune is enabled. A stationary autotune will give moderate performance whereas a rotating autotune will give improved performance as it measures the actual values of the motor parameters required by the drive.</p> <p>NOTE It is highly recommended that a rotating autotune is performed (Pr 00.040 set to 2).</p> <div style="border: 1px solid black; padding: 5px; margin: 10px 0;">  <p>A rotating autotune will cause the motor to accelerate up to $2/3$ base speed in the direction selected regardless of the reference provided. Once complete the motor will coast to a stop. The enable signal must be removed before the drive can be made to run at the required reference. The drive can be stopped at any time by removing the run signal or removing the drive enable.</p> </div> <ul style="list-style-type: none"> A stationary autotune can be used when the motor is loaded and it is not possible to uncouple the load from the motor shaft. The stationary autotune measures the stator resistance and transient inductance of the motor. These are used to calculate the current loop gains, and at the end of the test the values in Pr 00.038 and Pr 00.039 are updated. A stationary autotune does not measure the power factor of the motor so the value on the motor nameplate must be entered into Pr 00.043. A rotating autotune should only be used if the motor is uncoupled. A rotating autotune first performs a stationary autotune before rotating the motor at $2/3$ base speed in the direction selected. The rotating autotune measures the stator inductance of the motor and calculates the power factor. <p>To perform an autotune:</p> <ul style="list-style-type: none"> Set Pr 00.040 = 1 for a stationary autotune or set Pr 00.040 = 2 for a rotating autotune Close the drive enable signal (terminal 31 on Unidrive M700 / M701 and terminal 11 & 13 on Unidrive M702). The drive will display 'Ready' or 'Inhibit'. Close the run signal (terminal 26 or 27 on Unidrive M700 / M701 and terminal 7 or 8 on Unidrive M702). The upper row of the display will flash 'Auto Tune' while the drive is performing the autotune. Wait for the drive to display 'Ready' or 'Inhibit' and for the motor to come to a standstill. <p>If the drive trips, see Chapter 13 <i>Diagnostics</i> on page 245.</p> <ul style="list-style-type: none"> Remove the drive enable and run signal from the drive. 	  



Safety information	Product information	Mechanical installation	Electrical installation	Getting started	Basic parameters	Running the motor	Optimization	Drive communication	NV Media Card Operation	Onboard PLC	Advanced parameters	Diagnostics	UL information
--------------------	---------------------	-------------------------	-------------------------	-----------------	------------------	--------------------------	--------------	---------------------	-------------------------	-------------	---------------------	-------------	----------------

Action	Detail
Save parameters	Select 'Save Parameters' in Pr MM.000 (alternatively enter a value of 1001 in Pr MM.000) and press red  reset button or toggle the reset digital input.
Run	Drive is now ready to run 



7.3.4 RFC-S mode (with position feedback)

Permanent magnet motor with position feedback

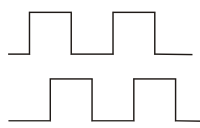
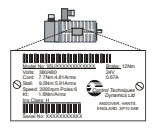
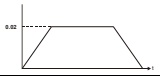
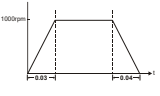
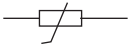
For simplicity only an incremental quadrature encoder with commutation outputs will be considered here. For information on setting up one of the other supported speed feedback devices, refer to section 7.3.5 *RFC-Sensorless* on page 83.

Action	Detail
Before power-up	Ensure: <ul style="list-style-type: none"> The drive enable signal is not given (terminal 31 on Unidrive M700 / M701 and terminal 11 & 13 on Unidrive M702). Run signal is not given Motor and feedback device are connected 
Power-up the drive	Verify that RFC-S mode is displayed as the drive powers up. If the mode is incorrect see section 5.6 <i>Changing the operating mode</i> on page 45. Ensure: <ul style="list-style-type: none"> Drive displays 'inhibit' If the drive trips, see Chapter 13 <i>Diagnostics</i> on page 245. 
Set motor feedback parameters	Incremental encoder basic set-up Enter: <ul style="list-style-type: none"> Drive encoder type in Pr 03.038 = AB Servo (3): Quadrature encoder with commutation outputs Encoder power supply in Pr 03.036 = 5 V (0), 8 V (1) or 15 V (2). NOTE If output voltage from the encoder is >5 V, then the termination resistors must be disabled Pr 03.039 to 0. <div style="border: 1px solid black; padding: 5px; margin: 10px 0;">  <p>Setting the encoder voltage supply too high for the encoder could result in damage to the feedback device.</p> <p>CAUTION</p> </div>  <ul style="list-style-type: none"> Drive encoder Pulses Per Revolution in Pr 03.034 (set according to encoder) Drive encoder termination resistor setting in Pr 03.039: <ul style="list-style-type: none"> 0 = A-A\, B-B\, Z-Z\ termination resistors disabled 1 = A-A\, B-B\, termination resistors enabled, Z-Z\ termination resistors disabled 2 = A-A\, B-B\, Z-Z\ termination resistors enabled
Enter motor nameplate details	Enter: <ul style="list-style-type: none"> Motor rated current in Pr 00.046 (A) Ensure that this equal to or less than the Heavy Duty rating of the drive otherwise 'Motor Too Hot' trips may occur during the autotune. <ul style="list-style-type: none"> Number of poles in Pr 00.042 Motor rated voltage in Pr 00.044 (V) 
Set maximum speed	Enter: <ul style="list-style-type: none"> Maximum speed in Pr 00.002 (rpm) 
Set acceleration / deceleration rates	Enter: <ul style="list-style-type: none"> Acceleration rate in Pr 00.003 (s/1000 rpm) Deceleration rate in Pr 00.004 (s/1000 rpm) (If braking resistor installed, set Pr 00.015 = Fast. Also ensure Pr 10.030, Pr 10.031 and Pr 10.061 are set correctly, otherwise premature 'Brake R Too Hot' trips may be seen). 
Motor thermistor set-up	The motor thermistor connection is made through the drive encoder port (terminal 15). The thermistor type is selected in <i>P1 Thermistor Type</i> (03.118). On Unidrive M700 / M701, the motor thermistor can be selected in Pr 07.015 . Refer to Pr 07.015 for further information. 

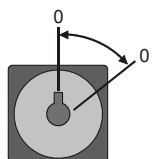
Safety information	Product information	Mechanical installation	Electrical installation	Getting started	Basic parameters	Running the motor	Optimization	Drive communication	NV Media Card Operation	Onboard PLC	Advanced parameters	Diagnostics	UL information
--------------------	---------------------	-------------------------	-------------------------	-----------------	------------------	--------------------------	--------------	---------------------	-------------------------	-------------	---------------------	-------------	----------------

Action	Detail	
Autotune	<p>The drive is able to perform either a stationary or a rotating autotune. The motor must be at a standstill before an autotune is enabled. A stationary autotune will give moderate performance whereas a rotating autotune will give improved performance as it measures the actual values of the motor parameters required by the drive. The drive is able to perform a stationary, rotating, mechanical load measurement or locked rotor test autotune. The motor must be at a standstill before an autotune is enabled. It is suggested that a rotating auto tune is used for accurate measurement for position feedback phase angle.</p> <ul style="list-style-type: none"> A stationary autotune can be used when the motor is loaded and it is not possible to uncouple the load from the motor shaft. A stationary autotune is performed to locate the flux axis of the motor. The stationary autotune measures the stator resistance, inductance in flux axis, maximum deadtime compensation, inductance in torque axis with no load on the motor and current at maximum deadtime compensation of the motor. These are used to calculate the current loop gains, and at the end of the test the values in Pr 00.038 and Pr 00.039 are updated. If Sensorless mode is not selected then <i>Position Feedback Phase Angle</i> (00.043) is set-up for the selected position feedback. A rotating autotune should only be used if the motor is uncoupled. The rotating autotune will rotate the motor by up to 2 mechanical revolutions in the direction selected, regardless of the reference provided to obtain the position feedback phase angle. A stationary autotune is then performed to obtain stator resistance, inductance in flux axis, maximum deadtime compensation, inductance in torque axis with no load on the motor and current at maximum deadtime compensation of the motor. From the above obtained parameters the current loop gains are calculated, and at the end of the test the values in Pr 00.038 and Pr 00.039 are updated. <div style="border: 1px solid black; padding: 5px;">  <p>The rotating autotune will rotate the motor by up to 2 mechanical revolutions in the direction selected, regardless of the reference provided. After a short delay, the motor is further rotated through a electrical revolution. The enable signal must be removed before the drive can be made to run at the required reference. The drive can be stopped at any time by removing the run signal or removing the drive enable.</p> </div> <p>To perform an autotune:</p> <ul style="list-style-type: none"> Set Pr 00.040 = 1 for a stationary autotune, Pr 00.040 = 2 for a rotating autotune. Close the run signal (terminal 26 or 27 on Unidrive M700 / M701 and terminal 7 or 8 on Unidrive M702). Close the drive enable signal (terminal 31 on Unidrive M700 / M701 and terminal 11 & 13 on Unidrive M702). The upper row of the display will flash 'Auto Tune' while the drive is performing the test. Wait for the drive to display 'Ready' or 'Inhibit' and for the motor to come to a standstill. <p>If the drive trips it cannot be reset until the drive enable signal (terminal 31 on Unidrive M700 / M701 and terminal 11 & 13 on Unidrive M702) has been removed. See section 13 <i>Diagnostics</i> on page 245.</p> <ul style="list-style-type: none"> Remove the drive enabled and run signal from the drive. 	
Save parameters	Select 'Save Parameters' in Pr MM.000 (alternatively enter a value of 1001 in Pr MM.000) and press red 	
Run	Drive is now ready to run	

Safety information	Product information	Mechanical installation	Electrical installation	Getting started	Basic parameters	Running the motor	Optimization	Drive communication	NV Media Card Operation	Onboard PLC	Advanced parameters	Diagnostics	UL information
--------------------	---------------------	-------------------------	-------------------------	-----------------	------------------	--------------------------	--------------	---------------------	-------------------------	-------------	---------------------	-------------	----------------

7.3.5 RFC-Sensorless

Permanent magnet motor without position feedback

Action	Detail	
Before power-up	<p>Ensure:</p> <ul style="list-style-type: none"> The drive enable signal is not given (terminal 31 on Unidrive M700/M701 and terminal 11 & 13 on Unidrive M702). Run signal is not given Motor is connected 	
Power-up the drive	<p>Verify that RFC-S mode is displayed as the drive powers up. If the mode is incorrect see section 5.6 <i>Changing the operating mode</i> on page 45, otherwise restore parameter defaults (see section 5.8 <i>Restoring parameter defaults</i> on page 45).</p> <p>Ensure:</p> <ul style="list-style-type: none"> Drive displays 'inhibit' <p>If the drive trips, see Chapter 13 <i>Diagnostics</i> on page 245.</p>	
Enter motor nameplate details	<p>Enter:</p> <ul style="list-style-type: none"> Motor rated current in Pr 00.046 (A) <p>Ensure that this equal to or less than the Heavy Duty rating of the drive otherwise 'Motor Too Hot' trips may occur during the autotune.</p> <ul style="list-style-type: none"> Number of poles in Pr 00.042 Motor rated voltage in Pr 00.044 (V) 	
Set maximum speed	<p>Enter:</p> <ul style="list-style-type: none"> Maximum speed in Pr 00.002 (rpm) 	
Set acceleration / deceleration rates	<p>Enter:</p> <ul style="list-style-type: none"> Acceleration rate in Pr 00.003 (s/1000 rpm). It is recommended that the ramp rates are increased from the default value of 0.200 s/1000 rpm. Deceleration rate in Pr 00.004 (s/1000 rpm) (If braking resistor installed, set Pr 00.015 = Fast. Also ensure Pr 10.030, Pr 10.031 and Pr 10.061 are set correctly, otherwise premature 'Brake R Too Hot' trips may be seen). 	
Set stop mode	<p>Enter:</p> <ul style="list-style-type: none"> Set Stop Mode to Ramp in Pr 06.001 	
Set hold zero speed	<p>Enter:</p> <ul style="list-style-type: none"> Set Hold Zero Speed to Off (0) in Pr 06.008. 	
Autotune	<p>The drive is able to perform a stationary autotune. The motor must be at a standstill before an autotune is enabled. A stationary autotune will give moderate performance.</p> <ul style="list-style-type: none"> A stationary autotune is performed to locate the flux axis of the motor. The stationary autotune measures the stator resistance, inductance in flux axis, inductance in torque axis with no load on the motor and values relating to deadtime compensation from the drive. Measured values are used to calculate the current loop gains, and at the end of the test the values in Pr 00.038 and Pr 00.039 are updated. <p>To perform an autotune:</p> <ul style="list-style-type: none"> Set Pr 00.040 = 1 or 2 for a stationary autotune. (Both perform the same tests). Close the run signal (terminal 26 or 27 on Unidrive M700/M701 and terminal 7 or 8 on Unidrive M702). Close the drive enable signal (terminal 31 on Unidrive M700/M701 and terminal 11 & 13 on Unidrive M702). The upper row of the display will flash 'Auto Tune' while the drive is performing the test. Wait for the drive to display 'Ready' or 'Inhibit' and for the motor to come to a standstill. <p>If the drive trips it cannot be reset until the drive enable signal (terminal 31) has been removed. See Chapter 13 <i>Diagnostics</i> on page 245.</p> <ul style="list-style-type: none"> Remove the drive enabled and run signal from the drive. 	
Check Saliency	<p>In sensorless mode, when the motor speed is below Pr 00.045 / 10, a special low speed algorithm must be used to control the motor. There are two modes available, with the mode chosen based on the saliency of the motor.</p> <p>The ratio No-load Lq (Pr 00.056) / Ld (Pr 05.024) provides a measure of the saliency. If this value is > 1.1, then Injection (0) mode may be used. Current (2) mode may be used (but with limitations). If this value is < 1.1, then Current (2) mode must be used (this is the default of Pr 05.064).</p>	
Save parameters	<p>Select 'Save Parameters' in Pr mm.000 (alternatively enter a value of 1001 in Pr mm.000) and press red </p> <p>reset button or toggle the reset digital input.</p>	
Run	<p>Drive is now ready to run</p>	

Safety information	Product information	Mechanical installation	Electrical installation	Getting started	Basic parameters	Running the motor	Optimization	Drive communication	NV Media Card Operation	Onboard PLC	Advanced parameters	Diagnostics	UL information
--------------------	---------------------	-------------------------	-------------------------	-----------------	------------------	-------------------	--------------	---------------------	-------------------------	-------------	---------------------	-------------	----------------

7.4 Setting up a feedback device

7.4.1 P1 position interface

This section shows the parameter settings which must be made to use each of the compatible feedback device types with P1 position interface on the drive. For more information on the parameters listed here please refer to the *Parameter Reference Guide*.

Table 7-3 Parameters required for feedback device set-up on the P1 position interface

Parameter	AB, FD, FR, AB Servo, FD Servo, FR Servo, SC, SC Servo	SC Hiperface	SC EnDat	EnDat	SC SSI	SSI	SC BiSS	BiSS	Resolver
P1 Marker Mode (03.031)	✓								
P1 Rotary Turns Bits (03.033)		●	●	●	✓	✓	✓	✓	
P1 Rotary Lines Per Revolution (03.034)	✓	●	●		✓		✓		
P1 Comms Bits (03.035)		●	●	●	✓	✓	✓	✓	
P1 Supply Voltage (03.036)*	✓	✓	✓	✓	✓	✓	✓	✓	
P1 Comms Baud Rate (03.037)			✓	✓	✓	✓	✓	✓	
P1 Device Type (03.038)	✓	✓	✓	✓	✓	✓	✓	✓	✓
P1 Auto-configuration Select (03.041)		✓	✓	✓					
P1 SSI Binary Mode (03.048)					✓	✓	✓	✓	
P1 Resolver Poles (03.065)									✓
P1 Resolver Excitation (03.066)									✓
P1 Additional Configuration (03.074)							✓	✓	

- ✓ Information required to be entered by the user.
- Parameter can be set-up automatically by the drive through auto-configuration parameter. Must be set by the user if auto-configuration is disabled (i.e. Pr 03.041 = Disabled (0)).

* Pr 03.036: If the output voltage from the encoder is >5 V, then termination resistors must be disabled by setting Pr 03.039 to 0.

Table 7-3 shows a summary of the parameters required to set-up each feedback device. More detailed information follows.

7.4.2 P1 position interface: Detailed feedback device commissioning / start-up information

Standard quadrature encoder with or without commutation signals (A, B, Z or A, B, Z, U, V, W), or Sincos encoder with or without UVW commutation signals																														
Device Type (03.038)	AB (0) for a quadrature encoder without commutation signals * AB Servo (3) for a quadrature encoder with commutation signals SC (6) for a Sincos encoder without commutation signals * SC Servo (12) for a Sincos encoder with commutation signals																													
Supply Voltage (03.036)	5 V (0), 8 V (1) or 15 V (2) NOTE If output voltage from the encoder is >5 V, then the termination resistors must be disabled. Set Pr 03.039 to 0																													
Rotary Line Per Revolution (03.034)	Set to the number of lines or sine waves per revolution of the encoder.																													
Termination Select (03.039) (AB or AB Servo only)	0 = A, B, Z termination resistors disabled 1 = A, B termination resistors enabled and Z termination resistors disabled 2 = A, B, Z termination resistors enabled																													
Marker Mode (03.031)	<table border="1"> <thead> <tr> <th colspan="4">Bit</th> <th rowspan="2">Description</th> </tr> <tr> <th>3</th> <th>2</th> <th>1</th> <th>0</th> </tr> </thead> <tbody> <tr> <td>x</td> <td>x</td> <td>x</td> <td>1</td> <td>No action is taken unless marker flag is zero before marker event occurs</td> </tr> <tr> <td>x</td> <td>x</td> <td>1</td> <td>x</td> <td>Pr 03.028 and Pr 03.058 are set to zero</td> </tr> <tr> <td>x</td> <td>1</td> <td>x</td> <td>x</td> <td>Pr 03.028, Pr 03.029, Pr 03.030 and the related part of Pr 03.058 are not reset. Pr 03.058 is transferred to Pr 03.059 and Pr 03.032 is set to 1.</td> </tr> <tr> <td>1</td> <td>x</td> <td>x</td> <td>x</td> <td>Undefined state region range is reduced from -30 mV to 30 mV. The marker pulse is only recognized if the pulse is 10 μs wide.</td> </tr> </tbody> </table>	Bit				Description	3	2	1	0	x	x	x	1	No action is taken unless marker flag is zero before marker event occurs	x	x	1	x	Pr 03.028 and Pr 03.058 are set to zero	x	1	x	x	Pr 03.028, Pr 03.029, Pr 03.030 and the related part of Pr 03.058 are not reset. Pr 03.058 is transferred to Pr 03.059 and Pr 03.032 is set to 1.	1	x	x	x	Undefined state region range is reduced from -30 mV to 30 mV. The marker pulse is only recognized if the pulse is 10 μs wide.
Bit				Description																										
3	2	1	0																											
x	x	x	1	No action is taken unless marker flag is zero before marker event occurs																										
x	x	1	x	Pr 03.028 and Pr 03.058 are set to zero																										
x	1	x	x	Pr 03.028, Pr 03.029, Pr 03.030 and the related part of Pr 03.058 are not reset. Pr 03.058 is transferred to Pr 03.059 and Pr 03.032 is set to 1.																										
1	x	x	x	Undefined state region range is reduced from -30 mV to 30 mV. The marker pulse is only recognized if the pulse is 10 μs wide.																										
Error Detection Level (03.040)	<table border="1"> <thead> <tr> <th colspan="4">Bit</th> <th rowspan="2">Description</th> </tr> <tr> <th>3</th> <th>2</th> <th>1</th> <th>0</th> </tr> </thead> <tbody> <tr> <td>x</td> <td>x</td> <td>x</td> <td>1</td> <td>Enable wire break detection</td> </tr> <tr> <td>1</td> <td>x</td> <td>x</td> <td>x</td> <td>Disable trips Encoder 1 to Encoder 6</td> </tr> </tbody> </table>	Bit				Description	3	2	1	0	x	x	x	1	Enable wire break detection	1	x	x	x	Disable trips Encoder 1 to Encoder 6										
Bit				Description																										
3	2	1	0																											
x	x	x	1	Enable wire break detection																										
1	x	x	x	Disable trips Encoder 1 to Encoder 6																										

* These settings should only be used in RFC-A mode. If used in RFC-S mode a phase offset test must be performed after every power up.

Safety information	Product information	Mechanical installation	Electrical installation	Getting started	Basic parameters	Running the motor	Optimization	Drive communication	NV Media Card Operation	Onboard PLC	Advanced parameters	Diagnostics	UL information
--------------------	---------------------	-------------------------	-------------------------	-----------------	------------------	-------------------	--------------	---------------------	-------------------------	-------------	---------------------	-------------	----------------

Incremental encoder with Frequency and Direction (F and D) or Forward and Reverse (CW and CCW) signals with or without commutation signals.

<i>Device Type (03.038)</i>	FD (1) for frequency and direction signals without commutation signals* FR (3) for forward and reverse signals without commutation signals* FD Servo (4) for frequency and direction signals with commutation signals FR Servo (5) for forward and reverse signals with commutation signals																													
<i>Supply Voltage (03.036)</i>	5 V (0), 8 V (1) or 15 V (2) NOTE If output voltage from the encoder is >5 V, then the termination resistors must be disabled. Set Pr 03.039 to 0																													
<i>Rotary Line Per Revolution (03.034)</i>	Set to the number of pulses per revolution of the encoder divided by 2.																													
<i>Termination Select (03.039)</i>	0 = F or CW, D or CCW, Z termination resistors disabled 1 = F or CW, D or CCW termination resistors enabled and Z termination resistors disabled 2 = For CW, D or CCW, Z termination resistors enabled																													
<i>Marker Mode (03.031)</i>	<table border="1"> <thead> <tr> <th colspan="4">Bit</th> <th rowspan="2">Description</th> </tr> <tr> <th>3</th> <th>2</th> <th>1</th> <th>0</th> </tr> </thead> <tbody> <tr> <td>x</td> <td>x</td> <td>x</td> <td>1</td> <td>No action is taken unless marker flag is zero before marker event occurs</td> </tr> <tr> <td>x</td> <td>x</td> <td>1</td> <td>x</td> <td>Pr 03.028 and Pr 03.058 are set to zero</td> </tr> <tr> <td>x</td> <td>1</td> <td>x</td> <td>x</td> <td>Pr 03.028, Pr 03.029, Pr 03.030 and the related part of Pr 03.058 are not reset. Pr 03.058 is transferred to Pr 03.059 and Pr 03.032 is set to 1.</td> </tr> <tr> <td>1</td> <td>x</td> <td>x</td> <td>x</td> <td>Undefined state region range is reduced from -30 mV to 30 mV. The marker pulse is only recognized if the pulse is 10 μs wide.</td> </tr> </tbody> </table>	Bit				Description	3	2	1	0	x	x	x	1	No action is taken unless marker flag is zero before marker event occurs	x	x	1	x	Pr 03.028 and Pr 03.058 are set to zero	x	1	x	x	Pr 03.028 , Pr 03.029 , Pr 03.030 and the related part of Pr 03.058 are not reset. Pr 03.058 is transferred to Pr 03.059 and Pr 03.032 is set to 1.	1	x	x	x	Undefined state region range is reduced from -30 mV to 30 mV. The marker pulse is only recognized if the pulse is 10 μs wide.
Bit				Description																										
3	2	1	0																											
x	x	x	1	No action is taken unless marker flag is zero before marker event occurs																										
x	x	1	x	Pr 03.028 and Pr 03.058 are set to zero																										
x	1	x	x	Pr 03.028 , Pr 03.029 , Pr 03.030 and the related part of Pr 03.058 are not reset. Pr 03.058 is transferred to Pr 03.059 and Pr 03.032 is set to 1.																										
1	x	x	x	Undefined state region range is reduced from -30 mV to 30 mV. The marker pulse is only recognized if the pulse is 10 μs wide.																										
<i>Error Detection Level (03.040)</i>	<table border="1"> <thead> <tr> <th colspan="4">Bit</th> <th rowspan="2">Description</th> </tr> <tr> <th>3</th> <th>2</th> <th>1</th> <th>0</th> </tr> </thead> <tbody> <tr> <td>x</td> <td>x</td> <td>x</td> <td>1</td> <td>Enable wire break detection</td> </tr> <tr> <td>1</td> <td>x</td> <td>x</td> <td>x</td> <td>Disable trips <i>Encoder 1 to Encoder 7</i></td> </tr> </tbody> </table>	Bit				Description	3	2	1	0	x	x	x	1	Enable wire break detection	1	x	x	x	Disable trips <i>Encoder 1 to Encoder 7</i>										
Bit				Description																										
3	2	1	0																											
x	x	x	1	Enable wire break detection																										
1	x	x	x	Disable trips <i>Encoder 1 to Encoder 7</i>																										

* These settings should only be used in RFC-A mode. If used in RFC-S mode a phase offset test must be performed after every power up.

Absolute Sincos encoder with Hiperface or EnDat serial communication, or Absolute EnDat communication only encoder

<i>Device Type (03.038)</i>	SC Hiperface (7) for a Sincos encoder with Hiperface serial communications EnDat (8) for an EnDat communications only encoder SC EnDat (9) for a Sincos encoder with EnDat serial communications																								
<i>Supply Voltage (03.036)</i>	5 V (0), 8 V (1) or 15 V (2)																								
<i>Auto-configuration Select (03.041)</i>	Auto-configuration is enabled at default and automatically sets up the following parameters. <i>Rotary Turns Bits (03.033)</i> <i>Rotary Lines Per Revolutions (03.034)</i> <i>Comms Bits (03.035)</i> These parameters can be entered manually when Pr 03.041 is set to Disabled (0).																								
<i>Comms Baud Rate (03.037)</i>	100 k, 200 k, 300 k, 400 k, 500 k, 1 M, 1.5 M, 2 M, 4 M																								
<i>Error Detection Level (03.040)</i>	<table border="1"> <thead> <tr> <th colspan="4">Bit</th> <th rowspan="2">Description</th> </tr> <tr> <th>3</th> <th>2</th> <th>1</th> <th>0</th> </tr> </thead> <tbody> <tr> <td>x</td> <td>x</td> <td>x</td> <td>1</td> <td>Enable wire break detection</td> </tr> <tr> <td>x</td> <td>x</td> <td>1</td> <td>x</td> <td>Enable phase error detection</td> </tr> <tr> <td>1</td> <td>x</td> <td>x</td> <td>x</td> <td>Disable trips <i>Encoder 1 to Encoder 6</i></td> </tr> </tbody> </table> <p>So for example, to enable the wire break and phase error detection, set Pr 03.040 to 0011.</p>	Bit				Description	3	2	1	0	x	x	x	1	Enable wire break detection	x	x	1	x	Enable phase error detection	1	x	x	x	Disable trips <i>Encoder 1 to Encoder 6</i>
Bit				Description																					
3	2	1	0																						
x	x	x	1	Enable wire break detection																					
x	x	1	x	Enable phase error detection																					
1	x	x	x	Disable trips <i>Encoder 1 to Encoder 6</i>																					

Absolute SSI communications only encoder, or Absolute Sincos encoder with SSI communications

<i>Device Type (03.038)</i>	SSI (10) for a SSI communications only encoder SC SSI (11) for a Sincos encoder with SSI serial communications
<i>Supply Voltage (03.036)</i>	5 V (0), 8 V (1) or 15 V (2)
<i>Rotary Line Per Revolution (03.034)</i>	Set the number of sine waves per revolution of the encoder
<i>SSI Binary Mode (03.048)</i>	Off = Gray Code On = Binary Mode
<i>Rotary Turns Bits (03.033)</i>	Set to the number of turns bits for the encoder (this is normally 12 bits for a SSI encoder)
<i>Comms Bits (03.035)</i>	Total number of bits of position information (this is usually 25 bits for a SSI encoder)
<i>Comms Baud Rate (03.037)</i>	100 k, 200 k, 300 k, 400 k, 500 k, 1 M, 1.5 M, 2 M, 4 M

<i>Error Detection Level (03.040)</i>	<table border="1"> <thead> <tr> <th colspan="4">Bit</th> <th rowspan="2">Description</th> </tr> <tr> <th>3</th> <th>2</th> <th>1</th> <th>0</th> </tr> </thead> <tbody> <tr> <td>x</td> <td>x</td> <td>x</td> <td>1</td> <td>Enable wire break detection</td> </tr> <tr> <td>x</td> <td>x</td> <td>1</td> <td>x</td> <td>Enable phase error detection</td> </tr> <tr> <td>x</td> <td>1</td> <td>x</td> <td>x</td> <td>Enable SSI power supply alarm bit monitor</td> </tr> <tr> <td>1</td> <td>x</td> <td>x</td> <td>x</td> <td>Disable trips <i>Encoder 1 to Encoder 6</i></td> </tr> </tbody> </table>	Bit				Description	3	2	1	0	x	x	x	1	Enable wire break detection	x	x	1	x	Enable phase error detection	x	1	x	x	Enable SSI power supply alarm bit monitor	1	x	x	x	Disable trips <i>Encoder 1 to Encoder 6</i>
	Bit				Description																									
	3	2	1	0																										
	x	x	x	1	Enable wire break detection																									
	x	x	1	x	Enable phase error detection																									
x	1	x	x	Enable SSI power supply alarm bit monitor																										
1	x	x	x	Disable trips <i>Encoder 1 to Encoder 6</i>																										
So for example, to enable the wire break and phase error detection, set Pr 03.040 to 0011.																														

Safety information	Product information	Mechanical installation	Electrical installation	Getting started	Basic parameters	Running the motor	Optimization	Drive communication	NV Media Card Operation	Onboard PLC	Advanced parameters	Diagnostics	UL information
--------------------	---------------------	-------------------------	-------------------------	-----------------	------------------	--------------------------	--------------	---------------------	-------------------------	-------------	---------------------	-------------	----------------

UVW commutation signal only encoders*

<i>Device Type (03.038)</i>	Commutation Only (16) for a quadrature encoder with commutation signals*
<i>Supply Voltage (03.036)</i>	5 V (0), 8 V (1) or 15 V (2)
<i>Error Detection Level (03.040)</i>	Set to zero to disable wire break detection

* This feedback device provides very low resolution feedback and should not be used for applications requiring a high level of performance. Due to the low resolution of UVW communication only encoders, it is recommended that the *P1 Feedback Filter (03.042)* is set to its maximum value. A value of 1 ms to 2 ms may also be required in the *Current Reference Filter (00.017)* and it is also recommended that the speed loop gains are set to a low value to obtain stable operation.

Resolver

<i>Device Type (03.038)</i>	Resolver (14)
<i>Resolver Poles (03.065)</i>	Set number of Resolver poles 2 poles (1) to 20 poles (10)
<i>Resolver Excitation (03.066)</i>	Set Resolver excitation voltage and frequency 6kHz 3V (0), 8kHz 3V (1), 6kHz 2V (2), 8kHz 2V (3)

<i>Error Detection Level (03.040)</i>	Bit				Description
	3	2	1	0	
	x	x	x	1	Enable wire break detection
	1	x	x	x	Disable trips <i>Encoder 1 to Encoder 6</i>

So for example, to enable the wire break error detection, set Pr **03.040** to 0001.

Safety information	Product information	Mechanical installation	Electrical installation	Getting started	Basic parameters	Running the motor	Optimization	Drive communication	NV Media Card Operation	Onboard PLC	Advanced parameters	Diagnostics	UL information
--------------------	---------------------	-------------------------	-------------------------	-----------------	------------------	-------------------	--------------	---------------------	-------------------------	-------------	---------------------	-------------	----------------

7.4.3 P2 position interface

This section shows the parameter settings which must be made to use each of the compatible feedback device types with the P2 position interface on the drive. For more information on the parameters listed here please refer to the *Parameter Reference Guide*. If the position feedback device connected to the P2 position interface is required to be used for motor control feedback then Pr **03.026** will need to be set to P2 Drive (1).

Table 7-4 Parameters required for feedback device set-up on the P2 position interface

Parameter	AB, FD, FR	EnDat	SSI	BISS
P2 Marker Mode (03.131)	✓			
P2 Rotary Turns Bits (03.133)		●	●	✓
P2 Rotary Lines Per Revolution (03.134)	✓			
P2 Comms Bits (03.135)		●	●	✓
P2 Comms Baud Rate (03.137)		✓	✓	✓
P2 Device Type (03.138)	✓	✓	✓	✓
P2 Auto-configuration Select (03.141)		✓		
P2 Additional Configuration (03.174)				✓

- ✓ Information required to be entered by the user.
- Parameter can be set-up automatically by the drive through auto-configuration. Parameter must be set by the user if auto-configuration is disabled (i.e. Pr **03.141** = Disabled (0)).

The P2 position interface does not have its own independent power supply output. Therefore, any position feedback device connected to the P2 position interface must either share the P1 power supply output on pin 13 of the 15-way D-type, or be supplied from an external source.

NOTE

The termination resistors are always enabled on the P2 position interface. Wire break detection is not available when using AB, FD or FR position feedback device types on the P2 position interface.

Table 7-4 shows a summary of the parameters required to set-up each feedback device. More detailed information follows.

Standard quadrature encoder (A, B, Z)																														
Device Type (03.138)	AB (1) for a quadrature encoder																													
Rotary Line Per Revolution (03.134)	Set to the number of lines per revolution of the encoder																													
Marker Mode (03.131)	<table border="1"> <thead> <tr> <th colspan="4">Bit</th> <th rowspan="2">Description</th> </tr> <tr> <th>3</th> <th>2</th> <th>1</th> <th>0</th> </tr> </thead> <tbody> <tr> <td>x</td> <td>x</td> <td>x</td> <td>1</td> <td>No action is taken unless marker flag is zero before marker event occurs</td> </tr> <tr> <td>x</td> <td>x</td> <td>1</td> <td>x</td> <td>Pr 03.128 and Pr 03.158 are set to zero</td> </tr> <tr> <td>x</td> <td>1</td> <td>x</td> <td>x</td> <td>Pr 03.128, Pr 03.129, Pr 03.130 and the related part of Pr 03.158 are not reset. Pr 03.158 is transferred to Pr 03.159 and Pr 03.132 is set to 1.</td> </tr> <tr> <td>1</td> <td>x</td> <td>x</td> <td>x</td> <td>This Bit in has no effect.</td> </tr> </tbody> </table>	Bit				Description	3	2	1	0	x	x	x	1	No action is taken unless marker flag is zero before marker event occurs	x	x	1	x	Pr 03.128 and Pr 03.158 are set to zero	x	1	x	x	Pr 03.128 , Pr 03.129 , Pr 03.130 and the related part of Pr 03.158 are not reset. Pr 03.158 is transferred to Pr 03.159 and Pr 03.132 is set to 1.	1	x	x	x	This Bit in has no effect.
	Bit				Description																									
	3	2	1	0																										
	x	x	x	1	No action is taken unless marker flag is zero before marker event occurs																									
	x	x	1	x	Pr 03.128 and Pr 03.158 are set to zero																									
x	1	x	x	Pr 03.128 , Pr 03.129 , Pr 03.130 and the related part of Pr 03.158 are not reset. Pr 03.158 is transferred to Pr 03.159 and Pr 03.132 is set to 1.																										
1	x	x	x	This Bit in has no effect.																										

Incremental encoder with Frequency and Direction (F and D), or Forward and Reverse (CW and CCW) signals																														
Device Type (03.138)	FD (2) for frequency and direction signals without commutation signals FR (3) for forward and reverse signals without commutation signals																													
Rotary Line Per Revolution (03.134)	Set to the number of pulses per revolution of the encoder divided by 2																													
Marker Mode (03.131)	<table border="1"> <thead> <tr> <th colspan="4">Bit</th> <th rowspan="2">Description</th> </tr> <tr> <th>3</th> <th>2</th> <th>1</th> <th>0</th> </tr> </thead> <tbody> <tr> <td>x</td> <td>x</td> <td>x</td> <td>1</td> <td>No action is taken unless marker flag is zero before marker event occurs</td> </tr> <tr> <td>x</td> <td>x</td> <td>1</td> <td>x</td> <td>Pr 03.128 and Pr 03.158 are set to zero</td> </tr> <tr> <td>x</td> <td>1</td> <td>x</td> <td>x</td> <td>Pr 03.128, Pr 03.129, Pr 03.130 and the related part of Pr 03.158 are not reset. Pr 03.158 is transferred to Pr 03.159 and Pr 03.132 is set to 1.</td> </tr> <tr> <td>1</td> <td>x</td> <td>x</td> <td>x</td> <td>This Bit in has no effect.</td> </tr> </tbody> </table>	Bit				Description	3	2	1	0	x	x	x	1	No action is taken unless marker flag is zero before marker event occurs	x	x	1	x	Pr 03.128 and Pr 03.158 are set to zero	x	1	x	x	Pr 03.128 , Pr 03.129 , Pr 03.130 and the related part of Pr 03.158 are not reset. Pr 03.158 is transferred to Pr 03.159 and Pr 03.132 is set to 1.	1	x	x	x	This Bit in has no effect.
	Bit				Description																									
	3	2	1	0																										
	x	x	x	1	No action is taken unless marker flag is zero before marker event occurs																									
	x	x	1	x	Pr 03.128 and Pr 03.158 are set to zero																									
x	1	x	x	Pr 03.128 , Pr 03.129 , Pr 03.130 and the related part of Pr 03.158 are not reset. Pr 03.158 is transferred to Pr 03.159 and Pr 03.132 is set to 1.																										
1	x	x	x	This Bit in has no effect.																										

Absolute EnDat communication only encoder															
<i>Device Type (03.138)</i>	EnDat (4) for an EnDat communications only encoder														
<i>Auto-configuration Select (03.141)</i>	Auto-configuration is enabled at default and automatically sets up the following parameters: <i>Rotary Turns Bits (03.133)</i> <i>Comms Bits (03.135)</i> These parameters can be entered manually when Pr 03.141 is set to Disabled (0).														
<i>Comms Baud Rate (03.137)</i>	100 k, 200 k, 300 k, 400 k, 500 k, 1 M, 1.5 M, 2 M, 4 M														
<i>Error Detection Level (03.140)</i>	<table border="1"> <thead> <tr> <th colspan="4">Bit</th> <th rowspan="2">Description</th> </tr> <tr> <th>3</th> <th>2</th> <th>1</th> <th>0</th> </tr> </thead> <tbody> <tr> <td>1</td> <td>x</td> <td>x</td> <td>x</td> <td>Disable trips <i>Encoder 4 to Encoder 6</i></td> </tr> </tbody> </table>	Bit				Description	3	2	1	0	1	x	x	x	Disable trips <i>Encoder 4 to Encoder 6</i>
Bit				Description											
3	2	1	0												
1	x	x	x	Disable trips <i>Encoder 4 to Encoder 6</i>											

Absolute SSI communications only encoder																				
<i>Device Type (03.138)</i>	SSI (5) for a SSI communications only encoder																			
<i>SSI Binary Mode (03.148)</i>	Off (0) = Gray Code On (1) = Binary Mode																			
<i>Rotary Turns Bits (03.133)</i>	Set to the number of turns bits for the encoder (this is usually 12 bits for a multi-turn SSI encoder)																			
<i>Comms Bits (03.135)</i>	Total number of bits of position information for the encoder (this is usually 25 bits for a multi-turn SSI encoder)																			
<i>Comms Baud Rate (03.137)</i>	100 k, 200 k, 300 k, 400 k, 500 k, 1 M, 1.5 M, 2 M, 4 M																			
<i>Error Detection Level (03.140)</i>	<table border="1"> <thead> <tr> <th colspan="4">Bit</th> <th rowspan="2">Description</th> </tr> <tr> <th>3</th> <th>2</th> <th>1</th> <th>0</th> </tr> </thead> <tbody> <tr> <td>x</td> <td>1</td> <td>x</td> <td>x</td> <td><i>Enable SSI power supply alarm bit monitor</i></td> </tr> <tr> <td>1</td> <td>x</td> <td>x</td> <td>x</td> <td>Disable trips <i>Encoder 4 to Encoder 6</i></td> </tr> </tbody> </table>	Bit				Description	3	2	1	0	x	1	x	x	<i>Enable SSI power supply alarm bit monitor</i>	1	x	x	x	Disable trips <i>Encoder 4 to Encoder 6</i>
Bit				Description																
3	2	1	0																	
x	1	x	x	<i>Enable SSI power supply alarm bit monitor</i>																
1	x	x	x	Disable trips <i>Encoder 4 to Encoder 6</i>																

Safety information	Product information	Mechanical installation	Electrical installation	Getting started	Basic parameters	Running the motor	Optimization	Drive communication	NV Media Card Operation	Onboard PLC	Advanced parameters	Diagnostics	UL information
--------------------	---------------------	-------------------------	-------------------------	-----------------	------------------	--------------------------	--------------	---------------------	-------------------------	-------------	---------------------	-------------	----------------

7.5 Encoder Simulation Output Set-up

The drive supports four modes of encoder simulation output.

- Hardware mode - Incremental signals (AB, FD, FR)
- Software mode - Incremental signals (AB, FD, FR)
- Software mode - Ratio
- Software mode - Absolute SSI data

The availability of the encoder simulation output on the 15-way D-type on the drive is dependent on the type of feedback device connected to the P1 position interface. See Table 4-9 on page 32 for more information on the availability of the encoder simulation output. The status of the encoder simulation output can be seen in *Encoder Simulation Status* (03.086) as follows:

- None (0) The encoder simulation output is not enabled or is not available
- Full (1) Full encoder simulation with marker output is available
- No Marker (2) Encoder simulation without marker output is available

This section shows the parameter settings which must be made to use the encoder simulation output on the drive. For more information on the parameters listed here please refer to the Parameter Reference Guide.

7.5.1 Hardware mode - Incremental signals (AB, FD, or FR)

Hardware mode provides incremental signals derived via hardware from the P1 position feedback interface on the drive, with negligible delay. The supported incremental output signals are AB, FD and FR. Hardware mode only produces an output when the input device connected to the P1 position interface is AB, FD, FR, SC, SC Hiperface, SC EnDat or SC SSI type devices. It should be noted that with a SINCOS source device the output is based on the zero crossings of the sine wave inputs and does not include interpolation.

Hardware mode set-up	
<i>Encoder Simulation Source</i> (03.085)	This parameter must be set to 03.029 to select the P1 position interface as the source.
<i>Encoder Simulation Mode</i> (03.088)	Set to a value of Hardware (0)
<i>Encoder Simulation Hardware Divider</i> (03.089)	This parameter defines the divider ratio between the device connected to the P1 position feedback interface and the output. 0 = 1/1 1 = 1/2 2 = 1/4 3 = 1/8 4 = 1/16 5 = 1/32 6 = 1/64 7 = 1/128
<i>Encoder Simulation Hardware Marker Lock</i> (03.090)	0 = The marker output is derived directly from the marker input 1 = The incremental output signals are adjusted on each marker event so that the A and B are high with an AB type output, or F is high with an FD or FR type output
<i>Encoder Simulation Output Mode</i> (03.098)	AB/Gray (0) for a AB quadrature output signals FD/Binary (1) for Frequency and Direction output signals FR/Binary (2) for Forward and Reverse output signals

7.5.2 Software mode - Incremental signals (AB, FD, or FR)

In software mode the encoder simulation output is derived via software from the selected source with a minimum delay of 250 μ s which may be extended with *Encoder Simulation Sample Period* (03.087). For incremental output signals, the resolution of the output can be defined by either selecting the required output lines per revolution or by an output ratio.

Lines per revolution

The output resolution of the encoder simulation output is defined by *Encoder Simulation Output Lines Per Revolution* (03.092).

AB quadrature output signals, software mode setup – Lines per revolution	
<i>Encoder Simulation Source</i> (03.085)	Set to the parameter number of the position source Pr 03.029 to use the P1 position interface on the drive as the source. Pr 03.129 to use the P2 position interface on the drive as the source. This parameter can be set to any other valid position reference generated by the drive or an option module.
<i>Encoder Simulation Mode</i> (03.088)	Set to a value of Lines Per Rev (1)
<i>Encoder Simulation Output Lines Per Revolution</i> (03.092)	Set to the required output lines per revolution. The maximum output lines per revolution are 16384.
<i>Encoder Simulation Output Mode</i> (03.098)	AB/Gray (0) for a AB quadrature output signals

Safety information	Product information	Mechanical installation	Electrical installation	Getting started	Basic parameters	Running the motor	Optimization	Drive communication	NV Media Card Operation	Onboard PLC	Advanced parameters	Diagnostics	UL information
--------------------	---------------------	-------------------------	-------------------------	-----------------	------------------	--------------------------	--------------	---------------------	-------------------------	-------------	---------------------	-------------	----------------

Frequency and Direction or Forward and Reverse output signals, software mode setup – Lines per revolution

<i>Encoder Simulation Source (03.085)</i>	Set to the parameter number of the position source Pr 03.029 to use the P1 position interface on the drive as the source. Pr 03.129 to use the P2 position interface on the drive as the source. This parameter can be set to any other valid position reference generated by the drive or an option module.
<i>Encoder Simulation Mode (03.088)</i>	Set to a value of Lines Per Rev (1)
<i>Encoder Simulation Output Lines Per Revolution (03.092)</i>	Set to the required output pulse per revolution divided by 2. For example if 2000 pulses per revolution is required, set this parameter to 1000.
<i>Encoder Simulation Output Mode (03.098)</i>	FD/Binary (1) for Frequency and Direction output signals FR/Binary (2) for Forward and Reverse output signals

Safety information	Product information	Mechanical installation	Electrical installation	Getting started	Basic parameters	Running the motor	Optimization	Drive communication	NV Media Card Operation	Onboard PLC	Advanced parameters	Diagnostics	UL information
--------------------	---------------------	-------------------------	-------------------------	-----------------	------------------	--------------------------	--------------	---------------------	-------------------------	-------------	---------------------	-------------	----------------

Ratio

In ratio mode the resolution of the input source is based on a 16 bit position feedback device (i.e. equivalent to an AB quadrature encoder with a resolution of 16384 lines per revolution). The output resolution of the encoder simulation output is defined by the ratio of *Encoder Simulation Numerator* (03.093) and *Encoder Simulation Denominator* (03.094).

AB quadrature output signals, software mode setup – Ratio Frequency and Direction or Forward and Reverse output signals, software mode setup

<i>Encoder Simulation Source</i> (03.085)	Set to the parameter number of the position source Pr 03.029 to use the P1 position interface on the drive as the source. Pr 03.129 to use the P2 position interface on the drive as the source. This parameter can be set to any other valid position reference generated by the drive or an option module.
<i>Encoder Simulation Mode</i> (03.088)	Set to a value of Ratio (2)
<i>Encoder Simulation Numerator</i> (03.093) and <i>Encoder Simulation Denominator</i> (03.094)	Set these two parameters to give the required output ratio.
<i>Encoder Simulation Output Mode</i> (03.098)	AB/Gray (0) for a AB quadrature output signals FD/Binary (1) for Frequency and Direction output signals FR/Binary (2) for Forward and Reverse output signals

Software mode - Absolute SSI data

In software mode the encoder simulation output is derived via software from the selected source with a minimum delay of 250 μ s which may be extended with *Encoder Simulation Sample Period* (03.087). In SSI output mode drive will simulate an SSI encoder, where the number of bits and the format of the position message can be adjusted.

Absolute SSI data, software mode setup

<i>Encoder Simulation Source</i> (03.085)	Set to the parameter number of the position source Pr 03.029 to use the P1 position interface on the drive as the source. Pr 03.129 to use the P2 position interface on the drive as the source. This parameter can be set to any other valid position reference generated by the drive or an option module.
<i>Encoder Simulation Mode</i> (03.088)	Set to a value of SSI (3)
<i>Encoder Simulation SSI Turns Bits</i> (03.096)	Set to the number of bits representing the number of turns in the position message.
<i>Encoder Simulation SSI Comms Bits</i> (03.097)	Set to the number bits in the whole position message.
<i>Encoder Simulation Output Mode</i> (03.098)	AB/Gray (0) for position data in Gray code format FD/Binary (1) or FR/Binary (2) for position data in binary format

Safety information	Product information	Mechanical installation	Electrical installation	Getting started	Basic parameters	Running the motor	Optimization	Drive communication	NV Media Card Operation	Onboard PLC	Advanced parameters	Diagnostics	UL information
--------------------	---------------------	-------------------------	-------------------------	-----------------	------------------	-------------------	---------------------	---------------------	-------------------------	-------------	---------------------	-------------	----------------

8 Optimization

This chapter takes the user through methods of optimizing the drive set-up and maximize the performance. The auto-tuning features of the drive simplify the optimization tasks.

8.1 Motor map parameters

8.1.1 Open loop motor control

Pr 00.046 {05.007} Rated Current	Defines the maximum continuous motor current
<ul style="list-style-type: none"> The rated current parameter must be set to the maximum continuous current of the motor. (See section 8.2 <i>Maximum motor rated current</i> on page 108, for information about setting this parameter higher than the maximum Heavy Duty current rating). The motor rated current is used in the following: <ul style="list-style-type: none"> Current limits (see section 8.3 <i>Current limits</i> on page 108, for more information) Motor thermal overload protection (see section 8.4 <i>Motor thermal protection</i> on page 108, for more information) Vector mode voltage control (see <i>Open Loop Control Mode</i> (00.007), later in this table) Slip compensation (see <i>Enable Slip Compensation</i> (05.027), later in this table) Dynamic V/F control 	
Pr 00.044 {05.009} Rated Voltage	Defines the voltage applied to the motor at rated frequency
Pr 00.047 {05.006} Rated Frequency	Defines the frequency at which rated voltage is applied
<p>The <i>Rated Voltage</i> (00.044) and the <i>Rated Frequency</i> (00.047) are used to define the voltage to frequency characteristic applied to the motor (see <i>Open Loop Control Mode</i> (00.007), later in this table). The <i>Rated Frequency</i> (00.047) is also used in conjunction with the motor rated speed to calculate the rated slip for slip compensation (see <i>Rated Speed</i> (00.045), later in this table).</p>	
Pr 00.045 {05.008} Rated Speed	Defines the full load rated speed of the motor
Pr 00.042 {05.011} Number Of Motor Poles	Defines the number of motor poles
<p>The motor rated speed and the number of poles are used with the motor rated frequency to calculate the rated slip of induction machines in Hz.</p> $\text{Rated slip (Hz)} = \text{Motor rated frequency} - (\text{Number of pole pairs} \times [\text{Motor rated speed} / 60]) = \mathbf{00.047} = \left(\frac{\mathbf{00.042}}{2} \times \frac{\mathbf{00.045}}{60} \right)$ <p>If Pr 00.045 is set to 0 or to synchronous speed, slip compensation is disabled. If slip compensation is required this parameter should be set to the nameplate value, which should give the correct rpm for a hot machine. Sometimes it will be necessary to adjust this when the drive is commissioned because the nameplate value may be inaccurate. Slip compensation will operate correctly both below base speed and within the field-weakening region. Slip compensation is normally used to correct for the motor speed to prevent speed variation with load. The rated load rpm can be set higher than synchronous speed to deliberately introduce speed droop. This can be useful to aid load sharing with mechanically coupled motors.</p> <p>Pr 00.042 is also used in the calculation of the motor speed display by the drive for a given output frequency. When Pr 00.042 is set to 'Automatic', the number of motor poles is automatically calculated from the rated frequency Pr 00.047, and the motor rated speed Pr 00.045.</p> $\text{Number of poles} = 120 \times (\text{Rated Frequency} (00.047) / \text{Rated Speed} (00.045)) \text{ rounded to the nearest even number.}$	
Pr 00.043 {05.010} Rated Power Factor	Defines the angle between the motor voltage and current
<p>The power factor is the true power factor of the motor, i.e. the angle between the motor voltage and current. The power factor is used in conjunction with the <i>Rated Current</i> (00.046), to calculate the rated active current and magnetising current of the motor. The rated active current is used extensively to control the drive, and the magnetising current is used in vector mode stator resistance compensation. It is important that this parameter is set up correctly. The drive can measure the motor rated power factor by performing a rotating autotune (see <i>Autotune</i> (Pr 00.040), overleaf).</p>	

Safety information	Product information	Mechanical installation	Electrical installation	Getting started	Basic parameters	Running the motor	Optimization	Drive communication	NV Media Card Operation	Onboard PLC	Advanced parameters	Diagnostics	UL information
--------------------	---------------------	-------------------------	-------------------------	-----------------	------------------	-------------------	---------------------	---------------------	-------------------------	-------------	---------------------	-------------	----------------

Pr 00.040 {05.012} Autotune

There are two autotune tests available in open loop mode, a stationary and a rotating test. A rotating autotune should be used whenever possible so the measured value of power factor of the motor is used by the drive.

- A stationary autotune can be used when the motor is loaded and it is not possible to remove the load from the motor shaft. The stationary test measures the *Stator Resistance* (05.017), *Transient Inductance* (05.024), *Maximum Deadtime Compensation* (05.059) and *Current At Maximum Deadtime Compensation* (05.060) which are required for good performance in vector control modes (see *Open Loop Control Mode* (00.007), later in this table). The stationary autotune does not measure the power factor of the motor so the value on the motor nameplate must be entered into Pr **00.043**. To perform a Stationary autotune, set Pr **00.040** to 1, and provide the drive with both an enable signal (terminal 31 on Unidrive M700 / M701 and terminal 11 & 13 on Unidrive M702) and a run signal (terminal 26 or 27 on Unidrive M700 / M701 and terminal 7 or 8 on Unidrive M702).
- A rotating autotune should only be used if the motor is unloaded. A rotating autotune first performs a stationary autotune, as above, then a rotating test is performed in which the motor is accelerated with currently selected ramps up to a frequency of *Rated Frequency* (05.006) x 2/3, and the frequency is maintained at that level for 4 seconds. *Stator Inductance* (05.025) is measured and this value is used in conjunction with other motor parameters to calculate *Rated Power Factor* (05.010). To perform a Rotating autotune, set Pr **00.040** to 2, and provide the drive with both an enable signal (terminal 31 on Unidrive M700 / M701 and terminal 11 & 13 on Unidrive M702) and a run signal (terminal 26 or 27 on Unidrive M700 / M701 and terminal 7 or 8 on Unidrive M702).

Following the completion of an autotune test the drive will go into the inhibit state. The drive must be placed into a controlled disable condition before the drive can be made to run at the required reference. The drive can be put in to a controlled disable condition by removing the Safe Torque Off signal from terminal 31 on *Unidrive M700 / M701* and terminal 11 & 13 on *Unidrive M702*, setting the *Drive Enable* (06.015) to OFF (0) or disabling the drive via the *Control Word* (06.042) and *Control Word Enable* (06.043).

Pr 00.007 {05.014} Open Loop Control Mode

There are several voltage modes available which fall into two categories, vector control and fixed boost.

Vector control

Vector control mode provides the motor with a linear voltage characteristic from 0 Hz to motor *Rated Frequency* (00.047), and then a constant voltage above motor rated frequency. When the drive operates between motor rated frequency/50 and motor rated frequency/4, full vector based stator resistance compensation is applied. When the drive operates between motor rated frequency/4 and motor rated frequency/2 the stator resistance compensation is gradually reduced to zero as the frequency increases. For the vector modes to operate correctly the *Rated Power Factor* (00.043), *Stator Resistance* (05.017) are all required to be set up accurately. The drive can be made to measure these by performing an autotune (see Pr 00.040 *Autotune*). The drive can also be made to measure the stator resistance automatically every time the drive is enabled or the first time the drive is enabled after it is powered up, by selecting one of the vector control voltage modes.

(0) **Ur S** = The stator resistance is measured and the parameter for the selected motor map is over-written each time the drive is made to run. This test can only be done with a stationary motor where the flux has decayed to zero. Therefore this mode should only be used if the motor is guaranteed to be stationary each time the drive is made to run. To prevent the test from being done before the flux has decayed there is a period of 1 second after the drive has been in the ready state during which the test is not done if the drive is made to run again. In this case, previously measured values are used. Ur S mode ensures that the drive compensates for any change in motor parameters due to changes in temperature. The new value of stator resistance is not automatically saved to the drive's EEPROM.

(1) **Ur** = The stator resistance is not measured. The user can enter the motor and cabling resistance into the *Stator Resistance* (05.017). However this will not include resistance effects within the drive inverter. Therefore if this mode is to be used, it is best to use an autotune test initially to measure the stator resistance.

(3) **Ur_Auto** = The stator resistance is measured once, the first time the drive is made to run. After the test has been completed successfully the *Open Loop Control Mode* (00.007) is changed to Ur mode. The *Stator Resistance* (05.017) parameter is written to, and along with the *Open Loop Control Mode* (00.007), are saved in the drive's EEPROM. If the test fails, the voltage mode changes to Ur mode but *Stator Resistance* (05.017) is not updated.

(4) **Ur I** = The stator resistance is measured when the drive is first made to run after each power-up. This test can only be done with a stationary motor. Therefore this mode should only be used if the motor is guaranteed to be stationary the first time the drive is made to run after each power-up. The new value of stator resistance is not automatically saved to the drive's EEPROM.

Pr 00.007 {05.014} Open Loop Control Mode (cont)

Fixed boost

The stator resistance is not used in the control of the motor, instead a fixed characteristic with low frequency voltage boost as defined by parameter Pr 00.008, is used. Fixed boost mode should be used when the drive is controlling multiple motors. There are two settings of fixed boost available:
 (2) **Fixed** = This mode provides the motor with a linear voltage characteristic from 0 Hz to *Rated Frequency* (00.047), and then a constant voltage above rated frequency.

(5) **Square** = This mode provides the motor with a square law voltage characteristic from 0 Hz to *Rated Frequency* (00.047), and then a constant voltage above rated frequency. This mode is suitable for variable torque applications like fans and pumps where the load is proportional to the square of the speed of the motor shaft. This mode should not be used if a high starting torque is required.

For both these modes, at low frequencies (from 0Hz to 1/2 x Pr 00.047) a voltage boost is applied defined by Pr 00.008 as shown below:

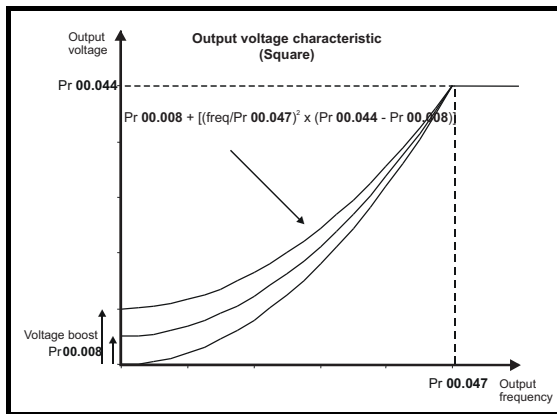
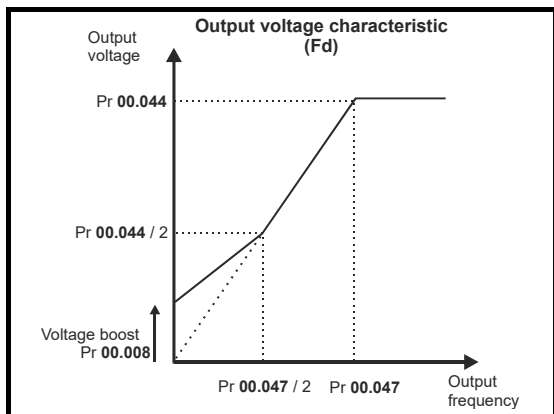

Pr 05.027 Enable Slip Compensation

When a motor, being controlled in open loop mode, has load applied a characteristic of the motor is that the output speed droops in proportion to the load applied as shown:

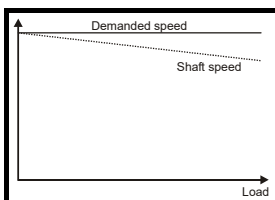

In order to prevent the speed droop shown above slip compensation should be enabled. To enable slip compensation Pr 05.027 must be set to a 1 (this is the default setting), and the motor rated speed must be entered in Pr 00.045 (Pr 05.008).

The motor rated speed parameter should be set to the synchronous speed of the motor minus the slip speed. This is normally displayed on the motor nameplate, i.e. for a typical 18.5 kW, 50 Hz, 4 pole motor, the motor rated speed would be approximately 1465 rpm. The synchronous speed for a 50 Hz, 4 pole motor is 1500 rpm, so therefore the slip speed would be 35 rpm. If the synchronous speed is entered in Pr 00.045, slip compensation will be disabled. If too small a value is entered in Pr 00.045, the motor will run faster than the demanded frequency. The synchronous speeds for 50 Hz motors with different numbers of poles are as follows:

2 pole = 3000 rpm, 4 pole = 1500 rpm, 6 pole = 1000 rpm, 8 pole = 750 rpm

Safety information	Product information	Mechanical installation	Electrical installation	Getting started	Basic parameters	Running the motor	Optimization	Drive communication	NV Media Card Operation	Onboard PLC	Advanced parameters	Diagnostics	UL information
--------------------	---------------------	-------------------------	-------------------------	-----------------	------------------	-------------------	---------------------	---------------------	-------------------------	-------------	---------------------	-------------	----------------

8.1.2 RFC-A mode

Induction motor with Position feedback

Pr 00.046 {05.007} Motor Rated Current	Defines the maximum motor continuous current
<p>The motor rated current parameter must be set to the maximum continuous current of the motor. (See section 8.2 <i>Maximum motor rated current</i> on page 108, for information about setting this parameter higher than the maximum Heavy Duty current rating.) The motor rated current is used in the following:</p> <ul style="list-style-type: none"> • Current limits (see section 8.3 <i>Current limits</i> on page 108, for more information). • Motor thermal overload protection (see section 8.4 <i>Motor thermal protection</i> on page 108, for more information) • Vector control algorithm 	
Pr 00.044 {05.009} Rated Voltage	Defines the voltage applied to the motor at rated frequency
Pr 00.047 {05.006} Rated Frequency	Defines the frequency at which rated voltage is applied
<p>The <i>Rated Voltage</i> (00.044) and the <i>Rated Frequency</i> (00.047) are used to define the voltage to frequency characteristic applied to the motor (see <i>Open Loop Control Mode</i> (00.007), later in this table). The motor rated frequency is also used in conjunction with the motor rated speed to calculate the rated slip for slip compensation (see motor <i>Rated Speed</i> (00.045), later in this table).</p>	
<p>The graph, titled 'Output voltage characteristic', plots Output voltage on the vertical axis against Output frequency on the horizontal axis. A solid line starts at the origin (0,0) and rises linearly to a point where the frequency is labeled 'Pr 00.047' and the voltage is 'Pr 00.044'. From this point, the line becomes horizontal, indicating constant output voltage. A dashed line from the point (Pr 00.047 / 2, Pr 00.044 / 2) shows that the voltage is proportional to the frequency in the linear region.</p>	
Pr 00.045 {05.008} Rated Speed	Defines the full load rated speed of the motor
Pr 00.042 {05.011} Number Of Motor Poles	Defines the number of motor poles
<p>The motor rated speed and motor rated frequency are used to determine the full load slip of the motor which is used by the vector control algorithm. Incorrect setting of this parameter has the following effects:</p> <ul style="list-style-type: none"> • Reduced efficiency of motor operation • Reduction of maximum torque available from the motor • Reduced transient performance • Inaccurate control of absolute torque in torque control modes <p>The nameplate value is normally the value for a hot motor; however, some adjustment may be required when the drive is commissioned if the nameplate value is inaccurate. Either a fixed value can be entered in this parameter or an optimization system may be used to automatically adjust this parameter (see <i>Rated Speed Optimisation Select</i> (00.033), later in this table).</p> <p>When Pr 00.042 is set to 'Automatic', the number of motor poles is automatically calculated from the motor <i>Rated Frequency</i> (00.047), and the motor <i>Rated Speed</i> (00.045).</p> <p>Number of poles = $120 \times (\text{Motor Rated Frequency (00.047)} / \text{Motor Rated Speed (00.045)})$ rounded to the nearest even number.</p>	
Pr 00.043 {5.10} Rated Power Factor	Defines the angle between the motor voltage and current
<p>The power factor is the true power factor of the motor, i.e. the angle between the motor voltage and current. If the <i>Stator Inductance</i> (05.025) is set to zero then the power factor is used in conjunction with the motor <i>Rated Current</i> (00.046) and other motor parameters to calculate the rated active and magnetising currents of the motor, which are used in the vector control algorithm. If the stator inductance has a non-zero value this parameter is not used by the drive, but is continuously written with a calculated value of power factor. The stator inductance can be measured by the drive by performing a rotating autotune (see <i>Autotune</i> (Pr 00.040), later in this table).</p>	

Safety information	Product information	Mechanical installation	Electrical installation	Getting started	Basic parameters	Running the motor	Optimization	Drive communication	NV Media Card Operation	Onboard PLC	Advanced parameters	Diagnostics	UL information
--------------------	---------------------	-------------------------	-------------------------	-----------------	------------------	-------------------	---------------------	---------------------	-------------------------	-------------	---------------------	-------------	----------------

Pr 00.040 {05.012} Autotune

There are four autotune tests available in RFC-A mode, a stationary autotune, a rotating autotune, two mechanical load measurement tests. A stationary autotune will give moderate performance whereas a rotating autotune will give improved performance as it measures the actual values of the motor parameters required by the drive. A mechanical load measurement test should be performed separately to a stationary or rotating autotune.

NOTE

It is highly recommended that a rotating autotune is performed (Pr **00.040** set to 2).

- A stationary autotune can be used when the motor is loaded and it is not possible to remove the load from the motor shaft. The stationary autotune measures the *Stator Resistance* (05.017) and *Transient Inductance* (05.024) of the motor. These are used to calculate the current loop gains, and at the end of the test the values in Pr **00.038** and Pr **00.039** are updated. A stationary autotune does not measure the power factor of the motor so the value on the motor nameplate must be entered into Pr **00.043**. To perform a Stationary autotune, set Pr **00.040** to 1, and provide the drive with both an enable signal (terminal 31 on Unidrive M700 / M701 and terminal 11 & 13 on Unidrive M702) and a run signal (terminal 26 or 27 on Unidrive M700 / M701 and terminal 7 or 8 on Unidrive M702).
- A rotating autotune should only be used if the motor is unloaded. A rotating autotune first performs a stationary autotune, a rotating test is then performed which the motor is accelerated with currently selected ramps up to a frequency of *Rated Frequency* (00.047) x 2/3, and the frequency is maintained at the level for up to 40 s. During the rotating autotune the *Stator Inductance* (05.025), and the motor saturation breakpoints (Pr **05.029**, Pr **05.030**, Pr **06.062** and Pr **05.063**) are modified by the drive. The *Motor Rated Power Factor* (00.043) is also modified by the *Stator Inductance* (05.025). The No-Load motor core losses are measured and written to *No-Load Core Losses* (04.045). To perform a Rotating autotune, set Pr **00.040** to 2, and provide the drive with both an enable signal (terminal 31 on Unidrive M700 / M701 and terminal 11 & 13 on Unidrive M702) and a run signal (terminal 26 or 27 on Unidrive M700 / M701 and terminal 7 or 8 on Unidrive M702).
- Mechanical load measurement test using signal injection.

This test measures the mechanical characteristic of the motor and load by rotating the motor at the speed defined by the present speed reference and injecting a series of speed test signals. This test should only be used provided all the basic control parameters have been set-up correctly and the speed controller parameters should be set to conservative levels, such as the default values, so that the motor is stable when it runs. The test measures the motor and load inertia, which can be used in automatic set-up of the speed controller gains and in producing a torque feed-forward term. If *Mechanical Load Test Level* (05.021) is left at its default value of zero then the peak level of the injection signal will be 1 % of the maximum speed reference subject to a maximum of 500 rpm. If a different test level is required then *Mechanical Load Test Level* (05.021) should be set to a non-zero value to define the level as a percentage of the maximum speed reference, again subject to a maximum of 500 rpm. The user defined speed reference which defines the speed of the motor should be set to a level higher than the test level, but not high enough for flux weakening to become active. In some cases however, it is possible to perform the test at zero speed provided the motor is free to move, but it may be necessary to increase the test signal from the default value. The test will give the correct results when there is a static load applied to the motor and in the presence of mechanical damping. This test should be used if possible, however for sensorless mode, or if the speed controller cannot be set up for stable operation an alternative test is provided (*Autotune* (00.040) = 4) where a series of torque levels are applied to accelerate and decelerate the motor to measure the inertia.

1. A rotating test is performed in which the motor is accelerated with the currently selected ramps up to the currently selected speed reference, and this speed is maintained for the duration of the test. The *Motor And Load Inertia* (03.018) is set-up.

To perform this autotune test, set Pr **00.040** to 3 and provide the drive with both an enable signal (on terminal 31 on Unidrive M700 / M701 and terminal 11 & 13 on Unidrive M702) and a run signal (terminal 26 or 27 on Unidrive M700 / M701 and terminal 7 or 8 on Unidrive M702).

- *Mechanical load measurement test using applied torque.*

Auto-tune test 3 should normally be used for mechanical load measurement, but under some circumstances this test may be used as an alternative. This test will not give such accurate results as test 3 if the motor rated speed is not set to the correct value for the motor. Also this test is likely to give incorrect results if standard ramp mode is active. A series of progressively larger torque levels are applied to the motor (20 %, 40 % ... 100 % of rated torque) to accelerate the motor up to 3/4 x *Rated Speed* (00.045) to determine the inertia from the acceleration/deceleration time. The test attempts to reach the required speed within 5 s, but if this fails the next torque level is used. When 100 % torque is used the test allows 60 s for the required speed to be reached, but if this is unsuccessful, an *Autotune 1* trip is initiated. To reduce the time taken for the test it is possible to define the level of torque to be used for the test by setting *Mechanical Load Test Level* (05.021) to a non-zero value. When the test level is defined the test is only carried out at the defined test level and 60 s is allowed for the motor to reach the required speed. It should be noted that if the maximum speed allows for flux weakening then it may not be possible to achieve the required torque level to accelerate the motor fast enough. If this is the case, the maximum speed reference should be reduced.

1. The motor is accelerated in the required direction up to 3/4 of the maximum speed reference and then decelerated to zero speed.
2. The test is repeated with progressively higher torques until the required speed is reached.
3. *Motor And Load Inertia* (03.018) and *Inertia Times 1000* (04.033) are set up.

To perform this autotune test, set Pr **00.040** to 4 and provide the drive with both an enable signal (on terminal 31 on Unidrive M700 / M701 and terminal 11 & 13 on Unidrive M702) and a run signal (terminal 26 or 27 on Unidrive M700 / M701 and terminal 7 or 8 on Unidrive M702).

Following the completion of an autotune test the drive will go into the inhibit state. The drive must be placed into a controlled disable condition before the drive can be made to run at the required reference. The drive can be put in to a controlled disable condition by removing the Safe Torque Off signal from terminal 31 on Unidrive M700 / M701 and terminal 11 & 13 on Unidrive M702, setting the *Drive Enable* (06.015) to Off (0) or disabling the drive via the control word (Pr **06.042** & Pr **06.043**).

Safety information	Product information	Mechanical installation	Electrical installation	Getting started	Basic parameters	Running the motor	Optimization	Drive communication	NV Media Card Operation	Onboard PLC	Advanced parameters	Diagnostics	UL information
--------------------	---------------------	-------------------------	-------------------------	-----------------	------------------	-------------------	---------------------	---------------------	-------------------------	-------------	---------------------	-------------	----------------

Pr 00.033 {05.016} *Rated Speed Optimisation Select*

The *Rated Frequency* (00.047) and *Rated Speed* (00.045) are used to define the rated slip of the motor. The rated slip is used in sensorless mode (*Sensorless Mode Active* (03.078) = 1) to correct the motor speed with load. When this mode is active *Rated Speed Optimisation Select* (00.033) has no effect.

If sensorless mode is not active (*Sensorless Mode Active* (03.078) = 0) the rated slip is used in the motor control algorithm and an incorrect value of slip can have a significant effect on the motor performance. If *Rated Speed Optimisation Select* (00.033) = 0 then the adaptive control system is disabled. However, if *Rated Speed Optimisation Select* (00.033) is set to a non-zero value the drive can automatically adjust the *Rated Speed* (00.045) to give the correct value of rated slip. *Rated Speed* (00.045) is not saved at power-down, and so when the drive is powered-down and up again it will return to the last value saved by the user. The rate of convergence and the accuracy of the adaptive controller reduces at low output frequency and low load. The minimum frequency is defined as a percentage of *Rated Frequency* (00.047) by *Rated Speed Optimisation Minimum Frequency* (05.019). The minimum load is defined as a percentage of rated load by *Rated Speed Optimisation Minimum Load* (05.020). The adaptive controller is enabled when a motoring or regenerative load rises above *Rated Speed Optimisation Minimum Load* (05.020) + 5%, and is disabled again when it falls below *Rated Speed Optimisation Minimum Load* (05.020). For best optimisation results the correct values of *Stator Resistance* (05.017), *Transient Inductance* (05.024), *Stator Inductance* (05.025), *Saturation Breakpoint 1* (05.029), *Saturation Breakpoint 2* (05.062), *Saturation Breakpoint 3* (05.030) and *Saturation Breakpoint 4* (05.063) should be used.

Pr 00.038 {04.013} / Pr 00.039 {04.014} *Current Loop Gains*

The current loop gains proportional (Kp) and integral (Ki) gains control the response of the current loop to a change in current (torque) demand. The default values give satisfactory operation with most motors. However, for optimal performance in dynamic applications it may be necessary to change the gains to improve the performance. The *Current Controller Kp Gain* (00.038) is the most critical value in controlling the performance. The values for the current loop gains can be calculated by performing a stationary or rotating autotune (see *Autotune* Pr 00.040, earlier in this table) the drive measures the *Stator Resistance* (05.017) and *Transient Inductance* (05.024) of the motor and calculates the current loop gains.

This will give a step response with minimum overshoot after a step change of current reference. The proportional gain can be increased by a factor of 1.5 giving a similar increase in bandwidth; however, this gives a step response with approximately 12.5 % overshoot. The equation for the integral gain gives a conservative value. In some applications where it is necessary for the reference frame used by the drive to dynamically follow the flux very closely (i.e. high speed Sensorless RFC-A induction motor applications) the integral gain may need to have a significantly higher value.

Speed Loop Gains (Pr 00.007 {03.010}, Pr 00.008 {03.011}, Pr 00.009 {03.012})

The speed loop gains control the response of the speed controller to a change in speed demand. The speed controller includes proportional (Kp) and integral (Ki) feed forward terms, and a differential (Kd) feedback term. The drive holds two sets of these gains and either set may be selected for use by the speed controller with Pr 03.016. If Pr 03.016 = 0, gains Kp1, Ki1 and Kd1 (Pr 00.007 to Pr 00.009) are used, and if Pr 03.016 = 1, gains Kp2, Ki2 and Kd2 (Pr 03.013 to Pr 03.015) are used. Pr 03.016 may be changed when the drive is enabled or disabled. If the load is predominantly a constant inertia and constant torque, the drive can calculate the required Kp and Ki gains to give a required compliance angle or bandwidth dependant on the setting of Pr 03.017.

Speed Controller Proportional Gain (Kp), Pr 00.007 {03.010} and Pr 03.013

If the proportional gain has a value and the integral gain is set to zero the controller will only have a proportional term, and there must be a speed error to produce a torque reference. Therefore as the motor load increases there will be a difference between the reference and actual speeds. This effect, called regulation, depends on the level of the proportional gain, the higher the gain the smaller the speed error for a given load. If the proportional gain is too high either the acoustic noise produced by speed feedback quantization becomes unacceptable, or the stability limit is reached.

Speed Controller Integral Gain (Ki), Pr 00.008 {03.011} and Pr 03.014

The integral gain is provided to prevent speed regulation. The error is accumulated over a period of time and used to produce the necessary torque demand without any speed error. Increasing the integral gain reduces the time taken for the speed to reach the correct level and increases the stiffness of the system, i.e. it reduces the positional displacement produced by applying a load torque to the motor. Unfortunately increasing the integral gain also reduces the system damping giving overshoot after a transient. For a given integral gain the damping can be improved by increasing the proportional gain. A compromise must be reached where the system response, stiffness and damping are all adequate for the application. For RFC-A Sensorless mode, it is unlikely that the integral gain can be increased much above 0.50.

Differential Gain (Kd), Pr 00.009 {0 3.012} and Pr 03.015

The differential gain is provided in the feedback of the speed controller to give additional damping. The differential term is implemented in a way that does not introduce excessive noise normally associated with this type of function. Increasing the differential term reduces the overshoot produced by under-damping, however, for most applications the proportional and integral gains alone are sufficient.

There are six methods of tuning the speed loop gains dependant on the setting of Pr 03.017:

1. Pr 03.017 = 0, User set-up.
This involves the connecting of an oscilloscope to analog output 1 to monitor the speed feedback.

Give the drive a step change in speed reference and monitor the response of the drive on the oscilloscope.

The proportional gain (Kp) should be set up initially. The value should be increased up to the point where the speed overshoots and then reduced slightly.

The integral gain (Ki) should then be increased up to the point where the speed becomes unstable and then reduced slightly.

It may now be possible to increase the proportional gain to a higher value and the process should be repeated until the system response matches the ideal response as shown.

The diagram shows the effect of incorrect P and I gain settings as well as the ideal response.

2. Pr 03.017 = 1, Bandwidth set-up
If bandwidth based set-up is required, the drive can calculate Kp and Ki if the following parameters are set up correctly:

- Pr 03.020 - Required bandwidth,
- Pr 03.021 - Required damping factor,
- Pr 03.018 - Motor and load inertia.

The drive can be made to measure the motor and load inertia by performing a mechanical load measurement autotune (see Autotune Pr 00.040, earlier in this table).

3. Pr 03.017 = 2, Compliance angle set-up
If compliance angle based set-up is required, the drive can calculate Kp and Ki if the following parameters are set up correctly:

- Pr 03.019 - Required compliance angle,
 - Pr 03.021 - Required damping factor,
 - Pr 03.018 - Motor and load inertia
- The drive can be made to measure the motor and load inertia by performing a mechanical load measurement autotune (see Autotune Pr 00.040, earlier in this table).

4. Pr 03.017 = 3, Kp gains times 16
If Speed Controller Set-up Method (03.017) = 3 the selected proportional gain used by the drive is multiplied by 16.

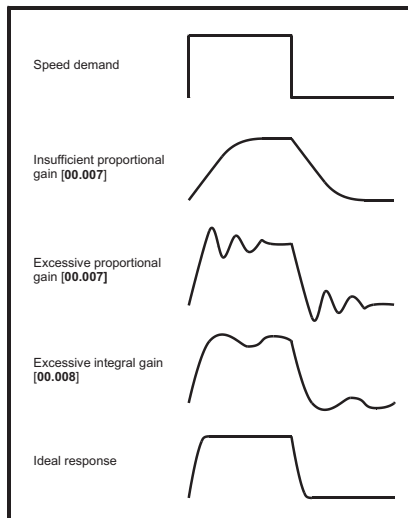

Pr 03.017 = 4 - 6

If Speed Controller Set-up Method (03.017) is set to a value from 4 to 6 the Speed Controller Proportional Gain Kp1 (03.010) and Speed Controller Integral Gain Ki1 (03.011) are automatically set up to give the bandwidths given in the table below and a damping factor of unity. These settings give low, standard or high performance.

Speed Controller Set-up Method (03.017)	Performance	Bandwidth
4	Low	5 Hz
5	Standard	25 Hz
6	High	100 Hz

6. Pr 03.017 = 7

If Speed Controller Set-up Method (03.017) = 7 then Speed Controller Proportional Gain Kp1 (03.010), Speed Controller Integral Gain Ki1 (03.011) and Speed Controller Differential Feedback Gain Kd1 (03.012) are set up to give a closed-loop speed controller response that approximates to a first order system with a transfer function of $1 / (s\tau + 1)$, where $\tau = 1/\omega_{bw}$ and $\omega_{bw} = 2\pi \times \text{Bandwidth}$ (03.020). In this case the damping factor is meaningless, and Damping Factor (03.021) and Compliance Angle (03.019) have no effect.

Safety information	Product information	Mechanical installation	Electrical installation	Getting started	Basic parameters	Running the motor	Optimization	Drive communication	NV Media Card Operation	Onboard PLC	Advanced parameters	Diagnostics	UL information
--------------------	---------------------	-------------------------	-------------------------	-----------------	------------------	-------------------	---------------------	---------------------	-------------------------	-------------	---------------------	-------------	----------------

8.1.3 RFC-A Sensorless mode

Induction motor without position feedback

Pr 00.046 {05.007} Motor Rated Current	Defines the maximum motor continuous current
<p>The motor rated current parameter must be set to the maximum continuous current of the motor. (See section 8.2 <i>Maximum motor rated current</i> on page 108, for information about setting this parameter higher than the maximum Heavy Duty current rating.) The motor rated current is used in the following:</p> <ul style="list-style-type: none"> • Current limits (see section 8.3 <i>Current limits</i> on page 108, for more information). • Motor thermal overload protection (see section 8.4 <i>Motor thermal protection</i> on page 108, for more information) • Vector control algorithm 	
Pr 00.044 {05.009} Rated Voltage	Defines the voltage applied to the motor at rated frequency
Pr 00.047 {05.006} Rated Frequency	Defines the frequency at which rated voltage is applied
<p>The <i>Rated Voltage</i> (00.044) and the <i>Rated Frequency</i> (00.047) are used to define the voltage to frequency characteristic applied to the motor (see <i>Open Loop Control Mode</i> (00.007), later in this table). The motor rated frequency is also used in conjunction with the motor rated speed to calculate the rated slip for slip compensation (see motor <i>Rated Speed</i> (00.045), later in this table).</p>	
<p>The graph, titled 'Output voltage characteristic', plots Output voltage on the vertical axis against Output frequency on the horizontal axis. A solid line starts at the origin and rises linearly until it reaches a point where the frequency is Pr 00.047 and the voltage is Pr 00.044. From this point, the line becomes horizontal, indicating constant output voltage. A dashed line from the point (Pr 00.047 / 2, Pr 00.044 / 2) shows that the voltage is proportional to the frequency in the linear region.</p>	
Pr 00.045 {05.008} Rated Speed	Defines the full load rated speed of the motor
Pr 00.042 {05.011} Number Of Motor Poles	Defines the number of motor poles
<p>The motor rated speed and motor rated frequency are used to determine the full load slip of the motor which is used by the vector control algorithm. Incorrect setting of this parameter has the following effects:</p> <ul style="list-style-type: none"> • Reduced efficiency of motor operation • Reduction of maximum torque available from the motor • Reduced transient performance • Inaccurate control of absolute torque in torque control modes <p>The nameplate value is normally the value for a hot motor; however, some adjustment may be required when the drive is commissioned if the nameplate value is inaccurate. Either a fixed value can be entered in this parameter or an optimization system may be used to automatically adjust this parameter (see <i>Rated Speed Optimization Select</i> (05.016), later in this table).</p> <p>When Pr 00.042 is set to 'Automatic', the number of motor poles is automatically calculated from the motor <i>Rated Frequency</i> (00.047), and the motor <i>Rated Speed</i> (00.045).</p> <p>Number of poles = $120 \times (\text{Motor Rated Frequency (00.047)} / \text{Motor Rated Speed (00.045)})$ rounded to the nearest even number.</p>	
Pr 00.043 {5.010} Rated Power Factor	Defines the angle between the motor voltage and current
<p>The power factor is the true power factor of the motor, i.e. the angle between the motor voltage and current. If the <i>Stator Inductance</i> (05.025) is set to zero then the power factor is used in conjunction with the motor <i>Rated Current</i> (00.046) and other motor parameters to calculate the rated active and magnetising currents of the motor, which are used in the vector control algorithm. If the stator inductance has a non-zero value this parameter is not used by the drive, but is continuously written with a calculated value of power factor. The stator inductance can be measured by the drive by performing a rotating autotune (see <i>Autotune</i> (Pr 00.040), later in this table).</p>	

Safety information	Product information	Mechanical installation	Electrical installation	Getting started	Basic parameters	Running the motor	Optimization	Drive communication	NV Media Card Operation	Onboard PLC	Advanced parameters	Diagnostics	UL information
--------------------	---------------------	-------------------------	-------------------------	-----------------	------------------	-------------------	---------------------	---------------------	-------------------------	-------------	---------------------	-------------	----------------

Pr 00.040 {05.012} Autotune

There are three autotune tests available in RFC-A mode, a stationary test, a rotating test and a mechanical load measurement test. A stationary autotune will give moderate performance whereas a rotating autotune will give improved performance as it measures the actual values of the motor parameters required by the drive. A mechanical load measurement test should be performed separately to a stationary or rotating autotune.

It is highly recommended that a rotating autotune is performed (Pr 00.040 set to 2).

- A stationary autotune can be used when the motor is loaded and it is not possible to remove the load from the motor shaft. The stationary autotune measures the *Stator Resistance* (05.017) and *Transient Inductance* (05.024) of the motor. These are used to calculate the current loop gains, and at the end of the test the values in Pr 00.038 and Pr 00.039 are updated. *Maximum Deadtime Compensation* (05.059) and *Current At Maximum Deadtime Compensation* (05.060) for the drive are also measured. Additionally, if *Enable Stator Compensation* (05.049) = 1, then *Stator Base Temperature* (05.048) is made equal to *Stator Temperature* (05.046). A stationary autotune does not measure the power factor of the motor so the value on the motor nameplate must be entered into Pr 00.043. To perform a stationary autotune, set Pr 00.040 to 1, and provide the drive with both an enable signal (terminal 31 on Unidrive M700 / M701 and terminal 11 & 13 on Unidrive M702) and a run signal (terminal 26 or 27 on Unidrive M700 / M701 and terminal 7 or 8 on Unidrive M702).
- A rotating autotune should only be used if the motor is unloaded. A rotating autotune first performs a stationary autotune, a rotating test is then performed in which the motor is accelerated with currently selected ramps up to a frequency of *Rated Frequency* (00.047) x 2/3, and the frequency is maintained at the level for up to 40 s. During the rotating autotune the *Stator Inductance* (05.025), and the motor saturation breakpoints (Pr 05.029, Pr 05.030, Pr 06.062 and Pr 05.063) are modified by the drive. The power factor is also modified for user information only, but is not used after this point as the stator inductance is used in the vector control algorithm instead. To perform a Rotating autotune, set Pr 00.040 to 2, and provide the drive with both an enable signal (terminal 31 on Unidrive M700 / M701 and terminal 11 & 13 on Unidrive M702) and a run signal (terminal 26 or 27 on Unidrive M700 / M701 and terminal 7 or 8 on Unidrive M702).
- The mechanical load measurement test can measure the total inertia of the load and the motor. This is used to set the speed loop gains (see Speed loop gains) and to provide torque feed-forwards when required during acceleration.

Applied torque (sensorless mode) This test may give inaccurate results, if the motor rated speed is not set to the correct value for the motor, or if standard ramp mode is active. During the mechanical load measurement test a series of progressively larger torque levels are applied to the motor (20 %, 40 % ... 100 % of rated torque) to accelerate the motor up to $\frac{3}{4} \times \text{Rated Speed}$ (00.045) to determine the inertia from the acceleration/deceleration time. The test attempts to reach the required speed within 5 s, but if this fails the next torque level is used. When 100 % torque is used the test allows 60 s for the required speed to be reached, but if this is unsuccessful an Autotune 1 trip is initiated. To reduce the time taken for the test it is possible to define the level of torque to be used for the test by setting *Mechanical Load Test Level* (05.021) to a non-zero value. When the test level is defined the test is only carried out at the defined test level and 60 s is allowed for the motor to reach the required speed. It should be noted that if the maximum speed allows for flux weakening then it may not be possible to achieve the required torque level to accelerate the motor quickly enough. If this is the case, the maximum speed reference should be reduced. To perform a mechanical load measurement autotune, set Pr 00.040 to 4, and provide the drive with both an enable signal (terminal 31 on Unidrive M700 / M701 and terminal 11 & 13 on Unidrive M702) and a run signal (terminal 26 or 27 on Unidrive M700 / M701 and terminal 7 or 8 on Unidrive M702).

Following the completion of an autotune test the drive will go into the inhibit state. The drive must be placed into a controlled disable condition before the drive can be made to run at the required reference. The drive can be put in to a controlled disable condition by removing the Safe Torque Off signal from terminal 31, setting the *Drive Enable* (06.015) to OFF (0) or disabling the drive via the control word (Pr 06.042 & Pr 06.043)

Pr 00.038 {04.013} / Pr 00.039 {04.014} Current Loop Gains

The current loop gains proportional (Kp) and integral (Ki) gains control the response of the current loop to a change in current (torque) demand. The default values give satisfactory operation with most motors. However, for optimal performance in dynamic applications it may be necessary to change the gains to improve the performance. The *Current Controller Kp Gain* (00.038) is the most critical value in controlling the performance. The values for the current loop gains can be calculated by performing a stationary or rotating autotune (see *Autotune* Pr 00.040, earlier in this table) the drive measures the *Stator Resistance* (05.017) and *Transient Inductance* (05.024) of the motor and calculates the current loop gains.

This will give a step response with minimum overshoot after a step change of current reference. The proportional gain can be increased by a factor of 1.5 giving a similar increase in bandwidth; however, this gives a step response with approximately 12.5 % overshoot. The equation for the integral gain gives a conservative value. In some applications where it is necessary for the reference frame used by the drive to dynamically follow the flux very closely (i.e. high speed Sensorless RFC-A induction motor applications) the integral gain may need to have a significantly higher value.

Speed Loop Gains (Pr 00.007 {03.010}, Pr 00.008 {03.011}, Pr 00.009 {03.012})

The speed loop gains control the response of the speed controller to a change in speed demand. The speed controller includes proportional (Kp) and integral (Ki) feed forward terms, and a differential (Kd) feedback term. The drive holds two sets of these gains and either set may be selected for use by the speed controller with Pr 03.016. If Pr 03.016 = 0, gains Kp1, Ki1 and Kd1 (Pr 00.007 to Pr 00.009) are used, and if Pr 03.016 = 1, gains Kp2, Ki2 and Kd2 (Pr 03.013 to Pr 03.015) are used. Pr 03.016 may be changed when the drive is enabled or disabled. If the load is predominantly a constant inertia and constant torque, the drive can calculate the required Kp and Ki gains to give a required compliance angle or bandwidth dependant on the setting of Pr 03.017.

Speed Controller Proportional Gain (Kp), Pr 00.007 {03.010} and Pr 03.013

If the proportional gain has a value and the integral gain is set to zero the controller will only have a proportional term, and there must be a speed error to produce a torque reference. Therefore as the motor load increases there will be a difference between the reference and actual speeds. This effect, called regulation, depends on the level of the proportional gain, the higher the gain the smaller the speed error for a given load. If the proportional gain is too high either the acoustic noise produced by speed feedback quantization becomes unacceptable, or the stability limit is reached.

Speed Controller Integral Gain (Ki), Pr 00.008 {03.011} and Pr 03.014

The integral gain is provided to prevent speed regulation. The error is accumulated over a period of time and used to produce the necessary torque demand without any speed error. Increasing the integral gain reduces the time taken for the speed to reach the correct level and increases the stiffness of the system, i.e. it reduces the positional displacement produced by applying a load torque to the motor. Unfortunately increasing the integral gain also reduces the system damping giving overshoot after a transient. For a given integral gain the damping can be improved by increasing the proportional gain. A compromise must be reached where the system response, stiffness and damping are all adequate for the application. For RFC-A Sensorless mode, it is unlikely that the integral gain can be increased much above 0.50.

Differential Gain (Kd), Pr 00.009 {0 3.012} and Pr 03.015

The differential gain is provided in the feedback of the speed controller to give additional damping. The differential term is implemented in a way that does not introduce excessive noise normally associated with this type of function. Increasing the differential term reduces the overshoot produced by under-damping, however, for most applications the proportional and integral gains alone are sufficient.

There are six methods of tuning the speed loop gains dependant on the setting of Pr 03.017:

1. Pr 03.017 = 0, User set-up.
This involves the connecting of an oscilloscope to analog output 1 to monitor the speed feedback.
Give the drive a step change in speed reference and monitor the response of the drive on the oscilloscope.
The proportional gain (Kp) should be set up initially. The value should be increased up to the point where the speed overshoots and then reduced slightly.
The integral gain (Ki) should then be increased up to the point where the speed becomes unstable and then reduced slightly.
It may now be possible to increase the proportional gain to a higher value and the process should be repeated until the system response matches the ideal response as shown.
The diagram shows the effect of incorrect P and I gain settings as well as the ideal response.
2. Pr 03.017 = 1, Bandwidth set-up
If bandwidth based set-up is required, the drive can calculate Kp and Ki if the following parameters are set up correctly:
Pr 03.020 - Required bandwidth,
Pr 03.021 - Required damping factor,
Pr 03.018 - Motor and load inertia.
The drive can be made to measure the motor and load inertia by performing a mechanical load measurement autotune (see Autotune Pr 00.040, earlier in this table).
3. Pr 03.017 = 2, Compliance angle set-up
If compliance angle based set-up is required, the drive can calculate Kp and Ki if the following parameters are set up correctly:
Pr 03.019 - Required compliance angle,
Pr 03.021 - Required damping factor,
Pr 03.018 - Motor and load inertia
The drive can be made to measure the motor and load inertia by performing a mechanical load measurement autotune (see Autotune Pr 00.040, earlier in this table).
4. Pr 03.017 = 3, Kp gains times 16
If Speed Controller Set-up Method (03.017) = 3 the selected proportional gain used by the drive is multiplied by 16.

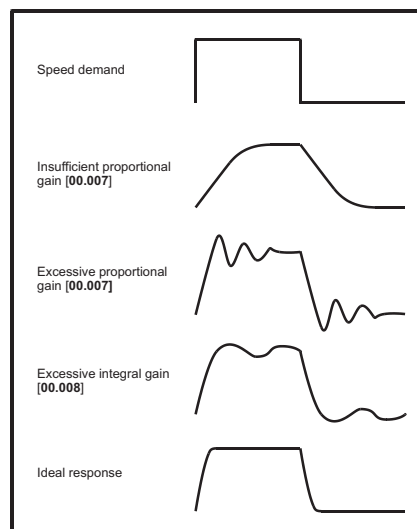

5. Pr 03.017 = 4 - 6
If Speed Controller Set-up Method (03.017) is set to a value from 4 to 6 the Speed Controller Proportional Gain Kp1 (03.010) and Speed Controller Integral Gain Ki1 (03.011) are automatically set up to give the bandwidths given in the table below and a damping factor of unity. These settings give low, standard or high performance.

Pr 03.017	Performance	Bandwidth
4	Low	5 Hz
5	Standard	25 Hz
6	High	100 Hz

6. Pr 03.017 = 7
If Speed Controller Set-up Method (03.017) = 7 then Speed Controller Proportional Gain Kp1 (03.010), Speed Controller Integral Gain Ki1 (03.011) and Speed Controller Differential Feedback Gain Kd1 (03.012) are set up to give a closed-loop speed controller response that approximates to a first order system with a transfer function of $1 / (s\tau + 1)$, where $\tau = 1/\omega_{bw}$ and $\omega_{bw} = 2\pi \times \text{Bandwidth}$ (03.020). In this case the damping factor is meaningless, and Damping Factor (03.021) and Compliance Angle (03.019) have no effect.

Safety information	Product information	Mechanical installation	Electrical installation	Getting started	Basic parameters	Running the motor	Optimization	Drive communication	NV Media Card Operation	Onboard PLC	Advanced parameters	Diagnostics	UL information
--------------------	---------------------	-------------------------	-------------------------	-----------------	------------------	-------------------	---------------------	---------------------	-------------------------	-------------	---------------------	-------------	----------------

8.1.4 RFC-S mode

Permanent magnet motor with Position feedback

Pr 00.046 {05.007} Rated Current

Defines the maximum motor continuous current

The motor rated current parameter must be set to the maximum continuous current of the motor. The motor rated current is used in the following:

- Current limits (see section 8.3 *Current limits* on page 108, for more information)
- Motor thermal overload protection (see section 8.4 *Motor thermal protection* on page 108, for more information)

Pr 00.042 {05.011} Number Of Motor Poles

Defines the number of motor poles

The number of motor poles parameter defines the number of electrical revolutions in one whole mechanical revolution of the motor. This parameter must be set correctly for the control algorithms to operate correctly. When Pr **00.042** is set to "Automatic" the number of poles is 6.

Pr 00.040 {05.012} Autotune

There are four autotune tests available in RFC-S mode, a stationary autotune, a rotating autotune, mechanical load measurement tests to measure load dependent parameters.

• Stationary Autotune

The stationary autotune can be used when the motor is loaded and it is not possible uncouple the load from motor shaft. This test can be used to measure all the necessary parameters for basic control. During the stationary autotune, a test is performed to locate the flux axis of the motor. However this test may not be able to calculate such an accurate value for the *Position Feedback Phase Angle* (00.043) as compared to rotating autotune. A stationary test is performed to measure *Stator Resistance* (05.017), *Ld* (05.024), *Maximum Deadtime Compensation* (05.059), *Current At Maximum Deadtime Compensation* (05.060), *No Load Lq* (05.072). If *Enable Stator Compensation* (05.049) = 1 then *Stator Base Temperature* (05.048) is made equal to *Stator Temperature* (05.046). The *Stator Resistance* (05.017) and the *Ld* (05.024) are then used to set up *Current controller Kp Gain* (00.038) and *Current Controller Ki Gain* (00.039). If sensorless mode is not selected then *Position Feedback Phase Angle* (00.043) is set up for the position from the position feedback interface selected with *Motor Control Feedback Select* (03.026). To perform a Stationary autotune, set Pr **00.040** to 1, and provide the drive with both an enable signal (terminal 31 on Unidrive M700 / M701 and terminal 11 & 13 on Unidrive M702) and a run signal (terminal 26 or 27 on Unidrive M700 / M701 and terminal 7 or 8 on Unidrive M702).

• Rotating Autotune

The rotating autotune must be performed on unloaded motor. This test can be used to measure all the necessary parameters for the basic control and parameters for cancelling the effects of the cogging torque.

During the rotating autotune, *Rated Current* (00.046) is applied and the motor is rotated by 2 electrical revolutions (i.e. up to 2 mechanical revolutions) in the required direction. If sensorless mode is not selected then the *Position Feedback Phase Angle* (00.043) is set-up for the position from the position feedback interface selected with *Motor Control Feedback Select* (03.026). A stationary test is then performed to measure *Stator Resistance* (05.017), *Ld* (05.024), *Maximum Deadtime Compensation* (05.059), *Current At Maximum Deadtime Compensation* (05.060) and *No Load Lq* (05.072). *Stator Resistance* (05.017) and *Ld* (05.024) are used to set up *Current Controller Kp Gain* (00.038) and *Current Controller Ki Gain* (00.039). This is only done once during the test, and so the user can make further adjustments to the current controller gains if required. To perform a Rotating autotune, set Pr **00.040** to 2, and provide the drive with both an enable signal (terminal 31 on Unidrive M700 / M701 and terminal 11 & 13 on Unidrive M702) and a run signal (terminal 26 or 27 on Unidrive M700 / M701 and terminal 7 or 8 on Unidrive M702).

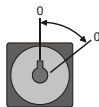

• Mechanical load measurement test using signal injection

The mechanical load measurement test using signal injection, measures the mechanical characteristic of the motor and load by rotating the motor at the speed defined by the present speed reference and injecting a series of speed test signals. This test should only be used provided all the basic control parameters (including *Torque Per Amp* (05.032)) have been set-up correctly and the speed controller parameters should be set to conservative levels, such as the default values, so that the motor is stable when it runs. The test measures the motor and load inertia, which can be used in automatic set-up of the speed controller gains and in producing a torque feed-forward term. If *Mechanical Load Test Level* (05.021) is left at its default value of zero then the peak level of the injection signal will be 1 % of the maximum speed reference subject to a maximum of 500 rpm. If a different test level is required then *Mechanical Load Test Level* (05.021) should be set to a non-zero value to define the level as a percentage of the maximum speed reference, again subject to a maximum of 500 rpm. The user defined speed reference which defines the speed of the motor should be set to a level higher than the test level, but not high enough for flux weakening to become active. In some cases, however it is possible to perform the test at zero speed provided the motor is free to move, but it may be necessary to increase the test signal from the default value. The test will give the correct results when there is a static load applied to the motor and in the presence of mechanical damping. This test should be used if possible, however for sensorless mode, or if the speed controller cannot be set up for stable operation an alternative test is provided (*Autotune* (00.040) = 4) where a series of torque levels are applied to accelerate and decelerate the motor to measure the inertia.

1. A rotating test is performed in which the motor is accelerated with the currently selected ramps up to the currently selected speed reference, and this speed is maintained for the duration of the test. *Motor And Load Inertia* (03.018) and *Inertia Times 1000* (04.033) are set up.

To perform this autotune test, set Pr **00.040** to 3 and provide the drive with both an enable signal (on terminal 31 on Unidrive M700 / M701 and terminal 11 & 13 on Unidrive M702) and a run signal (terminal 26 or 27 on Unidrive M700 / M701 and terminal 7 or 8 on Unidrive M702).

• Mechanical load measurement using applied torque

Auto-tune test 3 should normally be used for mechanical load measurement, but under some circumstances this test may be used as an alternative. This test is likely to give incorrect results if standard ramp mode is active. A series of progressively larger torque levels are applied to the motor (20 %, 40 % ... 100 % of rated torque) to accelerate the motor up to $\frac{3}{4} \times \text{Rated Speed}$ (00.045) to determine the inertia from the acceleration/deceleration time. The test attempts to reach the required speed within 5s, but if this fails the next torque level is used. When 100 % torque is used the test allows 60 s for the required speed to be reached, but if this is unsuccessful, a trip is initiated. To reduce the time taken for the test it is possible to define the level of torque to be used for the test by setting *Mechanical Load Test Level* (05.021) to a non-zero value. When the test level is defined the test is only carried out at the defined test level and 60 s is allowed for the motor to reach the required speed. It should be noted that if the maximum speed allows for flux weakening then it may not be possible to achieve the required torque level to accelerate the motor fast enough. If this is the case, the maximum speed reference should be reduced.

1. The motor is accelerated in the required direction up to $\frac{3}{4}$ of the maximum speed reference and then decelerated to zero speed.
2. The test is repeated with progressively higher torques until the required speed is reached.
3. *Motor And Load Inertia* (03.018) and *Inertia Times 1000* (04.033) are set up. To perform this autotune test, set Pr 00.040 to 4 and provide the drive with both an enable signal (on terminal 31 on Unidrive M700/M701 and terminal 11 & 13 on Unidrive M702) and a run signal (terminal 26 or 27 on Unidrive M700/M701 and terminal 7 or 8 on Unidrive M702).

Safety information	Product information	Mechanical installation	Electrical installation	Getting started	Basic parameters	Running the motor	Optimization	Drive communication	NV Media Card Operation	Onboard PLC	Advanced parameters	Diagnostics	UL information
--------------------	---------------------	-------------------------	-------------------------	-----------------	------------------	-------------------	--------------	---------------------	-------------------------	-------------	---------------------	-------------	----------------

Pr 00.038 {04.013} / Pr 00.039 {04.014} *Current Loop Gains*

The current loop gains proportional (Kp) and integral (Ki) gains control the response of the current loop to a change in current (torque) demand. The default values give satisfactory operation with most motors. However, for optimal performance in dynamic applications it may be necessary to change the gains to improve the performance. The proportional gain (Pr 00.038) is the most critical value in controlling the performance. The values for the current loop gains can be calculated by performing a stationary or rotating autotune (see *Autotune* Pr 00.040, earlier in this table) the drive measures the *Stator Resistance* (05.017) and *Transient Inductance* (05.024) of the motor and calculates the current loop gains.

This will give a step response with minimum overshoot after a step change of current reference. The proportional gain can be increased by a factor of 1.5 giving a similar increase in bandwidth; however, this gives a step response with approximately 12.5 % overshoot. The equation for the integral gain gives a conservative value. In some applications where it is necessary for the reference frame used by the drive to dynamically follow the flux very closely (i.e. high speed Sensorless RFC-A induction motor applications) the integral gain may need to have a significantly higher value.

Speed loop gains (Pr 00.007 {03.010}, Pr 00.008 {03.011}, Pr 00.009 {03.012})

The speed loop gains control the response of the speed controller to a change in speed demand. The speed controller includes proportional (Kp) and integral (Ki) feed forward terms, and a differential (Kd) feedback term. The drive holds two sets of these gains and either set may be selected for use by the speed controller with Pr **03.016**. If Pr **03.016** = 0, gains Kp1, Ki1 and Kd1 (Pr **00.007** to Pr **00.009**) are used, and if Pr **03.016** = 1, gains Kp2, Ki2 and Kd2 (Pr **03.013** to Pr **03.015**) are used. Pr **03.016** may be changed when the drive is enabled or disabled. If the load is predominantly a constant inertia and constant torque, the drive can calculate the required Kp and Ki gains to give a required compliance angle or bandwidth dependant on the setting of Pr **03.017**.

Speed Controller Proportional Gain (Kp), Pr **00.007** {03.010} and Pr **03.013**

If the proportional gain has a value and the integral gain is set to zero the controller will only have a proportional term, and there must be a speed error to produce a torque reference. Therefore as the motor load increases there will be a difference between the reference and actual speeds. This effect, called regulation, depends on the level of the proportional gain, the higher the gain the smaller the speed error for a given load. If the proportional gain is too high either the acoustic noise produced by speed feedback quantization becomes unacceptable, or the stability limit is reached.

Speed Controller Integral Gain (Ki), Pr **00.008** {03.011} and Pr **03.014**

The integral gain is provided to prevent speed regulation. The error is accumulated over a period of time and used to produce the necessary torque demand without any speed error. Increasing the integral gain reduces the time taken for the speed to reach the correct level and increases the stiffness of the system, i.e. it reduces the positional displacement produced by applying a load torque to the motor. Unfortunately increasing the integral gain also reduces the system damping giving overshoot after a transient. For a given integral gain the damping can be improved by increasing the proportional gain. A compromise must be reached where the system response, stiffness and damping are all adequate for the application.

Differential Gain (Kd), Pr **00.009** {03.012} and Pr **03.015**

The differential gain is provided in the feedback of the speed controller to give additional damping. The differential term is implemented in a way that does not introduce excessive noise normally associated with this type of function. Increasing the differential term reduces the overshoot produced by under-damping, however, for most applications the proportional and integral gains alone are sufficient.

Speed loop gains (cont) (Pr 00.007 {03.010}, Pr 00.008 {03.011}, Pr 00.009 {03.012})

There are three methods of tuning the speed loop gains dependant on the setting of Pr 03.017:

- Pr 03.017 = 0, User set-up.
This involves the connecting of an oscilloscope to analog output 1 to monitor the speed feedback.
Give the drive a step change in speed reference and monitor the response of the drive on the oscilloscope.
The proportional gain (Kp) should be set up initially. The value should be increased up to the point where the speed overshoots and then reduced slightly.
The integral gain (Ki) should then be increased up to the point where the speed becomes unstable and then reduced slightly.
It may now be possible to increase the proportional gain to a higher value and the process should be repeated until the system response matches the ideal response as shown.
The diagram shows the effect of incorrect P and I gain settings as well as the ideal response.
- Pr 03.017 = 1, Bandwidth set-up
If bandwidth based set-up is required, the drive can calculate Kp and Ki if the following parameters are set up correctly:
Pr 03.020 - Required bandwidth,
Pr 03.021 - Required damping factor,
Pr 03.018 - Motor and load inertia.
The drive can be made to measure the motor and load inertia by performing a mechanical load measurement autotune (see *Autotune* Pr 00.040, earlier in this table).
- Pr 03.017 = 2, Compliance angle set-up
If compliance angle based set-up is required, the drive can calculate Kp and Ki if the following parameters are set up correctly:
Pr 03.019 - Required compliance angle,
Pr 03.021 - Required damping factor,
Pr 03.018 - Motor and load inertia
The drive can be made to measure the motor and load inertia by performing a mechanical load autotune (see *Autotune* Pr 00.040, earlier in this table).
- Pr 03.017 = 3, Kp gains times 16
If *Speed Controller Set-up Method* (03.017) = 3 the selected proportional gain used by the drive is multiplied by 16.

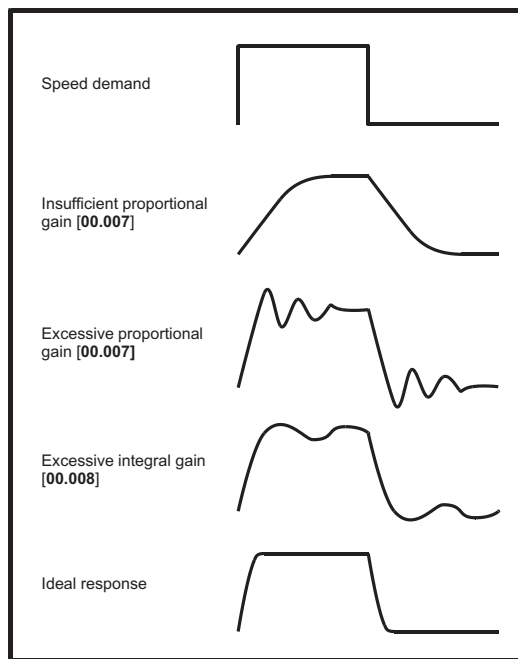

- Pr 03.017 = 4 - 6
If *Speed Controller Set-up Method* (03.017) is set to a value from 4 to 6 the *Speed Controller Proportional Gain Kp1* (03.010) and *Speed Controller Integral Gain Ki1* (03.011) are automatically set up to give the bandwidths given in the table below and a damping factor of unity. These settings give low, standard or high performance.

Speed Controller Set-up Method (03.017)	Performance	Bandwidth
4	Low	5 Hz
5	Standard	25 Hz
6	High	100 Hz

- Pr 03.017 = 7
If *Speed Controller Set-up Method* (03.017) = 7 then *Speed Controller Proportional Gain Kp1* (03.010), *Speed Controller Integral Gain Ki1* (03.011) and *Speed Controller Differential Feedback Gain Kd1* (03.012) are set up to give a closed-loop speed controller response that approximates to a first order system with a transfer function of $1 / (s\tau + 1)$, where $\tau = 1/\omega_{bw}$ and $\omega_{bw} = 2\pi \times \text{Bandwidth}$ (03.020). In this case the damping factor is meaningless, and *Damping Factor* (03.021) and *Compliance Angle* (03.019) have no effect.

Safety information	Product information	Mechanical installation	Electrical installation	Getting started	Basic parameters	Running the motor	Optimization	Drive communication	NV Media Card Operation	Onboard PLC	Advanced parameters	Diagnostics	UL information
--------------------	---------------------	-------------------------	-------------------------	-----------------	------------------	-------------------	---------------------	---------------------	-------------------------	-------------	---------------------	-------------	----------------

8.2 Maximum motor rated current

The maximum motor rated current allowed by the drive is greater than the *Maximum Heavy Duty Current Rating* (00.032). The ratio between the Normal Duty rating and the *Maximum Heavy Duty Current Rating* (00.032) varies between drive sizes. The values for the Normal and Heavy Duty rating can be found in the *Power Installation Guide*. If the motor *Rated Current* (00.046) is set above the *Maximum Heavy Duty Current Rating* (00.032), the current limits and the motor thermal protection scheme are modified (see section 8.3 *Current limits* on page 108 and section 8.4 *Motor thermal protection* on page 108 for more information).

8.3 Current limits

The default setting for the current limit parameters is:

- 165 % (141.9 % for frame 9 and above) x motor rated torque producing current for open loop mode
- 175 % (150 % for frame 9 and above) x motor rated torque producing current for RFC-A and RFC-S modes

There are three parameters which control the current limits:

- Motoring current limit: power flowing from the drive to the motor
- Regen current limit: power flowing from the motor to the drive
- Symmetrical current limit: current limit for both motoring and regen operation

The lowest of either the motoring and regen current limit, or the symmetrical current limit applies.

The maximum setting of these parameters depends on the values of motor rated current, drive rated current and the power factor.

Increasing the motor rated current (Pr **00.046/05.007**) above the Heavy Duty rating (default value), will automatically reduce the current limits in Pr **04.005** to Pr **04.007**. If the motor rated current is then set to or below the Heavy Duty rating, the current limits will be left at their reduced values.

The drive can be oversized to permit a higher current limit setting to provide higher accelerating torque as required up to a maximum of 1000 %.

8.4 Motor thermal protection

A dual time constant thermal model is provided to estimate the motor temperature as a percentage of its maximum allowed temperature.

The motor thermal protection is modelled using losses in the motor. The losses in the motor are calculated as a percentage value, so that under these conditions the *Motor Protection Accumulator* (04.019) would eventually reach 100 %.

$$\text{Percentage losses} = 100 \% \times [\text{Load related losses} + \text{Iron losses}]$$

Where:

$$\text{Load related losses} = (1 - K_{fe}) \times [(I / (K_1 \times I_{Rated}))^2]$$

$$\text{Iron losses} = K_{fe} \times (w / w_{Rated})^{1.6}$$

Where:

$$I = \text{Current Magnitude (00.012)}$$

$$I_{Rated} = \text{Rated Current (00.046)}$$

$$K_{fe} = \text{Rated Iron Losses As Percentage Of Losses (04.039)} / 100 \%$$

The *Motor Protection Accumulator* (04.019) is given by:

$$\text{Pr } 04.019 = \text{Percentage Losses} \times [(1 - K_2) (1 - e^{-t/\tau_1}) + K_2 (1 - e^{-t/\tau_2})]$$

Where:

$$T = \text{Motor Protection Accumulator (04.019)}$$

$$K_2 = \text{Motor Thermal Time Constant 2 Scaling (04.038)} / 100 \%$$

$$\tau_1 = \text{Motor Thermal Time Constant 1 (00.053)}$$

$$\tau_2 = \text{Motor Thermal Time Constant 2 (04.037)}$$

$$K_1 = \text{Varies, see below}$$

If *Rated Current* (00.046) ≤ *Maximum Heavy Duty Current* (00.032)

Figure 8-1 Motor thermal protection (Heavy Duty)

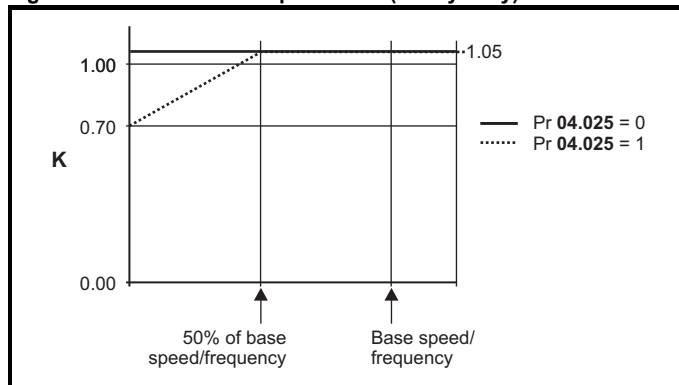

If Pr **04.025** is 0 the characteristic is for a motor which can operate at rated current over the whole speed range. Induction motors with this type of characteristic normally have forced cooling. If Pr **04.025** is 1 the characteristic is intended for motors where the cooling effect of motor fan reduces with reduced motor speed below 50 % of base speed/frequency. The maximum value for K1 is 1.05, so that above the knee of the characteristics the motor can operate continuously up to 105 % current.

Figure 8-2 Motor thermal protection (Normal Duty)

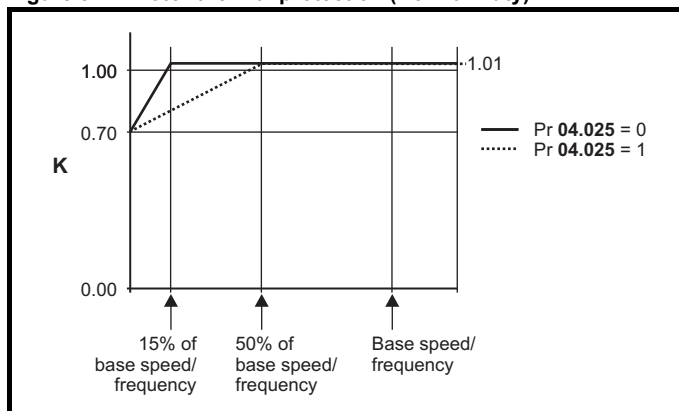

Both settings of Pr **04.025** are intended for motors where the cooling effect of the motor fan reduces with reduced motor speed, but with different speeds below which the cooling effect is reduced. If Pr **04.025** is 0 the characteristic is intended for motors where the cooling effect reduces with motor speed below 15 % of base speed/frequency. If Pr **04.025** is 1 the characteristic is intended for motors where the cooling effect reduces with motor speed below 50 % of base speed/frequency. The maximum value for K1 is 1.01, so that above the knee of the characteristics the motor can operate continuously up to 101 % current.

When the estimated temperature in Pr **04.019** reaches 100 % the drive takes some action depending on the setting of Pr **04.016**. If Pr **04.016** is 0, the drive trips when Pr **04.019** reaches 100 %. If Pr **04.016** is 1, the current limit is reduced to (K - 0.05) x 100 % when Pr **04.019** reaches 100 %.

The current limit is set back to the user defined level when Pr **04.019** falls below 95 %. The thermal model temperature accumulator accumulates the temperature of the motor while the drive remains powered-up. By default, the accumulator is set to the power down value at power-up. If the rated current defined by Pr **00.046** is altered, the accumulator is reset to zero.

The default setting of the thermal time constant (Pr **00.053**) is 89 s which is equivalent to an overload of 150 % for 60 s from cold.

8.5 Switching frequency

The default switching frequency is 3 kHz (6 kHz in RFC-S mode), however this can be increased up to a maximum of 16 kHz by Pr **00.041** (dependent on drive size). The available switching frequencies are shown below.

Table 8-1 Available switching frequencies

Drive size	Model	2 kHz	3 kHz	4 kHz	6 kHz	8 kHz	12 kHz	16 kHz
3	All							
4								
5								
6		✓	✓	✓	✓	✓	✓	✓
7								
8								
9E								
10	10202830 to 10203000							
	10501520 to 10501900	✓	✓	✓	✓	✓	✓	✓
	10601500 to 10601780							
	10402700 to 10403200	✓	✓	✓	✓			
11	400 V	✓	✓	✓	✓	✓		
11	575 and 690 V	✓	✓	✓				

If switching frequency is increased from 3 kHz the following apply:

- Increased heat loss in the drive, which means that derating to the output current must be applied. See the derating tables for switching frequency and ambient temperature in the *Power Installation Guide*.
- Reduced heating of the motor - due to improved output waveform quality.
- Reduced acoustic noise generated by the motor.
- Increased sample rate on the speed and current controllers. A trade off must be made between motor heating, drive heating and the demands of the application with respect to the sample time required.

Table 8-1 Sample rates for various control tasks at each switching frequency

Level	3, 6, 12 kHz	2, 4, 8, 16 kHz	Open loop	RFC-A RFC-S
Level 1	3 kHz - 167µs 6 kHz - 83 µs 12 kHz - 83 µs	2 kHz - 250 µs 4 kHz - 125 µs 8 kHz - 62.5 µs 16 kHz - 62.5 µs	Peak limit	Current controllers
Level 2	250 µs	2 kHz - 500 µs 4 kHz - 250 µs 8 kHz - 250 µs 16 kHz - 250 µs	Current limit and ramps	Speed controller and ramps
Level 3	1 ms		Voltage controller	
Level 4	4 ms		Time critical user interface	
Background			Non-time critical user interface	

8.6 High speed operation

8.6.1 Encoder feedback limits

The maximum encoder frequency should be prevented from exceeding 500 kHz. In RFC-A and RFC-S modes the maximum speed that can be entered in to the speed reference clamps (Pr **00.002** and Pr **00.001**) can be limited by the drive. This is defined by the following (subject to an absolute maximum of 33,000 rpm):

$$\begin{aligned} \text{Maximum speed limit (rpm)} &= \frac{500 \text{ kHz} \times 60}{\text{ELPR}} \\ &= \frac{3.0 \times 10^7}{\text{ELPR}} \end{aligned}$$

Where:

ELPR is the equivalent encoder lines per revolution and is the number of lines that would be produced by a quadrature encoder.

- Quadrature encoder ELPR = number of lines per revolution
- F and D encoder ELPR = number of lines per revolution / 2
- SINCOS encoder ELPR = number of sine waves per revolution

This maximum speed limit is defined by the device selected with the speed feedback selector (Pr **03.026**), and the ELPR set for the position feedback device. In RFC-A mode it is possible to disable this limit via Pr **03.024**, so that the drive can be switched between operation with and without feedback when the speed becomes too high for the feedback device.

8.6.2 Field weakening (constant power) operation

(Open loop and RFC-A mode only)

The drive can be used to run an induction machine above synchronous speed into the constant power region. The speed continues to increase and the available shaft torque reduces. The characteristics below show the torque and output voltage characteristics as the speed is increased above the rated value.

Figure 8-3 Torque and rated voltage against speed

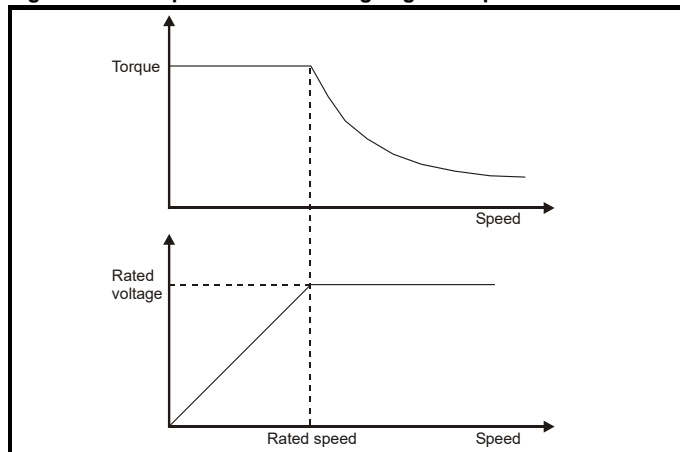

Care must be taken to ensure the torque available above base speed is sufficient for the application to run satisfactorily. The saturation breakpoint parameters (Pr **05.029**, Pr **05.030**, Pr **05.062** and Pr **05.063**) found during the autotune in RFC-A mode ensure the magnetizing current is reduced in the correct proportion for the specific motor. (In open loop mode the magnetizing current is not actively controlled).

8.6.3 Permanent magnet motor high speed operation

High speed servo mode is enabled by setting Pr **05.022** = 1. Care must be taken when using this mode with permanent magnet motor to avoid damaging the drive. The voltage produced by the permanent magnet motor magnets is proportional to speed. For high speed operation the drive must apply currents to the motor to counter-act the flux produced by the magnets. It is possible to operate the motor at very high speeds

Safety information	Product information	Mechanical installation	Electrical installation	Getting started	Basic parameters	Running the motor	Optimization	Drive communication	NV Media Card Operation	Onboard PLC	Advanced parameters	Diagnostics	UL information
--------------------	---------------------	-------------------------	-------------------------	-----------------	------------------	-------------------	--------------	---------------------	-------------------------	-------------	---------------------	-------------	----------------

that would give a very high motor terminal voltage, but this voltage is prevented by the action of the drive.

If however, the drive is disabled (or tripped) when the motor voltages would be higher than the rating of the drive without the currents to counter-act the flux from the magnets, it is possible to damage the drive. If high speed mode is enabled the motor speed must be limited to the levels given in the table below unless an additional hardware protection system is used to limit the voltages applied to the drive output terminals to a safe level.

Drive voltage rating	Maximum motor speed (rpm)	Maximum safe line to line voltage at the motor terminals (V rms)
200	$400 \times 1000 / (K_e \times \sqrt{2})$	$400 / \sqrt{2}$
400	$800 \times 1000 / (K_e \times \sqrt{2})$	$800 / \sqrt{2}$
575	$955 \times 1000 / (K_e \times \sqrt{2})$	$955 / \sqrt{2}$
690	$1145 \times 1000 / (K_e \times \sqrt{2})$	$1145 / \sqrt{2}$

K_e is the ratio between r.m.s. line to line voltage produced by the motor and the speed in V/1000 rpm. Care must also be taken not to demagnetize the motor. The motor manufacturer should always be consulted before using this mode.

By default, high speed operation is disabled (Pr **05.022** = 0).

It is also possible to enable high speed operation and allow the drive to automatically limit the motor speed to the levels specified in the table and generate an *Overspeed.1* trip if the level is exceeded (Pr **05.022** = -1).

8.6.4 Switching frequency

With a default switching frequency of 3 kHz the maximum output frequency should be limited to 250 Hz. Ideally a minimum ratio of 12:1 should be maintained between the switching frequency and the output frequency. This ensures the number of switchings per cycle is sufficient to ensure the output waveform quality is maintained at a minimum level. If this is not possible, quasi-square switching should be enabled (Pr **05.020** =1). The output waveform will be quasi square above base speed ensuring a symmetrical output waveform, which results in a better quality output than would otherwise result.

8.6.5 Maximum speed / frequency

In all operating modes (Open loop, RFC-A and RFC-S) the maximum output frequency is limited to 550 Hz. However, in RFC-S mode the speed is also limited by the voltage constant (K_e) of the motor. K_e is a specific constant for the servo motor being used. It can normally be found on the motor data sheet in V/k rpm (volts per 1,000 rpm).

8.6.6 Quasi-Square wave (open-loop only)

The maximum output voltage level of the drive is normally limited to an equivalent of the drive input voltage minus voltage drops within the drive (the drive will also retain a few percent of the voltage in order to maintain current control). If the motor rated voltage is set at the same level as the supply voltage, some pulse deletion will occur as the drive output voltage approaches the rated voltage level. If Pr **05.020** (Quasi-square wave enable) is set to 1 the modulator will allow over modulation, so that as the output frequency increases beyond the rated frequency the voltage continues to increase above the rated voltage. The modulation depth will increase beyond unity; first producing trapezoidal and then quasi-square waveforms.

This can be used for example:

- To obtain high output frequencies with a low switching frequency which would not be possible with space vector modulation limited to unity modulation depth,

or

- In order to maintain a higher output voltage with a low supply voltage.

The disadvantage is that the machine current will be distorted as the modulation depth increases above unity, and will contain a significant amount of low order odd harmonics of the fundamental output frequency.

The additional low order harmonics cause increased losses and heating in the motor.

9 Drive communication

This section details the communication protocols supported on the drives.

The drive is supplied with either an Ethernet interface (Unidrive M700 / M702), or an EIA 485 serial communication interface (Unidrive M701).

For more information on the parameters associated with each interface and the connection details please refer to section 5.12 *Communications* on page 46.

9.1 CT Modbus RTU specification (Unidrive M701)

This section describes the adaptation of the MODBUS RTU protocol offered on Control Techniques' products. The portable software class which implements this protocol is also defined.

MODBUS RTU is a master slave system with half-duplex message exchange. The Control Techniques (CT) implementation supports the core function codes to read and write registers. A scheme to map between MODBUS registers and CT parameters is defined. The CT implementation also defines a 32 bit extension to the standard 16 bit register data format.

9.1.1 MODBUS RTU

Physical layer

Attribute	Description
Normal physical layer for multi-drop operation	EIA 485 2 wire
Bit stream	Standard UART asynchronous symbols with Non Return to Zero (NRZ)
Symbol	Each symbol consists of:- 1 start bit 8 data bits (transmitted least significant bit first) 2 stop bits*
Baud rates	300, 600, 1200, 2400, 4800, 9600, 19200, 38400, 57600, 76800, 115200

* The drive will accept a packet with 1 or 2 stop bits but will always transmit 2 stop bits

RTU framing

The frame has the following basic format

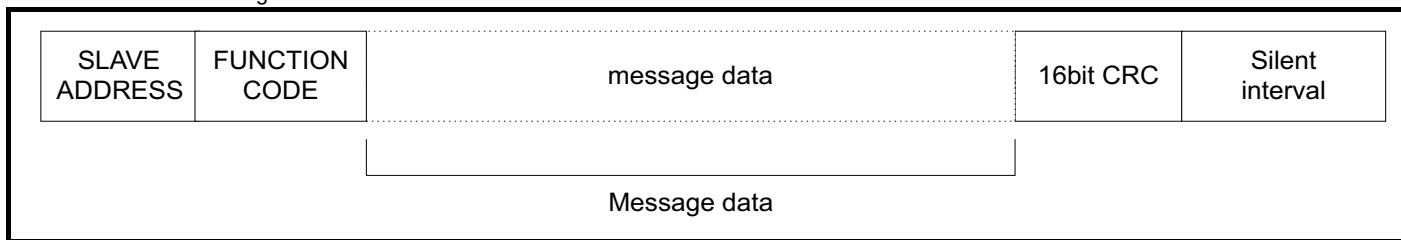

The frame is terminated with a minimum silent period of 3.5 character times (for example, at 19200 baud the minimum silent period is 2 ms). Nodes use the terminating silence period to detect the end of frame and begin frame processing. All frames must therefore be transmitted as a continuous stream without any gaps greater or equal to the silence period. If an erroneous gap is inserted then receiving nodes may start frame processing early in which case the CRC will fail and the frame will be discarded.

MODBUS RTU is a master slave system. All master requests, except broadcast requests, will lead to a response from an individual slave. The slave will respond (i.e. start transmitting the response) within the quoted maximum slave response time (this time is quoted in the data sheet for all Nidec Industrial Automation's products). The minimum slave response time is also quoted but will never be less than the minimum silent period defined by 3.5 character times.

If the master request was a broadcast request then the master may transmit a new request once the maximum slave response time has expired.

The master must implement a message time out to handle transmission errors. This time out period must be set to the maximum slave response time + transmission time for the response.

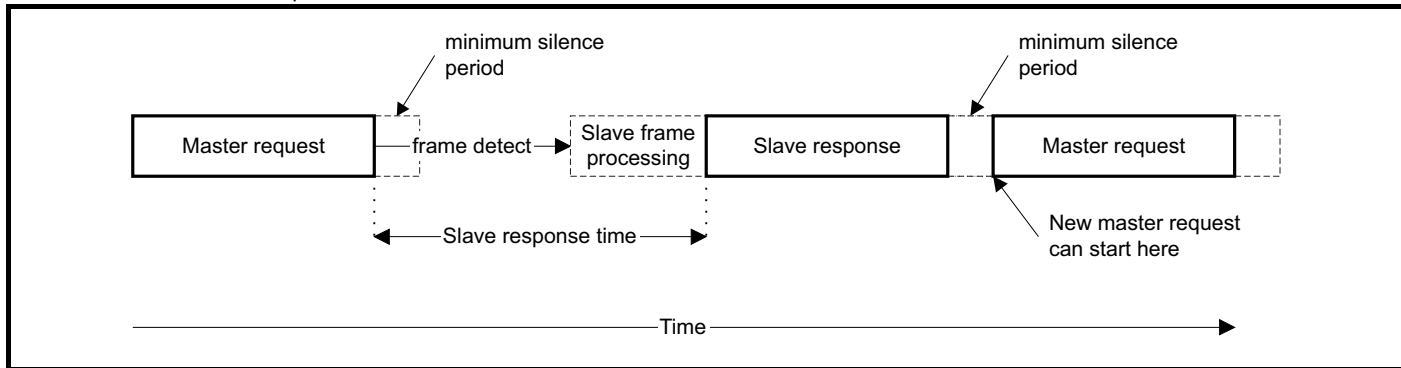

Safety information	Product information	Mechanical installation	Electrical installation	Getting started	Basic parameters	Running the motor	Optimization	Drive communication	NV Media Card Operation	Onboard PLC	Advanced parameters	Diagnostics	UL information
--------------------	---------------------	-------------------------	-------------------------	-----------------	------------------	-------------------	--------------	---------------------	-------------------------	-------------	---------------------	-------------	----------------

9.1.2 Slave address

The first byte of the frame is the slave node address. Valid slave node addresses are 1 through 247 decimal. In the master request this byte indicates the target slave node; in the slave response this byte indicates the address of the slave sending the response.

Global addressing

Address zero addresses all slave nodes on the network. Slave nodes suppress the response messages for broadcast requests.

9.1.3 MODBUS registers

The MODBUS register address range is 16 bit (65536 registers) which at the protocol level is represented by indexes 0 through 65535.

PLC registers

Modicon PLCs typically define 4 register 'files' each containing 65536 registers. Traditionally, the registers are referenced 1 through 65536 rather than 0 through 65535. The register address is therefore decremented on the master device before passing to the protocol.

File type	Description
1	Read only bits ("coil")
2	Read / write bits ("coil")
3	Read only 16bit register
4	Read / write 16bit register

The register file type code is NOT transmitted by MODBUS and all register files can be considered to map onto a single register address space. However, specific function codes are defined in MODBUS to support access to the "coil" registers.

All standard drive parameters are mapped to register file '4' and the coil function codes are not required.

CT parameter mapping

The Modbus register address is 16 bits in size, of which the upper two bits are used for data type selection leaving 14 bits to represent the parameter address, taking into account the slave increments the address value by 1, this results in a theoretical maximum parameter address of 163.84 (limited to 162.99 in software) when the default standard addressing mode (see *Serial Mode* (11.024)) is used.

To access a parameter number above 99 in any drive menu then the modified addressing mode must be used (see *Serial Mode* (11.024)), this will allow access to parameter numbers up to 255 but also limit the maximum menu number to 63.

The Modbus slave device increments the register address by 1 before processing the command, this effectively prevents access to parameter Pr 00.000 in the drive or option module.

The table below shows how the start register address is calculated for both addressing modes.

Parameter	Addressing mode	Protocol register			
0.mm.ppp	Standard	mm x 100 + ppp - 1			
	Modified	mm x 256 + ppp - 1			
Examples					
		16-bit		32-bit	
		Decimal	Hex (0x)	Decimal	Hex (0x)
0.01.021	Standard	120	00 78	16504	40 78
	Modified	276	01 14	16660	41 14
0.01.000	Standard	99	00 63	16483	40 63
	Modified	255	00 FF	16639	40 FF
0.03.161	Standard	N/A	N/A	N/A	N/A
	Modified	928	03 A0	17312	43 A0

Data types

The MODBUS protocol specification defines registers as 16 bit signed integers. All CT devices support this data size.

Refer to the section 9.1.7 *Extended data types* on page 114 for detail on accessing 32 bit register data.

9.1.4 Data consistency

All CT devices support a minimum data consistency of one parameter (16 bit or 32 bit data). Some devices support consistency for a complete multiple register transaction.

9.1.5 Data encoding

MODBUS RTU uses a 'big-endian' representation for addresses and data items (except the CRC, which is 'little-endian'). This means that when a numerical quantity larger than a single byte is transmitted, the MOST significant byte is sent first. So for example

16 - bits 0x1234 would be 0x12 0x34

32 - bits 0x12345678 would be 0x12 0x34 0x56 0x78

9.1.6 Function codes

The function code determines the context and format of the message data. Bit 7 of the function code is used in the slave response to indicate an exception.

Safety information	Product information	Mechanical installation	Electrical installation	Getting started	Basic parameters	Running the motor	Optimization	Drive communication	NV Media Card Operation	Onboard PLC	Advanced parameters	Diagnostics	UL information
--------------------	---------------------	-------------------------	-------------------------	-----------------	------------------	-------------------	--------------	---------------------	-------------------------	-------------	---------------------	-------------	----------------

The following function codes are supported:

Code	Description
3	Read multiple 16 bit registers
6	Write single register
16	Write multiple 16 bit registers
23	Read and write multiple 16 bit registers

FC03 Read multiple

Read a contiguous array of registers. The slave imposes an upper limit on the number of registers, which can be read. If this is exceeded the slave will issue an exception code 2.

Table 9-1 Master request

Byte	Description
0	Slave destination node address 1 through 247, 0 is global
1	Function code 0x03
2	Start register address MSB
3	Start register address LSB
4	Number of 16 bit registers MSB
5	Number of 16 bit registers LSB
6	CRC LSB
7	CRC MSB

Table 9-2 Slave response

Byte	Description
0	Slave source node address
1	Function code 0x03
2	Length of register data in read block (in bytes)
3	Register data 0 MSB
4	Register data 0 LSB
3+byte count	CRC LSB
4+byte count	CRC MSB

FC06 Write single register

Writes a value to a single 16 bit register. The normal response is an echo of the request, returned after the register contents have been written. The register address can correspond to a 32 bit parameter but only 16 bits of data can be sent.

Table 9-3 Master request

Byte	Description
0	Slave node address 1 through 247, 0 is global
1	Function code 0x06
2	Register address MSB
3	Register address LSB
4	Register data MSB
5	Register data LSB
6	CRC LSB
7	CRC MSB

Table 9-4 Slave response

Byte	Description
0	Slave source node address
1	Function code 0x06
2	Register address MSB
3	Register address LSB
4	Register data MSB
5	Register data LSB
6	CRC LSB
7	CRC MSB

FC16 Write multiple

Writes a contiguous array of registers. The slave imposes an upper limit on the number of registers which can be written. If this is exceeded the slave will discard the request and the master will time out.

Table 9-5 Master request

Byte	Description
0	Slave node address 1 through 247, 0 is global
1	Function code 0x10
2	Start register address MSB
3	Start register address LSB
4	Number of 16 bit registers MSB
5	Number of 16 bit registers LSB
6	Length of register data to write (in bytes)
7	Register data 0 MSB
8	Register data 0 LSB
7+byte count	CRC LSB
8+byte count	CRC MSB

Table 9-6 Slave response

Byte	Description
0	Slave source node address
1	Function code 0x10
2	Start register address MSB
3	Start register address LSB
4	Number of 16 bit registers written MSB
5	Number of 16 bit registers written LSB
6	CRC LSB
7	CRC MSB

FC23 Read/Write multiple

Writes and reads two contiguous arrays of registers. The slave imposes an upper limit on the number of registers which can be written. If this is exceeded the slave will discard the request and the master will time out.

Table 9-7 Master request

Byte	Description
0	Slave node address 1 through 247, 0 is global
1	Function code 0x17
2	Start register address to read MSB
3	Start register address to read LSB
4	Number of 16 bit registers to read MSB
5	Number of 16 bit registers to read LSB
6	Start register address to write MSB
7	Start register address to write LSB
8	Number of 16 bit registers to write MSB
9	Number of 16 bit registers to write LSB
10	Length of register data to write (in bytes)
11	Register data 0 MSB
12	Register data 0 LSB
11+byte count	CRC LSB
12+byte count	CRC MSB

Safety information	Product information	Mechanical installation	Electrical installation	Getting started	Basic parameters	Running the motor	Optimization	Drive communication	NV Media Card Operation	Onboard PLC	Advanced parameters	Diagnostics	UL information
--------------------	---------------------	-------------------------	-------------------------	-----------------	------------------	-------------------	--------------	---------------------	-------------------------	-------------	---------------------	-------------	----------------

Table 9-8 Slave response

Byte	Description
0	Slave source node address
1	Function code 0x17
2	Length of register data in read block (in bytes)
3	Register data 0 MSB
4	Register data 0 LSB
3+byte count	CRC LSB
4+byte count	CRC MSB

9.1.7 Extended data types

Standard MODBUS registers are 16bit and the standard mapping maps a single #X.Y parameter to a single MODBUS register. To support 32 bit data types (integer and float) the MODBUS multiple read and write services are used to transfer a contiguous array of 16bit registers.

Slave devices typically contain a mixed set of 16 bit and 32 bit registers. To permit the master to select the desired 16 bit or 32 bit access the top two bits of the register address are used to indicate the selected data type.

NOTE

The selection is applied for the whole block access.

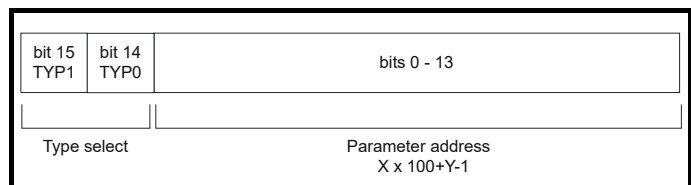

The 2 bit type field selects the data type according to the table below:

Type field bits 15-14	Selected data type	Comments
00	INT16	backward compatible
01	INT32	
10	Float32	IEEE754 standard Not supported on all slaves
11	Reserved	

If a 32 bit data type is selected then the slave uses two consecutive 16 bit MODBUS registers (in 'big endian'). The master must also set the correct 'number of 16 bit registers'.

Example, read Pr 20.021 through Pr 20.024 as 32 bit parameters using FC03 from node 8:

Table 9-9 Master request

Byte	Value	Description
0	0x08	Slave destination node address
1	0x03	FC03 multiple read
2	0x47	Start register address Pr 20.021
3	0xE4	(16384 + 2021 - 1) = 18404 = 0x47E4
4	0x00	Number of 16bit registers to read
5	0x08	Pr 20.021 through Pr 20.024 is 4x32 bit registers = 8x16 bit registers
6	CRC LSB	
7	CRC MSB	

Table 9-10 Slave response

Byte	Value	Description
0	0x08	Slave destination node address
1	0x03	FC03 multiple read
2	0x10	Length of data (bytes) = 4x32 bit registers = 16 bytes
3-6		Pr 20.021 data
7-10		Pr 20.022 data
11-14		Pr 20.023 data
15-18		Pr 20.024 data
19	CRC LSB	
20	CRC MSB	

Reads when actual parameter type is different from selected

The slave will send the least significant word of a 32 bit parameter if that parameter is read as part of a 16 bit access.

The slave will sign extend the least significant word if a 16 bit parameter is accessed as a 32 bit parameter. The number of 16 bit registers must be even during a 32 bit access.

Example, If Pr 01.028 is a 32 bit parameter with a value of 0x12345678, Pr 01.029 is a signed 16 bit parameter with a value of 0xABCD, and Pr 01.030 is a signed 16 bit parameter with a value of 0x0123.

Read	Start register address	Number of 16 bit registers	Response	Comments
Pr 01.028	127	1	0x5678	Standard 16 bit access to a 32 bit register will return low 16 bit word of truncated data
Pr 01.028	16511*	2	0x12345678	Full 32 bit access
Pr 01.028	16511*	1	Exception 2	Number of words must be even for 32 bit access
Pr 01.029	128	1	0xABCD	Standard 16 bit access to a 32 bit register will return low 16 bit word of data
Pr 01.029	16512*	2	0xFFFFABCD	32 bit access to a 16 bit register will return 32 bit sign extended data
Pr 01.030	16513*	2	0x00000123	32 bit access to a 16 bit register will return 32 bit sign extended data
Pr 01.028 to Pr 01.029	127	2	0x5678, 0xABCD	Standard 16 bit access to a 32 bit register will return low 16 bit word of truncated data
Pr 01.028 to Pr 01.029	16511*	4	0x12345678, 0xFFFFABCD	Full 32 bit access

* Bit 14 is set to allow 32 bit access.

Writes when actual parameter type is different from selected

The slave will allow writing a 32 bit value to a 16 bit parameter as long as the 32 bit value is within the normal range of the 16 bit parameter.

The slave will allow a 16 bit write to a 32 bit parameter. The slave will sign extend the written value, therefore the effective range of this type of write will be -32768 to +32767.

Safety information	Product information	Mechanical installation	Electrical installation	Getting started	Basic parameters	Running the motor	Optimization	Drive communication	NV Media Card Operation	Onboard PLC	Advanced parameters	Diagnostics	UL information
--------------------	---------------------	-------------------------	-------------------------	-----------------	------------------	-------------------	--------------	---------------------	-------------------------	-------------	---------------------	-------------	----------------

Examples, if Pr 01.028 has a range of ±100000, and Pr 01.029 has a range of ±10000.

Write	Start register address	Number of 16bit registers	Data	Comments
Pr 01.028	127	1	0x1234	Standard 16 bit write to a 32bit register. Value written = 0x00001234
Pr 01.028	127	1	0xABCD	Standard 16 bit write to a 32bit register. Value written = 0xFFFFABCD
Pr 01.028	16511	2	0x00001234	Value written = 0x00001234
Pr 01.029	128	1	0x0123	Value written = 0x0123
Pr 01.029	16512	2	0x00000123	Value written = 0x00000123

* Bit 14 is set to allow 32 bit access

9.1.8 Exceptions

The slave will respond with an exception response if an error is detected in the master request. If a message is corrupted and the frame is not received or the CRC fails then the slave will not issue an exception. In this case the master device will time out. If a write multiple (FC16 or FC23) request exceeds the slave maximum buffer size then the slave will discard the message. No exception will be transmitted in this case and the master will time out.

Exception message format

The slave exception message has the following format.

Byte	Description
0	Slave source node address
1	Original function code with bit 7 set
2	Exception code
3	CRC LSB
4	CRC MSB

Exception codes

The following exception codes are supported.

Code	Description
1	Function code not supported
2	Register address out of range, or request to read too many registers

Parameter over range during block write FC16

The slave processes the write block in the order the data is received. If a write fails due to an out of range value then the write block is terminated. However, the slave does not raise an exception response, rather the error condition is signalled to the master by the number of successful writes field in the response.

Parameter over range during block read/write FC23

There will be no indication that there has been a value out of range during a FC23 access.

9.1.9 CRC

The CRC is a 16 bit cyclic redundancy check using the standard CRC-16 polynomial $x^{16} + x^{15} + x^2 + 1$. The 16 bit CRC is appended to the message and transmitted LSB first.

The CRC is calculated on ALL the bytes in the frame.

9.1.10 Device compatibility parameters

All devices have the following compatibility parameters defined:

Parameter	Description
Device ID	Unique device identification code
Minimum slave response time	The minimum delay between the end of a message from the master and the time at which the master is ready to receive a response from the slave. Refer to Pr 11.029 (<i>Minimum Comms Transmit Delay</i>).
Maximum slave response time	When global addressing, the master must wait for this time before issuing a new message. In a network of devices, the slowest time must be used.
Maximum baud rate	
32 bit float data type supported	If this data type is not supported then an over range error will be raised if this data type is used.
Maximum buffer size	Determines the maximum block size.

9.2 Ethernet communication (Unidrive M700 / M702)

This section describes the adaptation of the Ethernet interface offered on the Unidrive M700 and M702 drives. The portable software class which implements this protocol is also defined.

9.2.1 Features

The following list gives an overview of the functionality available:

- Dual RJ45 connectivity with support for shielded twisted pair.
- 100 Mbs Ethernet with auto-negotiation.
- Full and half duplex operation with auto-negotiation.
- Auto crossover detection.
- TCP/IP.
- Modbus TCP/IP.
- EtherNet/IP or Profinet IO.
- Switch or Gateway mode.
- VLAN tagging.
- SyPTPro.
- Unidrive M Connect.
- Machine Control Studio.
- Static IP configuration or DHCP client.
- Non-cyclic data transfer with user program.
- Up to 3 transmit and 3 receive cyclic links (easy mode).
- IEEE1588 Precision Time Protocol synchronization.
- RTMoE (Real Time Motion over Ethernet).

9.2.2 Backup/auxiliary supply

Some drives provide a method of powering up the control circuits (and therefore any option module installed) if the AC supply is removed, this allows Ethernet communication to continue operating when the main AC supply is switched off.

9.2.3 Network design considerations

Ethernet is an open system allowing many different vendors to design and supply equipment. When designing an industrial network you must carefully consider the topology and data traffic on the network to avoid potential problems.

Safety information	Product information	Mechanical installation	Electrical installation	Getting started	Basic parameters	Running the motor	Optimization	Drive communication	NV Media Card Operation	Onboard PLC	Advanced parameters	Diagnostics	UL information
--------------------	---------------------	-------------------------	-------------------------	-----------------	------------------	-------------------	--------------	----------------------------	-------------------------	-------------	---------------------	-------------	----------------

To avoid bandwidth issues it is recommended that the control network is logically separate from any other network. Where possible a physically separate network should be used. If this is not possible, the use of managed network devices should be considered to prevent unnecessary traffic such as broadcasts reaching the control network.

NOTE The use of un-switched hubs is not supported.

9.2.4 Addressing

The addressing system used on Ethernet uses two essential numbers for making connection, these are the IP address and the subnet mask. The address allows a specific device to be located and the subnet mask defines how many bits represent the subnet part of the address and how many bits represent the node address (see section 9.2.7 *Generating the complete address* on page 116). Generally devices on different subnets can only communicate by using a gateway (typically a router or firewall).

9.2.5 Where do IP addresses come from?

Every address on a network must be unique. If you do not connect your network to any other networks the assignment of IP addresses is not critical (although using a standard system is recommended), as you have full control of the addresses used. The issue of addressing becomes important when connecting multiple networks together or connecting to the Internet where there is a strong possibility of duplication of addresses if a scheme is not followed.

9.2.6 Addressing etiquette

The following list details some points that should be considered when selecting addresses:

- **Reserve address space:** Ensure you have enough reserve address space on your chosen addressing scheme to allow for future expansion.
- **Uniqueness:** Ensure your addresses are unique, every device on a subnet must have a unique address.
- **Avoid reserved addresses:** For example the address 127.0.0.1 is reserved as the loop back address.
- **Broadcast and system addresses:** The highest and lowest host address on a subnet are reserved addresses.
- **Use a system:** Have a scheme for assigning your addresses, for example typically servers may have a low IP address and routers a high IP address. It is not necessary to allocate consecutive IP addresses so it is possible to reserve ranges for specific uses such as servers, work stations or routers.

9.2.7 Generating the complete address

A complete IP address consists of an IP address and a subnet mask, these two numbers are required to allow communication on Ethernet using TCP/IP.

The IP address

The IP address is made up from four 8 bit decimal numbers (*octets*) and is written as follows:

w.x.y.z for example 192.168.0.1

The subnet mask

The subnet mask defines what part of the address constitutes the subnet within the IP address and what part of the address constitutes the host address. The subnet mask is bit-wise ANDed with the address to give the subnet to which the host belongs. A typical subnet mask would be 255.255.255.0, this may alternatively be written as '/24' as in the example below, showing an IP address of 192.168.0.1 with a subnet mask of 255.255.255.0. This alternative notation indicates the number of bits representing the subnet part of the address, starting from the most significant bit.

Alternative subnet mask notation: 192.168.0.1 /24

Completing the address

To determine which part of the address constitutes the network address and which part constitutes the node address, the IP address is bit-wise ANDed with the subnet mask. Figure 9-1 shows how the IP address and subnet mask are used to determine the subnet address and the host address.

Figure 9-1 Completing the address

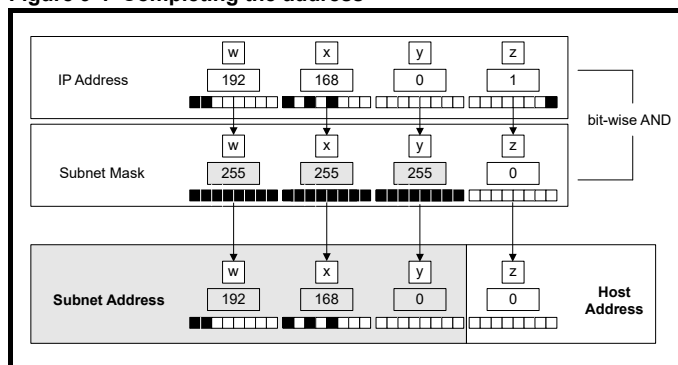

9.2.8 DHCP considerations

Using fixed IP addressing

Using fixed IP addresses (*manually configured*) means that if a module fails, the IP address can be restored to a replacement module without the need to reconfigure the DHCP server. Using fixed addresses also prevents the DHCP server from changing the address. When using fixed IP addresses, it is vital that the IP address is reserved on the DHCP server to prevent duplicate addressing.

NOTE If using manual IP address configuration please note that the IP address subnet mask and the default gateway must also be set manually.

NOTE In Profinet mode, Pr 4.02.004 (*DHCP Enable*) will be forced off on initialisation.

9.2.9 Basic principles of routing

Routing is required to get TCP/IP packets from one subnet to another. In an IP network, nodes from one subnet cannot communicate directly with nodes on a different subnet. To allow nodes to communicate, a router (or similar device) is required to allow the two subnets to exchange data. This means that any node wishing to communicate with a node that is not on its own subnet, must know the address of a router that is on its own subnet. This is sometimes called a gateway or default gateway.

9.3 CT Modbus TCP/IP specification (Unidrive M700 / M702)

Modbus TCP/IP

Modbus TCP/IP is one of the most widely supported industrial Ethernet based protocols offering the functionality and simplicity of the Modbus protocol, with the flexibility of Ethernet. Table 9-11 shows the supported Modbus function codes.

Modbus TCP/IP uses the standard Modbus RTU Protocol Data Unit (PDU) but without the CRC bytes and encapsulates it within a Modbus TCP/IP Application Data Unit (ADU) for transmission. This means that the Modbus PDU is the same for both standard (RTU) and Ethernet based transmission.

Table 9-11 Supported Modbus function codes

Code	Description
3	Read multiple 16 bit registers.
6	Write single 16 bit register.
16	Write multiple 16 bit registers.
23	Read and write multiple 16 bit registers.

9.3.1 Data structure

Communication between devices is based upon Modbus Application Data Units (ADUs), the ADU consists of 2 parts, the Modbus Application Protocol (MBAP) header and the Modbus Protocol Data Unit (PDU).

Figure 9-2 Modbus Data Structure

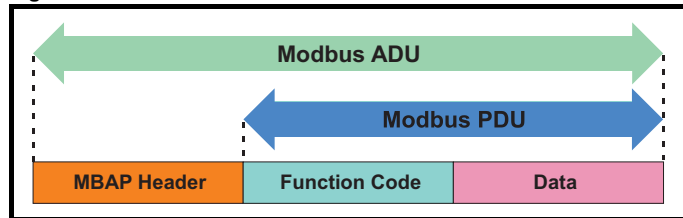

Table 9-12 MBAP Header

Field	Length (Bytes)	Description
Transaction Identifier	2	Uniquely identifies the transaction (0 to 65535)
Protocol Identifier	2	Identifies the protocol (0 = Modbus)
Length	2	Number of following bytes in the message
Unit Identifier	1	Uniquely identifies the destination node (0 to 255)

The unit identifier within the MBAP header is used to identify whether the destination node is the host drive or an option module (not available on the onboard Ethernet interface with firmware versions prior to V01.02.01.10).

Table 9-13 MBAP Unit Identifier

Unit Identifier	Destination
0 or 255	Drive
1	Slot 1
2	Slot 2
3	Slot 3
4	Slot 4 (onboard Ethernet)
254	Self

9.3.2 Data access

Data access using Modbus TCP/IP takes the form of a request for data by the master, followed by a response from the slave indicating success or failure. If no response is received this indicates that the message has not been received or the message is invalid or the node is unable to reply.

Each drive or option module parameter is internally mapped to a single 16-bit Modbus register, all Modbus function codes access 16-bit registers only. To access a 32-bit parameter, two contiguous Modbus registers must be specified in the request and the 32-bit data access scheme must be used.

9.3.3 32-bit data access

Standard Modbus registers are 16 bits in size and reference a single drive/option module parameter. To access a 32-bit data value the multiple read/write services must be used to transfer a contiguous array of 16-bit registers. To instruct the client to select either 16-bit or 32-bit access bit 14 of the register address is used.

NOTE Bit b15 of the register address is reserved for future use.

Figure 9-3 Data type selection

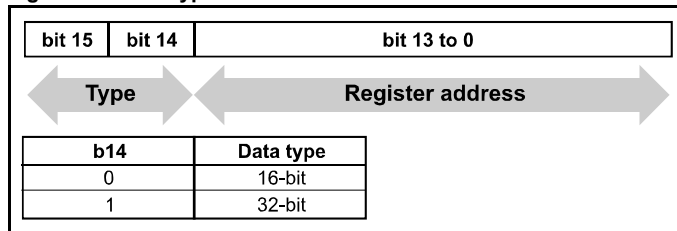

If 32-bit data type is selected then this effectively adds 16384 (0x4000) to the start register address.

e.g. For drive parameter Pr **01.021** in standard addressing mode, the start register value is 16384 + 120 = 16504 (0x4078)

9.3.4 Supported Modbus function codes

The following table details the supported Modbus function codes.

Table 9-14 Supported Modbus function codes

Function Code		Description
Decimal	Hex (0x)	
3	03	Read multiple 16-bit registers
6	06	Write single 16-bit register
16	10	Write multiple 16-bit registers
23	17	Read and write multiple 16-bit registers

9.3.5 Register addressing

The Modbus register address is 16 bits in size, of which the upper two bits are used for data type selection leaving 14 bits to represent the parameter address, taking into account the slave increments the address value by 1, this results in a theoretical maximum parameter address of 163.84 (limited to 162.99 in software) when the default standard addressing mode (see *Modbus Register Addressing Mode (S.15.013)*) is used.

To access a parameter number above 99 then the modified addressing mode must be used (see *Modbus Register Addressing Mode (S.15.013)*), this will allow access to parameter numbers up to 255 but also limit the maximum menu number to 63.

NOTE A reset is not required to activate the change, the addressing mode is effectively made active immediately on changing.

The Modbus slave device increments the register address by 1 before processing the command, this effectively prevents access to parameter Pr **00.000** in the drive or option module.

The Table 9-15 shows how the start register address is calculated for both addressing modes.

Safety information	Product information	Mechanical installation	Electrical installation	Getting started	Basic parameters	Running the motor	Optimization	Drive communication	NV Media Card Operation	Onboard PLC	Advanced parameters	Diagnostics	UL information
--------------------	---------------------	-------------------------	-------------------------	-----------------	------------------	-------------------	--------------	---------------------	-------------------------	-------------	---------------------	-------------	----------------

Table 9-15 Start register addressing

CT Parameter	Addressing mode	Protocol register			
s.mm.ppp	Standard	mm * 100 + ppp - 1			
	Modified	mm * 256 + ppp - 1			
Examples					
		16-bit		32-bit	
		Decimal	Hex (0x)	Decimal	Hex (0x)
0.01.021	Standard	120	00 78	16504	40 78
	Modified	276	01 14	16660	41 14
0.01.000	Standard	99	00 63	16483	40 63
	Modified	255	00 FF	16639	40 FF
3.70.001	Standard	7000	1B 58	23384	5B 58
	Modified	N/A	N/A	N/A	N/A
0.03.161	Standard	N/A	N/A	N/A	N/A
	Modified	928	03 A0	17312	43 A0

9.3.6 FC03 – Read multiple registers

This function code allows a contiguous array of registers to be read. The maximum number of registers that can be read is 120, this allows up to 120 16-bit parameters or 60 32-bit parameters to be read in a single transaction. If this is exceeded the server will issue an exception response code 2.

Master request data

Byte	Description
7	Function code 0x03
8	Start register address (MSB)
9	Start register address (LSB)
10	Number of 16-bit registers (MSB)
11	Number of 16-bit registers (LSB)

Slave response data

Byte	Description
7	Function code 0x03
8	Length of data in read block (Bytes)
9	Register data (MSB)
10	Register data (LSB)

The normal response includes the function code, number of data bytes in the read block followed by the register data (unless an exception occurs).

If 32-bit parameter addressing is used, then for each parameter read:

- Two 16-bit registers must be used in the request
- The register data in the response will contain 4 bytes of data

Example

To read drive parameters **0.20.021** to **0.20.023** (transaction ID = 42) with 32-bit data access and standard addressing:

Master request data

Byte	Hex value	Description
0-1	00 2A	Transaction ID (42)
2-3	00 00	Protocol ID (0=TCP/IP)
4-5	00 06	Length (Bytes=6)
6	FF	Unit identifier (FF= Drive)
7	03	Function code (3)
8-9	47 E4	Start register (20.20)
10-11	00 06	Number of registers (6)

Slave response data

Byte	Hex value	Description
0-1	00 2A	Transaction ID (42)
2-3	00 00	Protocol ID (0=TCP/IP)
4-5	00 0F	Length (Bytes=15)
6	FF	Unit identifier (FF= Drive)
7	03	Function code (3)
8	0C	Data length (Bytes=12)
9-12	?	Pr 0.20.021 data
13-16	?	Pr 0.20.022 data
17-20	?	Pr 0.20.023 data

9.3.7 FC06 – Write single register

This function code writes a single 16-bit value to a register. The normal response is an echo of the request (unless an exception occurs) returned after the parameter has been written.

The register address can be a 32-bit parameter address but only the lower 16 bits of the value will be written.

Master request data

Byte	Description
7	Function code 0x06
8	Start register address (MSB)
9	Start register address (LSB)
10	Register data (MSB)
11	Register data (LSB)

Slave response data

Byte	Description
7	Function code 0x06
8	Start register address (MSB)
9	Start register address (LSB)
10	Register data (MSB)
11	Register data (LSB)

Example

To write the value 12345 to drive parameter **0.20.001** (transaction ID = 42) using standard addressing:

Master request data

Byte	Hex value	Description
0-1	00 2A	Transaction ID (42)
2-3	00 00	Protocol ID (0=TCP/IP)
4-5	00 06	Length (Bytes=6)
6	FF	Unit identifier (FF= Drive)
7	06	Function code (06)
8-9	07 D0	Start register (20.000)
10-11	30 39	Register data (12345)

Slave response data

Byte	Hex value	Description
0-1	00 2A	Transaction ID (42)
2-3	00 00	Protocol ID (0=TCP/IP)
4-5	00 06	Length (Bytes=6)
6	FF	Unit identifier (FF= Drive)
7	06	Function code (6)
8-9	07 D0	Start register (20.000)
10-11	30 39	Register data (12345)

9.3.8 FC16 – Write multiple registers

This function code allows a contiguous series of registers to be written. The maximum number of registers that can be written is 120, this allows up to 120 16-bit parameters or 60 32-bit parameters to be read in a single transaction. If this is exceeded the server will issue an exception response code 2. The normal response includes the function code, start register address and number of 16-bit registers written (unless an exception occurs), returned after the parameters have been written.

Safety information	Product information	Mechanical installation	Electrical installation	Getting started	Basic parameters	Running the motor	Optimization	Drive communication	NV Media Card Operation	Onboard PLC	Advanced parameters	Diagnostics	UL information
--------------------	---------------------	-------------------------	-------------------------	-----------------	------------------	-------------------	--------------	---------------------	-------------------------	-------------	---------------------	-------------	----------------

If 32-bit parameter addressing is used, then for each parameter written:

- Two 16-bit registers must be used in the request
- Four bytes must be specified in the request
- The number of registers written in the response will be twice the number of parameters written

Master request data

Byte	Description
7	Function code 0x10
8	Start register address (MSB)
9	Start register address(LSB)
10	Number of 16-bit registers (MSB)
11	Number of 16-bit registers (LSB)
12	Length of register data to write (Bytes)
13	Register data (MSB)
14	Register data (LSB)

Slave response data

Byte	Description
7	Function code 0x10
8	Start register address (MSB)
9	Start register address (LSB)
10	Number of 16-bit registers written (MSB)
11	Number of 16-bit registers written (LSB)

Example

To write the value 12345 to drive parameters **0.20.021** through **0.20.023** (Transaction ID=42) using standard 32-bit addressing:

Master request data

Byte	Hex value	Description
0-1	00 2A	Transaction ID (42)
2-3	00 00	Protocol ID (0=TCP/IP)
4-5	00 13	Length (Bytes=19)
6	FF	Unit identifier (FF= Drive)
7	10	Function code (16)
8-9	47 E4	Start register (20.020)
10-11	00 06	Number of registers (6)
12	0C	Register data length (Bytes)
13-16	00 00 30 39	Register data 0
17-20	00 00 30 39	Register data 1
21-24	00 00 30 39	Register data 2

Slave response data

Byte	Hex value	Description
0-1	00 2A	Transaction ID (42)
2-3	00 00	Protocol ID (0=TCP/IP)
4-5	00 06	Length (Bytes=6)
6	FF	Unit identifier (FF= Drive)
7	10	Function code (16)
8-9	47 E4	Start register (20.020)
10-11	00 06	Registers written (6)

Master request dataSlave response data

Byte	Description
7	Function code 0x17
8	Start read register address (MSB)
9	Start read register address (LSB)
10	Number of registers to read (MSB)
11	Number of registers to read (LSB)
12	Start write register address (MSB)
13	Start write register address (LSB)
14	Number of registers to write (MSB)
15	Number of registers to write (LSB)
16	Length of register data to write (Bytes)
17	Register data 0 (MSB)
18	Register data 0 (LSB)

Byte	Description
7	Function code 0x17
8	Length of data in read block (Bytes)
9	Register data (MSB)
10	Register data (LSB)

The normal response includes the function code, number of data bytes in the read block followed by the register data (unless an exception occurs).

If 32-bit parameter addressing is used:

- For each parameter read or written, two 16-bit registers must be used in the request
- For each parameter written, four bytes must be specified in the request
- For each parameter read, four bytes of data will be used in the response

9.3.9 FC23 - Read/Write multiple registers

This function code allows a contiguous series of registers to be written and another contiguous series of registers to be read. The maximum number of registers that can be read is 120 and similarly the maximum number of registers that can be written is 120, this allows up to 120 16-bit parameters or 60 32-bit parameters to be read and / or written in a single transaction. If this is exceeded the server will issue an exception response code 2.

Safety information	Product information	Mechanical installation	Electrical installation	Getting started	Basic parameters	Running the motor	Optimization	Drive communication	NV Media Card Operation	Onboard PLC	Advanced parameters	Diagnostics	UL information
--------------------	---------------------	-------------------------	-------------------------	-----------------	------------------	-------------------	--------------	----------------------------	-------------------------	-------------	---------------------	-------------	----------------

Example

To write the value 12345 to drive parameters **0.20.021** through **0.20.023** and read the values of parameters **0.20.024** through **0.20.026** (Transaction ID=42) using standard addressing:

Master request data

Byte	Hex value	Description
0-1	00 2A	Transaction ID (42)
2-3	00 00	Protocol ID (0=TCP/IP)
4-5	00 17	Length (Bytes=6)
6	FF	Unit identifier (FF= Drive)
7	17	Function code (23)
8-9	47 E7	Start read register (20.023)
10-11	00 06	Number of read registers (6)
12-13	47 E4	Start write register (20.020)
14-15	00 06	Number of write registers (6)
16	0C	Length of register data to write (Bytes=12)
17-20	00 00 30 39	Register data 0 (12345)
21-24	00 00 30 39	Register data 1 (12345)
25-28	00 00 30 39	Register data 2 (12345)

Slave response data

Byte	Hex value	Description
0-1	00 2A	Transaction ID (42)
2-3	00 00	Protocol ID (0=TCP/IP)
4-5	00 0F	Length (Bytes=15)
6	FF	Unit identifier (FF= Drive)
7	17	Function code (23)
8	0C	Length of data (Bytes=12)
9-12	?? ?? ?? ??	Register data 0 (Pr 20.024)
13-16	?? ?? ?? ??	Register data 1 (Pr 20.025)
17-20	?? ?? ?? ??	Register data 2 (Pr 20.026)

9.3.10 Modbus Exception Response Message

If the master request is rejected then an exception response message will be returned.

Exception Response Message

Byte	Hex value	Description
0-1	?? ??	Transaction ID (defined by Modbus Master)
2-3	00 00	Protocol ID
4-5	00 03	Number of data bytes to follow
6	??	Unit identifier
7	??	Function code (request FC with bit b7 set to 1)
8	??	Exception code 01 = Function code not supported 02 = Invalid register address

The master request function code will be returned but with bit b7 set (e.g. function code 0x03 will be returned as 0x83).

Safety information	Product information	Mechanical installation	Electrical installation	Getting started	Basic parameters	Running the motor	Optimization	Drive communication	NV Media Card Operation	Onboard PLC	Advanced parameters	Diagnostics	UL information
--------------------	---------------------	-------------------------	-------------------------	-----------------	------------------	-------------------	--------------	---------------------	-------------------------	-------------	---------------------	-------------	----------------

9.4 RTMoE (Real Time Motion over Ethernet) (Unidrive M700 / M702)

This is a communication protocol developed to provide Ethernet synchronisation and data transfer between Control Techniques drives.

RTMoE provides:

- Drive synchronization using the Precision Time Protocol (PTP) otherwise known as IEEE1588 V2
Each PTP device has a tuneable clock running. Following an arbitration process the devices select a master and tune their clocks until they are synchronized to that master. This process may take several seconds to complete.
- Data transfer
 - Cyclic data (synchronous and non-synchronous) is sent using the User Datagram Protocol (UDP)
 - Non-cyclic data is sent using the Transmission Control Protocol (TCP)
- Cycle time down to 250 µs (Using Machine Control Studio)
- Jitter less than 1 µs

RTMoE can be configured in two ways:

- Via Machine Control Studio using the Advanced link editor or
- Via parameters using the Easy Mode menus (10 and 11)

The full capabilities of RTMoE are available only when using Machine Control Studio.

Table 9-16 shows the comparison between Easy Mode and Machine Control Studio support levels.

Table 9-16 RTMoE Support levels

Capability	Support Level	
	Easy Mode	Machine Control Studio ^{(1) (3)}
Non-cyclic communication	No	Yes
Total number of transmit cyclic links	3	11
Total number of receive cyclic links	3	11
Max transmit synchronous links	1	1
Max receive synchronous links	1	1
Max length of non-synchronous link	10 x 32-bit	10 x 32-bit ⁽²⁾
Max length of synchronous link	3 x 32-bit	3 x 32-bit
Minimum transmission period (non-synchronised)	1 ms	1 ms
Maximum transmission period (non-synchronised)	100 ms	100 ms ⁽³⁾
Minimum transmission period (Synchronised)	1 ms	250 µs
Maximum transmission period (Synchronised)	8 ms	8 ms
Synchronised with onboard program	Yes (when cycle time = 4 ms)	Yes (when cycle time = 4 ms)
Max parameter accesses per second	6000	6000
Max messages per second (S.02.004)	8000	8000

(1) MCI2x0 firmware version V01.08.04.06 and later.

(2) Maximum number of parameter in a non-synchronous links between two MCI210 modules (V01.08.04.06 and later) is 20.

(3) Currently the Ethernet interface only supports cyclic links using Easy Mode (Menu 10), cyclic links using Machine Control Studio will be available in a future release of the Ethernet interface firmware.

NOTE The number of cyclic links is limited to a maximum of 2 when accessing the option module internal parameters (e.g. the PLC register menus 7x).

9.4.1 RTMoE Message rate capability

When designing a network, the message loading for each device should be checked to ensure the number of messages do not exceed the maximum recommended value.

Consider the following example where a Unidrive M700 is communicating with three other devices over Ethernet using Modbus TCP/IP (10 parameters read every 100 ms), EtherNet/IP (5 parameters read every 10 ms and 5 parameters written every 10 ms) and RTMoE (2 parameters written every 500 µs).

Protocol	Number of Parameters	Rate	Parameters accessed / second	Message rate / second
Modbus TCP/IP	10 x read	100 ms	100	10
EtherNet/IP	5 x read	10 ms	500	100
	5 x write	10 ms	500	100
RTMoE	2 x write	500 µs	4000	2000
Total			5100	2210
Maximum supported			6000	8000
Within capability?			✓	✓

9.4.2 RTMoE Message type

From the system design, it should be known how many drives will be used and what data needs to be sent where. There are two fundamental ways of sharing data:

- Cyclic data – use cyclic links for important information relating to the dynamic behavior of the machine (e.g. control word, speed reference, etc.)
- Non-cyclic data – used for non time-critical information (e.g. drive setup data) A user program must be used to control the transfer of non-cyclic messages. (see *Non cyclic enable (S.02.035)* and *Non cyclic base parameter (S.02.036)*)

Each cyclic message can be one of three types:

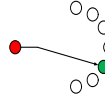
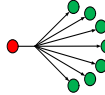
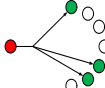
- 1 Unicast – used if data needs to go from one device to another

- 2 Broadcast – used if data needs to go from one device to all other devices

- 3 Multicast – used if data needs to go from one device to a subset of the other devices

By choosing the most appropriate transmission type an efficient and reliable network can be designed.

For example:

- Three drives must use an ELS (Electronic Line Shaft) to follow a Smart Drive. In this case a **multicast** message should be used to transmit the reference position from the Smart Drive.
- Three drives need to return general status information to the Smart Drive. In this case, each drive should send a **unicast** message to the Smart Drive.
- The Smart Drive needs to command all other drives to stop/start. The Smart Drive should use a broadcast message to transmit the command to all the other drives.

Safety information	Product information	Mechanical installation	Electrical installation	Getting started	Basic parameters	Running the motor	Optimization	Drive communication	NV Media Card Operation	Onboard PLC	Advanced parameters	Diagnostics	UL information
--------------------	---------------------	-------------------------	-------------------------	-----------------	------------------	-------------------	--------------	----------------------------	-------------------------	-------------	---------------------	-------------	----------------

NOTE Broadcast messages should be used with care, bottlenecks in the network can be easily created by using broadcast messages, this will reduce the performance of the network and, in extreme situations, seriously impair the system operation.

9.4.3 Checking for bottlenecks

There are three main reasons why a bottleneck occurs:

1. A drive is receiving more Ethernet messages than it can handle (8000 frames per second).
2. A drive is being asked to access more parameters than it can handle (6000 parameters per second).
3. A segment of the network has reached its bandwidth limit.
For a full duplex 100Mbit/sec Ethernet network, assuming all Ethernet messages are the maximum 1500 bytes in length, the bandwidth is 8000 frames/sec in each direction.

NOTE

- It is unrealistic to assume that all messages will be full frames
- In reality the maximum number of frames/sec will be higher
- A more detailed frame analysis may be performed if necessary but the values stated can be used to quickly determine whether bottlenecks could be a problem

9.4.4 RTMoE Message synchronization

Cyclic messages can be synchronized or non-synchronized.

Only one synchronized cyclic link in each direction (one transmit and one receive) is possible so these should only be used for high precision applications where the motion of multiple drives must be closely coupled (e.g. printing applications). All other messages should be sent using a non-synchronized cyclic link.

Synchronized cyclic data links utilise the IEEE1588 clock time distributed across the network. The IEEE1588 clock can synchronize the drive's control loops to within a 1 μ s accuracy, Pr **0.11.002 Option Synchronisation Active** displays the active option slot providing synchronization. With synchronized control loops the Ethernet interface can be used to transfer drive parameters containing motion information, including those from the AMC.

With normal Ethernet there are a number of variables that can impact upon the performance of the network. These include:

- Delays through switches - Ethernet is a switched network and messages are typically copied completely into a switch before being forwarded on. *This is fundamental to modern Ethernet and cannot be influenced by system design.*
- Message length – the longer a message, the longer it will take to transmit and copy into a switch before forwarding it on. For a synchronous cyclic link frame this delay is 12 μ s, for a full Ethernet frame it is 120 μ s.
Message length can be controlled, but to maximise compatibility with other Ethernet traffic, it is sensible to allow for full frame Ethernet messages where possible.
- Length of daisy chain - A daisy chain with Ethernet is really a chain of three port switches.
This can be controlled through physical network design e.g. using a tree structure to limit the length of daisy chains.

The above delays (Latency) are managed in software, in conjunction with PTP, to ensure that all device use synchronous data at the same time, but the length of the daisy chain must be controlled by careful network design.

9.4.5 General guidelines for synchronous cyclic data

The following guidelines provide a simple way of specifying a network supporting synchronous cyclic data that offers accurate synchronization and guaranteed determinism, whilst maintaining compatibility with standard Ethernet traffic.

- Limit daisy chains to 10 drives
- Where more than 10 drives are used, create a tree structure using a switch
- Any Ethernet switches must support IEEE1588 V2
- Segregate the network using VLANs and gateways
- Assign one device to be the synchronization master for each segregated network

9.4.6 Segregating the network

If synchronous cyclic links are used, for best reliability it is sensible to segregate the network. This means:

- Assign one (or more) drive(s) to be a gateway, which ensures messages entering the segregated section are stripped of any existing prioritisation information. (See *Gateway Mode (S.02.025)*)
- Ensure that **VLAN** (Virtual Local Area Network) is enabled on all devices so that synchronous data can be prioritized as it is passed between switches. (See *VLAN Enable (S.02.030)*)
- Use multiple Master Clock Domains. (See *Master Clock Domain (S.11.002)*)

9.4.7 Synchronization master

If a synchronous cyclic link is used then one device must be a synchronous master, if this is an existing 3rd party device then, to minimize the initialization time, all other devices/drives on the network should not be allowed to become the synchronous master. To disable the drive from becoming the synchronous master then set the value in *Preferred Sync Master (S.11.001)* to 0, this ensures the drive does not become the synchronous master.

If there is no existing synchronous master then a suitable drive should be chosen (see *Preferred Sync Master (S.11.001)*), in choosing which drive to be the synchronous master, the physical position of the drives and network layout should be considered so as to minimize the number of switches each message has to pass through.

A typical segregated network using VLANs and gateways consisting of three separate sections of a machine controlled by one master PLC is shown in the following diagram.

Figure 9-4 Typical separately synchronized segregated network

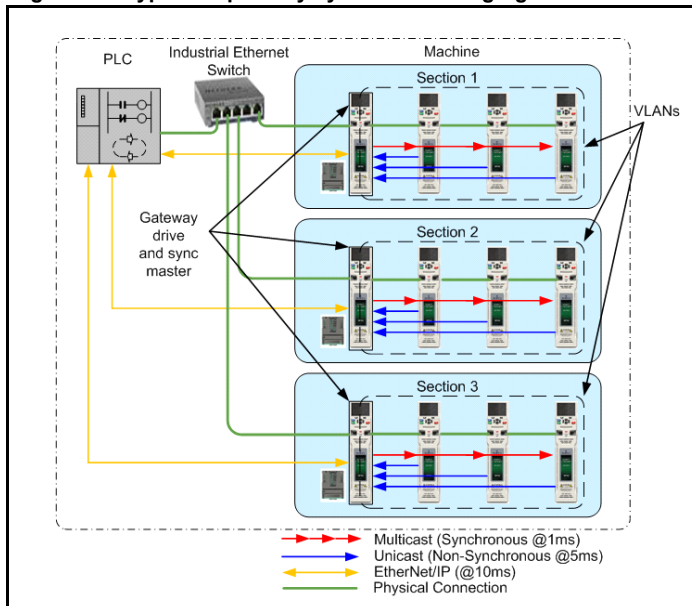

NOTE Configuring a single drive to act as both gateway and synchronization master will increase the message loading on that drive, in some situations this may result in a reduction of the network performance. In these situations, separate drives should be used for the gateway and synchronization master.

NOTE For the gateway mode to operate correctly, the standard Ethernet network must be connected to port 1 on the drive and the real-time Ethernet to port 2 as shown in Figure 9-4.

9.4.8 VLANs

To guarantee the timing of synchronous links VLANs must be enabled using *VLAN Enable (S.02.030)*. VLANs include a priority field that is applied to all messages. This field is used to apply a higher priority to synchronous cyclic data than other non-deterministic traffic.

9.4.9 Parameter Update Rate

Parameters are exchanged over the network. The value exchanged over the network must be exchanged with the drive or option parameter. The rate of data exchange differs for synchronous and non-synchronous cyclic links as well as for drive and option destinations.

The diagram below depicts the update cycles used within the Ethernet interface. Cyclic link mappings being exchanged with the drive will be updated at the background task rate. This rate (*Background cycles per second (S.09.008)*) varies with the load on the Ethernet interface; EtherNet/IP data exchange also takes place in the background task.

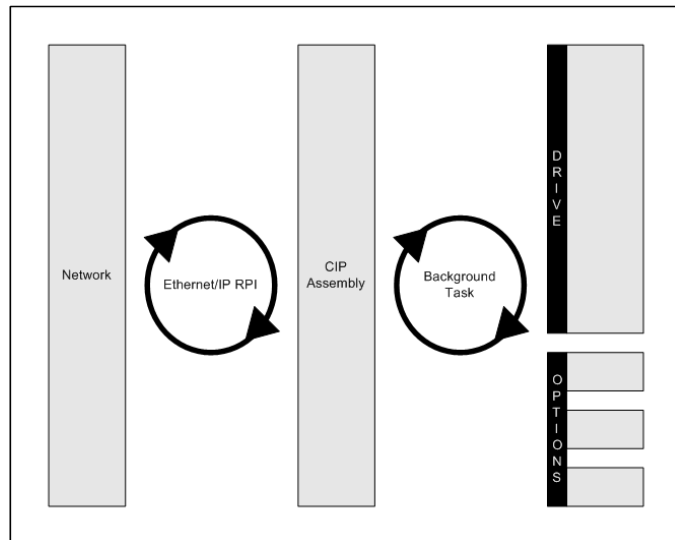

9.5 EtherNet/IP specification (Unidrive M700 / M702)

The Ethernet interface supports the EtherNet/IP protocol and conforms to the EtherNet/IP adaptation of the Common Industrial Protocol (CIP) Specification. This is the same upper-layer protocol and object model as used in DeviceNet.

The Ethernet interface module will operate as a slave device and the following functionality is supported:

- Variable length input assembly object (instance 100) with consistency for up to 32 parameters
- Variable length output assembly object (instance 101) with consistency for up to 32 parameters
- User selectable RPI timeout action
- Identity object (class 0x01)
- Motor data object (class 0x28)
- Control supervisor object (class 0x29)
- AC/DC Drive object (class 0x2A)
- Control Techniques objects (classes 0x64 to 0x69)
- Explicit (non-cyclic) access to parameters

9.5.1 Requested Packet Interval (RPI) timeout

This timeout is defined by the EtherNet/IP protocol and is configured in the PLC master. If enabled, the Ethernet interface will monitor the data traffic once the cyclic data has been established, and if data is not received within the specified time, it will perform the requested action as defined by Pr S.20.011 *RPI timeout action*. This indicates that the interface has detected that the cyclic data communication has been interrupted.

NOTE The RPI timeout action will only occur on a loss of cyclic data message, i.e. after cyclic data has been established and subsequently lost. No action will be taken if no cyclic data has been detected.

Safety information	Product information	Mechanical installation	Electrical installation	Getting started	Basic parameters	Running the motor	Optimization	Drive communication	NV Media Card Operation	Onboard PLC	Advanced parameters	Diagnostics	UL information
--------------------	---------------------	-------------------------	-------------------------	-----------------	------------------	-------------------	--------------	---------------------	-------------------------	-------------	---------------------	-------------	----------------

9.5.2 Read consistency

Under normal conditions, cyclic data is sampled and transmitted at the Requested Packet Interval (RPI). However, if an option module was in the process of modifying the mapped parameters while these parameters were being sampled, then the data transmitted across the network may not be consistent across the entire assembly object. If read consistency is enabled (**S.20.026 In Consistency Enable**) and a trigger parameter specified in *In Consistency Trigger Param* (**S.20.027**) then data will only be sampled and transmitted when the trigger parameter *In Consistency Trigger Param* (**S.20.027**) contains a non-zero value. This trigger parameter will then be set to zero after the data has been sampled.

It is therefore possible, by controlling the trigger parameters, that a user program in the drive or option module can ensure that the values in the cyclic data parameters are not sampled until all values are updated.

Whether consistency is enabled or not, data will always be consistent for an individual parameter, i.e. all 4 bytes of a 32-bit value will be consistent.

9.5.3 Write consistency

Under normal conditions, cyclic data is sampled and written at the Requested Packet Interval (RPI). However, if an option module was in the process of reading the mapped parameters while these parameters were being written, then the data obtained may not be consistent across the entire assembly object. If write consistency is enabled (*Out Consistency Enable* (**S.20.028**)) and a trigger parameter specified in *Out Consistency Trigger Param* (**S.20.029**) then new data will only be written to the drive (or option module) when the trigger parameter *Out Consistency Trigger Param* (**S.20.029**) contains a value of zero. This trigger parameter will then be set to one after the data has been written.

It is therefore possible, by controlling the trigger parameters, that a user program in the drive or option module can ensure that the values in the cyclic data parameters are not sampled until all values are updated.

Whether consistency is enabled or not, data will always be consistent for an individual parameter, i.e. all 4 bytes of a 32-bit value will be consistent.

Example

In this example, Pr **0.18.031** is set as the input trigger and Pr **0.18.032** is set as the output trigger. The EtherNet/IP master is configured to check the values of Pr **0.20.011** and Pr **0.20.012** are equal and write the same value to Pr **0.20.021**. The SI-Applications Plus module is configured to generate a ramp value between -32768 and 32767 to write to Pr **0.20.011** and Pr **0.20.012** when the value of Pr **0.20.021** is equal to the ramp value.

With the input and output consistency enabled, parameters Pr **0.20.011** and Pr **0.20.012** will be sampled and transmitted to the EtherNet/IP master when the input trigger parameter Pr **0.18.031** is a non-zero value, Pr **0.20.021** will be written to when the output trigger parameter Pr **0.18.032** is a value of zero.

The parameter changes required are:

S.20.020 <i>Input assembly object size</i>	= 8 (bytes)
S.20.021 <i>Output assembly object size</i>	= 4 (bytes)
S.20.026 <i>In Consistency Enable</i>	= On
S.20.027 <i>In Consistency Trigger Param</i>	= 0.18.031
S.20.028 <i>Out Consistency Enable</i>	= On
S.20.029 <i>Out Consistency Trigger Param</i>	= 0.18.032
S.21.001 <i>Input mapping parameter 1</i>	= 0.20.011
S.21.002 <i>Input mapping parameter 2</i>	= 0.20.012
S.22.001 <i>Output mapping parameter 1</i>	= 0.20.021

The user program in the SI-Applications Plus module may be written as follows (some changes may be necessary to account for bus cycle times and parameter update rates):

```
Initial{
    // Initialise variables
    NewValue% = 0
    #86.03 = 0 // Set digital output0 off
    #86.04 = 0 // Set digital output1 off
    #20.011 = 0 // Set input parameter 1 to 0
    #20.012 = 0 // Set input parameter 2 to 0
    #20.021 = 0 // Set output parameter 1 to 0
    REINIT // Initialise configuration
} //Initial

Background{
top:

IF #18.32 = 1 THEN
    // Output trigger set
    // Check first sum value against NewValue
    IF #20.021 = NewValue% THEN
        // OK increment values by 1
        NewValue% = NewValue% + 1
        IF NewValue% > 32767 THEN NewValue = -32768
        #20.011 = NewValue%
        #20.012 = NewValue%

        // Set input trigger – Read input parameters and
        // transmit to master
        #18.031 = 1

        // Delay for PLC to get inputs - depends on cycle
        // time and parameter access time
        DO WHILE #18.031 = 1
            // Dummy command
            NewValue% = NewValue%
        LOOP

        // Reset output trigger
        #18.032 = 0

        // Delay for outputs to be written - depends on
        // parameter access time
        DO WHILE #18.032 = 0
            // Dummy command
            NewValue% = NewValue%
        LOOP

    ELSE
        // ERROR - set DOP0 ON
        #86.03 = 1
    ENDIF
ENDIF

goto top: // main background loop
} //Background
```

Safety information	Product information	Mechanical installation	Electrical installation	Getting started	Basic parameters	Running the motor	Optimization	Drive communication	NV Media Card Operation	Onboard PLC	Advanced parameters	Diagnostics	UL information
--------------------	---------------------	-------------------------	-------------------------	-----------------	------------------	-------------------	--------------	---------------------	-------------------------	-------------	---------------------	-------------	----------------

9.5.4 Non-cyclic (explicit) data transfer

Non-cyclic or explicit messaging is used to read and write parameters non-cyclically by means of assembly objects. All of the AC Drives profile attributes can be accessed using explicit messaging.

The *Control Techniques* objects provide access to all drive and slot parameters using the following format.

Object	CT Group	CT This Slot	CT Slot 1	CT Slot 2	CT Slot 3	CT Slot 4
Class code	100 (0x64)	101 (0x65)	102 (0x66)	103 (0x67)	104 (0x68)	105 (0x69)
Instance	Menu					
Attribute	Parameter					
Read code	14 (0x0E) Get_Attribute_Single					
Write code	16 (0x10) Set_Attribute_Single					

NOTE An instance value of 0 is not a valid value in this context, therefore an instance value of 200 (0xC8) should be used to access menu 0 parameters. For more information on the *Control Techniques* object see section 9.5.21 *Control Techniques objects* on page 134.

9.5.5 Cyclic (implicit or polled) data transfer

Cyclic data is a method of data transfer that must be setup during network configuration, but is transmitted automatically at the determined rate once configuration is complete.

EtherNet/IP transfers cyclic data using assembly objects, "cyclic data" is sometimes referred to as "Polled data" or "implicit data".

The terms "input" and "output" refer to data from the perspective of the PLC, an "output" assembly object transfers data from the PLC to the drive, an "input" assembly object transfers data from the drive to the PLC.

NOTE Some PLCs provide the option of transmitting a configuration assembly object. The Ethernet interface does not use a configuration object; if one is required by the PLC then instance 1 should be specified with a length of 0 bytes.

9.5.6 Configuring EtherNet/IP cyclic parameters

In order to use cyclic data over EtherNet/IP, the EtherNet/IP interface must be configured to map the required parameter data to the assembly object.

For drive parameter access, object 100 (0x64) is used for reading parameters and object 101 (0x65) is used for writing parameters. The pre-defined assembly objects as listed in Table 9-17 *Supported drive assembly objects* can also be configured as cyclic data.

9.5.7 Assembly objects

An assembly object is an object which contains a group of attributes to control or monitor the drive operation. These attributes can be members of EtherNet/IP objects or drive parameters. The Ethernet interface supports a series of standard assembly objects and two *Control Techniques* objects (100 and 101) to access the drive parameters (see Table 9-17 *Supported drive assembly objects* on page 125).

NOTE Conformance with the pre-defined assembly objects specification can only be guaranteed if the speed reference configuration of the drive has not been changed from the default settings. For information on setting default values, refer to the appropriate drive user guide.

Table 9-17 Supported drive assembly objects

Assembly object name	Class		Length (Bytes)	Type	Default Mappings	
	Decimal	Hex (0x)			Bytes 0 to 3	Bytes 4 to 7
PrimaryI	100	64	4 to 80	Input	0.10.040	0.02.001
BscSpdCtrlI	70	46	4	Input		
ExtSpdCtrlI	71	47	4	Input		
SpdTrqCtrlI	72	48	6	Input		
ExtSpdTrqCtrlI	73	49	6	Input		
PrimaryO	101	65	4 to 80	Output	0.06.042	0.01.021
BscSpdCtrlO	20	14	4	Output		
ExtSpdCtrlO	21	15	4	Output		
SpdTrqCtrlO	22	16	6	Output		
ExtSpdTrqCtrlO	23	17	6	Output		

9.5.8 Basic speed control

Output assembly object 0x14 (20₁₀)

The PLC or scanner must be configured for 4 output bytes (or 2 output words) if this assembly object is to be used.

Table 9-18 Basic speed control

Data word	Function
Word 0	Basic control word.
Word 1	Speed reference (<i>SpeedRef</i>).

Basic control word

The basic control word consists of 2 bytes (16 bits), with only 2 bits of the low byte being used as shown below.

b15	b14	b13	b12	b11	b10	b9	b8
b7	b6	b5	b4	b3	b2	b1	b0
					FaultRst		RunFwd

The individual bit functions are described as follows:

Name	Control Word	Description
RunFwd	b0	Set this bit to command the drive to run in the forward direction.
FaultRst	b2	A 0 to 1 transition will reset the drive if the drive was in a trip state.

NOTE For the drive to run at the speed specified in Word 1, Pr 0.06.043 must be ON and bit 0, bit 7 and bit 8 of the drive control word (Pr 0.06.042) must all be set to 1 and the external hardware enable signal must be present.

Safety information	Product information	Mechanical installation	Electrical installation	Getting started	Basic parameters	Running the motor	Optimization	Drive communication	NV Media Card Operation	Onboard PLC	Advanced parameters	Diagnostics	UL information
--------------------	---------------------	-------------------------	-------------------------	-----------------	------------------	-------------------	--------------	----------------------------	-------------------------	-------------	---------------------	-------------	----------------

The individual bit functions for the drive control word are shown in Table 9-19 below.

Table 9-19 Drive control word bit functions

Bit	Function	Equivalent parameter
0	Drive enable	Pr 0.06.015
1	Run forward	Pr 0.06.030
2	Jog forward	Pr 0.06.031
3	Run reverse	Pr 0.06.032
4	Forward/reverse	Pr 0.06.033
5	Run	Pr 0.06.034
6	Not stop	Pr 0.06.039
7	Auto/manual	N/A
8	Analog/preset reference	Pr 0.01.042
9	Jog reverse	Pr 0.06.037
10	Reserved	N/A
11	Reserved	N/A
12	Trip drive	N/A
13	Reset drive	Pr 0.10.033
14	Keypad watchdog	N/A

Speed reference (SpeedRef)

The speed reference word utilises 2 bytes (16 bits) as shown below.

b15	b14	b13	b12	b11	b10	b9	b8
SpeedRef (high byte)							
b7	b6	b5	b4	b3	b2	b1	b0
SpeedRef (low byte)							

For more information on the setting of the speed reference see Table 9-40 AC/DC Drive object attributes on page 133.

9.5.9 Extended speed control

Output assembly object 0x15 (21₁₀)

The PLC or scanner must be configured for 4 output bytes (or 2 output words) if this assembly object is to be used.

Table 9-20 Extended speed control

Data word	Function
Word 0	Extended control word.
Word 1	Speed reference (<i>SpeedRef</i>).

Extended control word

The extended control word consists of 2 bytes (16 bits), with only the low byte used as shown.

b15	b14	b13	b12	b11	b10	b9	b8
b7	b6	b5	b4	b3	b2	b1	b0
	NetRef	NetCtrl			FaultRst	RunRev	RunFwd

The individual bit functions are described as follows:

Name	Control Word	Description
RunFwd	b0	Set this bit to command the drive to run in the forward direction.
RunRev	b1	Set this bit to command the drive to run in the reverse direction.
FaultRst	b2	A 0 to 1 transition will reset the drive if the drive was in a trip state.
NetCtrl	b5	Used in conjunction with Pr 0.06.043 to enable the drive control word bits b0-b6 and bit 9 (Pr 0.06.042).
NetRef	b6	Set this bit to command the drive to use the remote speed reference value specified in Word 1.

NOTE For the drive to run at the speed specified in Word 1, Pr **0.06.043** must be ON and bit 0, bit 7 and bit 8 of the drive control word (Pr **0.06.042**) must all be set to 1 and the external hardware enable signal must be present.

NOTE For information on the drive control word see Table 9-19 *Drive control word bit functions* on page 126.

NOTE Conformance with the pre-defined assembly objects specification can only be guaranteed if the speed reference configuration of the drive has not been changed from the default settings. For information on setting default values, refer to the appropriate drive user guide.

Speed reference (SpeedRef)

The speed reference word utilises 2 bytes (16 bits) as shown below.

b15	b14	b13	b12	b11	b10	b9	b8
SpeedRef (high byte)							
b7	b6	b5	b4	b3	b2	b1	b0
SpeedRef (low byte)							

For more information on the setting of the speed reference see Table 9-40 AC/DC Drive object attributes on page 133.

9.5.10 Basic speed and torque control

Output assembly object 0x16 (22₁₀)

The PLC or scanner must be configured for 6 output bytes (or 3 output words) if this assembly object is to be used.

Table 9-21 Basic speed and torque control

Data Word	Function
Word 0	Basic control word.
Word 1	Speed reference (<i>SpeedRef</i>).
Word 2	Torque reference (<i>TorqueRef</i>).

Basic control word

The basic control word consists of 2 bytes (16 bits), with only 2 bits of the low byte being used as shown below.

b15	b14	b13	b12	b11	b10	b9	b8
b7	b6	b5	b4	b3	b2	b1	b0
					FaultRst		RunFwd

The individual bit functions are described as follows:

Name	Control Word	Description
RunFwd	b0	Set this bit to command the drive to run in the forward direction.
FaultRst	b2	A 0 to 1 transition will reset the drive if the drive was in a trip state.

NOTE For the drive to run at the speed specified in Word 1, Pr **0.06.043** must be ON and bit 0, bit 7 and bit 8 of the drive control word (Pr**0.06.043**) must all be set to 1.

Safety information	Product information	Mechanical installation	Electrical installation	Getting started	Basic parameters	Running the motor	Optimization	Drive communication	NV Media Card Operation	Onboard PLC	Advanced parameters	Diagnostics	UL information
--------------------	---------------------	-------------------------	-------------------------	-----------------	------------------	-------------------	--------------	---------------------	-------------------------	-------------	---------------------	-------------	----------------

NOTE For information on the drive control word see Table 9-19 *Drive control word bit functions* on page 126.

Speed reference (SpeedRef)

The speed reference word utilises 2 bytes (16 bits) as shown below.

b15	b14	b13	b12	b11	b10	b9	b8
SpeedRef (high byte)							
b7	b6	b5	b4	b3	b2	b1	b0
SpeedRef (low byte)							

For more information on the setting of the speed reference see Table 9-40 *AC/DC Drive object attributes* on page 133.

Torque reference (TorqueRef)

The torque reference word utilises 2 bytes (16 bits) as shown below.

b15	b14	b13	b12	b11	b10	b9	b8
TorqueRef (high byte)							
b7	b6	b5	b4	b3	b2	b1	b0
TorqueRef (low byte)							

For more information on the setting of the torque reference see Table 9-40 *AC/DC Drive object attributes* on page 133.

9.5.11 Extended speed and torque control

Output assembly object 0x17 (23₁₀)

The PLC or scanner must be configured for 6 output bytes (or 3 output words) if this assembly object is to be used.

Table 9-22 Extended speed and torque control

Data word	Function
Word 0	Extended control word.
Word 1	Speed reference (<i>SpeedRef</i>).
Word 2	Torque reference (<i>TorqueRef</i>).

Extended control word

The extended control word consists of 2 bytes (16 bits), with only 5 bits of the low byte used as shown below.

b15	b14	b13	b12	b11	b10	b9	b8
b7	b6	b5	b4	b3	b2	b1	b0
	NetRef	NetCtrl			FaultRst	RunRev	RunFwd

The individual bit functions are described as follows:

Name	Control Word	Description
RunFwd	b0	Set this bit to command the drive to run in the forward direction.
RunRev	b1	Set this bit to command the drive to run in the reverse direction.
FaultRst	b2	A 0 to 1 transition will reset the drive if the drive was in a trip state.
NetCtrl	b5	Used in conjunction with Pr 06.043 to enable the drive control word bits b0-b6 and bit 9 (Pr 06.042).
NetRef	b6	Set this bit to command the drive to use the remote speed reference value specified in Word 1.

NOTE For the drive to run at the speed specified in Word 1, Pr **06.043** must be ON and bit 0, bit 7 and bit 8 of the drive control word (Pr **06.042**) must all be set to 1 and the external hardware enable signal must be present.

NOTE For information on the drive control word see Table 9-19 *Drive control word bit functions* on page 126.

Speed reference (SpeedRef)

The speed reference word utilises 2 bytes (16 bits) as shown below.

b15	b14	b13	b12	b11	b10	b9	b8
SpeedRef (high byte)							
b7	b6	b5	b4	b3	b2	b1	b0
SpeedRef (low byte)							

For more information on the setting of the speed reference see Table 9-40 *AC/DC Drive object attributes* on page 133.

Torque reference (TorqueRef)

The torque reference word utilises 2 bytes (16 bits) as shown below.

b15	b14	b13	b12	b11	b10	b9	b8
TorqueRef (high byte)							
b7	b6	b5	b4	b3	b2	b1	b0
TorqueRef (low byte)							

For more information on the setting of the torque reference see Table 9-40 *AC/DC Drive object attributes* on page 133.

9.5.12 Basic speed feedback

Input assembly object 0x46 (70₁₀)

The PLC or scanner must be configured for 4 input bytes (or 2 input words) if this assembly object is to be used.

Table 9-23 Basic speed feedback

Data word	Function
Word 0	Basic status word.
Word 1	Speed feedback (<i>SpeedActual</i>).

Basic status word

The basic status word consists of 2 bytes (16 bits), with only 2 bits of the low byte used as shown below.

b15	b14	b13	b12	b11	b10	b9	b8
b7	b6	b5	b4	b3	b2	b1	b0
					Running 1 (Fwd)		Faulted

The individual bit functions are described as follows:

Bit	Name	Description
b0	Faulted	Indicates whether the drive is OK or tripped (0=OK, 1=Tripped).
b2	Running1 (Fwd)	Indicates if the drive is running in the forward direction (0=False, 1=True).

Speed feedback (SpeedActual)

The speed feedback word utilises 2 bytes (16 bits) as shown below.

b15	b14	b13	b12	b11	b10	b9	b8
SpeedActual (high byte)							
b7	b6	b5	b4	b3	b2	b1	b0
SpeedActual (low byte)							

For more information on the speed feedback see Table 9-40 *AC/DC Drive object attributes* on page 133.

Safety information	Product information	Mechanical installation	Electrical installation	Getting started	Basic parameters	Running the motor	Optimization	Drive communication	NV Media Card Operation	Onboard PLC	Advanced parameters	Diagnostics	UL information
--------------------	---------------------	-------------------------	-------------------------	-----------------	------------------	-------------------	--------------	---------------------	-------------------------	-------------	---------------------	-------------	----------------

9.5.13 Extended speed feedback

Input assembly object 0x47 (71₁₀)

The PLC or scanner must be configured for 4 input bytes (or 2 input words) if this assembly object is to be used.

Table 9-24 Extended speed feedback

Data word	Function
Word 0	Extended status word.
Word 1	Speed feedback (<i>SpeedActual</i>).

Extended status word

The extended status word consists of 2 bytes (16 bits), with the bits having functions as shown below.

b15	b14	b13	b12	b11	b10	b9	b8
DriveState							
b7	b6	b5	b4	b3	b2	b1	b0
At Reference	RefFrom Net	CtrlFrom Net	Ready	Running2 (Rev)	Running1 (Fwd)	Warning	Faulted

The DriveState byte returns a code to indicate the operating state of the drive as shown in Table 9-25 following.

Table 9-25 DriveState codes

Code	b15 - b8	State	Description
1	00000001	Startup	This state is skipped over on CT drives.
2	00000010	Not_Ready	Inhibit.
3	00000011	Ready	Ready.
4	00000100	Enabled	Run or Stop.
5	00000101	Stopping	Deceleration or Injection.
6	00000110	Fault_Stop	AC_UU (this will only occur if Mains Loss is enabled).
7	00000111	Faulted	Tripped.
0	00000000	Vendor Specific	All other DriveType states, e.g. Scan, Orienting, Regen Active, etc.

The individual bits of the low byte of the extended status word are described below.

Extended status word (low byte)

Name	Bit	Description
Faulted	b0	Indicates whether the drive is OK or tripped. 0=OK (Pr 0.10.001=1). 1=Tripped (Pr 0.10.001=0).
Warning	b1	Indicates if one of the drive alarms is active.
Running1 (Fwd)	b2	Indicates if the drive is running in the forward direction. 0=False, 1=True.
Running2 (Rev)	b3	Indicates if the drive is running in the reverse direction. 0=False, 1=True.
Ready	b4	The 'Ready' bit is set depending on which state the drive is in. Ready = True. Enabled = True. Stopping = True. All others = False.
CtrlFromNet	b5	Indicates if the drive is being controlled from the 'Drive Control Word'. 0=False, 1=True.
RefFromNet	b6	Indicates if the speed reference is derived from Pr 0.01.021. 0=False (Pr 0.01.050<>1 OR Pr 0.01.049<>3). 1=True (Pr 0.01.050=1 AND Pr 0.01.049=3).
AtReference	b7	Indicates if the drive speed has reached the set reference. 0=False (Pr 0.10.006=0). 1=True (Pr 0.10.006=1).

Speed feedback (*SpeedActual*)

The speed feedback word utilises 2 bytes (16 bits) as shown below.

b15	b14	b13	b12	b11	b10	b9	b8
SpeedActual (high byte)							
b7	b6	b5	b4	b3	b2	b1	b0
SpeedActual (low byte)							

For more information on the speed feedback see Table 9-40 AC/DC Drive object attributes on page 133.

9.5.14 Basic speed and torque feedback

Input assembly object 0x48 (72₁₀)

The PLC or scanner must be configured for 6 input bytes (or 3 input words) if this assembly object is to be used.

Table 9-26 Basic speed and torque feedback

Data word	Function
Word 0	Basic status word.
Word 1	Speed feedback (<i>SpeedActual</i>).
Word 2	Torque feedback (<i>TorqueActual</i>).

Basic status word

The basic status word consists of 2 bytes (16 bits), with only the low byte used as shown below.

b15	b14	b13	b12	b11	b10	b9	b8
b7	b6	b5	b4	b3	b2	b1	b0
					Running1 (Fwd)	Faulted	

The individual bit functions are described as follows:

Bit	Name	Description
b0	Faulted	Indicates whether the drive is OK or tripped (0=OK, 1=Tripped).
b2	Running1 (Fwd)	Indicates if the drive is running in the forward direction (0=False, 1=True).

Speed feedback (*SpeedActual*)

The speed feedback word utilises 2 bytes (16 bits) as shown below.

b15	b14	b13	b12	b11	b10	b9	b8
SpeedActual (high byte)							
b7	b6	b5	b4	b3	b2	b1	b0
SpeedActual (low byte)							

For more information on the speed feedback see Table 9-40 AC/DC Drive object attributes on page 133.

Torque feedback (*TorqueActual*)

The torque feedback word utilises 2 bytes (16 bits) as shown below.

b15	b14	b13	b12	b11	b10	b9	b8
TorqueActual (high byte)							
b7	b6	b5	b4	b3	b2	b1	b0
TorqueActual (low byte)							

For more information on the torque feedback see Table 9-40 AC/DC Drive object attributes on page 133.

Safety information	Product information	Mechanical installation	Electrical installation	Getting started	Basic parameters	Running the motor	Optimization	Drive communication	NV Media Card Operation	Onboard PLC	Advanced parameters	Diagnostics	UL information
--------------------	---------------------	-------------------------	-------------------------	-----------------	------------------	-------------------	--------------	---------------------	-------------------------	-------------	---------------------	-------------	----------------

9.5.15 Extended speed and torque feedback

Input assembly object 0x49 (73₁₀)

The PLC or scanner must be configured for 6 input bytes (or 3 input words) if this assembly object is to be used.

Table 9-27 Basic speed and torque feedback

Data word	Function
Word 0	Extended status word.
Word 1	Speed feedback (<i>SpeedActual</i>).
Word 2	Torque feedback (<i>TorqueActual</i>).

Extended status word

The extended status word consists of 2 bytes (16 bits), with the bits having functions as shown below.

b15	b14	b13	b12	b11	b10	b9	b8
DriveState							
b7	b6	b5	b4	b3	b2	b1	b0
At Reference	RefFrom Net	CtrlFrom Net	Ready	Running2 (Rev)	Running1 (Fwd)	Warning	Faulted

The DriveState byte returns a code to indicate the operating state of the drive as shown in Table 9-28.

Table 9-28 DriveState codes

Code	b15 - b8	State	Description
1	00000001	Startup	This state is skipped over on CT drives.
2	00000010	Not_Ready	Inhibit.
3	00000011	Ready	Ready.
4	00000100	Enabled	Run or Stop.
5	00000101	Stopping	Deceleration or Injection.
6	00000110	Fault_Stop	AC_UU (this will only occur if Mains Loss is enabled).
7	00000111	Faulted	Tripped.
0	00000000	Vendor Specific	All other DriveType states, e.g. Scan, Orienting, Regen Active, etc.

The individual bits of the low byte of the extended status word are described in Table 9-29 *Extended status word (low byte)* on page 129.

Table 9-29 Extended status word (low byte)

Name	Bit	Description
Faulted	b0	Indicates whether the drive is OK or tripped. 0=OK (Pr 0.10.001=1). 1=Tripped (Pr 0.10.001=0).
Warning	b1	Indicates if one of the drive alarms is active.
Running1 (Fwd)	b2	Indicates if the drive is running in the forward direction. 0=False, 1=True.
Running2 (Rev)	b3	Indicates if the drive is running in the reverse direction. 0=False, 1=True.
Ready	b4	The 'Ready' bit is set depending on which state the drive is in. Ready = True. Enabled = True. Stopping = True. All others = False.
CtrlFromNet	b5	Indicates if the drive is being controlled from the 'Drive Control Word'. 0=False, 1=True.
RefFromNet	b6	Indicates if the speed reference is derived from Pr 0.01.021. 0=False (Pr 0.01.050<>1 OR Pr 0.01.049<>3). 1=True (Pr 0.01.050=1 AND Pr 0.01.049=3).
AtReference	b7	Indicates if the drive speed has reached the set reference. 0=False (Pr 0.10.006=0). 1=True (Pr 0.10.006=1).

Speed feedback (*SpeedActual*)

The speed feedback word utilises 2 bytes (16 bits) as shown below.

b15	b14	b13	b12	b11	b10	b9	b8
SpeedActual(high byte)							
b7	b6	b5	b4	b3	b2	b1	b0
SpeedActual (low byte)							

For more information on the speed feedback see Table 9-40 *AC/DC Drive object attributes* on page 133.

Torque feedback (*TorqueActual*)

The torque feedback word utilises 2 bytes (16 bits) as shown below.

b15	b14	b13	b12	b11	b10	b9	b8
TorqueActual (high byte)							
b7	b6	b5	b4	b3	b2	b1	b0
TorqueActual (low byte)							

For more information on the torque feedback see Table 9-40 *AC/DC Drive object attributes* on page 133.

9.5.16 Object Model

The Object Model has the following object classes present.

Table 9-30 Supported Objects

Object Class	Class Code		Number of Instances	Effect
	Decimal	Hex (0x)		
Identity	1	01	1	Provides device specific information.
Assembly	4	04	16	Defines the I/O data format (parameter mapping).
Motor Data	40	28	2	Defines the motor data.
Control Supervisor	41	29	1	Provides drive control and monitoring information.
AC/DC Drive	42	2A	1	Provides drive configuration and running state information.
CT Group	100	64	<No. of menus>	Provides access to drive parameters.
CT This Slot	101	65	<No. of menus>	Provides access to the local option module parameters.
CT Slot 1	102	66	<No. of menus>	Provides access to the option module parameters in slot 1.
CT Slot 2	103	67	<No. of menus>	Provides access to the option module parameters in slot 2.
CT Slot 3	104	68	<No. of menus>	Provides access to the option module parameters in slot 3.
CT Slot 4	105	69	<No. of menus>	Provides access to the onboard Ethernet interface parameters.

9.5.17 Identity object

Class: 0x01 (1₁₀)

The identity object provides identification of and general information about the device.

Table 9-31 Identity object

Attribute	Access	Name	Data Type
1	Get	VendorID	UINT
2	Get	DeviceType	UINT
3	Get	ProductCode	UINT
4	Get	Revision	USINT
6	Get	SerialNumber	UDINT
7	Get	ProductName	SHORT_STRING

Safety information	Product information	Mechanical installation	Electrical installation	Getting started	Basic parameters	Running the motor	Optimization	Drive communication	NV Media Card Operation	Onboard PLC	Advanced parameters	Diagnostics	UL information
--------------------	---------------------	-------------------------	-------------------------	-----------------	------------------	-------------------	--------------	---------------------	-------------------------	-------------	---------------------	-------------	----------------

Vendor ID

Name:	VendorID		
Class	0x01	Default	0x101 (257 ₁₀)
Instance	0x01	Data Type	UINT
Attribute	0x01	Access	Get

Returns the vendor ID code 0x101 (257₁₀) for *Control Techniques*.

Device type

Name:	DeviceType		
Class	0x01	Default	0x02
Instance	0x01	Data Type	UINT
Attribute	0x02	Access	Get

Returns the device type code. The following codes are used:

Device Type code	Drive type
0x02	AC Drive

Product code

Name:	Product Code		
Class	0x01	Default	See below
Instance	0x01	Data Type	UINT
Attribute	0x03	Access	Get

Returns a 16 bit value to identify the drive type and drive mode and also links a node to the installed EDS files. The product code is calculated as shown in Table 9-32 *Product code bit allocation* below.

Table 9-32 Product code bit allocation

b15	b14	b13	b12	b11	b10	b9	b8	b7	b6	b5	b4	b3	b2	b1	b0
Drive Type				Drive Derivative				Drive Mode				CIP code			

Drive Type (b15 to b11)

The drive type is defined as follows:

Value	Drive Type
2	Unidrive M

Drive Derivative (b10 to b6)

The drive derivative as shown in Pr **0.11.028**.

For more information on the drive derivative codes please refer to the relevant drive documentation.

Drive Mode (b5 to b3)

The drive operating mode is defined as follows:

Value	Operating Mode
0	Open-loop
1	RFC-A
2	RFC-S
3	Regen

CIP code (b2 to b0)

The CIP (Common Industrial Protocol) interface code is defined as follows:

Value	Interface ID	Description
0	430	Unidrive M700 onboard Ethernet
1	447	SI-DeviceNet
2	310	MCI210
3	433	SI-Ethernet

Revision

Name:	Revision		
Class	0x01	Default	N/A
Instance	0x01	Data Type	ARRAY of USINT
Attribute	0x04	Access	Get

Returns 2 bytes to indicate the major and minor revision numbers of the Ethernet interface firmware version.

The Ethernet interface firmware version (**MM.002**) consists of four 2-digit decimal numbers with the following significance:

[Major].[Minor].[Bugfix].[Build].

The revision code returns the major and minor revisions of the Ethernet interface firmware version in two unsigned bytes, the major revision being returned first followed by the minor revision.

Table 9-33 Revision specification

b7	b6	b5	b4	b3	b2	b1	b0
Major revision (MM.002 / 1000000)							
R	Minor revision (MM.002 / 10000) Mod 100						

Where "Mod 100" refers to the fractional value of the result from **MM.002**/10000, (the value after the decimal point).

e.g. For a value of 12345678 in Pr **MM.002** (12.34.56.78 on the keypad display), the major revision is 12 and the minor revision is 34.

The returned data will consist of 2 unsigned bytes, the first byte will be the major revision value 12 (0x0C) and the second byte will be the minor revision value 34 (0x22).

Major revision

b7	b6	b5	b4	b3	b2	b1	b0
0	0	0	0	1	1	0	0
Major revision = 12 (0x0C)							

Minor revision

b6	b5	b4	b3	b2	b1	b0
0	1	0	0	0	1	0
Minor revision = 34 (0x22)						

Serial Number

Name:	SerialNumber		
Class	0x01	Default	N/A
Instance	0x01	Data Type	UDINT
Attribute	0x06	Access	Get

Returns the lower 4 bytes (32 bits) of the Ethernet interface serial number.

The Ethernet interface serial number is contained within two adjacent parameters, Pr **MM.004 Serial Number LS** displays the least 8 significant decimal digits and Pr **MM.005 Serial Number MS** displays the most 8 significant decimal digits.

For example, if the serial number of the onboard Ethernet interface is 123456789 then Pr **MM.005 Serial Number MS** will display 1 and Pr **MM.004 Serial Number LS** will display 23456789.

The Ethernet interface serial number is set during manufacture and cannot be changed.

Product Name

Name:	ProductName		
Class	0x01	Default	Onboard Ethernet Factory Fitted Ethernet SI-Ethernet
Instance	0x01	Data Type	SHORT_STRING
Attribute	0x07	Access	Get

Returns the product name as a short string of ASCII Bytes. The first byte specifies the number of following bytes that constitute the product name.

9.5.18 Motor data object

Class: 0x28 (40₁₀)

There are 2 instances of the Motor data object. Instance 1 will represent menu 5 motor information (motor 1) and instance 2 will represent menu 21 motor information (motor 2). The instance being used by the other dependant objects will be determined by Pr **0.11.045**, to use the second motor map objects (instance 2), Pr **0.11.045** should be set to *Motor 2*. Pr **0.11.045** is polled in the background task, so the user should be

Safety information	Product information	Mechanical installation	Electrical installation	Getting started	Basic parameters	Running the motor	Optimization	Drive communication	NV Media Card Operation	Onboard PLC	Advanced parameters	Diagnostics	UL information
--------------------	---------------------	-------------------------	-------------------------	-----------------	------------------	-------------------	--------------	---------------------	-------------------------	-------------	---------------------	-------------	----------------

aware that during motor map changeover, the RPM speed reference may not be accurate. The available attributes and associated functions for the AC motor data object are shown in Table 9-34 AC Motor data object attributes below.

Table 9-34 AC Motor data object attributes

AC Motor Instance Attributes			Drive Parameter	
Attribute ID	Name	Access	Instance 1	Instance 2
0x03 (3 ₁₀)	MotorType (*)	Get/Set	None	None
0x06 (6 ₁₀)	RatedCurrent	Get/Set	Pr 0.05.007 (scaled to 100 mA units)	Pr 0.21.007 (scaled to 100 mA units)
0x07 (7 ₁₀)	RatedVoltage	Get/Set	Pr 0.05.009	Pr 0.21.009
0x09 (9 ₁₀)	RatedFreq	Get/Set	Pr 0.05.006 (scaled to Hz)	Pr 0.21.006 (scaled to Hz)
0x0F (15 ₁₀)	BaseSpeed	Get/Set	Pr 0.05.008 (scaled to rpm units)	Pr 0.21.008 (scaled to rpm units)
0x64 (100 ₁₀)	Motor2Select	Get	Pr 0.21.015	Pr 0.21.015
		Set	Pr 0.11.045	Pr 0.11.045

(* The MotorType attribute has no effect on drive operation, it is only used to provide information to the user as shown in Table 9-35 Supported motor types below).

Table 9-35 Supported motor types

Value	Motor Type
6	Wound rotor induction motor
7	Squirrel cage induction motor (default)
9	Sinusoidal PM BL motor
10	Trapezoidal PM BL motor

NOTE In Open loop mode, only values 6 and 7 will be supported.

Motor type

Name:	MotorType1		
Class	0x28	Default	7
Instance	0x01	Data Type	USINT
Attribute	0x03	Access	Get/Set

Returns or sets the motor type to be used by the drive for instance 1.

Name:	MotorType2		
Class	0x28	Default	7
Instance	0x02	Data Type	USINT
Attribute	0x03	Access	Get/Set

Returns or sets the motor type to be used by the drive for instance 2.

Rated current

Name:	RatedCurrent1		
Class	0x28	Default	Pr 0.05.007 / 10
Instance	0x01	Data Type	USINT
Attribute	0x06	Access	Get/Set

Returns or sets the rated motor current in Amps for instance 1. This attribute is linked to Pr 0.05.007.

Set Pr 0.05.007 = RatedCurrent1 * 10.
Get RatedCurrent1 = Pr 0.05.007 / 10.

Name:	RatedCurrent2		
Class	0x28	Default	Pr 0.21.007 / 10
Instance	0x02	Data Type	USINT
Attribute	0x06	Access	Get/Set

Returns or sets the rated motor current in Amps for instance 2. This attribute is linked to Pr 0.21.007.

Set Pr 0.21.007 = RatedCurrent2 * 10.

Get RatedCurrent2 = Pr 0.21.007 / 10.

Rated voltage

Name:	RatedVoltage1		
Class	0x28	Default	Pr 0.05.009
Instance	0x01	Data Type	USINT
Attribute	0x07	Access	Get/Set

Returns or sets the rated motor voltage in Volts for instance 1. This attribute is linked to Pr 0.05.009.

Name:	RatedVoltage2		
Class	0x28	Default	Pr 0.21.009
Instance	0x02	Data Type	USINT
Attribute	0x07	Access	Get/Set

Returns or sets the rated motor voltage in Volts for instance 2. This attribute is linked to Pr 0.21.009.

Rated frequency

Name:	RatedFreq1		
Class	0x28	Default	Pr 0.05.006 / 10
Instance	0x01	Data Type	USINT
Attribute	0x09	Access	Get/Set

Returns or sets the rated motor frequency in Hertz for instance 1. This attribute is linked to Pr 0.05.006.

Set Pr 0.05.006 = RatedFreq1 * 10.
Get RatedFreq1 = Pr 0.05.006 / 10.

Name:	RatedFreq2		
Class	0x28	Default	Pr 0.21.006 / 10
Instance	0x02	Data Type	USINT
Attribute	0x09	Access	Get/Set

Returns or sets the rated motor frequency in Hertz for instance 2. This attribute is linked to Pr 21.006.

Set Pr 0.21.006 = RatedFreq2 * 10.
Get RatedFreq2 = Pr 0.21.006 / 10.

Base speed

Name:	BaseSpeed1		
Class	0x28	Default	Pr 0.05.008
Instance	0x01	Data Type	USINT
Attribute	0x0F	Access	Get/Set

Returns or sets the base speed of the motor in RPM for instance 1. This attribute is linked to Pr 0.05.008.

Name:	BaseSpeed2		
Class	0x28	Default	Pr 0.21.008
Instance	0x02	Data Type	USINT
Attribute	0x0F	Access	Get/Set

Returns or sets the base speed of the motor in RPM for instance 2. This attribute is linked to Pr 0.21.008.

Motor2Select

Name:	Motor2Select		
Class	0x28	Default	
Instance	0x01	Data Type	USINT
Attribute	0x64	Access	Get/Set

Selects between Motor 1 and Motor 2. This attribute is linked to Pr 0.11.045. When this bit is set to 1, Motor 2 will be active.

NOTE Any change in this attribute will be implemented when the drive is disabled.

Safety information	Product information	Mechanical installation	Electrical installation	Getting started	Basic parameters	Running the motor	Optimization	Drive communication	NV Media Card Operation	Onboard PLC	Advanced parameters	Diagnostics	UL information
--------------------	---------------------	-------------------------	-------------------------	-----------------	------------------	-------------------	--------------	---------------------	-------------------------	-------------	---------------------	-------------	----------------

9.5.19 Control Supervisor object

Class: 0x29 (41₁₀)

The Control Supervisor object provides access to various attributes which control or monitor the drive running state. The available attributes and their associated functions are shown in Table 9-36 following.

Table 9-36 Control Supervisor object attribute

Attribute ID		Access	Name	Parameter dependence
Decimal	Hex (0x)			
3	03	Get/Set	RunFwd	0.06.042 bit1
4	04	Get/Set	RunRev	0.06.042 bit3
5	05	Get/Set	NetCtrl	0.06.042 bit7
6	06	Get	State	See Table 9-37 Control Supervisor state attributes on page 132
7	07	Get	RunningFwd	1 (0.10.040 AND 0x2002) = 0x0002 0 (0.10.040 AND 0x2002) <> 0x0002
8	08	Get	RunningRev	1 (0.10.040 AND 0x2002) = 0x2002 0 (0.10.040 AND 0x2002) <> 0x2002
9	09	Get	Ready	See Table 9-37 Control Supervisor state attributes on page 132
10	0A	Get	Faulted	Inverse of 0.10.001
11	0B	Get	Warning	0.10.019
12	0C	Get/Set	FaultRst	Sets 0.10.038 to 100 on a 0 to 1 transition
13	0D	Get	FaultCode	See Table 9-37 Control Supervisor state attributes on page 132
15	0F	Get	CtrlFromNet	0.06.042 bit7 AND 0.06.043
102	66	Get/Set	DriveEnable	0.06.042 bit0

RunFwd

Name:	RunFwd		
Class	0x29	Default	N/A
Instance	0x01	Data Type	USINT
Attribute	0x03	Access	Get/Set

Set to 1 to run the drive in the forward direction.

Get/Set Pr 0.06.042 (bit 1).

RunRev

Name:	RunRev		
Class	0x29	Default	N/A
Instance	0x01	Data Type	USINT
Attribute	0x04	Access	Get/Set

Set to 1 to run the drive in the reverse direction.

Get/Set Pr 0.06.042 (bit 3).

NetCtrl

Name:	NetCtrl		
Class	0x29	Default	N/A
Instance	0x01	Data Type	USINT
Attribute	0x05	Access	Get/Set

Switches between terminal and fieldbus control.

Get/Set Pr 0.06.042 (bit 7)

0 = Terminal control.

1 = Fieldbus control.

State

Name:	State		
Class	0x29	Default	N/A
Instance	0x01	Data Type	USINT
Attribute	0x06	Access	Get

This returns a code to indicate the current running state of the drive as shown in Table 9-37 following.

Table 9-37 Control Supervisor state attributes

Code	State	Parameter Dependence	Description
1	Startup	N/A	This state is skipped over
2	Not_Ready	0.10.101 = 0	Inhibit
3	Ready	0.10.101 = 1	Ready
4	Enabled	0.10.101 = 2 OR 0.10.101 = 4	Stop or Run
5	Stopping	0.10.101 = 6 OR 0.10.101 = 7	Decelerating or DC injection braking
6	Fault_Stop	0.10.101 = 5	AC supply loss
7	Faulted	0.10.101 = 9	Tripped
0	Vendor Specific	0.10.101 = All other drive states	See parameter reference guide

RunningFwd

Name:	RunningFwd		
Class	0x29	Default	N/A
Instance	0x01	Data Type	USINT
Attribute	0x07	Access	Get

Indicates that the drive is running in the forward direction.

This attribute will be set to 1 when Pr 0.10.014 = 0 and Pr 0.10.002 = 1.

RunningRev

Name:	RunningRev		
Class	0x29	Default	N/A
Instance	0x01	Data Type	USINT
Attribute	0x08	Access	Get

Indicates that the drive is running in the reverse direction.

This attribute will be set to 1 when Pr 0.10.014 = 0 and Pr 0.10.002 = 1.

Ready

Name:	Ready		
Class	0x29	Default	N/A
Instance	0x01	Data Type	USINT
Attribute	0x09	Access	Get

The Ready attribute will be set in accordance with the state as shown in Table 9-38.

Table 9-38 Control Supervisor Ready attributes

Code	State	Ready state
3	Ready	True
4	Enabled	True
5	Stopping	True
All others		False

Faulted

Name:	Faulted		
Class	0x29	Default	N/A
Instance	0x01	Data Type	USINT
Attribute	0x0A	Access	Get

Indicates that the drive is tripped, i.e. not OK (inverse of Pr 0.10.001).

Get 1 = Pr 0.10.001 = 0.

Get 0 = Pr 0.10.001 = 1.

Safety information	Product information	Mechanical installation	Electrical installation	Getting started	Basic parameters	Running the motor	Optimization	Drive communication	NV Media Card Operation	Onboard PLC	Advanced parameters	Diagnostics	UL information
--------------------	---------------------	-------------------------	-------------------------	-----------------	------------------	-------------------	--------------	---------------------	-------------------------	-------------	---------------------	-------------	----------------

Warning

Name:	Warning		
Class	0x29	Default	N/A
Instance	0x01	Data Type	USINT
Attribute	0x0B	Access	Get

Indicates that one of the drive alarms is active.

Get Pr **0.10.019**.

FaultRst

Name:	FaultRst		
Class	0x29	Default	N/A
Instance	0x01	Data Type	USINT
Attribute	0x0C	Access	Get/Set

Resets the drive from a tripped condition.

Sets Pr **0.10.038** to 100 on a 0 to 1 transition.

FaultCode

Name:	FaultCode		
Class	0x29	Default	N/A
Instance	0x01	Data Type	USINT
Attribute	0x0D	Access	Get

The fault code attribute will return the ODVA fault code as follows:

If the drive is not OK, the drive fault code is obtained from Pr **0.10.020**, if the drive fault code is listed in Table 9-39, then the ODVA fault code as shown in Table 9-39 below will be returned.

If the drive fault code is not listed in Table 9-39 then the Ethernet interface will return the ODVA code as follows:

ODVA Fault Code = 0x1000 + drive fault code.

Table 9-39 Control Supervisor fault code attributes

Drive Fault Code	ODVA Fault Code	Drive Fault Code	ODVA Fault Code
1	0x3220	20	0x2310
2	0x3210	21	0x4300
3	0x2300	26	0x5112
4	0x7112	32	0x3130
6	0x9000		

CtrlFromNet

Name:	CtrlFromNet		
Class	0x29	Default	N/A
Instance	0x01	Data Type	USINT
Attribute	0x0F	Access	Get

Indicates whether the drive is operating under fieldbus or terminal control.

This attribute will be set to 1 if Pr **0.06.042** (bit 7) = 1 and Pr **0.06.043** = 1 (fieldbus).

DriveEnable

Name:	DriveEnable		
Class	0x29	Default	N/A
Instance	0x01	Data Type	USINT
Attribute	0x66	Access	Get/Set

Enables the drive. This puts the drive into the "Ready" state, allowing the **RunFwd** and **RunRev** attributes to control the drive. **RunFwd** and **RunRev** will have no effect if **DriveEnable** is not set to 1.

Get/Set Pr **0.06.042** bit 0.

NOTE The external hardware enable signal must also be present before the drive will enter the Ready state.

9.5.20 AC/DC Drive object

Class: 0x2A (42₁₀)

The AC/DC Drive object provides information on the drive running state and supports the following attributes:

Table 9-40 AC/DC Drive object attributes

Attribute ID	Name	Access	Parameter dependence
0x03 (3 ₁₀)	AtReference	Get	Pr 0.10.006
0x04 (4 ₁₀)	NetRef	Get/Set	Pr 0.06.042 (bit 8)
0x06 (6 ₁₀)	DriveMode	Get/Set	(See Table 9-41 on page 134)
0x07 (7 ₁₀)	SpeedActual	Get	RFC-A or RFC-S Pr 0.03.002
			Open Loop Pr 0.05.004
0x08 (8 ₁₀)	SpeedRef	Get/Set	RFC-A or RFC-S Pr 0.01.021 (scaled to 0 decimal places)
		Get	Open Loop Pr 0.01.021 * 60 / <i>NofPP</i> (scaled to 0 decimal places)
		Set	Open Loop Pr 0.01.021 = SpeedRef * <i>NofPP</i> / 60 (scaled to 0 decimal places)
0x0B (11 ₁₀)	TorqueActual	Get	Pr 0.04.020 (scaled to 1 decimal place)
0x0C (12 ₁₀)	TorqueRef	Get/Set	Pr 0.04.008 (scaled to 1 decimal place)
0x1D (29 ₁₀)	RefFromNet	Get	1 Pr 0.01.049 =3 AND Pr 0.01.050 =1
			0 Pr 0.01.049 <>3 OR Pr 0.01.050 <>1

NOTE *NofPP* = Number of Pole Pairs.

AtReference

Name:	AtReference		
Class	0x2A	Default	N/A
Instance	0x01	Data Type	USINT
Attribute	0x03	Access	Get

Indicates that the drive is running at the requested speed.

Get Pr **0.10.006**

0 = Drive not running at requested speed.

1 = Drive running at requested speed.

NetRef

Name:	NetRef		
Class	0x2A	Default	N/A
Instance	0x01	Data Type	USINT
Attribute	0x04	Access	Get/Set

Selects the source of the speed reference.

Get/Set Pr **0.06.042** bit 8

0 = analog speed reference.

1 = digital speed reference.

NOTE The NetRef can only be changed between local and remote when the drive is configured in speed control mode. If a change is requested when in torque mode then a 'Device State Conflict' error code 0x10 will be returned.

Safety information	Product information	Mechanical installation	Electrical installation	Getting started	Basic parameters	Running the motor	Optimization	Drive communication	NV Media Card Operation	Onboard PLC	Advanced parameters	Diagnostics	UL information
--------------------	---------------------	-------------------------	-------------------------	-----------------	------------------	-------------------	--------------	---------------------	-------------------------	-------------	---------------------	-------------	----------------

DriveMode

Name:	DriveMode		
Class	0x2A	Default	N/A
Instance	0x01	Data Type	USINT
Attribute	0x06	Access	Get/Set

DriveMode does not allow the operating mode of the drive to be changed. Pr **0.04.011** will be written to as shown in Table 9-41 below, provided that the drive is already in the correct operating mode.

Table 9-41 AC/DC Drive object DriveMode attribute (Get)

Access	DriveMode		Actual Drive Mode	Torque Mode (0.4.011)
	Value	Mode		
Get	1	Open Loop Speed	Open-loop	Speed control mode (0)
	2	Closed Loop Speed	RFC-A RFC-S	
	3	Torque Control	Open-loop RFC-A RFC-S	Torque control (3)
	0	User Defined	Regen Don't care	Don't care Torque control with speed override (2) or Coiler / uncoiler mode (3) or Speed control with torque feed forward (4)

Table 9-42 AC/DC Drive object DriveMode attribute (Set)

Access	DriveMode		Actual Drive Mode	Action
	Value	Mode		
Set	0	User Defined	Don't care	Return Invalid Attribute Value (0x09)
	1	Open Loop Speed	Open-loop	Pr 0.04.011 = Speed control mode (0)
			RFC-A or RFC-S or Regen	Return 'Drive state conflict' error (0x10)
			RFC-A or RFC-S	Pr 0.04.011 = Speed control mode (0)
	2	Closed Loop Speed	Open-loop or Regen	Return 'Drive state conflict' error (0x10)
			Open-loop or RFC-A or RFC-S	Pr 0.04.011 = Torque control mode (1)
3	Torque Control	Regen	Return 'Drive state conflict' error (0x10)	

NOTE Pr **0.11.031** will never be changed by setting the DriveMode attribute. An error (0x10) will be generated if the requested DriveMode value does not correspond to the current DriveType operating mode.

SpeedActual

Name:	SpeedActual		
Class	0x2A	Default	N/A
Instance	0x01	Data Type	USINT
Attribute	0x07	Access	Get

Returns the actual speed of the motor in RPM. The source of the motor speed depends on the operating mode of the drive.

- Get Pr **0.05.004** (Open Loop).
- Get Pr **0.03.002** (RFC-A or RFC-S).

SpeedRef

Name:	SpeedRef		
Class	0x2A	Default	N/A
Instance	0x01	Data Type	USINT
Attribute	0x08	Access	Get/Set

Sets or returns the speed reference in RPM.

RFC-A or RFC-S
Get/Set SpeedRef = Pr **0.01.021** (Scaled to 0 decimal places).

Open loop
Get SpeedRef = (Pr **0.01.021** * 60) / Pole Pairs (Scaled to 0 decimal places).
Set Pr **0.01.021** = (SpeedRef * Pole Pairs) / 60 (Scaled to 0 decimal places).

TorqueActual

Name:	TorqueActual		
Class	0x2A	Default	N/A
Instance	0x01	Data Type	USINT
Attribute	0x0B	Access	Get

Returns the actual load on the motor as a percentage of the rated motor load. This attribute has 1 decimal place precision, a value of 1000 represents 100.0 % load.

Get Pr **0.04.020** (Scaled to 1 decimal place).

TorqueRef

Name:	TorqueRef		
Class	0x2A	Default	N/A
Instance	0x01	Data Type	USINT
Attribute	0x0C	Access	Get/Set

Sets the load (torque) reference as % of rated motor load (torque). This attribute has 1 decimal place precision, so a value of 1000 represents 100.0 % load.

Set Pr **0.04.008** = TorqueRef / 10 (Scaled to 1 decimal place).
Get TorqueRef = Pr **0.04.008** * 10 (Scaled to 1 decimal place).

RefFromNet

Name:	RefFromNet		
Class	0x2A	Default	
Instance	0x01	Data Type	USINT
Attribute	0x1D	Access	Get

Indicates the source of the speed reference.

TRUE if Pr **0.01.049** = 3 and Pr **0.01.050** = 1.
FALSE otherwise.

9.5.21 Control Techniques objects

The Control Techniques objects (classes 0x64 to 0x69) allow access to all drive and option module parameters. The class instance number is used to reference the drive or option module menu number (except menu 0) and the class attribute number references the parameter within that menu.

Safety information	Product information	Mechanical installation	Electrical installation	Getting started	Basic parameters	Running the motor	Optimization	Drive communication	NV Media Card Operation	Onboard PLC	Advanced parameters	Diagnostics	UL information
--------------------	---------------------	-------------------------	-------------------------	-----------------	------------------	-------------------	--------------	----------------------------	-------------------------	-------------	---------------------	-------------	----------------

For example, the drive parameter *Percentage Load* (0.04.020) would be accessed as class 0x64, instance 0x04 and attribute 0x14.

An instance value of 0 is invalid therefore to allow access to menu 0 parameters, the instance value 200 (0xC8) must be used.

The number of instances and therefore the number of menus for each class depends on the destination device. If the drive is the destination then the number of menus will depend on the drive operating mode. If the destination is one of the option slots (or onboard Ethernet interface) then the number of menus depends on the type of option module fitted (or the onboard Ethernet interface).

Six individual classes are provided, the following table shows the classes used when accessing the drive or option module parameters.

Table 9-43 Control Techniques object classes

Class Code		Name	Description
Dec	Hex (0x)		
100	64	CT Group	Provides access to all drive parameters
101	65	CT This Slot	Provides access to the connected Ethernet interface parameters
102	66	CT Slot 1	Provides access to the option module in slot 1 parameters
103	67	CT Slot 2	Provides access to the option module in slot 2 parameters
104	68	CT Slot 3	Provides access to the option module in slot 3 parameters
105	69	CT Slot 4	Provides access to the onboard Ethernet interface parameters

9.6 Profinet IO specification (Unidrive M700 / M702)

9.6.1 What is PROFINET?

PROFINET is an Ethernet based industrial network protocol adapting Ethernet hardware and protocols to the real time needs of industrial automation. Profinet enables distributed IO control from a PLC.

9.6.2 Features / Specification

- Dual 100 BASE-TX RJ45 connectors with support for shielded twisted pair, full-duplex 100 M bps connectivity with auto crossover correction
- Both RJ45 ports operate in full duplex mode as a network switch
- PROFINET Real Time class RT_Class_1 and conformance class A
- Cycle times from 1 ms to 512 ms specified during configuration
- Automatic device replacement using the LLDP protocols
- LED indication of network port activity
- Up to 64 cyclic IO module slots (maximum 32 inputs and 32 outputs configured by network configuration tool and GSDML file)
- Identification and Maintenance functions I&M0 to I&M4 supported

NOTE When referring to the cyclic data, the terms input and output are with respect to the PROFINET IO controller (PLC).

NOTE The terms 'network controller' and 'PLC' are mutually used in this manual to refer to the PROFINET network controller. This is generally a PLC with a PROFINET interface and possibly a programming interface to connect to the programming device or PC. However this interface is not necessary, as the PROFINET interface can be used to program the PLC.

9.6.3 GSDML Files

A GSDML (General Station Description Markup Language) file is required to describe the drive interface to a PROFINET controller or PLC. This is an XML file, the structure of which is specified by the PROFIBUS INTERNATIONAL organization (www.profibus.org).

The GSDML file is used in conjunction with the network configuration software to configure the Profinet interface for cyclic data exchange. Many commonly used drive parameters are available as direct mapping 'modules' to be added to the cyclic data 'slots'.

Non-specific 'Flexible modules' are also provided so that the user can allocate a parameter within the drive (or option module), that is not directly available as a specific 'module'. These options will be available from a drop-down selection list within the 'Parameters' tab of the 'module' properties.

The GSDML file can be downloaded from the main Control Techniques company website (www.controltechniques.com), providing you are registered or, alternatively, requested from your local Drive Centre or supplier.

NOTE For further information regarding the use of the GSDML file please refer to the PLC documentation

9.6.4 Network topology

The Ethernet interface has two Ethernet ports with integrated switches to allow the use of line networks. However, when using line networks, a break in the connection (for example when replacing a device) will cause all devices downstream from the failure to also stop communicating with the controller.

Other Ethernet network topologies can be used but care must be taken to ensure that the system still operates within the constraints specified by the designer.

Generally a star or tree network structure using switches gives improved availability in the event of a device failure or replacement.

Safety information	Product information	Mechanical installation	Electrical installation	Getting started	Basic parameters	Running the motor	Optimization	Drive communication	NV Media Card Operation	Onboard PLC	Advanced parameters	Diagnostics	UL information
--------------------	---------------------	-------------------------	-------------------------	-----------------	------------------	-------------------	--------------	----------------------------	-------------------------	-------------	---------------------	-------------	----------------

Although the Profinet protocol does support all major topologies, line networks are normally used for practical or financial reasons, other topologies (e.g. star) may not be suitable for real time communications due to their inherent use of switches or other network equipment.

Any network devices used, such as switches, must be capable of real time communication. Standard office grade equipment is not normally suitable and should not be used in an industrial environment.

NOTE For the device replacement feature to work, the physical network topology must be configured in the controller. For further information please refer to the controller or network configuration software documentation.

9.6.5 Configuring the PROFINET IO communications

No module parameters need to be configured by the user in order to achieve PROFINET cyclic communications. All the necessary configuration is undertaken by the network controller or PLC during the start-up sequence, and after the network configuration is programmed into the network controller or PLC.

It must be noted that when configuring the cyclic data modules, if a module is configured but the associated drive parameter does not actually exist in the drive, then the PLC will not start up correctly and will indicate a configuration fault.

Parameters of slot option module menus can also be configured for cyclic data communication via correctly configured 'Flexible Modules'. The source of the associated parameter can be set to drive or any possible slot within the 'Flexible Module' parameter properties.

9.6.6 Setting the Profinet device name

Each Profinet device must have its own unique device name assigned during network configuration. Device names are used by the controller to communicate with the device for real time messages and alarms. Without a device name the device will not enter data exchange with the controller.

The actual device name is not important to the Profinet system itself, however, a suitable name should be chosen so that it is easily recognised on the network and identifies the location and function of the device.

A typical device name may contain up to four labels, each label is separated by a dot (.) and may be up to 63 characters in length.

The following rules must be observed when choosing the device name:

- Maximum length of 127 characters
- Characters must be lower case letters, numbers, dashes (-) or dots (.)
- The device name must start with a letter and end with either a letter or number
- The device name must not be in the format n.n.n.n (where n is a number from 0 to 999)
- The device name must not begin with the character sequence 'port-xyz' (where x, y and z are numbers from 0 to 9).

A typical example of a device name may be:

motor-1.conveyor-2.line-3.ct-4

The default device name is specified in the GSDML file under the section 'DNS-CompatibleName'.

9.6.7 Profinet transmission cycle (send cycle)

The Profinet transmission cycle is the time required to update all the devices on the Profinet network, the duration of the transmission cycle is determined by the Profinet device with the slowest update rate.

The transmission cycle can be split into a number of phases, where each phase contains one or more devices with similar update rates, the duration of each phase will be equal to the fastest update rate.

Base clock

The base clock is the minimum time unit used and is equal to 31.25 µs.

Send clock factor

The send clock factor determines the duration of each phase and is the number of base clock periods within each phase.

The following table illustrates the relationship between the supported send clock values and the phase duration.

Send Clock Factor	Phase Duration (ms)
32	1
64	2
128	4

Phase duration

The duration (or length) of each phase is determined by the formula:

$$\text{Phase duration} = \text{Send clock factor} \times \text{Base clock.}$$

Reduction ratio

The reduction ratio acts as a multiplier of the minimum update time (or phase duration) and is determined for each device by the formula:

$$\text{Reduction ratio} = \text{Device update time} / \text{Phase duration}$$

Number of phases

The number of phases is determined by the formula:

$$\text{Number of phases} = \text{Send cycle} / \text{fastest update rate.}$$

Example:

In the following example, a system uses four devices, device 1 has an update rate of 8 ms, device 2 has an update rate of 4 ms, device 3 has an update rate of 2 ms and device 4 has an update rate of 1 ms.

Figure 9-5 Profinet transmission cycle

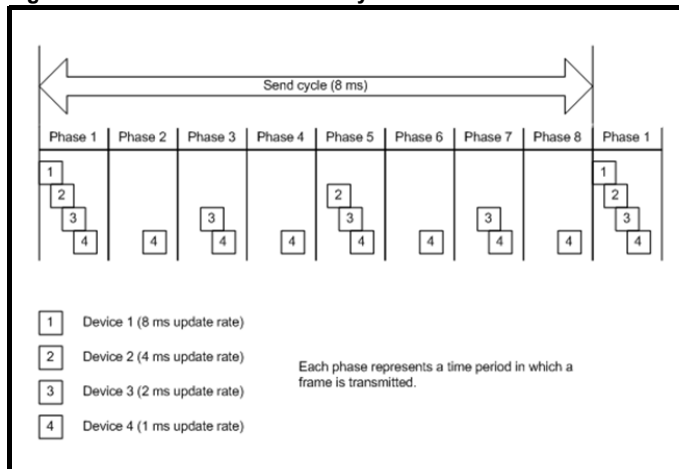

The Profinet transmission cycle is effectively the slowest update rate (8 ms in this example), and the phase duration is effectively the quickest update rate (1 ms in this example).

$$\begin{aligned} \text{Phase duration} &= \text{Send clock factor} \times \text{Base clock} \\ &= 32 \times 31.25 \mu\text{s} = 1 \text{ ms} \end{aligned}$$

$$\text{Reduction ratio} = \text{Device update time} / \text{Phase duration}$$

$$\text{Reduction ratio}_{(\text{device1})} = 8 \text{ ms} / 1 \text{ ms} = 8$$

$$\text{Reduction ratio}_{(\text{device2})} = 4 \text{ ms} / 1 \text{ ms} = 4$$

$$\text{Reduction ratio}_{(\text{device3})} = 2 \text{ ms} / 1 \text{ ms} = 2$$

$$\text{Reduction ratio}_{(\text{device4})} = 1 \text{ ms} / 1 \text{ ms} = 1$$

$$\begin{aligned} \text{Number of phases} &= \text{Send cycle} / \text{fastest update rate} \\ &= 8 \text{ ms} / 1 \text{ ms} = 8 \end{aligned}$$

9.6.8 Update rates

In contrast to some other fieldbus networks, Profinet devices can be configured with different update rates, these rates are specified in the device GSDML file. The Profinet interface on the M700 and M702 supports update rates of 1, 2, 4, 8, 16, 32, 64, 128, 256 and 512 ms.

Safety information	Product information	Mechanical installation	Electrical installation	Getting started	Basic parameters	Running the motor	Optimization	Drive communication	NV Media Card Operation	Onboard PLC	Advanced parameters	Diagnostics	UL information
--------------------	---------------------	-------------------------	-------------------------	-----------------	------------------	-------------------	--------------	---------------------	-------------------------	-------------	---------------------	-------------	----------------

It is recommended that to avoid the possibility of overloading any sections of the Profinet network, the slowest update rate necessary is used.

The update rate can be configured in one of three ways:

- **Automatic** – the update rate selected is the time calculated by the I/O system that can be reliably achieved, based on the configuration.
- **Fixed update time** – the update rate is selected by the user from a list of supported rates specified in the GSDML file
- **Fixed factor** – the update rate is selected by the user from a list of supported rates specified in the GSDML file

NOTE This information only applies to the Siemens I/O configuration system (TIA Portal/SIMATIC STEP7), other I/O configuration systems may provide different configuration options.

9.6.9 Link Layer Discovery Protocol (LLDP)

LLDP is a manufacturer independent layer 2 protocol defined in accordance with the IEEE802.1AB standard.

During start-up and at regular intervals, LLDP messages are used to transfer device information between neighbouring devices. This information includes the device name and connection port numbers. LLDP messages use a special multicast destination MAC address that the IEEE802.1D compliant bridges and switches should not forward.

If all devices in a network support LLDP messages then an accurate network topology view can be presented in the I/O system configuration / diagnostic tool.

9.6.10 Discovery and Configuration Protocol (DCP)

The Discovery and Configuration Protocol is used in the event of a device replacement to automatically configure the new device. All the necessary configuration is done by an appropriate neighbouring device when the new device is detected.

In order to use the network discovery and configuration protocol, the PLC must be correctly configured and programmed with the physical network topology, the following information is intended as a guide only, for more specific information (in particular for other types of PLC's), then please consult the PLC documentation.

NOTE Although the Siemens PLC is mentioned in this manual, Control Techniques does not recommend or endorse any particular PLC or controller manufacturer.

The following information relates to the Siemens S7-1215C PLC. The PLC must be configured to support device replacement, this is an option in the properties of the PROFINET port. In the device configuration screen of the TIA PORTAL application, open the properties of the PLC PROFINET port, click 'Interface options' under 'Advanced options' as shown in Figure 9-6. Ensure the option 'Support device replacement without exchangeable medium' is selected.

Figure 9-6 PLC device replacement option

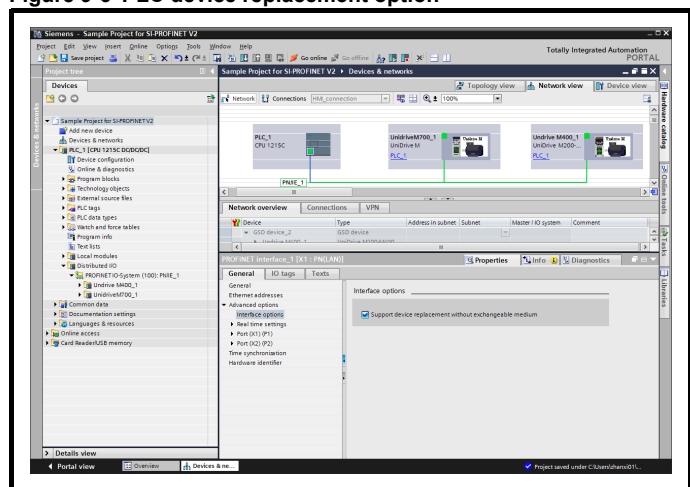

The network topology must now be configured. From the hardware configuration screen, select the port, right click it and select 'PROFINET IO Topology...', the topology editor will be displayed, select the 'Graphic view' tab and using 'drag and drop', connect the relevant device ports together to match the physical network wiring. The program must then be compiled and downloaded to the PLC in the normal manner. Once the PLC has been configured, if a device is replaced then the new device will be automatically configured with the original device's properties, including the device name and IP address.

NOTE For the discovery protocol to work, the replacement device must not have a device name programmed, i.e. it must be blank or unused. If a device name exists in the module and that name is different to the device name set in the network configuration then the PLC will indicate a configuration error and will not enter data exchange with it.

9.6.11 Identification and Maintenance (I&M)

Identification and Maintenance (I&M) functions can be used to read and change various information about devices, such as manufacturer, ordering information, serial number, etc. This information can be used to assist the user in tracking the drive's life cycle through commissioning/start-up, parameterization, diagnosis, repair, etc. The Ethernet interface supports I&M0 to I&M4 inclusively; I&M0 is mandatory for all PROFINET devices, I&M1 to I&M4 are optional. Each I&M function returns specific information about the device and is explained in the following tables.

I&M0

Table 9-44 I&M0 Description

Attribute	Value (Read only)
Manufacturer ID	0x0160
Order ID	SI-PROFINET
Serial number	(Pr S.00.005 x 1,000,000,000 + Pr S.00.004)
Hardware revision	(Pr S.00.003)
Software revision	(Pr S.00.002)
Revision counter	(Pr S.24.006)
Profile ID	(as read)
Profile specific type	(as read)
I&M version	(as read)
I&M supported	(as read)

Manufacturer ID: 2-byte unsigned hexadecimal number assigned by the PROFIBUS business office and specified in the GSDML file. For Control Techniques this value is 0x0160.

Order ID: 20-byte string to identify the device. This value is specified in the GSDML file. For the Ethernet interface this value is 'SI-PROFINET'.

Serial number: 16 character string indicating the module serial number. This value is read from Pr S.00.004 and Pr S.00.005 of the Ethernet interface.

Hardware revision: 2-byte unsigned hexadecimal number indicating the hardware revision of the Ethernet interface. This value is read from Pr S.00.003 of the Ethernet interface.

Software revision: 4-byte value consisting of a single character 'V' and 3 unsigned 8-bit decimal numbers indicating the software revision of the Ethernet interface. This value is taken from Pr S.00.002 of the Ethernet interface.

Revision counter: 2-byte unsigned decimal number. This value will increment by one for each of the following conditions:
 > Drive parameter save
 > Drive parameter default
 > Drive mode change

Will wrap back to 1 after a value of 65535.

Safety information	Product information	Mechanical installation	Electrical installation	Getting started	Basic parameters	Running the motor	Optimization	Drive communication	NV Media Card Operation	Onboard PLC	Advanced parameters	Diagnostics	UL information
--------------------	---------------------	-------------------------	-------------------------	-----------------	------------------	-------------------	--------------	---------------------	-------------------------	-------------	---------------------	-------------	----------------

Profile ID: 2-byte unsigned hexadecimal number indicating the application profile.
 Devices not following any particular profile use the generic profile value 0xF600.

Profile specific type: 2-byte unsigned hexadecimal number indicating the application profile specific type. This value is not applicable to devices using the generic profile and in these instances this value will be zero.

I&M version: 2 unsigned 8-bit numbers indicating the version of the implemented I&M functions.

I&M supported: 2-byte unsigned number indicating the availability of the implemented I&M functions as shown in Table 9-45.

Table 9-45 Supported I&M bit descriptions

Bit	Value	Description
0		Profile specific I&M
1	0	I&M1 Not supported
	1	I&M1 Supported
2	0	I&M2 Not supported
	1	I&M2 Supported
3	0	I&M3 Not supported
	1	I&M3 Supported
4	0	I&M4 Not supported
	1	I&M4 Supported
5 to 15		Reserved

I&M1

Table 9-46 I&M1 Description

Attribute	Value (Read/Write)
Drive function (32 bytes)	(User defined)
Drive location (22 bytes)	(User defined)

Drive function: 32-byte string indicating the drive function.

Drive location: 22-byte string indicating the drive location.

I&M2

Table 9-47 I&M2 Description

Attribute	Value (Read/Write)
Installation date	(User defined)

Installation date: 16-byte string indicating the installation or commissioning date of the device. The installation date is in the format DD/MM/YYYY.

I&M3

Table 9-48 I&M3 Description

Attribute	Value (Read/Write)
Descriptor (54 bytes)	(User defined)

Descriptor: 54-byte string used to store additional information on the location, function or maintenance status of the device.

I&M4

Table 9-49 I&M4 Description

Attribute	Value (Read/Write)
Signature (54 bytes)	(User defined)

Signature: 54-byte octet string used to allow parameterization tools to store a security code as a reference for a particular parameterization session and audit trail tools to retrieve the code for integrity checks.

NOTE

All unused bytes of the I&M functions will be set to 0x20 (space).

10 NV Media Card Operation

10.1 Introduction

The Non-Volatile Media Card feature enables simple configuration of parameters, parameter back-up, storing / reading PLC programs and drive copying using a SMARTCARD or SD card storing / reading PLC programs. The drive offers backward compatibility for a Unidrive SP SMARTCARD and supports NV Media Cards formatted with either FAT16 or FAT32 file system.

The NV Media Card can be used for:

- Parameter copying between drives
- Saving drive parameter sets
- Saving an onboard user program

The NV Media Card is located at the top of the module under the drive display (if installed) on the left-hand side.

Ensure the NV Media Card is inserted with the contacts facing the left-hand side of the drive.

The drive only communicates with the NV Media Card when commanded to read or write, meaning the card may be "hot swapped".



Beware of possible live terminals when installing the NV Media Card.

WARNING

Figure 10-1 Installation of the NV Media Card

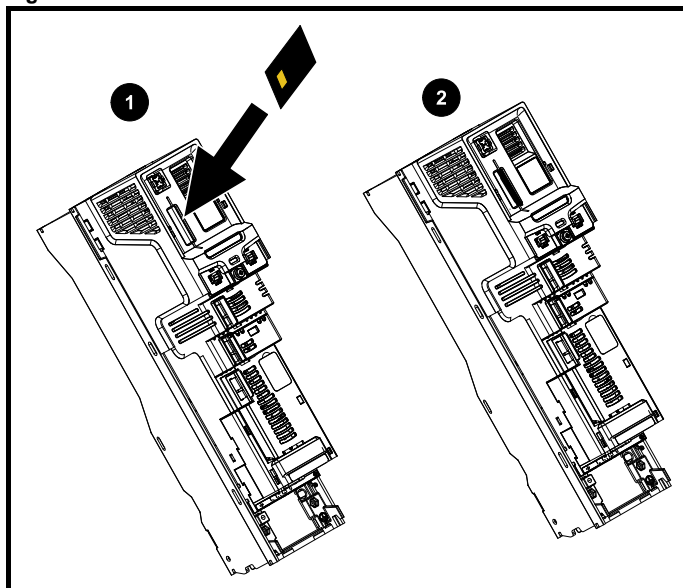

1. Installing the NV Media Card
2. NV Media Card installed

NV Media Card	Part number
SD Card Adaptor (memory card not included)	82400000016400
8 kB SMARTCARD	2214-4246-03
64 kB SMARTCARD	2214-1006-03

10.2 NV Media Card support

The NV Media Card can be used to store drive parameter sets and / or PLC programs set from the Unidrive M in data blocks 001 to 499 on the card.

The Unidrive M is compatible with a Unidrive SP SMARTCARD and is able to read and translate the Unidrive SP parameter set into a compatible parameter set for Unidrive M. This is only possible if the Unidrive SP parameter set was transferred to the SMARTCARD using

the difference from defaults transfer method (i.e. 4yyy transfer). The Unidrive M is not able to read any other type of Unidrive SP data block on the card. Although it is possible to transfer difference from default data blocks from a Unidrive SP into the Unidrive M, the following should be noted:

1. If a parameter from the source drive does not exist in the target drive then no data is transferred for that parameter.
2. If the data for the parameter in the target drive is out of range then the data is limited to the range of the target parameter.
3. If the target drive has a different rating to the source drive then the normal rules for this type of transfer apply.

Figure 10-2 Basic NV Media Card operation

Drive reads all parameters from the NV Media Card







Pr 00.030 = Read + 



Programs all drive parameters to the NV Media Card



Pr 00.030 = Program + 

NOTE
Overwrites any data already in data block 1

Drive automatically writes to the NV Media Card when a parameter save is performed



Auto Save



Pr 00.030 = Auto + 



Boot



Pr 00.030 = Boot + 

Drive boots from the NV Media Card on power up and automatically writes to the NV Media Card when a parameter save is performed

Safety information	Product information	Mechanical installation	Electrical installation	Getting started	Basic parameters	Running the motor	Optimization	Drive communication	NV Media Card Operation	Onboard PLC	Advanced parameters	Diagnostics	UL information
--------------------	---------------------	-------------------------	-------------------------	-----------------	------------------	-------------------	--------------	---------------------	--------------------------------	-------------	---------------------	-------------	----------------

The whole card may be protected from writing or erasing by setting the read-only flag as detailed section 10.3.9 9888 / 9777 - *Setting and clearing the NV Media Card read only flag* on page 141.

The card should not be removed during data transfer, as the drive will produce a trip. If this occurs then either the transfer should be reattempted or in the case of a card to drive transfer, default parameters should be loaded.

10.3 Transferring data

Data transfer, erasing and protecting the information is performed by entering a code in Pr **mm.000** and then resetting the drive as shown in Table 10-1.

Table 10-1 SMARTCARD and SD card codes

Code	Operation	SMARTCARD	SD card
2001	Transfer the drive parameters to parameter file 001 and sets the block as bootable. This will include the parameters from attached option modules.	✓	✓
4yyy	Transfer the drive parameters to parameter file yyy. This will include the parameters from attached option modules.	✓	✓
5yyy	Transfer the onboard user program to onboard user program file yyy.	✓	✓
6yyy	Load the drive parameters from parameter file yyy or the onboard user program from onboard user program file yyy.	✓	✓
7yyy	Erase file yyy.	✓	✓
8yyy	Compare the data in the drive with file yyy. If the files are the same then Pr mm.000 (mm.000) is simply reset to 0 when the compare is complete. If the files are different a 'Card Compare' trip is initiated. All other NV media card trips also apply.	✓	✓
9555	Clear the warning suppression flag	✓	✓
9666	Set the warning suppression flag	✓	✓
9777	Clear the read-only flag	✓	✓
9888	Set the read-only flag	✓	✓
9999	Erase and format the NV media card	✓	

Where yyy indicates the block number 001 to 999.

NOTE

If the read only flag is set then only codes 6yyy or 9777 are effective.

10.3.1 Writing to the NV Media Card

4yyy - Writes defaults differences to the NV Media Card

The data block only contains the parameter differences from the last time default settings were loaded.

All parameters except those with the NC (Not copied) coding bit set are transferred to the NV Media Card. In addition to these parameters all menu 20 parameters (except Pr **20.000**), can be transferred to the NV Media Card.

Writing a parameter set to the NV Media Card (Pr 00.030 = Program (2))

Setting Pr **00.030** to Program (2) and resetting the drive will save the parameters to the NV Media Card, i.e. this is equivalent to writing 4001 to Pr **mm.000**. All NV Media Card trips apply except 'Card Change'. If the data block already exists it is automatically overwritten. When the action is complete this parameter is automatically reset to None (0).

10.3.2 Reading from the NV Media Card

6yyy - Reading from NV Media Card

When the data is transferred back to the drive, using 6yyy in Pr **mm.000**, it is transferred to the drive RAM and the EEPROM. A parameter save is not required to retain the data after-power down. Set up data for any option modules installed stored on the card are transferred to the drive. If the option modules installed are different between source and destination drives, the menus for the option module slots where the option module categories are different are not updated from the card and will contain their default values after the copying action. The drive will produce a 'Card Option' trip if the option module installed to the source and the destination drives are different or are in different slots. If the data is being transferred to the drive with different voltage or current rating a 'Card Rating' trip will occur.

The following drive rating dependant parameters (RA coding bit set) will not be transferred to the destination drive by a NV Media Card when the

voltage rating of the destination drive is different from the source drive and the file is a parameter file.

However, drive rating dependent parameters will be transferred if only the current rating is different. If drive rating dependant parameters are not transferred to the destination drive they will contain their default values.

Pr **02.008** *Standard Ramp Voltage*

Pr **04.005** to Pr **04.007** and Pr **21.027** to Pr **21.029** *Motoring Current Limits*

Pr **04.024**, *User Current Maximum Scaling*

Pr **05.007**, Pr **21.007** *Rated Current*

Pr **05.009**, Pr **21.009** *Rated Voltage*

Pr **05.010**, Pr **21.010** *Rated Power Factor*

Pr **05.017**, Pr **21.012** *Stator Resistance*

Pr **05.018** *Maximum Switching Frequency*

Pr **05.024**, Pr **21.014** *Transient Inductance*

Pr **05.025**, Pr **21.024** *Stator Inductance*

Pr **06.006** *Injection Braking Level*

Pr **06.048** *Supply Loss Detection Level*

Pr **06.065** *Standard Under Voltage Threshold*

Pr **06.066** *Low Under Voltage Threshold*

Pr **06.073** *Braking IGBT Lower Threshold*

Pr **06.074** *Braking IGBT Upper Threshold*

Pr **06.075** *Low Voltage Braking IGBT Threshold*

Reading a parameter set from the NV Media Card (Pr 00.030 = Read (1))

Setting Pr **00.030** to Read (1) and resetting the drive will transfer the parameters from the card into the drive parameter set and the drive EEPROM, i.e. this is equivalent to writing 6001 to Pr **mm.000**.

All NV Media Card trips apply. Once the parameters are successfully copied this parameter is automatically reset to None (0). Parameters are saved to the drive EEPROM after this action is complete.

Safety information	Product information	Mechanical installation	Electrical installation	Getting started	Basic parameters	Running the motor	Optimization	Drive communication	NV Media Card Operation	Onboard PLC	Advanced parameters	Diagnostics	UL information
--------------------	---------------------	-------------------------	-------------------------	-----------------	------------------	-------------------	--------------	---------------------	--------------------------------	-------------	---------------------	-------------	----------------

10.3.3 Auto saving parameter changes (Pr 00.030 = Auto (3))

This setting causes the drive to automatically save any changes made to menu 0 parameters on the drive to the NV Media Card. The latest menu 0 parameter set in the drive is therefore always backed up on the NV Media Card. Changing Pr 00.030 to Auto (3) and resetting the drive will immediately save the complete parameter set from the drive to the card, i.e. all parameters except parameters with the NC coding bit set. Once the whole parameter set is stored only the individual modified menu 0 parameter setting is updated.

Advanced parameter changes are only saved to the NV Media Card when Pr mm.000 is set to 'Save Parameters' or a 1001 and the drive reset.

All NV Media Card trips apply, except 'Card Change'. If the data block already contains information it is automatically overwritten.

If the card is removed when Pr 00.030 is set to 3 Pr 00.030 is then automatically set to None (0).

When a new NV Media Card is installed Pr 00.030 must be set back to Auto (3) by the user and the drive reset so the complete parameter set is rewritten to the new NV Media Card if auto mode is still required.

When Pr 00.030 is set to Auto (3) and the parameters in the drive are saved, the NV Media Card is also updated, and therefore the NV Media Card becomes a copy of the drives stored configuration.

At power up, if Pr 00.030 is set to Auto (3), the drive will save the complete parameter set to the NV Media Card. The drive will display 'Card Write' during this operation. This is done to ensure that if a user puts a new NV Media Card in during power down the new NV Media Card will have the correct data.

NOTE

When Pr 00.030 is set to Auto (3) the setting of Pr 00.030 itself is saved to the drive EEPROM but not the NV Media Card.

10.3.4 Booting up from the NV Media Card on every power up (Pr 00.030 = Boot (4))

When Pr 00.030 is set to Boot (4) the drive operates the same as Auto mode except when the drive is powered-up. The parameters on the NV Media Card will be automatically transferred to the drive at power up if the following are true:

- A card is inserted in the drive
- Parameter data block 1 exists on the card
- The data in block 1 is type 1 to 4 (as defined in Pr 11.038)
- Pr 00.030 on the card set to Boot (4)

The drive will display 'Booting Parameters during this operation. If the drive mode is different from that on the card, the drive gives a 'Card Drive Mode' trip and the data is not transferred.

If 'Boot' mode is stored on the copying NV Media Card this makes the copying NV Media Card the master device. This provides a very fast and efficient way of re-programming a number of drives.

NOTE

'Boot' mode is saved to the card, but when the card is read, the value of Pr 00.030 is not transferred to the drive.

10.3.5 Booting up from the NV Media Card on every power up (Pr mm.000 = 2001)

It is possible to create a bootable parameter data block by setting Pr mm.000 to 2001 and initiating a drive reset. This data block is created in one operation and is not updated when further parameter changes are made.

Setting Pr mm.000 to 2001 will overwrite the data block 1 on the card if it already exists.

10.3.6 8yyy - Comparing the drive full parameter set with the NV Media Card values

Setting 8yyy in Pr mm.000, will compare the NV Media Card file with the data in the drive. If the compare is successful Pr mm.000 is simply set to 0. If the compare fails a 'Card Compare' trip is initiated.

10.3.7 7yyy / 9999 - Erasing data from the NV Media Card values

Data can be erased from the NV Media Card either one block at a time or all blocks in one go.

- Setting 7yyy in Pr mm.000 will erase NV Media Card data block yyy
- Setting 9999 in Pr mm.000 will erase all data blocks on a SMARTCARD, but not on a SD Card.

10.3.8 9666 / 9555 - Setting and clearing the NV Media Card warning suppression flag

If the option modules installed to the source and destination drive are different or are in different slots the drive will produce a 'Card Option' trip. If the data is being transferred to a drive of a different voltage or current rating a 'Card Rating' trip will occur. It is possible to suppress these trips by setting the warning suppression flag. If this flag is set the drive will not trip if the option module(s) or drive ratings are different between the source and destination drives. The options module or rating dependent parameters will not be transferred.

- Setting 9666 in Pr mm.000 will set the warning suppression flag
- Setting 9555 in Pr mm.000 will clear the warning suppression flag

10.3.9 9888 / 9777 - Setting and clearing the NV Media Card read only flag

The NV Media Card may be protected from writing or erasing by setting the read only flag. If an attempt is made to write or erase a data block when the read only flag is set, a 'Card Read Only' trip is initiated. When the read only flag is set only codes 6yyy or 9777 are effective.

- Setting 9888 in Pr mm.000 will set the read only flag
- Setting 9777 in Pr mm.000 will clear the read only flag

10.4 Data block header information

Each data block stored on a NV Media Card has header information detailing the following:

- NV Media Card File Number (11.037)
- NV Media Card File Type (11.038)
- NV Media Card File Version (11.039)
- NV Media Card File Checksum (11.040)

The header information for each data block which has been used can be viewed in Pr 11.038 to Pr 11.040 by increasing or decreasing the data block number set in Pr 11.037. If there is no data on the card Pr 11.037 can only have a value of 0.

10.5 NV Media Card parameters

Table 10-2 Key to parameter table coding

RW	Read / Write	ND	No default value
RO	Read only	NC	Not copied
Num	Number parameter	PT	Protected parameter
Bit	Bit parameter	RA	Rating dependant
Txt	Text string	US	User save
Bin	Binary parameter	PS	Power-down save
FI	Filtered	DE	Destination

11.036 {00.029}		NV Media Card File Previously Loaded					
RO	Num				NC	PT	
OL							
RFC-A	⇕	0 to 999			⇒	0	
RFC-S							

This parameter shows the number of the data block last transferred from a NV Media Card to the drive. If defaults are subsequently reloaded this parameter is set to 0.

Safety information	Product information	Mechanical installation	Electrical installation	Getting started	Basic parameters	Running the motor	Optimization	Drive communication	NV Media Card Operation	Onboard PLC	Advanced parameters	Diagnostics	UL information
--------------------	---------------------	-------------------------	-------------------------	-----------------	------------------	-------------------	--------------	---------------------	-------------------------	-------------	---------------------	-------------	----------------

11.037		NV Media Card File Number												
RW	Num													
OL														
RFC-A	⇕	0 to 999						⇒	0					
RFC-S														

This parameter should have the data block number which the user would like the information displayed in Pr 11.038, Pr 11.039 and Pr 11.040.

11.038		NV Media Card File Type											
RO	Txt				ND	NC	PT						
OL		None (0), Open-loop (1), RFC-A (2), RFC-S (3), Regen (4), User Prog (5), Option App (6)											
RFC-A	⇕												
RFC-S													

Displays the type/mode of the data block selected with Pr 11.037.

Pr 11.038	String	Type / mode
0	None	No file selected
1	Open-loop	Open-loop mode parameter file
2	RFC-A	RFC-A mode parameter file
3	RFC-S	RFC-S mode parameter file
4	Regen	Regen mode parameter file
5	User Prog	Onboard user program file
6	Option App	Option module application file

11.039		NV Media Card File Version												
RO	Num				ND	NC	PT							
OL														
RFC-A	⇕	0 to 9999						⇒						
RFC-S														

Displays the version number of the file selected in Pr 11.037.

11.040		NV Media Card File Checksum												
RO	Num				ND	NC	PT							
OL														
RFC-A	⇕	-2147483648 to 2147483647						⇒						
RFC-S														

Displays the checksum of the data block selected in Pr 11.037.

11.042 {00.030}		Parameter Cloning											
RW	Txt				NC	US*							
OL		None (0), Read (1), Program (2), Auto (3), Boot (4)										None (0)	
RFC-A	⇕												
RFC-S													

* Only a value of 3 or 4 in this parameter is saved.

NOTE

If Pr 11.042 is equal to 1 or 2, this value is not transferred to the drive or saved to the EEPROM. If Pr 11.042 is set to 3 or 4 the value is saved to the EEPROM

None (0) = Inactive

Read (1) = Read parameter set from the NV Media Card

Program (2) = Program a parameter set to the NV Media Card

Auto (3) = Auto save

Boot (4) = Boot mode

11.072		NV Media Card Create Special File												
RW	Num				NC									
OL														
RFC-A	⇕	0 to 1						⇒	0					
RFC-S														

If NV Media Card Create Special File (11.072) = 1 when a parameter file is transferred to an NV media card the file is created as a macro file. NV Media Card Create Special File (11.072) is reset to 0 after the file is created or the transfer fails.

11.073		NV Media Card Type											
RO	Txt				ND	NC	PT						
OL		None (0), SMART Card (1), SD Card (2)											
RFC-A	⇕												
RFC-S													

This will display the type of media card inserted; it will contain one of the following values:

"None" (0) - No NV Media Card has been inserted.

"SMART Card" (1) - A SMARTCARD has been inserted.

"SD Card" (2) - A FAT formatted SD card has been inserted.

11.075		NV Media Card Read-only Flag												
RO	Bit				ND	NC	PT							
OL														
RFC-A	⇕	Off (0) or On (1)						⇒						
RFC-S														

NV Media Card Read-only Flag (11.075) shows the state of the read-only flag for the currently installed card.

11.076		NV Media Card Warning Suppression Flag												
RO	Bit				ND	NC	PT							
OL														
RFC-A	⇕	Off (0) or On (1)						⇒						
RFC-S														

NV Media Card Warning Suppression Flag (11.076) shows the state of the warning flag for the currently installed card.

11.077		NV Media Card File Required Version												
RW	Num				ND	NC	PT							
OL														
RFC-A	⇕	0 to 9999						⇒						
RFC-S														

The value of NV Media Card File Required Version (11.077) is used as the version number for a file when it is created on an NV Media Card. NV Media Card File Required Version (11.077) is reset to 0 when the file is created or the transfer fails.

10.6 NV Media Card trips

After an attempt to read, write or erase data from a NV Media Card a trip is initiated if there has been a problem with the command.

See Chapter 13 *Diagnostics* on page 245 for more information on NV Media Card trips.

Safety information	Product information	Mechanical installation	Electrical installation	Getting started	Basic parameters	Running the motor	Optimization	Drive communication	NV Media Card Operation	Onboard PLC	Advanced parameters	Diagnostics	UL information
--------------------	---------------------	-------------------------	-------------------------	-----------------	------------------	-------------------	--------------	---------------------	-------------------------	--------------------	---------------------	-------------	----------------

11 Onboard PLC

11.1 Onboard PLC and Machine Control Studio

The drive has the ability to store and execute a 16 kB Onboard PLC user program without the need for additional hardware in the form of an option module.

Machine Control Studio is an IEC61131-3 development environment designed for use with Unidrive M and compatible application modules. Machine Control Studio is based on CODESYS from 3S-Smart Software Solutions.

All of the programming languages defined in the IEC standard IEC 61131-3 are supported in the Machine Control Studio development environment.

- ST (Structured text)
- LD (Ladder diagram)
- FBD (Function block diagram)
- IL (Instruction list)
- SFC (Sequential function chart)
- CFC (Continuous Function Chart). CFC is an extension to the standard IEC programming languages

Machine Control Studio provides a complete environment for the development of user programs. Programs can be created, compiled and downloaded to a Unidrive M for execution, via the communications port on the front of the drive. The run-time operation of the compiled program on the target can also be monitored using Machine Control Studio and facilities are provided to interact with the program on the target by setting new values for target variables and parameters.

The Onboard PLC and Machine Control Studio form the first level of functionality in a range of programmable options for Unidrive M.

Machine Control Studio can be downloaded from www.controltechniques.com.

See the Machine Control Studio help file for more information regarding using Machine Control Studio, creating user programs and downloading user programs to the drive.

11.2 Benefits

The combination of the Onboard PLC and Machine Control Studio, means that the drive can replace nano and some micro PLCs in many applications

Machine Control Studio benefits from access to the standard CODESYS function and function block libraries as well as those from third parties. Functions and function blocks available as standard in Machine Control Studio include, but not limited to, the following:

- Arithmetic blocks
- Comparison blocks
- Timers
- Counters
- Multiplexers
- Latches
- Bit manipulation

Typical applications for the Onboard PLC include:

- Ancillary pumps
- Fans and control valves
- Interlocking logic
- Sequences routines
- Custom control words.

11.3 Features

The Unidrive M Onboard PLC user program has the following features:

11.3.1 Tasks

The Onboard PLC allows use of two tasks.

- **Clock:** A high priority real time task. The clock task interval can be set from 4 ms to 262 s in multiples of 4 ms. The parameter *Onboard User Program: Clock Task Time Used* (11.051) shows the percentage of the available time used by clock task. A read or write of a drive parameter by the user program takes a finite period of time. It is possible to select up to 10 parameters as fast access parameter which reduced the amount of time it takes for the user program to read from or write to a drive parameter. This is useful when using a clock task with a fast update rate as selecting a parameter for fast access reduces the amount of the clock task resource required to access parameters.
- **Freewheeling:** A non-real time background task. The freewheeling task is scheduled for a short period once every 64 ms. The time for which the task is scheduled will vary depending on the loading of the drive's processor. When scheduled, several scans of the user program may be performed. Some scans may execute in microseconds. However, when the main drive functions are scheduled there will be a pause in the execution of the program causing some scans to take many milliseconds. The parameter *Onboard User Program: Freewheeling Tasks Per Second* (11.050) shows the number of times the freewheeling task has started per second.

11.3.2 Variables

The Onboard PLC supports the use of variables with the data types of Boolean, integer (8 bit, 16 bit and 32 bit, signed and unsigned), floating point (64 bit only), strings and time.

11.3.3 Custom menu

Machine Control Studio can construct a custom drive menu to reside in menu 30 on the drive. The following properties of each parameter can be defined using Machine Control Studio:

- Parameter name
- Number of decimal places
- The units for the parameter to be display on the keypad.
- The minimum, maximum and default values
- Memory handling (i.e. power down save, user save or volatile)
- Data type. The drive provides a limited set of 1 bit, 8 bit, 16 bit and 32 bit integer parameters to create the customer menu.

Parameters in this customer menu can be accessed by the user program and will appear on the keypad.

11.3.4 Limitations

The Onboard PLC user program has the following limitations:

- The flash memory allocated to the Onboard PLC is 16 kB which includes the user program and its header which results in a maximum user program size of about 12 kB
- The Onboard PLC is provided with 2 kB of RAM.
- The drive is rated for 100 program downloads. This limitation is imposed by the flash memory used to store the program within the drive.
- There is only one real-time task with a minimum period of 4 ms.
- The freewheeling background task runs at a low priority. The drive is prioritized to perform the clock task and its major functions first, e.g. motor control, and will use any remaining processing time to execute the freewheeling task as a background activity. As the drive's processor becomes more heavily loaded, less time is spent executing the freewheeling task.
- Breakpoints, single stepping and online program changes are not possible.
- The Graphing tool is not supported.
- The variable data types REAL (32 bit floating point), LWORD (64 bit integer) and WSTRING (Unicode string), and retained variables are not supported.

Safety information	Product information	Mechanical installation	Electrical installation	Getting started	Basic parameters	Running the motor	Optimization	Drive communication	NV Media Card Operation	Onboard PLC	Advanced parameters	Diagnostics	UL information
--------------------	---------------------	-------------------------	-------------------------	-----------------	------------------	-------------------	--------------	---------------------	-------------------------	--------------------	---------------------	-------------	----------------

11.4 Onboard PLC parameters

The following parameters are associated with the Onboard PLC user program.

11.047		Onboard User Program: Enable			
RW	Txt				US
↕	Stop (0) or Run (1)		⇒		Run (1)

This parameter stops and starts the user program.

0 - Stop the User Program

The onboard user program is stopped. If it is restarted by setting *Onboard User Program: Enable* (11.047) to a non-zero value the background task starts from the beginning.

1 - Run the User Program

The user program will execute.

11.048		Onboard User Program: Status			
RO	Txt		NC	PT	
↕	-2147483648 to 2147483647		⇒		

This parameter is read-only and indicates the status of the user program in the drive. The user program writes the value to this parameter.

0: Stopped

1: Running

2: Exception

3: No user program present

11.049		Onboard User Program: Programming Events			
RO	Uni		NC	PT	PS
↕	0 to 65535		⇒		

This parameter holds the number of times an Onboard PLC user program download has taken place and is 0 on dispatch from the factory. The drive is rated for one hundred program downloads. This parameter is not altered when defaults are loaded.

11.050		Onboard User Program: Freewheeling Tasks Per Second			
RO	Uni		NC	PT	
↕	0 to 65535		⇒		

This parameter shows the number of times the freewheeling task has started per second.

11.051		Onboard User Program: Clock Task Time Used			
RO			NC	PT	
↕	0.0 to 100.0 %		⇒		

This parameter shows the percentage of the available time used by the user program clock task.

11.055		Onboard User Program: Clock Task Scheduled Interval			
RO			NC	PT	
↕	0 to 262128 ms		⇒		

This parameter shows the interval at which the clock task is scheduled to run at in ms.

11.5 Onboard PLC trips

If the drive detects an error in the user program it will initiate a User Program trip. The sub-trip number for the User Program trip details the reason for the error. See Chapter 13 *Diagnostics* on page 245 for more information on the User Program trip.

Safety information	Product information	Mechanical installation	Electrical installation	Getting started	Basic parameters	Running the motor	Optimization	Drive communication	NV Media Card Operation	Onboard PLC	Advanced parameters	Diagnostics	UL information
--------------------	---------------------	-------------------------	-------------------------	-----------------	------------------	-------------------	--------------	---------------------	-------------------------	-------------	----------------------------	-------------	----------------

12 Advanced parameters

This is a quick reference to all parameters in the drive showing units, ranges limits etc, with block diagrams to illustrate their function. Full descriptions of the parameters can be found in the *Parameter Reference Guide*.



These advanced parameters are listed for reference purposes only. The lists in this chapter do not include sufficient information for adjusting these parameters. Incorrect adjustment can affect the safety of the system, and damage the drive and or external equipment. Before attempting to adjust any of these parameters, refer to the *Parameter Reference Guide*.

Table 12-1 Menu descriptions

Menu	Description
0	Commonly used basic set up parameters for quick / easy programming
1	Frequency / Speed reference
2	Ramps
3	Frequency slaving, speed feedback and speed control
4	Torque and current control
5	Motor control
6	Sequencer and clock
7	Analog I/O / Temperature monitoring
8	Digital I/O
9	Programmable logic, motorized pot, binary sum, timers and scope
10	Status and trips
11	Drive set-up and identification, serial communications
12	Threshold detectors and variable selectors
13	Standard motion control
14	User PID controller
15	Option module slot 1 set-up menu
16	Option module slot 2 set-up menu
17	Option module slot 3 set-up menu
18	General option module application menu 1
19	General option module application menu 2
20	General option module application menu 3
21	Second motor parameters
22	Menu 0 set-up
23	Not allocated
24	Ethernet module (slot 4) set-up menu*
25	Option module slot 1 application parameters
26	Option module slot 2 application parameters
27	Option module slot 3 application parameters
28	Option module slot 4 application parameters
29	Reserved menu
30	Onboard user programming application menu
31-41	Advanced motion controller setup parameters
Slot 1	Slot 1 option menus**
Slot 2	Slot 2 option menus**
Slot 3	Slot 3 option menus**
Slot 4	Slot 4 option menus**

* Only displayed on *Unidrive M700 / M702*.

** Only displayed when the option modules are installed.

Operation mode abbreviations:

Open-loop: Sensorless control for induction motors

RFC-A: Asynchronous Rotor Flux Control for induction motors

RFC-S: Synchronous Rotor Flux Control for synchronous motors including permanent magnet motors.

Default abbreviations:

Standard default value (50 Hz AC supply frequency)

USA default value (60 Hz AC supply frequency)

NOTE

Parameter numbers shown in brackets {...} are the equivalent Menu 0 parameters. Some Menu 0 parameters appear twice since their function depends on the operating mode.

The Range - RFC-A / S column applies to both RFC-A and RFC-S. For some parameters, this column applies to only one of these modes, this is indicated accordingly in the Default columns.

In some cases, the function or range of a parameter is affected by the setting of another parameter. The information in the lists relates to the default condition of any parameters affected in this way.

Table 12-2 Key to parameter table coding

Coding	Attribute
RW	Read/Write: can be written by the user
RO	Read only: can only be read by the user
Bit	1 bit parameter. 'On' or 'Off' on the display
Num	Number: can be uni-polar or bi-polar
Txt	Text: the parameter uses text strings instead of numbers.
Bin	Binary parameter
IP	IP Address parameter
Mac	Mac Address parameter
Date	Date parameter
Time	Time parameter
Chr	Character parameter
FI	Filtered: some parameters which can have rapidly changing values are filtered when displayed on the drive keypad for easy viewing.
DE	Destination: This parameter selects the destination of an input or logic function.
RA	Rating dependent: this parameter is likely to have different values and ranges with drives of different voltage and current ratings. Parameters with this attribute will be transferred to the destination drive by non-volatile storage media when the rating of the destination drive is different from the source drive and the file is a parameter file. However, the values will be transferred if only the current rating is different and the file is a difference from default type file.
ND	No default: The parameter is not modified when defaults are loaded
NC	Not copied: not transferred to or from non-volatile media during copying.
PT	Protected: cannot be used as a destination.
US	User save: parameter saved in drive EEPROM when the user initiates a parameter save.
PS	Power-down save: parameter automatically saved in drive EEPROM when the under volts (UV) state occurs.

Safety information	Product information	Mechanical installation	Electrical installation	Getting started	Basic parameters	Running the motor	Optimization	Drive communication	NV Media Card Operation	Onboard PLC	Advanced parameters	Diagnostics	UL information
--------------------	---------------------	-------------------------	-------------------------	-----------------	------------------	-------------------	--------------	---------------------	-------------------------	-------------	---------------------	-------------	----------------

Table 12-3 Feature look-up table

Feature	Related parameters (Pr)												
	02.010	02.011 to 02.019		02.032	02.033	02.034	02.002						
Acceleration rates	02.010	02.011 to 02.019		02.032	02.033	02.034	02.002						
Analog speed reference 1	01.036	07.010	07.001	07.007	07.008	07.009	07.025	07.026	07.030				
Analog speed reference 2	01.037	07.014	01.041	07.002	07.011	07.012	07.013	07.029	07.031				
Analog I/O	Menu 7												
Analog input 1	07.001	07.007	07.008	07.009	07.010	07.025	07.026	07.030					
Analog input 2	07.002	07.011	07.012	07.013	07.014	07.029	07.031						
Analog input 3	07.003	07.015	07.016	07.017	07.018	07.032							
Analog output 1	07.019	07.020											
Analog output 2	07.022	07.023											
Application menu	Menu 18		Menu 19		Menu 20								
At speed indicator bit	03.006	03.007	03.009	10.006	10.005	10.007							
Auto reset	10.034	10.035	10.036	10.001									
Autotune	05.010	05.012	05.017	05.024	05.025	05.029	05.030	05.059	05.060	05.062			
Binary sum	09.029	09.030	09.031	09.032	09.033	09.034							
Bipolar speed	01.010												
Brake control	12.040 to 12.055												
Braking	10.011	10.010	10.030	10.031	06.001	02.004	02.002	10.012	10.039	10.040	10.061		
Catch a spinning motor	06.009	05.040											
Coast to stop	06.001												
Comms	11.023 to 11.027												
Copying	11.042	11.036 to 11.040											
Cost - per kWh electricity	06.016	06.017	06.024	06.025	06.026	06.027	06.028						
Current controller	04.013	04.014											
Current feedback	04.001	04.002	04.017	04.004	04.012	04.020	04.023	04.024	04.026	10.008	10.009	10.017	
Current limits	04.005	04.006	04.007	04.018	04.015	04.019	04.016	05.007	05.010	10.008	10.009	10.017	
DC bus voltage	05.005	02.008											
DC injection braking	06.006	06.007	06.001										
Deceleration rates	02.020	02.021 to 02.029		02.004	02.035 to 02.037		02.002	02.008	06.001	10.030	10.031	10.039	02.009
Defaults	11.043	11.046											
Digital I/O	Menu 8												
Digital I/O read word	08.020												
Digital I/O 1 T24	08.001	08.011	08.021	08.031									
Digital I/O 2 T25	08.002	08.012	08.022	08.032									
Digital I/O 3 T26	08.003	08.013	08.023	08.033									
Digital input 4 T27	08.004	08.014	08.024										
Digital input 5 T28	08.005	08.015	08.025										
Digital input 6 T29	08.006	08.016	08.026										
Digital lock	13.010	13.001 to 13.009			13.011	13.012	13.016	03.022	03.023	13.019 to 13.023			
Digital output T22	08.008	08.018	08.028										
Direction	10.013	06.030	06.031	01.003	10.014	02.001	03.002	08.003	08.004	10.040			
Drive active	10.002	10.040											
Drive derivative	11.028												
Drive OK	10.001	08.027	08.007	08.017	10.036	10.040							
Dynamic performance	05.026												
Dynamic V/F	05.013												
Enable	06.015	08.009	08.040										
Encoder reference	03.043	03.044	03.045	03.046									
Encoder set-up	03.033	03.034 to 03.042			03.047	03.048							
External trip	10.032	08.010	08.007										
Fan speed	06.045												
Fast disable	06.029												
Field weakening - induction motor	05.029	05.030	01.006	05.028	05.062	05.063							
Field weakening - servo	05.022	01.006	05.009										
Filter change	06.019	06.018	06.021	06.022	06.023								
Frequency reference selection	01.014	01.015											
Frequency slaving	03.001	03.013	03.014	03.015	03.016	03.017							
Hard speed reference	03.022	03.023											
Heavy duty rating	05.007	11.032											
High stability space vector modulation	05.019												
I/O sequencer	06.030	06.031	06.032	06.033	06.034	06.042	06.043	06.041					
Inertia compensation	02.038	05.012	04.022	03.018									

Safety information	Product information	Mechanical installation	Electrical installation	Getting started	Basic parameters	Running the motor	Optimization	Drive communication	NV Media Card Operation	Onboard PLC	Advanced parameters	Diagnostics	UL information
--------------------	---------------------	-------------------------	-------------------------	-----------------	------------------	-------------------	--------------	---------------------	-------------------------	-------------	---------------------	-------------	----------------

Feature	Related parameters (Pr)												
Jog reference	01.005	02.019	02.029										
Keypad reference	01.017	01.014	01.043	01.051	06.012	06.013							
Kt	05.032												
Limit switches	06.035	06.036											
Line power supply loss	06.003	10.015	10.016	05.005	06.048								
Local position reference	13.020 to 13.023												
Logic function 1	09.001	09.004	09.005	09.006	09.007	09.008	09.009	09.010					
Logic function 2	09.002	09.014	09.015	09.016	09.017	09.018	09.019	09.020					
Low voltage supply	06.044												
Marker pulse	03.032	03.031											
Maximum speed	01.006												
Menu 0 set-up	11.018 to 11.022			Menu 22									
Minimum speed	01.007	10.004											
Modules - number of	11.035												
Motor map	05.006	05.007	05.008	05.009	05.010	05.011							
Motor map 2	Menu 21		11.45										
Motorized potentiometer	09.021	09.022	09.023	09.024	09.025	09.026	09.027	09.028					
Offset speed reference	01.004	01.038	01.009										
Onboard PLC	11.047 to 11.051												
Open loop vector mode	05.014	05.017											
Operating mode	00.048	11.031	03.024	05.014									
Orientation	13.010	13.013 to 13.015											
Output	05.001	05.002	05.003	05.004									
Overspeed threshold	03.008												
Phase angle	03.025	05.012											
PID controller	Menu 14												
Position feedback - drive	03.028	03.029	03.030	03.050									
Positive logic	08.029												
Power up parameter	11.022	11.021											
Precision reference	01.018	01.019	01.020	01.044									
Preset speeds	01.015	01.021 to 01.028			01.016	01.014	01.042	01.045 to 01.048		01.050			
Programmable logic	Menu 9												
Quasi square operation	05.020												
Ramp (accel / decel) mode	02.004	02.008	06.001	02.002	02.003	10.030	10.031	10.039					
Rated speed autotune	05.016	05.008											
Regenerating	10.010	10.011	10.030	10.031	06.001	02.004	02.002	10.012	10.039	10.040			
Relative jog	13.017 to 13.019												
Relay output	08.007	08.017	08.027										
Reset	10.033	08.002	08.022	10.034	10.035	10.036	10.001	10.038					
RFC mode (encoder less CLV mode)	03.024	03.042	04.012										
S ramp	02.006	02.007											
Sample rates	05.018												
Safe Torque Off input	08.009	08.040											
Security code	11.030	11.044											
Serial comms	11.023 to 11.027			11.020									
Skip speeds	01.029	01.030	01.031	01.032	01.033	01.034	01.035						
Slip compensation	05.027	05.008											
NV media card	11.036 to 11.040			11.042									
Firmware version	11.029	11.034	11.062										
Speed controller	03.010 to 03.017			03.019	03.020	03.021							
Speed feedback	03.002	03.003	03.004										
Speed feedback - drive	03.026	03.027	03.028	03.029	03.030	03.031	03.042						
Speed feed forward	01.039	01.040											
Speed reference selection	01.014	01.015	01.049	01.050	01.001								
Status word	10.040												
Supply	06.044	05.005											
Switching frequency	05.018	05.035	07.034	07.035									
Thermal protection - drive	05.018	05.035	07.004	07.005	07.006	07.034	07.035	07.036	10.018				
Thermal protection - motor	04.015	05.007	04.019	04.016	04.025	07.015							
Thermistor input	07.003	07.015	07.046	07.047	07.048	07.049	07.050						
Threshold detector 1	12.001	12.003 to 12.007											
Threshold detector 2	12.002	12.023 to 12.027											
Time - filter change	06.019	06.018	06.021	06.022	06.023								
Time - powered up log	06.019	06.020											

Safety information	Product information	Mechanical installation	Electrical installation	Getting started	Basic parameters	Running the motor	Optimization	Drive communication	NV Media Card Operation	Onboard PLC	Advanced parameters	Diagnostics	UL information
--------------------	---------------------	-------------------------	-------------------------	-----------------	------------------	-------------------	--------------	---------------------	-------------------------	-------------	---------------------	-------------	----------------

Feature	Related parameters (Pr)												
Time - run log	06.019												
Torque	04.003	04.026	05.032										
Torque mode	04.008	04.011	04.009	04.010									
Trip detection	10.037	10.038	10.020 to 10.029										
Trip log	10.020 to 10.029			10.041 to 10.060			10.070 to 10.079						
Under voltage	05.005	10.016	10.015										
V/F mode	05.015	05.014											
Variable selector 1	12.008 to 12.016												
Variable selector 2	12.028 to 12.036												
Voltage controller	05.031												
Voltage mode	05.014	05.017		05.015									
Voltage rating	11.033	05.009	05.005										
Voltage supply	06.044		05.005										
Warning	10.019	10.012	10.017	10.018	10.040								
Zero speed indicator bit	03.005	10.003											

12.1 Parameter ranges and Variable minimum/maximums

Some parameters in the drive have a variable range with a variable minimum and a variable maximum value which is dependent on one of the following:

- The settings of other parameters
- The drive rating
- The drive mode
- Combination of any of the above

The tables below give the definition of variable minimum/maximum and the maximum range of these.

VM_AC_VOLTAGE		Range applied to parameters showing AC voltage
Units	V	
Range of [MIN]	0	
Range of [MAX]	0 to 930	
Definition	VM_AC_VOLTAGE[MAX] is drive voltage rating dependent. See Table 12-4 VM_AC_VOLTAGE[MIN] = 0	

VM_AC_VOLTAGE_SET		Range applied to the AC voltage set-up parameters
Units	V	
Range of [MIN]	0	
Range of [MAX]	0 to 690	
Definition	VM_AC_VOLTAGE[MAX] is drive voltage rating dependent. See Table 12-4 VM_AC_VOLTAGE[MIN] = 0	

VM_ACCEL_RATE		Maximum applied to the ramp rate parameters
Units	s / 100 Hz, s / 1000 rpm, s / 1000 mm/s	
Range of [MIN]	Open-loop: 0.0 RFC-A, RFC-S: 0.000	
Range of [MAX]	Open-loop: 0.0 to 3200.0 RFC-A, RFC-S: 0.000 to 3200.000	
Definition	Open-loop mode If <i>Ramp Rate Units</i> (02.039) = 0: VM_ACCEL_RATE[MAX] = 3200.0 If <i>Ramp Rate Units</i> (02.039) = 1: VM_ACCEL_RATE[MAX] = 3200.0 x Pr 01.006 / 100.0 VM_ACCEL_RATE[MIN] = 0.0 RFC-A, RFC-S modes If <i>Ramp Rate Units</i> (02.039) = 0: VM_ACCEL_RATE[MAX] = 3200.000 If <i>Ramp Rate Units</i> (02.039) = 1: VM_ACCEL_RATE[MAX] = 3200.000 x Pr 01.006 / 1000.0 VM_ACCEL_RATE[MIN] = 0.000 If the second motor map is selected (Pr 11.045 = 1) Pr 21.001 is used instead of Pr 01.006 .	

Safety information	Product information	Mechanical installation	Electrical installation	Getting started	Basic parameters	Running the motor	Optimization	Drive communication	NV Media Card Operation	Onboard PLC	Advanced parameters	Diagnostics	UL information
--------------------	---------------------	-------------------------	-------------------------	-----------------	------------------	-------------------	--------------	---------------------	-------------------------	-------------	---------------------	-------------	----------------

VM_AMC_JERK_UNIPOLAR		Range applied to the parameters showing the AMC jerk	
Units	User units / ms / ms / ms		
Range of [MIN]	0		
Range of [MAX]	107374.1823		
Definition	VM_AMC_JERK_UNIPOLAR[MAX] = 107374.1823 / AMC Auto Resolution Scaling (31.016) VM_AMC_JERK_UNIPOLAR[MIN] = 0		

VM_AMC_POSITION		Range applied to the parameters showing the AMC position	
Unit	User units		
Range of [MIN]	-2147483648		
Range of [MAX]	2147483647		
Definition	VM_AMC_POSITION is modified by AMC Auto Resolution Scaling (31.016) and AMC Roll Over Limit (31.010). See the table below.		
	AMC Roll Over Limit (31.010)	= 0	> 0
	VM_AMC_POSITION[MAX]	2147483647 / AMC Auto Resolution Scaling (31.016)	AMC Roll Over Limit (31.010) - 1
	VM_AMC_POSITION[MIN]	-2147483648 / AMC Auto Resolution Scaling (31.016)	0

VM_AMC_POSITION_CAM		Range applied to the parameters showing the AMC cam position	
Unit	User units		
Range of [MIN]	-1073741824		
Range of [MAX]	1073741823		
Definition	VM_AMC_POSITION_CAM is modified by AMC Auto Resolution Scaling (31.016) and AMC Roll Over Limit (31.010). See the table below.		
	AMC Roll Over Limit (31.010)	= 0	> 0
	VM_AMC_POSITION_CAM[MAX]	1073741823 / AMC Auto Resolution Scaling (31.016)	AMC Roll Over Limit (31.010) - 1
	VM_AMC_POSITION_CAM[MIN]	-1073741824 / AMC Auto Resolution Scaling (31.016)	-AMC Roll Over Limit (31.010) + 1

VM_AMC_POSITION_CAM_UNIPOLAR		Unipolar version of VM_AMC_POSITION_CAM	
Unit	User units		
Range of [MIN]	0		
Range of [MAX]	1073741823		
Definition	VM_AMC_POSITION_CAM_UNIPOLAR is modified by AMC Auto Resolution Scaling (31.016) and AMC Roll Over Limit (31.010). See the table below. .		
	AMC Roll Over Limit (31.010)	= 0	> 0
	VM_AMC_POSITION_CAM_UNIPOLAR[MAX]	1073741823 / AMC Auto Resolution Scaling (31.016)	AMC Roll Over Limit (31.010) - 1
	VM_AMC_POSITION_CAM_UNIPOLAR[MIN]	0	0

VM_AMC_POSITION_REF		Range applied to the AMC position reference	
Unit	User units		
Range of [MIN]	-2147483648		
Range of [MAX]	2147483647		
Definition	VM_AMC_POSITION_REF is modified by AMC Auto Resolution Scaling (31.016), AMC Roll Over Limit (31.010) and AMC Rotary Mode (34.005). See the table below.		
	AMC Roll Over Limit (31.010)	= 0	> 0
	AMC Rotary Mode (34.005)	Not active	= 4
	VM_AMC_POSITION_REF[MAX]	2147483647 / AMC Auto Resolution Scaling (31.016)	AMC Roll Over Limit (31.010) - 1
	VM_AMC_POSITION_REF[MIN]	-2147483648 / AMC Auto Resolution Scaling (31.016)	0
			1073741823 / AMC Auto Resolution Scaling (31.016)
			-1073741824 / AMC Auto Resolution Scaling (31.016)

Safety information	Product information	Mechanical installation	Electrical installation	Getting started	Basic parameters	Running the motor	Optimization	Drive communication	NV Media Card Operation	Onboard PLC	Advanced parameters	Diagnostics	UL information
--------------------	---------------------	-------------------------	-------------------------	-----------------	------------------	-------------------	--------------	---------------------	-------------------------	-------------	---------------------	-------------	----------------

VM_AMC_POSITION_UNIPOLAR		Unipolar version of VM_AMC_POSITION	
Unit	User units		
Range of [MIN]	0		
Range of [MAX]	2147483647		
Definition	VM_AMC_POSITION_UNIPOLAR is modified by <i>AMC Auto Resolution Scaling</i> (31.016) and <i>AMC Roll Over Limit</i> (31.010). See the table below.		
	AMC Roll Over Limit (31.010)	= 0	> 0
	VM_AMC_POSITION_UNIPOLAR[MAX]	2147483647 / <i>AMC Auto Resolution Scaling</i> (31.016)	<i>AMC Roll Over Limit</i> (31.010) - 1
	VM_AMC_POSITION_UNIPOLAR[MIN]	0	0

VM_AMC_RATE		Range applied to the parameters showing the AMC acceleration	
Unit	User units / ms / ms		
Range of [MIN]	1073742.824		
Range of [MAX]	1073741.823		
Definition	VM_AMC_RATE_UNIPOLAR[MAX] = 1073741.823 / <i>AMC Auto Resolution Scaling</i> (31.016)		
	VM_AMC_RATE_UNIPOLAR[MIN] = 1073741.824 / <i>AMC Auto Resolution Scaling</i> (31.016)		

VM_AMC_RATE_UNIPOLAR		Unipolar version of VM_AMC_RATE	
Unit	User units / ms / ms		
Range of [MIN]	0		
Range of [MAX]	1073741.823		
Definition	VM_AMC_RATE_UNIPOLAR[MAX] = 1073741.823 / <i>AMC Auto Resolution Scaling</i> (31.016)		
	VM_AMC_RATE_UNIPOLAR[MIN] = 0		

VM_AMC_ROLLOVER		Maximum applied to the AMC Rollover parameter	
Unit	User units / ms / ms		
Range of [MIN]	0		
Range of [MAX]	1073741823		
Definition	VM_AMC_ROLLOVER[MAX] = 1073741823 / <i>AMC Auto Resolution Scaling</i> (31.016)		
	VM_AMC_ROLLOVER[MIN] = 0		

VM_AMC_SPEED		Range applied to the parameters showing the AMC speed	
Unit	User units / ms / ms		
Range of [MIN]	-21474836.48		
Range of [MAX]	21474836.47		
Definition	VM_AMC_SPEED[MAX] = 21474836.47 / <i>AMC Auto Resolution Scaling</i> (31.016)		
	VM_AMC_SPEED[MIN] = -21474836.48 / <i>AMC Auto Resolution Scaling</i> (31.016)		

VM_AMC_SPEED_UNIPOLAR		Unipolar version of VM_AMC_SPEED	
Unit	User units / ms		
Range of [MIN]	0		
Range of [MAX]	21474836.47		
Definition	VM_SPEED_UNIPOLAR[MAX] = 21474836.47 / <i>AMC Auto Resolution Scaling</i> (31.016)		
	VM_SPEED_UNIPOLAR[MIN] = 0		

VM_DC_VOLTAGE		Range applied to parameters showing DC voltage	
Units	V		
Range of [MIN]	0		
Range of [MAX]	0 to 1190		
Definition	VM_DC_VOLTAGE[MAX] is the full scale d.c. link voltage feedback (over voltage trip level) for the drive. This level is drive voltage rating dependent. See Table 12-4.		
	VM_DC_VOLTAGE[MIN] = 0		

Safety information	Product information	Mechanical installation	Electrical installation	Getting started	Basic parameters	Running the motor	Optimization	Drive communication	NV Media Card Operation	Onboard PLC	Advanced parameters	Diagnostics	UL information
--------------------	---------------------	-------------------------	-------------------------	-----------------	------------------	-------------------	--------------	---------------------	-------------------------	-------------	---------------------	-------------	----------------

VM_DC_VOLTAGE_SET		Range applied to DC voltage reference parameters
Units	V	
Range of [MIN]	0	
Range of [MAX]	0 to 1150	
Definition	VM_DC_VOLTAGE_SET[MAX] is drive voltage rating dependent. See Table 12-4. VM_DC_VOLTAGE_SET[MIN] = 0	

VM_DRIVE_CURRENT		Range applied to parameters showing current in A
Units	A	
Range of [MIN]	-99999.999 to 0.000	
Range of [MAX]	0.000 to 99999.999	
Definition	VM_DRIVE_CURRENT[MAX] is equivalent to the full scale (over current trip level) for the drive and is given by <i>Full Scale Current Kc</i> (11.061). VM_DRIVE_CURRENT[MIN] = - VM_DRIVE_CURRENT[MAX]	

VM_DRIVE_CURRENT_UNIPOLAR		Unipolar version of VM_DRIVE_CURRENT
Units	A	
Range of [MIN]	0.000	
Range of [MAX]	0.000 to 99999.999	
Definition	VM_DRIVE_CURRENT_UNIPOLAR[MAX] = VM_DRIVE_CURRENT[MAX] VM_DRIVE_CURRENT_UNIPOLAR[MIN] = 0.000	

VM_HIGH_DC_VOLTAGE		Range applied to parameters showing high DC voltage
Units	V	
Range of [MIN]	0	
Range of [MAX]	0 to 1500	
Definition	VM_HIGH_DC_VOLTAGE[MAX] is the full scale d.c. link voltage feedback for the high d.c. link voltage measurement which can measure the voltage if it goes above the normal full scale value. See Table 12-4 VM_HIGH_DC_VOLTAGE[MIN] = 0	

VM_LOW_UNDER_VOLTS		Range applied to the low under-voltage threshold
Units	V	
Range of [MIN]	24	
Range of [MAX]	24 to 1150	
Definition	If <i>Back-up Mode Enable</i> (06.068) = 0: VM_LOW_UNDER_VOLTS[MAX] = VM_STD_UNDER_VOLTS[MIN] If <i>Back-up Mode Enable</i> (06.068) = 1: VM_LOW_UNDER_VOLTS[MAX] = VM_STD_UNDER_VOLTS[MIN] / 1.1. VM_LOW_UNDER_VOLTS[MIN] = 24.	

VM_MIN_SWITCHING_FREQUENCY		Range applied to the minimum switching frequency parameter
Units	User units	
Range of [MIN]	0	
Range of [MAX]	0 to 6	
Definition	VM_MIN_SWITCHING_FREQUENCY[MAX] = <i>Maximum Switching Frequency</i> (05.018) VM_MIN_SWITCHING_FREQUENCY[MIN] = 0 for motor control modes, or 1 for Regen mode (subject to the maximum)	

Safety information	Product information	Mechanical installation	Electrical installation	Getting started	Basic parameters	Running the motor	Optimization	Drive communication	NV Media Card Operation	Onboard PLC	Advanced parameters	Diagnostics	UL information
--------------------	---------------------	-------------------------	-------------------------	-----------------	------------------	-------------------	--------------	---------------------	-------------------------	-------------	---------------------	-------------	----------------

VM_MOTOR1_CURRENT_LIMIT VM_MOTOR2_CURRENT_LIMIT		Range applied to current limit parameters
Units	%	
Range of [MIN]	0.0	
Range of [MAX]	0.0 to 1000.0	
Definition	VM_MOTOR1_CURRENT_LIMIT[MIN] = 0.0	
	<p>Open-loop VM_MOTOR1_CURRENT_LIMIT[MAX] = (I_{Tlimit} / I_{Trated}) x 100 % Where: $I_{Tlimit} = I_{MaxRef} \times \cos(\sin^{-1}(I_{Mrated} / I_{MaxRef}))$ $I_{Mrated} = Pr\ 05.007 \sin \phi$ $I_{Trated} = Pr\ 05.007 \times \cos \phi$ $\cos \phi = Pr\ 05.010$ I_{MaxRef} is 0.7 x Pr 11.061 when the motor rated current set in Pr 05.007 is less than or equal to Pr 11.032 (i.e. Heavy duty), otherwise it is the lower of 0.7 x Pr 11.061 or 1.1 x Pr 11.060 (i.e. Normal duty).</p>	
	<p>RFC-A VM_MOTOR1_CURRENT_LIMIT[MAX] = (I_{Tlimit} / I_{Trated}) x 100 % Where: $I_{Tlimit} = I_{MaxRef} \times \cos(\sin^{-1}(I_{Mrated} / I_{MaxRef}))$ $I_{Mrated} = Pr\ 05.007 \times \sin \phi_1$ $I_{Trated} = Pr\ 05.007 \times \cos \phi_1$ $\phi_1 = \cos^{-1}(Pr\ 05.010) + \phi_2$. ϕ_1 is calculated during an autotune. See the variable minimum / maximum calculations in the <i>Parameter Reference Guide</i> for more information regarding ϕ_2. I_{MaxRef} is 0.9 x Pr 11.061 when the motor rated current set in Pr 05.007 is less than or equal to Pr 11.032 (i.e. Heavy duty), otherwise it is the lower of 0.9 x Pr 11.061 or 1.1 x Pr 11.060 (i.e. Normal duty).</p>	
	<p>RFC-S and Regen VM_MOTOR1_CURRENT_LIMIT[MAX] = (I_{MaxRef} / Pr 05.007) x 100 % Where: I_{MaxRef} is 0.9 x Pr 11.061 when the motor rated current set in Pr 05.007 is less than or equal to Pr 11.032 (i.e. Heavy duty), otherwise it is the lower of 0.9 x Pr 11.061 or 1.1 x Pr 11.060 (i.e. Normal duty).</p>	
	For VM_MOTOR2_CURRENT_LIMIT[MAX] use Pr 21.007 instead of Pr 05.007 and Pr 21.010 instead of Pr 05.010 .	

VM_NEGATIVE_REF_CLAMP1 VM_NEGATIVE_REF_CLAMP2		Limits applied to the negative frequency or speed clamp																	
Units	Open-loop: Hz RFC-A, RFC-S: rpm or mm/s																		
Range of [MIN]	Open-loop: -599.0 to 0.0 RFC-A, RFC-S: -50000.0 to 0.0																		
Range of [MAX]	Open-loop: 0.0 to 599.0 RFC-A, RFC-S: 0.0 to 50000.0																		
Definition	<table border="1"> <thead> <tr> <th>Negative Reference Clamp Enable (01.008)</th> <th>Bipolar Reference Enable (01.010)</th> <th>VM_NEGATIVE_REF_CLAMP1[MIN]</th> <th>VM_NEGATIVE_REF_CLAMP1[MAX]</th> </tr> </thead> <tbody> <tr> <td>0</td> <td>0</td> <td>0.0</td> <td>Pr 01.006</td> </tr> <tr> <td>0</td> <td>1</td> <td>0.0</td> <td>0.0</td> </tr> <tr> <td>1</td> <td>X</td> <td>-VM_POSITIVE_REF_CLAMP1[MAX]</td> <td>0.0</td> </tr> </tbody> </table>	Negative Reference Clamp Enable (01.008)	Bipolar Reference Enable (01.010)	VM_NEGATIVE_REF_CLAMP1[MIN]	VM_NEGATIVE_REF_CLAMP1[MAX]	0	0	0.0	Pr 01.006	0	1	0.0	0.0	1	X	-VM_POSITIVE_REF_CLAMP1[MAX]	0.0		
	Negative Reference Clamp Enable (01.008)	Bipolar Reference Enable (01.010)	VM_NEGATIVE_REF_CLAMP1[MIN]	VM_NEGATIVE_REF_CLAMP1[MAX]															
	0	0	0.0	Pr 01.006															
	0	1	0.0	0.0															
1	X	-VM_POSITIVE_REF_CLAMP1[MAX]	0.0																
VM_NEGATIVE_REF_CLAMP2 is defined in the same way except that Pr 21.001 is used instead of Pr 01.006 .																			

VM_POSITIVE_REF_CLAMP1 VM_POSITIVE_REF_CLAMP2		Limits applied to the positive frequency or speed reference clamp
Units	Open-loop: Hz RFC-A, RFC-S: rpm or mm/s	
Range of [MIN]	Open-loop: 0.0 RFC-A, RFC-S: 0.0	
Range of [MAX]	Open-loop: 599.0 RFC-A, RFC-S: 0.0 to 550 x 60 / Motor pole pairs	
Definition	VM_POSITIVE_REF_CLAMP1[MAX] defines the range of the positive reference clamp, <i>Maximum Reference Clamp</i> (01.006), which in turn limit the references. In RFC-A and RFC-S modes a limit is applied so that the position feedback does not exceed the speed where the drive can no longer interpret the feedback signal correctly as given in the table below. The limit is based on the position feedback device selected with <i>Motor Control Feedback Select</i> (03.026). It is possible to disable this limit if the <i>RFC Feedback Mode</i> (03.024) ≥ 1 (i.e. VM_POSITIVE_REF_CLAMP1 = 50000.0), so that the motor can be operated at a speed above the level where the drive can interpret the feedback in sensorless mode. It should be noted that the position feedback device itself may have a maximum speed limit that is lower than those given in the table. Care should be taken not to exceed a speed that would cause damage to the position feedback device.	
	Feedback device	VM_POSITIVE_REF_CLAMP1[MAX]
	AB, AB Servo	(500 kHz x 60 / rotary lines per revolution) rpm (500 kHz x linear line pitch in mm) mm/s
	FD, FR, FD Servo, FR Servo	(500 kHz x 60 / rotary lines per revolution)/2 rpm (500 kHz x linear line pitch in mm)/2 mm/s
	SC, SC Hiper, SC EnDat, SC SSI, SC Servo	(500 kHz x 60 / sine waves per revolution) rpm (500 kHz x linear line pitch in mm) mm/s
	Resolver	30000 rpm (250 Hz x pole pitch in mm) mm/s
	Any other device	50000.0 rpm or mm/s
In open-loop mode VM_POSITIVE_REF_CLAMP1[MAX] is fixed at 599.0 Hz		
In RFC mode a limit is applied to the speed reference of 550 x 60 / Motor pole pairs. Therefore, with a 4 pole motor the limit for VM_POSITIVE_REF_CLAMP1[MAX] will be 16,500 rpm.		
VM_POSITIVE_REF_CLAMP1[MIN] = 0.0		
VM_POSITIVE_REF_CLAMP2 is defined in the same way as VM_POSITIVE_REF_CLAMP1 except		
VM_POSITIVE_REF_CLAMP2[MAX] defines the range of the positive reference clamp, <i>M2 Maximum Reference Clamp</i> (21.001), which in turn limits the references.		

VM_POWER		Range applied to parameters that either set or display power
Units	kW	
Range of [MIN]	-99999.999 to 0.000	
Range of [MAX]	0.000 to 99999.999	
Definition	VM_POWER[MAX] is rating dependent and is chosen to allow for the maximum power that can be output by the drive with maximum a.c. output voltage, at maximum controlled current and unity power factor.	
	$VM_POWER[MAX] = \sqrt{3} \times VM_AC_VOLTAGE[MAX] \times VM_DRIVE_CURRENT[MAX] / 1000$	
	VM_POWER[MIN] = -VM_POWER[MAX]	

VM_RATED_CURRENT		Range applied to rated current parameters
Units	A	
Range of [MIN]	0.000	
Range of [MAX]	0.000 to 99999.999	
Definition	VM_RATED_CURRENT [MAX] = <i>Maximum Rated Current</i> (11.060) and is dependent on the drive rating. This is the Normal Duty rating of the drive.	
	VM_RATED_CURRENT [MIN] = 0.000	

Safety information	Product information	Mechanical installation	Electrical installation	Getting started	Basic parameters	Running the motor	Optimization	Drive communication	NV Media Card Operation	Onboard PLC	Advanced parameters	Diagnostics	UL information
--------------------	---------------------	-------------------------	-------------------------	-----------------	------------------	-------------------	--------------	---------------------	-------------------------	-------------	---------------------	-------------	----------------

VM_REGEN_REACTIVE		Range applied to the reactive current reference in Regen mode
Units	%	
Range of [MIN]	-1000.0 to 0.0	
Range of [MAX]	0.0 to 1000.0	
Definition	<p>VM_REGEN_REACTIVE[MAX] Applies a limit to the reactive current reference in Regen mode so that the total current reference does not exceed its maximum allowed level.</p> <p>VM_REGEN_REACTIVE[MIN] = - VM_REGEN_REACTIVE[MAX]</p>	

VM_SPEED		Range applied to parameters showing speed
Units	Open-loop, RFC-A, RFC-S: rpm or mm/s	
Range of [MIN]	Open-loop, RFC-A, RFC-S: -50000.0 to 0.0	
Range of [MAX]	Open-loop, RFC-A, RFC-S: 0.0 to 50000.0	
Definition	<p>This variable minimum/maximum defines the range of speed monitoring parameters. To allow headroom for overshoot the range is set to twice the range of the speed references.</p> <p>VM_SPEED[MAX] = 2 x VM_SPEED_FREQ_REF[MAX]</p> <p>VM_SPEED[MIN] = 2 x VM_SPEED_FREQ_REF[MIN]</p>	

VM_SPEED_FREQ_KEYPAD_REF		Range applied to the keypad reference															
Units	Open-loop: Hz RFC-A, RFC-S: rpm or mm/s																
Range of [MIN]	Open-loop: -599.0 to 599.0 RFC-A, RFC-S: -(550 x 60 / Motor pole pairs) to (550 x 60 / Motor pole pairs)																
Range of [MAX]	Open-loop: 0.0 to 599.0 RFC-A, RFC-S: 0.0 to 550 x 60 / Motor pole pairs																
Definition	<p>This variable maximum is applied to <i>Keypad Control Mode Reference</i> (01.017). The maximum applied to these parameters is the same as other frequency reference parameters.</p> <p>VM_SPEED_FREQ_USER_REFS [MAX] = VM_SPEED_FREQ_REF[MAX]</p> <p>However the minimum is dependent on <i>Negative Reference Clamp Enable</i> (01.008) and <i>Bipolar Reference Enable</i> (01.010).</p> <table border="1"> <thead> <tr> <th>Negative Reference Clamp Enable (01.008)</th> <th>Bipolar Reference Enable (01.010)</th> <th>VM_SPEED_FREQ_USER_REFS[MIN]</th> </tr> </thead> <tbody> <tr> <td>0</td> <td>0</td> <td>If <i>Select Motor 2 Parameters</i> (11.045) = 0 <i>Minimum Reference Clamp</i> (01.007), otherwise <i>M2 Minimum Reference Clamp</i> (21.002)</td> </tr> <tr> <td>0</td> <td>1</td> <td>-VM_SPEED_FREQ_REF[MAX]</td> </tr> <tr> <td>1</td> <td>0</td> <td>0.0</td> </tr> <tr> <td>1</td> <td>1</td> <td>-VM_SPEED_FREQ_REF[MAX]</td> </tr> </tbody> </table>		Negative Reference Clamp Enable (01.008)	Bipolar Reference Enable (01.010)	VM_SPEED_FREQ_USER_REFS[MIN]	0	0	If <i>Select Motor 2 Parameters</i> (11.045) = 0 <i>Minimum Reference Clamp</i> (01.007), otherwise <i>M2 Minimum Reference Clamp</i> (21.002)	0	1	-VM_SPEED_FREQ_REF[MAX]	1	0	0.0	1	1	-VM_SPEED_FREQ_REF[MAX]
Negative Reference Clamp Enable (01.008)	Bipolar Reference Enable (01.010)	VM_SPEED_FREQ_USER_REFS[MIN]															
0	0	If <i>Select Motor 2 Parameters</i> (11.045) = 0 <i>Minimum Reference Clamp</i> (01.007), otherwise <i>M2 Minimum Reference Clamp</i> (21.002)															
0	1	-VM_SPEED_FREQ_REF[MAX]															
1	0	0.0															
1	1	-VM_SPEED_FREQ_REF[MAX]															

VM_SPEED_FREQ_REF		Range applied to the frequency or speed reference parameters
Units	Open-loop: Hz RFC-A, RFC-S: rpm or mm/s	
Range of [MIN]	Open-loop: -599.0 to 0.0 RFC-A, RFC-S: -(550 x 60 / Motor pole pairs) to 0.0	
Range of [MAX]	Open-loop: 0.0 to 599.0 RFC-A, RFC-S: 0.0 to 550 x 60 / Motor pole pairs	
Definition	<p>If Pr 01.008 = 0: VM_SPEED_FREQ_REF[MAX] = Pr 01.006</p> <p>If Pr 01.008 = 1: VM_SPEED_FREQ_REF[MAX] = Pr 01.006 or Pr 01.007 , whichever is larger.</p> <p>If the second motor map is selected (Pr 11.045 = 1) Pr 21.001 is used instead of Pr 01.006 and Pr 21.002 instead of Pr 01.007.</p> <p>VM_SPEED_FREQ_REF[MIN] = -VM_SPEED_FREQ_REF[MAX].</p>	

VM_SPEED_FREQ_REF_UNIPOLAR		Unipolar version of VM_SPEED_FREQ_REF
Units	Open-loop: Hz RFC-A, RFC-S: rpm or mm/s	
Range of [MIN]	Open-loop: 0.0 RFC-A, RFC-S: 0.0	
Range of [MAX]	Open-loop: 0.0 to 599.0 RFC-A, RFC-S: 0.0 to 550 x 60 / Motor pole pairs	
Definition	VM_SPEED_FREQ_REF_UNIPOLAR[MAX] = VM_SPEED_FREQ_REF[MAX] VM_SPEED_FREQ_REF_UNIPOLAR[MIN] = 0.0	

VM_SPEED_FREQ_USER_REFS		Range applied to Analog reference parameters															
Units	Open-loop: Hz RFC-A, RFC-S: rpm or mm/s																
Range of [MIN]	Open-loop: -599.00 to 599.00 RFC-A, RFC-S: -(550 x 60 / Motor pole pairs) to 550 x 60 / Motor pole pairs																
Range of [MAX]	Open-loop: 0.00 to 599.00 RFC-A, RFC-S: 0.0 to 550 x 60 / Motor pole pairs																
Definition	VM_SPEED_FREQ_USER_REFS= VM_SPEED_FREQ_REF[MAX] <table border="1" style="width: 100%; margin-top: 10px;"> <thead> <tr> <th style="width: 33%;"><i>Negative Reference Clamp Enable (01.008)</i></th> <th style="width: 33%;"><i>Bipolar Reference Enable (01.010)</i></th> <th style="width: 33%;">VM_SPEED_FREQ_USER_REFS [MIN]</th> </tr> </thead> <tbody> <tr> <td style="text-align: center;">0</td> <td style="text-align: center;">0</td> <td>Pr 01.007</td> </tr> <tr> <td style="text-align: center;">0</td> <td style="text-align: center;">1</td> <td>-VM_SPEED_FREQ_REF[MAX]</td> </tr> <tr> <td style="text-align: center;">1</td> <td style="text-align: center;">0</td> <td>0.0</td> </tr> <tr> <td style="text-align: center;">1</td> <td style="text-align: center;">1</td> <td>-VM_SPEED_FREQ_REF[MAX]</td> </tr> </tbody> </table> If the second motor map is selected (Pr 11.045 = 1) Pr 21.002 is used instead of Pr 01.007 .		<i>Negative Reference Clamp Enable (01.008)</i>	<i>Bipolar Reference Enable (01.010)</i>	VM_SPEED_FREQ_USER_REFS [MIN]	0	0	Pr 01.007	0	1	-VM_SPEED_FREQ_REF[MAX]	1	0	0.0	1	1	-VM_SPEED_FREQ_REF[MAX]
<i>Negative Reference Clamp Enable (01.008)</i>	<i>Bipolar Reference Enable (01.010)</i>	VM_SPEED_FREQ_USER_REFS [MIN]															
0	0	Pr 01.007															
0	1	-VM_SPEED_FREQ_REF[MAX]															
1	0	0.0															
1	1	-VM_SPEED_FREQ_REF[MAX]															

VM_STD_UNDER_VOLTS		Range applied to the standard under-voltage threshold
Units	V	
Range of [MIN]	0 to 1150	
Range of [MAX]	0 to 1150	
Definition	VM_STD_UNDER_VOLTS[MAX] = VM_DC_VOLTAGE_SET / 1.1 VM_STD_UNDER_VOLTS[MIN] is voltage rating dependent. See Table 12-4	

VM_SUPPLY_LOSS_LEVEL		Range applied to the supply loss threshold
Units	V	
Range of [MIN]	0 to 1150	
Range of [MAX]	0 to 1150	
Definition	VM_SUPPLY_LOSS_LEVEL[MAX] = VM_DC_VOLTAGE_SET[MAX] VM_SUPPLY_LOSS_LEVEL[MIN] is drive voltage rating dependent. See Table 12-4	

VM_SWITCHING_FREQUENCY		Range applied to the maximum switching frequency parameters
Units	User units	
Range of [MIN]	0	
Range of [MAX]	0 to 6	
Definition	VM_SWITCHING_FREQUENCY[MAX] = Power stage dependent VM_SWITCHING_FREQUENCY[MIN] = 0 for motor control modes, or 1 for Regen mode (subject to the maximum)	

Safety information	Product information	Mechanical installation	Electrical installation	Getting started	Basic parameters	Running the motor	Optimization	Drive communication	NV Media Card Operation	Onboard PLC	Advanced parameters	Diagnostics	UL information
--------------------	---------------------	-------------------------	-------------------------	-----------------	------------------	-------------------	--------------	---------------------	-------------------------	-------------	---------------------	-------------	----------------

VM_TORQUE_CURRENT		Range applied to torque and torque producing current parameters (where this is used in Regen mode it refers to the active current)
Units	%	
Range of [MIN]	-1000.0 to 0.0	
Range of [MAX]	0.0 to 1000.0	
Definition	Select Motor 2 Parameters (11.045)	
	0	VM_MOTOR1_CURRENT_LIMIT[MAX]
	1	VM_MOTOR2_CURRENT_LIMIT[MAX]
VM_TORQUE_CURRENT[MIN] = -VM_TORQUE_CURRENT[MAX]		

VM_TORQUE_CURRENT_UNIPOLAR		Unipolar version of VM_TORQUE_CURRENT
Units	%	
Range of [MIN]	0.0	
Range of [MAX]	0.0 to 1000.0	
Definition	VM_TORQUE_CURRENT_UNIPOLAR[MAX] = VM_TORQUE_CURRENT[MAX] VM_TORQUE_CURRENT_UNIPOLAR[MIN] = 0.0	

VM_USER_CURRENT		Range applied to torque reference and percentage load parameters with one decimal place
Units	%	
Range of [MIN]	-1000.0 to 0.0	
Range of [MAX]	0.0 to 1000.0	
Definition	<p>VM_USER_CURRENT[MAX] = <i>User Current Maximum Scaling</i> (04.024)</p> <p>VM_USER_CURRENT[MIN] = -VM_USER_CURRENT[MAX]</p> <p><i>User Current Maximum Scaling</i> (04.024) defines the variable maximum/minimums VM_USER_CURRENT and VM_USER_CURRENT_HIGH_RES which are applied to <i>Percentage Load</i> (04.020), <i>Torque Reference</i> (04.008) and <i>Torque Offset</i> (04.009). This is useful when routing these parameters to an analog output as it allows the full scale output value to be defined by the user.</p> <p>The maximum value (VM_TORQUE_CURRENT_UNIPOLAR [MAX]) varies between drive sizes with default parameters loaded. For some drive sizes the default value may be reduced below the value given by the parameter range limiting.</p>	

VM_USER_CURRENT_HIGH_RES		Range applied to torque reference and percentage load parameters with two decimal places
Units	%	
Range of [MIN]	-1000.00 to 0.00	
Range of [MAX]	0.00 to 1000.00	
Definition	<p>VM_USER_CURRENT_HIGH_RES[MAX] = <i>User Current Maximum Scaling</i> (04.024) with an additional decimal place</p> <p>VM_USER_CURRENT_HIGH_RES[MIN] = -VM_USER_CURRENT_HIGH_RES[MAX]</p> <p><i>User Current Maximum Scaling</i> (04.024) defines the variable maximum/minimums VM_USER_CURRENT and VM_USER_CURRENT_HIGH_RES which are applied to <i>Percentage Load</i> (04.020), <i>Torque Reference</i> (04.008) and <i>Torque Offset</i> (04.009). This is useful when routing these parameters to an analog output as it allows the full scale output value to be defined by the user.</p> <p>The maximum value (VM_TORQUE_CURRENT_UNIPOLAR [MAX]) varies between drive sizes with default parameters loaded. For some drive sizes the default value may be reduced below the value given by the parameter range limiting.</p>	

Table 12-4 Voltage ratings dependant values

Variable min/max	Voltage level (V)			
	200 V	400 V	575 V	690 V
VM_DC_VOLTAGE_SET[MAX]	400	800	955	1150
VM_DC_VOLTAGE[MAX]	415	830	990	1190
VM_AC_VOLTAGE_SET[MAX]	265	530	635	765
VM_AC_VOLTAGE[MAX]	325	650	780	930
VM_STD_UNDER_VOLTS[MIN]	175	330	435	435
VM_SUPPLY_LOSS_LEVEL[MIN]	205	410	540	540
VM_HIGH_DC_VOLTAGE[MAX]	1500	1500	1500	1500

Safety information	Product information	Mechanical installation	Electrical installation	Getting started	Basic parameters	Running the motor	Optimization	Drive communication	NV Media Card Operation	Onboard PLC	Advanced parameters	Diagnostics	UL information
--------------------	---------------------	-------------------------	-------------------------	-----------------	------------------	-------------------	--------------	---------------------	-------------------------	-------------	----------------------------	-------------	----------------

12.2 Menu 1: Frequency / speed reference

Figure 12-1 Menu 1 logic diagram

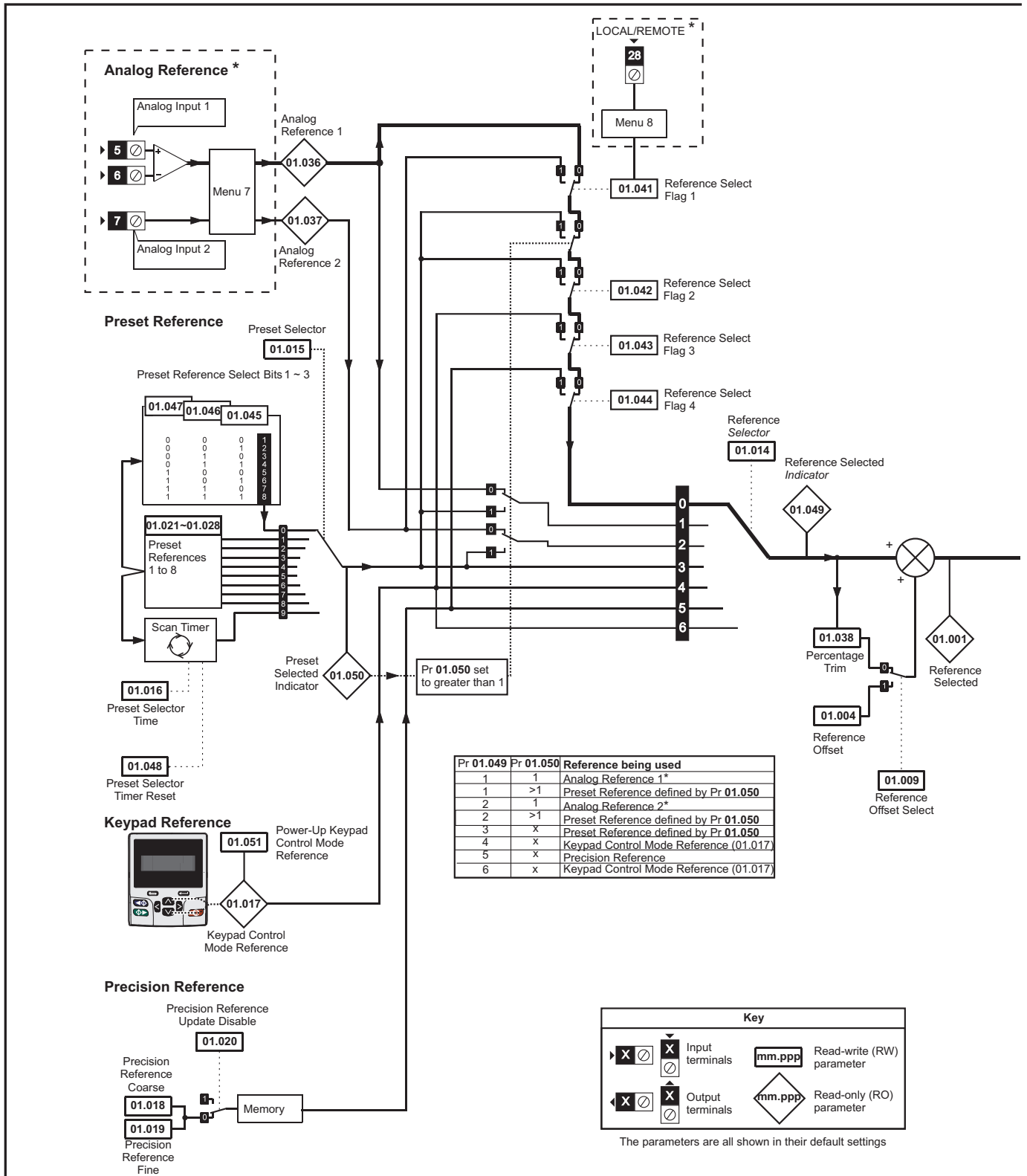

* Not available on Unidrive M702.

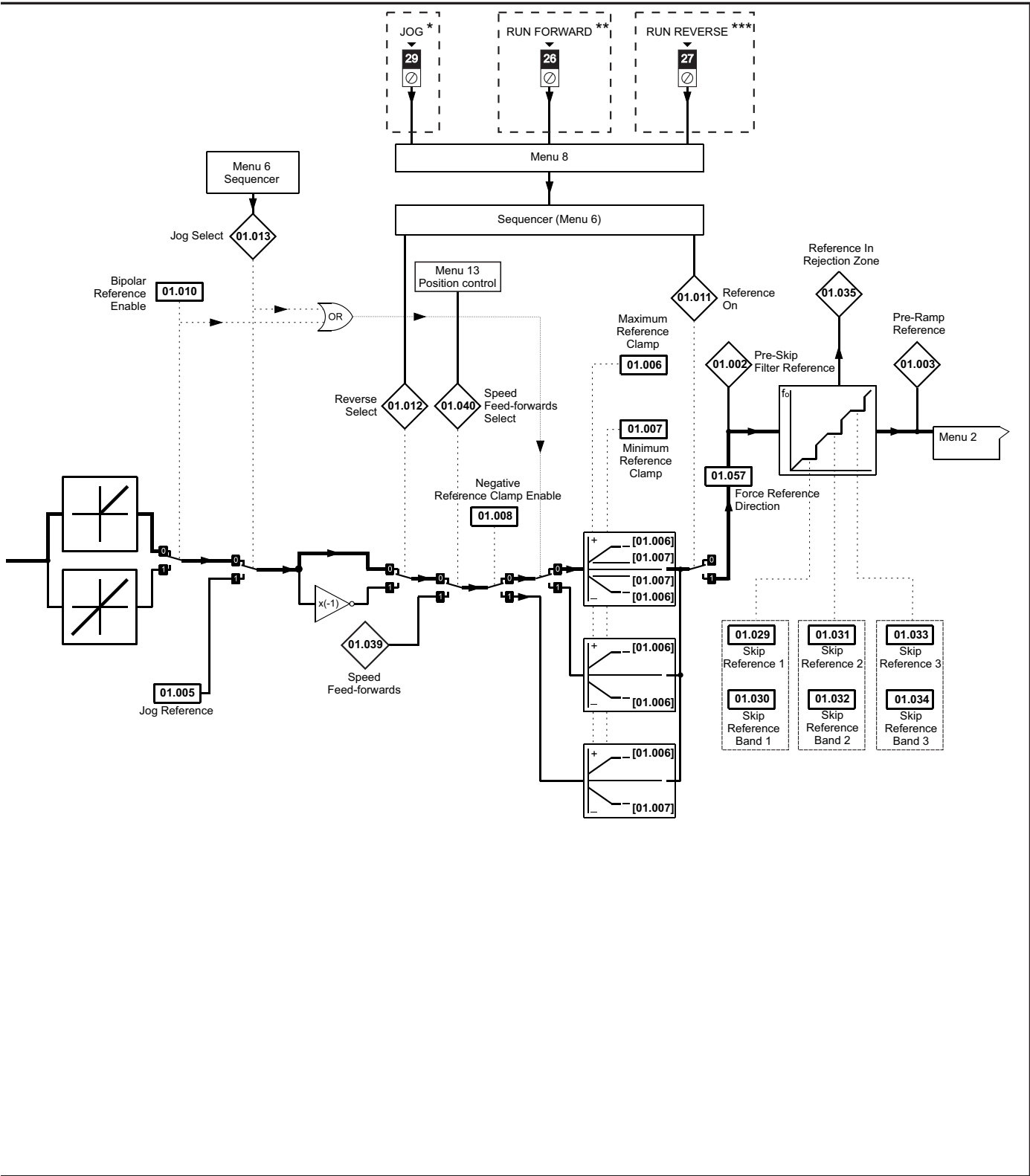

* Not available on Unidrive M702.

** Terminal 7 on Unidrive M702.

*** Terminal 8 on Unidrive M702.

Safety information	Product information	Mechanical installation	Electrical installation	Getting started	Basic parameters	Running the motor	Optimization	Drive communication	NV Media Card Operation	Onboard PLC	Advanced parameters	Diagnostics	UL information
--------------------	---------------------	-------------------------	-------------------------	-----------------	------------------	-------------------	--------------	---------------------	-------------------------	-------------	---------------------	-------------	----------------

Parameter	Range(φ)		Default(⇨)			Type								
	OL	RFC-A / S	OL	RFC-A	RFC-S									
01.001	Reference Selected	VM_SPEED_FREQ_REF Hz	VM_SPEED_FREQ_REF rpm				RO	Num	ND	NC	PT			
01.002	Pre-Skip Filter Reference	VM_SPEED_FREQ_REF Hz	VM_SPEED_FREQ_REF rpm				RO	Num	ND	NC	PT			
01.003	Pre-Ramp Reference	VM_SPEED_FREQ_REF Hz	VM_SPEED_FREQ_REF rpm				RO	Num	ND	NC	PT			
01.004	Reference Offset	VM_SPEED_FREQ_REF Hz	VM_SPEED_FREQ_REF rpm	0.0			RW	Num					US	
01.005	Jog Reference	0.0 to 400.0 Hz		0.0 to 4000.0 rpm		0.0			RW	Num				US
01.006	Maximum Reference Clamp	VM_POSITIVE_REF_CLAMP1 Hz	VM_POSITIVE_REF_CLAMP1 rpm	50 Hz: 50.0 60 Hz: 60.0	50Hz: 1500.0 60Hz: 1800.0	3000.0	RW	Num						US
01.007	Minimum Reference Clamp	VM_NEGATIVE_REF_CLAMP1 Hz	VM_NEGATIVE_REF_CLAMP1 rpm	0.0			RW	Num						US
01.008	Negative Reference Clamp Enable	Off (0) or On (1)		Off (0)			RW	Bit						US
01.009	Reference Offset Select	Off (0) or On (1)		Off (0)			RW	Bit						US
01.010	Bipolar Reference Enable	Off (0) or On (1)		Off (0)			RW	Bit						US
01.011	Reference On	Off (0) or On (1)					RO	Bit	ND	NC	PT			
01.012	Reverse Select	Off (0) or On (1)					RO	Bit	ND	NC	PT			
01.013	Jog Select	Off (0) or On (1)					RO	Bit	ND	NC	PT			
01.014	Reference Selector	A1 A2 (0)*, A1 Preset (1)*, A2 Preset (2)* Preset (3), Keypad (4), Precision (5) Keypad Ref (6)		A1 A2 (0)**			RW	Txt						US
01.015	Preset Selector	0 to 9		0			RW	Num						US
01.016	Preset Selector Time	0.0 to 400.0 s		10.0 s			RW	Num						US
01.017	Keypad Control Mode Reference	VM_SPEED_FREQ_KEYPAD_REF		0.0			RO	Num		NC	PT	PS		
01.018	Precision Reference Coarse	VM_SPEED_FREQ_REF		0.0			RW	Num						US
01.019	Precision Reference Fine	0.000 to 0.099 Hz	0.000 to 0.099 rpm	0.000			RW	Num						US
01.020	Precision Reference Update Disable	Off (0) or On (1)		Off (0)			RW	Bit			NC			US
01.021	Preset Reference 1	VM_SPEED_FREQ_REF		0.0			RW	Num						US
01.022	Preset Reference 2	VM_SPEED_FREQ_REF		0.0			RW	Num						US
01.023	Preset Reference 3	VM_SPEED_FREQ_REF		0.0			RW	Num						US
01.024	Preset Reference 4	VM_SPEED_FREQ_REF		0.0			RW	Num						US
01.025	Preset Reference 5	VM_SPEED_FREQ_REF		0.0			RW	Num						US
01.026	Preset Reference 6	VM_SPEED_FREQ_REF		0.0			RW	Num						US
01.027	Preset Reference 7	VM_SPEED_FREQ_REF		0.0			RW	Num						US
01.028	Preset Reference 8	VM_SPEED_FREQ_REF		0.0			RW	Num						US
01.029	Skip Reference 1	0.0 to 599.0 Hz	0 to 33, 000 rpm	0.0	0		RW	Num						US
01.030	Skip Reference Band 1	0.0 to 25.0 Hz	0 to 250 rpm	0.0	0		RW	Num						US
01.031	Skip Reference 2	0.0 to 599.0 Hz	0 to 33, 000 rpm	0.0	0		RW	Num						US
01.032	Skip Reference Band 2	0.0 to 25.0 Hz	0 to 250 rpm	0.0	0		RW	Num						US
01.033	Skip Reference 3	0.0 to 599.0 Hz	0 to 33, 000 rpm	0.0	0		RW	Num						US
01.034	Skip Reference Band 3	0.0 to 25.0 Hz	0 to 250 rpm	0.0	0		RW	Num						US
01.035	Reference In Rejection Zone	Off (0) or On (1)					RO	Bit	ND	NC	PT			
01.036	Analog Reference 1	VM_SPEED_FREQ_USER_REFS Hz	VM_SPEED_FREQ_USER_REFS rpm	0.0			RO	Num			NC			
01.037	Analog Reference 2			0.0			RO	Num			NC			
01.038	Percentage Trim	±100.00 %		0.00 %			RW	Num			NC			
01.039	Speed Feed-forwards	VM_SPEED_FREQ_REF					RO	Num	ND	NC	PT			
01.040	Speed Feed-forwards Select	Off (0) or On (1)					RO	Bit	ND	NC	PT			
01.041	Reference Select Flag 1	Off (0) or On (1)		Off (0)			RW	Bit			NC			
01.042	Reference Select Flag 2	Off (0) or On (1)		Off (0)			RW	Bit			NC			
01.043	Reference Select Flag 3	Off (0) or On (1)		Off (0)			RW	Bit			NC			
01.044	Reference Select Flag 4	Off (0) or On (1)		Off (0)			RW	Bit			NC			
01.045	Preset Select Flag 1	Off (0) or On (1)		Off (0)			RW	Bit			NC			
01.046	Preset Select Flag 2	Off (0) or On (1)		Off (0)			RW	Bit			NC			
01.047	Preset Select Flag 3	Off (0) or On (1)		Off (0)			RW	Bit			NC			
01.048	Preset Selector Timer Reset	Off (0) or On (1)		Off (0)			RW	Bit			NC			
01.049	Reference Selected Indicator	1 to 6					RO	Num	ND	NC	PT			
01.050	Preset Selected Indicator	1 to 8					RO	Num	ND	NC	PT			
01.051	Power-up Keypad Control Mode Reference	Reset (0), Last (1), Preset (2)		Reset (0)			RW	Txt						US
01.052	Hand/Off/Auto Operating Mode	0 to 3		0			RW	Num						US
01.055	Linear Speed Select			Off (0) or On (1)			RW	Bit						US
01.056	Linear Speed Selected			Off (0) or On (1)			RO	Bit	ND	NC	PT			
01.057	Force Reference Direction	None (0), Forward (1), Reverse (2)		None (0)			RW	Txt						US

* Not available on Unidrive M702.

** Preset (3) on Unidrive M702.

RW	Read / Write	RO	Read only	Num	Number parameter	Bit	Bit parameter	Txt	Text string	Bin	Binary parameter	FI	Filtered
ND	No default value	NC	Not copied	PT	Protected parameter	RA	Rating dependent	US	User save	PS	Power-down save	DE	Destination

Safety information	Product information	Mechanical installation	Electrical installation	Getting started	Basic parameters	Running the motor	Optimization	Drive communication	NV Media Card Operation	Onboard PLC	Advanced parameters	Diagnostics	UL information
--------------------	---------------------	-------------------------	-------------------------	-----------------	------------------	-------------------	--------------	---------------------	-------------------------	-------------	----------------------------	-------------	----------------

12.3 Menu 2: Ramps

Figure 12-2 Menu 2 logic diagram

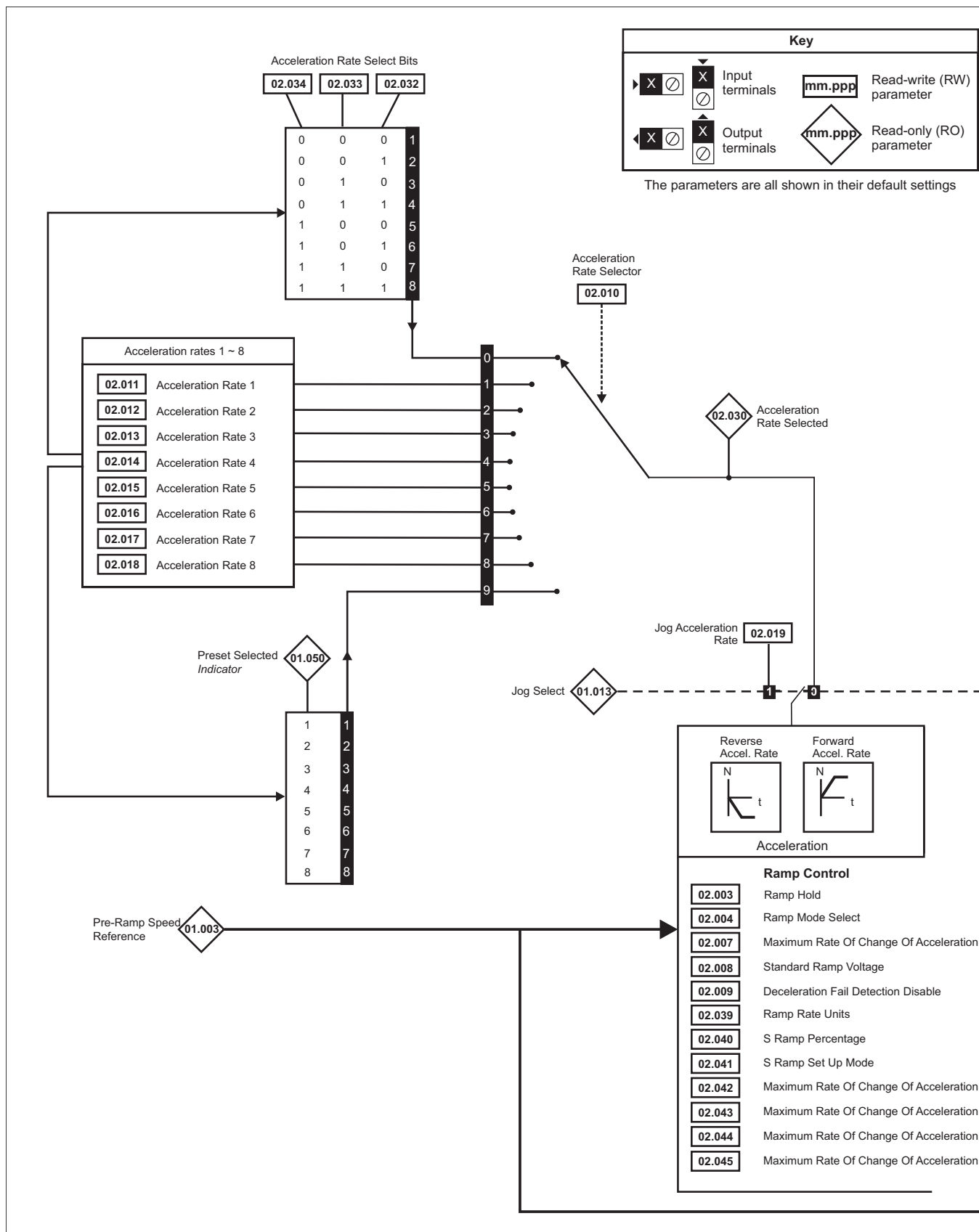

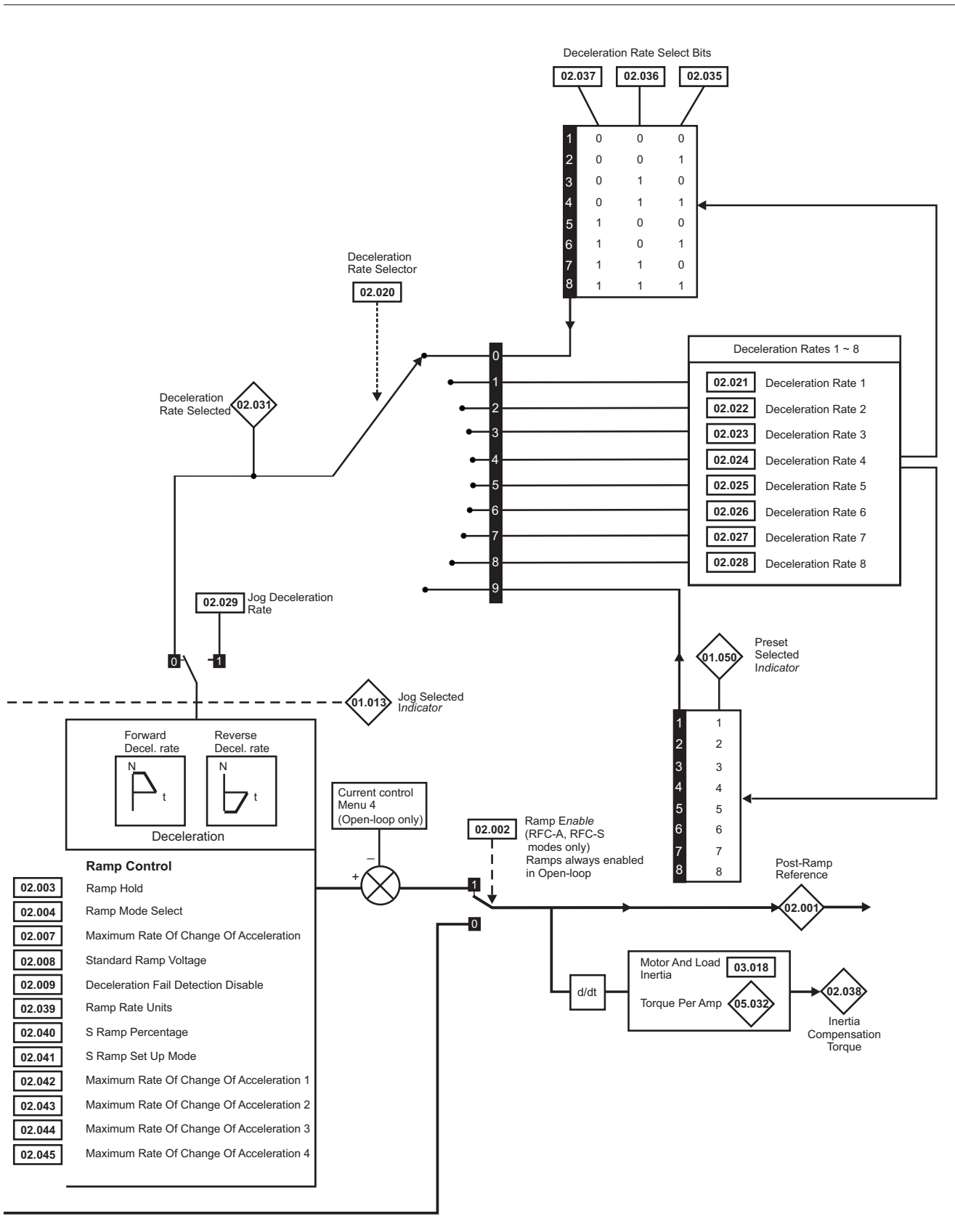

Safety information	Product information	Mechanical installation	Electrical installation	Getting started	Basic parameters	Running the motor	Optimization	Drive communication	NV Media Card Operation	Onboard PLC	Advanced parameters	Diagnostics	UL information
--------------------	---------------------	-------------------------	-------------------------	-----------------	------------------	-------------------	--------------	---------------------	-------------------------	-------------	---------------------	-------------	----------------

Parameter		Range(↕)		Default(⇒)			Type						
		OL	RFC-A / S	OL	RFC-A	RFC-S	RO	Num	ND	NC	PT		
02.001	Post Ramp Reference	VM_SPEED_FREQ_REF Hz	VM_SPEED_FREQ_REF rpm				RO	Num	ND	NC	PT		
02.002	Ramp Enable		Off (0) or On (1)			On (1)	RW	Bit					US
02.003	Ramp Hold		Off (0) or On (1)			Off (0)	RW	Bit					US
02.004	Ramp Mode	Fast (0), Standard (1), Std boost (2)	Fast (0), Standard (1)			Standard (1)	RW	Txt					US
02.005	Disable Ramp Output		Off (0) or On (1)			Off (0)	RW	Bit					US
02.006	S Ramp Enable		Off (0) or On (1)			Off (0)	RW	Bit					US
02.007	Maximum Rate Of Change Of Acceleration	0.0 to 300.0 s ² /100 Hz	0.000 to 100.000 s ² /1000 rpm	3.1	1.500	0.030	RW	Num					US
02.008	Standard Ramp Voltage	0 to VM_DC_VOLTAGE_SET V		200 V drive: 375 V 50 Hz - 400 V drive: 750 V 60 Hz - 400 V drive: 775 V 575 V drive: 895 V 690 V drive: 1075 V			RW	Num		RA			US
02.009	Deceleration Fail Detection Disable		Off (0) or On (1)			Off (0)	RW	Bit					US
02.010	Acceleration Rate Selector		0 to 9			0	RW	Num					US
02.011	Acceleration Rate 1	0.0 to VM_ACCEL_RATE s/100 Hz	0.000 to VM_ACCEL_RATE s/1000 rpm	5.0 s	2.000 s	0.200 s	RW	Num					US
02.012	Acceleration Rate 2	0.0 to VM_ACCEL_RATE s/100 Hz	0.000 to VM_ACCEL_RATE s/1000 rpm	5.0 s	2.000 s	0.200 s	RW	Num					US
02.013	Acceleration Rate 3	0.0 to VM_ACCEL_RATE s/100 Hz	0.000 to VM_ACCEL_RATE s/1000 rpm	5.0 s	2.000 s	0.200 s	RW	Num					US
02.014	Acceleration Rate 4	0.0 to VM_ACCEL_RATE s/100 Hz	0.000 to VM_ACCEL_RATE s/1000 rpm	5.0 s	2.000 s	0.200 s	RW	Num					US
02.015	Acceleration Rate 5	0.0 to VM_ACCEL_RATE s/100 Hz	0.000 to VM_ACCEL_RATE s/1000 rpm	5.0 s	2.000 s	0.200 s	RW	Num					US
02.016	Acceleration Rate 6	0.0 to VM_ACCEL_RATE s/100 Hz	0.000 to VM_ACCEL_RATE s/1000 rpm	5.0 s	2.000 s	0.200 s	RW	Num					US
02.017	Acceleration Rate 7	0.0 to VM_ACCEL_RATE s/100 Hz	0.000 to VM_ACCEL_RATE s/1000 rpm	5.0 s	2.000 s	0.200 s	RW	Num					US
02.018	Acceleration Rate 8	0.0 to VM_ACCEL_RATE s/100 Hz	0.000 to VM_ACCEL_RATE s/1000 rpm	5.0 s	2.000 s	0.200 s	RW	Num					US
02.019	Jog Acceleration Rate	0.0 to VM_ACCEL_RATE s/100 Hz	0.000 to VM_ACCEL_RATE s/1000 rpm	0.2 s	0.000 s		RW	Num					US
02.020	Deceleration Rate Selector		0 to 9			0	RW	Num					US
02.021	Deceleration Rate 1	0.0 to VM_ACCEL_RATE s/100 Hz	0.000 to VM_ACCEL_RATE s/1000 rpm	10.0 s	2.000 s	0.200 s	RW	Num					US
02.022	Deceleration Rate 2	0.0 to VM_ACCEL_RATE s/100 Hz	0.000 to VM_ACCEL_RATE s/1000 rpm	10.0 s	2.000 s	0.200 s	RW	Num					US
02.023	Deceleration Rate 3	0.0 to VM_ACCEL_RATE s/100 Hz	0.000 to VM_ACCEL_RATE s/1000 rpm	10.0 s	2.000 s	0.200 s	RW	Num					US
02.024	Deceleration Rate 4	0.0 to VM_ACCEL_RATE s/100 Hz	0.000 to VM_ACCEL_RATE s/1000 rpm	10.0 s	2.000 s	0.200 s	RW	Num					US
02.025	Deceleration Rate 5	0.0 to VM_ACCEL_RATE s/100 Hz	0.000 to VM_ACCEL_RATE s/1000 rpm	10.0 s	2.000 s	0.200 s	RW	Num					US
02.026	Deceleration Rate 6	0.0 to VM_ACCEL_RATE s/100 Hz	0.000 to VM_ACCEL_RATE s/1000 rpm	10.0 s	2.000 s	0.200 s	RW	Num					US
02.027	Deceleration Rate 7	0.0 to VM_ACCEL_RATE s/100 Hz	0.000 to VM_ACCEL_RATE s/1000 rpm	10.0 s	2.000 s	0.200 s	RW	Num					US
02.028	Deceleration Rate 8	0.0 to VM_ACCEL_RATE s/100 Hz	0.000 to VM_ACCEL_RATE s/1000 rpm	10.0 s	2.000 s	0.200 s	RW	Num					US
02.029	Jog Deceleration Rate	0.0 to VM_ACCEL_RATE s/100 Hz	0.000 to VM_ACCEL_RATE s/1000 rpm	0.2 s	0.000 s		RW	Num					US
02.030	Acceleration Rate Selected		0 to 8				RO	Num	ND	NC	PT		
02.031	Deceleration Rate Selected		0 to 8				RO	Num	ND	NC	PT		
02.032	Acceleration Rate Select Bit 0		Off (0) or On (1)			Off (0)	RW	Bit		NC			
02.033	Acceleration Rate Select Bit 1		Off (0) or On (1)			Off (0)	RW	Bit		NC			
02.034	Acceleration Rate Select Bit 2		Off (0) or On (1)			Off (0)	RW	Bit		NC			
02.035	Deceleration Rate Select Bit 0		Off (0) or On (1)			Off (0)	RW	Bit		NC			
02.036	Deceleration Rate Select Bit 1		Off (0) or On (1)			Off (0)	RW	Bit		NC			
02.037	Deceleration Rate Select Bit 2		Off (0) or On (1)			Off (0)	RW	Bit		NC			
02.038	Inertia Compensation Torque		±1000.0 %				RO	Num	ND	NC	PT		
02.039	Ramp Rate Units		Off (0) or On (1)			Off (0)	RW	Bit					US
02.040	S Ramp Percentage		0.0 to 50.0 %			0.0 %	RW						US
02.041	S Ramp Set-up Mode		Single (0), Percentage (1), Independent (2)			Single (0)	RW	Txt					US
02.042	Maximum Rate Of Change Of Acceleration 1	0.0 to 300.0	0.000 to 100.000	0.0	0.000		RW	Num					US
02.043	Maximum Rate Of Change Of Acceleration 2	0.0 to 300.0	0.000 to 100.000	0.0	0.000		RW	Num					US
02.044	Maximum Rate Of Change Of Acceleration 3	0.0 to 300.0	0.000 to 100.000	0.0	0.000		RW	Num					US
02.045	Maximum Rate Of Change Of Acceleration 4	0.0 to 300.0	0.000 to 100.000	0.0	0.000		RW	Num					US

RW	Read / Write	RO	Read only	Num	Number parameter	Bit	Bit parameter	Txt	Text string	Bin	Binary parameter	FI	Filtered
ND	No default value	NC	Not copied	PT	Protected parameter	RA	Rating dependent	US	User save	PS	Power-down save	DE	Destination

12.4 Menu 3: Frequency slaving, speed feedback and speed control

Figure 12-3 Menu 3 Open-loop logic diagram

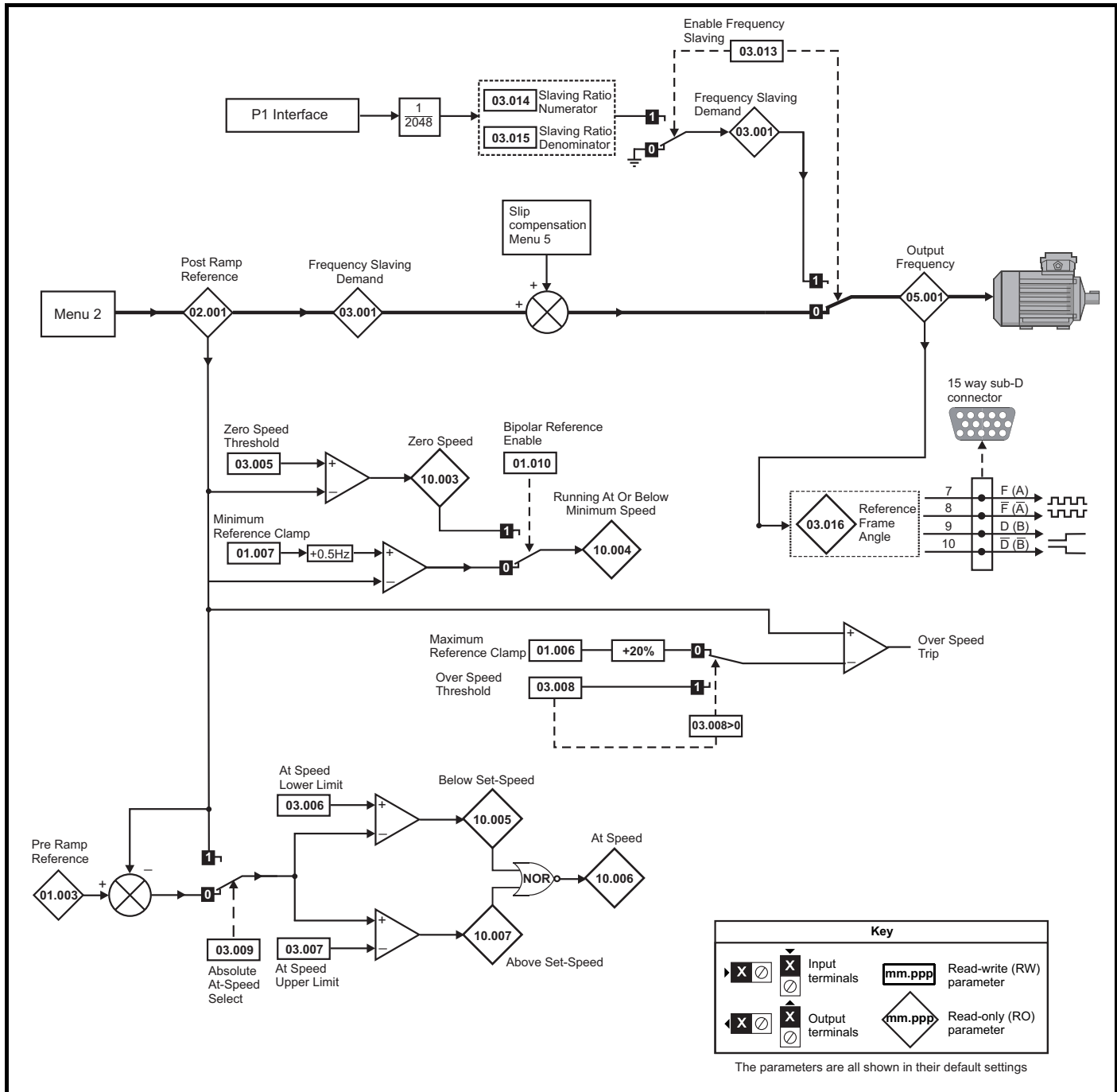
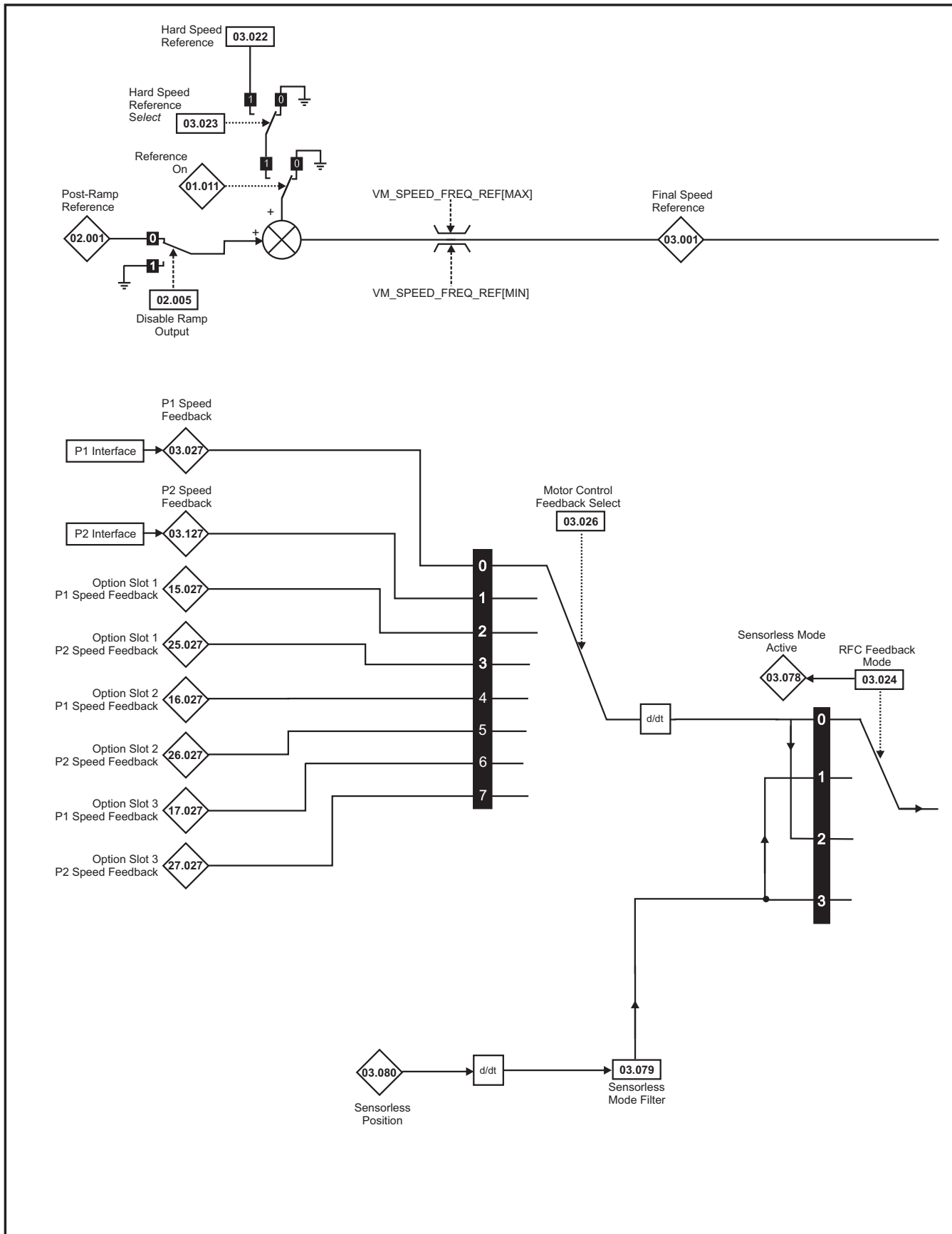

Figure 12-4 Menu 3 RFC-A, RFC-S logic diagram



NOTE

* Automatic change over if the relevant 'bit' of *Position Feedback Initialized* (03.076) is 0.

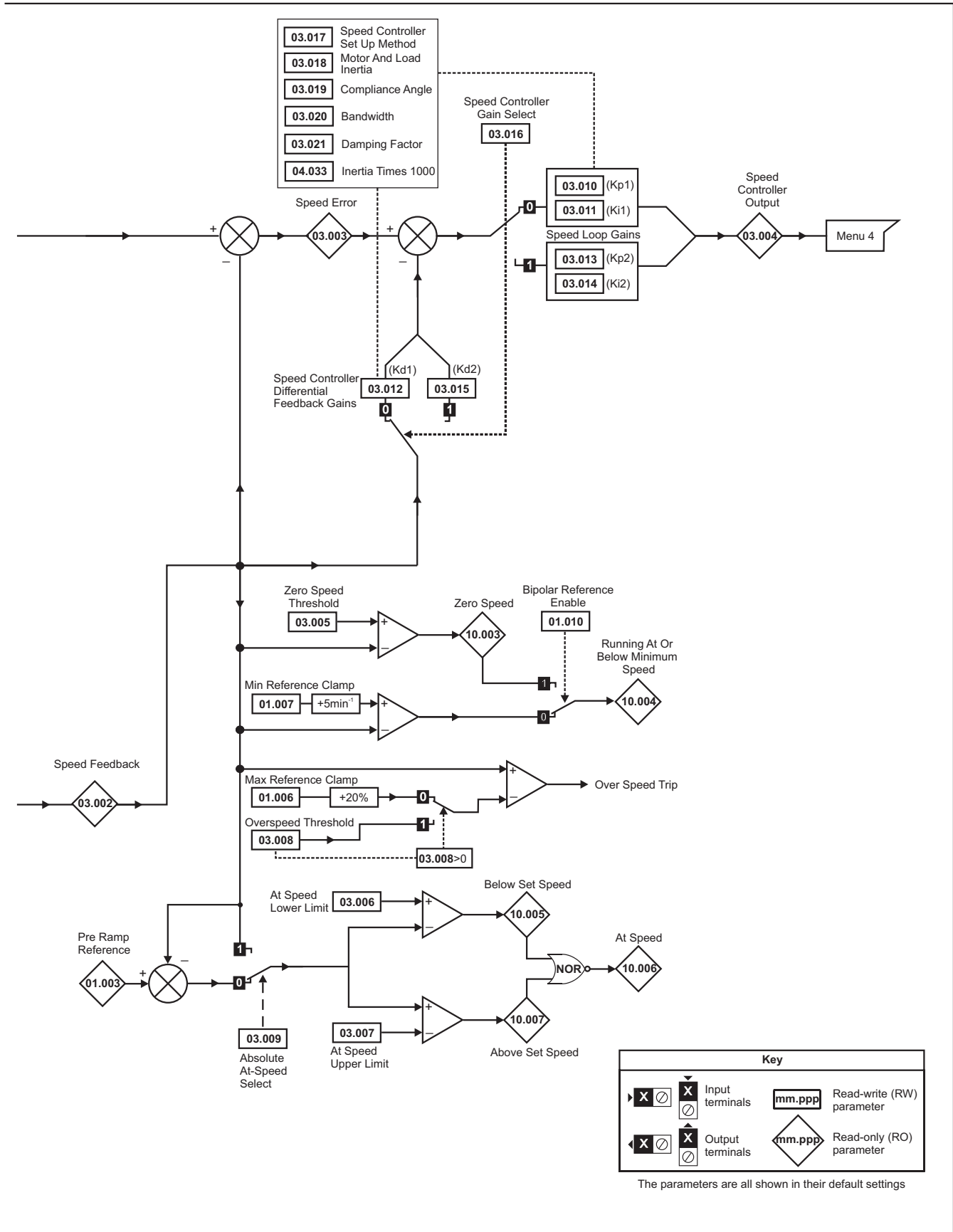

Figure 12-5 P1 Interface

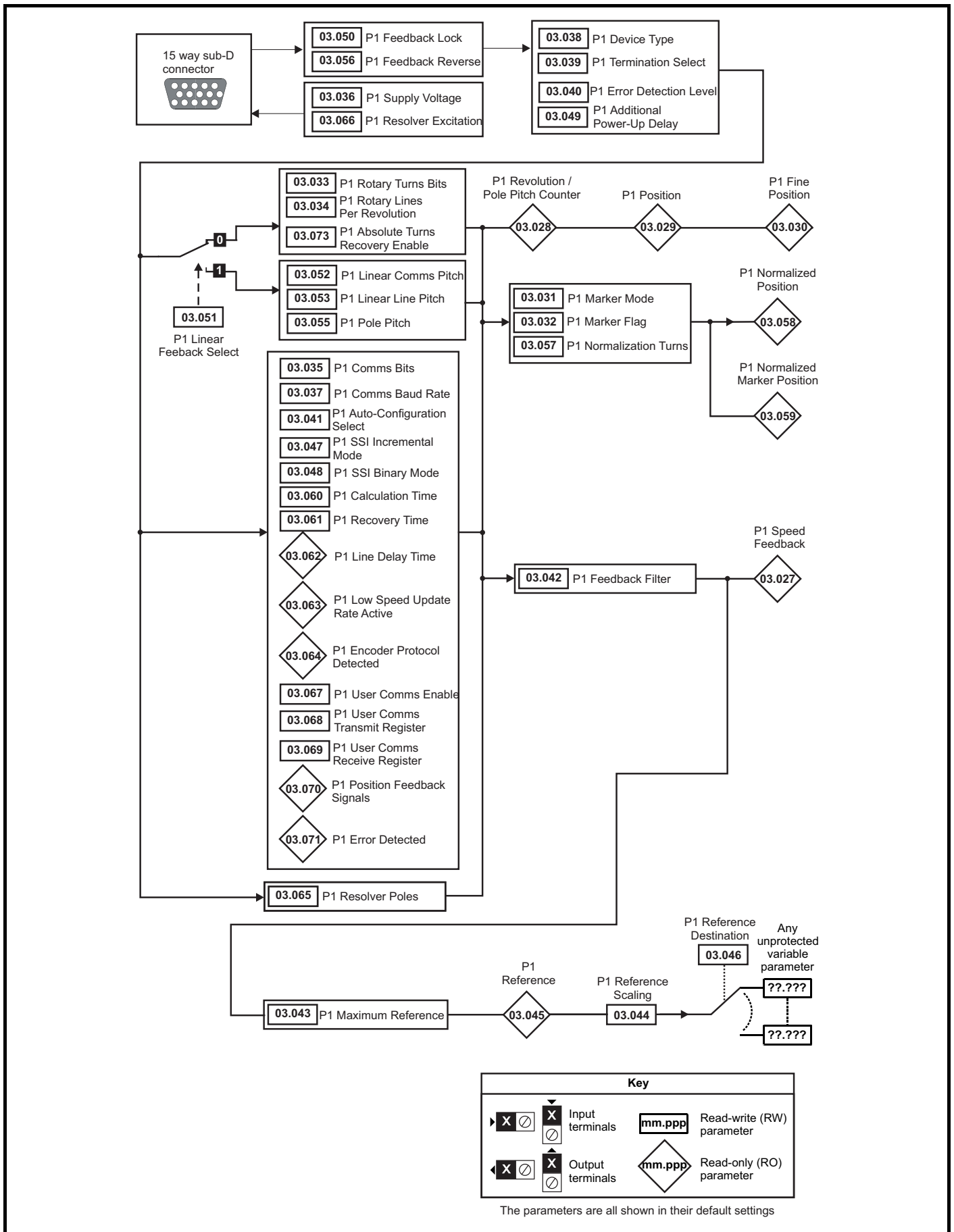

Figure 12-6 P2 Interface

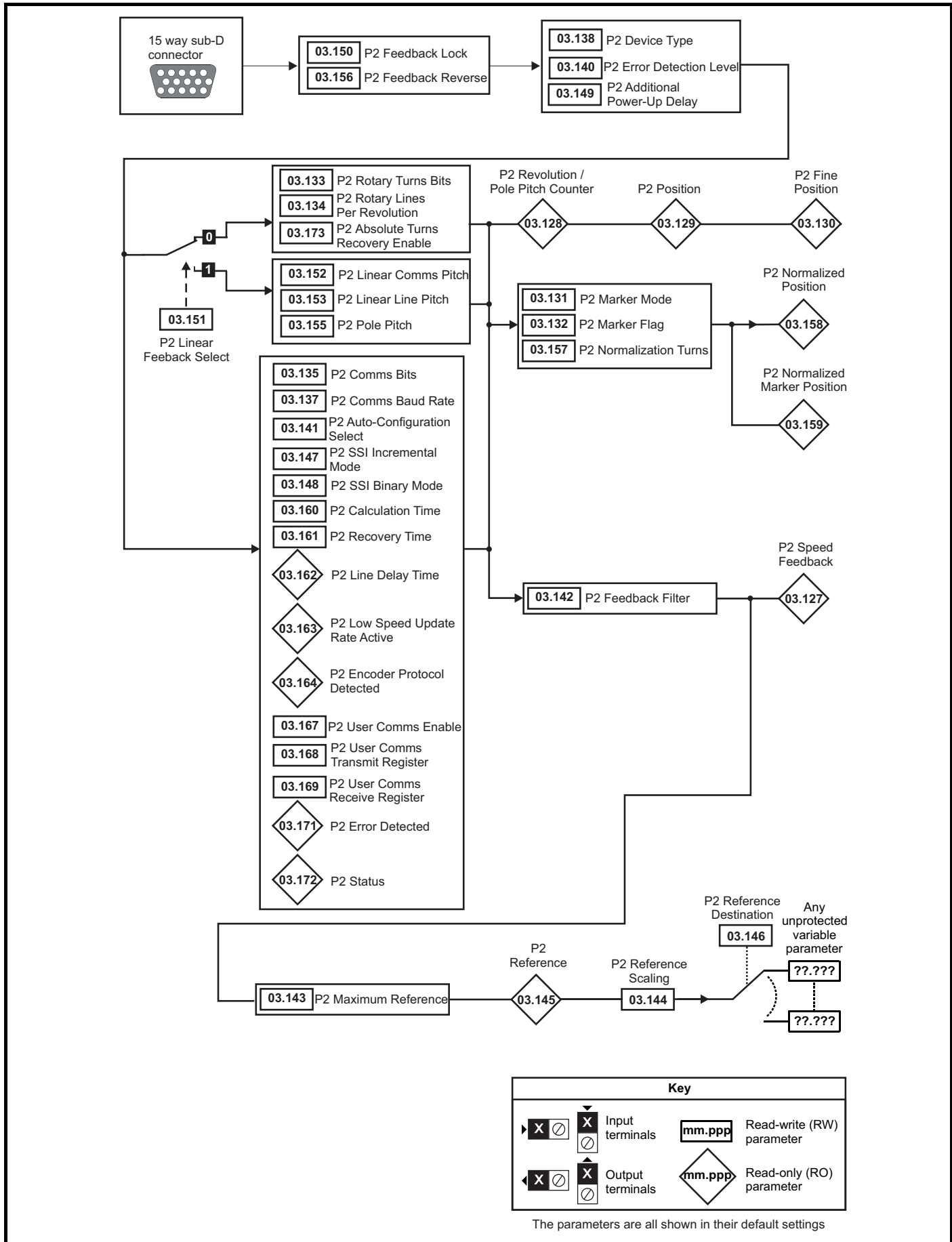

Figure 12-7 Freeze system logic

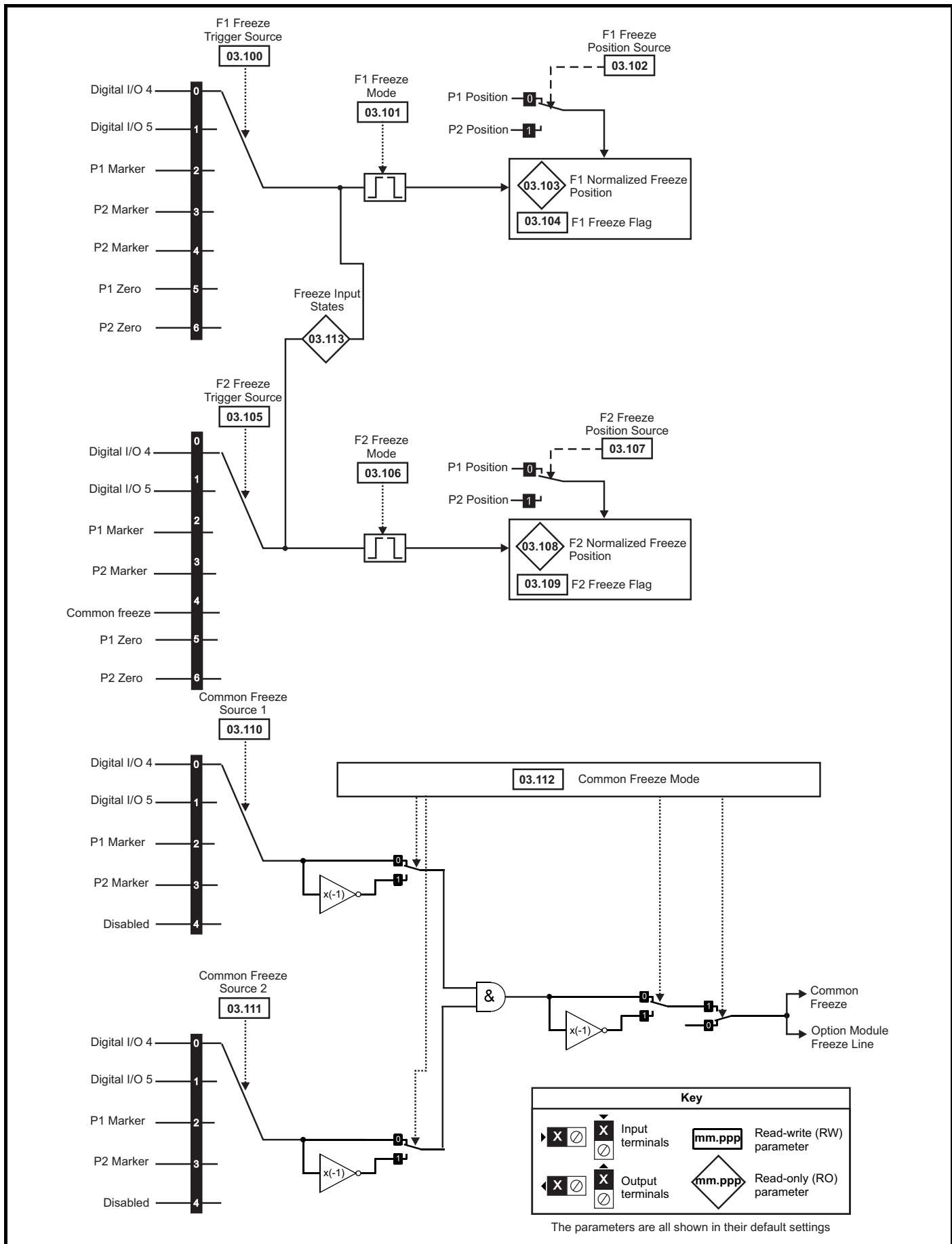

Figure 12-8 P1 Position feedback interface thermistor input

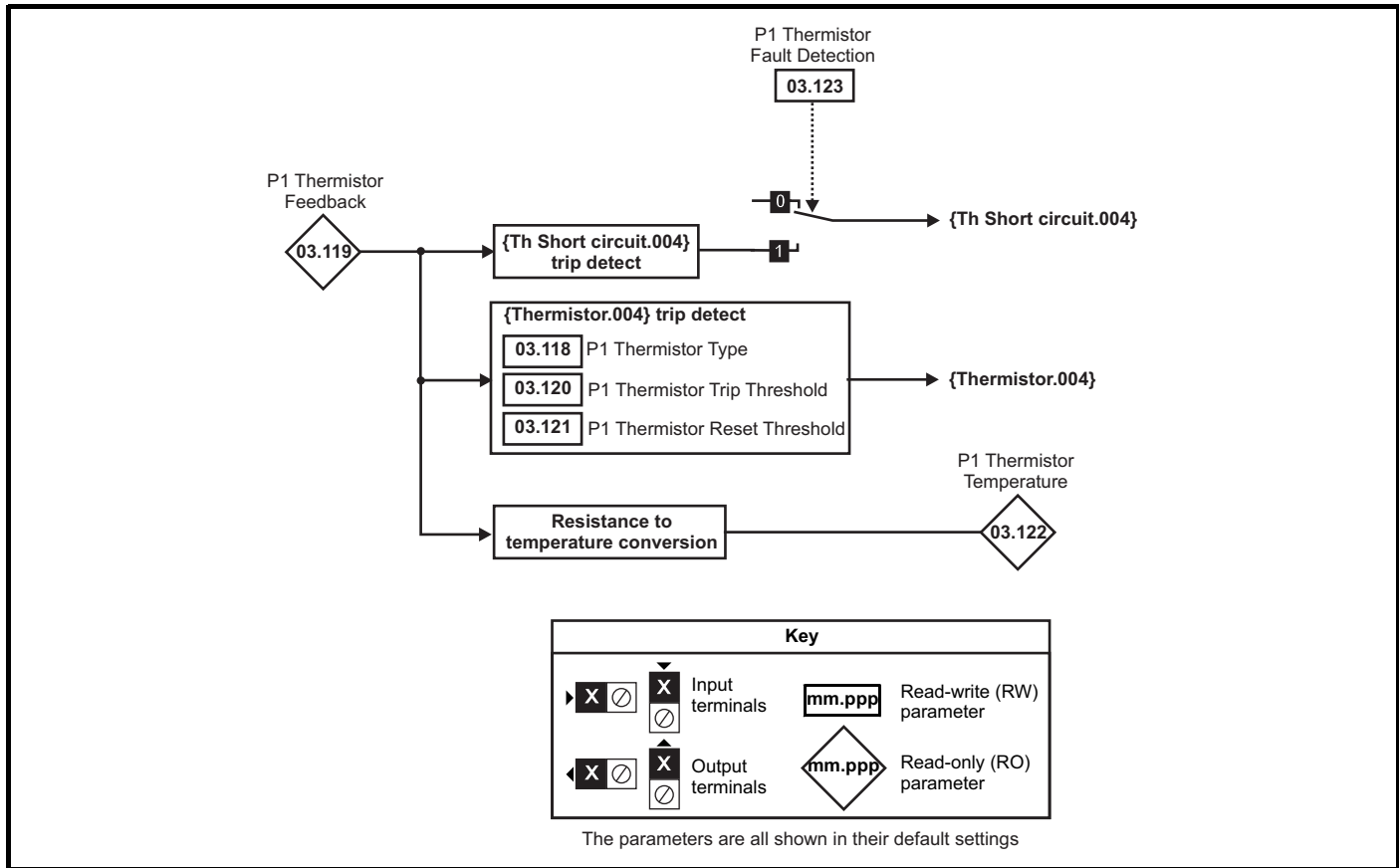
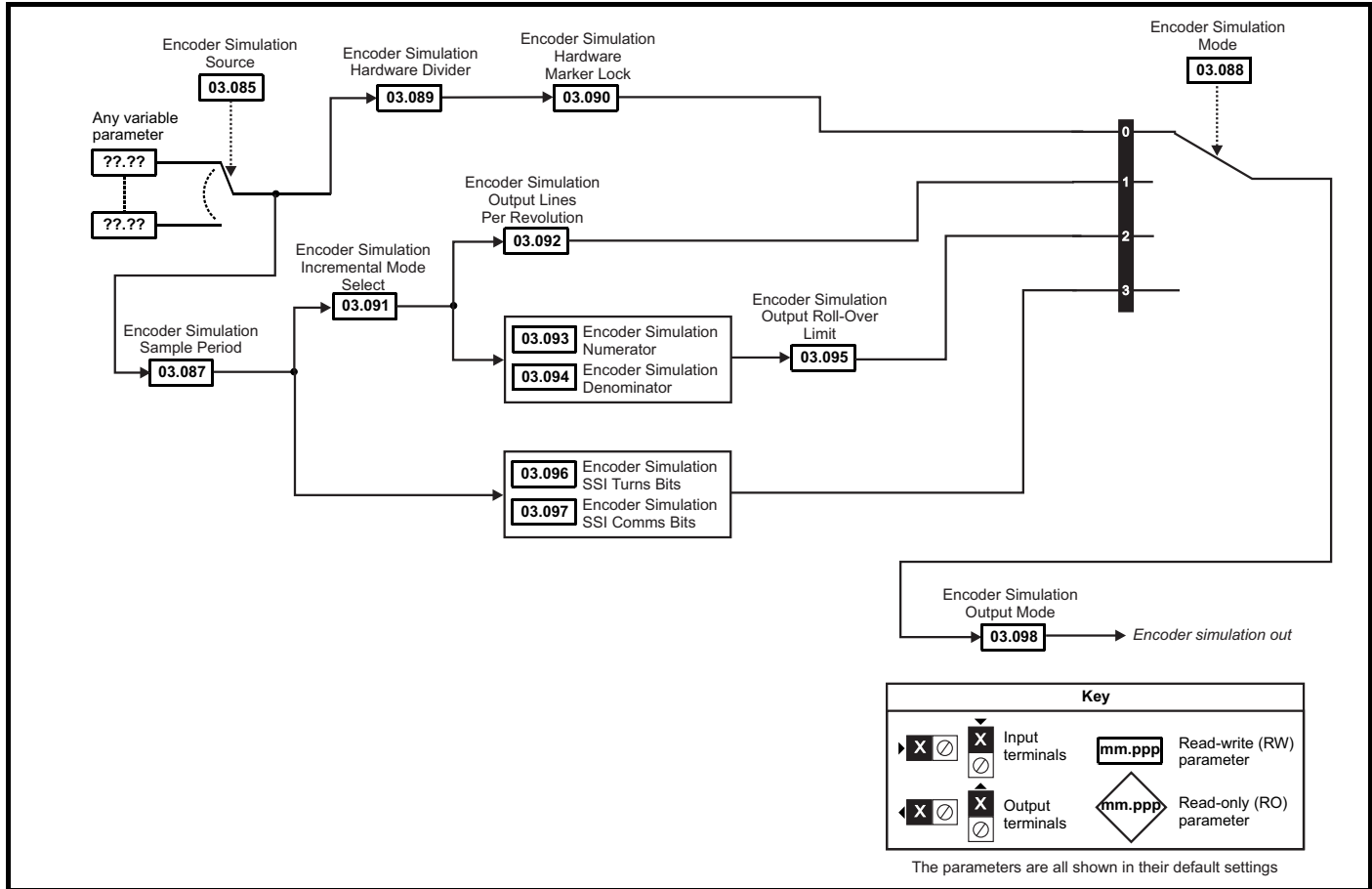

Figure 12-9 Encoder simulation



Safety information	Product information	Mechanical installation	Electrical installation	Getting started	Basic parameters	Running the motor	Optimization	Drive communication	NV Media Card Operation	Onboard PLC	Advanced parameters	Diagnostics	UL information
--------------------	---------------------	-------------------------	-------------------------	-----------------	------------------	-------------------	--------------	---------------------	-------------------------	-------------	---------------------	-------------	----------------

Parameter	Range			Default			Type					
	OL	RFC-A	RFC-S	OL	RFC-A	RFC-S						
03.001	Open-loop> Frequency Slaving Demand	±1000.0 Hz					RO	Num	ND	NC	PT	FI
	RFC> Final Speed Reference		VM_SPEED				RO	Num	ND	NC	PT	FI
03.002	Speed Feedback		VM_SPEED				RO	Num	ND	NC	PT	FI
03.003	Speed Error		VM_SPEED				RO	Num	ND	NC	PT	FI
03.004	Speed Controller Output		VM_TORQUE_CURRENT %				RO	Num	ND	NC	PT	FI
03.005	Zero Speed Threshold	0.0 to 20.0 Hz	0 to 200 rpm	1.0 Hz	5 rpm		RW	Num				US
03.006	At Speed Lower Limit	0.0 to 599.0 Hz	0 to 33,000 rpm	1.0 Hz	5 rpm		RW	Num				US
03.007	At Speed Upper Limit	0.0 to 599.0 Hz	0 to 33,000 rpm	1.0 Hz	5 rpm		RW	Num				US
03.008	Over Speed Threshold	0.0 to 599.0 Hz	0 to 33,000 rpm	0.0 Hz	0 rpm		RW	Num				US
03.009	Absolute At Speed Select		Off (0) or On (1)		Off (0)		RW	Bit				US
03.010	Speed Controller Proportional Gain Kp1		0.0000 to 200.0000 s/rad		0.0300 s/rad	0.0100 s/rad	RW	Num				US
03.011	Speed Controller Integral Gain Ki1		0.00 to 655.35 s ² /rad		0.10 s ² /rad	1.00 s ² /rad	RW	Num				US
03.012	Speed Controller Differential Feedback Gain Kd1		0.00000 to 0.65535 1/rad		0.00000	1/rad	RW	Num				US
03.013	Open-loop> Enable Frequency Slaving	Off (0) or On (1)		Off (0)			RW	Bit				US
	RFC> Speed Controller Proportional Gain Kp2		0.0000 to 200.0000 s/rad		0.0300 s/rad	0.0100 s/rad	RW	Num				US
03.014	Open-loop> Slaving Ratio Numerator	0.000 to 1.000		1.000			RW	Num				US
	RFC> Speed Controller Integral Gain Ki2		0.00 to 655.35 s ² /rad		0.10 s ² /rad	1.00 s ² /rad	RW	Num				US
03.015	Open-loop> Slaving Ratio Denominator	0.001 to 1.000		1.000			RW	Num				US
	RFC> Speed Controller Differential Feedback Gain Kd2		0.00000 to 0.65535 1/rad		0.00000	1/rad	RW	Num				US
03.016	Open-loop> Reference Frame Angle	0 to 65535					RO	Num	ND	NC	PT	
	RFC> Speed Controller Gain Select		Off (0) or On (1)		Off (0)		RW	Bit				US
03.017	Speed Controller Set-up Method		Disabled (0), Bandwidth (1), Comp Angle (2), Kp Gain Times 16 (3), Low Performance (4), Std Performance (5), High Performance (6), First Order (7)		Disabled (0)		RW	Txt				US
03.018	Motor And Load Inertia		0.00000 to 1000.00000 kgm ²		0.00000 kgm ²		RW	Num				US
03.019	Compliance Angle		0.0 to 360.0 °		4.0 °		RW	Num				US
03.020	Bandwidth		5 to 1000 Hz		10 Hz		RW	Num				US
03.021	Damping Factor		0.0 to 10.0		1.0		RW	Num				US
03.022	Hard Speed Reference		VM_SPEED_FREQ_REF		0.0		RW	Num				US
03.023	Hard Speed Reference Select		Off (0) or On (1)		Off (0)		RW	Bit				US
03.024	RFC Feedback Mode		Feedback (0), Sensorless (1), Feedback NoMax (2), Sensorless NoMax (3)		Feedback (0)		RW	Txt				US
03.025	Position Feedback Phase Angle			0.0 to 359.9 °		0.0 °	RW	Num	ND			US
03.026	Motor Control Feedback Select		P1 Drive (0), P2 Drive (1), P1 Slot 1 (2), P2 Slot 1 (3), P1 Slot 2 (4), P2 Slot 2 (5), P1 Slot 3 (6), P2 Slot 3 (7)		P1 Drive (0)		RW	Txt				US
03.027	P1 Speed Feedback		VM_SPEED				RO	Num	ND	NC	PT	FI
03.028	P1 Revolution/Pole Pitch Counter		0 to 65535				RO	Num	ND	NC	PT	PS
03.029	P1 Position		0 to 65535				RO	Num	ND	NC	PT	PS
03.030	P1 Fine Position		0 to 65535				RO	Num	ND	NC	PT	
03.031	P1 Marker Mode		0000 to 1111		0100		RW	Bin				US
03.032	P1 Marker Flag		Off (0) or On (1)		Off (0)		RW	Bit		NC		
03.033	P1 Rotary Turns Bits		0 to 16		16		RW	Num				US
03.034	P1 Rotary Lines Per Revolution		1 to 100000		1024	4096	RW	Num				US
03.035	P1 Comms Bits		0 to 48		0		RW	Num				US
03.036	P1 Supply Voltage		5V (0), 8V (1), 15V (2)		5V (0)		RW	Txt				US
03.037	P1 Comms Baud Rate		100k (0), 200k (1), 300k (2), 400k (3), 500k (4), 1M (5), 1.5M (6), 2M (7), 4M (8)		300k (2)		RW	Txt				US
03.038	P1 Device Type		AB (0), FD (1), FR (2), AB Servo (3), FD Servo (4), FR Servo (5), SC (6), SC Hiperface (7), EnDat (8), SC EnDat (9), SSI (10), SC SSI (11), SC Servo (12), BiSS (13), Resolver (14), SC SC (15), Commutation Only (16), SC BiSS (17), Option Slot 1 (18), Option Slot 2 (19), Option Slot 3 (20), Option Slot 4 (21)		AB (0)	AB Servo (3)	RW	Txt				US
03.039	P1 Termination Select		0 to 2		1		RW	Num				US
03.040	P1 Error Detection Level		00000000 to 11111111		00000000	00000001	RW	Bin				US
03.041	P1 Auto-configuration Select		Disabled (0) or Enabled (1)		Enabled (1)		RW	Txt				US

Safety information	Product information	Mechanical installation	Electrical installation	Getting started	Basic parameters	Running the motor	Optimization	Drive communication	NV Media Card Operation	Onboard PLC	Advanced parameters	Diagnostics	UL information
--------------------	---------------------	-------------------------	-------------------------	-----------------	------------------	-------------------	--------------	---------------------	-------------------------	-------------	---------------------	-------------	----------------

Parameter	Range			Default			Type						
	OL	RFC-A	RFC-S	OL	RFC-A	RFC-S							
03.042	P1 Feedback Filter	Disabled (0), 1 (1), 2 (2), 4 (3), 8 (4), 16 (5) ms			Disabled (0)			RW	Txt				US
03.043	P1 Maximum Reference	0 to 35,940 rpm	0 to 33,000 rpm		1500 rpm		3000 rpm	RW	Txt				US
03.044	P1 Reference Scaling	0.000 to 4.000			1.000			RW	Num				US
03.045	P1 Reference	±100.0 %						RO	Num	ND	NC	PT	FI
03.046	P1 Reference destination	0.000 to 59.999			0.000			RW	Num	DE		PT	US
03.047	P1 SSI Incremental Mode	Off (0) or On (1)			Off (0)			RW	Bit				US
03.048	P1 SSI Binary Mode	Off (0) or On (1)			Off (0)			RW	Bit				US
03.049	P1 Additional Power-up Delay	0.0 to 25.0 s			0.0 s			RW	Num				US
03.050	P1 Feedback Lock	Off (0) or On (1)			Off (0)			RW	Bit				US
03.051	P1 Linear Feedback Select	Off (0) or On (1)			Off (0)			RW	Bit				US
03.052	P1 Linear Comms Pitch	0.001 to 100.000			0.001			RW	Num				US
03.053	P1 Linear Line Pitch	0.001 to 100.000			0.001			RW	Num				US
03.054	P1 Linear Comms And Line Pitch Units	millimetres (0) or micrometres (1)			millimetres (0)			RW	Txt				US
03.055	P1 Pole Pitch	0.01 to 1000.00 mm			10.00 mm			RW	Num				US
03.056	P1 Feedback Reverse	Off (0) or On (1)			Off (0)			RW	Bit				US
03.057	P1 Normalization Turns	0 to 16			16			RW	Num				US
03.058	P1 Normalized Position	-2147483648 to 2147483647						RO	Num	ND	NC	PT	
03.059	P1 Normalized Marker Position	-2147483648 to 2147483647						RO	Num	ND	NC	PT	
03.060	P1 Calculation Time	0 to 20 µs			5 µs			RW	Num				US
03.061	P1 Recovery Time	5 to 100 µs			30 µs			RW	Num				US
03.062	P1 Line Delay Time	0 to 5000 ns						RO	Num	ND	NC	PT	US
03.063	P1 Low Speed Update Rate Active	Off (0) or On (1)						RO	Bit	ND	NC	PT	
03.064	P1 Encoder Protocol Detected	None (0), Hiperface (1), EnDat 2.1 (2), EnDat 2.2 (3), BiSS (4)						RO	Txt	ND	NC	PT	
03.065	P1 Resolver Poles	2 Poles (1) to 20 Poles (10)			2 Poles (1)			RW					US
03.066	P1 Resolver Excitation	6kHz 3V (0), 8kHz 3V (1), 6kHz 2V (2), 8kHz 2V (3), 6kHz 3V Fast (4), 8kHz 3V Fast (5), 6kHz 2V Fast (6), 8kHz 2V Fast (7)			6kHz 3V (0)			RW	Txt				US
03.067	P1 User Comms Enable	0 to 1			0			RW	Num		NC	PT	
03.068	P1 User Comms Transmit Register	0 to 65535			0			RW	Num		NC	PT	
03.069	P1 User Comms Receive Register	0 to 65535			0			RW	Num		NC	PT	
03.070	P1 Position Feedback Signals	000000 to 111111						RO	Bin	ND	NC	PT	
03.071	P1 Error Detected	Off (0) or On (1)						RO	Bit	ND	NC	PT	
03.073	P1 Absolute Turns Recovery Enable	Off (0) or On (1)			Off (0)			RW	Bit				US
03.074	P1 Additional Configuration	0 to 511116116			0			RW	Num				US
03.075	Initialise Position Feedback	Off (0) or On (1)			Off (0)			RW	Bit		NC		
03.076	Position Feedback Initialized	0000000000 to 1111111111			0000000000			RO	Bin		NC	PT	
03.078	Sensorless Mode Active	Off (0) or On (1)						RO	Bit	ND	NC	PT	
03.079	Sensorless Mode Filter	4 (0), 8 (1), 16 (2), 32 (3), 64 (4) ms			4 ms		64 ms	RW	Txt				US
03.080	Sensorless Position	-2147483648 to 2147483647						RO	Num	ND	NC	PT	
03.083	Full Motor Object Nameplate Transfer	Off (0) or On (1)			Off (0)			RW	Bit				US
03.085	Encoder Simulation Source	0.000 to 59.999			3.016		0.000	RW	Num			PT	US
03.086	Encoder Simulation Status	None (0), Full (1), No Marker Pulse (2)						RO	Txt	ND	NC	PT	
03.087	Encoder Simulation Sample Period	0.25 (0), 1 (1), 4, (2), 16 (3) ms			4 (2) ms		0.25 (0) ms	RW	Txt				US
03.088	Encoder Simulation Mode	Hardware (0), Lines Per Rev (1), Ratio (2), SSI (3)			Lines Per Rev (1)		Hardware (0)	RW	Txt				US
03.089	Encoder Simulation Hardware Divider	0 to 7			0			RW	Num				US
03.090	Encoder Simulation Hardware Marker Lock	Off (0) or On (1)			Off (0)			RW	Bit				US
03.091	Encoder Simulation Incremental Mode Select	Off (0) or On (1)			On (1)		Off (0)	RW	Bit				US
03.092	Encoder Simulation Output Lines Per Revolution	1 to 16384			1024		4096	RW	Num				US
03.093	Encoder Simulation Numerator	1 to 65536			65536			RW	Num				US
03.094	Encoder Simulation Denominator	1 to 65536			65536			RW	Num				US
03.095	Encoder Simulation Output Roll-over Limit	1 to 65535			65535			RW	Num				US
03.096	Encoder Simulation SSI Turns Bits	0 to 16			16			RW	Num				US
03.097	Encoder Simulation SSI Comms Bits	2 to 48			33			RW	Num				US
03.098	Encoder Simulation Output Mode	AB/Gray (0), FD/Binary (1), FR/Binary (2)			AB/Gray (0)			RW	Txt				US
03.100	F1 Freeze Trigger Source	Digital Input 4 (0), Digital Input 5 (1), P1 Marker (2), P2 Marker (3), Common (4), P1 Zero (5), P2 Zero (6)			Digital Input 4 (0)			RW	Txt				US
03.101	F1 Freeze Mode	Rising 1st (0), Falling 1st (1), Rising all (2), Falling all (3)			Rising 1st (0)			RW	Txt				US

Safety information	Product information	Mechanical installation	Electrical installation	Getting started	Basic parameters	Running the motor	Optimization	Drive communication	NV Media Card Operation	Onboard PLC	Advanced parameters	Diagnostics	UL information
--------------------	---------------------	-------------------------	-------------------------	-----------------	------------------	-------------------	--------------	---------------------	-------------------------	-------------	---------------------	-------------	----------------

Parameter	Range			Default			Type						
	OL	RFC-A	RFC-S	OL	RFC-A	RFC-S							
03.102	F1 Freeze Position Source	P1 (0), P2 (1), Time (2)			P1 (0)			RW	Txt				US
03.103	F1 Normalized Freeze Position	-2147483648 to 2147483647						RO	Num	ND	NC	PT	
03.104	F1 Freeze Flag	Off (0) or On (1)			Off (0)			RW	Bit	ND	NC	PT	
03.105	F2 Freeze Trigger Source	Digital Input 4 (0), Digital Input 5 (1), P1 Marker (2), P2 Marker (3), Common (4), P1 Zero (5), P2 Zero (6)			Digital Input 4 (0)			RW	Txt				US
03.106	F2 Freeze Mode	Rising 1st (0), Falling 1st (1), Rising all (2), Falling all (3)			Rising 1st (0)			RW	Txt				US
03.107	F2 Freeze Position Source	P1 (0), P2 (1), Time (2)			P1 (0)			RW	Txt				US
03.108	F2 Normalized Freeze Position	-2147483648 to 2147483647						RO	Num	ND	NC	PT	
03.109	F2 Freeze Flag	Off (0) or On (1)			Off (0)			RW	Bit	ND	NC	PT	
03.110	Common Freeze Source 1	Digital Input 4 (0), Digital Input 5 (1), P1 Marker (2), P2 Marker (3), Disabled (4)			Digital Input 4 (0)			RW	Txt				US
03.111	Common Freeze Source 2	Digital Input 4 (0), Digital Input 5 (1), P1 Marker (2), P2 Marker (3), Disabled (4)			Digital Input 4 (0)			RW	Txt				US
03.112	Common Freeze Mode	0000 to 1111			0000			RW	Bin				US
03.113	Freeze Input States	00 to 11						RO	Bin	ND	NC	PT	
03.118	P1 Thermistor Type	DIN44082 (0), KTY84 (1), 0.8mA (2), Encoder (3)			DIN44082 (0)			RW	Txt				US
03.119	P1 Thermistor Feedback	0 to 5000 Ω						RO	Num	ND	NC	PT	
03.120	P1 Thermistor Trip Threshold	0 to 5000 Ω			3300 Ω			RW	Num				US
03.121	P1 Thermistor Reset Threshold	0 to 5000 Ω			1800 Ω			RW	Num				US
03.122	P1 Thermistor Temperature	-50 to 300 °C						RO	Num	ND	NC	PT	
03.123	P1 Thermistor Fault Detection	None (0), Temperature (1), Temp or Short (2)			None (0)			RW	Txt				US
03.127	P2 Speed Feedback	±VM_SPEED						RO	Num	ND	NC	PT	FI
03.128	P2 Revolution/Pole Pitch Counter	0 to 65535						RO	Num	ND	NC	PT	PS
03.129	P2 Position	0 to 65535						RO	Num	ND	NC	PT	PS
03.130	P2 Fine Position	0 to 65535						RO	Num	ND	NC	PT	
03.131	P2 Marker Mode	0000 to 1111			0100			RW	Bin				US
03.132	P2 Marker Flag	Off (0) or On (1)			Off (0)			RW	Bit		NC		
03.133	P2 Rotary Turns Bits	0 to 16			16			RW	Num				US
03.134	P2 Rotary Lines Per Revolution	0 to 100000			1024		4096	RW	Num				US
03.135	P2 Comms Bits	0 to 48			0			RW	Num				US
03.137	P2 Comms Baud Rate	100k (0), 200k (1), 300k (2), 400k (3), 500k (4), 1M (5), 1.5M (6), 2M (7), 4M (8) Baud			300k (2) Baud			RW	Txt				US
03.138	P2 Device type	None (0), AB (1), FD (2), FR (3), EnDat (4), SSI (5), BiSS (6)			None (0)			RW	Txt				US
03.140	P2 Error Detection Level	00000 to 11111			00001			RW	Bin				US
03.141	P2 Auto-configuration Select	Disabled (0), Enabled (1)			Enabled (1)			RW	Txt				US
03.142	P2 Feedback Filter	Disabled (0), 1 (1), 2 (2), 4 (3), 8 (4), 16 (5) ms			Disabled (0)			RW	Txt				US
03.143	P2 Maximum Reference	0 to 35,940 rpm	0 to 33,000 rpm		1500 rpm		3000 rpm	RW	Txt				US
03.144	P2 Reference Scaling	0.000 to 4.000			1.000			RW	Num				US
03.145	P2 Reference	±100.0 %						RO	Num	ND	NC	PT	FI
03.146	P2 Reference Destination	0.000 to 59.999			0.000			RW	Num	DE		PT	US
03.147	P2 SSI Incremental Mode	Off (0) or On (1)			Off (0)			RW	Bit				US
03.148	P2 SSI Binary Mode	Off (0) or On (1)			Off (0)			RW	Bit				US
03.149	P2 Additional Power-up Delay	0.0 to 25.0 s			0.0 s			RW	Num				US
03.150	P2 Feedback Lock	Off (0) or On (1)			Off (0)			RW	Bit				US
03.151	P2 Linear Feedback Select	Off (0) or On (1)			Off (0)			RW	Bit				US
03.152	P2 Linear Comms Pitch	0.001 to 100.000			0.001			RW	Num				US
03.153	P2 Linear Line Pitch	0.001 to 100.000			0.001			RW	Num				US
03.154	P2 Linear Comms And Line Pitch Units	Millimetres (0) or Micrometres (1)			Millimetres (0)			RW	Txt				US
03.155	P2 Pole Pitch	0.01 to 1000.00 mm			10.00 mm			RW	Num				US
03.156	P2 Feedback Reverse	Off (0) or On (1)			Off (0)			RW	Bit				US
03.157	P2 Normalization Turns	0 to 16			16			RW	Num				US
03.158	P2 Normalized Position	-2147483648 to 2147483647						RO	Num	ND	NC	PT	
03.159	P2 Normalized Marker Position	-2147483648 to 2147483647						RO	Num	ND	NC	PT	
03.160	P2 Calculation Time	0 to 20 μs			5 μs			RW	Num				US

Safety information	Product information	Mechanical installation	Electrical installation	Getting started	Basic parameters	Running the motor	Optimization	Drive communication	NV Media Card Operation	Onboard PLC	Advanced parameters	Diagnostics	UL information
--------------------	---------------------	-------------------------	-------------------------	-----------------	------------------	-------------------	--------------	---------------------	-------------------------	-------------	---------------------	-------------	----------------

Parameter	Range			Default			Type						
	OL	RFC-A	RFC-S	OL	RFC-A	RFC-S	RW	Num	ND	NC	PT	US	
03.161	P2 Recovery Time	5 to 100 µs			30 µs			RW	Num				US
03.162	P2 Line Delay Time	0 to 5000 ns						RO	Num	ND	NC	PT	US
03.163	P2 Low Speed Update Rate Active	Off (0) or On (1)						RO	Bit	ND	NC	PT	
03.164	P2 Encoder Protocol Detected	None (0), Hiperface (1), EnDat 2.1 (2), EnDat 2.2 (3), BiSS (4)						RO	Txt	ND	NC	PT	
03.167	P2 User Comms Enable	0 to 1			0			RW	Num		NC	PT	
03.168	P2 User Comms Transmit Register	0 to 65535			0			RW	Num		NC	PT	
03.169	P2 User Comms Receive Register	0 to 65535			0			RW	Num		NC	PT	
03.171	P2 Error Detected	Off (0) or On (1)						RO	Bit	ND	NC	PT	
03.172	P2 Status	None (0), AB (1), FD (2), FR (3), EnDat (4), SSI (5), BiSS (6), EnDat Alt (7), SSI Alt (8), BiSS Alt (9)						RO	Txt	ND	NC	PT	
03.173	P2 Absolute Turns Recovery Enable	Off (0) or On (1)			Off (0)			RW	Bit				US
03.174	P2 Additional Configuration	0 to 511116116			0			RW	Num				US

RW	Read / Write	RO	Read only	Num	Number parameter	Bit	Bit parameter	Txt	Text string	Bin	Binary parameter	FI	Filtered
ND	No default value	NC	Not copied	PT	Protected parameter	RA	Rating dependent	US	User save	PS	Power-down save	DE	Destination

12.5 Menu 4: Torque and current control

Figure 12-10 Menu 4 Open loop logic diagram

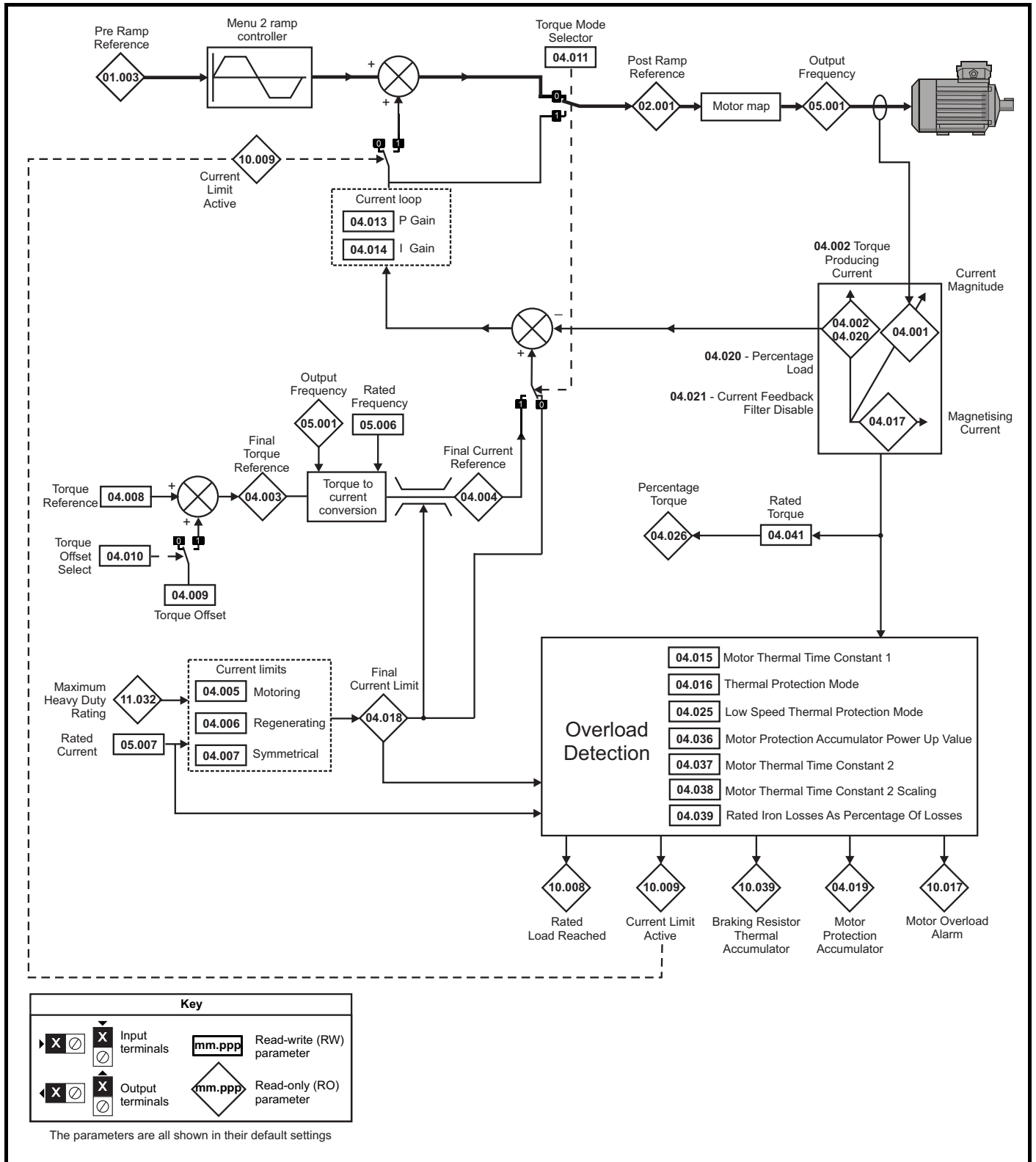

Figure 12-11 Menu 4 RFC-A logic diagram

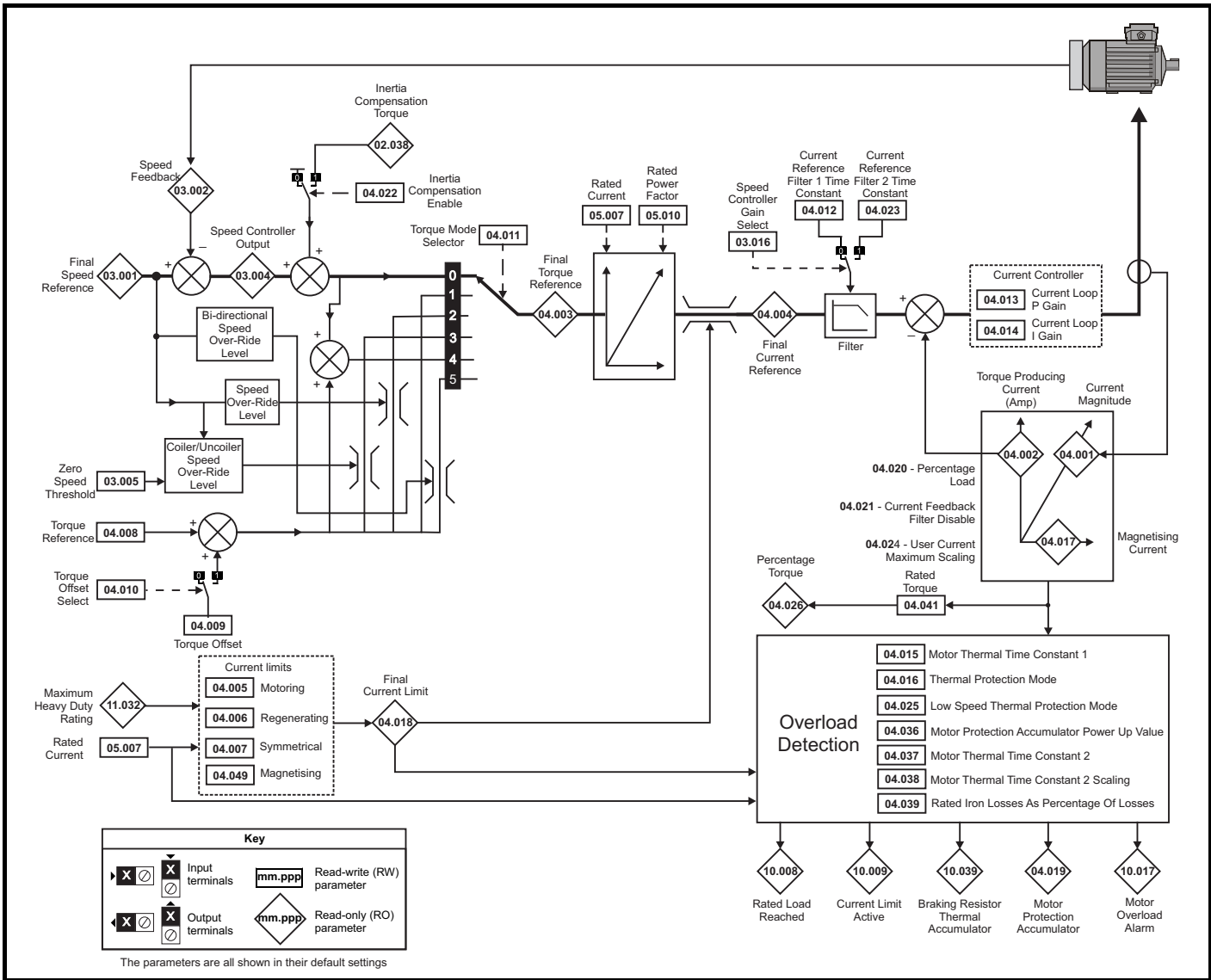
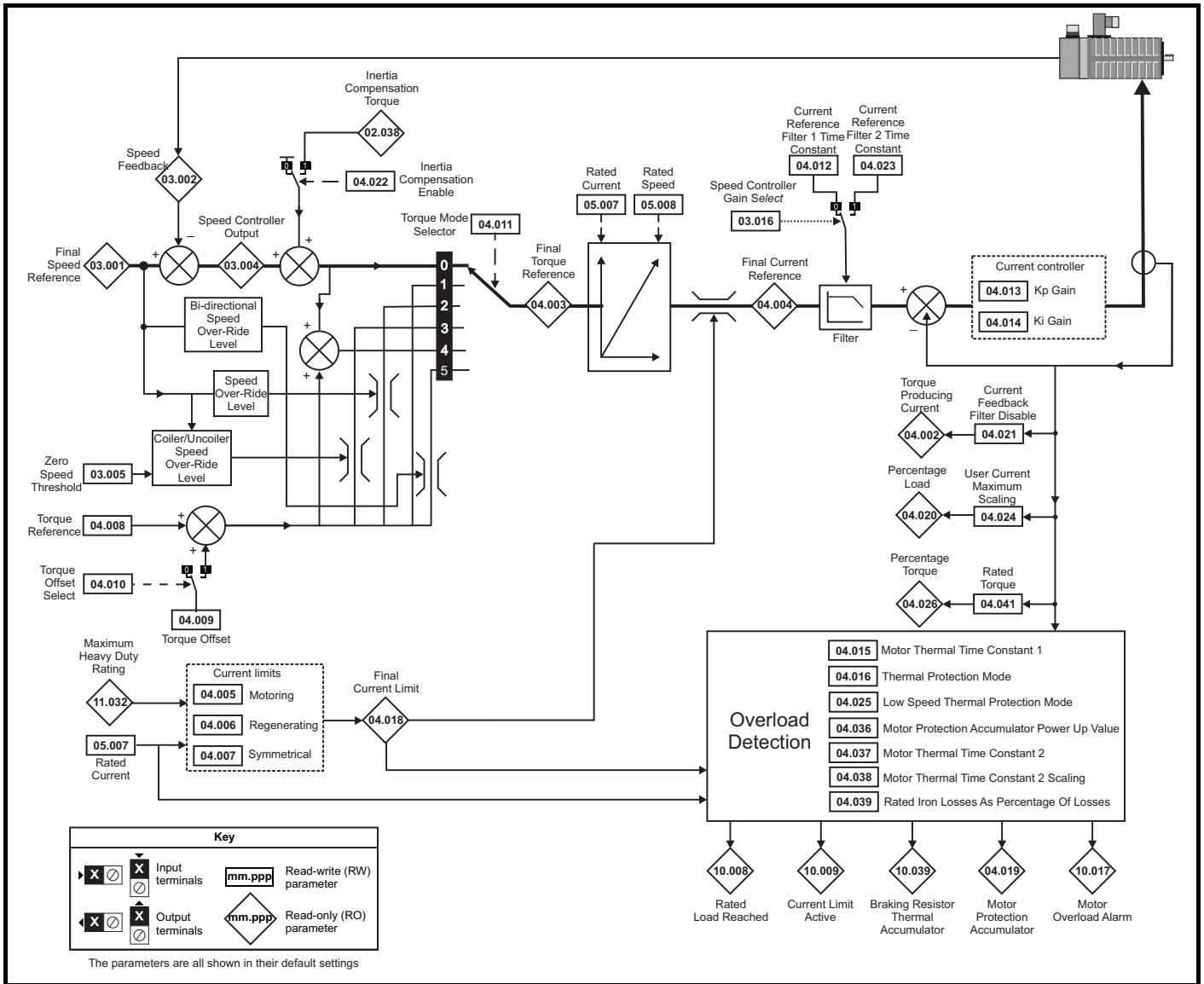

Figure 12-12 Menu 4 RFC-S logic diagram



Safety information	Product information	Mechanical installation	Electrical installation	Getting started	Basic parameters	Running the motor	Optimization	Drive communication	NV Media Card Operation	Onboard PLC	Advanced parameters	Diagnostics	UL information
--------------------	---------------------	-------------------------	-------------------------	-----------------	------------------	-------------------	--------------	---------------------	-------------------------	-------------	---------------------	-------------	----------------

Parameter	Range(⊕)		Default(⇨)			Type											
	OL	RFC-A / S	OL	RFC-A	RFC-S												
04.001	Current Magnitude	0.000 to VM_DRIVE_CURRENT_UNIPOLAR A										RO	Num	ND	NC	PT	FI
04.002	Torque Producing Current / Iq	VM_DRIVE_CURRENT A										RO	Num	ND	NC	PT	FI
04.003	Final Torque Reference	VM_TORQUE_CURRENT %										RO	Num	ND	NC	PT	FI
04.004	Final Current Reference	VM_TORQUE_CURRENT %										RO	Num	ND	NC	PT	FI
04.005	Motoring Current Limit	0.0 to VM_MOTOR1_CURRENT_LIMIT %		165.0 %*	175.0 %**							RW	Num		RA		US
04.006	Regenerating Current Limit	0.0 to VM_MOTOR1_CURRENT_LIMIT %		165.0 %*	175.0 %**							RW	Num		RA		US
04.007	Symmetrical Current Limit	0.0 to VM_MOTOR1_CURRENT_LIMIT %		165.0 %*	175.0 %**							RW	Num		RA		US
04.008	Torque Reference	VM_USER_CURRENT_HIGH_RES %		0.00 %								RW	Num				US
04.009	Torque Offset	VM_USER_CURRENT %		0.0 %								RW	Num				US
04.010	Torque Offset Select	Off (0) or On (1)		Off (0)								RW	Bit				US
04.011	Torque Mode Selector	0 to 1	0 to 5	0								RW	Num				US
04.012	Current Reference Filter 1 Time Constant	0.0 to 25.0 ms			0.0 ms							RW	Num				US
04.013	Current Controller Kp Gain	0 to 30000		20	150							RW	Num				US
04.014	Current Controller Ki Gain	0 to 30000		40	2000							RW	Num				US
04.015	Motor Thermal Time Constant 1	1.0 to 3000.0 s		89.0 s								RW	Num				US
04.016	Thermal Protection Mode	Motor Trip (0), Motor Limit (1), Drive Limit (2), Both Limit (3), Disabled (4)		Motor Trip (0)								RW	Bin				US
04.017	Magnetising Current / Id	VM_DRIVE_CURRENT A										RO	Num	ND	NC	PT	FI
04.018	Final Current Limit	VM_TORQUE_CURRENT %										RO	Num	ND	NC	PT	
04.019	Motor Protection Accumulator	0.0 to 100.0 %	0.0 to 200.0 %									RO	Num	ND	NC	PT	PS
04.020	Percentage Load	VM_USER_CURRENT %										RO	Num	ND	NC	PT	FI
04.021	Current Feedback Filter Disable	Off (0) or On (1)		Off (0)								RW	Bit				US
04.022	Inertia Compensation Enable		Off (0) or On (1)		Off (0)							RW	Bit				US
04.023	Current Reference Filter 2 Time Constant	0.0 to 25.0 ms			0.0 ms							RW	Num				US
04.024	User Current Maximum Scaling	0.0 to VM_TORQUE_CURRENT_UNIPOLAR %		165.0 %*	175.0 %**							RW	Num		RA		US
04.025	Low Speed Thermal Protection Mode	0 to 1		0								RW	Num				US
04.026	Percentage Torque	VM_USER_CURRENT %										RO	Num	ND	NC	PT	FI
04.027	Low Load Detection Level	0.0 to 100.0 %		0.0 %								RW	Num				US
04.028	Low Load Detection Speed/Frequency Threshold	0.0 to VM_SPEED_FREQ_REF_UNIPOLAR		0.0								RW	Num				US
04.029	Enable Trip On Low Load	Off (0) or On (1)		Off (0)								RW	Bit				US
04.030	Current Controller Mode		Off (0) or On (1)		Off (0)							RW	Bit				US
04.031	Notch Filter Centre Frequency	50 to 1000 Hz			100 Hz							RW	Num				US
04.032	Notch Filter Bandwidth	0 to 500 Hz			0 Hz							RW	Num				US
04.033	Inertia Times 1000		Off (0) or On (1)		Off (0)							RW	Bit				US
04.036	Motor Protection Accumulator Power-up Value	Power down (0), Zero (1), Real time (2)		Power down (0)								RW	Txt				US
04.037	Motor Thermal Time Constant 2	1.0 to 3000.0 s		89.0 s								RW	Num				US
04.038	Motor Thermal Time Constant 2 Scaling	0 to 100 %		0 %								RW	Num				US
04.039	Rated Iron Losses As Percentage Of Losses	0 to 100 %		0 %								RW	Num				US
04.041	Rated Torque	0.00 to 50000.00 N m		0.00 N m								RW	Num				US
04.042	Torque Estimation Minimum Frequency	0 to 100 %		5 %								RW	Num				US
04.043	Torque Correction Time Constant		0.00 to 10.00 s		0.00 s							RW	Num				US
04.044	Torque Correction Maximum		0 to 100 %		20 %							RW	Num				US
04.045	No-load Core Loss	0.000 to 99999.999 kW		0.000 kW								RW	Num				US
04.046	Rated Core Loss	0.000 to 99999.999 kW		0.000 kW								RW	Num				US
04.049	Magnetising Current Limit		0.0 to 100.0 %		100.0 %							RW	Num				US

* For size 9 and above the default is 141.9 %.

** For size 9 and above the default is 150.0 %.

RW	Read / Write	RO	Read only	Num	Number parameter	Bit	Bit parameter	Txt	Text string	Bin	Binary parameter	FI	Filtered
ND	No default value	NC	Not copied	PT	Protected parameter	RA	Rating dependent	US	User save	PS	Power-down save	DE	Destination

12.6 Menu 5: Motor control

Figure 12-13 Menu 5 Open-loop logic diagram

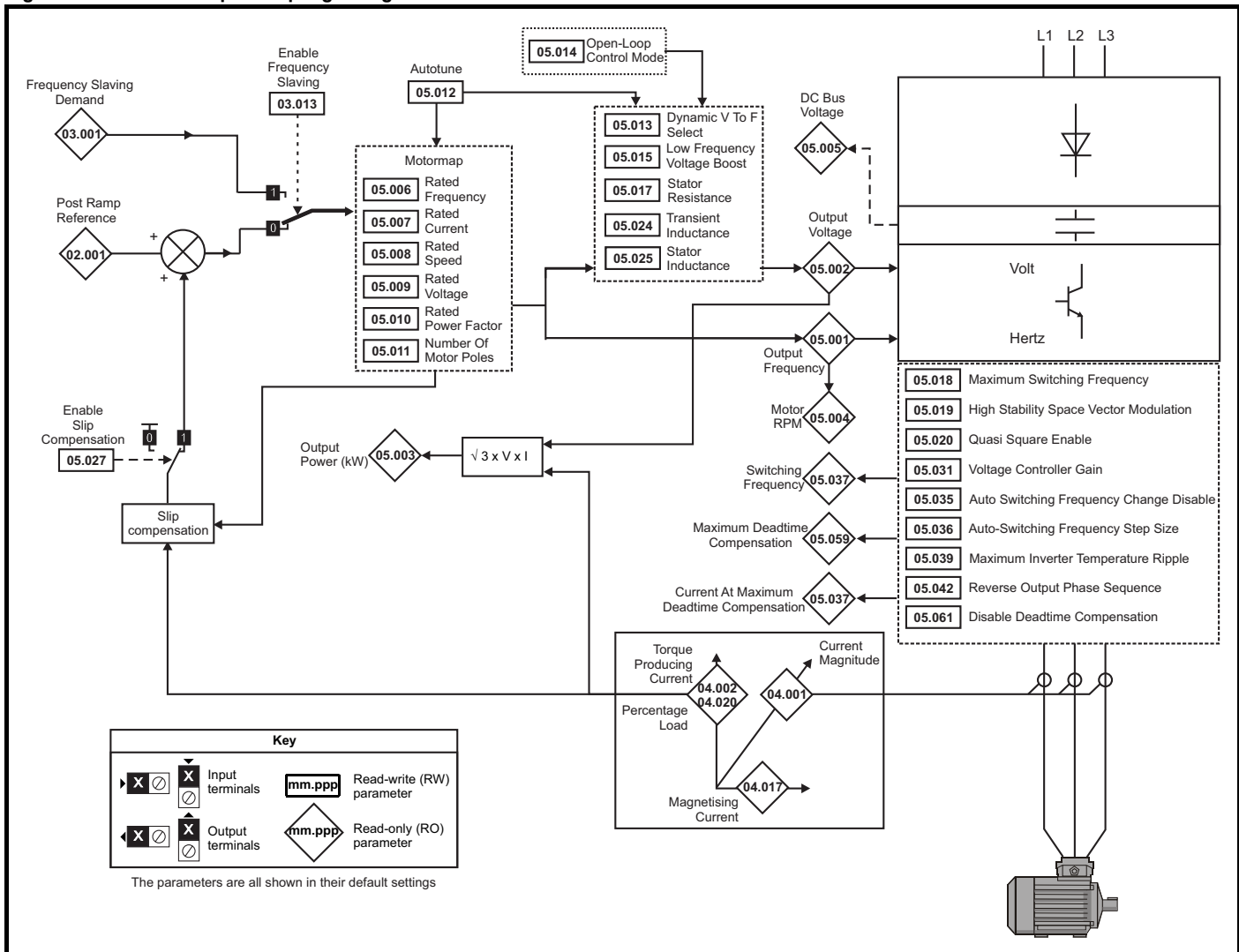

Safety information	Product information	Mechanical installation	Electrical installation	Getting started	Basic parameters	Running the motor	Optimization	Drive communication	NV Media Card Operation	Onboard PLC	Advanced parameters	Diagnostics	UL information
--------------------	---------------------	-------------------------	-------------------------	-----------------	------------------	-------------------	--------------	---------------------	-------------------------	-------------	----------------------------	-------------	----------------

Figure 12-14 Menu 5 RFC-A, RFC-S logic diagram

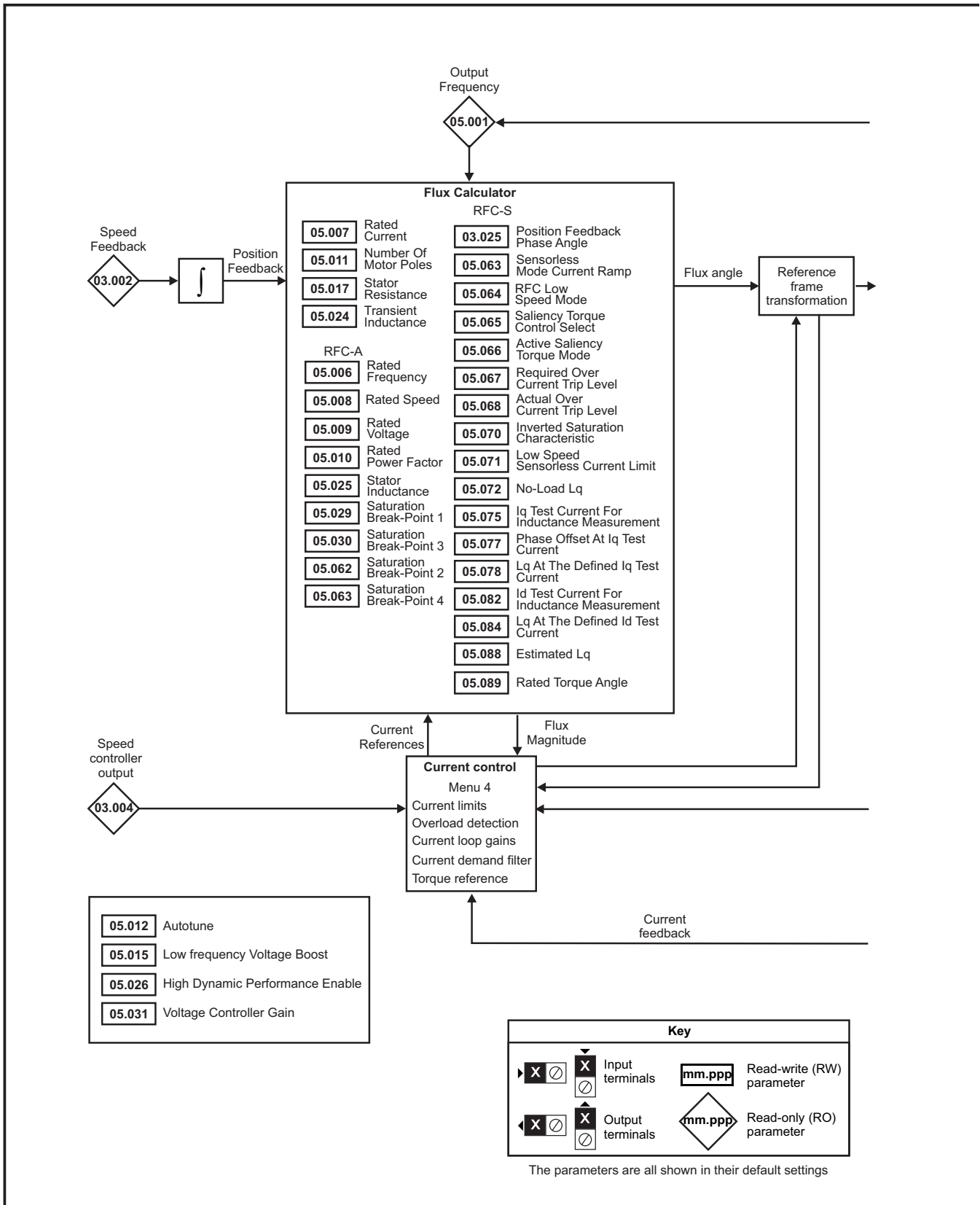

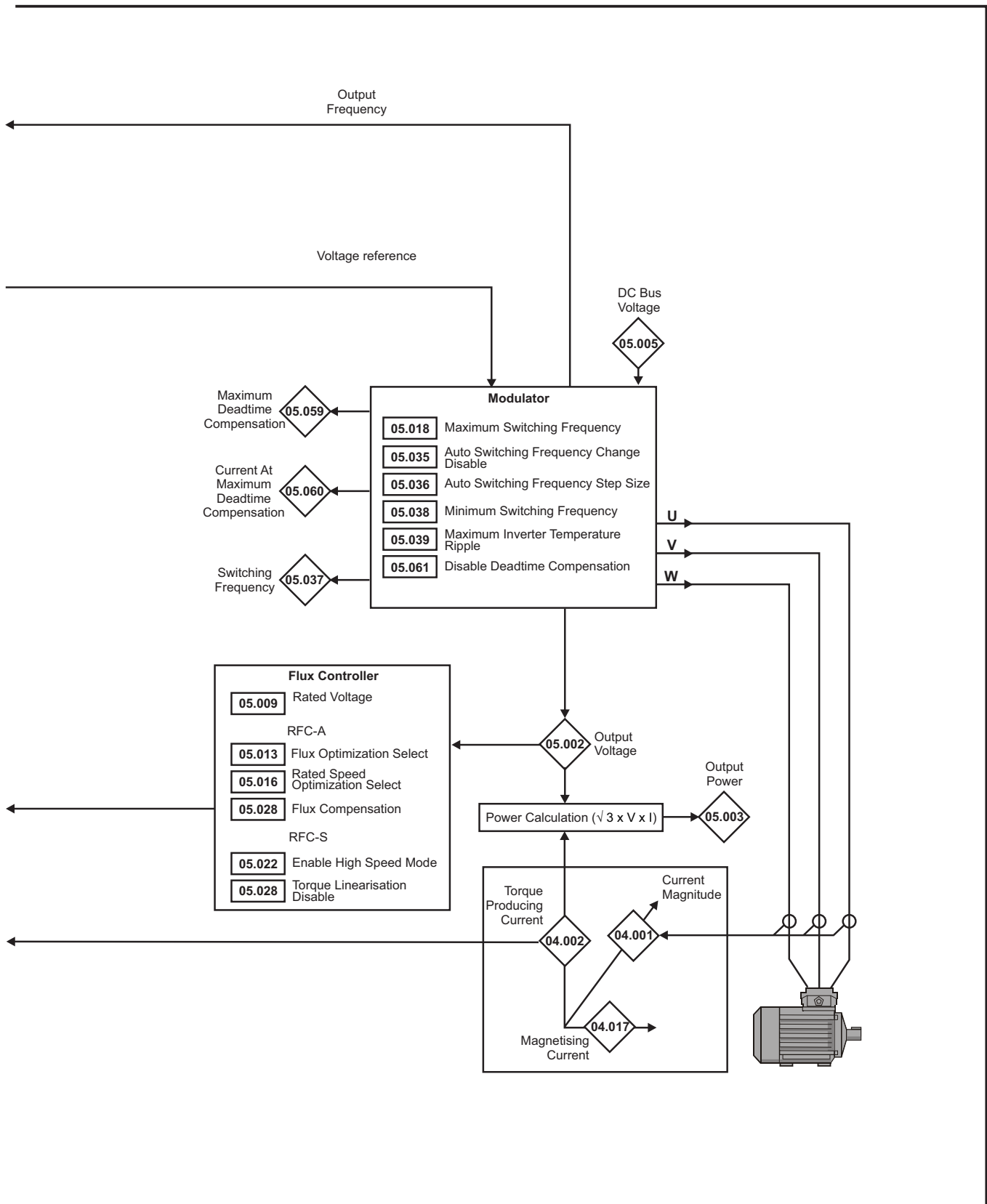

Safety information	Product information	Mechanical installation	Electrical installation	Getting started	Basic parameters	Running the motor	Optimization	Drive communication	NV Media Card Operation	Onboard PLC	Advanced parameters	Diagnostics	UL information
--------------------	---------------------	-------------------------	-------------------------	-----------------	------------------	-------------------	--------------	---------------------	-------------------------	-------------	---------------------	-------------	----------------

Parameter	Range(⊕)			Default(⇒)			Type						
	OL	RFC-A	RFC-S	OL	RFC-A	RFC-S	RO	Num	ND	NC	PT	FI	
05.001	Output Frequency	VM_SPEED FREQ_REF	±2000.0 Hz					RO	Num	ND	NC	PT	FI
05.002	Output Voltage	0 to VM_AC_VOLTAGE V						RO	Num	ND	NC	PT	FI
05.003	Output Power	VM_POWER kW						RO	Num	ND	NC	PT	FI
05.004	Motor Rpm	±180000 rpm						RO	Num	ND	NC	PT	FI
05.005	D.c. Bus Voltage	0 to VM_DC_VOLTAGE V						RO	Num	ND	NC	PT	FI
05.006	Rated Frequency	0.0 to 599.0 Hz	0.0 to 550.0 Hz		50Hz: 50.0 60Hz: 60.0		RW	Num					US
05.007	Rated Current	0.000 to VM_RATED_CURRENT A			Maximum Heavy Duty Rating (11.032)			RW	Num		RA		US
05.008	Rated Speed	0 to 35940 rpm	0.00 to 33000.00 rpm		50Hz: 1500 rpm 60Hz: 1800 rpm		50Hz: 1450.00 rpm 60Hz: 1750.00 rpm	3000.00 rpm	RW	Num			US
05.009	Rated Voltage	0 to VM_AC_VOLTAGE_SET			200 V drive: 230 V 50 Hz - 400 V drive: 400 V 60 Hz - 400 V drive: 460 V 575 V drive: 575 V 690 V drive: 690 V			RW	Num		RA		US
05.010	Rated Power Factor	0.000 to 1.000			0.850			RW	Num		RA		US
05.011	Number Of Motor Poles	Automatic (0) to 480 Poles (240)			Automatic (0)		6 Poles (3)	RW	Num				US
05.012	Autotune	None (0), Basic (1), Improved (2)	None (0), Basic (1), Improved (2), Inertia 1 (3), Inertia 2 (4)	None (0), Stationary (1), Rotating (2), Inertia 1 (3), Inertia 2 (4), Full Stationary (5)	None (0)			RW	Num		NC		
05.013	Open Loop: Dynamic V To F Select	Off (0) or On (1)			Off (0)			RW	Bit				US
	RFC A: Flux Optimisation Select	Off (0) or On (1)			Off (0)			RW	Bit				US
	RFC S: Minimal Movement Phasing Test Mode			Free (0), Constrained (1)	Free (0)			RW	Txt				US
05.014	Open-loop Control Mode	Ur S (0), Ur (1), Fixed (2), Ur Auto (3), Ur I (4), Square (5),			Ur I (4)			RW	Txt				US
	Phasing Test On Enable			Disabled (0), Short (1), Short Once (2), Long (3), Long Once (4)	Disabled (0)			RW	Txt				US
05.015	Low Frequency Voltage Boost	0.0 to 25.0 %			3.0 %			RW	Num				US
	Minimal Movement Phasing Test Current			1 % (0), 2 % (1), 3 % (2), 6 % (3), 12 % (4), 25 % (5), 50 % (6), 100 % (7)	1 % (0)			RW	Txt				US
05.016	Rated Speed Optimization Select	Disabled (0), Classic Slow (1), Classic Fast (2), Combined (3), VARs Only (4), Voltage Only (5)			Disabled (0)			RW	Txt				US
	Minimal Movement Phasing Test Angle			0.00 to 25.00 °	0.00 °			RW	Num				US
05.017	Stator Resistance	0.000000 to 1000.000000 Ω			0.000000 Ω			RW	Num		RA		US
05.018	Maximum Switching Frequency	2 kHz (0), 3 kHz (1), 4 kHz (2), 6 kHz (3), 8 kHz (4), 12 kHz (5), 16 kHz (6)			3 kHz (1)		6 kHz (3)	RW	Txt		RA		US
05.019	Open Loop: High Stability Space Vector Modulation	Off (0) or On (1)			Off (0)			RW	Bit				US
	RFC A: Rated Speed Optimisation Minimum Frequency	0 to 100 %			10 %			RW	Num				US
	RFC S: Minimal Movement Phasing Test Mechanical Load Phase			-180 to 179 °	-180 °			RW	Num				US
05.020	Quasi-square Enable	Off (0) or On (1)			Off (0)			RW	Bit				US
	Rated Speed Optimization Minimum Load	0 to 100 %			50 %			RW	Num				US
05.021	Mechanical Load Test Level	0 to 100 %			0 %			RW	Num				US
05.022	Enable High Speed Mode			Limit (-2), Limit (Servo) (-1), Disable (0), Enable (Servo) (1), Enable (2)	Disable (0)			RW	Txt				US
05.023	D.c. Bus Voltage High Range	0 to VM_HIGH_DC_VOLTAGE V						RO	Num	ND	NC	PT	FI
05.024	Transient Inductance	0.000 to 500.000 mH			0.000 mH			RW	Num		RA		US
	Ld			0.000 to 500.000 mH	0.000 mH			RW	Num		RA		US
05.025	Stator Inductance	0.00 to 5000.00 mH			0.00 mH			RW	Num		RA		US
05.026	High Dynamic Performance Enable	Off (0) or On (1)			Off (0)			RW	Bit				US

Safety information	Product information	Mechanical installation	Electrical installation	Getting started	Basic parameters	Running the motor	Optimization	Drive communication	NV Media Card Operation	Onboard PLC	Advanced parameters	Diagnostics	UL information
--------------------	---------------------	-------------------------	-------------------------	-----------------	------------------	-------------------	--------------	---------------------	-------------------------	-------------	---------------------	-------------	----------------

Parameter	Range(↕)			Default(⇌)			Type						
	OL	RFC-A	RFC-S	OL	RFC-A	RFC-S							
05.027	Open Loop: Enable Slip Compensation	Off (0) or On (1)		On (1)			RW	Bit				US	
	RFC A: Flux Control Gain	±10.0		1.0			RW	Num				US	
	RFC S: Flux Control Gain			0.1 to 10.0			RW	Num				US	
05.028	Flux Compensation	0 to 2		0			RW	Num				US	
	Torque Linearization Disable			Off (0) or On (1)			RW	Bit				US	
05.029	Saturation Breakpoint 1	0.0 to 100.0 %		50.0 %			RW	Num				US	
05.030	Saturation Breakpoint 3	0.0 to 100.0 %		75.0 %			RW	Num				US	
05.031	Voltage Controller Gain	1 to 30		1			RW	Num				US	
05.032	Torque Per Amp	0.00 to 500.00 Nm/A					RO	Num	ND	NC	PT		
				0.00 to 500.00 Nm/A			RW	Num				US	
05.033	Volts Per 1000 rpm			98			RW	Num				US	
05.034	Percentage Flux	0.0 to 150.0 %					RO	Num	ND	NC	PT	FI	
05.035	Auto-switching Frequency Change Disable	Enabled (0), Disabled (1), No Ripple Detect (2)			Enabled (0)			RW	Txt				US
05.036	Auto-switching Frequency Step Size	1 to 2			2			RW	Num				US
05.037	Switching Frequency	2 kHz (0), 3 kHz (1), 4 kHz (2), 6 kHz (3), 8 kHz (4), 12 kHz (5), 16 kHz (6)						RO	Txt	ND	NC	PT	
05.038	Minimum Switching Frequency	0 to VM_MIN_SWITCHING_FREQUENCY kHz			2 (0) kHz			RW	Txt				US
05.039	Maximum Inverter Temperature Ripple	20 to 60 °C			60 °C			RW	Num				US
05.040	Spin Start Boost	0.0 to 10.0		1.0			RW	Num				US	
05.041	Voltage Headroom	0 to 20 %			0 %			RW	Num				US
05.042	Reverse Output Phase Sequence	Off (0) or On (1)			Off (0)			RW	Bit				US
05.044	Stator Temperature Source	An In 3 (0), User (1), P1 Drive (2), P1 Slot 1 (3), P1 Slot 2 (4), P1 Slot 3 (5), P1 Slot 4 (6)			An In 3 (0)*			RW	Txt				US
05.045	User Stator Temperature	-50 to 300 °C			0 °C			RW	Num				US
05.046	Stator Temperature	-50 to 300 °C						RO	Num	ND	NC	PT	
05.047	Stator Temperature Coefficient	0.00000 to 0.10000 °C ⁻¹			0.00390 °C ⁻¹			RW	Num				US
05.048	Stator Base Temperature	-50 to 300 °C			0 °C			RW	Num				US
05.049	Enable Stator Compensation	Off (0) or On (1)			Off (0)			RW	Bit				US
05.050	Temperature Compensated Stator Resistance	0.000000 to 1000.000000 Ω	0.000000 to 1000.000000					RO	Num	ND	NC	PT	
05.051	Rotor Temperature Source	An In 3 (0), User (1), P1 Drive (2), P1 Slot 1 (3), P1 Slot 2 (4), P1 Slot 3 (5), P1 Slot 4 (6)			An In 3 (0)*			RW	Txt				US
05.052	User Rotor Temperature	-50 to 300 °C			0 °C			RW	Num				US
05.053	Rotor Temperature	-50 to 300 °C						RO	Num	ND	NC	PT	
05.054	Rotor Temperature Coefficient	0.00000 to 0.10000 °C ⁻¹			0.00390 °C ⁻¹		0.00100 °C ⁻¹	RW	Num				US
05.055	Rotor Base Temperature	-50 to 300 °C			0 °C			RW	Num				US
05.056	Enable Rotor Compensation	Off (0) or On (1)			Off (0)			RW	Bit				US
05.057	Temperature compensated rated speed	0.00 to 18000.00 rpm	0.00 to 50000.00 rpm					RO	Num	ND	NC	PT	
	Rotor Temperature Compensation			0.000 to 2.000			RW	Num	ND	NC	PT		
05.059	Maximum Deadtime Compensation	0.000 to 10.000 μs						RO	Num		NC	PT	US
05.060	Current At Maximum Deadtime Compensation	0.00 to 100.00 %						RO	Num		NC	PT	US
05.061	Disable Deadtime Compensation	Off (0) or On (1)			Off (0)			RW	Bit				US
05.062	Saturation Breakpoint 2	0.0 to 100.0 %		0.0 %			RW	Num				US	
05.063	Saturation Breakpoint 4	0.0 to 100.0 %		0.0 %			RW	Num				US	
	Sensorless Mode Current Ramp				0.00 to 1.00 s		0.20 s	RW	Num				US
05.064	RFC Low Speed Mode				Injection (0), Non-salient (1), Current (2), Current No Test (3), Current Step (4), Current Only (5)		Current (2)	RW	Txt				US
05.065	Saliency Torque Control Select				Disabled (0), Low (1), High (2), Auto (3)		Disabled (0)	RW	Txt				US
05.066	Active Saliency Torque Mode				Disabled (0), Low (1), High (2)			RO	Txt	ND	NC	PT	
05.067	Required Over-current Trip Level				0 to 100 %		0 %	RW	Num				US
05.068	Actual Over-current Trip Level				0 to 500 %			RO	Num	ND	NC	PT	
05.069	Over current Trip Level as Percentage of Rated Current				0 to 1000 %		0 %	RW	Num				US
05.070	Inverted Saturation Characteristic				Off (0) or On (1)		Off (0)	RW	Bit				US

Safety information	Product information	Mechanical installation	Electrical installation	Getting started	Basic parameters	Running the motor	Optimization	Drive communication	NV Media Card Operation	Onboard PLC	Advanced parameters	Diagnostics	UL information
Parameter		Range(↕)			Default(⇒)			Type					
		OL	RFC-A	RFC-S	OL	RFC-A	RFC-S						
05.071	Low Speed Sensorless Mode Current Limit			0.0 to 1000.0 %			100.0 %	RW	Num		RA		US
05.072	No-load Lq			0.000 to 500.000 mH			0.000 mH	RW	Num		RA		US
05.075	q Axis Current For Inductance Values With Current			0 to 200 %			100 %	RW	Num				US
05.077	Phase Offset At Defined Iq Current			±90.0°			0.0°	RW	Num		RA		US
05.078	Lq At The Defined Iq Current			0.000 to 500.000 mH			0.000 mH	RW	Num		RA		US
05.079	Lq Incremental Inductance At Defined Iq Current			0.000 to 500.000 mH			0.000 mH	RW	Num		RA		US
05.082	d Axis Current For Inductance Values With Current			-100 to 0 %			-100%	RW	Num				US
05.084	Lq At The Defined Id Current			0.000 to 500.000 mH			0.000 mH	RW	Num		RA		US
05.085	Lq Incremental Inductance At Defined Id Current			0.000 to 500.000 mH			0.000 mH	RW	Num		RA		US
05.087	User Defined Rated Torque Angle			0 to 90 °			0 °	RW	Num				US
05.088	Estimated Lq			0.000 to 500.000 mH				RO	Num	ND	NC	PT	FI
05.089	Rated Torque Angle			0 to 90°				RO	Num	ND	NC	PT	

* User (1) on Unidrive M702.

12.7 Menu 6: Sequencer and clock

Figure 12-15 Menu 6 logic diagram

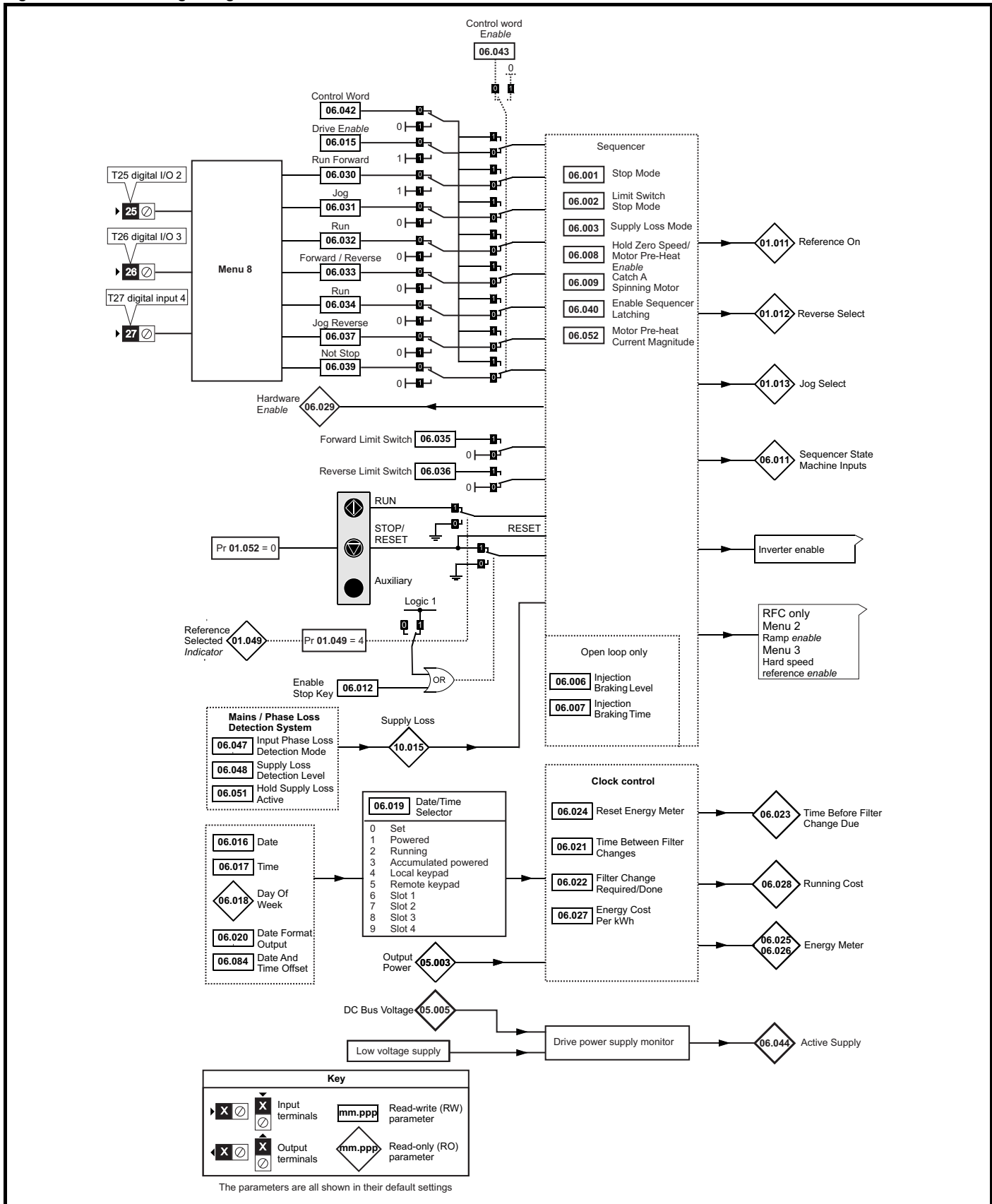

* Not available on Unidrive M702.

** Terminal 7 on Unidrive M702.

*** Terminal 8 on Unidrive M702.

Figure 12-16 Menu 6 logic diagram: Under voltage and power supply control

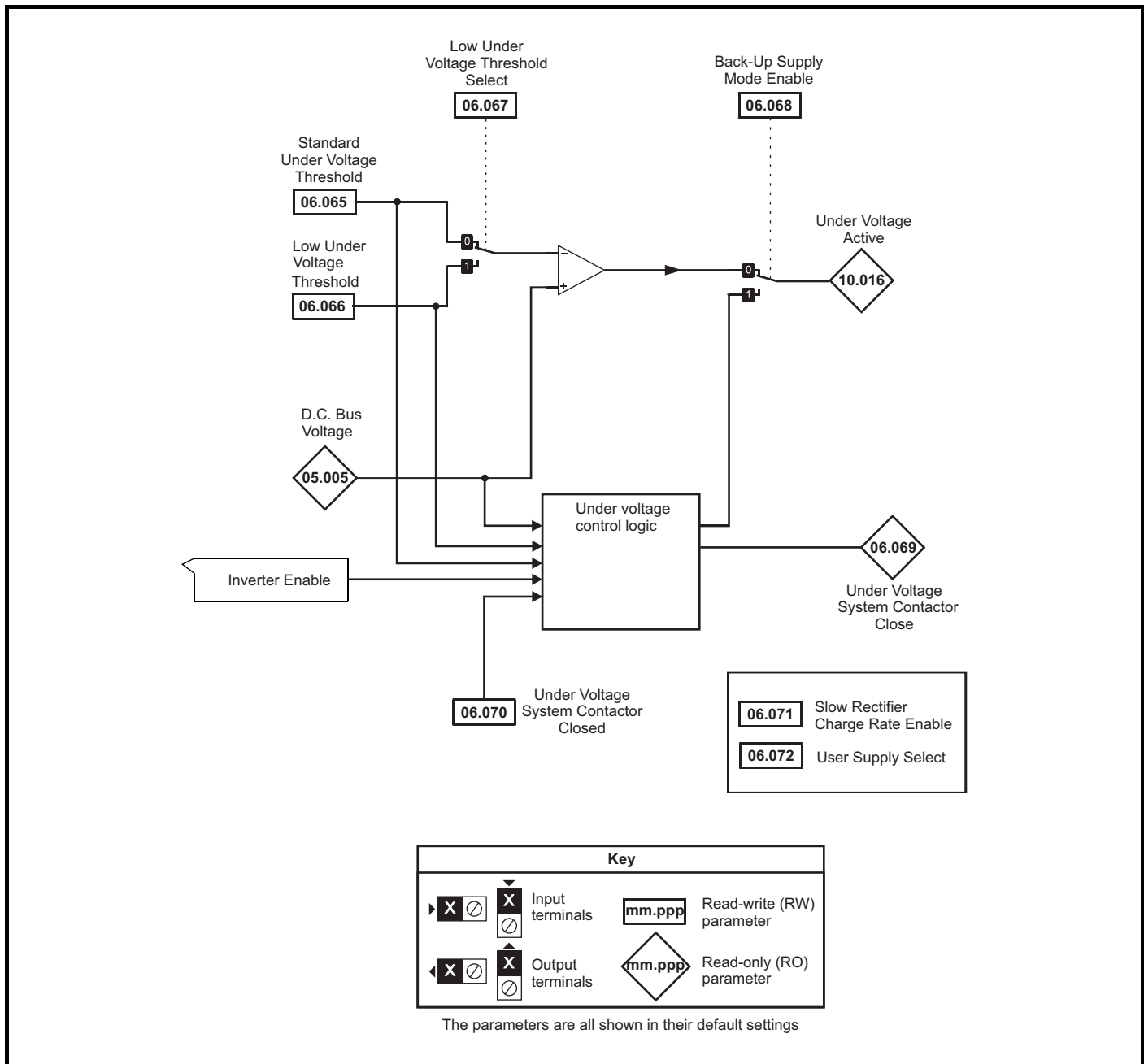

Safety information	Product information	Mechanical installation	Electrical installation	Getting started	Basic parameters	Running the motor	Optimization	Drive communication	NV Media Card Operation	Onboard PLC	Advanced parameters	Diagnostics	UL information
--------------------	---------------------	-------------------------	-------------------------	-----------------	------------------	-------------------	--------------	---------------------	-------------------------	-------------	---------------------	-------------	----------------

Parameter	Range(⇅)		Default(⇄)			Type							
	OL	RFC-A / S	OL	RFC-A	RFC-S								
06.001	Stop Mode	Coast (0), Ramp (1), Ramp dc I (2), dc I (3), Timed dc I (4), Disable (5)	Coast (0), Ramp (1), No Ramp (2)	Ramp (1)	Ramp (1)	No Ramp (2)	RW	Txt					US
06.002	Limit Switch Stop Mode		Stop (0) or Ramp (1)		Stop (0)		RW	Txt					US
06.003	Supply Loss Mode	Disable (0), Ramp Stop (1), Ride Thru (2)	Disable (0), Ramp Stop (1), Ride Thru (2), Limit Stop (3)	Disable (0)			RW	Txt					US
06.006	Injection Braking Level	0.0 to 150.0 %		100.0 %			RW	Num		RA			US
06.007	Injection Braking Time	0.0 to 100.0 s		1.0 s			RW	Num					US
06.008	Hold Zero Speed	Off (0) or On (1)		Off (0)		On (1)	RW	Bit					US
06.009	Catch A Spinning Motor	Disable (0), Enable (1), Fwd Only (2), Rev Only (3)		Disable (0)	Enable (1)		RW	Txt					US
06.010	Enable Conditions	000000000000 to 111111111111					RO	Bin	ND	NC	PT		
06.011	Sequencer State Machine Inputs	000000 to 111111					RO	Bin	ND	NC	PT		
06.012	Enable Stop Key	Off (0) or On (1)		Off (0)			RW	Bit					US
06.013	Enable Auxiliary Key	Disabled (0), Forward / Reverse (1), Run Reverse (2)		Disabled (0)			RW	Txt					US
06.015	Drive Enable	Off (0) or On (1)		On (1)			RW	Bit					US
06.016	Date	00-00-00 to 31-12-99		00-00-00			RW	Date	ND	NC	PT		
06.017	Time	00:00:00 to 23:59:59					RW	Time	ND	NC	PT		
06.018	Day Of Week	Sunday (0), Monday (1), Tuesday (2), Wednesday (3), Thursday (4), Friday (5), Saturday (6)					RO	Txt	ND	NC	PT		
06.019	Date/Time Selector	Set (0), Powered (1), Running (2), Acc Powered (3), Local Keypad (4), Remote Keypad (5), Slot 1 (6), Slot 2 (7), Slot 3 (8), Slot 4 (9)		Powered (1)			RW	Txt					US
06.020	Date Format	Std (0) or US (1)		Std (0)			RW	Txt					US
06.021	Time Between Filter Changes	0 to 30000 Hours		0 Hours			RW	Num					US
06.022	Filter Change Required / Change Done	Off (0) or On (1)		Off (0)			RW	Bit	ND	NC			
06.023	Time Before Filter Change Due	0 to 30000 Hours					RO	Num	ND	NC	PT	PS	
06.024	Reset Energy Meter	Off (0) or On (1)		Off (0)			RW	Bit					
06.025	Energy Meter: MWh	-999.9 to 999.9 MWh					RO	Num	ND	NC	PT	PS	
06.026	Energy Meter: kWh	±99.99 kWh					RO	Num	ND	NC	PT	PS	
06.027	Energy Cost Per kWh	0.0 to 600.0		0.0			RW	Num					US
06.028	Running Cost	±32000					RO	Num	ND	NC	PT		
06.029	Hardware Enable	Off (0) or On (1)					RO	Bit	ND	NC	PT		
06.030	Run Forward	Off (0) or On (1)		Off (0)			RW	Bit		NC			
06.031	Jog	Off (0) or On (1)		Off (0)			RW	Bit		NC			
06.032	Run Reverse	Off (0) or On (1)		Off (0)			RW	Bit		NC			
06.033	Forward/Reverse	Off (0) or On (1)		Off (0)			RW	Bit		NC			
06.034	Run	Off (0) or On (1)		Off (0)			RW	Bit		NC			
06.035	Forward Limit Switch	Off (0) or On (1)		Off (0)			RW	Bit		NC			
06.036	Reverse Limit Switch	Off (0) or On (1)		Off (0)			RW	Bit		NC			
06.037	Jog Reverse	Off (0) or On (1)		Off (0)			RW	Bit		NC			
06.039	Not Stop	Off (0) or On (1)		Off (0)			RW	Bit		NC			
06.040	Enable Sequencer Latching	Off (0) or On (1)		Off (0)			RW	Bit					US
06.041	Drive Event Flags	00 to 11		00			RW	Bin		NC			
06.042	Control Word	00000000000000 to 1111111111111111		0000000000000000			RW	Bin		NC			
06.043	Control Word Enable	Off (0) or On (1)		Off (0)			RW	Bit					US
06.044	Active Supply	Off (0) or On (1)					RO	Bit	ND	NC	PT		
06.045	Cooling Fan control	-10 to 11		10			RW	Num					US
06.046	Cooling Fan Speed	0 to 10					RO	Num	ND	NC	PT		
06.047	Input Phase Loss Detection Mode	Full (0), Ripple Only (1), Disabled (2)		Full (0)			RW	Txt					US
06.048	Supply Loss Detection Level	0 to VM_SUPPLY_LOSS_LEVEL V		200 V drive: 205 V 400 V drive: 410 V 575 V drive: 540 V 690 V drive: 540 V			RW	Num		RA			US
06.051	Hold Supply Loss Active	Off (0) or On (1)		Off (0)			RW	Bit		NC			
06.052	Motor Pre-heat Current Magnitude	0 to 100 %		0 %			RW	Num					US
06.053	Sleep / Wake Threshold	0.0 to VM_SPEED_FREQ_REF_UNIPOLAR		0.0			RW	Num					US
06.054	Sleep Time	0.0 to 250.0 s		10.0 s			RW	Num					US
06.055	Wake Time	0.0 to 250.0 s		10.0 s			RW	Num					US
06.056	Sleep Required	Off (0) or On (1)					RO	Bit	ND	NC	PT		
06.057	Sleep Active	Off (0) or On (1)					RO	Bit	ND	NC	PT		

Safety information	Product information	Mechanical installation	Electrical installation	Getting started	Basic parameters	Running the motor	Optimization	Drive communication	NV Media Card Operation	Onboard PLC	Advanced parameters	Diagnostics	UL information
--------------------	---------------------	-------------------------	-------------------------	-----------------	------------------	-------------------	--------------	---------------------	-------------------------	-------------	---------------------	-------------	----------------

Parameter		Range(⇅)		Default(⇄)			Type						
		OL	RFC-A / S	OL	RFC-A	RFC-S	RW	Txt				US	
06.058	Output Phase Loss Detection Time	0.5 s (0), 1.0 s (1), 2.0 s (2), 4.0 s (3)		0.5 s (0)			RW	Txt					US
06.059	Output Phase Loss Detection Enable	Disabled (0) or Enabled (1)		Disabled (0)			RW	Txt					US
06.060	Standby Mode Enable	Off (0) or On (1)		Off (0)			RW	Bit					US
06.061	Standby Mode Mask	0000000 to 1111111		0000000			RW	Bin					US
06.065	Standard Under Voltage Threshold	0 to VM_STD_UNDER_VOLTS V		200 V drive: 175 V 400 V drive: 330 V 575 V drive: 435 V 690 V drive: 435 V			RW	Num		RA			US
06.066	Low Under Voltage Threshold	24 to VM_LOW_UNDER_VOLTS V		200 V drive: 175 V 400 V drive: 330 V 575 V drive: 435 V 690 V drive: 435 V			RW	Num		RA			US
06.067	Low Under Voltage Threshold Select	Off (0) or On (1)		Off (0)			RW	Bit					US
06.068	Back Up Supply Mode Enable	Off (0) or On (1)		Off (0)			RW	Bit					US
06.069	Under-Voltage System Contactor Close	Off (0) or On (1)					RO	Bit	ND	NC	PT		
06.070	Under-Voltage System Contactor Closed	Off (0) or On (1)		Off (0)			RW	Bit					
06.071	Slow Rectifier Charge Rate Enable	Off (0) or On (1)		Off (0)			RW	Bit					US
06.072	User Supply Select	Off (0) or On (1)		Off (0)			RW	Bit					US
06.073	Braking IGBT Lower Threshold	0 to VM_DC_VOLTAGE_SET V		200 V drive: 390 V 400 V drive: 780 V 575 V drive: 930 V 690 V drive: 1120 V			RW	Num		RA			US
06.074	Braking IGBT Upper Threshold	0 to VM_DC_VOLTAGE_SET V		200 V drive: 390 V 400 V drive: 780 V 575 V drive: 930 V 690 V drive: 1120 V			RW	Num		RA			US
06.075	Low Voltage Braking IGBT Threshold	0 to VM_DC_VOLTAGE_SET V		0V			RW	Num		RA			US
06.076	Low Voltage Braking IGBT Threshold Select	Off (0) or On (1)		Off (0)			RW	Bit					
06.084	Date And Time Offset	± 12.00 Hours		0.00 Hours			RW	Num					US

RW	Read / Write	RO	Read only	Num	Number parameter	Bit	Bit parameter	Txt	Text string	Bin	Binary parameter	FI	Filtered
ND	No default value	NC	Not copied	PT	Protected parameter	RA	Rating dependent	US	User save	PS	Power-down save	DE	Destination

12.8 Menu 7: Analog I/O / Temperature Monitoring

Figure 12-17 Menu 7 logic diagram (Unidrive M700 / 701)

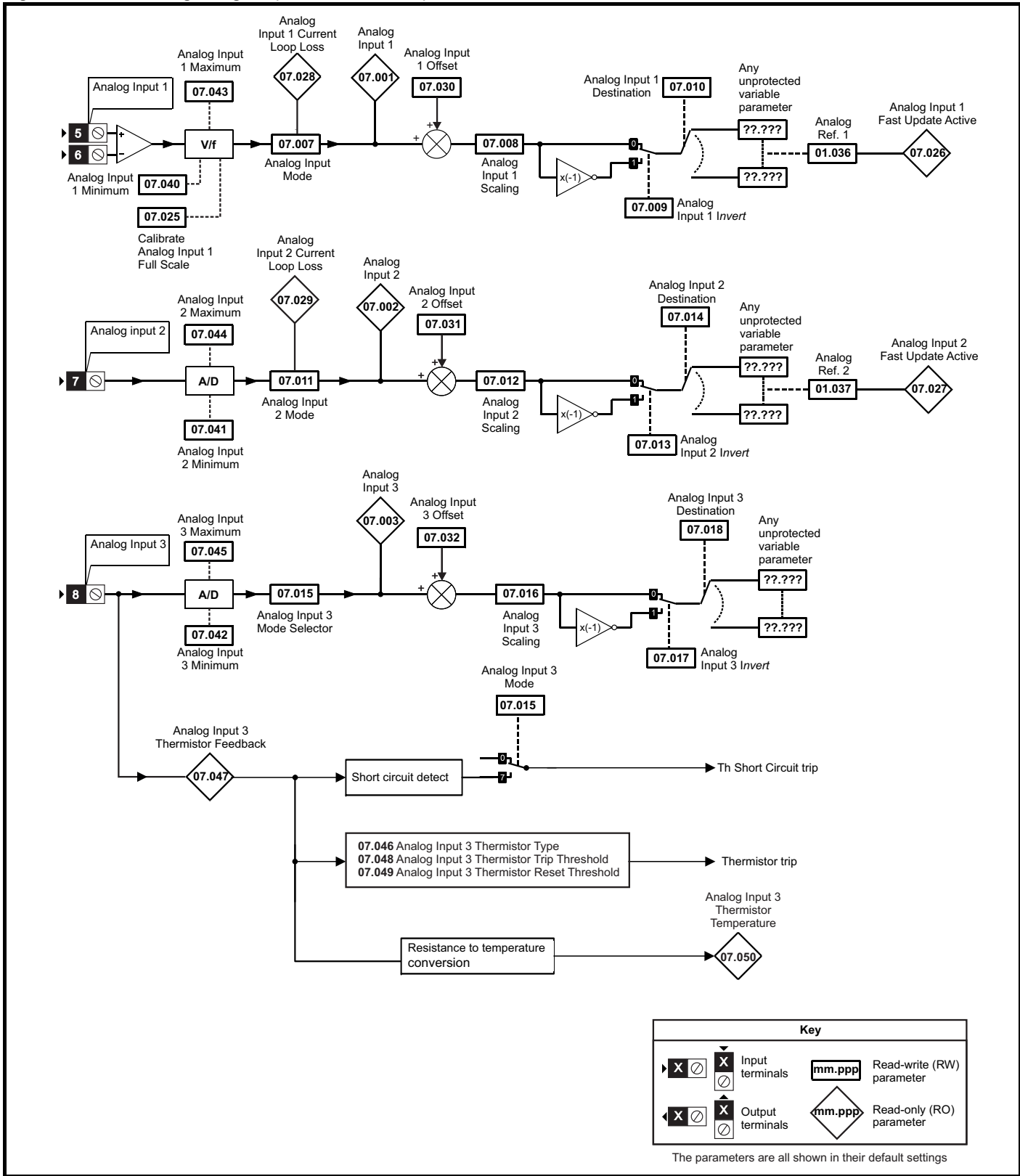

Figure 12-18 Menu 7 logic diagram (Unidrive M702 with date code 1710 or later)

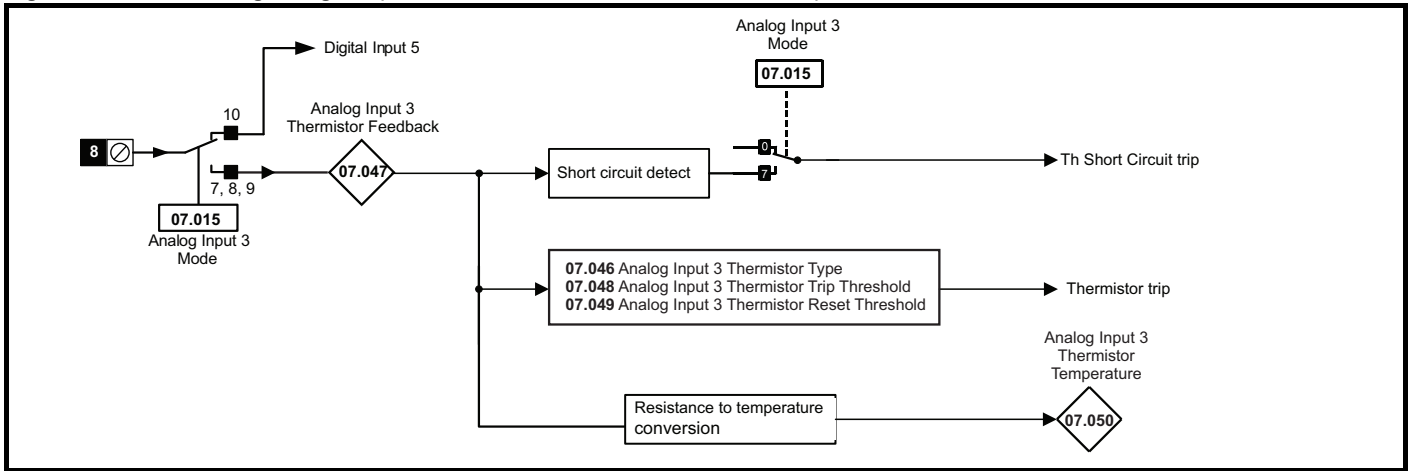

Figure 12-19 Menu 7 logic diagram: Analog outputs diagram (Unidrive M700 / 701)

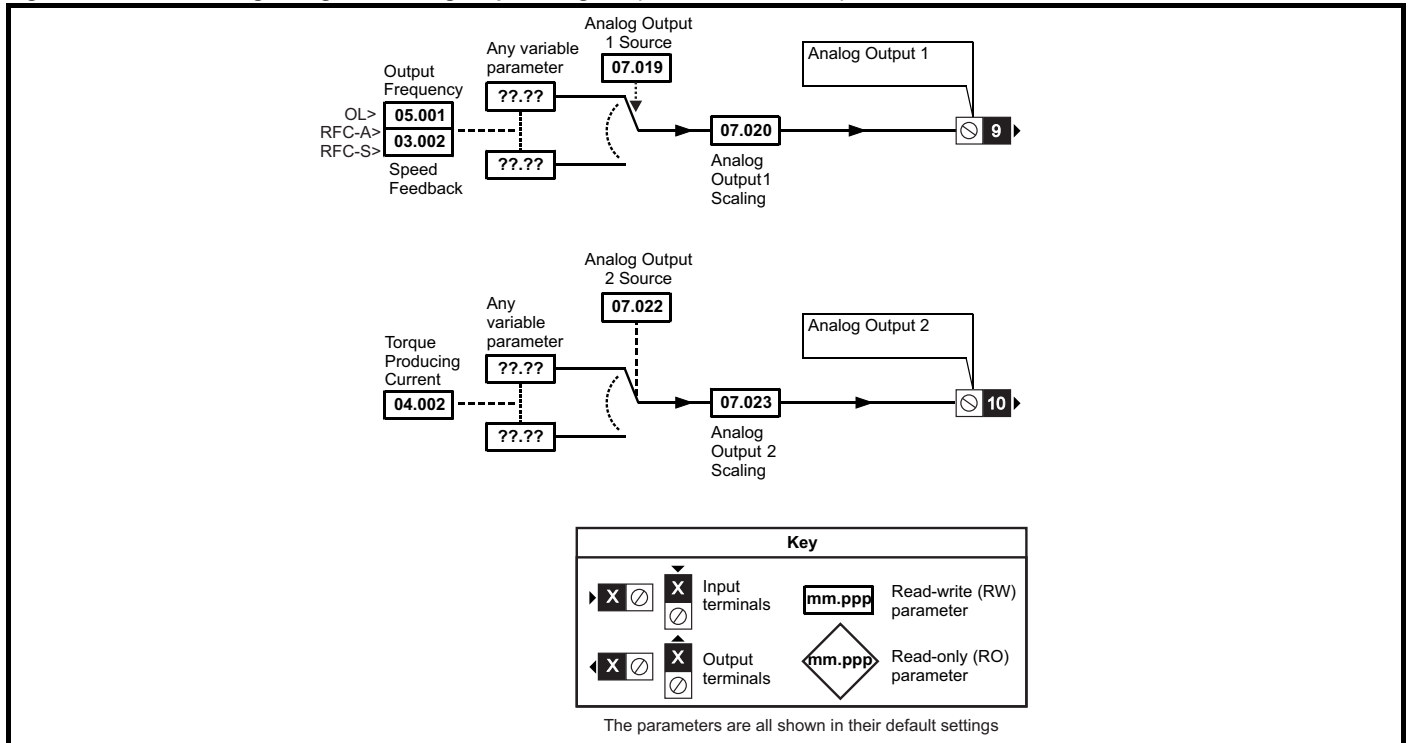
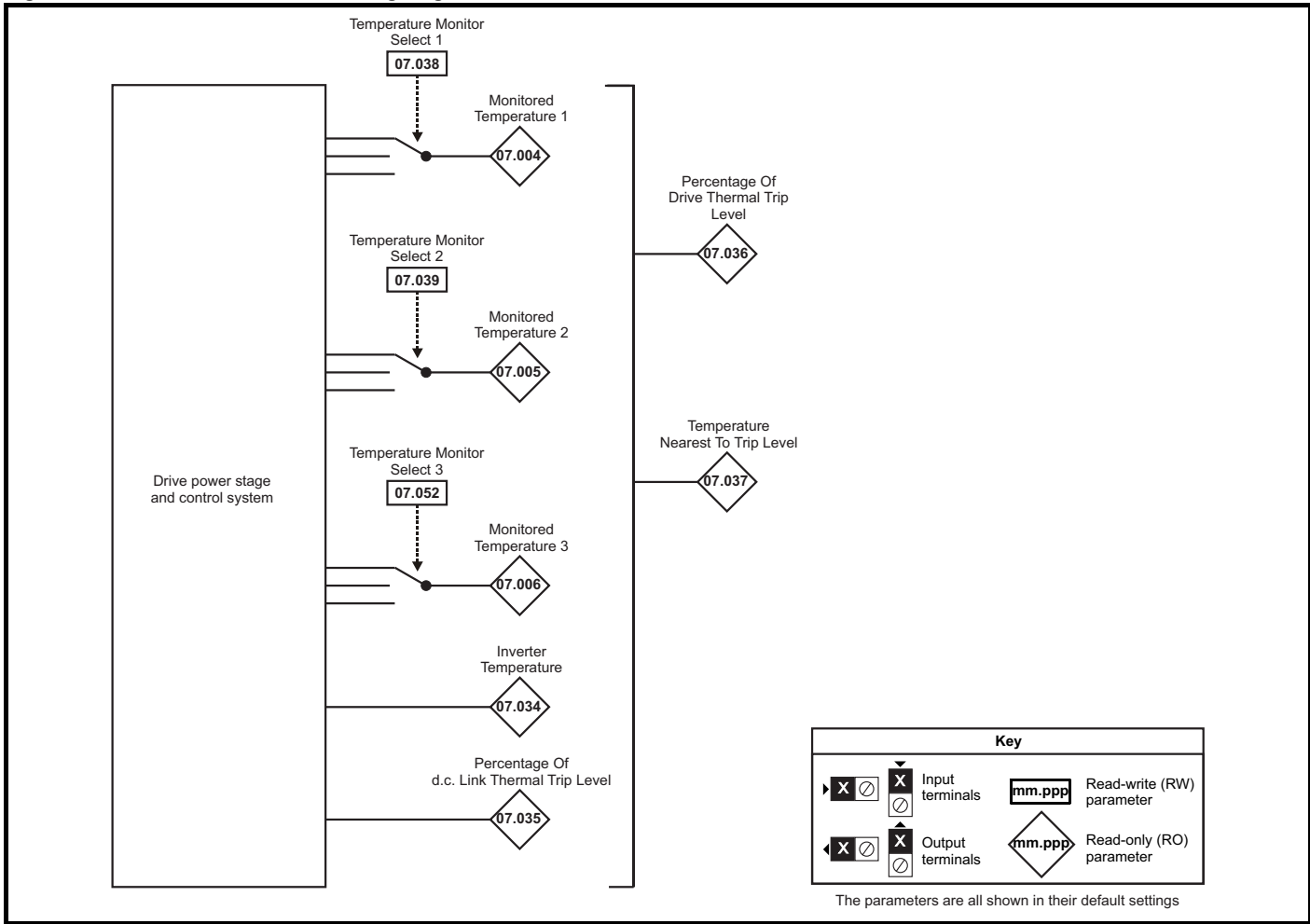

Figure 12-20 Menu 7 thermal monitoring diagram



Safety information	Product information	Mechanical installation	Electrical installation	Getting started	Basic parameters	Running the motor	Optimization	Drive communication	NV Media Card Operation	Onboard PLC	Advanced parameters	Diagnostics	UL information
--------------------	---------------------	-------------------------	-------------------------	-----------------	------------------	-------------------	--------------	---------------------	-------------------------	-------------	---------------------	-------------	----------------

Parameter	Range(±)		Default(⇒)			Type					
	OL	RFC-A / S	OL	RFC-A	RFC-S	RO	Num	ND	NC	PT	FI
07.001	Analog Input 1*	±100.00 %				RO	Num	ND	NC	PT	FI
07.002	Analog Input 2*	±100.00 %				RO	Num	ND	NC	PT	FI
07.003	Analog Input 3	±100.00 %				RO	Num	ND	NC	PT	FI
07.004	Monitored Temperature 1	±250 °C				RO	Num	ND	NC	PT	
07.005	Monitored Temperature 2	±250 °C				RO	Num	ND	NC	PT	
07.006	Monitored Temperature 3	±250 °C				RO	Num	ND	NC	PT	
07.007	Analog Input 1 Mode*	4-20 mA Low (-4), 20-4 mA Low (-3), 4-20 mA Hold (-2), 20-4 mA Hold (-1), 0-20 mA (0), 20-0 mA (1), 4-20 mA Trip (2), 20-4 mA Trip (3), 4-20 mA (4), 20-4 mA (5), Volt (6)		Volt (6)		RW	Txt				US
07.008	Analog Input 1 Scaling*	0.000 to 10.000		1.000		RW	Num				US
07.009	Analog Input 1 Invert*	Off (0) or On (1)		Off (0)		RW	Bit				US
07.010	Analog Input 1 Destination*	0.000 to 59.999		1.036		RW	Num	DE		PT	US
07.011	Analog Input 2 Mode*	4-20 mA Low (-4), 20-4 mA Low (-3), 4-20 mA Hold (-2), 20-4 mA Hold (-1), 0-20 mA (0), 20-0 mA (1), 4-20 mA Trip (2), 20-4 mA Trip (3), 4-20 mA (4), 20-4 mA (5), Volt (6)		Volt (6)		RW	Txt				US
07.012	Analog Input 2 Scaling*	0.000 to 10.000		1.000		RW	Num				US
07.013	Analog Input 2 Invert*	Off (0) or On (1)		Off (0)		RW	Bit				US
07.014	Analog Input 2 Destination*	0.000 to 59.999		1.037		RW	Num	DE		PT	US
07.015	Analog Input 3 Mode	M700, M701: Volt (6), Therm Short Cct (7), Thermistor (8), Therm No Trip (9) M702*: Therm Short Cct (7), Thermistor (8), Therm No Trip (9), Disable (10)		M700, M701: Volt (6) M702*: Disable (10)		RW	Txt				US
07.016	Analog Input 3 Scaling*	0.000 to 10.000		1.000		RW	Num				US
07.017	Analog Input 3 Invert*	Off (0) or On (1)		Off (0)		RW	Bit				US
07.018	Analog Input 3 Destination*	0.000 to 59.999		0.000		RW	Num	DE		PT	US
07.019	Analog Output 1 Source*	0.000 to 59.999	5.001	3.002		RW	Num			PT	US
07.020	Analog Output 1 Scaling*	0.000 to 10.000		1.000		RW	Num				US
07.022	Analog Output 2 Source*	0.000 to 59.999		4.002		RW	Num			PT	US
07.023	Analog Output 2 Scaling*	0.000 to 10.000		1.000		RW	Num				US
07.025	Calibrate Analog Input 1 Full Scale*	Off (0) or On (1)		Off (0)		RW	Bit		NC		
07.026	Analog Input 1 Fast Update Active*	Off (0) or On (1)				RO	Bit	ND	NC	PT	
07.027	Analog Input 2 Fast Update Active*	Off (0) or On (1)				RO	Bit	ND	NC	PT	
07.028	Analog Input 1 Current Loop Loss*	Off (0) or On (1)				RO	Bit	ND	NC	PT	
07.029	Analog Input 2 Current Loop Loss*	Off (0) or On (1)				RO	Bit	ND	NC	PT	
07.030	Analog Input 1 Offset*	±100.00 %		0.00 %		RW	Num				US
07.031	Analog Input 2 Offset*	±100.00 %		0.00 %		RW	Num				US
07.032	Analog Input 3 Offset*	±100.00 %		0.00 %		RW	Num				US
07.033	Power Output	±100.0 %				RO	Num	ND	NC	PT	
07.034	Inverter Temperature	±250 °C				RO	Num	ND	NC	PT	
07.035	Percentage Of d.c. Bus Thermal Trip Level	0 to 100 %				RO	Num	ND	NC	PT	
07.036	Percentage Of Drive Thermal Trip Level	0 to 100 %				RO	Num	ND	NC	PT	
07.037	Temperature Nearest To Trip Level	0 to 20999				RO	Num	ND	NC	PT	
07.038	Temperature Monitor Select 1	0 to 1999		1001		RW	Num				US
07.039	Temperature Monitor Select 2	0 to 1999		1002		RW	Num				US
07.040	Analog Input 1 Minimum*	±100.00 %		-100.00 %		RW	Num				US
07.041	Analog Input 2 Minimum*	±100.00 %		-100.00 %		RW	Num				US
07.042	Analog Input 3 Minimum*	±100.00 %		-100.00 %		RW	Num				US
07.043	Analog Input 1 Maximum*	±100.00 %		100.00 %		RW	Num				US
07.044	Analog Input 2 Maximum*	±100.00 %		100.00 %		RW	Num				US
07.045	Analog Input 3 Maximum*	±100.00 %		100.00 %		RW	Num				US
07.046	Analog Input 3 Thermistor Type	DIN44082 (0), KTY84 (1), PT100 (4W) (2), PT1000 (4W) (3), PT2000 (4W) (4), 2.0 mA (4W) (5), PT100 (2W) (6), PT1000 (2W) (7), PT2000 (2W) (8), 2.0 mA (2W) (9)		DIN44082 (0)		RW	Txt				US
07.047	Analog Input 3 Thermistor Feedback	0 to 5000 Ω				RO	Num	ND	NC	PT	
07.048	Analog Input 3 Thermistor Trip Threshold	0 to 5000 Ω		3300 Ω		RW	Num				US
07.049	Analog Input 3 Thermistor Reset Threshold	0 to 5000 Ω		1800 Ω		RW	Num				US
07.050	Analog Input 3 Thermistor Temperature	-50 to 300 °C				RO	Num	ND	NC	PT	
07.051	Analog Input 1 Full Scale*	0 to 65535				RO	Num	ND	NC	PT	PS
07.052	Temperature Monitor Select 3	0 to 1999		1		RW	Num				US

* Not available on Unidrive M702

** Not available on Unidrive M702 with date code earlier than 1710

RW	Read / Write	RO	Read only	Num	Number parameter	Bit	Bit parameter	Txt	Text string	Bin	Binary parameter	FI	Filtered
ND	No default value	NC	Not copied	PT	Protected parameter	RA	Rating dependent	US	User save	PS	Power-down save	DE	Destination

Safety information	Product information	Mechanical installation	Electrical installation	Getting started	Basic parameters	Running the motor	Optimization	Drive communication	NV Media Card Operation	Onboard PLC	Advanced parameters	Diagnostics	UL information
--------------------	---------------------	-------------------------	-------------------------	-----------------	------------------	-------------------	--------------	---------------------	-------------------------	-------------	----------------------------	-------------	----------------

12.9 Menu 8: Digital I/O

Figure 12-21 Menu 8 Digital input and outputs logic diagram (Unidrive M700 / M701)

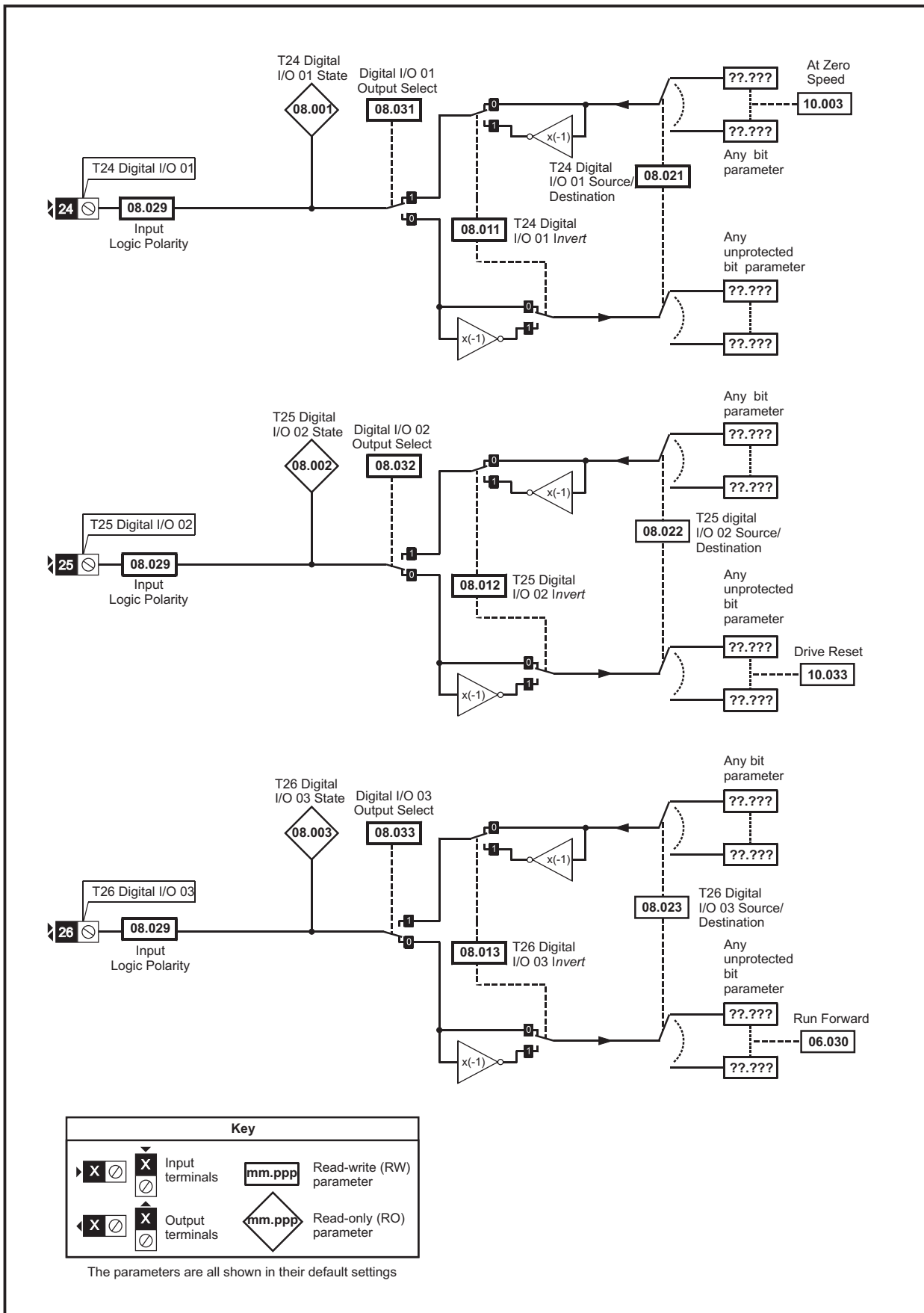

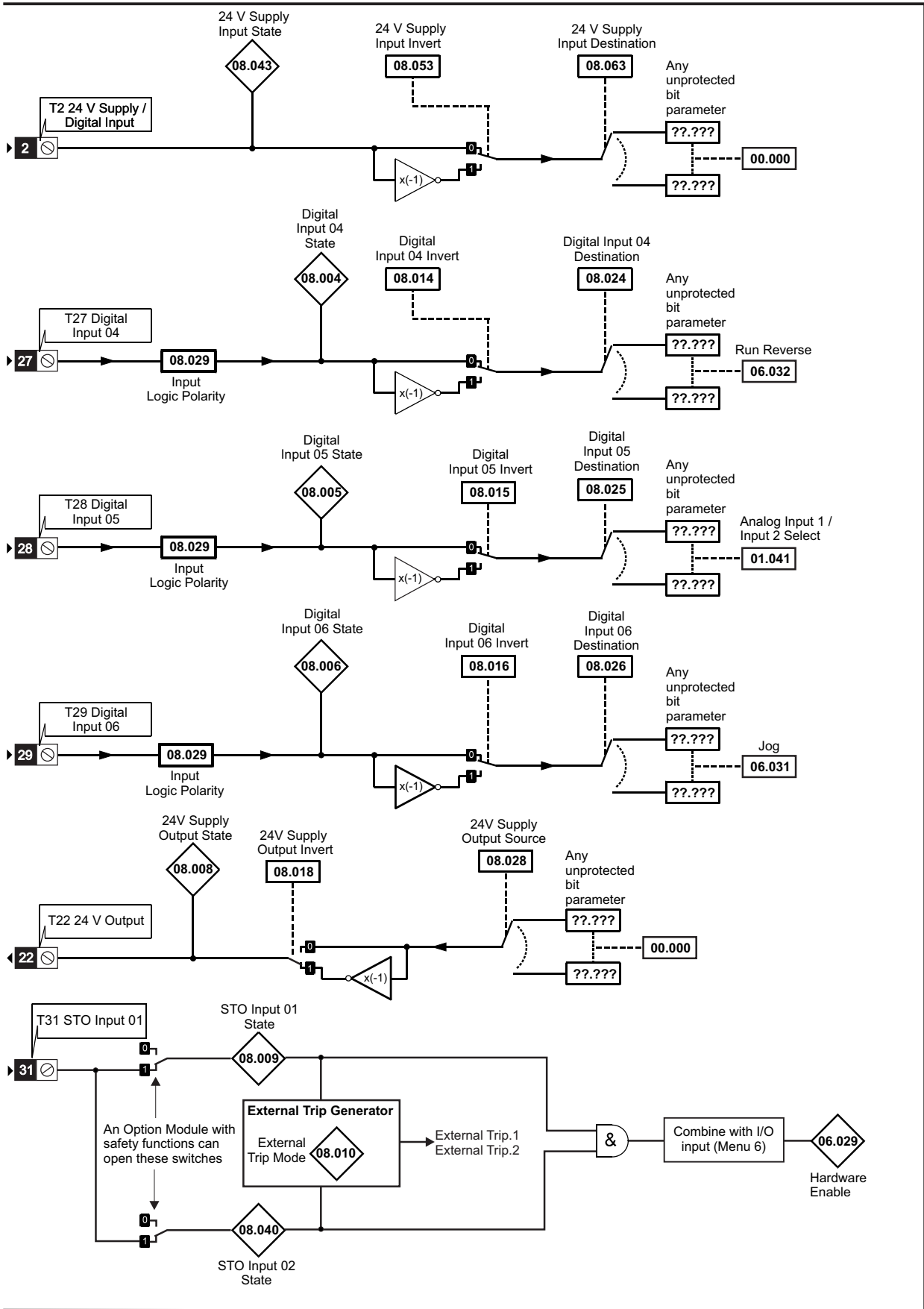
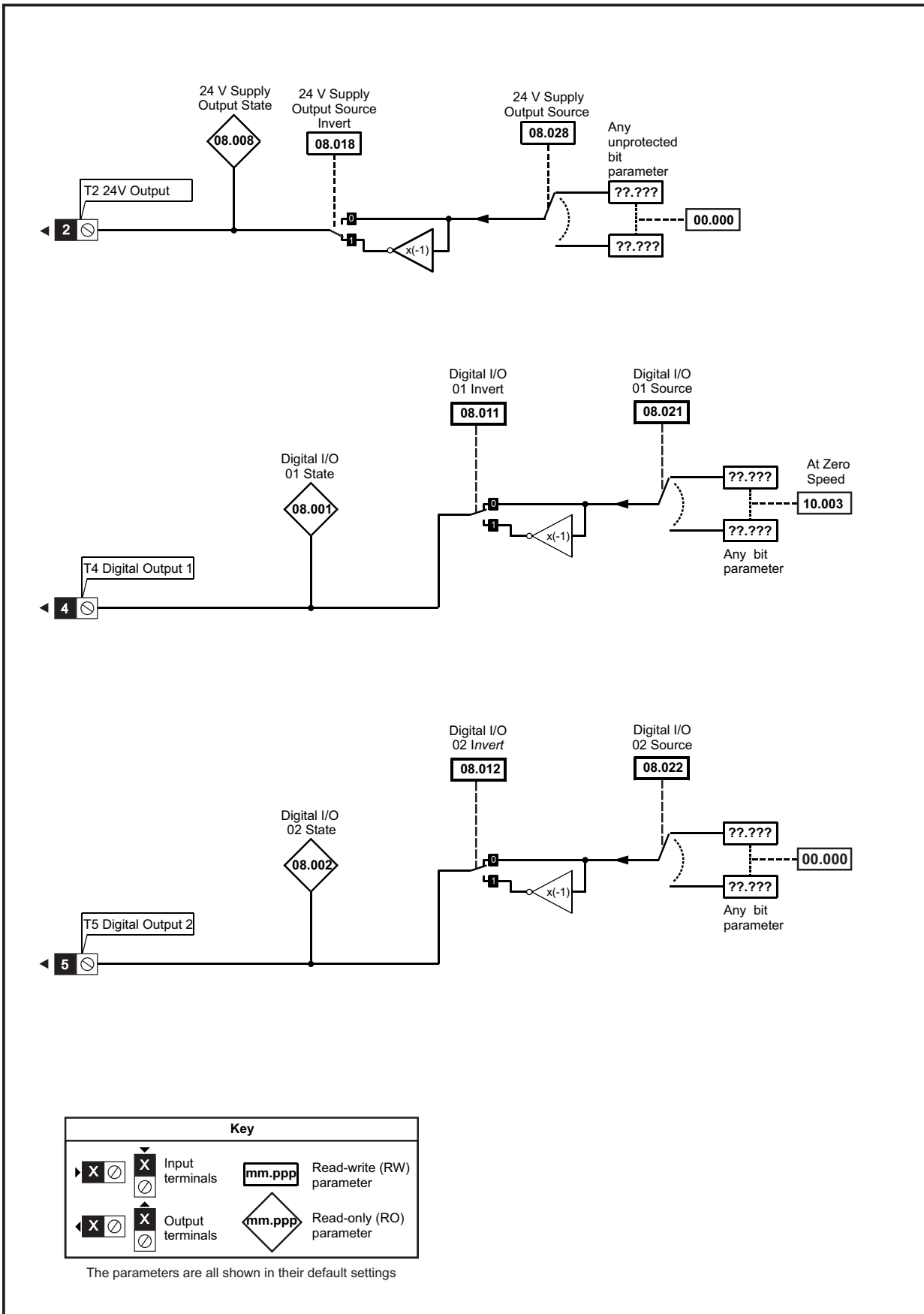

Figure 12-22 Menu 8 Digital input and outputs logic diagram (Unidrive M702)



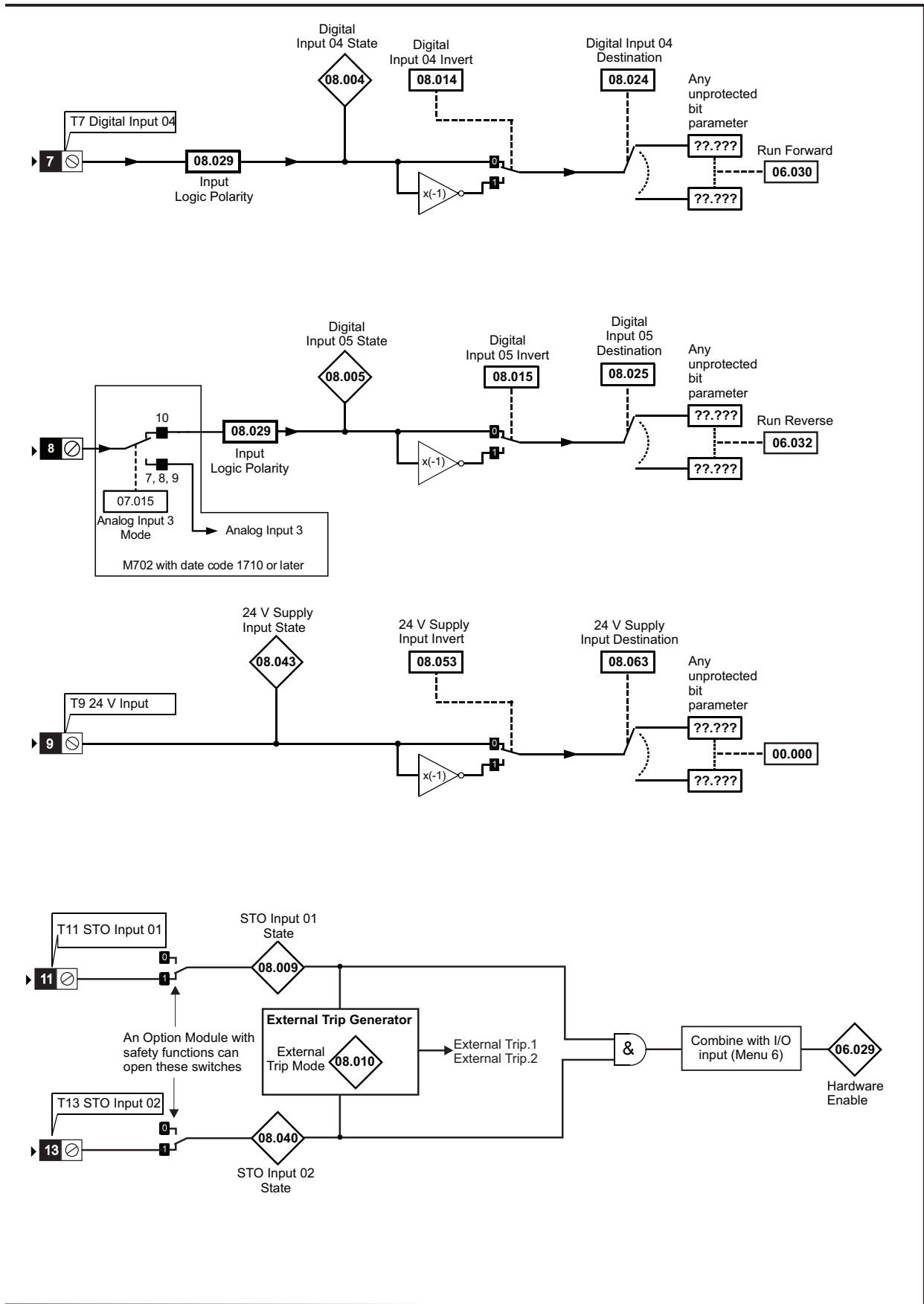

Figure 12-23 Menu 8 Relay output logic diagram

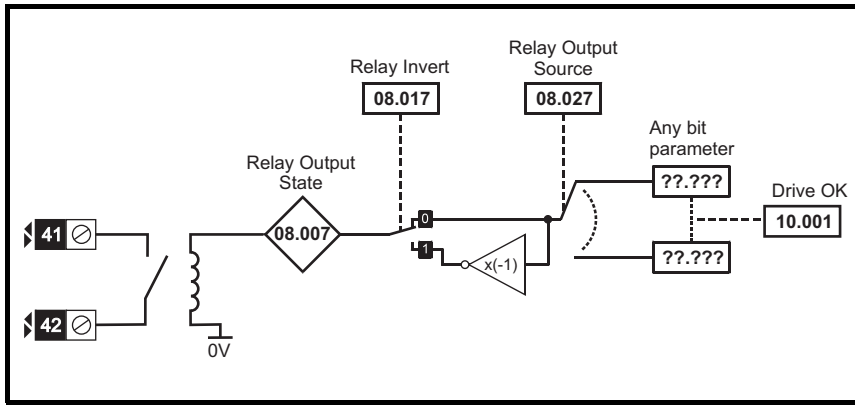
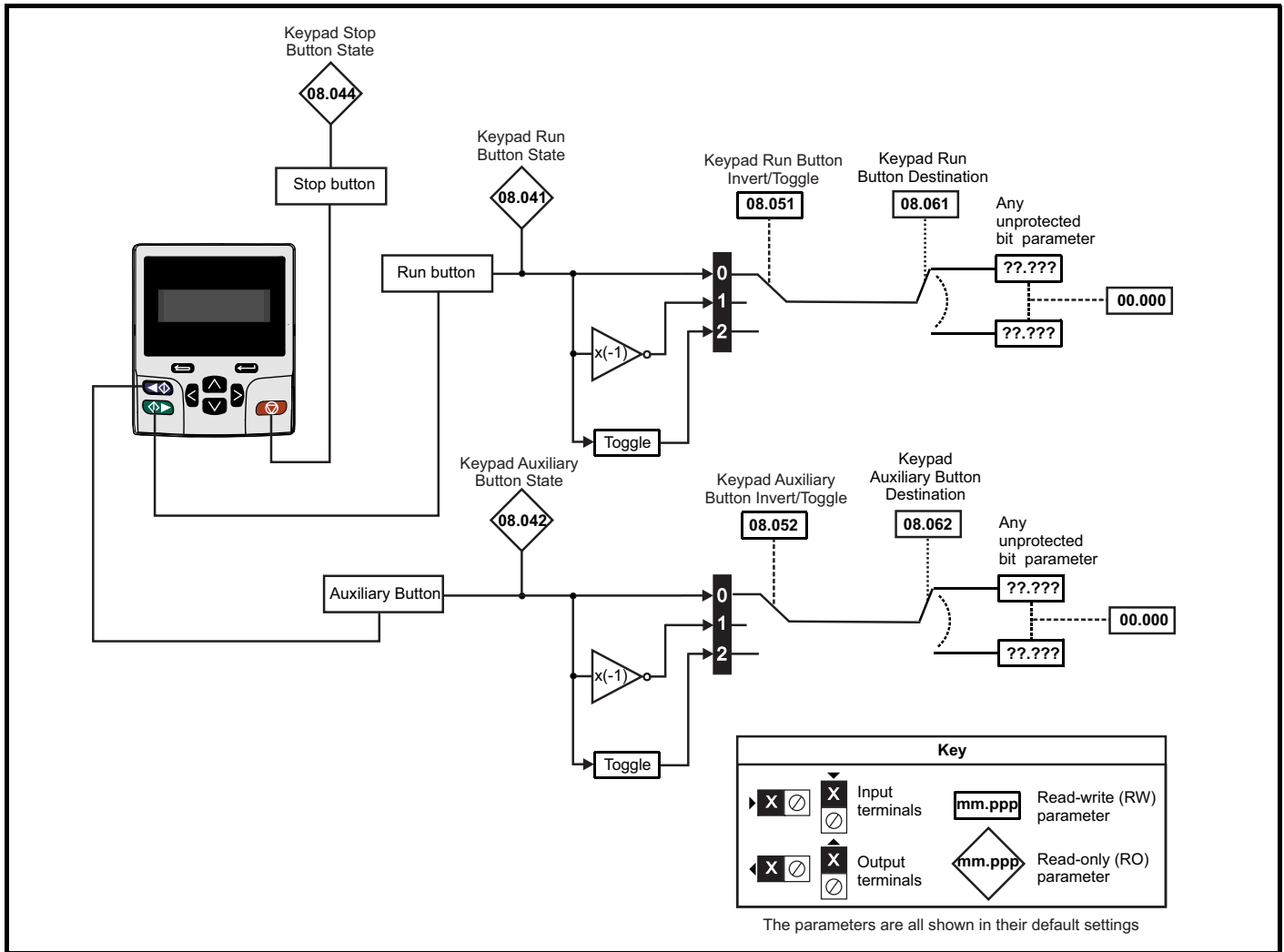

Figure 12-24 Menu 8 Keypad buttons logic diagram



Parameter		Range(⇅)		Default(⇒)			Type					
		OL	RFC-A / S	OL	RFC-A	RFC-S						
08.001	Digital I/O 01 State	Off (0) or On (1)					RO	Bit	ND	NC	PT	
08.002	Digital I/O 02 State	Off (0) or On (1)					RO	Bit	ND	NC	PT	
08.003	Digital I/O 03 State*	Off (0) or On (1)					RO	Bit	ND	NC	PT	
08.004	Digital Input 04 State	Off (0) or On (1)					RO	Bit	ND	NC	PT	
08.005	Digital Input 05 State	Off (0) or On (1)					RO	Bit	ND	NC	PT	
08.006	Digital Input 06 State*	Off (0) or On (1)					RO	Bit	ND	NC	PT	
08.007	Relay Output State	Off (0) or On (1)					RO	Bit	ND	NC	PT	
08.008	24V Supply Output State	Off (0) or On (1)					RO	Bit	ND	NC	PT	
08.009	STO Input 01 State	Off (0) or On (1)					RO	Bit	ND	NC	PT	
08.010	External Trip Mode	Disable (0), STO 1 (1), STO 2 (2), STO 1 OR STO 2 (3)		Disable (0)			RW	Txt				US
08.011	Digital I/O 01 Invert	Not Invert (0) or Invert (1)		Not Invert (0)			RW	Txt				US
08.012	Digital I/O 02 Invert	Not Invert (0) or Invert (1)		Not Invert (0)			RW	Txt				US
08.013	Digital I/O 03 Invert*	Not Invert (0) or Invert (1)		Not Invert (0)			RW	Txt				US
08.014	Digital Input 04 Invert	Not Invert (0) or Invert (1)		Not Invert (0)			RW	Txt				US
08.015	Digital Input 05 Invert	Not Invert (0) or Invert (1)		Not Invert (0)			RW	Txt				US
08.016	Digital Input 06 Invert*	Not Invert (0) or Invert (1)		Not Invert (0)			RW	Txt				US
08.017	Relay Invert	Not Invert (0) or Invert (1)		Not Invert (0)			RW	Txt				US
08.018	24V Supply Output Invert	Not Invert (0) or Invert (1)		Invert (1)			RW	Txt				US
08.020	Digital I/O Read Word	0 to 511					RO	Num	ND	NC	PT	
08.021	Digital I/O 01 Source/Destination	0.000 to 59.999		10.003			RW	Num	DE		PT	US
08.022	Digital I/O 02 Source/Destination	0.000 to 59.999		10.033**			RW	Num	DE		PT	US
08.023	Digital I/O 03 Source/Destination*	0.000 to 59.999		6.030			RW	Num	DE		PT	US
08.024	Digital Input 04 Destination	0.000 to 59.999		6.032***			RW	Num	DE		PT	US
08.025	Digital Input 05 Destination	0.000 to 59.999		1.041****			RW	Num	DE		PT	US
08.026	Digital Input 06 Destination*	0.000 to 59.999		6.031			RW	Num	DE		PT	US
08.027	Relay Output Source	0.000 to 59.999		10.001			RW	Num			PT	US
08.028	24V Supply Output Source	0.000 to 59.999		0.000			RW	Num			PT	US
08.029	Input Logic Polarity	Negative Logic (0) or Positive Logic (1)		Positive Logic (1)			RW	Txt				US
08.031	Digital I/O 01 Output Select*	Off (0) or On (1)		On (1)			RW	Bit				US
08.032	Digital I/O 02 Output Select*	Off (0) or On (1)		Off (0)			RW	Bit				US
08.033	Digital I/O 03 Output Select*	Off (0) or On (1)		Off (0)			RW	Bit				US
08.040	STO Input 02 State	Off (0) or On (1)					RO	Bit	ND	NC	PT	
08.041	Keypad Run Button State	Off (0) or On (1)					RO	Bit	ND	NC	PT	
08.042	Keypad Auxiliary Button State	Off (0) or On (1)					RO	Bit	ND	NC	PT	
08.043	24V Supply Input State	Off (0) or On (1)					RO	Bit	ND	NC	PT	
08.044	Keypad Stop Button State	Off (0) or On (1)					RO	Bit	ND	NC	PT	
08.051	Keypad Run Button Invert/Toggle	Not Invert (0), Invert (1) or Toggle (2)		Not Invert (0)			RW	Txt				US
08.052	Keypad Auxiliary Button Invert/Toggle	Not Invert (0), Invert (1) or Toggle (2)		Not Invert (0)			RW	Txt				US
08.053	24V Supply Input Invert	Not Invert (0) or Invert (1)		Not Invert (0)			RW	Txt				US
08.061	Keypad Run Button Destination	0.000 to 59.999		0.000			RW	Num	DE		PT	US
08.062	Keypad Auxiliary Button Destination	0.000 to 59.999		0.000			RW	Num	DE		PT	US
08.063	24V Supply Input Destination	0.000 to 59.999		0.000			RW	Num	DE		PT	US
08.071	DI/O Output Enable Register 1	0000000000000000 to 1111111111111111		0000000000000000			RW	Bin			PT	US
08.072	DI/O Input Register 1	0000000000000000 to 1111111111111111					RO	Bin	ND	NC	PT	
08.073	DI/O Output Register 1	0000000000000000 to 1111111111111111		0000000000000000			RW	Bin			PT	

* Not available on Unidrive M702.

** 0.000 with Unidrive M702.

*** 06.030 with Unidrive M702.

**** 06.032 with Unidrive M702.

RW	Read / Write	RO	Read only	Num	Number parameter	Bit	Bit parameter	Txt	Text string	Bin	Binary parameter	FI	Filtered
ND	No default value	NC	Not copied	PT	Protected parameter	RA	Rating dependent	US	User save	PS	Power-down save	DE	Destination

12.10 Menu 9: Programmable logic, motorized pot, binary sum and timers

Figure 12-25 Menu 9 logic diagram: Programmable logic

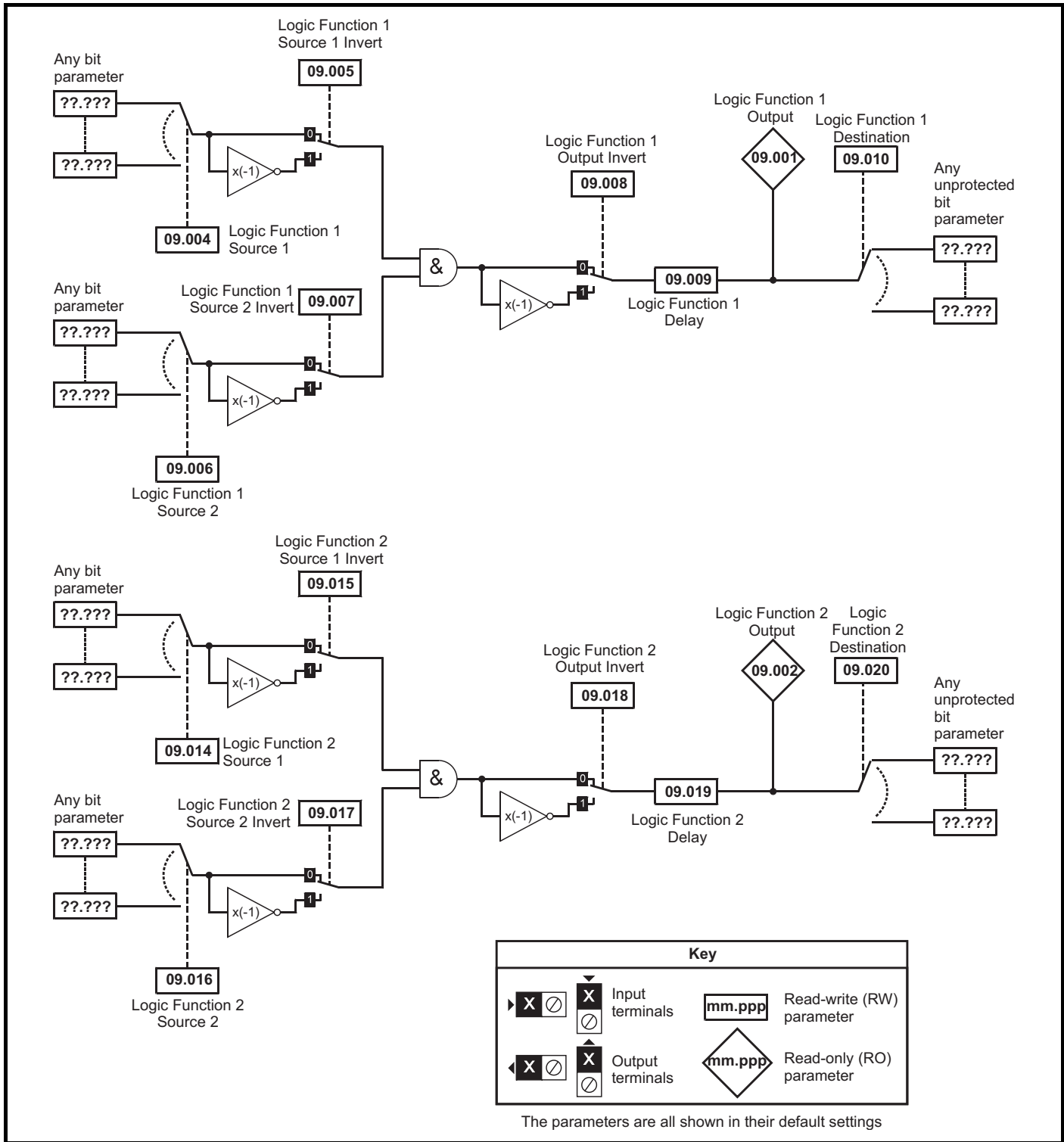

Figure 12-26 Menu 9 logic diagram: Motorized pot and binary sum

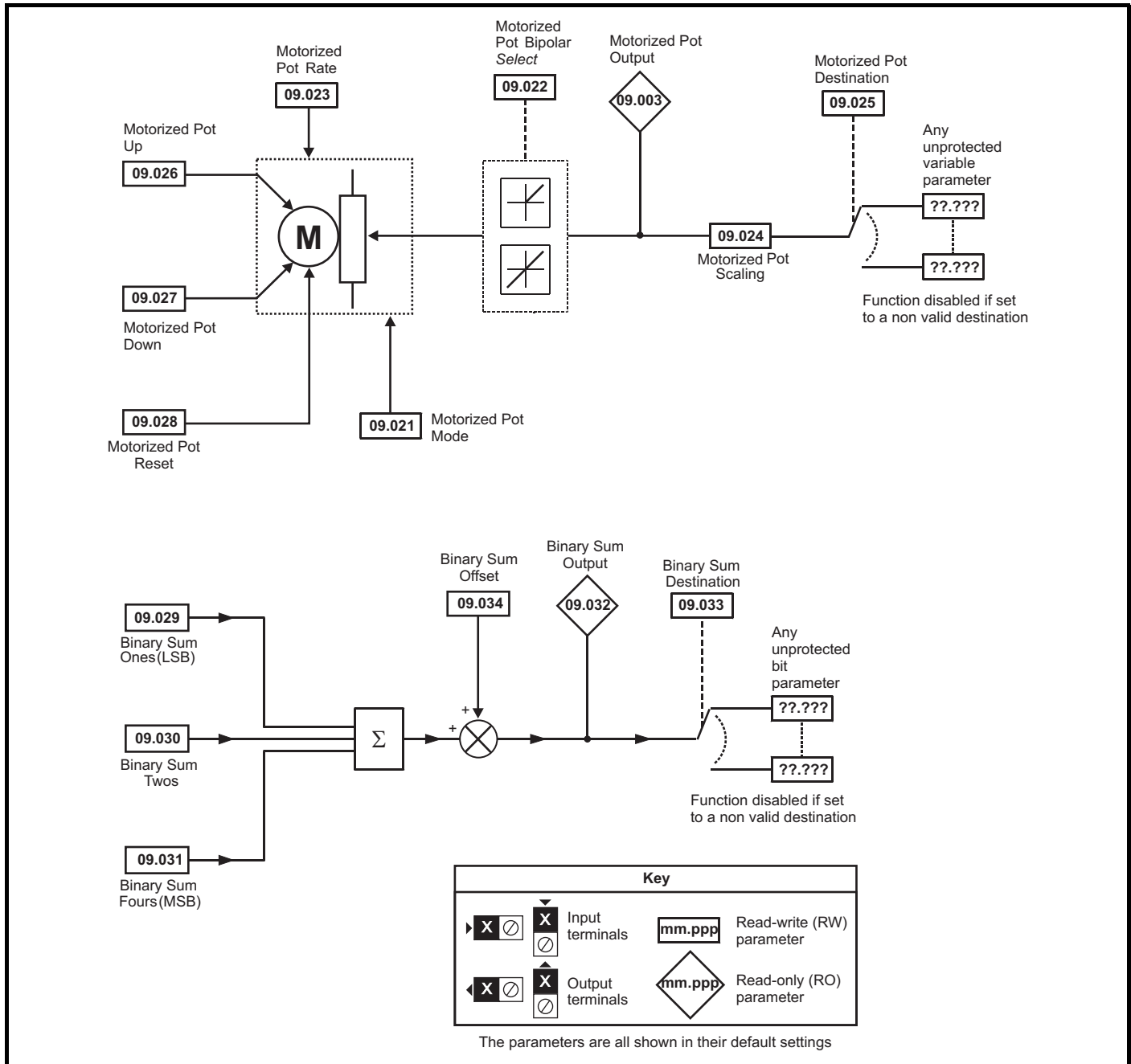

Figure 12-27 Menu 9 logic diagram: Timers

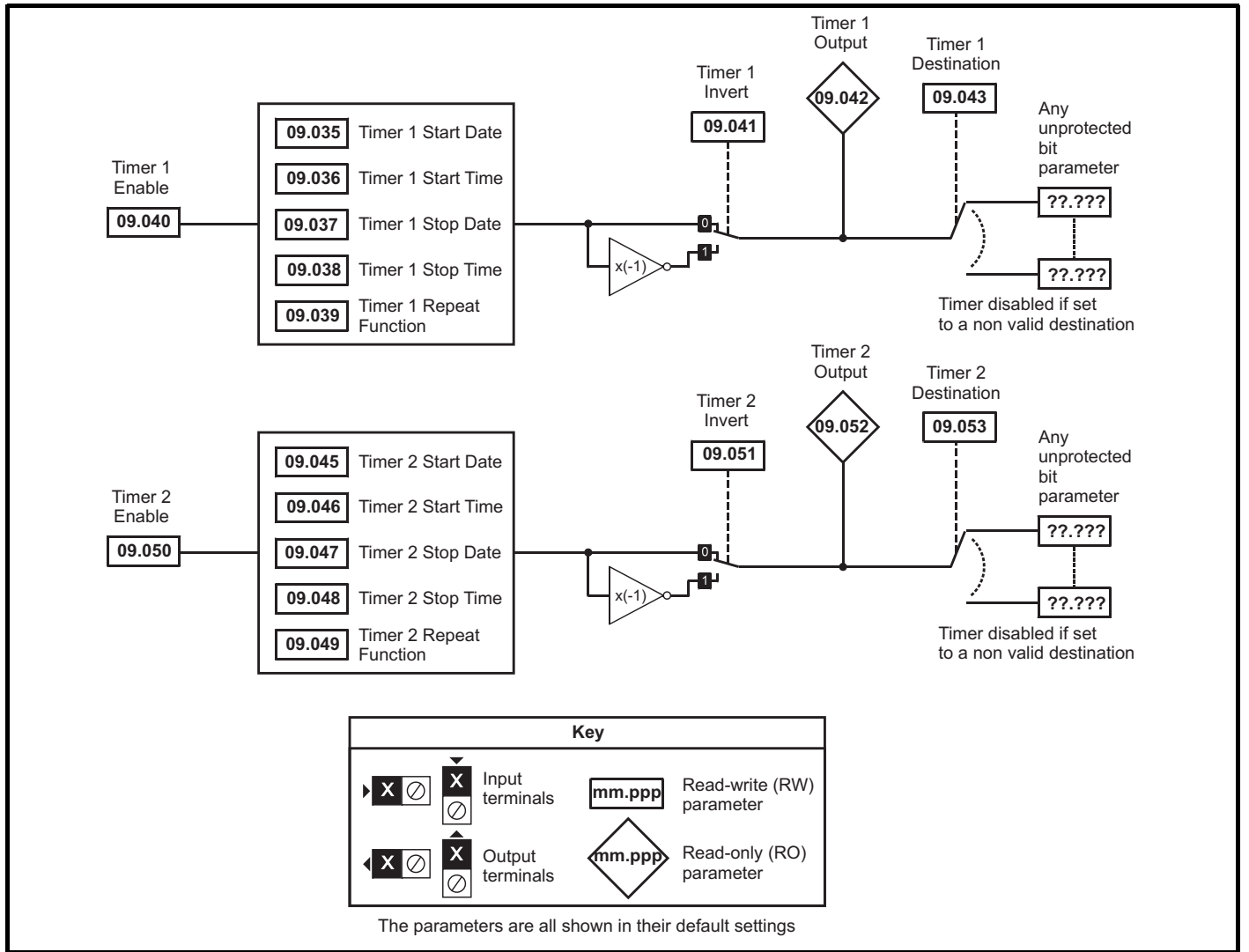
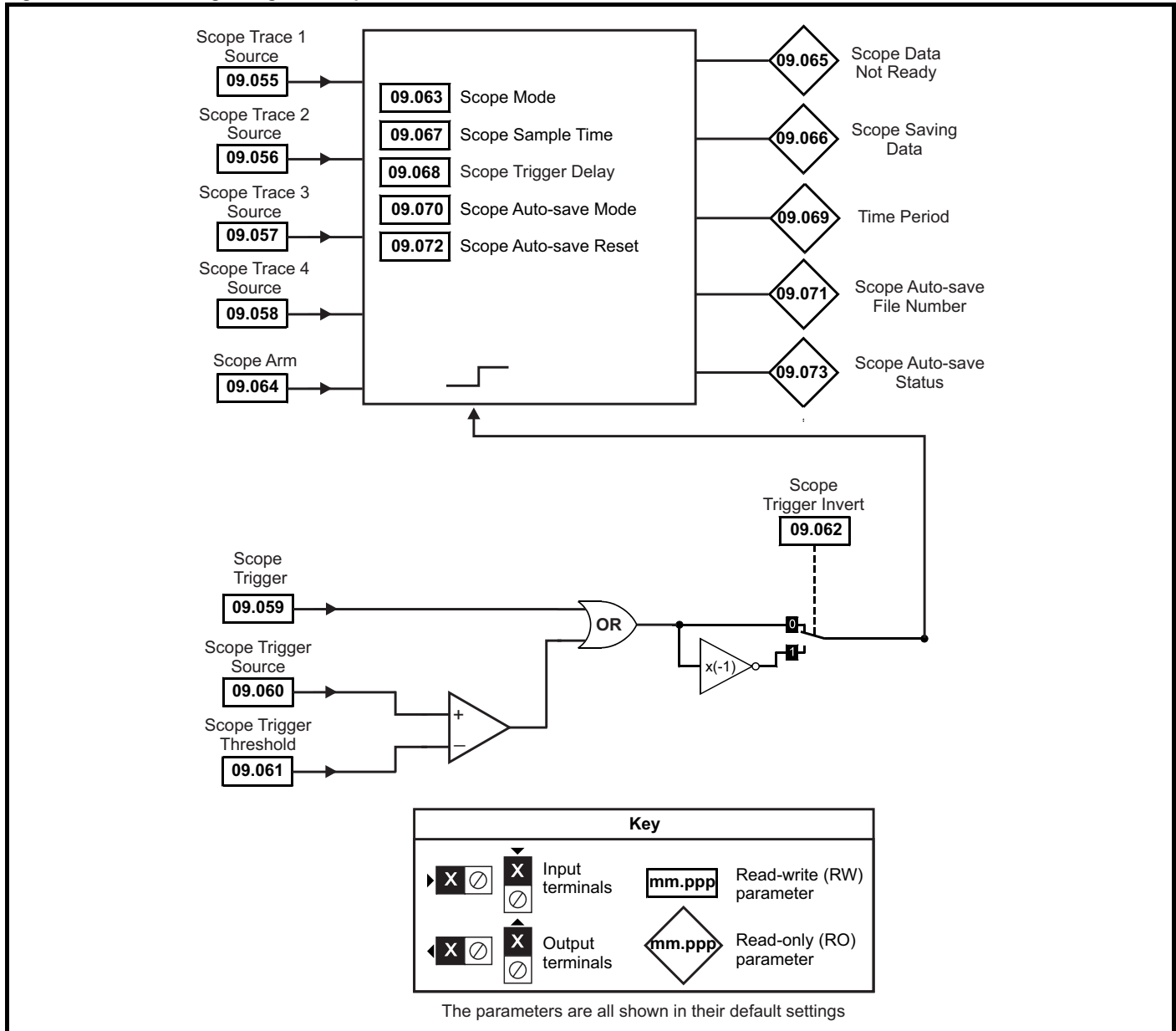

Figure 12-28 Menu 9 logic diagram: Scope function



Parameter	Range(ϕ)		Default(⇒)			Type					
	OL	RFC-A / S	OL	RFC-A	RFC-S						
09.001	Logic Function 1 Output	Off (0) or On (1)				RO	Bit	ND	NC	PT	
09.002	Logic Function 2 Output	Off (0) or On (1)				RO	Bit	ND	NC	PT	
09.003	Motorized Pot Output	±100.00 %				RO	Num	ND	NC	PT	PS
09.004	Logic Function 1 Source 1	0.000 to 59.999			0.000	RW	Num			PT	US
09.005	Logic Function 1 Source 1 Invert	Off (0) or On (1)			Off (0)	RW	Bit				US
09.006	Logic Function 1 Source 2	0.000 to 59.999			0.000	RW	Num			PT	US
09.007	Logic Function 1 Source 2 Invert	Off (0) or On (1)			Off (0)	RW	Bit				US
09.008	Logic Function 1 Output Invert	Off (0) or On (1)			Off (0)	RW	Bit				US
09.009	Logic Function 1 Delay	±25.0 s			0.0 s	RW	Num				US
09.010	Logic Function 1 Destination	0.000 to 59.999			0.000	RW	Num	DE		PT	US
09.014	Logic Function 2 Source 1	0.000 to 59.999			0.000	RW	Num			PT	US
09.015	Logic Function 2 Source 1 Invert	Off (0) or On (1)			Off (0)	RW	Bit				US
09.016	Logic Function 2 Source 2	0.000 to 59.999			0.000	RW	Num			PT	US
09.017	Logic Function 2 Source 2 Invert	Off (0) or On (1)			Off (0)	RW	Bit				US
09.018	Logic Function 2 Output Invert	Off (0) or On (1)			Off (0)	RW	Bit				US
09.019	Logic Function 2 Delay	±25.0 s			0.0 s	RW	Num				US
09.020	Logic Function 2 Destination	0.000 to 59.999			0.000	RW	Num	DE		PT	US
09.021	Motorized Pot Mode	0 to 4			0	RW	Num				US
09.022	Motorized Pot Bipolar Select	Off (0) or On (1)			Off (0)	RW	Bit				US
09.023	Motorized Pot Rate	0 to 250 s			20 s	RW	Num				US
09.024	Motorized Pot Scaling	0.000 to 4.000			1.000	RW	Num				US
09.025	Motorized Pot Destination	0.000 to 59.999			0.000	RW	Num	DE		PT	US
09.026	Motorized Pot Up	Off (0) or On (1)			Off (0)	RW	Bit		NC		
09.027	Motorized Pot Down	Off (0) or On (1)			Off (0)	RW	Bit		NC		
09.028	Motorized Pot Reset	Off (0) or On (1)			Off (0)	RW	Bit		NC		
09.029	Binary Sum Ones	Off (0) or On (1)			Off (0)	RW	Bit		NC		
09.030	Binary Sum Twos	Off (0) or On (1)			Off (0)	RW	Bit		NC		
09.031	Binary Sum Fours	Off (0) or On (1)			Off (0)	RW	Bit		NC		
09.032	Binary Sum Output	0 to 255				RO	Num	ND	NC	PT	
09.033	Binary Sum Destination	0.000 to 59.999			0.000	RW	Num	DE		PT	US
09.034	Binary Sum Offset	0 to 248			0	RW	Num				US
09.035	Timer 1 Start Date	00-00-00 to 31-12-99			00-00-00	RW	Date				US
09.036	Timer 1 Start Time	00:00:00 to 23:59:59			00:00:00	RW	Time				US
09.037	Timer 1 Stop Date	00-00-00 to 31-12-99			00-00-00	RW	Date				US
09.038	Timer 1 Stop Time	00:00:00 to 23:59:59			00:00:00	RW	Time				US
09.039	Timer 1 Repeat Function	None (0), Hour (1), Day (2), Week (3), Month (4), Year (5), One off (6), Minute (7)			None (0)	RW	Txt				US
09.040	Timer 1 Enable	Off (0) or On (1)			Off (0)	RW	Bit				US
09.041	Timer 1 Invert	Off (0) or On (1)			Off (0)	RW	Bit				US
09.042	Timer 1 Output	Off (0) or On (1)				RO	Bit	ND	NC	PT	
09.043	Timer 1 Destination	0.000 to 59.999			0.000	RW	Num	DE		PT	US
09.045	Timer 2 Start Date	00-00-00 to 31-12-99			00-00-00	RW	Date				US
09.046	Timer 2 Start Time	00:00:00 to 23:59:59			00:00:00	RW	Time				US
09.047	Timer 2 Stop Date	00-00-00 to 31-12-99			00-00-00	RW	Date				US
09.048	Timer 2 Stop Time	00:00:00 to 23:59:59			00:00:00	RW	Time				US
09.049	Timer 2 Repeat Function	None (0), Hour (1), Day (2), Week (3), Month (4), Year (5), One off (6), Minute (7)			None (0)	RW	Txt				US
09.050	Timer 2 Enable	Off (0) or On (1)			Off (0)	RW	Bit				US
09.051	Timer 2 Invert	Off (0) or On (1)			Off (0)	RW	Bit				US
09.052	Timer 2 Output	Off (0) or On (1)				RO	Bit	ND	NC	PT	
09.053	Timer 2 Destination	0.000 to 59.999			0.000	RW	Num	DE		PT	US
09.055	Scope Trace 1 Source	0.000 to 59.999			0.000	RW	Num			PT	US
09.056	Scope Trace 2 Source	0.000 to 59.999			0.000	RW	Num			PT	US
09.057	Scope Trace 3 Source	0.000 to 59.999			0.000	RW	Num			PT	US
09.058	Scope Trace 4 Source	0.000 to 59.999			0.000	RW	Num			PT	US
09.059	Scope Trigger	Off (0) or On (1)			Off (0)	RW	Bit				
09.060	Scope Trigger Source	0.000 to 59.999			0.000	RW	Num			PT	US
09.061	Scope Trigger Threshold	-2147483648 to 2147483647			0	RW	Num				US
09.062	Scope Trigger Invert	Off (0) or On (1)			Off (0)	RW	Bit				US

Parameter		Range(⇅)		Default(⇄)			Type						
		OL	RFC-A / S	OL	RFC-A	RFC-S							
09.063	Scope Mode	Single (0), Normal (1), Auto (2)		Single (0)			RW	Txt					US
09.064	Scope Arm	Off (0) or On (1)		Off (0)			RW	Bit		NC			
09.065	Scope Data Not Ready	Off (0) or On (1)					RO	Bit	ND	NC	PT		
09.066	Scope Saving Data	Off (0) or On (1)					RO	Bit	ND	NC	PT		
09.067	Scope Sample Time	1 to 200		1			RW	Num					US
09.068	Scope Trigger Delay	0 to 100 %		0 %			RW	Num					US
09.069	Scope Time Period	0.00 to 200000.00 ms					RO	Num	ND	NC	PT		
09.070	Scope Auto-save Mode	Disabled (0), Overwrite (1), Keep (2)		Disabled (0)			RW	Txt					US
09.071	Scope Auto-save File Number	0 to 99					RO	Num					PS
09.072	Scope Auto-save Reset	Off (0) or On (1)		Off (0)			RW	Bit					
09.073	Scope Auto-save Status	Disabled (0), Active (1), Stopped (2), Failed (3)					RO	Txt					PS

RW	Read / Write	RO	Read only	Num	Number parameter	Bit	Bit parameter	Txt	Text string	Bin	Binary parameter	FI	Filtered
ND	No default value	NC	Not copied	PT	Protected parameter	RA	Rating dependent	US	User save	PS	Power-down save	DE	Destination
IP	IP address	Mac	Mac address	Date	Date parameter	Time	Time parameter	SMP	Slot,menu,parameter	Chr	Character parameter	Ver	Version number

12.11 Menu 10: Status and trips

Parameter		Range(⊕)		Default(⇔)			Type					
		OL	RFC-A / S	OL	RFC-A	RFC-S						
10.001	Drive OK	Off (0) or On (1)					RO	Bit	ND	NC	PT	
10.002	Drive Active	Off (0) or On (1)					RO	Bit	ND	NC	PT	
10.003	Zero Speed	Off (0) or On (1)					RO	Bit	ND	NC	PT	
10.004	Running At Or Below Minimum Speed	Off (0) or On (1)					RO	Bit	ND	NC	PT	
10.005	Below Set Speed	Off (0) or On (1)					RO	Bit	ND	NC	PT	
10.006	At Speed	Off (0) or On (1)					RO	Bit	ND	NC	PT	
10.007	Above Set Speed	Off (0) or On (1)					RO	Bit	ND	NC	PT	
10.008	Rated Load Reached	Off (0) or On (1)					RO	Bit	ND	NC	PT	
10.009	Current Limit Active	Off (0) or On (1)					RO	Bit	ND	NC	PT	
10.010	Regenerating	Off (0) or On (1)					RO	Bit	ND	NC	PT	
10.011	Braking IGBT Active	Off (0) or On (1)					RO	Bit	ND	NC	PT	
10.012	Braking Resistor Alarm	Off (0) or On (1)					RO	Bit	ND	NC	PT	
10.013	Reverse Direction Commanded	Off (0) or On (1)					RO	Bit	ND	NC	PT	
10.014	Reverse Direction Running	Off (0) or On (1)					RO	Bit	ND	NC	PT	
10.015	Supply Loss	Off (0) or On (1)					RO	Bit	ND	NC	PT	
10.016	Under Voltage Active	Off (0) or On (1)					RO	Bit	ND	NC	PT	
10.017	Motor Overload Alarm	Off (0) or On (1)					RO	Bit	ND	NC	PT	
10.018	Drive Over-temperature Alarm	Off (0) or On (1)					RO	Bit	ND	NC	PT	
10.019	Drive Warning	Off (0) or On (1)					RO	Bit	ND	NC	PT	
10.020	Trip 0	0 to 255					RO	Txt	ND	NC	PT	PS
10.021	Trip 1	0 to 255					RO	Txt	ND	NC	PT	PS
10.022	Trip 2	0 to 255					RO	Txt	ND	NC	PT	PS
10.023	Trip 3	0 to 255					RO	Txt	ND	NC	PT	PS
10.024	Trip 4	0 to 255					RO	Txt	ND	NC	PT	PS
10.025	Trip 5	0 to 255					RO	Txt	ND	NC	PT	PS
10.026	Trip 6	0 to 255					RO	Txt	ND	NC	PT	PS
10.027	Trip 7	0 to 255					RO	Txt	ND	NC	PT	PS
10.028	Trip 8	0 to 255					RO	Txt	ND	NC	PT	PS
10.029	Trip 9	0 to 255					RO	Txt	ND	NC	PT	PS
10.030	Braking Resistor Rated Power	0.000 to 99999.999 kW				See Table 12-5	RW	Num				US
10.031	Braking Resistor Thermal Time Constant	0.000 to 1500.000 s				See Table 12-5	RW	Num				US
10.032	External Trip	Off (0) or On (1)				Off (0)	RW	Bit		NC		
10.033	Drive Reset	Off (0) or On (1)				Off (0)	RW	Bit		NC		
10.034	Number Of Auto-reset Attempts	None (0), 1 (1), 2 (2), 3 (3), 4 (4), 5 (5), Infinite (6)				None (0)	RW	Txt				US
10.035	Auto-reset Delay	1.0 to 600.0 s				1.0 s	RW	Num				US
10.036	Auto-reset Hold Drive ok	Off (0) or On (1)				Off (0)	RW	Bit				US
10.037	Action On Trip Detection	00000 to 11111				00000	RW	Bin				US
10.038	User Trip	0 to 255				0	RW	Num	ND	NC		
10.039	Braking Resistor Thermal Accumulator	0.0 to 100.0 %					RO	Num	ND	NC	PT	
10.040	Status Word	0000000000000000 to 1111111111111111					RO	Bin	ND	NC	PT	
10.041	Trip 0 Date	00-00-00 to 31-12-99					RO	Date	ND	NC	PT	PS
10.042	Trip 0 Time	00:00:00 to 23:59:59					RO	Time	ND	NC	PT	PS
10.043	Trip 1 Date	00-00-00 to 31-12-99					RO	Date	ND	NC	PT	PS
10.044	Trip 1 Time	00:00:00 to 23:59:59					RO	Time	ND	NC	PT	PS
10.045	Trip 2 Date	00-00-00 to 31-12-99					RO	Date	ND	NC	PT	PS
10.046	Trip 2 Time	00:00:00 to 23:59:59					RO	Time	ND	NC	PT	PS
10.047	Trip 3 Date	00-00-00 to 31-12-99					RO	Date	ND	NC	PT	PS
10.048	Trip 3 Time	00:00:00 to 23:59:59					RO	Time	ND	NC	PT	PS
10.049	Trip 4 Date	00-00-00 to 31-12-99					RO	Date	ND	NC	PT	PS
10.050	Trip 4 Time	00:00:00 to 23:59:59					RO	Time	ND	NC	PT	PS
10.051	Trip 5 Date	00-00-00 to 31-12-99					RO	Date	ND	NC	PT	PS
10.052	Trip 5 Time	00:00:00 to 23:59:59					RO	Time	ND	NC	PT	PS
10.053	Trip 6 Date	00-00-00 to 31-12-99					RO	Date	ND	NC	PT	PS
10.054	Trip 6 Time	00:00:00 to 23:59:59					RO	Time	ND	NC	PT	PS
10.055	Trip 7 Date	00-00-00 to 31-12-99					RO	Date	ND	NC	PT	PS
10.056	Trip 7 Time	00:00:00 to 23:59:59					RO	Time	ND	NC	PT	PS
10.057	Trip 8 Date	00-00-00 to 31-12-99					RO	Date	ND	NC	PT	PS

Parameter		Range(⇅)		Default(⇒)			Type					
		OL	RFC-A / S	OL	RFC-A	RFC-S						
10.058	Trip 8 Time	00:00:00 to 23:59:59					RO	Time	ND	NC	PT	PS
10.059	Trip 9 Date	00-00-00 to 31-12-99					RO	Date	ND	NC	PT	PS
10.060	Trip 9 Time	00:00:00 to 23:59:59					RO	Time	ND	NC	PT	PS
10.061	Braking Resistor Resistance	0.00 to 10000.00 Ω		See Table 12-5			RW	Num				US
10.062	Low Load Detected Alarm	Off (0) or On (1)					RO	Bit	ND	NC	PT	
10.063	Local Keypad Battery Low	Off (0) or On (1)					RO	Bit	ND	NC	PT	
10.064	Remote Keypad Battery Low	Off (0) or On (1)					RO	Bit	ND	NC	PT	
10.065	Auto-tune Active	Off (0) or On (1)					RO	Bit	ND	NC	PT	
10.066	Limit Switch Active	Off (0) or On (1)					RO	Bit	ND	NC	PT	
10.068	Hold Drive Healthy On Under Voltage	Off (0) or On (1)		Off (0)			RW	Bit				US
10.069	Additional Status Bits	0000000000 to 1111111111					RO	Bin	ND	NC	PT	
10.070	Trip 0 Sub-trip Number	0 to 65535					RO	Num	ND	NC	PT	PS
10.071	Trip 1 Sub-trip Number	0 to 65535					RO	Num	ND	NC	PT	PS
10.072	Trip 2 Sub-trip Number	0 to 65535					RO	Num	ND	NC	PT	PS
10.073	Trip 3 Sub-trip Number	0 to 65535					RO	Num	ND	NC	PT	PS
10.074	Trip 4 Sub-trip Number	0 to 65535					RO	Num	ND	NC	PT	PS
10.075	Trip 5 Sub-trip Number	0 to 65535					RO	Num	ND	NC	PT	PS
10.076	Trip 6 Sub-trip Number	0 to 65535					RO	Num	ND	NC	PT	PS
10.077	Trip 7 Sub-trip Number	0 to 65535					RO	Num	ND	NC	PT	PS
10.078	Trip 8 Sub-trip Number	0 to 65535					RO	Num	ND	NC	PT	PS
10.079	Trip 9 Sub-trip Number	0 to 65535					RO	Num	ND	NC	PT	PS
10.080	Stop Motor	Off (0) or On (1)					RO	Bit	ND	NC	PT	
10.081	Phase Loss	Off (0) or On (1)					RO	Bit	ND	NC	PT	
10.101	Drive Status	Inhibit (0), Ready (1), Stop (2), Scan (3), Run (4), Supply Loss (5), Deceleration (6), dc Injection (7), Position (8), Trip (9), Active (10), Off (11), Hand (12), Auto (13), Heat (14), Under Voltage (15), Phasing (16)					RO	Txt	ND	NC	PT	
10.102	Trip Reset Source	0 to 1023					RO	Num	ND	NC	PT	PS
10.103	Trip Time Identifier	-2147483648 to 2147483647 ms					RO	Num	ND	NC	PT	
10.104	Active Alarm	None (0), Brake Resistor (1), Motor Overload (2), Ind Overload (3), Drive Overload (4), Auto Tune (5), Limit Switch (6), Fire Mode (7), Low Load (8), Option Slot 1 (9), Option Slot 2 (10), Option Slot 3 (11), Option Slot 4 (12)					RO	Txt	ND	NC	PT	
10.105	Hand Off Auto State	Not Active (0), Off (1), Hand (2), Auto (3)					RO	Txt	ND	NC	PT	PS
10.106	Potential Drive Damage Conditions	0000 to 1111					RO	Bin	ND	NC	PT	PS
10.107	Auto tune State	Not Active (0), Resistance (1), pLs (2), Ls (3), Flux (4), Flux Repeat (5), Ld Lq No load (6), Lq (7), Ke (8), Inertia (9)					RO	Txt	ND	NC	PT	

RW	Read / Write	RO	Read only	Num	Number parameter	Bit	Bit parameter	Txt	Text string	Bin	Binary parameter	Fl	Filtered
ND	No default value	NC	Not copied	PT	Protected parameter	RA	Rating dependent	US	User save	PS	Power-down save	DE	Destination
IP	IP address	Mac	Mac address	Date	Date parameter	Time	Time parameter	SMP	Slot,menu,parameter	Chr	Character parameter	Ver	Version number

Table 12-5 Defaults for Pr 10.030, Pr 10.031 and Pr 10.061

Drive size	Pr 10.030	Pr 10.031	Pr 10.061
Size 3	50 W	3.3 s	75 Ω
Size 4 and 5	100 W	2.0 s	38 Ω
All other ratings and frame sizes	0.000		0.00

12.12 Menu 11: General drive set-up

Parameter	Range(⊕)		Default(⇌)			Type						
	OL	RFC-A / S	OL	RFC-A	RFC-S							
11.001	Option Synchronisation Select	Not Active (0), Slot 1 (1), Slot 2 (2), Slot 3 (3), Slot 4 (4), Automatic (5)	Slot 4 (4)			RW	Txt					US
11.002	Option synchronisation Active	Not Active (0), Slot 1 (1), Slot 2 (2), Slot 3 (3), Slot 4 (4)				RO	Txt	ND	NC	PT		
11.018	Status Mode Parameter 1	0.000 to 59.999	0.000			RW	Num			PT	US	
11.019	Status Mode Parameter 2	0.000 to 59.999	0.000			RW	Num			PT	US	
11.020	Reset Serial Communications*	Off (0) or On (1)	Off (0)			RW	Bit	ND	NC			
11.021	Parameter 00.030 Scaling	0.000 to 10.000	1.000			RW	Num				US	
11.022	Parameter Displayed At Power-up	0.000 to 0.080	0.010			RW	Num			PT	US	
11.023	Serial Address*	1 to 247	1			RW	Num				US	
11.024	Serial Mode*	8 2 NP (0), 8 1 NP (1), 8 1 EP (2), 8 1 OP (3), 8 2 NP M (4), 8 1 NP M (5), 8 1 EP M (6), 8 1 OP M (7), 7 2 NP (8), 7 1 NP (9), 7 1 EP (10), 7 1 OP (11), 7 2 NP M (12), 7 1 NP M (13), 7 1 EP M (14), 7 1 OP M (15)	8 2 NP (0)			RW	Txt					US
11.025	Serial Baud Rate*	300 (0), 600 (1), 1200 (2), 2400 (3), 4800 (4), 9600 (5), 19200 (6), 38400 (7), 57600 (8), 76800 (9), 115200 (10)	19200 (6)			RW	Txt					US
11.026	Minimum Comms Transmit Delay*	0 to 250 ms	2 ms			RW	Num				US	
11.027	Silent Period*	0 to 250 ms	0 ms			RW	Num				US	
11.028	Drive Derivative	0 to 255				RO	Num	ND	NC	PT		
11.029	Software Version	00.00.00.00 to 99.99.99.99				RO	Num	ND	NC	PT		
11.030	User Security Code	0 to 2147483647	0			RW	Num	ND	NC	PT	US	
11.031	User Drive Mode	Open-loop (1), RFC-A (2), RFC-S (3), Regen (4)	Open-loop (1)	RFC-A (2)	RFC-S (3)	RW	Txt	ND	NC	PT		
11.032	Maximum Heavy Duty Rating	0.000 to 99999.999 A				RO	Num	ND	NC	PT		
11.033	Drive Rated Voltage	200 V (0), 400 V (1), 575 V (2), 690 V (3)				RO	Txt	ND	NC	PT		
11.034	Software Sub Version	0 to 99				RO	Num	ND	NC	PT		
11.035	Number Of Power Modules Test	-1 to 20	-1			RW	Num				US	
11.036	NV Media Card File Previously Loaded	0 to 999				RO	Num		NC	PT		
11.037	NV Media Card File Number	0 to 999	0			RW	Num					
11.038	NV Media Card File Type	None (0), Open-loop (1), RFC-A (2), RFC-S (3), Regen (4), User Prog (5)				RO	Txt	ND	NC	PT		
11.039	NV Media Card File Version	0 to 9999				RO	Num	ND	NC	PT		
11.040	NV Media Card File Checksum	--2147483648 to 2147483647				RO	Num	ND	NC	PT		
11.042	Parameter Cloning	None (0), Read (1), Program (2), Auto (3), Boot (4)	None (0)			RW	Txt		NC		US	
11.043	Load Defaults	None (0), Standard (1), US (2)	None (0)			RW	Txt		NC			
11.044	User Security Status	Menu 0 (0), All Menus (1), Read-only Menu 0 (2), Read-only (3), Status Only (4), No Access (5)	Menu 0 (0)			RW	Txt	ND		PT		
11.045	Select Motor 2 Parameters	Motor 1 (0) or Motor 2 (1)	Motor 1 (0)			RW	Txt				US	
11.046	Defaults Previously Loaded	0 to 2000				RO	Num	ND	NC	PT	US	
11.047	Onboard User Program: Enable	Reset And Run (-1), Stop (0), Run (1)	Run (1)			RW	Txt				US	
11.048	Onboard User Program: Status	-2147483648 to 2147483647				RO	Num	ND	NC	PT		
11.049	Onboard User Program: Programming Events	0 to 65535				RO	Num	ND	NC	PT		
11.050	Onboard User Program: Freewheeling Tasks Per Second	0 to 65535				RO	Num	ND	NC	PT		
11.051	Onboard User Program: Clock Task Time Used	0.0 to 100.0 %				RO	Num	ND	NC	PT		
11.052	Serial Number LS	000000000 to 999999999				RO	Num	ND	NC	PT		
11.053	Serial Number MS	0 to 999999999				RO	Num	ND	NC	PT		
11.054	Drive Date Code	0 to 65535				RO	Num	ND	NC	PT		
11.055	Onboard User Program: Clock Task Scheduled Interval	0 to 262140 ms				RO	Num	ND	NC	PT		
11.056	Option Slot Identifiers	1234 (0), 1243 (1), 1324 (2), 1342 (3), 1423 (4), 1432 (5), 4123 (6), 3124 (7), 4132 (8), 2134 (9), 3142 (10), 2143 (11), 3412 (12), 4312 (13), 2413 (14), 4213 (15), 2314 (16), 3214 (17), 2341 (18), 2431 (19), 3241 (20), 3421 (21), 4231 (22), 4321 (23)	1234 (0)			RW	Txt			PT		
11.060	Maximum Rated Current	0.000 to 99999.999 A				RO	Num	ND	NC	PT		
11.061	Full Scale Current Kc	0.000 to 99999.999 A				RO	Num	ND	NC	PT		
11.062	Power Board Software Version Number	0.00 to 99.99				RO	Num	ND	NC	PT		
11.063	Product Type	0 to 255				RO	Num	ND	NC	PT		
11.064	Product Identifier Characters	M700 / M701 / M702				RO	Chr	ND	NC	PT		
11.065	Drive Rating And Configuration	00000000 to 99999999				RO	Num	ND	NC	PT		
11.066	Power Stage Identifier	0 to 255				RO	Num	ND	NC	PT		
11.067	Control Board Identifier	0.000 to 65.535				RO	Num	ND	NC	PT		

Parameter	Range(↕)		Default(⇔)			Type						
	OL	RFC-A / S	OL	RFC-A	RFC-S							
11.068	Internal I/O Identifier	0 to 255				RO	Num	ND	NC	PT		
11.069	Position Feedback Interface Identifier	0 to 255				RO	Num	ND	NC	PT		
11.070	Core Parameter Database Version	0.00 to 99.99				RO	Num	ND	NC	PT		
11.071	Number Of Power Modules Detected	0 to 20				RO	Num	ND	NC	PT	US	
11.072	NV Media Card Create Special File	0 to 1			0	RW	Num		NC			
11.073	NV Media Card Type	None (0), SMART Card (1), SD Card (2)				RO	Txt	ND	NC	PT		
11.075	NV Media Card Read-only Flag	Off (0) or On (1)				RO	Bit	ND	NC	PT		
11.076	NV Media Card Warning Suppression Flag	Off (0) or On (1)				RO	Bit	ND	NC	PT		
11.077	NV Media Card File Required Version	0 to 9999			0	RW	Num	ND	NC	PT		
11.079	Drive Name Characters 1-4	---- (-2147483648) to --- (2147483647)			---- (0)	RW	Chr			PT	US	
11.080	Drive Name Characters 5-8	---- (-2147483648) to --- (2147483647)			---- (0)	RW	Chr			PT	US	
11.081	Drive Name Characters 9-12	---- (-2147483648) to --- (2147483647)			---- (0)	RW	Chr			PT	US	
11.082	Drive Name Characters 13-16	---- (-2147483648) to --- (2147483647)			---- (0)	RW	Chr			PT	US	
11.084	Drive Mode	Open-loop (1), RFC-A (2), RFC-S (3), Regen (4)				RO	Txt	ND	NC	PT	US	
11.085	Security Status	None (0), Read-only (1), Status-only (2), No Access (3)				RO	Txt	ND	NC	PT	PS	
11.086	Menu Access Status	Menu 0 (0) or All Menus (1)				RO	Txt	ND	NC	PT	PS	
11.090	Keypad Port Serial Address	1 to 16			1	RW	Num				US	
11.091	Additional Identifier Characters 1	---- (-2147483648) to --- (2147483647)				RO	Chr	ND	NC	PT		
11.092	Additional Identifier Characters 2	---- (-2147483648) to --- (2147483647)				RO	Chr	ND	NC	PT		
11.093	Additional Identifier Characters 3	---- (-2147483648) to --- (2147483647)				RO	Chr	ND	NC	PT		
11.095	Number Of Rectifiers Detected	0 to 9				RO	Num	ND	NC	PT		
11.096	Number Of Rectifiers Expected	0 to 9			0	RW	Num				US	

* On Unidrive M701 only.

RW	Read / Write	RO	Read only	Num	Number parameter	Bit	Bit parameter	Txt	Text string	Bin	Binary parameter	FI	Filtered
ND	No default value	NC	Not copied	PT	Protected parameter	RA	Rating dependent	US	User save	PS	Power-down save	DE	Destination
IP	IP address	Mac	Mac address	Date	Date parameter	Time	Time parameter	SMP	Slot,menu,parameter	Chr	Character parameter	Ver	Version number

12.13 Menu 12: Threshold detectors, variable selectors and brake control function

Figure 12-29 Menu 12 logic diagram

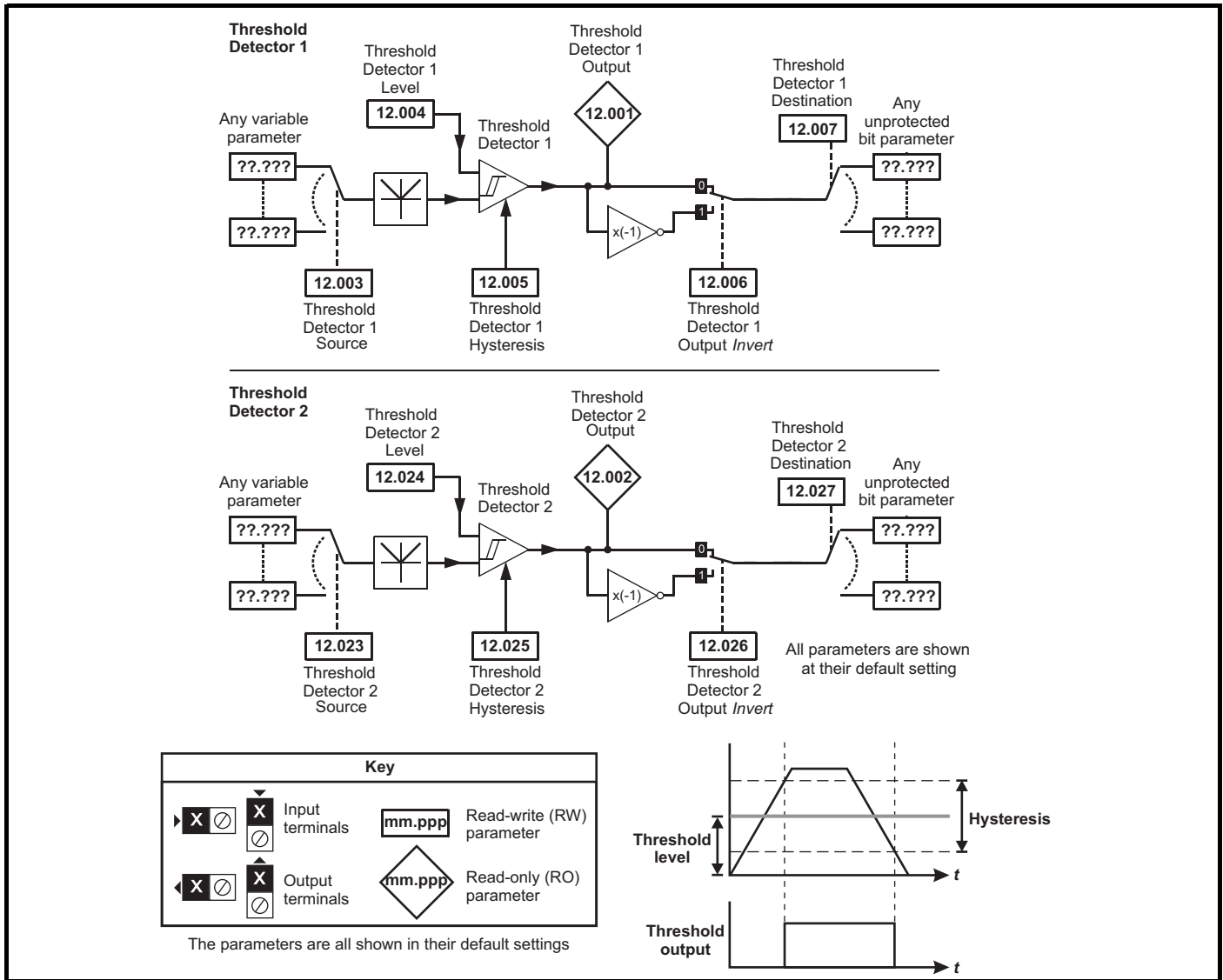
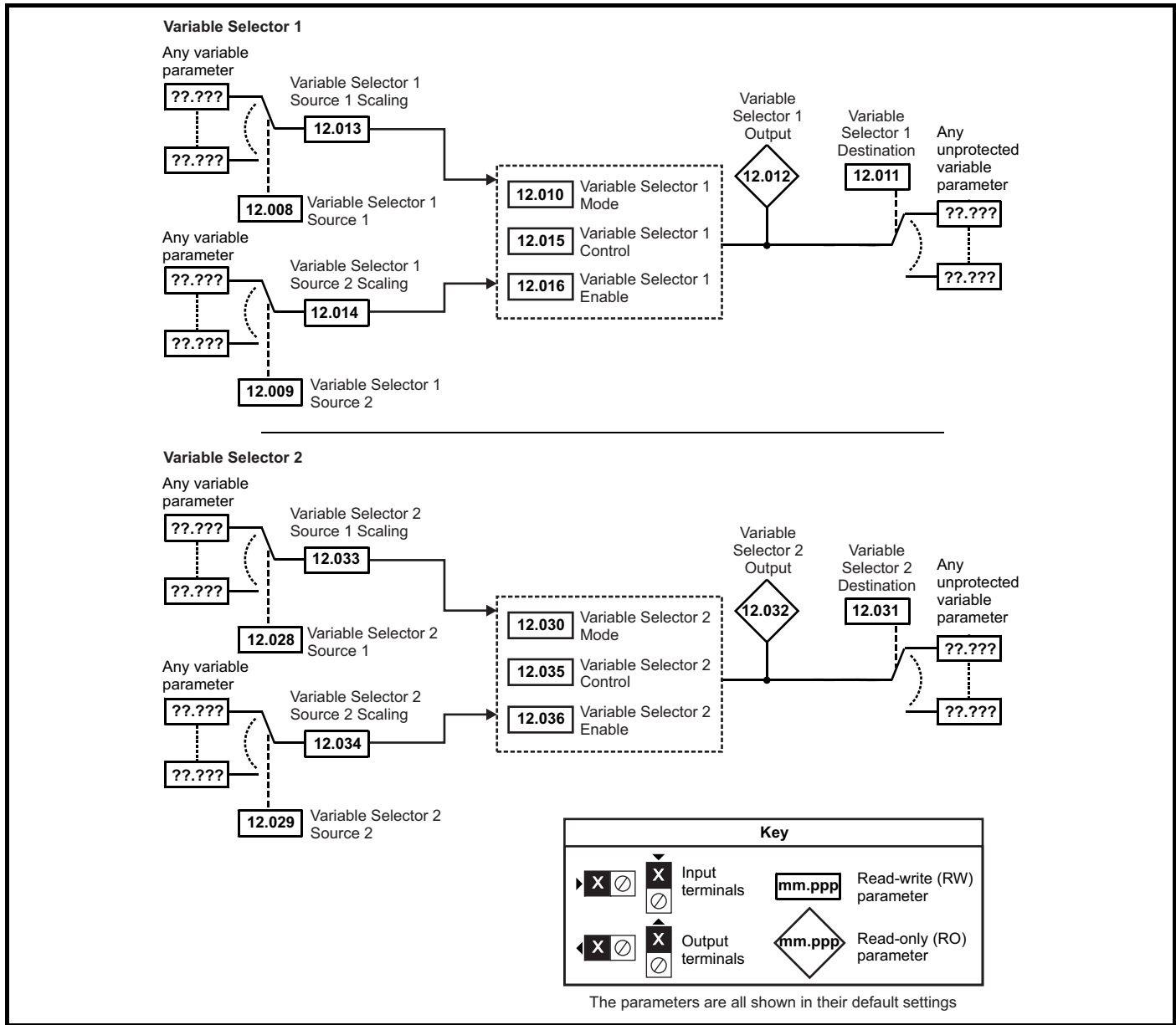

Figure 12-30 Menu 12 logic diagram (continued)





The brake control functions are provided to allow well co-ordinated operation of an external brake with the drive. While both hardware and software are designed to high standards of quality and robustness, they are not intended for use as safety functions, i.e. where a fault or failure would result in a risk of injury. In any application where the incorrect operation of the brake release mechanism could result in injury, independent protection devices of proven integrity must also be incorporated.



The control terminal relay can be selected as an output to release a brake. If a drive is set up in this manner and a drive replacement takes place, prior to programming the drive on initial power up, the brake may be released. When drive terminals are programmed to non default settings the result of incorrect or delayed programming must be considered. The use of a NV media card in boot mode or an SI-Applications module can ensure drive parameters are immediately programmed to avoid this situation.

Figure 12-31 Open-loop brake function

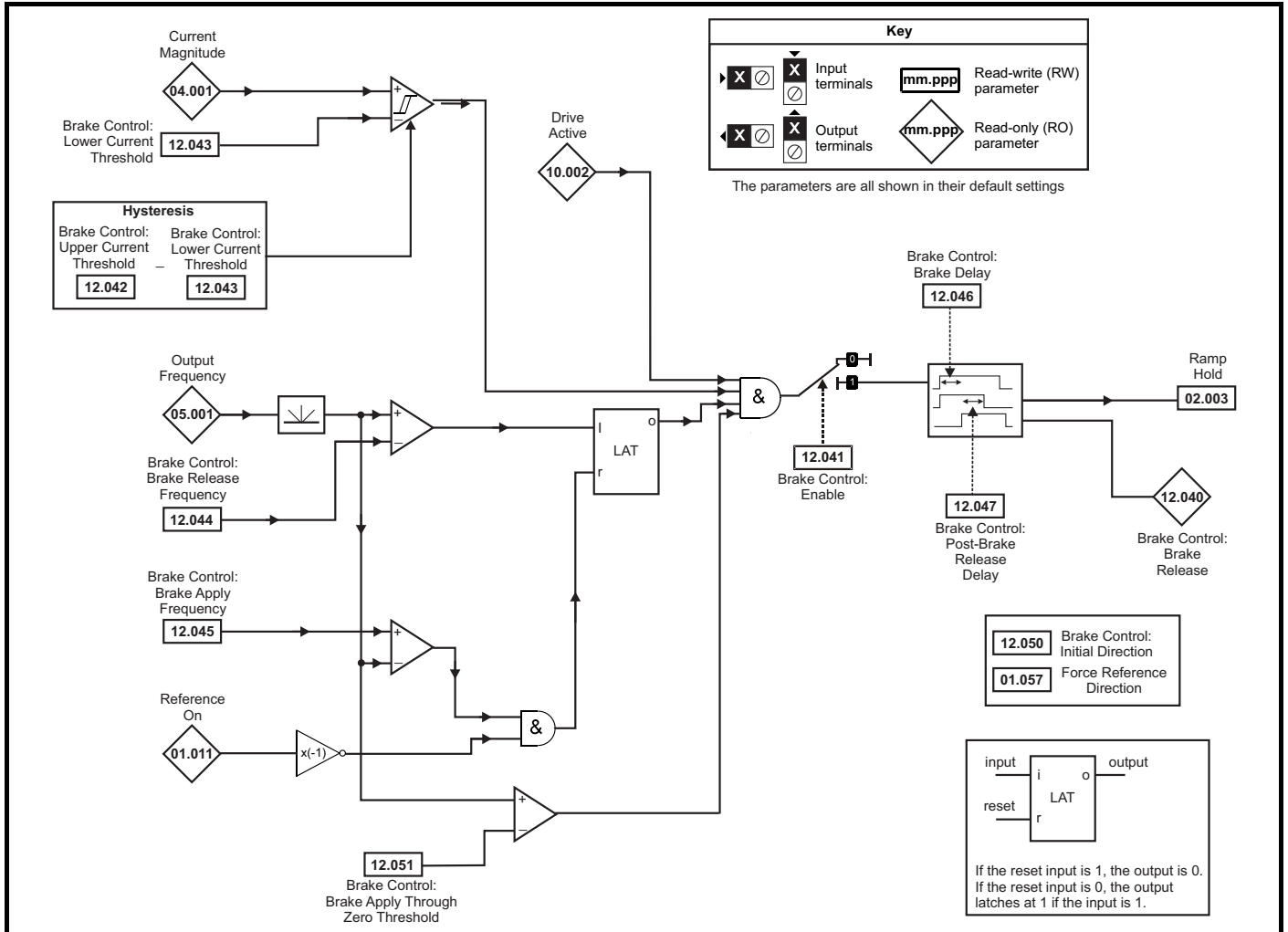
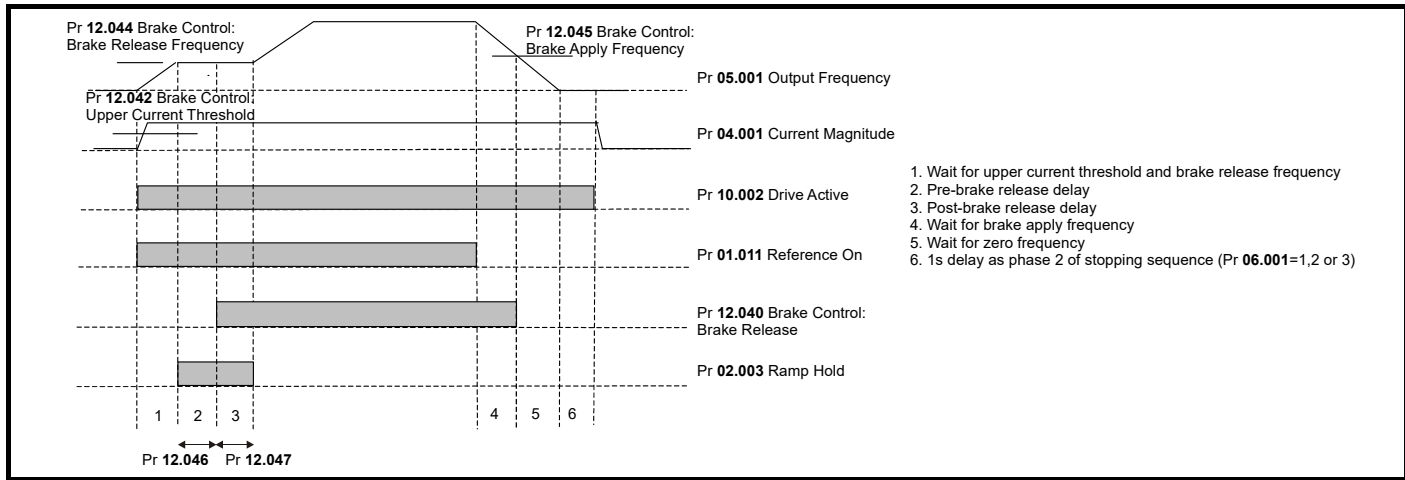

Figure 12-32 Open-loop brake sequence



The brake control functions are provided to allow well co-ordinated operation of an external brake with the drive. While both hardware and software are designed to high standards of quality and robustness, they are not intended for use as safety functions, i.e. where a fault or failure would result in a risk of injury. In any application where the incorrect operation of the brake release mechanism could result in injury, independent protection devices of proven integrity must also be incorporated.



The control terminal relay can be selected as an output to release a brake. If a drive is set up in this manner and a drive replacement takes place, prior to programming the drive on initial power up, the brake may be released. When drive terminals are programmed to non default settings the result of incorrect or delayed programming must be considered. The use of a NV media card in boot mode or an SI-Applications module can ensure drive parameters are immediately programmed to avoid this situation.

Figure 12-33 RFC-A mode with brake controller mode (12.052) =0 (RFC-A with position feedback mode)

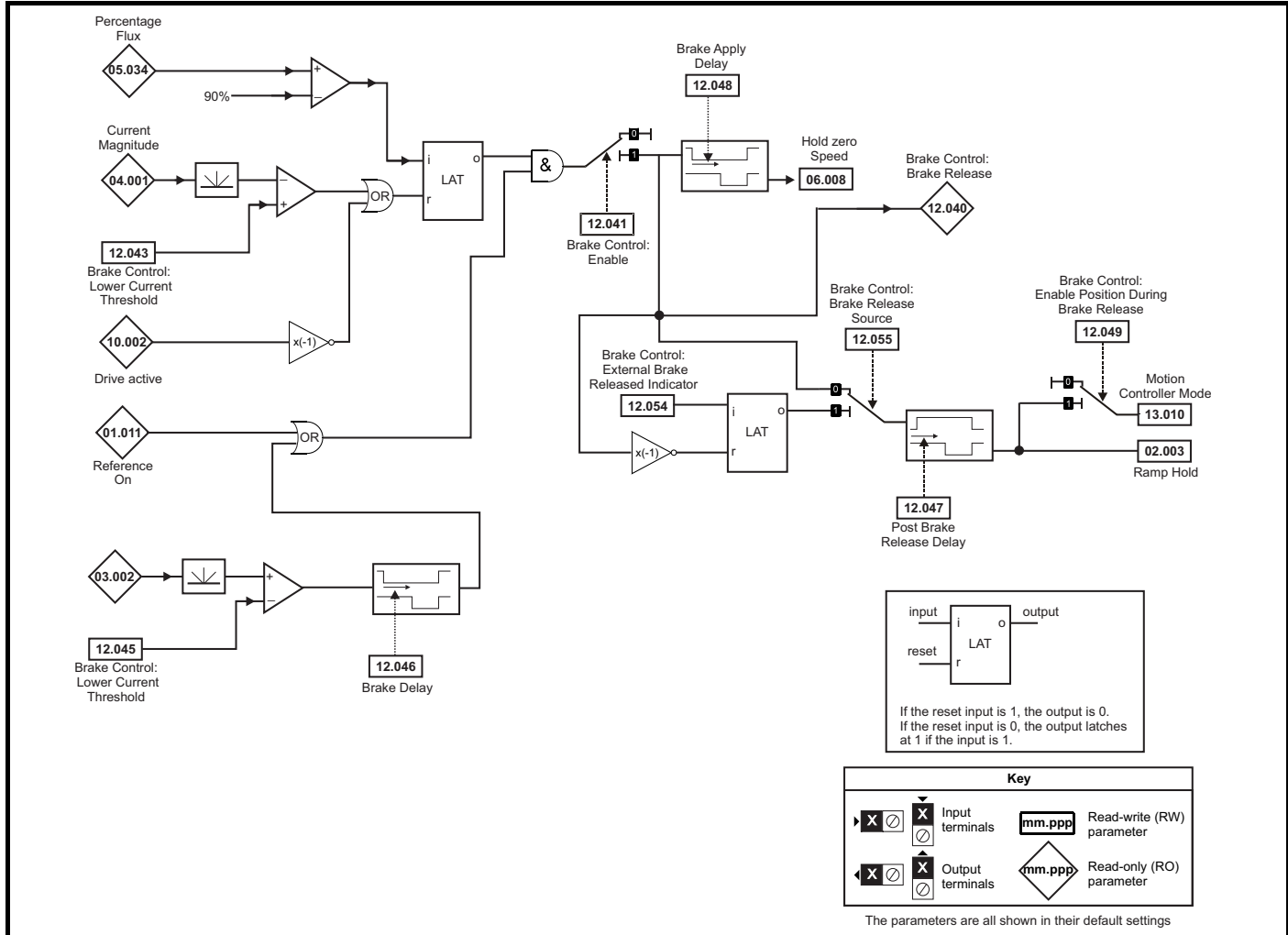
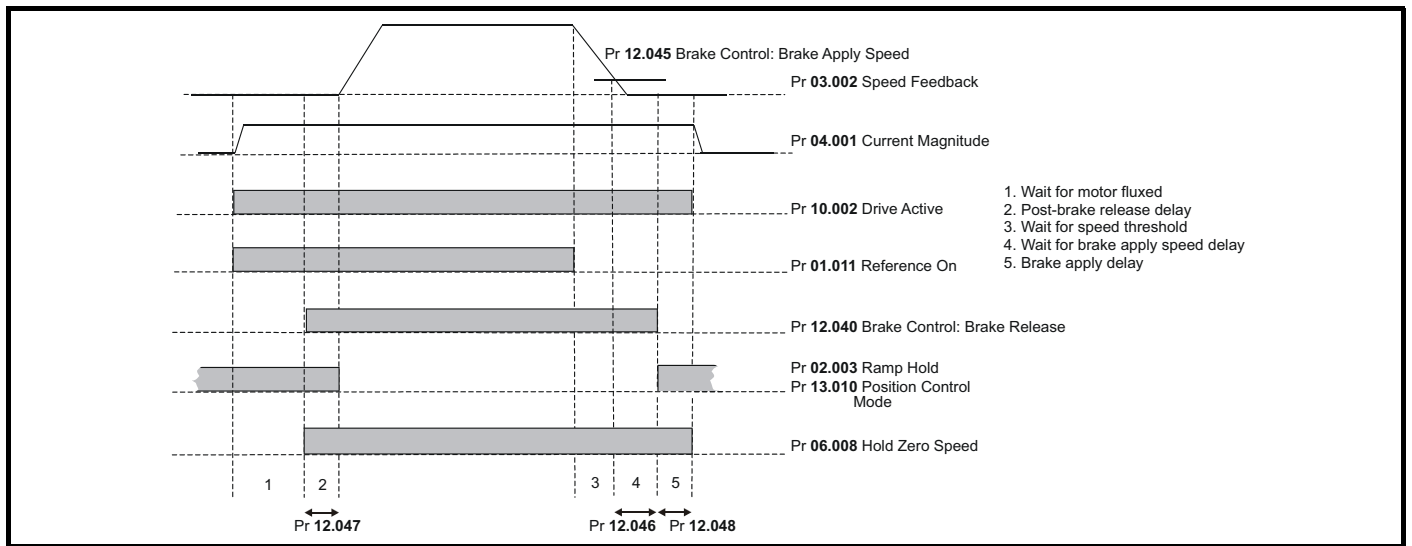

Figure 12-34 RFC-A with position feedback brake sequence



The brake control functions are provided to allow well co-ordinated operation of an external brake with the drive. While both hardware and software are designed to high standards of quality and robustness, they are not intended for use as safety functions, i.e. where a fault or failure would result in a risk of injury. In any application where the incorrect operation of the brake release mechanism could result in injury, independent protection devices of proven integrity must also be incorporated.



The control terminal relay can be selected as an output to release a brake. If a drive is set up in this manner and a drive replacement takes place, prior to programming the drive on initial power up, the brake may be released. When drive terminals are programmed to non default settings the result of incorrect or delayed programming must be considered. The use of a NV media card in boot mode or an SI-Applications module can ensure drive parameters are immediately programmed to avoid this situation.

Figure 12-35 RFC-A mode with brake controller mode (12.052) =1 (RFC-A Sensorless mode)

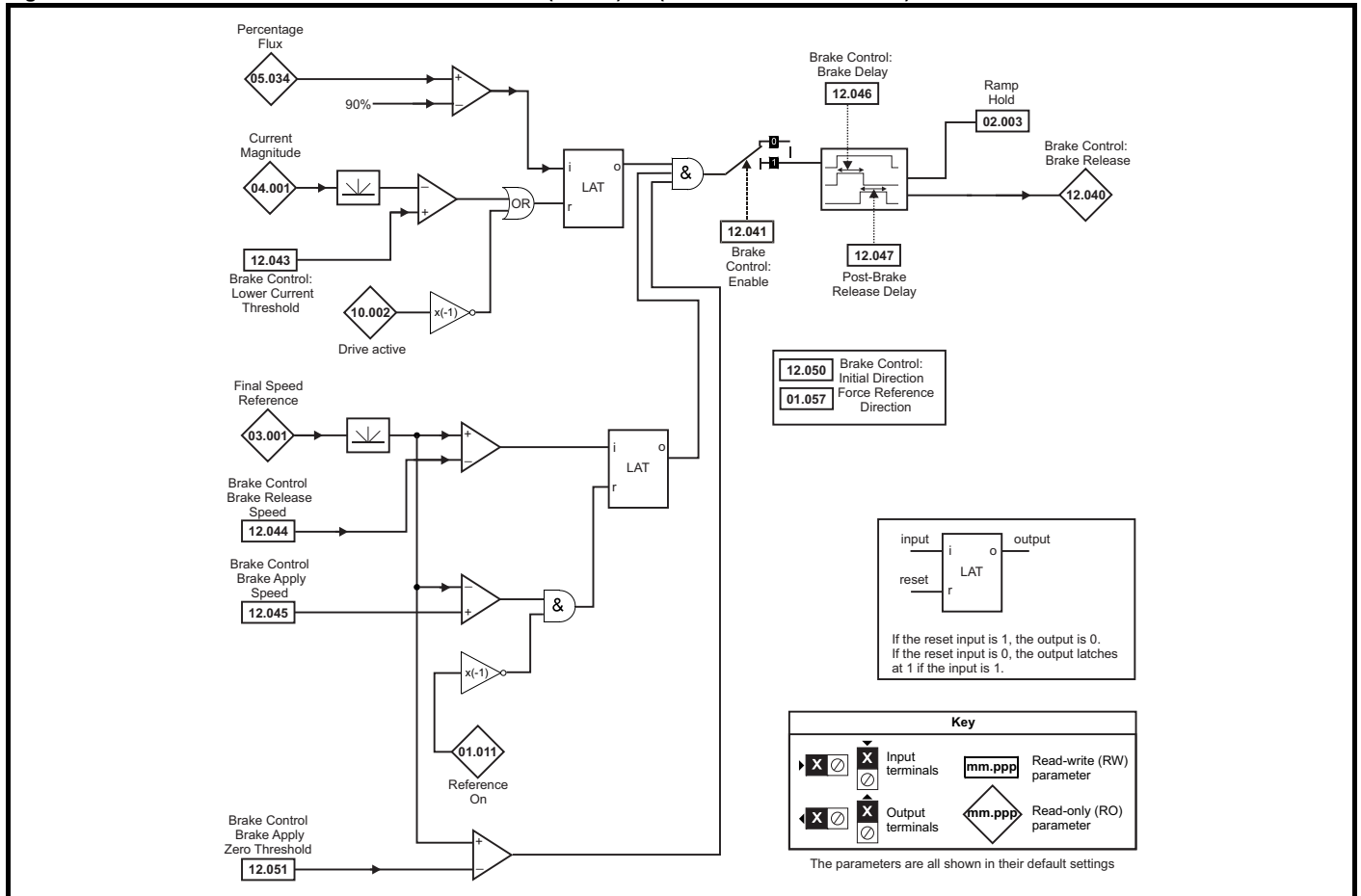



The brake control functions are provided to allow well co-ordinated operation of an external brake with the drive. While both hardware and software are designed to high standards of quality and robustness, they are not intended for use as safety functions, i.e. where a fault or failure would result in a risk of injury. In any application where the incorrect operation of the brake release mechanism could result in injury, independent protection devices of proven integrity must also be incorporated.



The control terminal relay can be selected as an output to release a brake. If a drive is set up in this manner and a drive replacement takes place, prior to programming the drive on initial power up, the brake may be released. When drive terminals are programmed to non default settings the result of incorrect or delayed programming must be considered. The use of a NV media card in boot mode or an SI-Applications module can ensure drive parameters are immediately programmed to avoid this situation.

Figure 12-36 RFC-S brake function

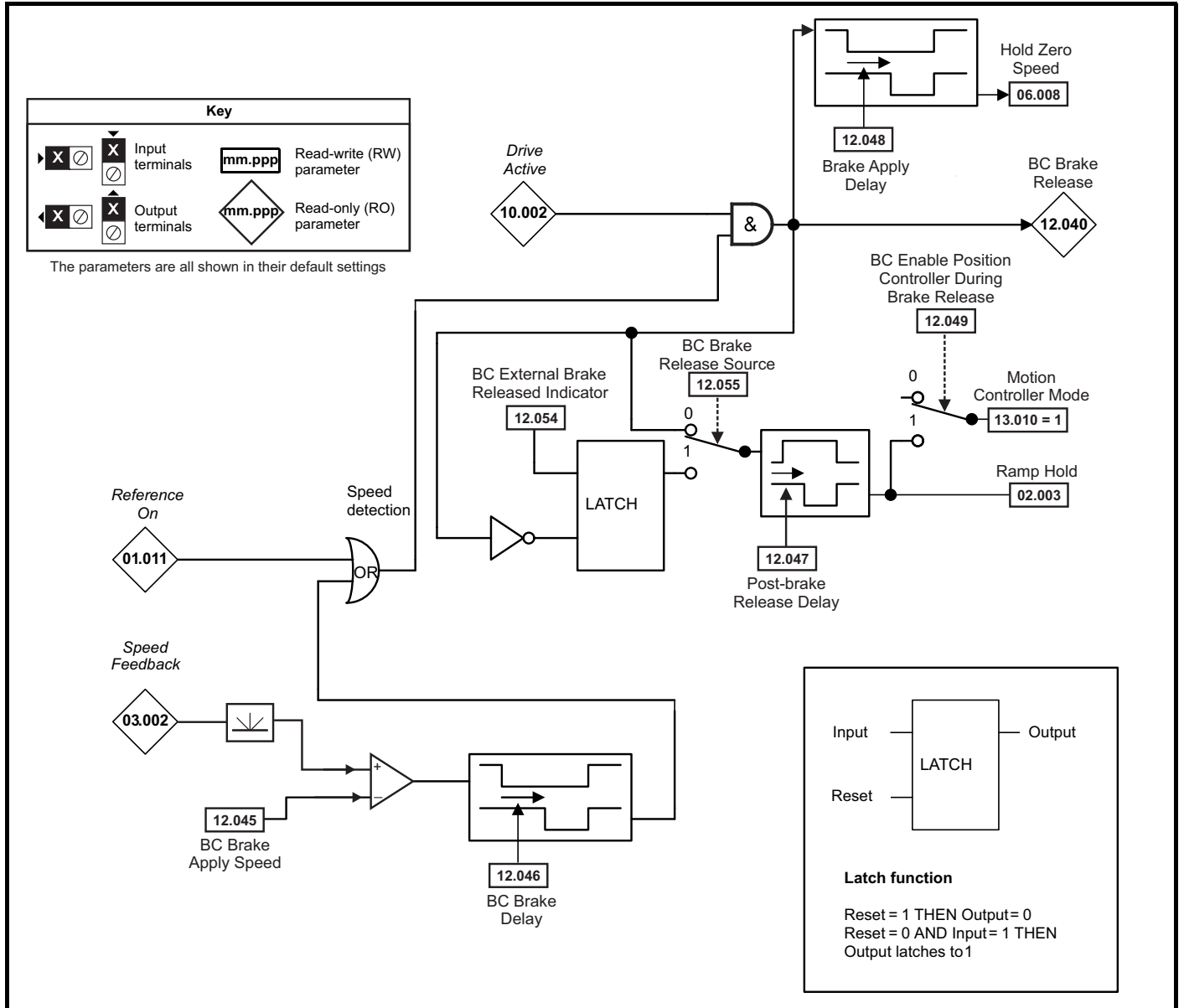

Parameter	Range(⊘)			Default(⇔)			Type					
	OL	RFC-A	RFC-S	OL	RFC-A	RFC-S	RO	Bit	ND	NC	PT	US
12.001	Threshold Detector 1 Output			Off (0) or On (1)			RO	Bit	ND	NC	PT	
12.002	Threshold Detector 2 Output			Off (0) or On (1)			RO	Bit	ND	NC	PT	
12.003	Threshold Detector 1 Source			0.000 to 59.999			RW	Num			PT	US
12.004	Threshold Detector 1 Level			0.00 to 100.00 %			RW	Num				US
12.005	Threshold Detector 1 Hysteresis			0.00 to 25.00 %			RW	Num				US
12.006	Threshold Detector 1 Output Invert			Off (0) or On (1)			RW	Bit				US
12.007	Threshold Detector 1 Destination			0.000 to 59.999			RW	Num	DE		PT	US
12.008	Variable Selector 1 Source 1			0.000 to 59.999			RW	Num			PT	US
12.009	Variable Selector 1 Source 2			0.000 to 59.999			RW	Num			PT	US
12.010	Variable Selector 1 Mode			Input 1 (0), Input 2 (1), Add (2), Subtract (3), Multiply (4), Divide (5), Time Const (6), Ramp (7), Modulus (8), Powers (9), Sectional (10)			RW	Txt				US
12.011	Variable Selector 1 Destination			0.000 to 59.999			RW	Num	DE		PT	US
12.012	Variable Selector 1 Output			±100.00 %			RO	Num	ND	NC	PT	
12.013	Variable Selector 1 Source 1 Scaling			±4.000			RW	Num				US
12.014	Variable Selector 1 Source 2 Scaling			±4.000			RW	Num				US
12.015	Variable Selector 1 Control			0.00 to 100.00			RW	Num				US
12.016	Variable Selector 1 Enable			Off (0) or On (1)			RW	Bit				US
12.023	Threshold Detector 2 Source			0.000 to 59.999			RW	Num			PT	US
12.024	Threshold Detector 2 Level			0.00 to 100.00 %			RW	Num				US
12.025	Threshold Detector 2 Hysteresis			0.00 to 25.00 %			RW	Num				US
12.026	Threshold Detector 2 Output Invert			Off (0) or On (1)			RW	Bit				US
12.027	Threshold Detector 2 Destination			0.000 to 59.999			RW	Num	DE		PT	US
12.028	Variable Selector 2 Source 1			0.000 to 59.999			RW	Num			PT	US
12.029	Variable Selector 2 Source 2			0.000 to 59.999			RW	Num			PT	US
12.030	Variable Selector 2 Mode			Input 1 (0), Input 2 (1), Add (2), Subtract (3), Multiply (4), Divide (5), Time Const (6), Ramp (7), Modulus (8), Powers (9), Sectional (10)			RW	Txt				US
12.031	Variable Selector 2 Destination			0.000 to 59.999			RW	Num	DE		PT	US
12.032	Variable Selector 2 Output			±100.00 %			RO	Num	ND	NC	PT	
12.033	Variable Selector 2 Source 1 Scaling			±4.000			RW	Num				US
12.034	Variable Selector 2 Source 2 Scaling			±4.000			RW	Num				US
12.035	Variable Selector 2 Control			0.00 to 100.00			RW	Num				US
12.036	Variable Selector 2 Enable			Off (0) or On (1)			RW	Bit				US
12.040	Brake Control: Brake Release			Off (0) or On (1)			RO	Bit	ND	NC	PT	
12.041	Brake Control: Enable			Off (0) or On (1)			RW	Bit				US
12.042	Brake Control: Upper Current Threshold		0 to 200 %	50 %		RW	Num					US
12.043	Brake Control: Lower Current Threshold		0 to 200 %			RW	Num					US
12.044	Brake Control: Brake Release Frequency		0.0 to 20.0 Hz	1.0 Hz		RW	Num					US
	Brake Control: Brake Release Speed		0 to 200 rpm	10 rpm		RW	Num					US
12.045	Brake Control: Brake Apply Frequency		0.0 to 20.0 Hz	2.0 Hz		RW	Num					US
	Brake Control: Brake Apply Speed		0 to 200 rpm			5 rpm		RW	Num			
12.046	Brake Control: Brake Delay			0.0 to 25.0 s			RW	Num				US
12.047	Brake Control: Post-brake Release Delay			0.0 to 25.0 s			RW	Num				US
12.048	Brake Control: Brake Apply Delay			0.0 to 25.0 s			RW	Num				US
12.049	Brake Control: Enable Position Control During Brake Release			Off (0) or On (1)			RW	Bit				US
12.050	Brake Control: Initial Direction			Ref (0), Forward (1), Reverse (2)			RW	Txt				US
12.051	Brake Control: Brake Apply Through Zero Threshold		0.0 to 20.0 Hz	0 to 200 rpm	1.0 Hz	5 rpm	RW	Num				US
12.052	Brake Control: Mode			Off (0) or On (1)			RW	Bit				US
12.054	External Brake Released Indicator			Off (0) or On (1)			RW	Bit				US
12.055	Brake Release Source			Off (0) or On (1)			RW	Bit				US

RW	Read / Write	RO	Read only	Num	Number parameter	Bit	Bit parameter	Txt	Text string	Bin	Binary parameter	FI	Filtered
ND	No default value	NC	Not copied	PT	Protected parameter	RA	Rating dependent	US	User save	PS	Power-down save	DE	Destination

12.14 Menu 13: Standard motion controller

Figure 12-37 Menu 13 logic diagram

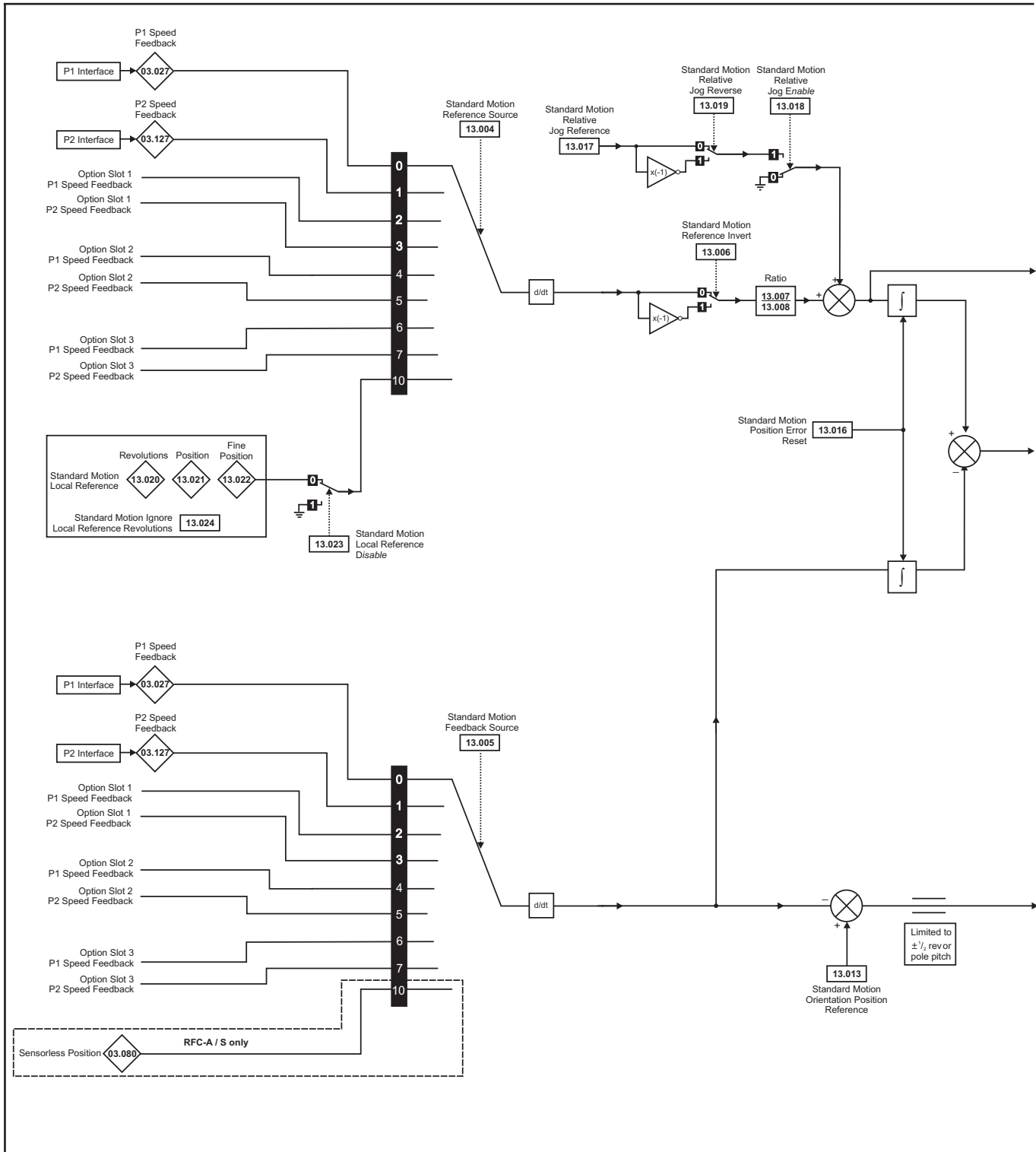

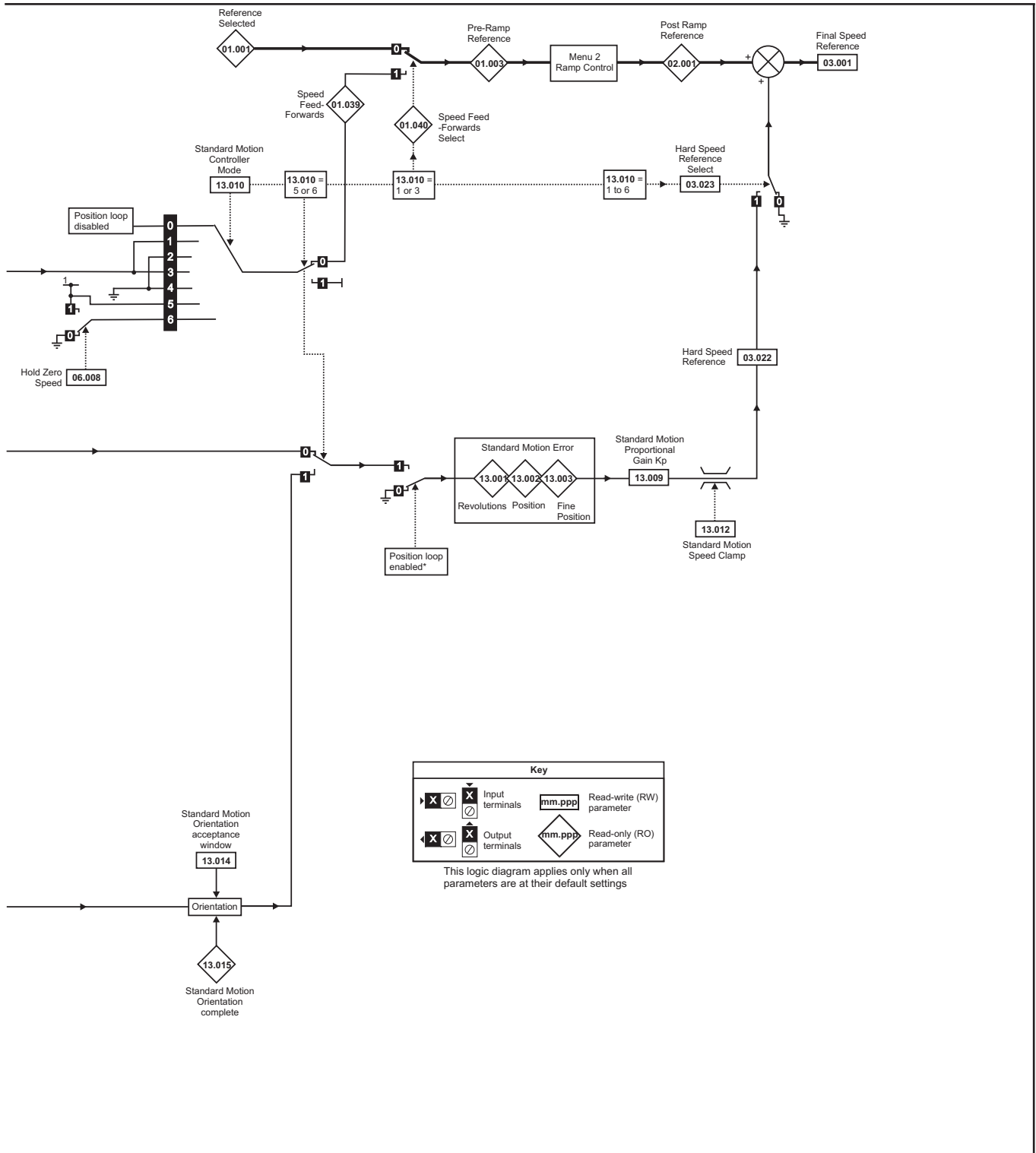

*The position controller is disabled and the error integrator is also reset under the following conditions:

1. If the drive is disabled (i.e. inhibited, ready or tripped)
2. If the position controller mode (Pr 13.010) is changed. The position controller is disabled transiently to reset the error integrator.
3. The absolute mode parameter (Pr 13.011) is changed. The position controller is disabled transiently to reset the error integrator.
4. One of the position sources is invalid.
5. The position feedback initialized parameter (Pr 03.048) is zero.

Parameter	Range(⇅)		Default(⇄)			Type						
	OL	RFC-A / S	OL	RFC-A	RFC-S							
13.001	Standard Motion Revolutions Error	-32768 to 32767 revs				RO	Num	ND	NC	PT		
13.002	Standard Motion Position Error	-32768 to 32767				RO	Num	ND	NC	PT		
13.003	Standard Motion Fine Position Error	-32768 to 32767				RO	Num	ND	NC	PT		
13.004	Standard Motion Reference Source	P1 Drive (0), P2 Drive (1), P1 Slot 1 (2), P2 Slot 1 (3), P1 Slot 2 (4), P2 Slot 2 (5), P1 Slot 3 (6), P2 Slot 3 (7), Local (10)		P1 Drive (0)			RW	Txt				US
13.005	Standard Motion Feedback Source	P1 Drive (0), P2 Drive (1), P1 Slot 1 (2), P2 Slot 1 (3), P1 Slot 2 (4), P2 Slot 2 (5), P1 Slot 3 (6), P2 Slot 3 (7)	P1 Drive (0), P2 Drive (1), P1 Slot 1 (2), P2 Slot 1 (3), P1 Slot 2 (4), P2 Slot 2 (5), P1 Slot 3 (6), P2 Slot 3 (7), Sensorless (10)	P1 Drive (0)			RW	Txt				US
13.006	Standard Motion Reference Invert	Off (0) or On (1)		Off (0)			RW	Bit				US
13.007	Standard Motion Ratio Numerator	0.000 to 10.000		1.000			RW	Num				US
13.008	Standard Motion Ratio Denominator	0.000 to 4.000		1.000			RW	Num				US
13.009	Standard Motion Proportional Gain Kp	0.00 to 100.00		25.00			RW	Num				US
13.010	Standard Motion Controller Mode	Disabled (0), Rigid Spd FF (1), Rigid (2), Non-rigid Spd FF(3), Non-Rigid (4)	Disabled (0), Rigid Spd FF (1), Rigid (2), Non-rigid Spd FF (3), Non-Rigid (4), Orientate Stop (5), Orientate (6)	Disabled (0)			RW	Txt				US
13.011	Standard Motion Absolute Mode Enable	Off (0) or On (1)		Off (0)			RW	Bit				US
13.012	Standard Motion Speed Clamp	0 to 250 rpm		150 rpm			RW	Num				US
13.013	Standard Motion Orientation Position Reference	0 to 65535		0			RW	Num				US
13.014	Standard Motion Orientation Acceptance Window	0 to 4096		256			RW	Num				US
13.015	Standard Motion Orientation Complete	Off (0) or On (1)				RO	Bit	ND	NC	PT		
13.016	Standard Motion Position Error Reset	Off (0) or On (1)		Off (0)			RW	Bit		NC		
13.017	Standard Motion Relative Jog Reference	0.0 to 4000.0 rpm		0.0 rpm			RW	Num				US
13.018	Standard Motion Relative Jog Enable	Off (0) or On (1)		Off (0)			RW	Bit		NC		
13.019	Standard Motion Relative Jog Reverse	Off (0) or On (1)		Off (0)			RW	Bit		NC		
13.020	Standard Motion Local Reference Revolutions	0 to 65535 revs		0 revs			RW	Num		NC		
13.021	Standard Motion Local Reference Position	0 to 65535		0			RW	Num		NC		
13.022	Standard Motion Local Reference Fine Position	0 to 65535		0			RW	Num		NC		
13.023	Standard Motion Local Reference Disable	Off (0) or On (1)		Off (0)			RW	Bit		NC		
13.024	Standard Motion Ignore Local Reference Revolutions	Off (0) or On (1)		Off (0)			RW	Bit				US
13.026	Standard Motion Sample Rate	Not Active (0), 4ms (1)				RO	Txt					US

RW	Read / Write	RO	Read only	Num	Number parameter	Bit	Bit parameter	Txt	Text string	Bin	Binary parameter	FI	Filtered
ND	No default value	NC	Not copied	PT	Protected parameter	RA	Rating dependent	US	User save	PS	Power-down save	DE	Destination

12.15 Menu 14: User PID controller

Figure 12-38 Menu 14 Logic diagram

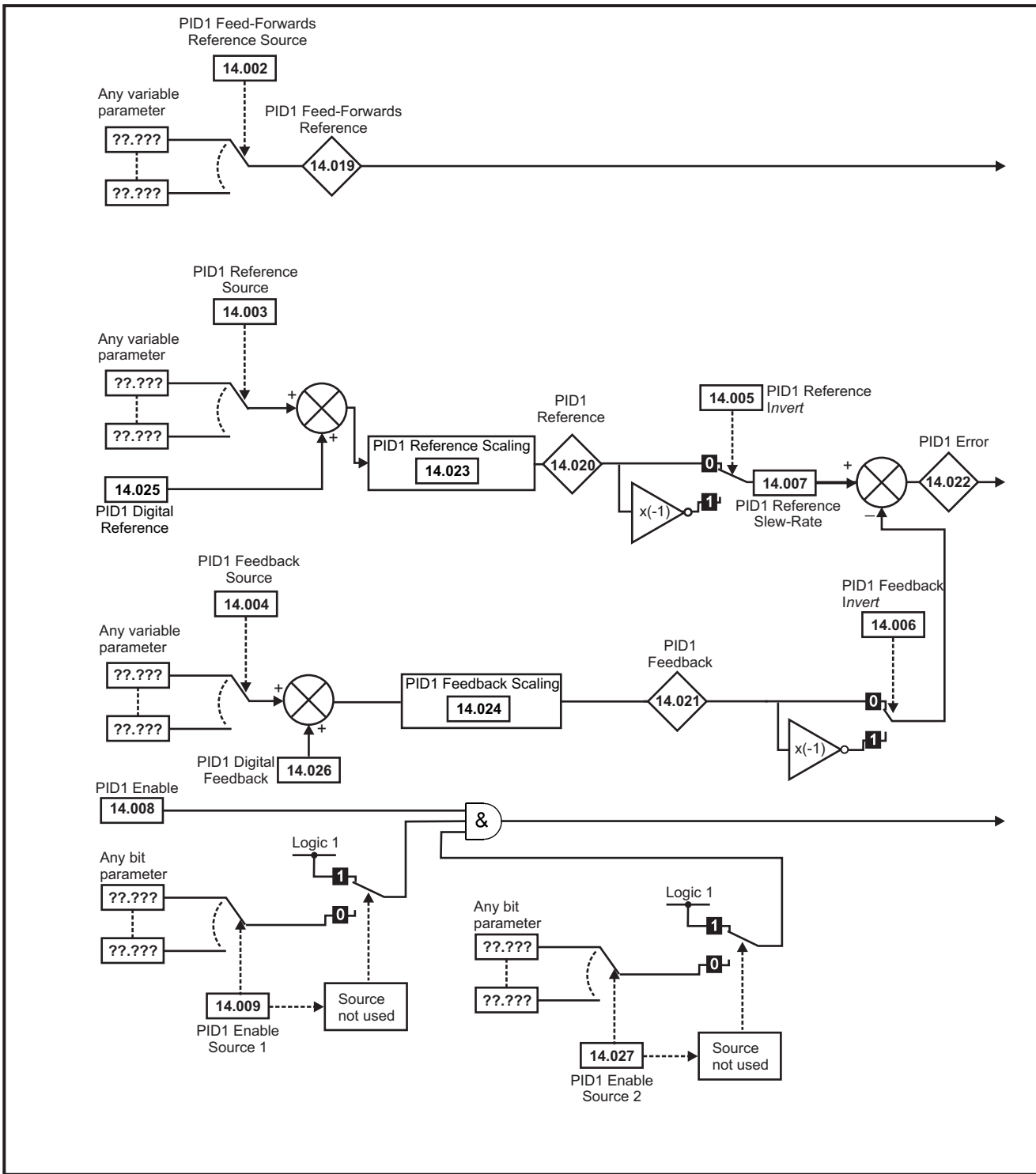

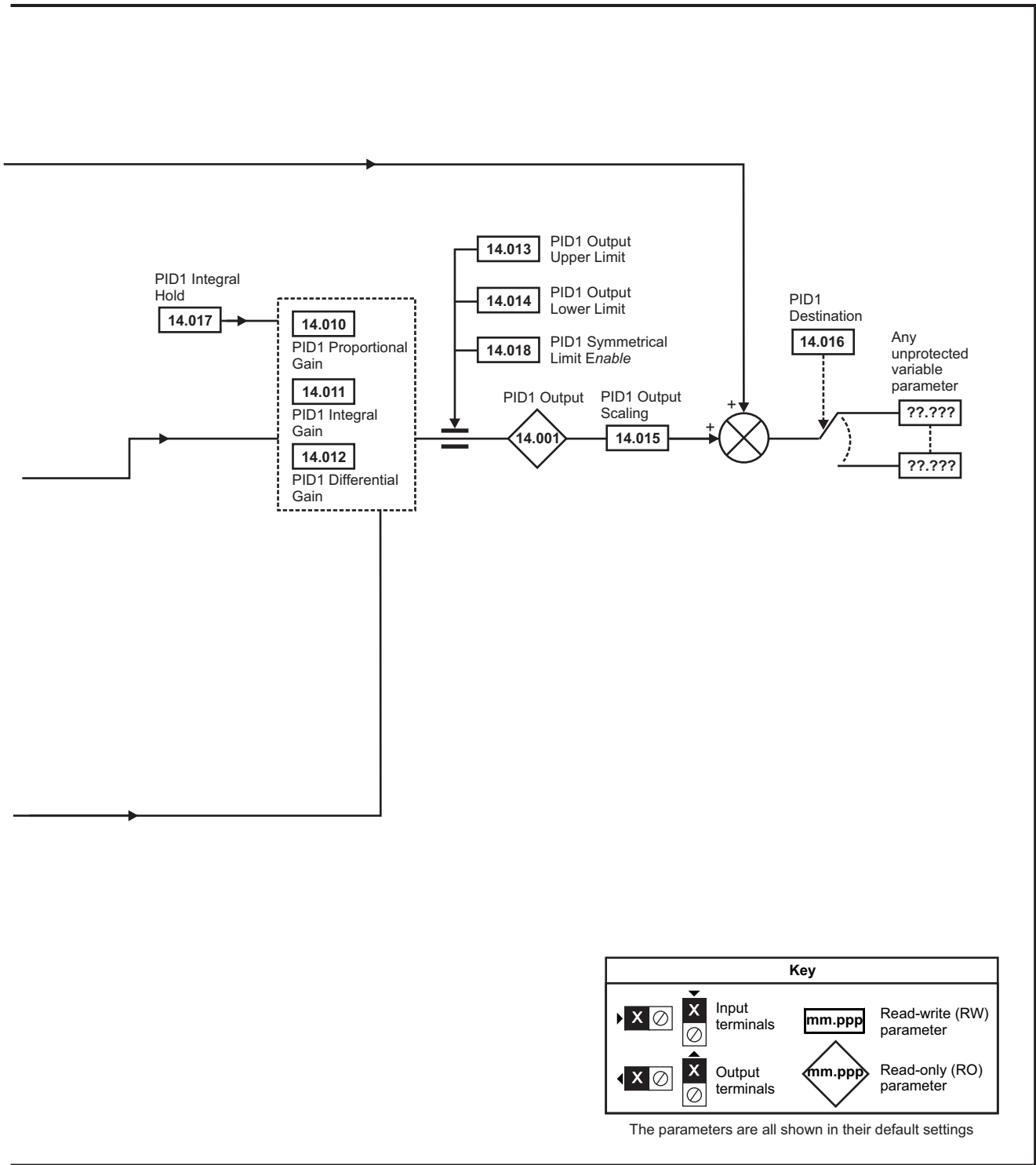

NOTE

The same logic diagram above (Menu 14) can also be used for PID2 as they are the same.

Parameter	Range(⊕)		Default(⇔)			Type					
	OL	RFC-A / S	OL	RFC-A	RFC-S						
14.001	PID1 Output	±100.00 %				RO	Num	ND	NC	PT	
14.002	PID1 Feed-forwards Reference Source	0.000 to 59.999		0.000		RW	Num			PT	US
14.003	PID1 Reference Source	0.000 to 59.999		0.000		RW	Num			PT	US
14.004	PID1 Feedback Source	0.000 to 59.999		0.000		RW	Num			PT	US
14.005	PID1 Reference Invert	Off (0) or On (1)		Off (0)		RW	Bit				US
14.006	PID1 Feedback Invert	Off (0) or On (1)		Off (0)		RW	Bit				US
14.007	PID1 Reference Slew Rate	0.0 to 3200.0 s		0.0 s		RW	Num				US
14.008	PID1 Enable	Off (0) or On (1)		Off (0)		RW	Bit				US
14.009	PID1 Enable Source 1	0.000 to 59.999		0.000		RW	Num			PT	US
14.010	PID1 Proportional Gain	0.000 to 4.000		1.000		RW	Num				US
14.011	PID1 Integral Gain	0.000 to 4.000		0.500		RW	Num				US
14.012	PID1 Differential Gain	0.000 to 4.000		0.000		RW	Num				US
14.013	PID1 Output Upper Limit	0.00 to 100.00 %		100.00 %		RW	Num				US
14.014	PID1 Output Lower Limit	±100.00 %		-100.00 %		RW	Num				US
14.015	PID1 Output Scaling	0.000 to 4.000		1.000		RW	Num				US
14.016	PID1 Destination	0.000 to 59.999		0.000		RW	Num	DE		PT	US
14.017	PID1 Integral Hold	Off (0) or On (1)		Off (0)		RW	Bit				
14.018	PID1 Symmetrical Limit Enable	Off (0) or On (1)		Off (0)		RW	Bit				US
14.019	PID1 Feed-forwards Reference	±100.00 %				RO	Num	ND	NC	PT	
14.020	PID1 Reference	±100.00 %				RO	Num	ND	NC	PT	
14.021	PID1 Feedback	±100.00 %				RO	Num	ND	NC	PT	
14.022	PID1 Error	±100.00 %				RO	Num	ND	NC	PT	
14.023	PID1 Reference Scaling	0.000 to 4.000		1.000		RW	Num				US
14.024	PID1 Feedback Scaling	0.000 to 4.000		1.000		RW	Num				US
14.025	PID1 Digital Reference	±100.00 %		0.00 %		RW	Num				US
14.026	PID1 Digital Feedback	±100.00 %		0.00 %		RW	Num				US
14.027	PID1 Enable Source 2	0.000 to 59.999		0.000		RW	Num			PT	US
14.028	PID1 Pre-sleep Boost Level	0.00 to 100.00 %		0.00 %		RW	Num				US
14.029	PID1 Maximum Boost Time	0.0 to 250.0 s		0.0 s		RW	Num				US
14.030	PID1 Pre-sleep Boost Level Enable	Off (0) or On (1)				RO	Bit	ND	NC	PT	
14.031	PID2 Output	±100.00 %				RO	Num	ND	NC	PT	
14.032	PID2 Feed-forwards Reference Source	0.000 to 59.999		0.000		RW	Num			PT	US
14.033	PID2 Reference Source	0.000 to 59.999		0.000		RW	Num			PT	US
14.034	PID2 Feedback Source	0.000 to 59.999		0.000		RW	Num			PT	US
14.035	PID2 Reference Invert	Off (0) or On (1)		Off (0)		RW	Bit				US
14.036	PID2 Feedback Invert	Off (0) or On (1)		Off (0)		RW	Bit				US
14.037	PID2 Reference Slew Rate Limit	0.0 to 3200.0 s		0.0 s		RW	Num				US
14.038	PID2 Enable	Off (0) or On (1)		Off (0)		RW	Bit				US
14.039	PID2 Enable Source 1	0.000 to 59.999		0.000		RW	Num			PT	US
14.040	PID2 Proportional Gain	0.000 to 4.000		1.000		RW	Num				US
14.041	PID2 Integral Gain	0.000 to 4.000		0.500		RW	Num				US
14.042	PID2 Differential Gain	0.000 to 4.000		0.000		RW	Num				US
14.043	PID2 Output Upper Limit	0.00 to 100.00 %		100.00 %		RW	Num				US
14.044	PID2 Output Lower Limit	±100.00 %		-100.00 %		RW	Num				US
14.045	PID2 Output Scaling	0.000 to 4.000		1.000		RW	Num				US
14.046	PID2 Destination	0.000 to 59.999		0.000		RW	Num	DE		PT	US
14.047	PID2 Integral Hold	Off (0) or On (1)		Off (0)		RW	Bit				
14.048	PID2 Symmetrical Limit Enable	Off (0) or On (1)		Off (0)		RW	Bit				US
14.049	PID2 Feed-forwards Reference	±100.00 %				RO	Num	ND	NC	PT	
14.050	PID2 Reference	±100.00 %				RO	Num	ND	NC	PT	
14.051	PID2 Feedback	±100.00 %				RO	Num	ND	NC	PT	

Parameter	Range(↕)		Default(⇔)			Type					
	OL	RFC-A / S	OL	RFC-A	RFC-S	RO	Num	ND	NC	PT	US
14.052	PID2 Error	±100.00 %				RO	Num	ND	NC	PT	US
14.053	PID2 Reference Scaling	0.000 to 4.000		1.000		RW	Num				US
14.054	PID2 Feedback Scaling	0.000 to 4.000		1.000		RW	Num				US
14.055	PID2 Digital Reference	±100.00 %		0.00 %		RW	Num				US
14.056	PID2 Digital Feedback	±100.00 %		0.00 %		RW	Num				US
14.057	PID2 Enable Source 2	0.000 to 59.999		0.000		RW	Num			PT	US
14.058	PID1 Feedback Output Scaling	0.000 to 4.000		1.000		RW	Num				US
14.059	PID1 Mode Selector	Fbk1 (0), Fbk2 (1), Fbk1 + Fbk2 (2), Min Fbk (3), Max Fbk (4), Av Fbk (5), Min Error (6), Max Error (7)		Fbk1 (0)		RW	Txt				US
14.060	PID1 Feedback Square Root Enable 1	Off (0) or On (1)		Off (0)		RW	Bit				US
14.061	PID2 Feedback Square Root Enable	Off (0) or On (1)		Off (0)		RW	Bit				US
14.062	PID1 Feedback Square Root Enable 2	Off (0) or On (1)		Off (0)		RW	Bit				US

RW	Read / Write	RO	Read only	Num	Number parameter	Bit	Bit parameter	Txt	Text string	Bin	Binary parameter	FI	Filtered
ND	No default value	NC	Not copied	PT	Protected parameter	RA	Rating dependent	US	User save	PS	Power-down save	DE	Destination

12.16 Menus 15, 16 and 17: Option module set-up

Figure 12-39 Location of option module slots and their corresponding menu numbers

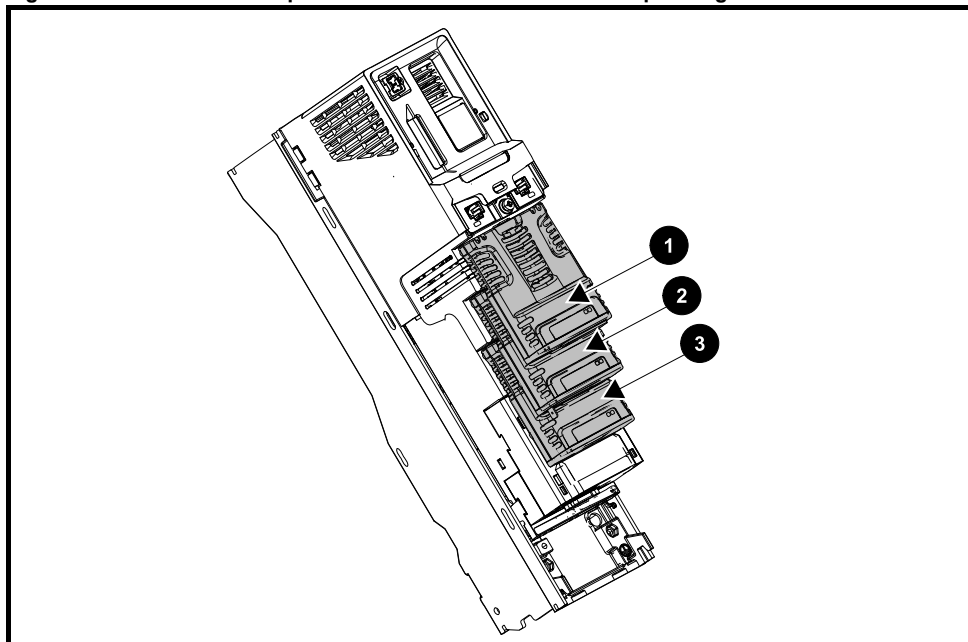

1. Solutions Module Slot 1 - Menu 15
2. Solutions Module Slot 2 - Menu 16
3. Solutions Module Slot 3 - Menu 17

12.16.1 Parameters common to all categories

Parameter	Range(⇅)	Default(⇒)	Type					
mm.001	Module ID	0 to 65535	RO	Num	ND	NC	PT	
mm.002	Software Version	00.00.00.00 to 99.99.99.99	RO	Ver	ND	NC	PT	
mm.003	Hardware Version	0.00 to 99.99	RO	Num	ND	NC	PT	
mm.004	Serial Number LS	0 to 99999999	RO	Num	ND	NC	PT	
mm.005	Serial Number MS		RO	Num	ND	NC	PT	
mm.006	Module Status	Initialising (0) to Error (3)	RO	Txt	ND	NC	PT	
mm.007	Module Reset	Off (0) or On (1)						Off (0)
			RW	Bit		NC		

The option module ID indicates the type of module that is installed in the corresponding slot. See the relevant option module user guide for more information regarding the module.

Option module ID	Module	Category
0	No module installed	
0*	SI-Safety	Safety
105	SI-Encoder	Feedback
106	SI-Universal Encoder	
209	SI-I/O	Automation (I/O Expansion)
304	SI-Applications Plus	Automation (Applications)
310	MCI210	
311	MCI200	
431	SI-EtherCAT	Fieldbus
432	SI-PROFINET RT	
433	SI-Ethernet	
434	SI-PROFINET V2	
443	SI-PROFIBUS	
447	SI-DeviceNet	
448	SI-CANopen	

* There is no communication between the SI-Safety option module and the host drive via the option module connector, this is why the SI-Safety module ID is displayed as zero.

12.17 Menu 18: Application menu 1

Parameter		Range(⌘)		Default(⇔)			Type						
		OL	RFC-A / S	OL	RFC-A	RFC-S							
18.001	Application Menu 1 Power-down Save Integer	-32768 to 32767		0			RW	Num					PS
18.002 to 18.010	Application Menu 1 Read-only Integer	-32768 to 32767					RO	Num	ND	NC			US
18.011 to 18.030	Application Menu 1 Read-write Integer	-32768 to 32767		0			RW	Num					US
18.031 to 18.050	Application Menu 1 Read-write bit	Off (0) or On (1)		Off (0)			RW	Bit					US
18.051 to 18.054	Application Menu 1 Power-down Save long Integer	-2147483648 to 2147483647		0			RW	Num					PS

12.18 Menu 19: Application menu 2

Parameter		Range(⌘)		Default(⇔)			Type						
		OL	RFC-A / S	OL	RFC-A	RFC-S							
19.001	Application Menu 2 Power-down Save Integer	-32768 to 32767		0			RW	Num					PS
19.002 to 19.010	Application Menu 2 Read-only Integer	-32768 to 32767					RO	Num	ND	NC			US
19.011 to 19.030	Application Menu 2 Read-write Integer	-32768 to 32767		0			RW	Num					US
19.031 to 19.050	Application Menu 2 Read-write bit	Off (0) or On (1)		Off (0)			RW	Bit					US
19.051 to 19.054	Application Menu 2 Power-down Save long Integer	-2147483648 to 2147483647		0			RW	Num					PS

12.19 Menu 20: Application menu 3

Parameter		Range(⌘)		Default(⇔)			Type						
		OL	RFC-A / S	OL	RFC-A	RFC-S							
20.001 to 20.020	Application Menu 3 Read-write Integer	-32768 to 32767		0			RW	Num					
20.021 to 20.040	Application Menu 3 Read-write Long Integer	-2147483648 to 2147483647		0			RW	Num					

RW	Read / Write	RO	Read only	Num	Number parameter	Bit	Bit parameter	Txt	Text string	Bin	Binary parameter	FI	Filtered
ND	No default value	NC	Not copied	PT	Protected parameter	RA	Rating dependent	US	User save	PS	Power-down save	DE	Destination

12.20 Menu 21: Second motor parameters

Parameter	Range(⊕)			Default(⇒)			Type					
	OL	RFC-A	RFC-S	OL	RFC-A	RFC-S						
21.001	M2 Maximum Reference Clamp	VM_POSITIVE_REF_CLAMP2 Hz	VM_POSITIVE_REF_CLAMP2 rpm	50 Hz: 50.0 60 Hz: 60.0	50 Hz: 1500.0 60 Hz: 1800.0	3000.0	RW	Num				US
21.002	M2 Minimum Reference Clamp	VM_NEGATIVE_REF_CLAMP2 Hz	VM_NEGATIVE_REF_CLAMP2 rpm	0.0			RW	Num				US
21.003	M2 Reference Selector	A1 A2 (0), A1 Preset (1), A2 Preset (2), Preset (3), Keypad (4), Precision (5), Keypad Ref (6)		A1 A2 (0)			RW	Txt				US
21.004	M2 Acceleration Rate 1	0.0 to VM_ACCEL_RATE s/100 Hz	0.000 to VM_ACCEL_RATE s/100 rpm	5.0 s	2.000 s	0.200 s	RW	Num				US
21.005	M2 Deceleration Rate 1	0.0 to VM_ACCEL_RATE s/100 Hz	0.000 to VM_ACCEL_RATE s/100 rpm	10.0 s	2.000 s	0.200 s	RW	Num				US
21.006	M2 Rated Frequency	0.0 to 599.0 Hz	0.0 to 550.0 Hz	50Hz: 50.0 Hz 60Hz: 60.0 Hz			RW	Num				US
21.007	M2 Rated Current	0.000 to VM_RATED_CURRENT A		Maximum Heavy Duty Rating (11.032)			RW	Num		RA		US
21.008	M2 Rated Speed	0 to 35940 rpm	0.00 to 33000.00 rpm	50 Hz: 1500 rpm 60 Hz: 1800 rpm	50 Hz: 1450.00 rpm 60 Hz: 1750.00 rpm	3000.00 rpm	RW	Num				US
21.009	M2 Rated Voltage	0 to VM_AC_VOLTAGE_SET V		200V drive: 230 V 400V drive 50Hz: 400 V 400V drive 60Hz: 460 V 575V drive: 575 V 690V drive: 690 V			RW	Num		RA		US
21.010	M2 Rated Power Factor	0.000 to 1.000		0.850			RW	Num		RA		US
21.011	M2 Number Of Motor Poles	Automatic (0) to 480 Poles (240)		Automatic (0)			6 Poles (3)	RW	Txt			US
21.012	M2 Stator Resistance	0.000000 to 1000.000000 Ω			0.000000 Ω			RW	Num		RA	US
21.014	M2 Transient Inductance / Ld	0.000 to 500.000 mH			0.000 mH			RW	Num		RA	US
21.015	Motor 2 Active	Off (0) or On (1)						RO	Bit	ND	NC	PT
21.016	M2 Motor Thermal Time Constant 1	1.0 to 3000.0 s			89.0 s			RW	Num			US
21.017	M2 Speed Controller Proportional Gain Kp1			0.0000 to 200.0000 s/rad	0.0300 s/rad	0.0100 s/rad	RW	Num				US
21.018	M2 Speed Controller Integral Gain Ki1			0.00 to 655.35 s ² /rad	0.10 s ² /rad	1.00 s ² /rad	RW	Num				US
21.019	M2 Speed Controller Differential Feedback Gain Kd1			0.00000 to 0.65535 1/rad	0.00000 1/rad			RW	Num			US
21.020	M2 Position Feedback Phase Angle			0.0 to 359.9 °	0.0 °			RW	Num	ND		US
21.021	M2 Motor Control Feedback Select			P1 Drive (0), P2 Drive (1), P1 Slot 1 (2), P2 Slot 1 (3), P1 Slot 2 (4), P2 Slot 2 (5), P1 Slot 3 (6), P2 Slot 3 (7)	P1 Drive (0)			RW	Txt			US
21.022	M2 Current Controller Kp Gain	0 to 30000			20	150	RW	Num				US
21.023	M2 Current Controller Ki Gain	0 to 30000			40	2000	RW	Num				US
21.024	M2 Stator Inductance	0.00 to 5000.00 mH		0.00 mH			RW	Num		RA		US
21.025	M2 Saturation Breakpoint 1			0.0 to 100.0 %	50.0 %			RW	Num			US
21.026	M2 Saturation Breakpoint 3			0.0 to 100.0 %	75.0 %			RW	Num			US
21.027	M2 Motoring Current Limit	0.0 to VM_MOTOR2_CURRENT_LIMIT %			165.0 %*	175.0 %**		RW	Num		RA	US
21.028	M2 Regenerating Current Limit	0.0 to VM_MOTOR2_CURRENT_LIMIT %			165.0 %*	175.0 %**		RW	Num		RA	US
21.029	M2 Symmetrical Current Limit	0.0 to VM_MOTOR2_CURRENT_LIMIT %			165.0 %*	175.0 %**		RW	Num		RA	US
21.030	M2 Volts Per 1000 rpm			0 to 10,000 V	98 V			RW	Num			US
21.032	M2 Current Reference Filter Time Constant 1				0.0 to 25.0 ms	0.0 ms		RW	Num			US
21.033	M2 Low Speed Thermal Protection Mode				0 to 1	0		RW	Num			US
21.034	M2 Current Controller Mode				Off (0) or On (1)	Off (0)		RW	Bit			US
21.035	M2 Notch Filter Centre Frequency				50 to 1000 Hz	100 Hz		RW	Num			US
21.036	M2 Notch Filter Bandwidth				0 to 500 Hz	0 Hz		RW	Num			US
21.039	M2 Motor Thermal Time Constant 2				1.0 to 3000.0 s	89.0 s		RW	Num			US
21.040	M2 Motor Thermal Time Constant 2 Scaling				0 to 100 %	0 %		RW	Num			US
21.041	M2 Saturation Breakpoint 2			0.0 to 100.0 %	0.0 %			RW	Num			US
21.042	M2 Saturation Breakpoint 4			0.0 to 100.0 %	0.0 %			RW	Num			US
21.043	M2 Torque Per Amp			0.00 to 500.00 Nm/A				RO	Num	ND	NC	PT
	M2 Torque Per Amp				0.00 to 500.00 Nm/A	1.60 Nm/A		RW	Num			US

Parameter		Range(⇅)			Default(⇒)			Type					
		OL	RFC-A	RFC-S	OL	RFC-A	RFC-S						
21.044	M2 No-load Core Loss	0.000 to 99999.999 kW			0.000 kW			RW	Num				US
21.045	M2 Rated Core Loss	0.000 to 99999.999 kW			0.000 kW			RW	Num				US
21.046	RFC A: M2 Magnetising Current Limit		0.0 to 100.0 %			100.0 %		RW	Num				US
	RFC S: M2 Inverted Motor Saturation Characteristic			Off (0) or On (1)			Off (0)	RW	Bit				US
21.048	M2 No-load Lq			0.000 to 500.000 mH			0.000 mH	RW	Num		RA		US

* For size 9 and above the default is 141.9 %

** For size 9 and above the default is 150.0 %

RW	Read / Write	RO	Read only	Num	Number parameter	Bit	Bit parameter	Txt	Text string	Bin	Binary parameter	FI	Filtered
ND	No default value	NC	Not copied	PT	Protected parameter	RA	Rating dependent	US	User save	PS	Power-down save	DE	Destination

12.21 Menu 22: Additional Menu 0 set-up

Parameter	Range(⇅)			Default(⇄)			Type						
	OL	RFC-A	RFC-S	OL	RFC-A	RFC-S							
22.001	Parameter 00.001 Set-up	0.000 to 59.999			1.007			RW	Num			PT	US
22.002	Parameter 00.002 Set-up	0.000 to 59.999			1.006			RW	Num			PT	US
22.003	Parameter 00.003 Set-up	0.000 to 59.999			2.011			RW	Num			PT	US
22.004	Parameter 00.004 Set-up	0.000 to 59.999			2.021			RW	Num			PT	US
22.005	Parameter 00.005 Set-up	0.000 to 59.999			1.014			RW	Num			PT	US
22.006	Parameter 00.006 Set-up	0.000 to 59.999			4.007			RW	Num			PT	US
22.007	Parameter 00.007 Set-up	0.000 to 59.999			5.014	3.010		RW	Num			PT	US
22.008	Parameter 00.008 Set-up	0.000 to 59.999			5.015	3.011		RW	Num			PT	US
22.009	Parameter 00.009 Set-up	0.000 to 59.999			5.013	3.012		RW	Num			PT	US
22.010	Parameter 00.010 Set-up	0.000 to 59.999			5.004	3.002		RW	Num			PT	US
22.011	Parameter 00.011 Set-up	0.000 to 59.999			5.001		3.029	RW	Num			PT	US
22.012	Parameter 00.012 Set-up	0.000 to 59.999			4.001			RW	Num			PT	US
22.013	Parameter 00.013 Set-up	0.000 to 59.999			4.002			RW	Num			PT	US
22.014	Parameter 00.014 Set-up	0.000 to 59.999			4.011			RW	Num			PT	US
22.015	Parameter 00.015 Set-up	0.000 to 59.999			2.004			RW	Num			PT	US
22.016	Parameter 00.016 Set-up	0.000 to 59.999			0.000	2.002		RW	Num			PT	US
22.017	Parameter 00.017 Set-up	0.000 to 59.999			8.026	4.012		RW	Num			PT	US
22.018	Parameter 00.018 Set-up	0.000 to 59.999			3.123			RW	Num			PT	US
22.019	Parameter 00.019 Set-up	0.000 to 59.999			7.011*			RW	Num			PT	US
22.020	Parameter 00.020 Set-up	0.000 to 59.999			7.014*			RW	Num			PT	US
22.021	Parameter 00.021 Set-up	0.000 to 59.999			7.015*			RW	Num			PT	US
22.022	Parameter 00.022 Set-up	0.000 to 59.999			1.010			RW	Num			PT	US
22.023	Parameter 00.023 Set-up	0.000 to 59.999			1.005			RW	Num			PT	US
22.024	Parameter 00.024 Set-up	0.000 to 59.999			1.021			RW	Num			PT	US
22.025	Parameter 00.025 Set-up	0.000 to 59.999			1.022			RW	Num			PT	US
22.026	Parameter 00.026 Set-up	0.000 to 59.999			1.023	3.008		RW	Num			PT	US
22.027	Parameter 00.027 Set-up	0.000 to 59.999			1.024	3.034		RW	Num			PT	US
22.028	Parameter 00.028 Set-up	0.000 to 59.999			6.013			RW	Num			PT	US
22.029	Parameter 00.029 Set-up	0.000 to 59.999			11.036			RW	Num			PT	US
22.030	Parameter 00.030 Set-up	0.000 to 59.999			11.042			RW	Num			PT	US
22.031	Parameter 00.031 Set-up	0.000 to 59.999			11.033			RW	Num			PT	US
22.032	Parameter 00.032 Set-up	0.000 to 59.999			11.032			RW	Num			PT	US
22.033	Parameter 00.033 Set-up	0.000 to 59.999			6.009	5.016	0.000	RW	Num			PT	US
22.034	Parameter 00.034 Set-up	0.000 to 59.999			11.030			RW	Num			PT	US
22.035	Parameter 00.035 Set-up	0.000 to 59.999			11.024**			RW	Num			PT	US
22.036	Parameter 00.036 Set-up	0.000 to 59.999			11.025**			RW	Num			PT	US
22.037	Parameter 00.037 Set-up	0.000 to 59.999			11.023** / 24.010***			RW	Num			PT	US
22.038	Parameter 00.038 Set-up	0.000 to 59.999			4.013			RW	Num			PT	US
22.039	Parameter 00.039 Set-up	0.000 to 59.999			4.014			RW	Num			PT	US
22.040	Parameter 00.040 Set-up	0.000 to 59.999			5.012			RW	Num			PT	US
22.041	Parameter 00.041 Set-up	0.000 to 59.999			5.018			RW	Num			PT	US
22.042	Parameter 00.042 Set-up	0.000 to 59.999			5.011			RW	Num			PT	US
22.043	Parameter 00.043 Set-up	0.000 to 59.999			5.010	3.025		RW	Num			PT	US
22.044	Parameter 00.044 Set-up	0.000 to 59.999			5.009			RW	Num			PT	US
22.045	Parameter 00.045 Set-up	0.000 to 59.999			5.008	0.000		RW	Num			PT	US
22.046	Parameter 00.046 Set-up	0.000 to 59.999			5.007			RW	Num			PT	US
22.047	Parameter 00.047 Set-up	0.000 to 59.999			5.006	5.033		RW	Num			PT	US
22.048	Parameter 00.048 Set-up	0.000 to 59.999			11.031			RW	Num			PT	US
22.049	Parameter 00.049 Set-up	0.000 to 59.999			11.044			RW	Num			PT	US
22.050	Parameter 00.050 Set-up	0.000 to 59.999			11.029			RW	Num			PT	US
22.051	Parameter 00.051 Set-up	0.000 to 59.999			10.037			RW	Num			PT	US
22.052	Parameter 00.052 Set-up	0.000 to 59.999			11.020**			RW	Num			PT	US
22.053	Parameter 00.053 Set-up	0.000 to 59.999			4.015			RW	Num			PT	US
22.054	Parameter 00.054 Set-up	0.000 to 59.999			0.000			RW	Num			PT	US
22.055	Parameter 00.055 Set-up	0.000 to 59.999			0.000			RW	Num			PT	US
22.056	Parameter 00.056 Set-up	0.000 to 59.999			0.000			RW	Num			PT	US
22.057	Parameter 00.057 Set-up	0.000 to 59.999			0.000			RW	Num			PT	US

Parameter	Range(↕)	Default(⇒)			Type							
		OL	RFC-A	RFC-S								
22.058	Parameter 00.058 Set-up	0.000 to 59.999			0.000		RW	Num			PT	US
22.059	Parameter 00.059 Set-up	0.000 to 59.999			0.000		RW	Num			PT	US
22.060	Parameter 00.060 Set-up	0.000 to 59.999			0.000		RW	Num			PT	US
22.061	Parameter 00.061 Set-up	0.000 to 59.999			0.000		RW	Num			PT	US
22.062	Parameter 00.062 Set-up	0.000 to 59.999			0.000		RW	Num			PT	US
22.063	Parameter 00.063 Set-up	0.000 to 59.999			0.000		RW	Num			PT	US
22.064	Parameter 00.064 Set-up	0.000 to 59.999			0.000		RW	Num			PT	US
22.065	Parameter 00.065 Set-up	0.000 to 59.999			0.000		RW	Num			PT	US
22.066	Parameter 00.066 Set-up	0.000 to 59.999			0.000		RW	Num			PT	US
22.067	Parameter 00.067 Set-up	0.000 to 59.999			0.000		RW	Num			PT	US
22.068	Parameter 00.068 Set-up	0.000 to 59.999			0.000		RW	Num			PT	US
22.069	Parameter 00.069 Set-up	0.000 to 59.999			0.000		RW	Num			PT	US
22.070	Parameter 00.070 Set-up	0.000 to 59.999			0.000		RW	Num			PT	US
22.071	Parameter 00.071 Set-up	0.000 to 59.999			0.000		RW	Num			PT	US
22.072	Parameter 00.072 Set-up	0.000 to 59.999			0.000		RW	Num			PT	US
22.073	Parameter 00.073 Set-up	0.000 to 59.999			0.000		RW	Num			PT	US
22.074	Parameter 00.074 Set-up	0.000 to 59.999			0.000		RW	Num			PT	US
22.075	Parameter 00.075 Set-up	0.000 to 59.999			0.000		RW	Num			PT	US
22.076	Parameter 00.076 Set-up	0.000 to 59.999			0.000		RW	Num			PT	US
22.077	Parameter 00.077 Set-up	0.000 to 59.999			0.000		RW	Num			PT	US
22.078	Parameter 00.078 Set-up	0.000 to 59.999			0.000		RW	Num			PT	US
22.079	Parameter 00.079 Set-up	0.000 to 59.999			0.000		RW	Num			PT	US
22.080	Parameter 00.080 Set-up	0.000 to 59.999			0.000		RW	Num			PT	US

* 0.000 on Unidrive M702.

** On Unidrive M701.

*** On Unidrive M700 / M702.

RW	Read / Write	RO	Read only	Num	Number parameter	Bit	Bit parameter	Txt	Text string	Bin	Binary parameter	FI	Filtered
ND	No default value	NC	Not copied	PT	Protected parameter	RA	Rating dependent	US	User save	PS	Power-down save	DE	Destination

12.22 Menu 24: Ethernet interface information (Unidrive M700 / M702)

Parameter	Range	Default			Type	
		OL	RFC-A	RFC-S		
24.001	Module ID	0 to 65535			RO Num ND NC PT	
24.002	Software Version	00.00.00.00 to 99.99.99.99			RO Num ND NC PT	
24.003	Hardware Version	0.00 to 99.99			RO Num ND NC PT	
24.004	Serial Number LS	00000000 to 99999999			RO Num ND NC PT	
24.005	Serial Number MS	0 to 99999999			RO Num ND NC PT	
24.006	Status	Bootldr-Update (-2), Bootldr-Idle (-1), Initializing (0), OK (1), Config (2), Error (3)			RO Txt ND NC PT	
24.007	Reset	Off (0) or On (1)			RW Bit NC	
24.008	Default	Off (0) or On (1)			RW Bit NC	
24.009	Active Alarm Bits	0000000000000000 to 1111111111111111			RO Bin NC	
24.010	Active IP Address	0.0.0.0 to 255.255.255.255			RO IP NC PT	
24.011	Date Code	0 to 65535			RO Num ND NC PT	

RW	Read / Write	RO	Read only	Num	Number parameter	Bit	Bit parameter	Txt	Text string	Bin	Binary parameter	FI	Filtered
ND	No default value	NC	Not copied	PT	Protected parameter	RA	Rating dependent	US	User save	PS	Power-down save	DE	Destination
IP	IP address	Mac	Mac address	Date	Date parameter	Time	Time parameter	SMP	Slot,menu,parameter	Chr	Character parameter	Ver	Version number

12.23 Slot 4 Menus (*Unidrive M700 / M702*)

The following table shows the internal menus of the Ethernet interface.

Menu	Description
4.00	Module information
4.02	Ethernet configuration
4.09	Resources
4.10	RTMoE Easy mode cyclic data
4.11	RTMoE Synchronisation
4.15	Modbus TCP/IP Setup
4.20	EtherNet/IP Setup
4.21	EtherNet/IP Input mappings
4.22	EtherNet/IP Output mappings
4.23	EtherNet/IP Fault values
4.24	Profinet Setup

12.24 Slot 4 Menu 0: Ethernet interface information (*Unidrive M700 / M702*)

Parameter	Range			Default			Type						
	OL	RFC-A	RFC-S	OL	RFC-A	RFC-S							
4.00.001	Module ID	0 to 65535						RO	Num	ND	NC	PT	
4.00.002	Software Version	00.00.00.00 to 99.99.99.99						RO	Num	ND	NC	PT	
4.00.003	Hardware Version	0.00 to 99.99						RO	Num	ND	NC	PT	
4.00.004	Serial Number LS	00000000 to 99999999						RO	Num	ND	NC	PT	
4.00.005	Serial Number MS	0 to 99999999						RO	Num	ND	NC	PT	
4.00.006	Status	Bootldr-Update (-2), Bootldr-Idle (-1), Initializing (0), OK (1), Config (2), Error (3)						RO	Txt	ND	NC	PT	
4.00.007	Reset	Off (0) or On (1)			Off (0)			RW	Bit		NC		
4.00.008	Default	Off (0) or On (1)			Off (0)			RW	Bit		NC		
4.00.009	Active Alarm Bits	0000000000000000 to 1111111111111111						RO	Bin		NC		
4.00.010	Active IP Address	0.0.0.0 to 255.255.255.255						RO	IP		NC	PT	
4.00.011	Date Code	0 to 65535						RO	Num	ND	NC	PT	

RW	Read / Write	RO	Read only	Num	Number parameter	Bit	Bit parameter	Txt	Text string	Bin	Binary parameter	FI	Filtered
ND	No default value	NC	Not copied	PT	Protected parameter	RA	Rating dependent	US	User save	PS	Power-down save	DE	Destination
IP	IP address	Mac	Mac address	Date	Date parameter	Time	Time parameter	SMP	Slot,menu,parameter	Chr	Character parameter	Ver	Version number

12.25 Slot 4 Menu 2: Ethernet configuration (Unidrive M700 / M702)

Parameter	Range			Default			Type						
	OL	RFC-A	RFC-S	OL	RFC-A	RFC-S							
4.02.003	Network Status	Initializing (0), Links Down (1), DHCP In Progress (2), No Address (3), Ready (4), Active (5)						RO	Txt	ND	NC	PT	
4.02.004	Network Message Count	0 to 65535 Messages/s						RO	Num	ND	NC	PT	
4.02.005	DHCP Enable	Off (0) or On (1)			On (1)			RW	Bit				US
4.02.006	IP Address	0.0.0.0 to 255.255.255.255			192.168.001.100			RW	IP				US
4.02.007	Subnet Mask	0.0.0.0 to 255.255.255.255			255.255.255.000			RW	IP				US
4.02.008	Default Gateway	0.0.0.0 to 255.255.255.255			192.168.1.254			RW	IP				US
4.02.009	Primary DNS	0.0.0.0 to 255.255.255.255			0.0.0.0			RW	IP				US
4.02.010	Secondary DNS	0.0.0.0 to 255.255.255.255			0.0.0.0			RW	IP				US
4.02.011	MAC Address	00:00:00:00:00:00 to FF:FF:FF:FF:FF:FF						RO	Mac	ND	NC	PT	
4.02.018	Protocol Mode Select	Ethernet/IP (1) to Profinet (2)			Ethernet/IP (1)			RW	Txt				US
4.02.019	Active Protocol Mode	Ethernet/IP (1) to Profinet (2)						RO	Txt		NC	PT	
4.02.020	Priority Protocol	None (0), Modbus TCP (1), EtherNet/IP (2)			0			RW	Txt				US
4.02.021	Web Server Enable	Off (0) or On (1)			On (1)			RW	Bit				US
4.02.022	Web Server Port	0 to 65535			80			RW	Num				US
4.02.024	Ethernet MTU*	158 to 1500 Bytes			1500 Bytes			RW	Num				US
4.02.025	Gateway Mode	Switch (0), Gateway (1), Strict Gateway (2)			Switch (0)			RW	Txt				US
4.02.030	VLAN Enable	Off (0) or On (1)			Off (0)			RW	Bit				US
4.02.034	Drive compatibility mode	Unidrive M (0) or Unidrive SP (1)			Unidrive M (0)			RW	Txt				US
4.02.035	Non cyclic enable	Off (0) or On (1)			Off (0)			RW	Bit				US
4.02.036	Non cyclic base parameter	0.00.000 to 0.59.999			0.00.000			RW	SMP				US

RW	Read / Write	RO	Read only	Num	Number parameter	Bit	Bit parameter	Txt	Text string	Bin	Binary parameter	FI	Filtered
ND	No default value	NC	Not copied	PT	Protected parameter	RA	Rating dependent	US	User save	PS	Power-down save	DE	Destination
IP	IP address	Mac	Mac address	Date	Date parameter	Time	Time parameter	SMP	Slot,menu,parameter	Chr	Character parameter	Ver	Version number

* This parameter is now not used, the maximum Ethernet packet size is limited to 400 bytes.

12.26 Slot 4 Menu 9: Resources (Unidrive M700 / M702)

Parameter	Range			Default			Type						
	OL	RFC-A	RFC-S	OL	RFC-A	RFC-S							
4.09.001	Cyclic Tx Links Free	0 to 255						RO	Num	ND	NC	PT	
4.09.002	Cyclic Rx Links Free	0 to 255						RO	Num	ND	NC	PT	
4.09.003	Fieldbus Links Free	0 to 255						RO	Num	ND	NC	PT	
4.09.004	Cyclic Mappings Free	0 to 255						RO	Num	ND	NC	PT	
4.09.008	Background cycles per second	0 to 65535						RO	Num	ND	NC	PT	
4.09.010	Synchronous Task % Free	0 to 255 %						RO	Num	ND	NC	PT	
4.09.011	Nonsync link update period	0.00 to 655.35						RO	Num	ND	NC	PT	
4.09.020	Synchronous Task % Worst Free	0 to 255 %						RO	Num	ND	NC	PT	
4.09.021	Max nonsync link update period	0.00 to 655.35						RO	Num	ND	NC	PT	
4.09.030	PCB Temperature	-128 to 127 °C						RO	Num	ND	NC	PT	

RW	Read / Write	RO	Read only	Num	Number parameter	Bit	Bit parameter	Txt	Text string	Bin	Binary parameter	FI	Filtered
ND	No default value	NC	Not copied	PT	Protected parameter	RA	Rating dependent	US	User save	PS	Power-down save	DE	Destination

12.27 Slot 4 Menu 10: RTMoE Easy Mode Cyclic Data (Unidrive M700 / M702)

Parameter		Range			Default			Type					
		OL	RFC-A	RFC-S	OL	RFC-A	RFC-S						
4.10.001	Enable	Off (0) or On (1)			On (1)			RW	Bit				US
4.10.002	Reset	Off (0) or On (1)			Off (0)			RW	Bit		NC		
4.10.003	Default	Off (0) or On (1)			Off (0)			RW	Bit		NC		
4.10.004	Cyclic Messages Per Second	0 to 65535 Messages/s						RO	Num	ND	NC	PT	
4.10.005	Configuration Valid	Off (0) or On (1)						RO	Bit	ND	NC	PT	
4.10.006	Operational	Off (0) or On (1)						RO	Bit	ND	NC	PT	
4.10.007	Active Configuration	None (0), Easy Mode (1), Offline (2)						RO	Txt	ND	NC	PT	
4.10.008	Timeout Count	0 to 65535						RO	Num	ND	NC	PT	
4.10.009	Data Late Count	0 to 65535						RO	Num	ND	NC	PT	
4.10.010	Tx1 Link Profile	Std (0), Sync (1)			Std (0)			RW	Txt				US
4.10.011	Tx1 Link Number	0 to 255			0			RW	Num				US
4.10.012	Tx1 Source Parameter	0.00.000 to 4.99.999			0.00.000			RW	SMP			PT	US
4.10.013	Tx1 Parameter Count	0 to 10			0			RW	Num				US
4.10.014	Tx1 Link Transmission Type	Unicast (0), Broadcast (1), Multicast1 (2), Multicast2 (3), Multicast3 (4), Multicast4 (5), Multicast5 (6), Multicast6 (7), Multicast7 (8), Multicast8 (9), Multicast9 (10), Multicast10 (11)			Unicast (0)			RW	Txt				US
4.10.015	Tx1 Destination Address	0.0.0.0 to 255.255.255.255			0.0.0.0			RW	IP				US
4.10.016	Tx1 Message Rate	0 to 100 ms			0 ms			RW	Num				US
4.10.019	Tx1 Link Status	Disabled (-31), VLAN disabled (-30), Invalid DST IP (-22), SYNC unsupported (-21), MEC offset (-20), Invalid tx rate (-19), Too many mapping (-18), Link busy (-17), Invalid profile (-16), Invalid mapping (-15), Read only param (-14), Msg mismatch (-13), Msg too long (-12), Attrib NA (-11), Attrib RO (-10), Attrib missing (-9), Timeout (-8), In error (-7), Link num in use (-6), Not editable (-5), Invalid link num (-4), Invalid args (-3), Too many links (-2), Out of memory (-1), OK (0), Not running (1), OK sync (2)						RO	Txt	ND	NC	PT	
4.10.020	Tx2 Link Profile	Std (0), Sync (1)			Std (0)			RW	Txt				US
4.10.021	Tx2 Link Number	0 to 255			0			RW	Num				US
4.10.022	Tx2 Source Parameter	0.00.000 to 4.99.999			0.00.000			RW	SMP			PT	US
4.10.023	Tx2 Parameter Count	0 to 10			0			RW	Num				US
4.10.024	Tx2 Link Transmission Type	Unicast (0), Broadcast (1), Multicast1 (2), Multicast2 (3), Multicast3 (4), Multicast4 (5), Multicast5 (6), Multicast6 (7), Multicast7 (8), Multicast8 (9), Multicast9 (10), Multicast10 (11)			Unicast (0)			RW	Txt				US
4.10.025	Tx2 Destination Address	0.0.0.0 to 255.255.255.255			0.0.0.0			RW	IP				US
4.10.026	Tx2 Message Rate	0 to 100 ms			0 ms			RW	Num				US
4.10.029	Tx2 Link Status	Disabled (-31), VLAN disabled (-30), Invalid DST IP (-22), SYNC unsupported (-21), MEC offset (-20), Invalid tx rate (-19), Too many mapping (-18), Link busy (-17), Invalid profile (-16), Invalid mapping (-15), Read only param (-14), Msg mismatch (-13), Msg too long (-12), Attrib NA (-11), Attrib RO (-10), Attrib missing (-9), Timeout (-8), In error (-7), Link num in use (-6), Not editable (-5), Invalid link num (-4), Invalid args (-3), Too many links (-2), Out of memory (-1), OK (0), Not running (1), OK sync (2)						RO	Txt	ND	NC	PT	
4.10.030	Tx3 Link Profile	Std (0), Sync (1)			Std (0)			RW	Txt				US
4.10.031	Tx3 Link Number	0 to 255			0			RW	Num				US
4.10.032	Tx3 Source Parameter	0.00.000 to 4.99.999			0.00.000			RW	SMP			PT	US
4.10.033	Tx3 Parameter Count	0 to 10			0			RW	Num				US
4.10.034	Tx3 Link Transmission Type	Unicast (0), Broadcast (1), Multicast1 (2), Multicast2 (3), Multicast3 (4), Multicast4 (5), Multicast5 (6), Multicast6 (7), Multicast7 (8), Multicast8 (9), Multicast9 (10), Multicast10 (11)			Unicast (0)			RW	Txt				US
4.10.035	Tx3 Destination Address	0.0.0.0 to 255.255.255.255			0.0.0.0			RW	IP				US
4.10.036	Tx3 Message Rate	0 to 100 ms			0 ms			RW	Num				US
4.10.039	Tx3 Link Status	Disabled (-31), VLAN disabled (-30), Invalid DST IP (-22), SYNC unsupported (-21), MEC offset (-20), Invalid tx rate (-19), Too many mapping (-18), Link busy (-17), Invalid profile (-16), Invalid mapping (-15), Read only param (-14), Msg mismatch (-13), Msg too long (-12), Attrib NA (-11), Attrib RO (-10), Attrib missing (-9), Timeout (-8), In error (-7), Link num in use (-6), Not editable (-5), Invalid link num (-4), Invalid args (-3), Too many links (-2), Out of memory (-1), OK (0), Not running (1), OK sync (2)						RO	Txt	ND	NC	PT	
4.10.040	Rx1 Link Profile	Std (0), Sync (1)			Std (0)			RW	Txt				US
4.10.041	Rx1 Link Number	0 to 255			0			RW	Num				US
4.10.042	Rx1 Destination Parameter	0.00.000 to 4.99.999			0.00.000			RW	SMP				US

Parameter	Range			Default			Type						
	OL	RFC-A	RFC-S	OL	RFC-A	RFC-S							
4.10.043	Rx1 Parameter Count	0 to 10			0			RW	Num				US
4.10.044	Rx1 Source Type	Direct (0), Multicast1 (1), Multicast2 (2), Multicast3 (3), Multicast4 (4), Local (5), Multicast5 (6), Multicast6 (7), Multicast7 (8), Multicast8 (9), Multicast9 (10), Multicast10 (11)			Direct (0)			RW	Txt				US
4.10.045	Rx1 Timeout	0 to 65535 ms			100 ms			RW	Num				US
4.10.046	Rx1 Timeout Action	Trip (0), Clear output (1), Hold last (2)			Trip (0)			RW	Txt				US
4.10.047	Rx1 Timeout Event Destination*	This slot (0), Slot 1 (1), Slot 2 (2), Slot 3 (3), Slot 4 (4)			This slot (0)			RW	Txt				US
4.10.048	Rx1 Timeout Event Type	No Event (0), Event (1), Event1 (2), Event2 (3), Event3 (4)			No Event (0)			RW	Txt				US
4.10.049	Rx1 Link Status	Disabled (-31), VLAN disabled (-30), Invalid DST IP (-22), SYNC unsupported (-21), MEC offset (-20), Invalid tx rate (-19), Too many mapping (-18), Link busy (-17), Invalid profile (-16), Invalid mapping (-15), Read only param (-14), Msg mismatch (-13), Msg too long (-12), Attrib NA (-11), Attrib RO (-10), Attrib missing (-9), Timeout (-8), In error (-7), Link num in use (-6), Not editable (-5), Invalid link num (-4), Invalid args (-3), Too many links (-2), Out of memory (-1), OK (0), Not running (1), OK sync (2)						RO	Txt	ND	NC	PT	
4.10.050	Rx2 Link Profile	Std (0), Sync (1)			Std (0)			RW	Txt				US
4.10.051	Rx2 Link Number	0 to 255			0			RW	Num				US
4.10.052	Rx2 Destination Parameter	0.00.000 to 4.99.999			0.00.000			RW	SMP				US
4.10.053	Rx2 Parameter Count	0 to 10			0			RW	Num				US
4.10.054	Rx2 Source Type	Direct (0), Multicast1 (1), Multicast2 (2), Multicast3 (3), Multicast4 (4), Local (5), Multicast5 (6), Multicast6 (7), Multicast7 (8), Multicast8 (9), Multicast9 (10), Multicast10 (11)			Direct (0)			RW	Txt				US
4.10.055	Rx2 Timeout	0 to 65535 ms			100 ms			RW	Num				US
4.10.056	Rx2 Timeout Action	Trip (0), Clear output (1), Hold last (2)			Trip (0)			RW	Txt				US
4.10.057	Rx2 Timeout Event Destination*	This slot (0), Slot 1 (1), Slot 2 (2), Slot 3 (3), Slot 4 (4)			This slot (0)			RW	Txt				US
4.10.058	Rx2 Timeout Event Type	No Event (0), Event (1), Event1 (2), Event2 (3), Event3 (4)			No Event (0)			RW	Txt				US
4.10.059	Rx2 Link Status	Disabled (-31), VLAN disabled (-30), Invalid DST IP (-22), SYNC unsupported (-21), MEC offset (-20), Invalid tx rate (-19), Too many mapping (-18), Link busy (-17), Invalid profile (-16), Invalid mapping (-15), Read only param (-14), Msg mismatch (-13), Msg too long (-12), Attrib NA (-11), Attrib RO (-10), Attrib missing (-9), Timeout (-8), In error (-7), Link num in use (-6), Not editable (-5), Invalid link num (-4), Invalid args (-3), Too many links (-2), Out of memory (-1), OK (0), Not running (1), OK sync (2)						RO	Txt	ND	NC	PT	
4.10.060	Rx3 Link Profile	Std (0), Sync (1)			Std (0)			RW	Txt				US
4.10.061	Rx3 Link Number	0 to 255			0			RW	Num				US
4.10.062	Rx3 Destination Parameter	0.00.000 to 4.99.999			0.00.000			RW	SMP				US
4.10.063	Rx3 Parameter Count	0 to 10			0			RW	Num				US
4.10.064	Rx3 Source Type	Direct (0), Multicast1 (1), Multicast2 (2), Multicast3 (3), Multicast4 (4), Local (5), Multicast5 (6), Multicast6 (7), Multicast7 (8), Multicast8 (9), Multicast9 (10), Multicast10 (11)			Direct (0)			RW	Txt				US
4.10.065	Rx3 Timeout	0 to 65535 ms			100 ms			RW	Num				US
4.10.066	Rx3 Timeout Action	Trip (0), Clear output (1), Hold last (2)			Trip (0)			RW	Txt				US
4.10.067	Rx3 Timeout Event Destination*	This slot (0), Slot 1 (1), Slot 2 (2), Slot 3 (3), Slot 4 (4)			This slot (0)			RW	Txt				US
4.10.068	Rx3 Timeout Event Type	No Event (0), Event (1), Event1 (2), Event2 (3), Event3 (4)			No Event (0)			RW	Txt				US
4.10.069	Rx3 Link Status	Disabled (-31), VLAN disabled (-30), Invalid DST IP (-22), SYNC unsupported (-21), MEC offset (-20), Invalid tx rate (-19), Too many mapping (-18), Link busy (-17), Invalid profile (-16), Invalid mapping (-15), Read only param (-14), Msg mismatch (-13), Msg too long (-12), Attrib NA (-11), Attrib RO (-10), Attrib missing (-9), Timeout (-8), In error (-7), Link num in use (-6), Not editable (-5), Invalid link num (-4), Invalid args (-3), Too many links (-2), Out of memory (-1), OK (0), Not running (1), OK sync (2)						RO	Txt	ND	NC	PT	

RW	Read / Write	RO	Read only	Num	Number parameter	Bit	Bit parameter	Txt	Text string	Bin	Binary parameter	FI	Filtered
ND	No default value	NC	Not copied	PT	Protected parameter	RA	Rating dependent	US	User save	PS	Power-down save	DE	Destination
IP	IP address	Mac	Mac address	Date	Date parameter	Time	Time parameter	SMP	Slot,menu,parameter	Chr	Character parameter	Ver	Version number

* This feature is not currently supported

12.28 Slot 4 Menu 11: Synchronization (Unidrive M700 / M702)

Parameter	Range			Default			Type					
	OL	RFC-A	RFC-S	OL	RFC-A	RFC-S	RW	Num	ND	NC	PT	US
4.11.001 Preferred Sync Master	0 to 4			1			RW	Num				US
4.11.002 Master Clock Domain	0 to 3			0			RW	Num				US
4.11.005 Grandmaster MAC Address	00:00:00:00:00:00 to FF:FF:FF:FF:FF:FF						RO	Mac	ND	NC	PT	
4.11.006 Synchronisation Jitter From Grandmaster	-2147483648 to 2147483647 ns						RO	Num	ND	NC	PT	
4.11.007 Synchronisation Jitter Threshold	500 to 1000000 ns			1000 ns			RW	Num				US
4.11.008 Module Synchronised Flag	Off (0) or On (1)			Off (0)			RO	Bit				
4.11.009 Inhibit Drive Synchronisation	Off (0) or On (1)			Off (0)			RW	Bit				US
4.11.010 PTP Date	00-00-00 to 31-12-99						RO	Date	ND	NC	PT	
4.11.011 PTP Time	00:00:00 to 23:59:59						RO	Time	ND	NC	PT	
4.11.015 PTP Delay Measurement Select	P2P DELAY (1), OFF (2)			P2P DELAY (1)			RW	Txt				US
4.11.016 PTP Sync Rate	-4 to 0			-4			RW	Num				US
4.11.017 In sync window length	3 to 255 s			20 s			RW	Num				US
4.11.020 Network Error Count	0 to 4294967295						RO	Num	ND	NC	PT	
4.11.022 Interoption Sync Status	MASTER (0), PRODUCER (1), INDEPENDENT (2)						RO	Txt	ND	NC	PT	
4.11.030 Easy Mode Maximum Network Delay	1 to 100 ms			3 ms			RW	Num				US
4.11.040 Rx1 Late Synchronisation Frame Action	Trip (1), Do not use (2), Use (3)			Trip (1)			RW	Txt				US
4.11.041 Rx1 Late Synchronisation Frame Destination*	This slot (0), Slot 1 (1), Slot 2 (2), Slot 3 (3), Slot 4 (4)			This slot (0)			RW	Txt				US
4.11.042 Rx1 Late Synchronisation Frame Event	No Event (0), Event (1), Event1 (2), Event2 (3), Event3 (4)			No Event (0)			RW	Txt				US
4.11.050 Rx2 Late Synchronisation Frame Action	Trip (1), Do not use (2), Use (3)			Trip (1)			RW	Txt				US
4.11.051 Rx2 Late Synchronisation Frame Destination*	This slot (0), Slot 1 (1), Slot 2 (2), Slot 3 (3), Slot 4 (4)			This slot (0)			RW	Txt				US
4.11.052 Rx2 Late Synchronisation Frame Event	No Event (0), Event (1), Event1 (2), Event2 (3), Event3 (4)			No Event (0)			RW	Txt				US
4.11.060 Rx3 Late Synchronisation Frame Action	Trip (1), Do not use (2), Use (3)			Trip (1)			RW	Txt				US
4.11.061 Rx3 Late Synchronisation Frame Destination*	This slot (0), Slot 1 (1), Slot 2 (2), Slot 3 (3), Slot 4 (4)			This slot (0)			RW	Txt				US
4.11.062 Rx3 Late Synchronisation Frame Event	No Event (0), Event (1), Event1 (2), Event2 (3), Event3 (4)			No Event (0)			RW	Txt				US

RW	Read / Write	RO	Read only	Num	Number parameter	Bit	Bit parameter	Txt	Text string	Bin	Binary parameter	FI	Filtered
ND	No default value	NC	Not copied	PT	Protected parameter	RA	Rating dependent	US	User save	PS	Power-down save	DE	Destination
IP	IP address	Mac	Mac address	Date	Date parameter	Time	Time parameter	SMP	Slot,menu,parameter	Chr	Character parameter	Ver	Version number

* This feature is not currently supported

12.29 Slot 4 Menu 15: Modbus TCP/IP Set-up (Unidrive M700 / M702)

Parameter	Range			Default			Type						
	OL	RFC-A	RFC-S	OL	RFC-A	RFC-S							
4.15.001	Enable	Off (0) or On (1)			On (1)			RW	Bit				US
4.15.002	Reset	Off (0) or On (1)			Off (0)			RW	Bit		NC		
4.15.003	Default	Off (0) or On (1)			Off (0)			RW	Bit		NC		
4.15.004	Modbus Configuration Error	No error (0), Port in use (1), Timeout event (2), Num Connections (3)						RO	Txt	ND	NC	PT	
4.15.005	Modbus Listening Port	0 to 65535			502			RW	Num				US
4.15.006	Maximum Connections	0 to 10			2			RW	Num				US
4.15.007	Maximum Priority Connections	0 to 5			0			RW	Num				US
4.15.008	Maximum Connections Per Client	1 to 4			2			RW	Num				US
4.15.009	Modbus Timeout	1 to 10000 ms			100 ms			RW	Num				US
4.15.010	Modbus Timeout Action	Trip (0), No action (1)			No action (1)			RW	Txt				US
4.15.011	Modbus Timeout Event Destination*	This slot (0), Slot 1 (1), Slot 2 (2), Slot 3 (3), Slot 4 (4)			This slot (0)			RW	Txt				US
4.15.012	Modbus Timeout Event Type	No event (0), Trigger Event (1), Trigger Event 1 (2), Trigger Event 2 (3), Trigger Event 3 (4), Trigger Event 4 (5)			No event (0)			RW	Txt				US
4.15.013	Modbus Resister Addressing Mode	Standard (0), Modified (1)			Standard (0)			RW	Txt				US
4.15.020	Priority Connection 1	0.0.0.0 to 255.255.255.255			0.0.0.0			RW	IP				US
4.15.021	Priority Connection 2	0.0.0.0 to 255.255.255.255			0.0.0.0			RW	IP				US
4.15.022	Priority Connection 3	0.0.0.0 to 255.255.255.255			0.0.0.0			RW	IP				US
4.15.023	Priority Connection 4	0.0.0.0 to 255.255.255.255			0.0.0.0			RW	IP				US

RW	Read / Write	RO	Read only	Num	Number parameter	Bit	Bit parameter	Txt	Text string	Bin	Binary parameter	FI	Filtered
ND	No default value	NC	Not copied	PT	Protected parameter	RA	Rating dependent	US	User save	PS	Power-down save	DE	Destination
IP	IP address	Mac	Mac address	Date	Date parameter	Time	Time parameter	SMP	Slot,menu,parameter	Chr	Character parameter	Ver	Version number

* This feature is not currently supported

12.30 Slot 4 Menu 20: EtherNet/IP Set-up (Unidrive M700 / M702)

Parameter	Range			Default			Type						
	OL	RFC-A	RFC-S	OL	RFC-A	RFC-S	RW	Bit	ND	NC	PT	US	
4.20.001	Enable EtherNet/IP	Off (0) or On (1)			On (1)			RW	Bit				US
4.20.002	Reset	Off (0) or On (1)			Off (0)			RW	Bit		NC		
4.20.003	Default	Off (0) or On (1)			Off (0)			RW	Bit		NC		
4.20.004	Configuration error	No error (0), RPI event dst (1), RPI event type (2), IDLE event dst (3), IDLE event type (4), Input mapping (5), Output mapping (6), In cons trig pr (7), Out cons trig pr (8)						RO	Txt	ND	NC	PT	
4.20.007	Cyclic data transfers per second	0 to 65535 Messages/s						RO	Num	ND	NC	PT	
4.20.011	RPI timeout action	Trip (0), Send flt values (1), Clear output (2), Hold last (3), No Action (4)			Hold last (3)			RW	Txt				US
4.20.012	RPI timeout event destination*	This slot (0), Slot 1 (1), Slot 2 (2), Slot 3 (3), Slot 4 (4)			This slot (0)			RW	Txt				US
4.20.013	RPI timeout event type	No event (0), Trigger Event (1), Trigger Event 1 (2), Trigger Event 2 (3), Trigger Event 3 (4), Trigger Event 4 (5)			No event (0)			RW	Txt				US
4.20.015	PLC idle action	Trip (0), Send flt values (1), Clear output (2), Hold last (3), No Action (4)			No Action (4)			RW	Txt				US
4.20.016	PLC idle event destination*	This slot (0), Slot 1 (1), Slot 2 (2), Slot 3 (3), Slot 4 (4)			This slot (0)			RW	Txt				US
4.20.017	PLC idle event type	No event (0), Trigger Event (1), Trigger Event 1 (2), Trigger Event 2 (3), Trigger Event 3 (4), Trigger Event 4 (5)			No event (0)			RW	Txt				US
4.20.018	Active input assembly object	100-PrimaryI (0), 70-BscSpdCtrlI (1), 71-ExtSpdCtrlI (2), 72-SpdTqCtrlI (3), 73-ExtSpdTqCtrlI (4)						RO	Txt	ND	NC	PT	
4.20.019	Active output assembly object	101-PrimaryO (0), 20-BscSpdCtrlO (1), 21-ExtSpdCtrlO (2), 22-SpdTqCtrlO (3), 23-ExtSpdTqCtrlO (4)						RO	Txt	ND	NC	PT	
4.20.020	Input assembly object size	4 to 128 Bytes			8 Bytes			RW	Num				US
4.20.021	Output assembly object size	4 to 128 Bytes			8 Bytes			RW	Num				US
4.20.024	Input assembly object process time	0 to 65535 ms						RO	Num	ND	NC	PT	
4.20.025	Output assembly object process time	0 to 65535 ms						RO	Num	ND	NC	PT	
4.20.026	Input assembly object consistency enable	Off (0) or On (1)			Off (0)			RW	Bit				US
4.20.027	Input assembly object consistency trigger parameter	0.00.000 to 4.99.999			0.00.000			RW	SMP				US
4.20.028	Output assembly object consistency enable	Off (0) or On (1)			Off (0)			RW	Bit				US
4.20.029	Output assembly object consistency trigger parameter	0.00.000 to 4.99.999			0.00.000			RW	SMP				US
4.20.030	Custom Vendor ID	257 - CT (0), 553 - CT AMERICA (1)			257 - CT (0)			RW	Txt				US
4.20.031	Custom product code	0 to 65535			0			RW	Num				US
4.20.032	Custom product revision code	0 to 65535			0			RW	Num				US
4.20.033	Actual Product Code	0 to 65535						RO	Num	ND	NC	PT	
4.20.034	Actual Product Revision	0 to 65535						RO	Num	ND	NC	PT	
4.20.040	Type of Motor 1	2-FC DC (0), 6-WRI (1), 7-SCI (2), 9-Sin PM BL (3), 10-Trap PM BL (4)						RO	Txt			PT	US
4.20.041	Type of Motor 2	2-FC DC (0), 6-WRI (1), 7-SCI (2), 9-Sin PM BL (3), 10-Trap PM BL (4)						RO	Txt			PT	US

RW	Read / Write	RO	Read only	Num	Number parameter	Bit	Bit parameter	Txt	Text string	Bin	Binary parameter	FI	Filtered
ND	No default value	NC	Not copied	PT	Protected parameter	RA	Rating dependent	US	User save	PS	Power-down save	DE	Destination
IP	IP address	Mac	Mac address	Date	Date parameter	Time	Time parameter	SMP	Slot,menu,parameter	Chr	Character parameter	Ver	Version number

* This feature is not currently supported

12.31 Slot 4 Menu 21: EtherNet/IP In Mappings (Unidrive M700 / M702)

Parameter	Range			Default			Type						
	OL	RFC-A	RFC-S	OL	RFC-A	RFC-S							
4.21.001	Input Mapping Parameter 1	0.00.000 to 4.99.999			0.10.040			RW	SMP			PT	US
4.21.002	Input Mapping Parameter 2	0.00.000 to 4.99.999			0.02.001			RW	SMP			PT	US
4.21.003	Input Mapping Parameter 3	0.00.000 to 4.99.999			0.00.000			RW	SMP			PT	US
4.21.004	Input Mapping Parameter 4	0.00.000 to 4.99.999			0.00.000			RW	SMP			PT	US
4.21.005	Input Mapping Parameter 5	0.00.000 to 4.99.999			0.00.000			RW	SMP			PT	US
4.21.006	Input Mapping Parameter 6	0.00.000 to 4.99.999			0.00.000			RW	SMP			PT	US
4.21.007	Input Mapping Parameter 7	0.00.000 to 4.99.999			0.00.000			RW	SMP			PT	US
4.21.008	Input Mapping Parameter 8	0.00.000 to 4.99.999			0.00.000			RW	SMP			PT	US
4.21.009	Input Mapping Parameter 9	0.00.000 to 4.99.999			0.00.000			RW	SMP			PT	US
4.21.010	Input Mapping Parameter 10	0.00.000 to 4.99.999			0.00.000			RW	SMP			PT	US
4.21.011	Input Mapping Parameter 11	0.00.000 to 4.99.999			0.00.000			RW	SMP			PT	US
4.21.012	Input Mapping Parameter 12	0.00.000 to 4.99.999			0.00.000			RW	SMP			PT	US
4.21.013	Input Mapping Parameter 13	0.00.000 to 4.99.999			0.00.000			RW	SMP			PT	US
4.21.014	Input Mapping Parameter 14	0.00.000 to 4.99.999			0.00.000			RW	SMP			PT	US
4.21.015	Input Mapping Parameter 15	0.00.000 to 4.99.999			0.00.000			RW	SMP			PT	US
4.21.016	Input Mapping Parameter 16	0.00.000 to 4.99.999			0.00.000			RW	SMP			PT	US
4.21.017	Input Mapping Parameter 17	0.00.000 to 4.99.999			0.00.000			RW	SMP			PT	US
4.21.018	Input Mapping Parameter 18	0.00.000 to 4.99.999			0.00.000			RW	SMP			PT	US
4.21.019	Input Mapping Parameter 19	0.00.000 to 4.99.999			0.00.000			RW	SMP			PT	US
4.21.020	Input Mapping Parameter 20	0.00.000 to 4.99.999			0.00.000			RW	SMP			PT	US
4.21.021	Input Mapping Parameter 21	0.00.000 to 4.99.999			0.00.000			RW	SMP			PT	US
4.21.022	Input Mapping Parameter 22	0.00.000 to 4.99.999			0.00.000			RW	SMP			PT	US
4.21.023	Input Mapping Parameter 23	0.00.000 to 4.99.999			0.00.000			RW	SMP			PT	US
4.21.024	Input Mapping Parameter 24	0.00.000 to 4.99.999			0.00.000			RW	SMP			PT	US
4.21.025	Input Mapping Parameter 25	0.00.000 to 4.99.999			0.00.000			RW	SMP			PT	US
4.21.026	Input Mapping Parameter 26	0.00.000 to 4.99.999			0.00.000			RW	SMP			PT	US
4.21.027	Input Mapping Parameter 27	0.00.000 to 4.99.999			0.00.000			RW	SMP			PT	US
4.21.028	Input Mapping Parameter 28	0.00.000 to 4.99.999			0.00.000			RW	SMP			PT	US
4.21.029	Input Mapping Parameter 29	0.00.000 to 4.99.999			0.00.000			RW	SMP			PT	US
4.21.030	Input Mapping Parameter 30	0.00.000 to 4.99.999			0.00.000			RW	SMP			PT	US
4.21.031	Input Mapping Parameter 31	0.00.000 to 4.99.999			0.00.000			RW	SMP			PT	US
4.21.032	Input Mapping Parameter 32	0.00.000 to 4.99.999			0.00.000			RW	SMP			PT	US

RW	Read / Write	RO	Read only	Num	Number parameter	Bit	Bit parameter	Txt	Text string	Bin	Binary parameter	Fl	Filtered
ND	No default value	NC	Not copied	PT	Protected parameter	RA	Rating dependent	US	User save	PS	Power-down save	DE	Destination
IP	IP address	Mac	Mac address	Date	Date parameter	Time	Time parameter	SMP	Slot,menu,parameter	Chr	Character parameter	Ver	Version number

12.32 Slot 4 Menu 22: EtherNet/IP Out Mappings (Unidrive M700 / M702)

Parameter	Range	Default			Type								
		OL	RFC-A	RFC-S					OL	RFC-A	RFC-S		
4.22.001	Output Mapping Parameter 1	0.00.000 to 4.99.999			0.06.042			RW	SMP			PT	US
4.22.002	Output Mapping Parameter 2	0.00.000 to 4.99.999			0.01.021			RW	SMP			PT	US
4.22.003	Output Mapping Parameter 3	0.00.000 to 4.99.999			0.00.000			RW	SMP			PT	US
4.22.004	Output Mapping Parameter 4	0.00.000 to 4.99.999			0.00.000			RW	SMP			PT	US
4.22.005	Output Mapping Parameter 5	0.00.000 to 4.99.999			0.00.000			RW	SMP			PT	US
4.22.006	Output Mapping Parameter 6	0.00.000 to 4.99.999			0.00.000			RW	SMP			PT	US
4.22.007	Output Mapping Parameter 7	0.00.000 to 4.99.999			0.00.000			RW	SMP			PT	US
4.22.008	Output Mapping Parameter 8	0.00.000 to 4.99.999			0.00.000			RW	SMP			PT	US
4.22.009	Output Mapping Parameter 9	0.00.000 to 4.99.999			0.00.000			RW	SMP			PT	US
4.22.010	Output Mapping Parameter 10	0.00.000 to 4.99.999			0.00.000			RW	SMP			PT	US
4.22.011	Output Mapping Parameter 11	0.00.000 to 4.99.999			0.00.000			RW	SMP			PT	US
4.22.012	Output Mapping Parameter 12	0.00.000 to 4.99.999			0.00.000			RW	SMP			PT	US
4.22.013	Output Mapping Parameter 13	0.00.000 to 4.99.999			0.00.000			RW	SMP			PT	US
4.22.014	Output Mapping Parameter 14	0.00.000 to 4.99.999			0.00.000			RW	SMP			PT	US
4.22.015	Output Mapping Parameter 15	0.00.000 to 4.99.999			0.00.000			RW	SMP			PT	US
4.22.016	Output Mapping Parameter 16	0.00.000 to 4.99.999			0.00.000			RW	SMP			PT	US
4.22.017	Output Mapping Parameter 17	0.00.000 to 4.99.999			0.00.000			RW	SMP			PT	US
4.22.018	Output Mapping Parameter 18	0.00.000 to 4.99.999			0.00.000			RW	SMP			PT	US
4.22.019	Output Mapping Parameter 19	0.00.000 to 4.99.999			0.00.000			RW	SMP			PT	US
4.22.020	Output Mapping Parameter 20	0.00.000 to 4.99.999			0.00.000			RW	SMP			PT	US
4.22.021	Output Mapping Parameter 21	0.00.000 to 4.99.999			0.00.000			RW	SMP			PT	US
4.22.022	Output Mapping Parameter 22	0.00.000 to 4.99.999			0.00.000			RW	SMP			PT	US
4.22.023	Output Mapping Parameter 23	0.00.000 to 4.99.999			0.00.000			RW	SMP			PT	US
4.22.024	Output Mapping Parameter 24	0.00.000 to 4.99.999			0.00.000			RW	SMP			PT	US
4.22.025	Output Mapping Parameter 25	0.00.000 to 4.99.999			0.00.000			RW	SMP			PT	US
4.22.026	Output Mapping Parameter 26	0.00.000 to 4.99.999			0.00.000			RW	SMP			PT	US
4.22.027	Output Mapping Parameter 27	0.00.000 to 4.99.999			0.00.000			RW	SMP			PT	US
4.22.028	Output Mapping Parameter 28	0.00.000 to 4.99.999			0.00.000			RW	SMP			PT	US
4.22.029	Output Mapping Parameter 29	0.00.000 to 4.99.999			0.00.000			RW	SMP			PT	US
4.22.030	Output Mapping Parameter 30	0.00.000 to 4.99.999			0.00.000			RW	SMP			PT	US
4.22.031	Output Mapping Parameter 31	0.00.000 to 4.99.999			0.00.000			RW	SMP			PT	US
4.22.032	Output Mapping Parameter 32	0.00.000 to 4.99.999			0.00.000			RW	SMP			PT	US

RW	Read / Write	RO	Read only	Num	Number parameter	Bit	Bit parameter	Txt	Text string	Bin	Binary parameter	FI	Filtered
ND	No default value	NC	Not copied	PT	Protected parameter	RA	Rating dependent	US	User save	PS	Power-down save	DE	Destination
IP	IP address	Mac	Mac address	Date	Date parameter	Time	Time parameter	SMP	Slot,menu,parameter	Chr	Character parameter	Ver	Version number

12.33 Slot 4 Menu 23: EtherNet/IP Fault Values (Unidrive M700 / M702)

Parameter	Range			Default			Type						
	OL	RFC-A	RFC-S	OL	RFC-A	RFC-S							
4.23.001	Output Fault Value 1	-2147483648 to 2147483647			0			RW	Num			PT	US
4.23.002	Output Fault Value 2	-2147483648 to 2147483647			0			RW	Num			PT	US
4.23.003	Output Fault Value 3	-2147483648 to 2147483647			0			RW	Num			PT	US
4.23.004	Output Fault Value 4	-2147483648 to 2147483647			0			RW	Num			PT	US
4.23.005	Output Fault Value 5	-2147483648 to 2147483647			0			RW	Num			PT	US
4.23.006	Output Fault Value 6	-2147483648 to 2147483647			0			RW	Num			PT	US
4.23.007	Output Fault Value 7	-2147483648 to 2147483647			0			RW	Num			PT	US
4.23.008	Output Fault Value 8	-2147483648 to 2147483647			0			RW	Num			PT	US
4.23.009	Output Fault Value 9	-2147483648 to 2147483647			0			RW	Num			PT	US
4.23.010	Output Fault Value 10	-2147483648 to 2147483647			0			RW	Num			PT	US
4.23.011	Output Fault Value 11	-2147483648 to 2147483647			0			RW	Num			PT	US
4.23.012	Output Fault Value 12	-2147483648 to 2147483647			0			RW	Num			PT	US
4.23.013	Output Fault Value 13	-2147483648 to 2147483647			0			RW	Num			PT	US
4.23.014	Output Fault Value 14	-2147483648 to 2147483647			0			RW	Num			PT	US
4.23.015	Output Fault Value 15	-2147483648 to 2147483647			0			RW	Num			PT	US
4.23.016	Output Fault Value 16	-2147483648 to 2147483647			0			RW	Num			PT	US
4.23.017	Output Fault Value 17	-2147483648 to 2147483647			0			RW	Num			PT	US
4.23.018	Output Fault Value 18	-2147483648 to 2147483647			0			RW	Num			PT	US
4.23.019	Output Fault Value 19	-2147483648 to 2147483647			0			RW	Num			PT	US
4.23.020	Output Fault Value 20	-2147483648 to 2147483647			0			RW	Num			PT	US
4.23.021	Output Fault Value 21	-2147483648 to 2147483647			0			RW	Num			PT	US
4.23.022	Output Fault Value 22	-2147483648 to 2147483647			0			RW	Num			PT	US
4.23.023	Output Fault Value 23	-2147483648 to 2147483647			0			RW	Num			PT	US
4.23.024	Output Fault Value 24	-2147483648 to 2147483647			0			RW	Num			PT	US
4.23.025	Output Fault Value 25	-2147483648 to 2147483647			0			RW	Num			PT	US
4.23.026	Output Fault Value 26	-2147483648 to 2147483647			0			RW	Num			PT	US
4.23.027	Output Fault Value 27	-2147483648 to 2147483647			0			RW	Num			PT	US
4.23.028	Output Fault Value 28	-2147483648 to 2147483647			0			RW	Num			PT	US
4.23.029	Output Fault Value 29	-2147483648 to 2147483647			0			RW	Num			PT	US
4.23.030	Output Fault Value 30	-2147483648 to 2147483647			0			RW	Num			PT	US
4.23.031	Output Fault Value 31	-2147483648 to 2147483647			0			RW	Num			PT	US
4.23.032	Output Fault Value 32	-2147483648 to 2147483647			0			RW	Num			PT	US

RW	Read / Write	RO	Read only	Num	Number parameter	Bit	Bit parameter	Txt	Text string	Bin	Binary parameter	Fl	Filtered
ND	No default value	NC	Not copied	PT	Protected parameter	RA	Rating dependent	US	User save	PS	Power-down save	DE	Destination

12.34 Slot 4 Menu 24: Profinet Set-up (Unidrive M700 / M702)

Parameter	Range			Default			Type						
	OL	RFC-A	RFC-S	OL	RFC-A	RFC-S							
4.24.001	Enable Profinet Interface	Off (0) or On (1)			On (1)			RW	Bit				US
4.24.002	Reset Profinet	Off (0) or On (1)			Off (0)			RW	Bit		NC		
4.24.003	Profinet Default	Off (0) or On (1)			Off (0)			RW	Bit		NC		
4.24.004	Configuration Error	No Error (0), Input Mapping (1), Output Mapping (2), Data Size (3), Param Config (4)						RO	Txt		NC	PT	
4.24.005	Cyclic data transfers per second	0 to 65535 Messages/s						RO	Num	ND	NC	PT	
4.24.006	Revision Counter	0 to 65535						RO	Num	ND		PT	
4.24.007	Profile ID	0 to 65535			62976			RO	Num			PT	
4.24.008	Installation Date	00-00-00 to 31-12-99						RO	Date	ND		PT	
4.24.009	Profinet Timeout Value	0 to 10000			100			RO	Num			PT	
4.24.010	Profinet Timeout Action	Trip (0), Reserved (1), Clear output (2), Hold last (3), No Action (4)			No Action (4)			RW	Txt			PT	US
4.24.011	Timeout Event Destination*	This slot (0), Slot 1 (1), Slot 2 (2), Slot 3 (3), Slot 4 (4)			This slot (0)			RW	Txt			PT	US
4.24.012	Profinet Timeout Event Type*	No Event (0), Trigger Event (1), Trigger Event 1 (2), Trigger Event 2 (3), Trigger Event 3 (4), Trigger Event 4 (5)			No Event (0)			RW	Txt			PT	US
4.23.026	Profinet Input Consistency Enable	Off (0) or On (1)			Off (0)			RW	Bit				US
4.23.027	Profinet Input Consistency Trigger	0 to 499999			0			RW	SMP				US
4.23.028	Profinet Output Consistency Enable	Off (0) or On (1)			Off (0)			RW	Bit				US
4.24.029	Profinet Output Consistency Trigger	0 to 499999			0			RW	SMP				US

RW	Read / Write	RO	Read only	Num	Number parameter	Bit	Bit parameter	Txt	Text string	Bin	Binary parameter	FI	Filtered
ND	No default value	NC	Not copied	PT	Protected parameter	RA	Rating dependent	US	User save	PS	Power-down save	DE	Destination

* This feature is not currently supported

13 Diagnostics

The keypad display on the drive gives various information about the status of the drive. The keypad display provides information on the following categories:

- Trip indications
- Alarm indications
- Status indications



Users must not attempt to repair a drive if it is faulty, nor carry out fault diagnosis other than through the use of the diagnostic features described in this chapter. If a drive is faulty, it must be returned to an authorized Control Techniques distributor for repair.

13.1 Status modes (Keypad and LED status)

Figure 13-1 Keypad status modes

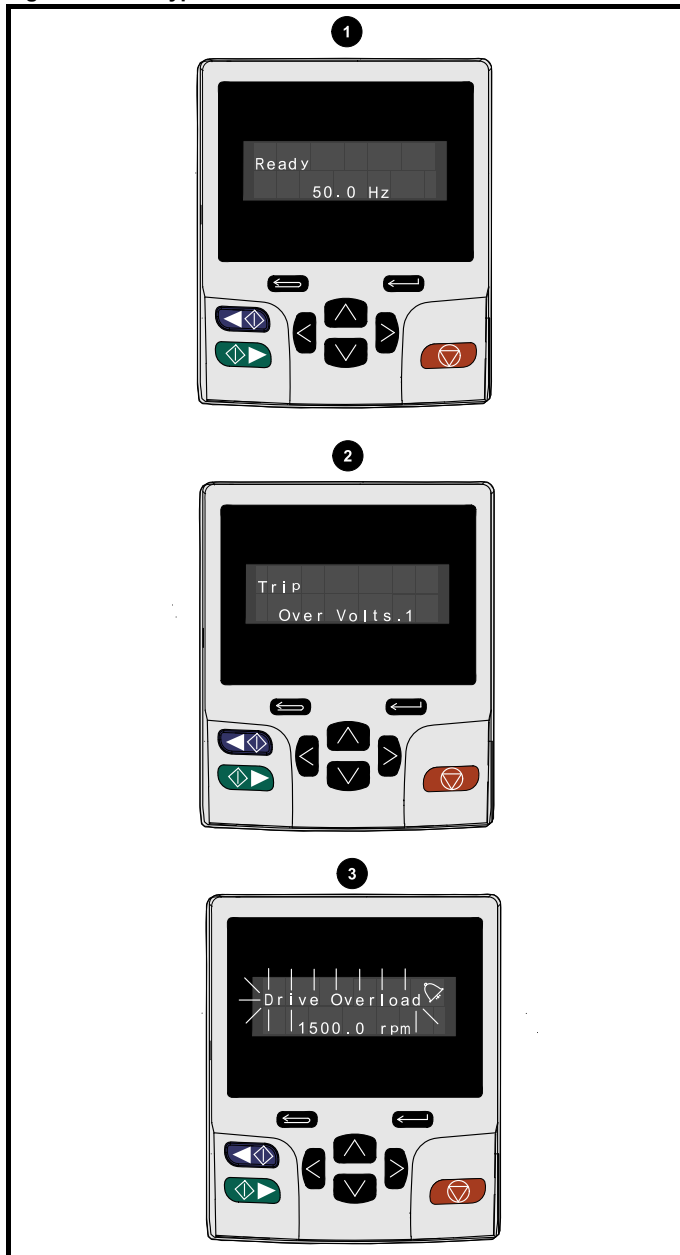

1. Drive OK status
2. Trip status
3. Alarm status

Figure 13-2 Location of the status LED

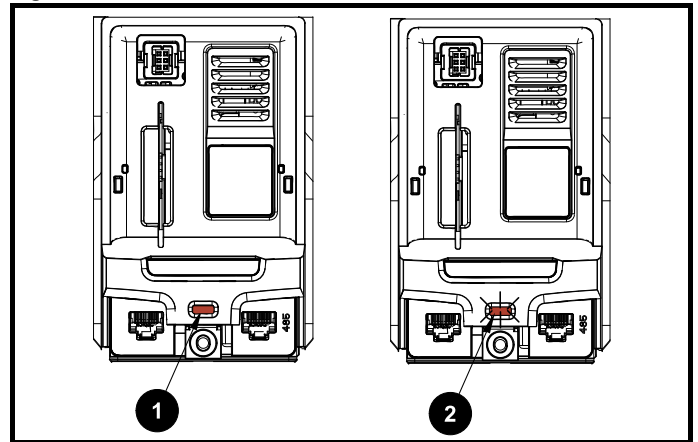

1. Non flashing: Normal status
2. Flashing: Trip status

13.1.1 Unidrive M700 / M702 Ethernet status LED

Each of the Ethernet ports provide a status LED for diagnostic and information purposes. Refer to Table 13-1 for Ethernet LED status.

Figure 13-3 Ethernet port status LED

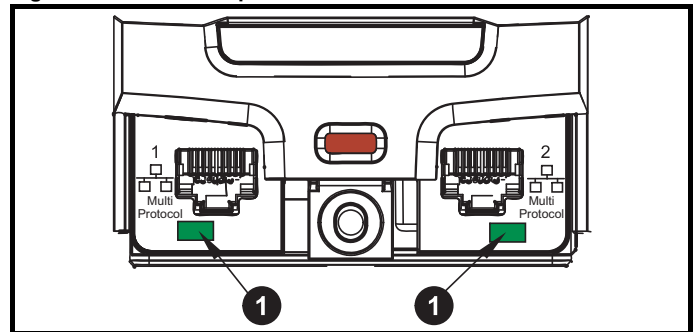

1. Ethernet port status LED.

Table 13-1 Ethernet LED status

LED status	Description
Off	Ethernet connection not detected
Solid green	Ethernet connection detected but no data
Flashing green	Ethernet connection detected and data flow

13.2 Trip indications

The output of the drive is disabled under any trip condition so that the drive stops controlling the motor. If the motor is running when the trip occurs it will coast to a stop.

During a trip condition, where a KI-Keypad is being used, the upper row of the display indicates that a trip has occurred and the lower row of the keypad display will display the trip string. Some trips have a sub-trip number to provide additional information about the trip. If a trip has a sub-trip number, the sub-trip number is flashed alternately with the trip string unless there is space on the second row for both the trip string and the sub-trip number in which case both the trip string and sub-trip information is displayed separated by a decimal place.

The back-light of the KI-Keypad display will also flash during a trip condition. If a display is not being used, the drive LED Status indicator will flash with 0.5 s duty cycle if the drive has tripped. Refer to Figure 13-2.

Trips are listed alphabetically in Table 13-4 based on the trip indication shown on the drive display. Alternatively, the drive status can be read in Pr 10.001 'Drive OK' using communication protocols. The most recent trip can be read in Pr 10.020 providing a trip number. It must be noted that the hardware trips (HF01 to HF20) do not have trip numbers. The

trip number must be checked in Table 13-5 to identify the specific trip.

Example

1. Trip code 2 is read from Pr 10.020 via serial communications.
2. Checking Table 13-4 shows Trip 2 is an Over Volts trip.

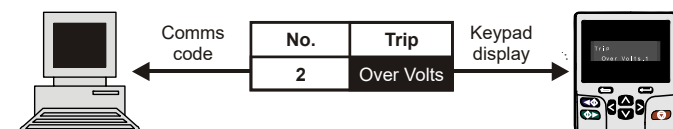

3. Look up Over Volts in Table 13-4.
4. Perform checks detailed under *Diagnosis*.

13.3 Identifying a trip / trip source

Some trips only contain a trip string whereas some other trips have a trip string along with a sub-trip number which provides the user with additional information about the trip.

A trip can be generated from a control system or from a power system. The sub-trip number associated with the trips listed in Table 13-2 is in the form xyyzz and used to identify the source of the trip.

Table 13-2 Trips associated with xyyzz sub-trip number

Over Volts	Oht dc bus
OI ac	Phase Loss
OI Brake	Power Comms
PSU	OI Snubber
Oht Inverter	Temp Feedback
Oht Power	Power Data
Oht Control	

The digits xx are 00 for a trip generated by the control system. For a single drive (not part of a multi-power module drive), if the trip is related to the power system then xx will have a value of 01, when displayed the leading zeros are suppressed.

The y digit is used to identify the location of a trip which is generated by a rectifier module connected to a power module (if xx is non zero). For a control system trip (xx is zero), the y digit, where relevant is defined for each trip. If not relevant, the y digit will have a value of zero.

The zz digits give the reason for the trip and are defined in each trip description.

Figure 13-4 Key to sub-trip number

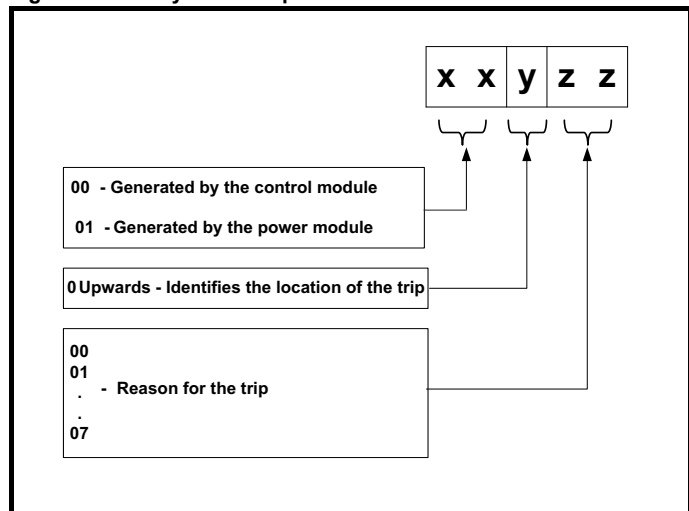

For example, if the drive has tripped and the lower line of the display shows 'Oht Control.2', with the help of Table 13-3 below the trip can be interpreted as; an over temperature has been detected; the trip was generated by fault in the control module, the control board thermistor 2 over temperature. For further information on individual sub-trips, refer to the diagnosis column in Table 13-4.

Table 13-3 Sub-trip identification

Source	xx	y	zz	Description
Control system	00	0	01	Control board thermistor 1 over temperature
Control system	00	0	02	Control board thermistor 2 over temperature
Control system	00	0	03	Control board thermistor 3 over temperature

13.4 Trips, Sub-trip numbers

Table 13-4 Trip indications

Trip	Diagnosis								
An Input 1 Loss	Analog input 1 current loss (Unidrive M700 / M701)								
28	<p><i>An Input 1 Loss</i> trip indicates that a current loss was detected in current mode on Analog input 1 (Terminal 5, 6). In 4-20 mA and 20-4 mA modes loss of input is detected if the current falls below 3 mA.</p> <p>Recommended actions:</p> <ul style="list-style-type: none"> • Check control wiring is correct • Check control wiring is undamaged • Check the <i>Analog Input 1 Mode</i> (07.007) • Current signal is present and greater than 3 mA 								
An Input 2 Loss	Analog input 2 current loss (Unidrive M700 / M701)								
29	<p><i>An Input 2 Loss</i> indicates that a current loss was detected in current mode on Analog input 2 (Terminal 7). In 4-20 mA and 20-4 mA modes loss of input is detected if the current falls below 3 mA.</p> <p>Recommended actions:</p> <ul style="list-style-type: none"> • Check control wiring is correct • Check control wiring is undamaged • Check the <i>Analog Input 2 Mode</i> (07.011) • Current signal is present and greater than 3 mA 								
An Output Calib	Analog output calibration failed (Unidrive M700 / M701)								
219	<p>The zero offset calibration of one or both of the analog outputs has failed. This indicates that the drive hardware has failed or a voltage is applied to the output via a low impedance, possibly due to a wiring error. The failed output can be identified by the sub-trip number.</p> <table border="1"> <thead> <tr> <th>Sub-trip</th> <th>Reason</th> </tr> </thead> <tbody> <tr> <td>1</td> <td>Output 1 failed (Terminal 9)</td> </tr> <tr> <td>2</td> <td>Output 2 failed (Terminal 10)</td> </tr> </tbody> </table> <p>Recommended actions:</p> <ul style="list-style-type: none"> • Check the wiring associated with analog outputs • Remove all the wiring that is connected to analog outputs and perform a re-calibration by power cycling the drive • If trip persists replace the drive 	Sub-trip	Reason	1	Output 1 failed (Terminal 9)	2	Output 2 failed (Terminal 10)		
Sub-trip	Reason								
1	Output 1 failed (Terminal 9)								
2	Output 2 failed (Terminal 10)								
App Menu Changed	Customization table for an application module has changed								
217	<p>The <i>App Menu Changed</i> trip indicates that the customization table for an application menu has changed. The menu that has been changed can be identified by the sub-trip number.</p> <table border="1"> <thead> <tr> <th>Sub-trip</th> <th>Reason</th> </tr> </thead> <tbody> <tr> <td>1</td> <td>Menu 18</td> </tr> <tr> <td>2</td> <td>Menu 19</td> </tr> <tr> <td>3</td> <td>Menu 20</td> </tr> </tbody> </table> <p>If more than one menu has changed the lowest menu has priority. Drive user parameters must be saved to prevent this trip on the next power-up.</p> <p>Recommended actions:</p> <ul style="list-style-type: none"> • Reset the trip and perform a parameter save to accept the new settings 	Sub-trip	Reason	1	Menu 18	2	Menu 19	3	Menu 20
Sub-trip	Reason								
1	Menu 18								
2	Menu 19								
3	Menu 20								

Trip	Diagnosis																								
Autotune 1	Position feedback did not change or required speed could not be reached																								
11	The drive has tripped during an autotune. The cause of the trip can be identified from the sub-trip number.																								
	<table border="1"> <thead> <tr> <th>Sub-trip</th> <th>Reason</th> <th>Recommended actions</th> </tr> </thead> <tbody> <tr> <td>1</td> <td>The position feedback did not change when position feedback is being used during rotating auto-tune.</td> <td>Ensure that the motor is free to turn (i.e. mechanical brake is released). Check that the position feedback is selected correctly and operates correctly.</td> </tr> <tr> <td>2</td> <td>The motor did not reach the required speed during mechanical load measurement.</td> <td>Ensure that the motor is free to turn and that the static load plus inertia is not too large for the drive to accelerate within the test time.</td> </tr> <tr> <td>3</td> <td>The required commutation signal edge could not be found during a rotating auto-tune with a Commutation Only position feedback device.</td> <td>Check that the position feedback signals are connected correctly.</td> </tr> <tr> <td>4</td> <td>The required movement angle cannot be produced during a minimal movement test.</td> <td>Reduce the angular movement required.</td> </tr> <tr> <td>5</td> <td>The second part of the minimal movement test during auto-tuning cannot locate the motor flux position accurately.</td> <td>Reduce the angular movement required.</td> </tr> <tr> <td>6</td> <td>The phasing offset angle is measured twice during a stationary auto-tune and the results are not within 30° of each other.</td> <td>If a minimal movement test is being used and excessive motor movement is occurring during the test reduce the required angle movement. Otherwise try and increase the required angle movement.</td> </tr> <tr> <td>7</td> <td>The motor is moving when a phasing test on enable is selected and the drive is enabled, but the motor is still moving at a speed above the zero speed threshold.</td> <td>Ensure that the motor is stationary before the drive is enabled.</td> </tr> </tbody> </table>	Sub-trip	Reason	Recommended actions	1	The position feedback did not change when position feedback is being used during rotating auto-tune.	Ensure that the motor is free to turn (i.e. mechanical brake is released). Check that the position feedback is selected correctly and operates correctly.	2	The motor did not reach the required speed during mechanical load measurement.	Ensure that the motor is free to turn and that the static load plus inertia is not too large for the drive to accelerate within the test time.	3	The required commutation signal edge could not be found during a rotating auto-tune with a Commutation Only position feedback device.	Check that the position feedback signals are connected correctly.	4	The required movement angle cannot be produced during a minimal movement test.	Reduce the angular movement required.	5	The second part of the minimal movement test during auto-tuning cannot locate the motor flux position accurately.	Reduce the angular movement required.	6	The phasing offset angle is measured twice during a stationary auto-tune and the results are not within 30° of each other.	If a minimal movement test is being used and excessive motor movement is occurring during the test reduce the required angle movement. Otherwise try and increase the required angle movement.	7	The motor is moving when a phasing test on enable is selected and the drive is enabled, but the motor is still moving at a speed above the zero speed threshold.	Ensure that the motor is stationary before the drive is enabled.
	Sub-trip	Reason	Recommended actions																						
	1	The position feedback did not change when position feedback is being used during rotating auto-tune.	Ensure that the motor is free to turn (i.e. mechanical brake is released). Check that the position feedback is selected correctly and operates correctly.																						
	2	The motor did not reach the required speed during mechanical load measurement.	Ensure that the motor is free to turn and that the static load plus inertia is not too large for the drive to accelerate within the test time.																						
	3	The required commutation signal edge could not be found during a rotating auto-tune with a Commutation Only position feedback device.	Check that the position feedback signals are connected correctly.																						
	4	The required movement angle cannot be produced during a minimal movement test.	Reduce the angular movement required.																						
	5	The second part of the minimal movement test during auto-tuning cannot locate the motor flux position accurately.	Reduce the angular movement required.																						
	6	The phasing offset angle is measured twice during a stationary auto-tune and the results are not within 30° of each other.	If a minimal movement test is being used and excessive motor movement is occurring during the test reduce the required angle movement. Otherwise try and increase the required angle movement.																						
	7	The motor is moving when a phasing test on enable is selected and the drive is enabled, but the motor is still moving at a speed above the zero speed threshold.	Ensure that the motor is stationary before the drive is enabled.																						
	Recommended actions:																								
<ul style="list-style-type: none"> • Ensure the motor is free to turn i.e. mechanical brake was released • Ensure Pr 03.026 and Pr 03.038 are set correctly (or appropriate 2nd motor map parameters) • Check feedback device wiring is correct • Check encoder mechanical coupling to the motor 																									
Autotune 2	Position feedback direction incorrect																								
12	The drive has tripped during a rotating autotune. The cause of the trip can be identified from the associated sub-trip number.																								
	<table border="1"> <thead> <tr> <th>Sub-trip</th> <th>Reason</th> </tr> </thead> <tbody> <tr> <td>1</td> <td>The position feedback direction is incorrect when position feedback is being used during a rotating autotune</td> </tr> <tr> <td>2</td> <td>A SINCOS encoder with comms is being used for position feedback and the comms position is rotating in the opposite direction to the sine wave based position.</td> </tr> </tbody> </table>	Sub-trip	Reason	1	The position feedback direction is incorrect when position feedback is being used during a rotating autotune	2	A SINCOS encoder with comms is being used for position feedback and the comms position is rotating in the opposite direction to the sine wave based position.																		
	Sub-trip	Reason																							
1	The position feedback direction is incorrect when position feedback is being used during a rotating autotune																								
2	A SINCOS encoder with comms is being used for position feedback and the comms position is rotating in the opposite direction to the sine wave based position.																								
Recommended actions:																									
<ul style="list-style-type: none"> • Check motor cable wiring is correct • Check feedback device wiring is correct • Swap any two motor phases 																									
Autotune 3	Measured inertia has exceeded the parameter range or commutation signals changed in wrong direction																								
13	The drive has tripped during a rotating autotune or mechanical load measurement test. The cause of the trip can be identified from the associated sub-trip number.																								
	<table border="1"> <thead> <tr> <th>Sub-trip</th> <th>Reason</th> </tr> </thead> <tbody> <tr> <td>1</td> <td>Measured inertia has exceeded the parameter range during a mechanical load measurement</td> </tr> <tr> <td>2</td> <td>The commutation signals changed in the wrong direction during a rotating autotune</td> </tr> <tr> <td>3</td> <td>The mechanical load test has been unable to identify the motor inertia.</td> </tr> </tbody> </table>	Sub-trip	Reason	1	Measured inertia has exceeded the parameter range during a mechanical load measurement	2	The commutation signals changed in the wrong direction during a rotating autotune	3	The mechanical load test has been unable to identify the motor inertia.																
	Sub-trip	Reason																							
	1	Measured inertia has exceeded the parameter range during a mechanical load measurement																							
2	The commutation signals changed in the wrong direction during a rotating autotune																								
3	The mechanical load test has been unable to identify the motor inertia.																								
Recommended actions for sub-trip 2:																									
<ul style="list-style-type: none"> • Check motor cable wiring is correct • Check feedback device U,V and W commutation signal wiring is correct 																									
Recommended actions for sub-trip 3:																									
<ul style="list-style-type: none"> • Increase the test level • If the test was carried out at standstill repeat the test with the motor rotating within the recommended speed range 																									

Trip	Diagnosis										
Autotune 4	Drive encoder U commutation signal fail										
14	A position feedback device with commutation signals is being used (i.e. AB Servo, FD Servo, FR Servo, SC Servo, or Commutations only encoder) and the U commutation signal did not change during a rotating autotune. Recommended actions: <ul style="list-style-type: none"> Check feedback device U commutation signal wiring is correct (Encoder terminals 7 and 8) 										
Autotune 5	Drive encoder V commutation signal fail										
15	A position feedback device with commutation signals is being used (i.e. AB Servo, FD Servo, FR Servo, SC Servo, or Commutations only encoder) and the V commutation signal did not change during a rotating autotune. Recommended actions: <ul style="list-style-type: none"> Check feedback device V commutation signal wiring is correct (Encoder terminals 9 and 10) 										
Autotune 6	Drive encoder W commutation signal fail										
16	A position feedback device with commutation signals is being used (i.e. AB Servo, FD Servo, FR Servo, SC Servo, or Commutations only encoder) and the W commutation signal did not change during a rotating autotune. Recommended actions: <ul style="list-style-type: none"> Check feedback device W commutation signal wiring is correct (Encoder terminals 11 and 12) 										
Autotune 7	Motor number of poles / position feedback resolution set incorrectly										
17	An <i>Autotune 7</i> trip is initiated during a rotating autotune, if the motor poles or the position feedback resolution have been set up incorrectly where position feedback is being used. Recommended actions: <ul style="list-style-type: none"> Check line per revolution for feedback device Check the number of poles in Pr 05.011 										
Autotune Stopped	Autotune test stopped before completion										
18	The drive was prevented from completing an autotune test, because either the drive enable or the drive run were removed. Recommended actions: <ul style="list-style-type: none"> Check the drive enable signal (terminal 31 on <i>Unidrive M700 / M701</i> and terminal 11 & 13 on <i>Unidrive M702</i>) was active during the autotune Check the run command was active in Pr 08.005 during autotune 										
Brake R Too Hot	Braking resistor overload timed out (I²t)										
19	The <i>Brake R Too Hot</i> indicates that braking resistor overload has timed out. The value in <i>Braking Resistor Thermal Accumulator</i> (10.039) is calculated using <i>Braking Resistor Rated Power</i> (10.030), <i>Braking Resistor Thermal Time Constant</i> (10.031) and <i>Braking Resistor Resistance</i> (10.061). The <i>Brake R Too Hot</i> trip is initiated when <i>Braking Resistor Thermal Accumulator</i> (10.039) reaches 100 %. Recommended actions: <ul style="list-style-type: none"> Ensure the values entered in Pr 10.030, Pr 10.031 and Pr 10.061 are correct If an external thermal protection device is being used and the braking resistor software overload protection is not required, set Pr 10.030, Pr 10.031 or Pr 10.061 to 0 to disable the trip. 										
CAM	Advanced motion controller CAM failure										
99	The <i>CAM</i> trip indicates that the advanced motion controller CAM has detected a problem. <table border="1" data-bbox="352 1346 1497 1566"> <thead> <tr> <th>Sub-trip</th> <th>Reason</th> </tr> </thead> <tbody> <tr> <td>1</td> <td><i>AMC Cam Start Index</i> (35.001) > <i>AMC Cam Size</i> (35.003) or <i>AMC Cam Start Position In Segment</i> (35.002) > Cam Table In for the start index</td> </tr> <tr> <td>2</td> <td><i>AMC CAM Index</i> (35.007) has been made to change by more than 2 in one sample</td> </tr> <tr> <td>3</td> <td>The rate of change at a segment boundary has exceeded the maximum value</td> </tr> <tr> <td>4</td> <td>The sum of the <i>AMC Cam Position In Segment</i> (35.008) and the change of master position has exceeded the maximum value.</td> </tr> </tbody> </table>	Sub-trip	Reason	1	<i>AMC Cam Start Index</i> (35.001) > <i>AMC Cam Size</i> (35.003) or <i>AMC Cam Start Position In Segment</i> (35.002) > Cam Table In for the start index	2	<i>AMC CAM Index</i> (35.007) has been made to change by more than 2 in one sample	3	The rate of change at a segment boundary has exceeded the maximum value	4	The sum of the <i>AMC Cam Position In Segment</i> (35.008) and the change of master position has exceeded the maximum value.
Sub-trip	Reason										
1	<i>AMC Cam Start Index</i> (35.001) > <i>AMC Cam Size</i> (35.003) or <i>AMC Cam Start Position In Segment</i> (35.002) > Cam Table In for the start index										
2	<i>AMC CAM Index</i> (35.007) has been made to change by more than 2 in one sample										
3	The rate of change at a segment boundary has exceeded the maximum value										
4	The sum of the <i>AMC Cam Position In Segment</i> (35.008) and the change of master position has exceeded the maximum value.										
Card Access	NV Media Card Write fail										
185	The <i>Card Access</i> trip indicates that the drive was unable to access the NV Media Card. If the trip occurs during the data transfer to the card then the file being written may be corrupted. If the trip occurs when the data being transferred to the drive then the data transfer may be incomplete. If a parameter file is transferred to the drive and this trip occurs during the transfer, the parameters are not saved to non-volatile memory, and so the original parameters can be restored by powering the drive down and up again. Recommended actions: <ul style="list-style-type: none"> Check NV Media Card is installed / located correctly Replace the NV Media Card 										

Trip	Diagnosis								
Card Boot	The Menu 0 parameter modification cannot be saved to the NV Media Card								
177	<p>Menu 0 changes are automatically saved on exiting edit mode.</p> <p>The <i>Card Boot</i> trip will occur if a write to a Menu 0 parameter has been initiated via the keypad by exiting edit mode and Pr 11.042 is set for auto or boot mode, but the necessary boot file has not been created on the NV Media Card to take the new parameter value. This occurs when Pr 11.042 is changed to Auto (3) or Boot (4) mode, but the drive is not subsequently reset. The action of resetting the trip will create the necessary file and prevent further trips.</p> <p>Recommended actions:</p> <ul style="list-style-type: none"> • Ensure that Pr 11.042 is correctly set, and then reset the drive to create the necessary file on the NV Media Card • Re-attempt the parameter write to the Menu 0 parameter 								
Card Busy	NV Media Card cannot be accessed as it is being accessed by an option module								
178	<p>The <i>Card Busy</i> trip indicates that an attempt has been made to access a file on NV Media Card, but the NV Media Card is already being accessed by an Option Module, such as one of the Applications modules. No data is transferred.</p> <p>Recommended actions:</p> <ul style="list-style-type: none"> • Wait for the option module to finish accessing the NV Media Card and re-attempt the required function 								
Card Compare	NV Media Card file/data is different to the one in the drive								
188	<p>A compare has been carried out between a file on the NV Media Card and the drive. A Card Compare trip is initiated if the parameters on the NV Media Card are different to the drive.</p> <p>Recommended actions:</p> <ul style="list-style-type: none"> • Set Pr mm.000 to 0 and reset the trip • Check to ensure the correct data block on the NV Media Card has been used for the compare. 								
Card Data Exists	NV Media Card data location already contains data								
179	<p>The <i>Card Data Exists</i> trip indicates that an attempt has been made to store data on a NV Media Card in a data block which already contains data. No data is transferred. The data should be erased from the card first to prevent this trip.</p> <p>Recommended actions:</p> <ul style="list-style-type: none"> • Erase the data in data location • Write data to an alternative data location 								
Card Drive Mode	NV Media Card parameter set not compatible with current drive mode								
187	<p>The <i>Card Drive Mode</i> trip is produced during a compare if the drive mode in the data block on the NV Media Card is different from the current drive mode. This trip is also produced if an attempt is made to transfer parameters from a NV Media Card to the drive if the operating mode in the data block is outside the allowed range of operating modes.</p> <p>Recommended actions:</p> <ul style="list-style-type: none"> • Ensure the destination drive supports the drive operating mode in the parameter file. • Clear the value in Pr mm.000 and reset the drive • Ensure destination drive operating mode is the same as the source parameter file 								
Card Error	NV Media Card data structure error								
182	<p>The <i>Card Error</i> trip indicates that an attempt has been made to access a NV Media Card but an error has been detected in the data structure on the card. Resetting the trip will cause the drive to erase and create the correct folder structure. The cause of the trip can be identified by the sub-trip.</p> <table border="1"> <thead> <tr> <th>Sub-trip</th> <th>Reason</th> </tr> </thead> <tbody> <tr> <td>1</td> <td>The required folder and file structure is not present</td> </tr> <tr> <td>2</td> <td>The <000> file is corrupted.</td> </tr> <tr> <td>3</td> <td>Two or more files in the <MCDV\> folder have the same file identification number.</td> </tr> </tbody> </table> <p>Recommended actions:</p> <ul style="list-style-type: none"> • Erase all the data blocks and re-attempt the process • Ensure the card is located correctly • Replace the NV Media Card 	Sub-trip	Reason	1	The required folder and file structure is not present	2	The <000> file is corrupted.	3	Two or more files in the <MCDV\> folder have the same file identification number.
Sub-trip	Reason								
1	The required folder and file structure is not present								
2	The <000> file is corrupted.								
3	Two or more files in the <MCDV\> folder have the same file identification number.								
Card Full	NV Media Card full								
184	<p>The <i>Card Full</i> trip indicates that an attempt has been made to create a data block on a NV Media Card, but there is not enough space left on the card.</p> <p>Recommended actions:</p> <ul style="list-style-type: none"> • Delete a data block or the entire NV Media Card to create space • Use a different NV Media Card 								
Card No Data	NV Media Card data not found								
183	<p>The <i>Card No Data</i> trip indicates that an attempt has been made to access non-existent file or block on a NV Media Card. No data is transferred.</p> <p>Recommended actions:</p> <ul style="list-style-type: none"> • Ensure data block number is correct 								

Trip	Diagnosis								
Card Option	NV Media Card trip; option modules installed are different between source drive and destination drive								
180	<p>The <i>Card Option</i> trip indicates that parameter data or default difference data is being transferred from a NV Media Card to the drive, but the option module categories are different between source and destination drives. This trip does not stop the data transfer, but is a warning that the data for the option modules that are different will be set to the default values and not the values from the card. This trip also applies if a compare is attempted between the data block and the drive.</p> <p>Recommended actions:</p> <ul style="list-style-type: none"> • Ensure the correct option modules are installed. • Ensure the option modules are in the same option module slot as the parameter set stored. • Press the red reset button to acknowledge that the parameters for one or more of the option modules installed will be at their default values • This trip can be suppressed by setting Pr mm.000 to 9666 and resetting the drive. 								
Card Product	NV Media Card data blocks are not compatible with the drive derivative								
175	<p>If <i>Drive Derivative</i> (11.028) or <i>Product Type</i> (11.063) are different between the source and target drives then this trip is initiated either at power-up or when the card is accessed. It will have one of the following sub-trip numbers:</p> <table border="1"> <thead> <tr> <th>Sub-trip</th> <th>Reason</th> </tr> </thead> <tbody> <tr> <td>1</td> <td>If <i>Drive Derivative</i> (11.028) is different between the source and target drives, this trip is initiated either at power-up or when the SD Card is accessed. Data is still transferred, since this is a warning trip; the trip can be suppressed by entering code 9666 in parameter xx.000, and resetting the drive (this applies the warning suppression flag to the card).</td> </tr> <tr> <td>2</td> <td>If <i>Product Type</i> (11.063) is different between the source and target drives or if corruption is detected in the parameter file, this trip is initiated either at power-up or when the SD Card is accessed. This trip can be reset but no data are transferred in either direction between the drive and the card.</td> </tr> <tr> <td>3</td> <td>A Unidrive SP parameter value was found that has no equivalent parameter on the destination drive. Data is still transferred, since this is a warning trip; the trip can be suppressed by entering code 9666 in Pr xx.000, and resetting the drive (this applies the warning suppression flag to the card).</td> </tr> </tbody> </table> <p>Recommended actions:</p> <ul style="list-style-type: none"> • Use a different NV Media Card • This trip can be suppressed by setting Pr mm.000 to 9666 and resetting the drive 	Sub-trip	Reason	1	If <i>Drive Derivative</i> (11.028) is different between the source and target drives, this trip is initiated either at power-up or when the SD Card is accessed. Data is still transferred, since this is a warning trip; the trip can be suppressed by entering code 9666 in parameter xx.000, and resetting the drive (this applies the warning suppression flag to the card).	2	If <i>Product Type</i> (11.063) is different between the source and target drives or if corruption is detected in the parameter file, this trip is initiated either at power-up or when the SD Card is accessed. This trip can be reset but no data are transferred in either direction between the drive and the card.	3	A Unidrive SP parameter value was found that has no equivalent parameter on the destination drive. Data is still transferred, since this is a warning trip; the trip can be suppressed by entering code 9666 in Pr xx.000 , and resetting the drive (this applies the warning suppression flag to the card).
Sub-trip	Reason								
1	If <i>Drive Derivative</i> (11.028) is different between the source and target drives, this trip is initiated either at power-up or when the SD Card is accessed. Data is still transferred, since this is a warning trip; the trip can be suppressed by entering code 9666 in parameter xx.000, and resetting the drive (this applies the warning suppression flag to the card).								
2	If <i>Product Type</i> (11.063) is different between the source and target drives or if corruption is detected in the parameter file, this trip is initiated either at power-up or when the SD Card is accessed. This trip can be reset but no data are transferred in either direction between the drive and the card.								
3	A Unidrive SP parameter value was found that has no equivalent parameter on the destination drive. Data is still transferred, since this is a warning trip; the trip can be suppressed by entering code 9666 in Pr xx.000 , and resetting the drive (this applies the warning suppression flag to the card).								
Card Rating	NV Media Card Trip; The voltage and / or current rating of the source and destination drives are different								
186	<p>The Card Rating trip indicates that parameter data is being transferred from a NV Media Card to the drive, but the current and / or voltage ratings are different between source and destination drives. This trip also applies if a compare (using Pr mm.000 set to 8yyy) is attempted between the data block on a NV Media Card and the drive. The Card Rating trip does not stop the data transfer but is a warning that rating specific parameters with the RA attribute may not be transferred to the destination drive.</p> <p>Recommended actions:</p> <ul style="list-style-type: none"> • Reset the drive to clear the trip • Ensure that the drive rating dependent parameters have transferred correctly • This trip can be suppressed by setting Pr mm.000 to 9666 and resetting the drive 								
Card Read Only	NV Media Card has the Read Only bit set								
181	<p>The <i>Card Read Only</i> trip indicates that an attempt has been made to modify a read-only NV Media Card or a read-only data block. A NV Media Card is read-only if the read-only flag has been set.</p> <p>Recommended actions:</p> <ul style="list-style-type: none"> • Clear the read only flag by setting Pr mm.000 to 9777 and reset the drive. This will clear the read-only flag for all data blocks in the NV Media Card 								
Card Slot	NV Media Card Trip; Option module application program transfer has failed								
174	<p>The <i>Card Slot</i> trip is initiated, if the transfer of an option module application program to or from an application module failed because the option module does not respond correctly. If this happens this trip is produced with the sub-trip indicating the option module slot number.</p> <p>Recommended actions:</p> <ul style="list-style-type: none"> • Ensure the source / destination option module is installed on the correct slot 								

Trip	Diagnosis								
Configuration	The number of power modules installed is different from the modules expected								
111	<p>The <i>Configuration</i> trip indicates that the <i>Number Of Power Modules Detected</i> (11.071) does not match the previous value stored. The sub-trip value indicates the number of power modules expected.</p> <p>Recommended actions:</p> <ul style="list-style-type: none"> • Ensure that all the power modules are correctly connected • Ensure all the power modules have powered up correctly • Ensure that the value in Pr 11.071 is set to the number of power modules connected • Set Pr 11.035 to 0 to disable the trip if it is not required <p>This trip is also initiated if the number of external rectifiers connected to each power module is less than the number defined by <i>Number Of Rectifiers Expected</i> (11.096). If this is the reason for the trip the sub-trip is 10x where x is the number of external rectifiers that should be connected.</p> <p>Recommended actions:</p> <ul style="list-style-type: none"> • Ensure that all the external rectifiers are connected correctly • Ensure that the value in <i>Number Of Rectifiers Expected</i> (11.096) is correct 								
Control Word	Trip initiated from the Control Word (06.042)								
35	<p>The Control Word trip is initiated by setting bit 12 on the control word in Pr 06.042 when the control word is enabled (Pr 06.043 = On).</p> <p>Recommended actions:</p> <ul style="list-style-type: none"> • Check the value of Pr 06.042. • Disable the control word in <i>Control Word Enable</i> (Pr 06.043) Bit 12 of the control word set to a one causes the drive to trip on Control Word When the control word is enabled, the trip can only be cleared by setting bit 12 to zero 								
Current Offset	Current feedback offset error								
225	<p>The current feedback offset is too large to be trimmed correctly. The sub-trip relates to the output phase for which the offset error has been detected.</p> <table border="1"> <thead> <tr> <th>Sub-trip</th> <th>Phase</th> </tr> </thead> <tbody> <tr> <td>1</td> <td>U</td> </tr> <tr> <td>2</td> <td>V</td> </tr> <tr> <td>3</td> <td>W</td> </tr> </tbody> </table> <p>Recommended actions:</p> <ul style="list-style-type: none"> • Ensure that there is no possibility of current flowing in the output phases of the drive when the drive is not enabled • Hardware fault – Contact the supplier of the drive 	Sub-trip	Phase	1	U	2	V	3	W
Sub-trip	Phase								
1	U								
2	V								
3	W								
Data Changing	Drive parameters are being changed								
97	<p>A user action or a file system write is active that is changing the drive parameters and the drive has been commanded to enable, i.e. <i>Drive Active</i> (10.002) = 1. The user actions that change drive parameters are loading defaults, changing drive mode, or transferring data from an NV memory card or a position feedback device to the drive. The file system actions that will cause this trip to be initiated if the drive is enabled during the transfer are writing a parameter or macro file to the drive, or transferring a derivative or user program to the drive. It should be noted that none of these actions can be started if the drive is active, and so the trip only occurs if the action is started and then the drive is enabled.</p> <p>Recommended actions:</p> <ul style="list-style-type: none"> • Ensure the drive is not enabled when one of the following is being carried out Loading defaults Changing drive mode Transferring data from NV Media Card or position feedback device Transferring user programs 								
Derivative ID	Derivative identification error								
247	<p>There is a problem with the identifier associated with derivative image which customizes the drive. The reason for the trip is given by the sub-trip as follows:</p> <table border="1"> <thead> <tr> <th>Sub-trip</th> <th>Reason</th> </tr> </thead> <tbody> <tr> <td>1</td> <td>There should be a derivative image in the product but this has been erased.</td> </tr> <tr> <td>2</td> <td>The identifier is out of range.</td> </tr> <tr> <td>3</td> <td>The derivative image has been changed.</td> </tr> </tbody> </table> <p>Recommended actions:</p> <p>Contact the supplier of the drive</p>	Sub-trip	Reason	1	There should be a derivative image in the product but this has been erased.	2	The identifier is out of range.	3	The derivative image has been changed.
Sub-trip	Reason								
1	There should be a derivative image in the product but this has been erased.								
2	The identifier is out of range.								
3	The derivative image has been changed.								

Trip	Diagnosis																														
Derivative Image	Derivative Image error																														
248	The <i>Derivative Image</i> trip indicates that an error has been detected in the derivative image. The sub-trip number indicates the reason for the trip.																														
	<table border="1"> <thead> <tr> <th>Sub-trip</th> <th>Reason</th> <th>Comments</th> </tr> </thead> <tbody> <tr> <td>1 to 52</td> <td>An error has been detected in the derivative image, contact the supplier of the drive.</td> <td></td> </tr> <tr> <td>61</td> <td>The option module fitted in slot 1 is not allowed with the derivative image</td> <td rowspan="4">Occurs when the drive powers-up or the image is programmed. The image tasks will not run.</td> </tr> <tr> <td>62</td> <td>The option module fitted in slot 2 is not allowed with the derivative image</td> </tr> <tr> <td>63</td> <td>The option module fitted in slot 3 is not allowed with the derivative image</td> </tr> <tr> <td>64</td> <td>The option module fitted in slot 4 is not allowed with the derivative image</td> </tr> <tr> <td>70</td> <td>An option module that is required by the derivative image is not fitted in any slot</td> <td rowspan="4">Occurs when the drive powers-up or the image is programmed. The image tasks will not run.</td> </tr> <tr> <td>71</td> <td>An option module specifically required to be fitted in slot 1 not present</td> </tr> <tr> <td>72</td> <td>An option module specifically required to be fitted in slot 2 not present</td> </tr> <tr> <td>73</td> <td>An option module specifically required to be fitted in slot 3 not present</td> </tr> <tr> <td>74</td> <td>An option module specifically required to be fitted in slot 4 not present</td> <td></td> </tr> <tr> <td>80 to 81</td> <td>An error has been detected in the derivative image, contact the supplier of the drive.</td> <td></td> </tr> </tbody> </table>	Sub-trip	Reason	Comments	1 to 52	An error has been detected in the derivative image, contact the supplier of the drive.		61	The option module fitted in slot 1 is not allowed with the derivative image	Occurs when the drive powers-up or the image is programmed. The image tasks will not run.	62	The option module fitted in slot 2 is not allowed with the derivative image	63	The option module fitted in slot 3 is not allowed with the derivative image	64	The option module fitted in slot 4 is not allowed with the derivative image	70	An option module that is required by the derivative image is not fitted in any slot	Occurs when the drive powers-up or the image is programmed. The image tasks will not run.	71	An option module specifically required to be fitted in slot 1 not present	72	An option module specifically required to be fitted in slot 2 not present	73	An option module specifically required to be fitted in slot 3 not present	74	An option module specifically required to be fitted in slot 4 not present		80 to 81	An error has been detected in the derivative image, contact the supplier of the drive.	
	Sub-trip	Reason	Comments																												
	1 to 52	An error has been detected in the derivative image, contact the supplier of the drive.																													
	61	The option module fitted in slot 1 is not allowed with the derivative image	Occurs when the drive powers-up or the image is programmed. The image tasks will not run.																												
	62	The option module fitted in slot 2 is not allowed with the derivative image																													
	63	The option module fitted in slot 3 is not allowed with the derivative image																													
	64	The option module fitted in slot 4 is not allowed with the derivative image																													
	70	An option module that is required by the derivative image is not fitted in any slot	Occurs when the drive powers-up or the image is programmed. The image tasks will not run.																												
	71	An option module specifically required to be fitted in slot 1 not present																													
	72	An option module specifically required to be fitted in slot 2 not present																													
	73	An option module specifically required to be fitted in slot 3 not present																													
	74	An option module specifically required to be fitted in slot 4 not present																													
	80 to 81	An error has been detected in the derivative image, contact the supplier of the drive.																													
Recommended action: Contact the supplier of the drive																															
Destination	Two or more parameters are writing to the same destination parameter																														
199	The Destination trip indicates that destination parameters of two or more functions (Menus 3, 7, 8, 9, 12 or 14) within the drive are writing to the same parameter. Recommended actions: <ul style="list-style-type: none"> Set Pr mm.000 to 'Destinations' or 12001 and check all visible parameters in all menus for parameter write conflicts 																														
Drive Size	Power stage recognition: Unrecognized drive size																														
224	The <i>Drive Size</i> trip indicates that the control PCB has not recognized the drive size of the power circuit to which it is connected. Recommended action: <ul style="list-style-type: none"> Ensure the drive is programmed to the latest firmware version Hardware fault - return drive to supplier 																														

Trip	Diagnosis																				
EEPROM Fail	Default parameters have been loaded																				
31	<p>The <i>EEPROM Fail</i> trip indicates that default parameters have been loaded. The exact cause/reason of the trip can be identified from the sub-trip number.</p> <table border="1"> <thead> <tr> <th>Sub-trip</th> <th>Reason</th> </tr> </thead> <tbody> <tr> <td>1</td> <td>The most significant digit of the internal parameter database version number has changed</td> </tr> <tr> <td>2</td> <td>The CRCs applied to the parameter data stored in internal non-volatile memory indicate that a valid set of parameters cannot be loaded</td> </tr> <tr> <td>3</td> <td>The drive mode restored from internal non-volatile memory is outside the allowed range for the product or the derivative image does not allow the previous drive mode</td> </tr> <tr> <td>4</td> <td>The drive derivative image has changed</td> </tr> <tr> <td>5</td> <td>The power stage hardware has changed</td> </tr> <tr> <td>6</td> <td>The internal I/O hardware has changed</td> </tr> <tr> <td>7</td> <td>The position feedback interface hardware has changed</td> </tr> <tr> <td>8</td> <td>The control board hardware has changed</td> </tr> <tr> <td>9</td> <td>The checksum on the non-parameter area of the EEPROM has failed</td> </tr> </tbody> </table> <p>The drive holds two banks of user save parameters and two banks of power down save parameters in non-volatile memory. If the last bank of either set of parameters that was saved is corrupted a <i>User Save</i> or <i>Power Down Save</i> trip is produced. If one of these trips occurs the parameters values that were last saved successfully are used. It can take some time to save parameters when requested by the user and if the power is removed from the drive during this process it is possible to corrupt the data in the non-volatile memory.</p> <p>If both banks of user save parameters or both banks of power down save parameters are corrupted or one of the other conditions given in the table above occurs EEPROM Fail.xxx trip is produced. If this trip occurs it is not possible to use the data that has been saved previously, and so the drive will be in lowest allowed drive mode with default parameters. The trip can only be reset if Pr mm.000 (mm.000) is set to 10, 11, 1233 or 1244 or if <i>Load Defaults</i> (11.043) is set to a non-zero value.</p> <p>Recommended actions:</p> <ul style="list-style-type: none"> • Default the drive and perform a reset • Allow sufficient time to perform a save before the supply to the drive is removed • If the trip persists - return drive to supplier 	Sub-trip	Reason	1	The most significant digit of the internal parameter database version number has changed	2	The CRCs applied to the parameter data stored in internal non-volatile memory indicate that a valid set of parameters cannot be loaded	3	The drive mode restored from internal non-volatile memory is outside the allowed range for the product or the derivative image does not allow the previous drive mode	4	The drive derivative image has changed	5	The power stage hardware has changed	6	The internal I/O hardware has changed	7	The position feedback interface hardware has changed	8	The control board hardware has changed	9	The checksum on the non-parameter area of the EEPROM has failed
	Sub-trip	Reason																			
	1	The most significant digit of the internal parameter database version number has changed																			
	2	The CRCs applied to the parameter data stored in internal non-volatile memory indicate that a valid set of parameters cannot be loaded																			
	3	The drive mode restored from internal non-volatile memory is outside the allowed range for the product or the derivative image does not allow the previous drive mode																			
	4	The drive derivative image has changed																			
	5	The power stage hardware has changed																			
	6	The internal I/O hardware has changed																			
	7	The position feedback interface hardware has changed																			
	8	The control board hardware has changed																			
9	The checksum on the non-parameter area of the EEPROM has failed																				
Encoder 1	Drive position feedback interface power supply overload																				
189	<p>The <i>Encoder 1</i> trip indicates that the drive encoder power supply has been overloaded. Terminals 13 & 14 of the 15 way D type connector can supply a maximum current of 200 mA @ 15 V or 300 mA @ 8 V and 5 V.</p> <p>Recommended actions:</p> <ul style="list-style-type: none"> • Check encoder power supply wiring • Disable the termination resistors (Pr 03.039 set to 0) to reduce current consumption • For 5 V encoders with long cables, select 8 V (Pr 03.036) and install a 5 V voltage regulator close to the encoder • Check the encoder specification to confirm if it is compatible with the encoder port power supply current capability • Replace the encoder • Use an external power supply with higher current capability 																				
Encoder 2	Drive encoder (Feedback) wire break																				
190	<p>The <i>Encoder 2</i> trip indicates that the drive has detected a wire break on the 15 way D-type connector on the drive. The exact cause of the trip can be identified from the sub-trip number.</p> <table border="1"> <thead> <tr> <th>Sub-trip</th> <th>Reason</th> </tr> </thead> <tbody> <tr> <td>1</td> <td>Drive position feedback interface 1 on any input</td> </tr> <tr> <td>2</td> <td>Drive position feedback interface 2 on any input</td> </tr> <tr> <td>11</td> <td>Drive position feedback interface 1 on the A channel</td> </tr> <tr> <td>12</td> <td>Drive position feedback interface 1 on the B channel</td> </tr> <tr> <td>13</td> <td>Drive position feedback interface 1 on the Z channel</td> </tr> </tbody> </table> <p>Recommended actions:</p> <ul style="list-style-type: none"> • Ensure that the position feedback device type selected in Pr 03.038 is correct for the position feedback device connected to the P1 interface on the drive. • If wire break detection on the drive encoder input is not required, set Pr 03.040 = XXX0 to disable the Encoder 2 trip • Check cable continuity • Check wiring of feedback signals is correct • Check encoder power supply is set correctly (Pr 03.036) • Replace encoder 	Sub-trip	Reason	1	Drive position feedback interface 1 on any input	2	Drive position feedback interface 2 on any input	11	Drive position feedback interface 1 on the A channel	12	Drive position feedback interface 1 on the B channel	13	Drive position feedback interface 1 on the Z channel								
	Sub-trip	Reason																			
	1	Drive position feedback interface 1 on any input																			
	2	Drive position feedback interface 2 on any input																			
	11	Drive position feedback interface 1 on the A channel																			
	12	Drive position feedback interface 1 on the B channel																			
13	Drive position feedback interface 1 on the Z channel																				

Trip	Diagnosis						
Encoder 3	Phase offset incorrect while running						
191	<p>The <i>Encoder 3</i> trip indicates that the drive has detected an incorrect UVW phase angle while running (RFC-S mode only) or SINCOS phase error. The feedback device which has caused the trip can be identified by the sub-trip number.</p> <table border="1"> <thead> <tr> <th>Sub-trip</th> <th>Reason</th> </tr> </thead> <tbody> <tr> <td>1</td> <td>Drive position feedback interface 1</td> </tr> <tr> <td>2</td> <td>Drive position feedback interface 2</td> </tr> </tbody> </table> <p>Recommended actions:</p> <ul style="list-style-type: none"> • Check encoder shield connections • Ensure the encoder cable is one uninterrupted cable • Check the encoder signal for noise with an oscilloscope • Check the integrity of the encoder mechanical mounting • For a UVW servo encoder, ensure that the phase rotation of the UVW commutation signals is the same as the phase rotation of the motor • For a SINCOS encoder, ensure that motor and incremental SINCOS connections are correct and that for forward rotation of the motor, the encoder rotates clockwise (when looking at the shaft of the encoder) • Repeat the offset measurement test 	Sub-trip	Reason	1	Drive position feedback interface 1	2	Drive position feedback interface 2
	Sub-trip	Reason					
1	Drive position feedback interface 1						
2	Drive position feedback interface 2						
Encoder 4	Feedback device comms failure						
192	<p>The Encoder 4 trip indicates that the encoder communications has timed out or the communications position message transfer time is too long. This trip can also be caused due to wire break in the communication channel between the drive and the encoder. The feedback device which has caused the trip can be identified by the sub-trip number.</p> <table border="1"> <thead> <tr> <th>Sub-trip</th> <th>Reason</th> </tr> </thead> <tbody> <tr> <td>1</td> <td>Drive position feedback interface 1</td> </tr> <tr> <td>2</td> <td>Drive position feedback interface 2</td> </tr> </tbody> </table> <p>Recommended actions:</p> <ul style="list-style-type: none"> • Ensure the encoder power supply setting (Pr 03.036) is correct • Complete encoder auto-configuration (Pr 03.041) • Check the encoder wiring • Replace the feedback device 	Sub-trip	Reason	1	Drive position feedback interface 1	2	Drive position feedback interface 2
	Sub-trip	Reason					
1	Drive position feedback interface 1						
2	Drive position feedback interface 2						
Encoder 5	Checksum or CRC error						
193	<p>The <i>Encoder 5</i> trip indicates that there is a checksum or CRC error, or the SSI encoder is not ready. The Encoder 5 trip can also indicate a wire break to a communications based encoder.</p> <table border="1"> <thead> <tr> <th>Sub-trip</th> <th>Reason</th> </tr> </thead> <tbody> <tr> <td>1</td> <td>Drive position feedback interface 1</td> </tr> <tr> <td>2</td> <td>Drive position feedback interface 2</td> </tr> </tbody> </table> <p>Recommended actions:</p> <ul style="list-style-type: none"> • Check the encoder cable shield connections • Ensure the cable is one uninterrupted cable - remove any connector blocks or if unavoidable minimise the length of any shield pigtailed to the connector block • Check the encoder signal for noise with an oscilloscope • Check the comms resolution setting (Pr 03.035) • If using a Hiperface, EnDat encoder carry out an encoder auto-configuration (Pr 03.041 = Enabled) • Replace the encoder 	Sub-trip	Reason	1	Drive position feedback interface 1	2	Drive position feedback interface 2
	Sub-trip	Reason					
1	Drive position feedback interface 1						
2	Drive position feedback interface 2						
Encoder 6	Encoder has indicated an error						
194	<p>The <i>Encoder 6</i> trip indicates that the encoder has indicated an error or that the power supply has failed to an SSI encoder. The <i>Encoder 6</i> trip can also indicate a wire break to an SSI encoder.</p> <table border="1"> <thead> <tr> <th>Sub-trip</th> <th>Reason</th> </tr> </thead> <tbody> <tr> <td>1</td> <td>Drive position feedback interface 1</td> </tr> <tr> <td>2</td> <td>Drive position feedback interface 2</td> </tr> </tbody> </table> <p>Recommended actions:</p> <ul style="list-style-type: none"> • For SSI encoders, check the wiring and encoder power supply setting (Pr 03.036) • Replace the encoder / contact the supplier of the encoder 	Sub-trip	Reason	1	Drive position feedback interface 1	2	Drive position feedback interface 2
	Sub-trip	Reason					
1	Drive position feedback interface 1						
2	Drive position feedback interface 2						

Trip	Diagnosis																
Encoder 7	Set-up parameters for position feedback device have changed																
195	The <i>Encoder 7</i> trip indicates that the set-up parameters for position feedback device has changed. The feedback device which has caused the trip can be identified by the sub-trip number.																
	<table border="1"> <thead> <tr> <th>Sub-trip</th> <th>Reason</th> </tr> </thead> <tbody> <tr> <td>1</td> <td>Drive position feedback interface 1</td> </tr> <tr> <td>2</td> <td>Drive position feedback interface 2</td> </tr> </tbody> </table>	Sub-trip	Reason	1	Drive position feedback interface 1	2	Drive position feedback interface 2										
	Sub-trip	Reason															
1	Drive position feedback interface 1																
2	Drive position feedback interface 2																
<p>Recommended actions:</p> <ul style="list-style-type: none"> Reset the trip and perform a save. Ensure Pr 3.033 and Pr 03.035 are set correctly or carry out an encoder auto-configuration (Pr 03.041 = Enabled) 																	
Encoder 8	Position feedback interface has timed out																
196	The <i>Encoder 8</i> trip indicates that Position feedback interface communications time exceeds 250 μ s. The feedback device which has caused the trip can be identified by the sub-trip number.																
	<table border="1"> <thead> <tr> <th>Sub-trip</th> <th>Reason</th> </tr> </thead> <tbody> <tr> <td>1</td> <td>Drive position feedback interface 1</td> </tr> <tr> <td>2</td> <td>Drive position feedback interface 2</td> </tr> </tbody> </table>	Sub-trip	Reason	1	Drive position feedback interface 1	2	Drive position feedback interface 2										
	Sub-trip	Reason															
1	Drive position feedback interface 1																
2	Drive position feedback interface 2																
<p>Recommended actions:</p> <ul style="list-style-type: none"> Ensure the encoder is connected correctly Ensure that the encoder is compatible Increase baud rate 																	
Encoder 9	Position feedback is selected from a option module slot which does not have a feedback option module installed																
197	The <i>Encoder 9</i> trip indicates that position feedback source selected in Pr 03.026 (or Pr 21.021 for the second motor map) is not valid																
	<p>Recommended actions:</p> <ul style="list-style-type: none"> Check the setting of Pr 03.026 (or Pr 21.021 if the second motor parameters have been enabled) Ensure that the option slot selected in Pr 03.026 has a feedback option module installed 																
Encoder 12	Encoder could not be identified during auto-configuration																
162	The <i>Encoder 12</i> trip indicates that the drive is communicating with the encoder but the encoder type is not recognized.																
	<table border="1"> <thead> <tr> <th>Sub-trip</th> <th>Reason</th> </tr> </thead> <tbody> <tr> <td>1</td> <td>Drive position feedback interface 1</td> </tr> <tr> <td>2</td> <td>Drive position feedback interface 2</td> </tr> </tbody> </table>	Sub-trip	Reason	1	Drive position feedback interface 1	2	Drive position feedback interface 2										
	Sub-trip	Reason															
1	Drive position feedback interface 1																
2	Drive position feedback interface 2																
<p>Recommended actions:</p> <ul style="list-style-type: none"> Enter the encoder setup parameters manually Check to see the encoder supports auto-configuration 																	
Encoder 13	Data read from the encoder is out of range during auto-configuration																
163	The <i>Encoder 13</i> trip indicates that the data read from the encoder was out of the range during auto-configuration. No parameters will be modified with the data read from the encoder as a result of auto configuration. The tens in the sub-trip number indicate the interface number (i.e. 1 for P1 interface and 2 for P2 interface).																
	<table border="1"> <thead> <tr> <th>Sub-trip</th> <th>Reason</th> </tr> </thead> <tbody> <tr> <td>x1</td> <td>Rotary lines per revolution error</td> </tr> <tr> <td>x2</td> <td>Linear comms pitch error</td> </tr> <tr> <td>x3</td> <td>Linear line pitch error</td> </tr> <tr> <td>x4</td> <td>Rotary turns bits error</td> </tr> <tr> <td>x5</td> <td>Communications bits error</td> </tr> <tr> <td>x6</td> <td>Calculation time is too long</td> </tr> <tr> <td>x7</td> <td>Line delay measured is longer than 5 μs</td> </tr> </tbody> </table>	Sub-trip	Reason	x1	Rotary lines per revolution error	x2	Linear comms pitch error	x3	Linear line pitch error	x4	Rotary turns bits error	x5	Communications bits error	x6	Calculation time is too long	x7	Line delay measured is longer than 5 μ s
	Sub-trip	Reason															
	x1	Rotary lines per revolution error															
	x2	Linear comms pitch error															
	x3	Linear line pitch error															
	x4	Rotary turns bits error															
	x5	Communications bits error															
x6	Calculation time is too long																
x7	Line delay measured is longer than 5 μ s																
<p>Recommended actions:</p> <ul style="list-style-type: none"> Enter the encoder setup parameters manually Check to see the encoder supports auto-configuration 																	

Trip	Diagnosis								
Encoder 14	The data given in the additional configuration parameter for a position feedback interface is out of range								
164	<p>The Encoder 14 trip indicates that the data given in the additional configuration parameter for a position feedback interface is out of range. If the sub-trip number is one then the data is out of range in <i>P1 Additional Configuration</i> (03.074), or if the sub-trip number is 2 the data is out of range in <i>P2 Additional Configuration</i> (03.174). Not all position feedback devices use the additional configuration, but those that do are listed below.</p> <p>BiSS</p> <p>Range checking is applied to the turns padding (decimal digits 5-3) and position padding (decimal digits 2-0). If these give a padding value outside +/-16 then the trip is initiated. Note that in each case the most significant digit indicates left (0) or right (1) padding, and the least significant 2 digits indicate the number of bits</p>								
External Trip	An External trip is initiated								
6	<p>An <i>External Trip</i> has occurred. The cause of the trip can be identified from the sub trip number displayed after the trip string. See table below. An external trip can also be initiated by writing a value of 6 in Pr 10.038.</p> <table border="1"> <thead> <tr> <th>Sub-trip</th> <th>Reason</th> </tr> </thead> <tbody> <tr> <td>1</td> <td><i>External Trip Mode</i> (08.010) = 1 or 3 and Safe Torque Off input 1 is low</td> </tr> <tr> <td>2</td> <td><i>External Trip Mode</i> (08.010) = 2 or 3 and Safe Torque Off input 2 is low</td> </tr> <tr> <td>3</td> <td><i>External Trip</i> (10.032) = 1</td> </tr> </tbody> </table> <p>Recommended actions:</p> <ul style="list-style-type: none"> • Check the Safe Torque Off signal voltage (on terminal 31 on <i>Unidrive M700 / M701</i> and terminal 11 & 13 on <i>Unidrive M702</i>) equals to 24 V. • Check the value of Pr 08.009 which indicates the digital state of terminal 31 on <i>Unidrive M700 / M701</i> and terminal 11 & 13 on <i>Unidrive M702</i>, equates to 'on'. • If external trip detection of the Safe Torque Off input is not required, set Pr 08.010 to OFF (0). • Check the value of Pr 10.032. • Select 'Destinations' (or enter 12001) in Pr mm.000 and check for a parameter controlling Pr 10.032. • Ensure Pr 10.032 or Pr 10.038 (= 6) is not being controlled by serial comms 	Sub-trip	Reason	1	<i>External Trip Mode</i> (08.010) = 1 or 3 and Safe Torque Off input 1 is low	2	<i>External Trip Mode</i> (08.010) = 2 or 3 and Safe Torque Off input 2 is low	3	<i>External Trip</i> (10.032) = 1
Sub-trip	Reason								
1	<i>External Trip Mode</i> (08.010) = 1 or 3 and Safe Torque Off input 1 is low								
2	<i>External Trip Mode</i> (08.010) = 2 or 3 and Safe Torque Off input 2 is low								
3	<i>External Trip</i> (10.032) = 1								
HF01	Data processing error: CPU address error								
	<p>The <i>HF01</i> trip indicates that a CPU address error has occurred. This trip indicates that the control PCB on the drive has failed.</p> <p>Recommended actions:</p> <ul style="list-style-type: none"> • Hardware fault – Contact the supplier of the drive 								
HF02	Data processing error: DMAC address error								
	<p>The <i>HF02</i> trip indicates that a DMAC address error has occurred. This trip indicates that the control PCB on the drive has failed.</p> <p>Recommended actions:</p> <ul style="list-style-type: none"> • Hardware fault – Contact the supplier of the drive 								
HF03	Data processing error: Illegal instruction								
	<p>The <i>HF03</i> trip indicates that an illegal instruction has occurred. This trip indicates that the control PCB on the drive has failed.</p> <p>Recommended actions:</p> <ul style="list-style-type: none"> • Hardware fault – Contact the supplier of the drive 								
HF04	Data processing error: Illegal slot instruction								
	<p>The <i>HF04</i> trip indicates that an illegal slot instruction has occurred. This trip indicates that the control PCB on the drive has failed.</p> <p>Recommended actions:</p> <ul style="list-style-type: none"> • Hardware fault – Contact the supplier of the drive 								
HF05	Data processing error: Undefined exception								
	<p>The <i>HF05</i> trip indicates that an undefined exception error has occurred. This trip indicates that the control PCB on the drive has failed.</p> <p>Recommended actions:</p> <ul style="list-style-type: none"> • Hardware fault – Contact the supplier of the drive 								
HF06	Data processing error: Reserved exception								
	<p>The <i>HF06</i> trip indicates that a reserved exception error has occurred. This trip indicates that the control PCB on the drive has failed.</p> <p>Recommended actions:</p> <ul style="list-style-type: none"> • Hardware fault – Contact the supplier of the drive 								

Trip	Diagnosis								
HF07	Data processing error: Watchdog failure The <i>HF07</i> trip indicates that a watchdog failure has occurred. This trip indicates that the control PCB on the drive has failed. Recommended actions: <ul style="list-style-type: none"> Hardware fault – Contact the supplier of the drive 								
HF08	Data processing error: CPU interrupt crash The <i>HF08</i> trip indicates that a CPU interrupt crash has occurred. This trip indicates that the control PCB on the drive has failed. Recommended actions: <ul style="list-style-type: none"> Hardware fault – Contact the supplier of the drive 								
HF09	Data processing error: Free store overflow The <i>HF09</i> trip indicates that a free store overflow has occurred. This trip indicates that the control PCB on the drive has failed. Recommended actions: <ul style="list-style-type: none"> Hardware fault – Contact the supplier of the drive 								
HF10	Data processing error: Parameter routing system error The <i>HF10</i> trip indicates that a Parameter routing system error has occurred. This trip indicates that the control PCB on the drive has failed. Recommended actions: <ul style="list-style-type: none"> Hardware fault – Contact the supplier of the drive 								
HF11	Data processing error: Access to EEPROM failed The <i>HF11</i> trip indicates that access to the drive EEPROM has failed. This trip indicates that the control PCB on the drive has failed. Recommended actions: <ul style="list-style-type: none"> Hardware fault – Contact the supplier of the drive 								
HF12	Data processing error: Main program stack overflow The <i>HF12</i> trip indicates that the main program stack over flow has occurred. The stack can be identified by the sub-trip number. This trip indicates that the control PCB on the drive has failed. <table border="1" data-bbox="316 1024 896 1167"> <thead> <tr> <th>Sub-trip</th> <th>Stack</th> </tr> </thead> <tbody> <tr> <td>1</td> <td>Background tasks</td> </tr> <tr> <td>2</td> <td>Timed tasks</td> </tr> <tr> <td>3</td> <td>Main system interrupts</td> </tr> </tbody> </table> Recommended actions: <ul style="list-style-type: none"> Hardware fault – Contact the supplier of the drive 	Sub-trip	Stack	1	Background tasks	2	Timed tasks	3	Main system interrupts
Sub-trip	Stack								
1	Background tasks								
2	Timed tasks								
3	Main system interrupts								
HF13	Data processing error: Firmware incompatible with hardware The <i>HF13</i> trip indicates that the drive firmware is not compatible with the hardware. This trip indicates that the control PCB on the drive has failed. The sub-trip number gives the actual ID code of the control board hardware. Recommended actions: <ul style="list-style-type: none"> Re-program the drive with the latest version of the drive firmware for <i>Unidrive M700 / M701 / M702</i> Hardware fault – Contact the supplier of the drive 								
HF14	Data processing error: CPU register bank error The <i>HF14</i> trip indicates that a CPU register bank error has occurred. This trip indicates that the control PCB on the drive has failed. Recommended actions: <ul style="list-style-type: none"> Hardware fault – Contact the supplier of the drive 								
HF15	Data processing error: CPU divide error The <i>HF15</i> trip indicates that a CPU divide error has occurred. This trip indicates that the control PCB on the drive has failed. Recommended actions: <ul style="list-style-type: none"> Hardware fault – Contact the supplier of the drive 								
HF16	Data processing error: RTOS error The <i>HF16</i> trip indicates that a RTOS error has occurred. This trip indicates that the control PCB on the drive has failed. Recommended actions: <ul style="list-style-type: none"> Hardware fault – Contact the supplier of the drive 								

Trip	Diagnosis								
HF17	<p>Data processing error: Clock supplied to the control board is out of specification</p> <p>The <i>HF17</i> trip indicates that the clock supplied to the control board logic is out of specification. This trip indicates that the control PCB on the drive has failed.</p> <p>Recommended actions:</p> <ul style="list-style-type: none"> Hardware fault – Contact the supplier of the drive 								
HF18	<p>Data processing error: Internal flash memory has failed</p> <p>The <i>HF18</i> trip indicates that the internal flash memory has failed when writing option module parameter data. The reason for the trip can be identified by the sub-trip number.</p> <table border="1" style="width: 100%; border-collapse: collapse;"> <thead> <tr> <th style="text-align: center;">Sub-trip</th> <th style="text-align: center;">Reason</th> </tr> </thead> <tbody> <tr> <td style="text-align: center;">1</td> <td>Programming error while writing menu in flash</td> </tr> <tr> <td style="text-align: center;">2</td> <td>Erase flash block containing setup menus failed</td> </tr> <tr> <td style="text-align: center;">3</td> <td>Erase flash block containing application menus failed</td> </tr> </tbody> </table> <p>Recommended actions:</p> <ul style="list-style-type: none"> Hardware fault - Contact the supplier of the drive. 	Sub-trip	Reason	1	Programming error while writing menu in flash	2	Erase flash block containing setup menus failed	3	Erase flash block containing application menus failed
Sub-trip	Reason								
1	Programming error while writing menu in flash								
2	Erase flash block containing setup menus failed								
3	Erase flash block containing application menus failed								
HF19	<p>Data processing error: CRC check on the firmware has failed</p> <p>The <i>HF19</i> trip indicates that the CRC check on the drive firmware has failed.</p> <p>Recommended actions:</p> <ul style="list-style-type: none"> Re-program the drive Hardware fault - Contact the supplier of the drive 								
HF20	<p>Data processing error: ASIC is not compatible with the hardware</p> <p>The <i>HF20</i> trip indicates that the ASIC version is not compatible with the drive firmware. The ASIC version can be identified from the sub-trip number.</p> <p>Recommended actions:</p> <ul style="list-style-type: none"> Hardware fault - Contact the supplier of the drive 								
HF23 to HF25	<p>Hardware fault</p> <p>Recommended actions:</p> <ul style="list-style-type: none"> If this trip occurs please consult the drive supplier. 								

Trip	Diagnosis																				
Inductance	Inductance measurement out of range or motor saturation not detected																				
8	<p>This trip occurs in RFC-S mode when the drive has detected that the motor inductances are not suitable for the operation being attempted. The trip is either caused because the ratio or difference between Ld and Lq is too small or because the saturation characteristic of the motor cannot be measured.</p> <p>If the inductance ratio or difference is too small this is because one of the following conditions is true: $(No\text{-}load\ Lq\ (05.072) - Ld\ (05.024)) / Ld\ (05.024) < 0.1$ $(No\text{-}load\ Lq\ (05.072) - Ld\ (05.024)) < (K / Full\ Scale\ Current\ Kc\ (11.061))H$</p> <p>where:</p> <table border="1"> <thead> <tr> <th>Drive Rated voltage (11.033)</th> <th>K</th> </tr> </thead> <tbody> <tr> <td>200 V</td> <td>0.0073</td> </tr> <tr> <td>400 V</td> <td>0.0146</td> </tr> <tr> <td>575 V</td> <td>0.0174</td> </tr> <tr> <td>690 V</td> <td>0.0209</td> </tr> </tbody> </table> <p>If the saturation characteristic of the motor cannot be measured this is because when the flux in the motor is changed the measured value of Ld does change sufficiently due to saturation to be measured. When half of <i>Rated Current</i> (05.007) is applied in the d axis of the motor in each direction the inductance must fall change at least $(K / (2 \times Full\ Scale\ Current\ Kc\ (11.061)))$.</p> <p>The specific reasons for each of the sub-trips are given in the table below:</p> <table border="1"> <thead> <tr> <th>Sub-trip</th> <th>Reason</th> </tr> </thead> <tbody> <tr> <td>1</td> <td>The inductance ratio or difference is too small when the drive has been started in sensorless mode.</td> </tr> <tr> <td>2</td> <td>The saturation characteristic of the motor cannot be measured when the drive has been started in sensorless mode.</td> </tr> <tr> <td>3</td> <td>The inductance ratio or difference is too small when an attempt is made to determine the location of the motor flux during a stationary auto-tune in RFC-S mode. This trip is also produced when the inductance ratio or inductance difference is too small when carrying out a phasing test on starting in RFC-S mode. If position feedback is being used the measured value for <i>Position Feedback Phase Angle</i> (03.025) may not be reliable. Also the measured values of <i>Ld</i> (05.024) and <i>No-load Lq</i> (05.072) may not correspond to the d and q axis respectively.</td> </tr> <tr> <td>4</td> <td>The direction of the flux in the motor is detected by the change of inductance with different currents. This trip is initiated if the change cannot be detected when an attempt is made to perform a stationary auto-tune when position feedback is being used, or to perform a phasing test on starting in RFC-S mode.</td> </tr> </tbody> </table> <p>Recommended actions for sub-trip 1:</p> <ul style="list-style-type: none"> Ensure that <i>RFC Low Speed Mode</i> (05.064) is set to Non-salient (1), Current (2) or Current No test (3). <p>Recommended actions for sub-trip 2:</p> <ul style="list-style-type: none"> Ensure that <i>RFC Low Speed Mode</i> (05.064) is set to Non-salient (1), Current (2) or Current No test (3). <p>Recommended actions for sub-trip 3:</p> <ul style="list-style-type: none"> None. The trip acts as a warning. <p>Recommended actions for sub-trip 4:</p> <ul style="list-style-type: none"> Stationary autotune is not possible. Perform a minimal movement or rotating autotune. Phasing test on starting is not possible. Use a position feedback device with commutation signals or absolute position. 	Drive Rated voltage (11.033)	K	200 V	0.0073	400 V	0.0146	575 V	0.0174	690 V	0.0209	Sub-trip	Reason	1	The inductance ratio or difference is too small when the drive has been started in sensorless mode.	2	The saturation characteristic of the motor cannot be measured when the drive has been started in sensorless mode.	3	The inductance ratio or difference is too small when an attempt is made to determine the location of the motor flux during a stationary auto-tune in RFC-S mode. This trip is also produced when the inductance ratio or inductance difference is too small when carrying out a phasing test on starting in RFC-S mode. If position feedback is being used the measured value for <i>Position Feedback Phase Angle</i> (03.025) may not be reliable. Also the measured values of <i>Ld</i> (05.024) and <i>No-load Lq</i> (05.072) may not correspond to the d and q axis respectively.	4	The direction of the flux in the motor is detected by the change of inductance with different currents. This trip is initiated if the change cannot be detected when an attempt is made to perform a stationary auto-tune when position feedback is being used, or to perform a phasing test on starting in RFC-S mode.
	Drive Rated voltage (11.033)	K																			
	200 V	0.0073																			
	400 V	0.0146																			
	575 V	0.0174																			
	690 V	0.0209																			
	Sub-trip	Reason																			
	1	The inductance ratio or difference is too small when the drive has been started in sensorless mode.																			
2	The saturation characteristic of the motor cannot be measured when the drive has been started in sensorless mode.																				
3	The inductance ratio or difference is too small when an attempt is made to determine the location of the motor flux during a stationary auto-tune in RFC-S mode. This trip is also produced when the inductance ratio or inductance difference is too small when carrying out a phasing test on starting in RFC-S mode. If position feedback is being used the measured value for <i>Position Feedback Phase Angle</i> (03.025) may not be reliable. Also the measured values of <i>Ld</i> (05.024) and <i>No-load Lq</i> (05.072) may not correspond to the d and q axis respectively.																				
4	The direction of the flux in the motor is detected by the change of inductance with different currents. This trip is initiated if the change cannot be detected when an attempt is made to perform a stationary auto-tune when position feedback is being used, or to perform a phasing test on starting in RFC-S mode.																				
Inductor Too Hot	The regen inductor has overloaded																				
93	<p>In Regen mode, this trip indicates a regen inductor thermal overload based on the <i>Rated Current</i> (Pr 05.007) and the <i>Inductor Thermal Time Constant</i> (Pr 04.015). Pr 04.015 displays the inductor temperature as a percentage of the maximum value. The drive will trip on <i>Inductor Too Hot</i> when Pr 04.019 gets to 100 %.</p> <p>Recommended actions:</p> <ul style="list-style-type: none"> Check the load / current through the inductor has not changed. Ensure the <i>Rated Current</i> (Pr 05.007) is not zero. 																				
Inter-connect	Multi-Power module drive interconnection cable error																				
103	<p>The Inter-connect trip indicates a multi-power module drive interconnection cable error. The sub-trip "xx.0.00" indicates which power module has detected the fault where xx is the power module number. It should be noted that this trip is also initiated if the communication fails either when a rectifier signals a fault or a trip is reset. In this case, the sub-trip is the number of modules that are still communicating correctly.</p>																				

Trip	Diagnosis						
I/O Overload	Digital output overload						
26	<p>The <i>I/O Overload</i> trip indicates that the total current drawn from 24 V user supply or from the digital output has exceeded the limit. A trip is initiated if one or more of the following conditions:</p> <ul style="list-style-type: none"> • Maximum output current from one digital output is 100 mA. • The combined maximum output current from outputs 1 and 2 is 100 mA • The combined maximum output current from output 3 and +24 V output is 100 mA <p>Recommended actions:</p> <ul style="list-style-type: none"> • Check total loads on digital outputs • Check control wiring is correct • Check output wiring is undamaged 						
Island	Island condition detected in regen mode						
160	<p>The <i>Island</i> trip indicates that the AC mains is no longer present and the inverter would be an 'islanded' power supply if it continued to operate. The sub-trip indicates the reason for the trip.</p> <table border="1"> <thead> <tr> <th>Sub-trip</th> <th>Description</th> </tr> </thead> <tbody> <tr> <td>1</td> <td>Island detection system has been enabled and detected an island condition</td> </tr> <tr> <td>2</td> <td>The minimum synchronization voltage is non-zero and the supply voltage has been below this threshold and been simulating its own supply synchronization for more than 2.0 s.</td> </tr> </tbody> </table> <p>Recommended actions:</p> <ul style="list-style-type: none"> • Check the supply / supply connections to the regen drive 	Sub-trip	Description	1	Island detection system has been enabled and detected an island condition	2	The minimum synchronization voltage is non-zero and the supply voltage has been below this threshold and been simulating its own supply synchronization for more than 2.0 s.
Sub-trip	Description						
1	Island detection system has been enabled and detected an island condition						
2	The minimum synchronization voltage is non-zero and the supply voltage has been below this threshold and been simulating its own supply synchronization for more than 2.0 s.						
Keypad Mode	Keypad has been removed when the drive is receiving the speed reference from the keypad						
34	<p>The <i>Keypad Mode</i> trip indicates that the drive is in keypad mode [<i>Reference Selector</i> (01.014) = 4 or 6 or M2 reference selector (21.003 = 4 or 6 if motor map 2 is selected)] and the keypad has been removed or disconnected from the drive.</p> <p>Recommended actions:</p> <ul style="list-style-type: none"> • Re-install keypad and reset • Change <i>Reference Selector</i> (01.014) to select the reference from another source 						
Line Sync	Synchronization to the power supply has been lost						
39	<p>The <i>Line Sync</i> trip indicates that the inverter has lost the synchronization with the ac supply in Regen mode.</p> <p>Recommended actions:</p> <ul style="list-style-type: none"> • Check the supply / supply connections to the regen drive 						
Low Load	The load on the drive has fallen below the low load detection level						
38	<p>When the low load detector is active, the low load condition is detected when the <i>Percentage Load</i> (Pr 04.020) falls below the threshold defined by the <i>Low Load Detection Level</i> (Pr 04.027).</p> <p><i>Enable Trip On Low Load</i> (Pr 04.029) defines the action taken when low load is detected. If <i>Enable Trip On Low Load</i> (Pr 04.029) = 0, a Low Load warning is displayed and <i>Low Load Detected Alarm</i> (Pr 10.062) = 1. If <i>Enable Trip On Low Load</i> (Pr 04.029) = 1 no warning is given, but a Low Load trip is initiated.</p> <p>Recommended actions:</p> <ul style="list-style-type: none"> • Check the load on the motor has not changed 						
Motor Too Hot	Output current overload timed out (I^2t)						
20	<p>The <i>Motor Too Hot</i> trip indicates a motor thermal overload based on the <i>Rated Current</i> (Pr 05.007) and <i>Motor Thermal Time Constant</i> (Pr 04.015). Pr 04.019 displays the motor temperature as a percentage of the maximum value. The drive will trip on <i>Motor Too Hot</i> when Pr 04.019 gets to 100 %.</p> <p>Recommended actions:</p> <ul style="list-style-type: none"> • Ensure the load is not jammed / sticking • Check the load on the motor has not changed • If seen during an auto-tune test in RFC-S mode, ensure the motor <i>Rated Current</i> in Pr 05.007 is \leq Heavy duty current rating of the drive • Tune the <i>Rated Speed</i> (Pr 05.008) (RFC-A mode only) • Check feedback signal for noise • Ensure the motor rated current is not zero • This trip can be disabled and current limiting activated on the motor overload by setting thermal protection mode Pr 04.016 to 1. 						

Trip	Diagnosis																				
Name Plate	Electronic nameplate transfer has failed																				
176	The <i>Name Plate</i> trip is initiated if an electronic name plate transfer between the drive and the motor has failed. The exact reason for the trip can be identified from the sub-trip number.																				
	<table border="1"> <thead> <tr> <th>Sub-trip</th> <th>Reason</th> </tr> </thead> <tbody> <tr> <td>1</td> <td>Not enough memory space to complete the transfer</td> </tr> <tr> <td>2</td> <td>Communication with encoder failed</td> </tr> <tr> <td>3</td> <td>The transfer has failed</td> </tr> <tr> <td>4</td> <td>The checksum of the stored object has failed</td> </tr> </tbody> </table>	Sub-trip	Reason	1	Not enough memory space to complete the transfer	2	Communication with encoder failed	3	The transfer has failed	4	The checksum of the stored object has failed										
	Sub-trip	Reason																			
	1	Not enough memory space to complete the transfer																			
	2	Communication with encoder failed																			
3	The transfer has failed																				
4	The checksum of the stored object has failed																				
Recommended actions:																					
<ul style="list-style-type: none"> • Ensure that the device encoder memory has at least 128 bytes to store the nameplate data • When writing the motor object (Pr mm.000 = 11000), ensure that the device encoder memory has at least 256 bytes to store all the nameplate data. • When transferring between option module and encoder, ensure that the option slot has a feedback option module installed. • Check if the encoder has been initialized in <i>Position Feedback Initialized</i> (03.076). • Verify the encoder wiring. 																					
Oht Brake	Braking IGBT over-temperature																				
101	The <i>Oht Brake</i> over-temperature trip indicates that braking IGBT over-temperature has been detected based on software thermal model.																				
	Recommended actions:																				
	<ul style="list-style-type: none"> • Check braking resistor value is greater than or equal to the minimum resistance value 																				
Oht Control	Control stage over temperature																				
23	This <i>Oht Control</i> trip indicates that a control stage over-temperature has been detected. From the sub-trip 'xyzz', the Thermistor location is identified by 'zz'.																				
	<table border="1"> <thead> <tr> <th>Source</th> <th>xx</th> <th>y</th> <th>zz</th> <th>Description</th> </tr> </thead> <tbody> <tr> <td>Control system</td> <td>00</td> <td>0</td> <td>01</td> <td>Control board thermistor 1 over temperature</td> </tr> <tr> <td>Control system</td> <td>00</td> <td>0</td> <td>02</td> <td>Control board thermistor 2 over temperature</td> </tr> <tr> <td>Control system</td> <td>00</td> <td>0</td> <td>03</td> <td>I/O board thermistor over temperature</td> </tr> </tbody> </table>	Source	xx	y	zz	Description	Control system	00	0	01	Control board thermistor 1 over temperature	Control system	00	0	02	Control board thermistor 2 over temperature	Control system	00	0	03	I/O board thermistor over temperature
	Source	xx	y	zz	Description																
	Control system	00	0	01	Control board thermistor 1 over temperature																
	Control system	00	0	02	Control board thermistor 2 over temperature																
Control system	00	0	03	I/O board thermistor over temperature																	
Recommended actions:																					
<ul style="list-style-type: none"> • Check enclosure / drive fans are still functioning correctly • Check enclosure ventilation paths • Check enclosure door filters • Increase ventilation • Reduce the drive switching frequency • Check ambient temperature 																					

Trip	Diagnosis																				
Oht dc bus	DC bus over temperature																				
27	<p>The <i>Oht dc bus</i> trip indicates a DC bus component over temperature based on a software thermal model. The drive includes a thermal protection system to protect the DC bus components within the drive. This includes the effects of the output current and DC bus ripple. The estimated temperature is displayed as a percentage of the trip level in Pr 07.035. If this parameter reaches 100 % then an <i>Oht dc bus</i> trip with sub-trip 200 is initiated. The drive will attempt to stop the motor before tripping. If the motor does not stop in 10 seconds the drive trips immediately.</p> <table border="1"> <thead> <tr> <th>Source</th> <th>xx</th> <th>y</th> <th>zz</th> <th>Description</th> </tr> </thead> <tbody> <tr> <td>Control system</td> <td>00</td> <td>2</td> <td>00</td> <td>DC bus thermal model gives trip with sub-trip 0</td> </tr> </tbody> </table> <p>It is also possible in a multi-power module system for DC bus over-temperature to be detected from within the power stage. From this source the estimated temperature as a percentage of trip is not available and the trip is indicated as follows:</p> <table border="1"> <thead> <tr> <th>Source</th> <th>xx</th> <th>y</th> <th>zz</th> <th>Description</th> </tr> </thead> <tbody> <tr> <td>Control system</td> <td>01</td> <td>0</td> <td>00</td> <td>Power stage gives trip with sub-trip 0</td> </tr> </tbody> </table> <p>Recommended actions:</p> <ul style="list-style-type: none"> • Check the AC supply voltage balance and levels • Check DC bus ripple level • Reduce duty cycle • Reduce motor load • Check the output current stability. If unstable; <ul style="list-style-type: none"> Check the motor map settings with motor nameplate (Pr 05.006, Pr 05.007, Pr 05.008, Pr 05.009, Pr 05.010, Pr 05.011) – (All Modes) Disable slip compensation (Pr 05.027 = 0) – (Open loop) Disable dynamic V to F operation (Pr 05.013 = 0) - (Open loop) Select fixed boost (Pr 05.014 = Fixed) – (Open loop) Select high stability space vector modulation (Pr 05.020 = 1) – (Open loop) Disconnect the load and complete a rotating auto-tune (Pr 05.012) – (RFC-A, RFC-S) Auto-tune the rated speed value (Pr 05.016 = 1) – (RFC-A, RFC-S) Reduce speed loop gains (Pr 03.010, Pr 03.011, Pr 03.012) – (RFC-A, RFC-S) Add a speed feedback filter value (Pr 03.042) – (RFC-A, RFC-S) Add a current demand filter (Pr 04.012) – (RFC-A, RFC-S) Check encoder signals for noise with an oscilloscope (RFC-A, RFC-S) Check encoder mechanical coupling - (RFC-A, RFC-S) 	Source	xx	y	zz	Description	Control system	00	2	00	DC bus thermal model gives trip with sub-trip 0	Source	xx	y	zz	Description	Control system	01	0	00	Power stage gives trip with sub-trip 0
	Source	xx	y	zz	Description																
	Control system	00	2	00	DC bus thermal model gives trip with sub-trip 0																
	Source	xx	y	zz	Description																
Control system	01	0	00	Power stage gives trip with sub-trip 0																	
Oht Inverter	Inverter over temperature based on thermal model																				
21	<p>This trip indicates that an IGBT junction over-temperature has been detected based on a software thermal model. The sub-trip indicates which model has initiated the trip in the form xxyzz as given below:</p> <table border="1"> <thead> <tr> <th>Source</th> <th>xx</th> <th>y</th> <th>zz</th> <th>Description</th> </tr> </thead> <tbody> <tr> <td>Control system</td> <td>00</td> <td>1</td> <td>00</td> <td>Inverter thermal model</td> </tr> <tr> <td>Control system</td> <td>00</td> <td>3</td> <td>00</td> <td>Braking IGBT thermal model</td> </tr> </tbody> </table> <p>Recommended actions with sub-trip 100:</p> <ul style="list-style-type: none"> • Reduce the selected drive switching frequency • Ensure <i>Auto-switching Frequency Change Disable</i> (05.035) is set to Off • Reduce duty cycle • Increase acceleration / deceleration rates • Reduce motor load • Check DC bus ripple • Ensure all three input phases are present and balanced <p>Recommended actions with sub-trip 300:</p> <ul style="list-style-type: none"> • Reduce the braking load 	Source	xx	y	zz	Description	Control system	00	1	00	Inverter thermal model	Control system	00	3	00	Braking IGBT thermal model					
	Source	xx	y	zz	Description																
	Control system	00	1	00	Inverter thermal model																
	Control system	00	3	00	Braking IGBT thermal model																

Trip	Diagnosis																																																		
Oht Power	Power stage over temperature																																																		
22	<p>This trip indicates that a power stage over-temperature has been detected. From the sub-trip 'xyzz', the Thermistor location which is indicating the over-temperature is identified by 'zz'. The thermistor numbering is different for a single module type drive (i.e. no parallel board fitted) and a multi-module type drive (i.e. parallel board fitted with one or more power modules) as shown below:</p> <p>Single module type drive:</p> <table border="1"> <thead> <tr> <th>Source</th> <th>xx</th> <th>y</th> <th>zz</th> <th>Description</th> </tr> </thead> <tbody> <tr> <td>Power system</td> <td>01</td> <td>0</td> <td>zz</td> <td>Thermistor location defined by zz in the power board</td> </tr> <tr> <td>Power system</td> <td>01</td> <td>Rectifier number</td> <td>zz</td> <td>Thermistor location defined by zz in the rectifier</td> </tr> </tbody> </table> <p>Multi-module type system:</p> <table border="1"> <thead> <tr> <th>Source</th> <th>xx</th> <th>y</th> <th>zz</th> <th>Description</th> </tr> </thead> <tbody> <tr> <td>Power system</td> <td>power module number</td> <td>0</td> <td>01</td> <td>U phase power device</td> </tr> <tr> <td>Power system</td> <td>power module number</td> <td>0</td> <td>02</td> <td>V phase power device</td> </tr> <tr> <td>Power system</td> <td>power module number</td> <td>0</td> <td>03</td> <td>W phase power device</td> </tr> <tr> <td>Power system</td> <td>power module number</td> <td>0</td> <td>04</td> <td>Rectifier</td> </tr> <tr> <td>Power system</td> <td>power module number</td> <td>0</td> <td>05</td> <td>General power system</td> </tr> <tr> <td>Power system</td> <td>power module number</td> <td>0</td> <td>00</td> <td>Braking IGBT</td> </tr> </tbody> </table> <p>Note that the power module that has caused the trip cannot be identified except for the braking IGBT temperature measurement</p> <p>Recommended actions:</p> <ul style="list-style-type: none"> • Check enclosure / drive fans are still functioning correctly • Force the heatsink fans to run at maximum speed • Check enclosure ventilation paths • Check enclosure door filters • Increase ventilation • Reduce the drive switching frequency • Reduce duty cycle • Increase acceleration / deceleration rates • Use S ramp (Pr 02.006) • Reduce motor load • Check the derating tables and confirm the drive is correctly sized for the application. • Use a drive with larger current / power rating 	Source	xx	y	zz	Description	Power system	01	0	zz	Thermistor location defined by zz in the power board	Power system	01	Rectifier number	zz	Thermistor location defined by zz in the rectifier	Source	xx	y	zz	Description	Power system	power module number	0	01	U phase power device	Power system	power module number	0	02	V phase power device	Power system	power module number	0	03	W phase power device	Power system	power module number	0	04	Rectifier	Power system	power module number	0	05	General power system	Power system	power module number	0	00	Braking IGBT
	Source	xx	y	zz	Description																																														
	Power system	01	0	zz	Thermistor location defined by zz in the power board																																														
	Power system	01	Rectifier number	zz	Thermistor location defined by zz in the rectifier																																														
	Source	xx	y	zz	Description																																														
	Power system	power module number	0	01	U phase power device																																														
	Power system	power module number	0	02	V phase power device																																														
	Power system	power module number	0	03	W phase power device																																														
	Power system	power module number	0	04	Rectifier																																														
	Power system	power module number	0	05	General power system																																														
Power system	power module number	0	00	Braking IGBT																																															
OI ac	Instantaneous output over current detected																																																		
3	<p>The instantaneous drive output current has exceeded VM_DRIVE_CURRENT[MAX]. This trip cannot be reset until 10 s after the trip was initiated.</p> <table border="1"> <thead> <tr> <th>Source</th> <th>xx</th> <th>y</th> <th>zz</th> <th>Description</th> </tr> </thead> <tbody> <tr> <td>Control system</td> <td>00</td> <td>0</td> <td rowspan="2">00</td> <td rowspan="2">Instantaneous over-current trip when the measured AC current exceeds VM_DRIVE_CURRENT[MAX].</td> </tr> <tr> <td>Power system</td> <td>Power module number</td> <td>0</td> </tr> </tbody> </table> <p>Recommended actions:</p> <ul style="list-style-type: none"> • Acceleration/deceleration rate is too short • If seen during auto-tune reduce the voltage boost • Check for short circuit on the output cabling • Check integrity of the motor insulation using an insulation tester • Check feedback device wiring • Check feedback device mechanical coupling • Check feedback signals are free from noise • Is motor cable length within limits for the frame size • Reduce the values in the speed loop gain parameters - (Pr 03.010, 03.011, 03.012) or (Pr 03.013, 03.014, 03.015) • Has the phase angle autotune been completed? (RFC-S mode only) • Reduce the values in current loop gain parameters (RFC-A, RFC-S modes only) 	Source	xx	y	zz	Description	Control system	00	0	00	Instantaneous over-current trip when the measured AC current exceeds VM_DRIVE_CURRENT[MAX].	Power system	Power module number	0																																					
	Source	xx	y	zz	Description																																														
	Control system	00	0	00	Instantaneous over-current trip when the measured AC current exceeds VM_DRIVE_CURRENT[MAX].																																														
Power system	Power module number	0																																																	

Trip	Diagnosis												
OI Brake	Braking IGBT over current detected: short circuit protection for the braking IGBT activated												
4	The <i>OI Brake</i> trip indicates that over current has been detected in braking IGBT or braking IGBT protection has been activated. This trip cannot be reset until 10 s after the trip was initiated.												
	<table border="1"> <thead> <tr> <th>Source</th> <th>xx</th> <th>y</th> <th>zz</th> <th>Description</th> </tr> </thead> <tbody> <tr> <td>Power system</td> <td>Power module number</td> <td>0</td> <td>00</td> <td>Braking IGBT instantaneous over-current trip</td> </tr> </tbody> </table>	Source	xx	y	zz	Description	Power system	Power module number	0	00	Braking IGBT instantaneous over-current trip		
	Source	xx	y	zz	Description								
Power system	Power module number	0	00	Braking IGBT instantaneous over-current trip									
<p>Recommended actions:</p> <ul style="list-style-type: none"> • Check brake resistor wiring • Check braking resistor value is greater than or equal to the minimum resistance value • Check braking resistor insulation 													
OI dc	Power module over current detected from IGBT on state voltage monitoring												
109	The <i>OI dc</i> trip indicates that the short circuit protection for the drive output stage has been activated. The table below shows where the trip has been detected. This trip cannot be reset until 10 s after the trip was initiated.												
	<table border="1"> <thead> <tr> <th>Source</th> <th>xx</th> <th>y</th> <th>zz</th> </tr> </thead> <tbody> <tr> <td>Control system</td> <td>00</td> <td>0</td> <td>00</td> </tr> <tr> <td>Power system</td> <td>Power module number</td> <td>0</td> <td>00</td> </tr> </tbody> </table>	Source	xx	y	zz	Control system	00	0	00	Power system	Power module number	0	00
	Source	xx	y	zz									
Control system	00	0	00										
Power system	Power module number	0	00										
<p>Recommended actions:</p> <ul style="list-style-type: none"> • Disconnect the motor cable at the drive end and check the motor and cable insulation with an insulation tester • Replace the drive 													
Option Disable	Option module does not acknowledge during drive mode changeover												
215	The <i>Option Disable</i> trip indicates that the option module did not acknowledge to the drive that communications with the drive has been stopped during the drive mode changeover with in the allocated time.												
	<p>Recommended trip:</p> <ul style="list-style-type: none"> • Reset the trip • If the trip persists, replace the option module 												
Out Phase Loss	Output phase loss detected												
98	The <i>Out Phase Loss</i> trip indicates that phase loss has been detected at the drive output.												
	<table border="1"> <thead> <tr> <th>Sub-trip</th> <th>Reason</th> </tr> </thead> <tbody> <tr> <td>1</td> <td>U phase detected as disconnected when drive enabled to run.</td> </tr> <tr> <td>2</td> <td>V phase detected as disconnected when drive enabled to run.</td> </tr> <tr> <td>3</td> <td>W phase detected as disconnected when drive enabled to run.</td> </tr> <tr> <td>4</td> <td>Output phase loss detected when the drive is running.</td> </tr> </tbody> </table>	Sub-trip	Reason	1	U phase detected as disconnected when drive enabled to run.	2	V phase detected as disconnected when drive enabled to run.	3	W phase detected as disconnected when drive enabled to run.	4	Output phase loss detected when the drive is running.		
	Sub-trip	Reason											
1	U phase detected as disconnected when drive enabled to run.												
2	V phase detected as disconnected when drive enabled to run.												
3	W phase detected as disconnected when drive enabled to run.												
4	Output phase loss detected when the drive is running.												
<p>NOTE</p> <p>If Pr 05.042 = 1 the physical output phases are reversed, and so sub-trip 3 refers to physical output phase V and sub-trip 2 refers to physical output phase W.</p> <p>Recommended actions:</p> <ul style="list-style-type: none"> • Check motor and drive connections • To disable the trip set <i>Output Phase Loss Detection Enable</i> (06.059) = 0 													
Over Speed	Motor speed has exceeded the over speed threshold												
7	In open loop mode, if the <i>Output Frequency</i> (05.001) exceeds the threshold set in <i>Over Speed Threshold</i> (03.008) in either direction an <i>Over Speed</i> trip is produced. In RFC-A and RFC-S mode, if the Speed Feedback (03.002) exceeds the <i>Over Speed Threshold</i> in Pr 03.008 in either direction an <i>Over Speed</i> trip is produced. If Pr 03.008 is set to 0.0 the threshold is then equal to 1.2 x the value set in Pr 01.006 .												
	<p>In RFC-A and RFC-S mode, if an SSI encoder is being used and Pr 03.047 is set to 0 an <i>Over Speed</i> trip will be produced when the encoder passes through the boundary between its maximum position and zero.</p> <p>Recommended actions:</p> <ul style="list-style-type: none"> • Check the motor is not being driven by another part of the system • Reduce the <i>Speed Controller Proportional Gain</i> (03.010) to reduce the speed overshoot (RFC-A, RFC-S modes only) • If an SSI encoder is being used set Pr 03.047 to 1 <p>The above description relates to a standard Over Speed trip, however in RFC-S mode it is possible to produce an <i>Over Speed.1</i> trip. This is caused if the speed is allowed to exceed the safe level in RFC-S mode with flux weakening when <i>Enable High Speed Mode</i> (05.022) is set to -1.</p>												

Trip	Diagnosis																											
Over Volts	DC bus voltage has exceeded the peak level or maximum continuous level for 15 seconds																											
2	<p>The <i>Over Volts</i> trip indicates that the DC bus voltage has exceeded the VM_DC_VOLTAGE[MAX] or VM_DC_VOLTAGE_SET[MAX] for 15 s. The trip threshold varies depending on voltage rating of the drive as shown below.</p> <table border="1"> <thead> <tr> <th>Voltage rating</th> <th>VM_DC_VOLTAGE[MAX]</th> <th>VM_DC_VOLTAGE_SET[MAX]</th> </tr> </thead> <tbody> <tr> <td>200</td> <td>415</td> <td>410</td> </tr> <tr> <td>400</td> <td>830</td> <td>815</td> </tr> <tr> <td>575</td> <td>990</td> <td>970</td> </tr> <tr> <td>690</td> <td>1190</td> <td>1175</td> </tr> </tbody> </table> <p>Sub-trip Identification</p> <table border="1"> <thead> <tr> <th>Source</th> <th>xx</th> <th>y</th> <th>zz</th> </tr> </thead> <tbody> <tr> <td>Control system</td> <td>00</td> <td>0</td> <td>01: Instantaneous trip when the DC bus voltage exceeds VM_DC_VOLTAGE[MAX].</td> </tr> <tr> <td>Control system</td> <td>00</td> <td>0</td> <td>02: Time delayed trip indicating that the DC bus voltage is above VM_DC_VOLTAGE_SET[MAX].</td> </tr> </tbody> </table> <p>Recommended actions:</p> <ul style="list-style-type: none"> • Increase deceleration ramp (Pr 00.004) • Decrease the braking resistor value (staying above the minimum value) • Check nominal AC supply level • Check for supply disturbances which could cause the DC bus to rise • Check motor insulation using an insulation tester 	Voltage rating	VM_DC_VOLTAGE[MAX]	VM_DC_VOLTAGE_SET[MAX]	200	415	410	400	830	815	575	990	970	690	1190	1175	Source	xx	y	zz	Control system	00	0	01: Instantaneous trip when the DC bus voltage exceeds VM_DC_VOLTAGE[MAX].	Control system	00	0	02: Time delayed trip indicating that the DC bus voltage is above VM_DC_VOLTAGE_SET[MAX].
	Voltage rating	VM_DC_VOLTAGE[MAX]	VM_DC_VOLTAGE_SET[MAX]																									
200	415	410																										
400	830	815																										
575	990	970																										
690	1190	1175																										
Source	xx	y	zz																									
Control system	00	0	01: Instantaneous trip when the DC bus voltage exceeds VM_DC_VOLTAGE[MAX].																									
Control system	00	0	02: Time delayed trip indicating that the DC bus voltage is above VM_DC_VOLTAGE_SET[MAX].																									
Phase Loss	Supply phase loss																											
32	<p>The Phase Loss trip indicates that the drive has detected an input phase loss or large supply imbalance. Phase loss can be detected directly from the supply where the drive has a thyristor base charge system (Frame size 8 and above). If phase loss is detected using this method the drive trips immediately and the xx part of the sub-trip is set to 01. In all sizes of drive phase loss is also detected by monitoring the ripple in the DC bus voltage in which case the drive attempts to stop the drive before tripping unless bit 2 of <i>Action On Trip Detection</i> (10.037) is set to one. When phase loss is detected by monitoring the ripple in the DC bus voltage the xx part of the sub-trip is zero.</p> <table border="1"> <thead> <tr> <th>Source</th> <th>xx</th> <th>y</th> <th>zz</th> </tr> </thead> <tbody> <tr> <td>Control system</td> <td>00</td> <td>0</td> <td>00: Phase loss detected from DC bus ripple</td> </tr> <tr> <td>Power system (1)</td> <td>Power module number</td> <td>Rectifier number (2)</td> <td>00: Phase loss detected directly from the supply</td> </tr> </tbody> </table> <p>(1) Input phase loss detection can be disabled when the drive required to operate from the DC supply or from a single phase supply in <i>Input Phase Loss Detection Mode</i> (06.047).</p> <p>(2) For a parallel power-module system the rectifier number will be one as it is not possible to determine which rectifier has detected the fault.</p> <p>This trip does not occur in regen mode.</p> <p>Recommended actions:</p> <ul style="list-style-type: none"> • Check the AC supply voltage balance and level at full load • Check the DC bus ripple level with an isolated oscilloscope • Check the output current stability • Check for mechanical resonance with the load • Reduce the duty cycle • Reduce the motor load • Disable the phase loss detection, set Pr 06.047 to 2. 	Source	xx	y	zz	Control system	00	0	00: Phase loss detected from DC bus ripple	Power system (1)	Power module number	Rectifier number (2)	00: Phase loss detected directly from the supply															
Source	xx	y	zz																									
Control system	00	0	00: Phase loss detected from DC bus ripple																									
Power system (1)	Power module number	Rectifier number (2)	00: Phase loss detected directly from the supply																									
Phasing Error	RFC-S mode phasing failure due to incorrect phase angle																											
198	<p>The <i>Phasing Error</i> trip indicates that the phase offset angle in Pr 03.025 (or Pr 21.020 if the second motor map is being used) is incorrect if position feedback is being used and the drive is unable to control the motor correctly.</p> <p>Recommended actions:</p> <ul style="list-style-type: none"> • Check the encoder wiring • Check the encoder signals for noise with an oscilloscope • Check the encoder mechanical coupling • Perform an auto-tune to measure the encoder phase angle or manually enter the correct phase angle into Pr 03.025 • Spurious <i>Phasing Error</i> trips can sometimes be seen in very dynamic applications. This trip can be disabled by setting the over-speed threshold in Pr 03.008 to a value greater than zero. <p>If sensorless control is being used this indicates that significant instability has occurred and the motor has accelerated without control.</p> <p>Recommended actions:</p> <ul style="list-style-type: none"> • Ensure that the motor parameters are set-up correctly. • Reduce the speed controller gains. 																											

Trip	Diagnosis																																																		
Power Comms	Communication has been lost / errors detected between power, control and rectifier modules																																																		
90	A <i>Power Comms</i> trip indicates a communications problem within the power system of the drive. The reason for the trip can be identified by the sub-trip number.																																																		
	<table border="1"> <thead> <tr> <th>Type of drive</th> <th>xx</th> <th>y</th> <th>zz</th> </tr> </thead> <tbody> <tr> <td>Single power module system</td> <td>01</td> <td>Rectifier number*</td> <td>00: Excessive communications errors detected by the rectifier module.</td> </tr> </tbody> </table>	Type of drive	xx	y	zz	Single power module system	01	Rectifier number*	00: Excessive communications errors detected by the rectifier module.																																										
	Type of drive	xx	y	zz																																															
Single power module system	01	Rectifier number*	00: Excessive communications errors detected by the rectifier module.																																																
<p>* For a parallel power-module system the rectifier number will be one as it is not possible to determine which rectifier has detected the fault.</p> <p>Recommended actions:</p> <ul style="list-style-type: none"> Hardware fault – Contact the supplier of the drive 																																																			
Power Data	Power system configuration data error																																																		
220	The <i>Power Data</i> trip indicates that there is an error in the configuration data stored in the power system.																																																		
	<table border="1"> <thead> <tr> <th>Source</th> <th>xx</th> <th>y</th> <th>zz</th> <th>Description</th> </tr> </thead> <tbody> <tr> <td>Control system</td> <td>00</td> <td>0</td> <td>02</td> <td>There is no data table to be uploaded to the control board</td> </tr> <tr> <td>Control system</td> <td>00</td> <td>0</td> <td>03</td> <td>The power system data table is bigger than the space available in the control pod to store it.</td> </tr> <tr> <td>Control system</td> <td>00</td> <td>0</td> <td>04</td> <td>The size of the table given in the table is incorrect.</td> </tr> <tr> <td>Control system</td> <td>00</td> <td>0</td> <td>05</td> <td>Table CRC error.</td> </tr> <tr> <td>Control system</td> <td>00</td> <td>0</td> <td>06</td> <td>The version number of the generator software that produced the table is too low. i.e. a table from a newer generator is required that includes features that have been added to the table that may not be present.</td> </tr> <tr> <td>Control system</td> <td>00</td> <td>0</td> <td>07</td> <td>The power board data table does not match the power board hardware identifier.</td> </tr> <tr> <td>Power system</td> <td>01</td> <td>0</td> <td>00</td> <td>The power data table used internally by the power module has an error. (For a multi-power module drive this indicates any error with the code tables in the power system).</td> </tr> <tr> <td>Power system</td> <td>01</td> <td>0</td> <td>01</td> <td>The power data table that should be uploaded to the control system on power up has an error.</td> </tr> <tr> <td>Power system</td> <td>01</td> <td>0</td> <td>02</td> <td>The power data table used internally by the power module does not match the hardware identification of the power module.</td> </tr> </tbody> </table>	Source	xx	y	zz	Description	Control system	00	0	02	There is no data table to be uploaded to the control board	Control system	00	0	03	The power system data table is bigger than the space available in the control pod to store it.	Control system	00	0	04	The size of the table given in the table is incorrect.	Control system	00	0	05	Table CRC error.	Control system	00	0	06	The version number of the generator software that produced the table is too low. i.e. a table from a newer generator is required that includes features that have been added to the table that may not be present.	Control system	00	0	07	The power board data table does not match the power board hardware identifier.	Power system	01	0	00	The power data table used internally by the power module has an error. (For a multi-power module drive this indicates any error with the code tables in the power system).	Power system	01	0	01	The power data table that should be uploaded to the control system on power up has an error.	Power system	01	0	02	The power data table used internally by the power module does not match the hardware identification of the power module.
	Source	xx	y	zz	Description																																														
	Control system	00	0	02	There is no data table to be uploaded to the control board																																														
	Control system	00	0	03	The power system data table is bigger than the space available in the control pod to store it.																																														
	Control system	00	0	04	The size of the table given in the table is incorrect.																																														
	Control system	00	0	05	Table CRC error.																																														
	Control system	00	0	06	The version number of the generator software that produced the table is too low. i.e. a table from a newer generator is required that includes features that have been added to the table that may not be present.																																														
	Control system	00	0	07	The power board data table does not match the power board hardware identifier.																																														
	Power system	01	0	00	The power data table used internally by the power module has an error. (For a multi-power module drive this indicates any error with the code tables in the power system).																																														
Power system	01	0	01	The power data table that should be uploaded to the control system on power up has an error.																																															
Power system	01	0	02	The power data table used internally by the power module does not match the hardware identification of the power module.																																															
<p>Recommended actions:</p> <ul style="list-style-type: none"> Hardware fault – Contact the supplier of the drive 																																																			
Power Down Save	Power down save error																																																		
37	<p>The <i>Power Down Save</i> trip indicates that an error has been detected in the power down save parameters saved in non-volatile memory.</p> <p>Recommended actions:</p> <ul style="list-style-type: none"> Perform a 1001 save in Pr mm.000 to ensure that the trip doesn't occur the next time the drive is powered up. 																																																		
PSU	Internal power supply fault																																																		
5	The <i>PSU</i> trip indicates that one or more internal power supply rails are outside limits or overloaded.																																																		
	<table border="1"> <thead> <tr> <th>Source</th> <th>xx</th> <th>y</th> <th>zz</th> <th>Description</th> </tr> </thead> <tbody> <tr> <td>Control system</td> <td>00</td> <td>0</td> <td rowspan="2">00</td> <td>Internal power supply overload</td> </tr> <tr> <td>Power system</td> <td>Power module number</td> <td>Rectifier number*</td> <td>Rectifier internal power supply overload</td> </tr> </tbody> </table>	Source	xx	y	zz	Description	Control system	00	0	00	Internal power supply overload	Power system	Power module number	Rectifier number*	Rectifier internal power supply overload																																				
	Source	xx	y	zz	Description																																														
Control system	00	0	00	Internal power supply overload																																															
Power system	Power module number	Rectifier number*		Rectifier internal power supply overload																																															
<p>* For a parallel power-module system the rectifier number will be zero as it is not possible to determine which rectifier has detected the fault.</p> <p>Recommended actions:</p> <ul style="list-style-type: none"> Remove any option modules and perform a reset Remove encoder connection and perform a reset Hardware fault within the drive – return the drive to the supplier 																																																			

Trip	Diagnosis														
PSU 24V	24V internal power supply overload														
9	<p>The total user load of the drive and option modules has exceeded the internal 24 V power supply limit. The user load consists of the drive digital outputs and main encoder supply.</p> <p>Recommended actions:</p> <ul style="list-style-type: none"> Reduce the load and reset Provide an external 24 V power supply on control terminal 2 Remove all option modules 														
Rating Mismatch	Power stage recognition: Multi module voltage or current rating mismatch														
223	<p>The <i>Rating Mismatch</i> trip indicates that there is a voltage rating or current rating mismatch in a multi-module drive system. This trip is only applicable to modular drives that are connected in parallel. A mixture of power modules with different voltage or current ratings within the same multi-module drive system is not allowed and will cause a <i>Rating Mismatch</i> trip.</p> <p>Recommended action:</p> <ul style="list-style-type: none"> Ensure that all modules in a multi-modular drive system are of the same frame size and rating (voltage and current) Hardware fault – Contact the supplier of the drive 														
Rectifier Set-up	A rectifier has not been set-up correctly in a multi-power module system														
94	<p>A rectifier has not been set-up correctly in a multi-power module system</p> <p>Recommended action:</p> <ul style="list-style-type: none"> Check the inter-power module wiring 														
Reserved	Reserved trips														
01 95 104 – 108 165 – 168 170 – 173 222, 228 - 246	<p>These trip numbers are reserved trip numbers for future use. These trips should not be used by the user application programs.</p> <table border="1"> <thead> <tr> <th>Trip Number</th> <th>Description</th> </tr> </thead> <tbody> <tr> <td>01</td> <td>Reserved resettable trip</td> </tr> <tr> <td>95</td> <td>Reserved resettable trip</td> </tr> <tr> <td>104 - 108</td> <td>Reserved resettable trip</td> </tr> <tr> <td>165 - 168</td> <td>Reserved resettable trip</td> </tr> <tr> <td>170 - 173</td> <td>Reserved resettable trip</td> </tr> <tr> <td>222, 228 - 246</td> <td>Reserved non-resettable trip</td> </tr> </tbody> </table>	Trip Number	Description	01	Reserved resettable trip	95	Reserved resettable trip	104 - 108	Reserved resettable trip	165 - 168	Reserved resettable trip	170 - 173	Reserved resettable trip	222, 228 - 246	Reserved non-resettable trip
Trip Number	Description														
01	Reserved resettable trip														
95	Reserved resettable trip														
104 - 108	Reserved resettable trip														
165 - 168	Reserved resettable trip														
170 - 173	Reserved resettable trip														
222, 228 - 246	Reserved non-resettable trip														
Resistance	Measured resistance has exceeded the parameter range														
33	<p>This trip indicates that either the value being used for motor stator resistance is too high or that an attempt to do a test involving measuring motor stator resistance has failed. The maximum for the stator resistance parameters is generally higher than the maximum value that can be used in the control algorithms. If the value exceeds $(V_{FS} / \sqrt{2}) / Full\ Scale\ Current\ Kc$ (11.061), where V_{FS} is the full scale DC bus voltage then this trip is initiated. If the value is the result of a measurement made by the drive then sub-trip 1 is applied, or if it is because the parameter has been changed by the user then sub-trip 3 is applied. During the stator resistance section of auto-tuning an additional test is performed to measured the drive inverter characteristics to provide the compensation necessary for dead-times. If the inverter characteristic measurement fails then sub-trip 2 is applied.</p> <table border="1"> <thead> <tr> <th>Sub-trip</th> <th>Reason</th> </tr> </thead> <tbody> <tr> <td>1</td> <td>Measured stator resistance exceeded the allowed range</td> </tr> <tr> <td>2</td> <td>It was not possible to measure the inverter characteristic</td> </tr> <tr> <td>3</td> <td>The stator resistance associated with the presently selected motor map exceeds the allowed range</td> </tr> </tbody> </table> <p>Recommended actions:</p> <ul style="list-style-type: none"> Check that the value that has been entered in the stator resistance does not exceed the allowed range (for the presently selected motor map) Check the motor cable / connections Check the integrity of the motor stator winding using a insulation tester Check the motor phase to phase resistance at the drive terminals Check the motor phase to phase resistance at the motor terminals Ensure the stator resistance of the motor falls within the range of the drive model Select fixed boost mode (Pr 05.014 = Fixed) and verify the output current waveforms with an oscilloscope Replace the motor 	Sub-trip	Reason	1	Measured stator resistance exceeded the allowed range	2	It was not possible to measure the inverter characteristic	3	The stator resistance associated with the presently selected motor map exceeds the allowed range						
Sub-trip	Reason														
1	Measured stator resistance exceeded the allowed range														
2	It was not possible to measure the inverter characteristic														
3	The stator resistance associated with the presently selected motor map exceeds the allowed range														

Trip	Diagnosis												
Slot4 Different	<p>Ethernet interface in slot 4 has changed (<i>Unidrive M700 / M702</i>)</p> <p>The <i>Slot4 Different</i> trip indicates that the Ethernet interface in slot 4 has changed / not found. The reason for the trip can be identified by the sub-trip number.</p> <table border="1"> <thead> <tr> <th style="text-align: center;">Sub-trip</th> <th style="text-align: center;">Reason</th> </tr> </thead> <tbody> <tr> <td style="text-align: center;">1</td> <td>No module was installed previously</td> </tr> <tr> <td style="text-align: center;">2</td> <td>A module with the same identifier is installed, but the set-up menu for this option slot has been changed, and so default parameters have been loaded for this menu.</td> </tr> <tr> <td style="text-align: center;">3</td> <td>A module with the same identifier is installed, but the applications menu for this option slot has been changed, and so default parameters have been loaded for this menu.</td> </tr> <tr> <td style="text-align: center;">4</td> <td>A module with the same identifier is installed, but the set-up and applications menu for this option slot have been changed, and so default parameters have been loaded for these menus.</td> </tr> <tr> <td style="text-align: center;">>99</td> <td>Shows the identifier of the module previously installed.</td> </tr> </tbody> </table> <p>Recommended actions:</p> <ul style="list-style-type: none"> • Turn off the power, ensure that the correct option module is installed in the option slot and re-apply the power. • Confirm that the currently installed option module is correct, ensure the option module parameters are set correctly and perform a <i>User Save</i> in Pr mm.000. • If the trip persists - Contact the supplier of the drive. 	Sub-trip	Reason	1	No module was installed previously	2	A module with the same identifier is installed, but the set-up menu for this option slot has been changed, and so default parameters have been loaded for this menu.	3	A module with the same identifier is installed, but the applications menu for this option slot has been changed, and so default parameters have been loaded for this menu.	4	A module with the same identifier is installed, but the set-up and applications menu for this option slot have been changed, and so default parameters have been loaded for these menus.	>99	Shows the identifier of the module previously installed.
Sub-trip	Reason												
1	No module was installed previously												
2	A module with the same identifier is installed, but the set-up menu for this option slot has been changed, and so default parameters have been loaded for this menu.												
3	A module with the same identifier is installed, but the applications menu for this option slot has been changed, and so default parameters have been loaded for this menu.												
4	A module with the same identifier is installed, but the set-up and applications menu for this option slot have been changed, and so default parameters have been loaded for these menus.												
>99	Shows the identifier of the module previously installed.												
254													

Trip	Diagnosis																																																																																																																																											
Slot4 Error	Ethernet interface in slot 4 has detected a fault (<i>Unidrive M700 / M702</i>)																																																																																																																																											
	The <i>Slot4 Error</i> trip indicates that the Ethernet interface in slot 4 on the drive has detected an error. The reason for the trip can be identified by the sub-trip number.																																																																																																																																											
252	<table border="1"> <thead> <tr> <th style="text-align: center;">Sub-trip</th> <th style="text-align: center;">Trip string</th> <th style="text-align: center;">Description</th> </tr> </thead> <tbody> <tr><td>100</td><td>Link Loss</td><td>Network link has been lost</td></tr> <tr><td>101</td><td>E/IP Timeout</td><td>An EtherNet/IP RPI timeout trip has occurred</td></tr> <tr><td>102</td><td>E/IP Read Param</td><td>Invalid read consistency parameter</td></tr> <tr><td>103</td><td>E/IP Write Param</td><td>Invalid write consistency parameter</td></tr> <tr><td>104</td><td>E/IP Fault</td><td>An unexpected EtherNet/IP error has occurred</td></tr> <tr><td>105</td><td>Modbus Timeout</td><td>The Modbus connection has timed out</td></tr> <tr><td>106</td><td>DA-RT Timeout</td><td>DA-RX Rx link has timeout</td></tr> <tr><td>107</td><td>DA-RT Rx Late</td><td>Rx data was received late</td></tr> <tr><td>108</td><td>INIT Switch</td><td>Ethernet switch initialisation error</td></tr> <tr><td>109</td><td>INIT PTP</td><td>IEEE1588 (Precision Time Protocol) initialisation error</td></tr> <tr><td>110</td><td>INIT DA-RT</td><td>Cyclic data initialisation error</td></tr> <tr><td>111</td><td>INIT Modbus</td><td>Modbus TCP initialisation error</td></tr> <tr><td>112</td><td>INIT SMTP</td><td>Email (SMTP) initialisation error</td></tr> <tr><td>113</td><td>INIT EtherNet/IP</td><td>Ethernet/IP initialisation error</td></tr> <tr><td>114</td><td>INIT TCP/IP</td><td>TCP/IP initialisation error</td></tr> <tr><td>115</td><td>Ethernet Failure</td><td>Ethernet controller initialisation error</td></tr> <tr><td>116</td><td>E/IP PLC IDLE</td><td>Ethernet/IP PLC Idle</td></tr> <tr><td>117</td><td>Sync Task ORun</td><td>Synchronous task overrun</td></tr> <tr><td>118</td><td>INIT Param Chann</td><td>Parameter channel initialization error</td></tr> <tr><td>119</td><td>Link Overload</td><td>Too many links to be handled in the same cycle</td></tr> <tr><td>120</td><td>Mcast Over Limit</td><td>Too many multicast addresses being used</td></tr> <tr><td>121</td><td>Init Profinet</td><td>Profinet initialisation error</td></tr> <tr><td>122</td><td>Profinet Start</td><td>Profinet start error</td></tr> <tr><td>123</td><td>Profinet Plug</td><td>Profinet failed to load the slots</td></tr> <tr><td>124</td><td>Invalid IM</td><td>Invalid Identification and Maintenance data</td></tr> <tr><td>125</td><td>CPM Watchdog</td><td>Profinet cyclic timeout error</td></tr> <tr><td>200</td><td>Software Fault</td><td>Software Fault</td></tr> <tr><td>201</td><td>BG Overrun</td><td>Background task overrun</td></tr> <tr><td>202</td><td>Firmware Invalid</td><td>Firmware is not compatible for the hardware version</td></tr> <tr><td>203</td><td>Drive Unknown</td><td>Unknown drive type</td></tr> <tr><td>204</td><td>DriveUnsupported</td><td>Unsupported drive type</td></tr> <tr><td>205</td><td>Mode Unknown</td><td>Unknown drive mode</td></tr> <tr><td>206</td><td>Mode Unsupported</td><td>Unsupported drive mode</td></tr> <tr><td>207</td><td>FLASH Error</td><td>Corrupted Non-volatile FLASH</td></tr> <tr><td>208</td><td>Database Init</td><td>Database initialization error</td></tr> <tr><td>209</td><td>File System Init</td><td>File system initialization error</td></tr> <tr><td>210</td><td>Mem Allocation</td><td>Memory allocation error</td></tr> <tr><td>211</td><td>Filesystem Error</td><td>File system error</td></tr> <tr><td>212</td><td>Config Save</td><td>Configuration file save error</td></tr> <tr><td>213</td><td>Over Temperature</td><td>Option module over temperature</td></tr> <tr><td>214</td><td>Drive Timeout</td><td>The drive has not responded within watchdog period</td></tr> <tr><td>215</td><td>eCMP Comms Error</td><td>eCMP communication failure</td></tr> <tr><td>216</td><td>TO eCMP Slot1</td><td>eCMP communication to slot 1 timeout</td></tr> <tr><td>217</td><td>TO eCMP Slot2</td><td>eCMP communication to slot 2 timeout</td></tr> <tr><td>228</td><td>EEPROM Error</td><td>EEPROM Initialisation error</td></tr> </tbody> </table>	Sub-trip	Trip string	Description	100	Link Loss	Network link has been lost	101	E/IP Timeout	An EtherNet/IP RPI timeout trip has occurred	102	E/IP Read Param	Invalid read consistency parameter	103	E/IP Write Param	Invalid write consistency parameter	104	E/IP Fault	An unexpected EtherNet/IP error has occurred	105	Modbus Timeout	The Modbus connection has timed out	106	DA-RT Timeout	DA-RX Rx link has timeout	107	DA-RT Rx Late	Rx data was received late	108	INIT Switch	Ethernet switch initialisation error	109	INIT PTP	IEEE1588 (Precision Time Protocol) initialisation error	110	INIT DA-RT	Cyclic data initialisation error	111	INIT Modbus	Modbus TCP initialisation error	112	INIT SMTP	Email (SMTP) initialisation error	113	INIT EtherNet/IP	Ethernet/IP initialisation error	114	INIT TCP/IP	TCP/IP initialisation error	115	Ethernet Failure	Ethernet controller initialisation error	116	E/IP PLC IDLE	Ethernet/IP PLC Idle	117	Sync Task ORun	Synchronous task overrun	118	INIT Param Chann	Parameter channel initialization error	119	Link Overload	Too many links to be handled in the same cycle	120	Mcast Over Limit	Too many multicast addresses being used	121	Init Profinet	Profinet initialisation error	122	Profinet Start	Profinet start error	123	Profinet Plug	Profinet failed to load the slots	124	Invalid IM	Invalid Identification and Maintenance data	125	CPM Watchdog	Profinet cyclic timeout error	200	Software Fault	Software Fault	201	BG Overrun	Background task overrun	202	Firmware Invalid	Firmware is not compatible for the hardware version	203	Drive Unknown	Unknown drive type	204	DriveUnsupported	Unsupported drive type	205	Mode Unknown	Unknown drive mode	206	Mode Unsupported	Unsupported drive mode	207	FLASH Error	Corrupted Non-volatile FLASH	208	Database Init	Database initialization error	209	File System Init	File system initialization error	210	Mem Allocation	Memory allocation error	211	Filesystem Error	File system error	212	Config Save	Configuration file save error	213	Over Temperature	Option module over temperature	214	Drive Timeout	The drive has not responded within watchdog period	215	eCMP Comms Error	eCMP communication failure	216	TO eCMP Slot1	eCMP communication to slot 1 timeout	217	TO eCMP Slot2	eCMP communication to slot 2 timeout	228	EEPROM Error	EEPROM Initialisation error	
Sub-trip	Trip string	Description																																																																																																																																										
100	Link Loss	Network link has been lost																																																																																																																																										
101	E/IP Timeout	An EtherNet/IP RPI timeout trip has occurred																																																																																																																																										
102	E/IP Read Param	Invalid read consistency parameter																																																																																																																																										
103	E/IP Write Param	Invalid write consistency parameter																																																																																																																																										
104	E/IP Fault	An unexpected EtherNet/IP error has occurred																																																																																																																																										
105	Modbus Timeout	The Modbus connection has timed out																																																																																																																																										
106	DA-RT Timeout	DA-RX Rx link has timeout																																																																																																																																										
107	DA-RT Rx Late	Rx data was received late																																																																																																																																										
108	INIT Switch	Ethernet switch initialisation error																																																																																																																																										
109	INIT PTP	IEEE1588 (Precision Time Protocol) initialisation error																																																																																																																																										
110	INIT DA-RT	Cyclic data initialisation error																																																																																																																																										
111	INIT Modbus	Modbus TCP initialisation error																																																																																																																																										
112	INIT SMTP	Email (SMTP) initialisation error																																																																																																																																										
113	INIT EtherNet/IP	Ethernet/IP initialisation error																																																																																																																																										
114	INIT TCP/IP	TCP/IP initialisation error																																																																																																																																										
115	Ethernet Failure	Ethernet controller initialisation error																																																																																																																																										
116	E/IP PLC IDLE	Ethernet/IP PLC Idle																																																																																																																																										
117	Sync Task ORun	Synchronous task overrun																																																																																																																																										
118	INIT Param Chann	Parameter channel initialization error																																																																																																																																										
119	Link Overload	Too many links to be handled in the same cycle																																																																																																																																										
120	Mcast Over Limit	Too many multicast addresses being used																																																																																																																																										
121	Init Profinet	Profinet initialisation error																																																																																																																																										
122	Profinet Start	Profinet start error																																																																																																																																										
123	Profinet Plug	Profinet failed to load the slots																																																																																																																																										
124	Invalid IM	Invalid Identification and Maintenance data																																																																																																																																										
125	CPM Watchdog	Profinet cyclic timeout error																																																																																																																																										
200	Software Fault	Software Fault																																																																																																																																										
201	BG Overrun	Background task overrun																																																																																																																																										
202	Firmware Invalid	Firmware is not compatible for the hardware version																																																																																																																																										
203	Drive Unknown	Unknown drive type																																																																																																																																										
204	DriveUnsupported	Unsupported drive type																																																																																																																																										
205	Mode Unknown	Unknown drive mode																																																																																																																																										
206	Mode Unsupported	Unsupported drive mode																																																																																																																																										
207	FLASH Error	Corrupted Non-volatile FLASH																																																																																																																																										
208	Database Init	Database initialization error																																																																																																																																										
209	File System Init	File system initialization error																																																																																																																																										
210	Mem Allocation	Memory allocation error																																																																																																																																										
211	Filesystem Error	File system error																																																																																																																																										
212	Config Save	Configuration file save error																																																																																																																																										
213	Over Temperature	Option module over temperature																																																																																																																																										
214	Drive Timeout	The drive has not responded within watchdog period																																																																																																																																										
215	eCMP Comms Error	eCMP communication failure																																																																																																																																										
216	TO eCMP Slot1	eCMP communication to slot 1 timeout																																																																																																																																										
217	TO eCMP Slot2	eCMP communication to slot 2 timeout																																																																																																																																										
228	EEPROM Error	EEPROM Initialisation error																																																																																																																																										
	<p>Recommended actions:</p> <ul style="list-style-type: none"> Identify the reason for the trip from the trip string or from sub-trip number and resolve the error. Reset the trip, If the trip persists, Hardware fault - Contact the supplier of the drive. 																																																																																																																																											

Trip	Diagnosis																						
Slot4 HF	Ethernet interface in slot 4 hardware fault (Unidrive M700 / M702)																						
250	The <i>Slot4 HF</i> trip indicates that the Ethernet interface in slot 4 cannot operate. The reason for the error can be identified by the sub-trip number.																						
	<table border="1"> <thead> <tr> <th>Sub-trip</th> <th>Reason</th> </tr> </thead> <tbody> <tr> <td>1</td> <td>The module category cannot be identified</td> </tr> <tr> <td>2</td> <td>All the required customized menu table information has not been supplied or the tables supplied are corrupt</td> </tr> <tr> <td>3</td> <td>There is insufficient memory available to allocate the comms buffers for this module</td> </tr> <tr> <td>4</td> <td>The module has not indicated that it is running correctly during drive power-up</td> </tr> <tr> <td>5</td> <td>Module has been removed after power-up or it has stopped working</td> </tr> <tr> <td>6</td> <td>The module has not indicated that it has stopped accessing drive parameters during a drive mode change</td> </tr> <tr> <td>7</td> <td>The module has failed to acknowledge that a request has been made to reset the drive processor</td> </tr> <tr> <td>8</td> <td>The drive failed to correctly read the menu table from the module during drive power up</td> </tr> <tr> <td>9</td> <td>The drive failed to upload menu tables from the module and timed out (5 s)</td> </tr> <tr> <td>10</td> <td>Menu table CRC invalid</td> </tr> </tbody> </table>	Sub-trip	Reason	1	The module category cannot be identified	2	All the required customized menu table information has not been supplied or the tables supplied are corrupt	3	There is insufficient memory available to allocate the comms buffers for this module	4	The module has not indicated that it is running correctly during drive power-up	5	Module has been removed after power-up or it has stopped working	6	The module has not indicated that it has stopped accessing drive parameters during a drive mode change	7	The module has failed to acknowledge that a request has been made to reset the drive processor	8	The drive failed to correctly read the menu table from the module during drive power up	9	The drive failed to upload menu tables from the module and timed out (5 s)	10	Menu table CRC invalid
	Sub-trip	Reason																					
	1	The module category cannot be identified																					
	2	All the required customized menu table information has not been supplied or the tables supplied are corrupt																					
	3	There is insufficient memory available to allocate the comms buffers for this module																					
	4	The module has not indicated that it is running correctly during drive power-up																					
	5	Module has been removed after power-up or it has stopped working																					
	6	The module has not indicated that it has stopped accessing drive parameters during a drive mode change																					
	7	The module has failed to acknowledge that a request has been made to reset the drive processor																					
	8	The drive failed to correctly read the menu table from the module during drive power up																					
9	The drive failed to upload menu tables from the module and timed out (5 s)																						
10	Menu table CRC invalid																						
Recommended actions:	<ul style="list-style-type: none"> Ensure the Ethernet interface is installed correctly Hardware fault - Contact the supplier of the drive. 																						
Slot4 Not Fitted	Ethernet interface in slot 4 has been removed (Unidrive M700 / M702)																						
253	The <i>Slot4 Not Fitted</i> trip indicates that the Ethernet interface in slot 4 on the drive has been removed since the last power-up.																						
	Recommended actions:																						
	<ul style="list-style-type: none"> Ensure the Ethernet interface is installed correctly Hardware fault - Contact the supplier of the drive. 																						
Slot4 Watchdog	Ethernet interface watchdog service error (Unidrive M700 / M702)																						
251	The <i>Slot4 Watchdog</i> trip indicates that the Ethernet interface installed in slot 4 has started the option watchdog function and then failed to service the watchdog correctly.																						
	Recommended actions:																						
	<ul style="list-style-type: none"> Hardware fault - Contact the supplier of the drive. 																						
Slot App Menu	Application menu Customization conflict error																						
216	The Slot App Menu trip indicates that more than one option slot has requested to customize the application menus 18, 19 and 20. The sub-trip number indicates which option slot has been allowed to customize the menus.																						
	Recommended actions:																						
	<ul style="list-style-type: none"> Ensure that only one of the Application modules is configured to customize the application menus 18, 19 and 20 																						
SlotX Different	Option module in option slot X has changed																						
204 209 214	The <i>SlotX Different</i> trip indicates that the option module in option slot X on the drive is a different type to that installed when parameters were last saved on the drive. The sub-trip number gives the identification code of the module that was originally fitted. The reason for the trip can be identified by the sub-trip number.																						
	<table border="1"> <thead> <tr> <th>Sub-trip</th> <th>Reason</th> </tr> </thead> <tbody> <tr> <td>1</td> <td>No module was installed previously</td> </tr> <tr> <td>2</td> <td>A module with the same identifier is installed, but the set-up menu for this option slot has been changed, and so default parameters have been loaded for this menu.</td> </tr> <tr> <td>3</td> <td>A module with the same identifier is installed, but the applications menu for this option slot has been changed, and so default parameters have been loaded for this menu.</td> </tr> <tr> <td>4</td> <td>A module with the same identifier is installed, but the set-up and applications menu for this option slot have been changed, and so default parameters have been loaded for these menus.</td> </tr> <tr> <td>>99</td> <td>Shows the identifier of the module previously installed.</td> </tr> </tbody> </table>	Sub-trip	Reason	1	No module was installed previously	2	A module with the same identifier is installed, but the set-up menu for this option slot has been changed, and so default parameters have been loaded for this menu.	3	A module with the same identifier is installed, but the applications menu for this option slot has been changed, and so default parameters have been loaded for this menu.	4	A module with the same identifier is installed, but the set-up and applications menu for this option slot have been changed, and so default parameters have been loaded for these menus.	>99	Shows the identifier of the module previously installed.										
	Sub-trip	Reason																					
	1	No module was installed previously																					
	2	A module with the same identifier is installed, but the set-up menu for this option slot has been changed, and so default parameters have been loaded for this menu.																					
3	A module with the same identifier is installed, but the applications menu for this option slot has been changed, and so default parameters have been loaded for this menu.																						
4	A module with the same identifier is installed, but the set-up and applications menu for this option slot have been changed, and so default parameters have been loaded for these menus.																						
>99	Shows the identifier of the module previously installed.																						
	Recommended actions:																						
	<ul style="list-style-type: none"> Turn off the power, ensure the correct option modules are installed in the correct option slots and re-apply the power. Confirm that the currently installed option module is correct, ensure option module parameters are set correctly and perform a user save in Pr mm.000. 																						

Trip	Diagnosis																						
SlotX Error	Option module in option slot X has detected a fault																						
202 207 212	The <i>SlotX Error</i> trip indicates that the option module in option slot X on the drive has detected an error. The reason for the error can be identified by the sub-trip number. Recommended actions: <ul style="list-style-type: none"> See the relevant <i>Option Module User Guide</i> for details of the trip 																						
SlotX HF	Option module X hardware fault																						
200 205 210	The <i>SlotX HF</i> trip indicates that the option module in option slot X cannot operate. The possible causes of the trip can be identified by the sub-trip number. <table border="1"> <thead> <tr> <th>Sub-trip</th> <th>Reason</th> </tr> </thead> <tbody> <tr> <td>1</td> <td>The module category cannot be identified</td> </tr> <tr> <td>2</td> <td>All the required customized menu table information has not been supplied or the tables supplied are corrupt</td> </tr> <tr> <td>3</td> <td>There is insufficient memory available to allocate the comms buffers for this module</td> </tr> <tr> <td>4</td> <td>The module has not indicated that it is running correctly during drive power-up</td> </tr> <tr> <td>5</td> <td>Module has been removed after power-up or it has stopped working</td> </tr> <tr> <td>6</td> <td>The module has not indicated that it has stopped accessing drive parameters during a drive mode change</td> </tr> <tr> <td>7</td> <td>The module has failed to acknowledge that a request has been made to reset the drive processor</td> </tr> <tr> <td>8</td> <td>The drive failed to correctly read the menu table from the module during drive power up</td> </tr> <tr> <td>9</td> <td>The drive failed to upload menu tables from the module and timed out (5 s)</td> </tr> <tr> <td>10</td> <td>Menu table CRC invalid</td> </tr> </tbody> </table> Recommended actions: <ul style="list-style-type: none"> Ensure the option module is installed correctly Replace the option module Replace the drive 	Sub-trip	Reason	1	The module category cannot be identified	2	All the required customized menu table information has not been supplied or the tables supplied are corrupt	3	There is insufficient memory available to allocate the comms buffers for this module	4	The module has not indicated that it is running correctly during drive power-up	5	Module has been removed after power-up or it has stopped working	6	The module has not indicated that it has stopped accessing drive parameters during a drive mode change	7	The module has failed to acknowledge that a request has been made to reset the drive processor	8	The drive failed to correctly read the menu table from the module during drive power up	9	The drive failed to upload menu tables from the module and timed out (5 s)	10	Menu table CRC invalid
Sub-trip	Reason																						
1	The module category cannot be identified																						
2	All the required customized menu table information has not been supplied or the tables supplied are corrupt																						
3	There is insufficient memory available to allocate the comms buffers for this module																						
4	The module has not indicated that it is running correctly during drive power-up																						
5	Module has been removed after power-up or it has stopped working																						
6	The module has not indicated that it has stopped accessing drive parameters during a drive mode change																						
7	The module has failed to acknowledge that a request has been made to reset the drive processor																						
8	The drive failed to correctly read the menu table from the module during drive power up																						
9	The drive failed to upload menu tables from the module and timed out (5 s)																						
10	Menu table CRC invalid																						
SlotX Not Fitted	Option module in option slot X has been removed																						
203 208 213	The <i>SlotX Not Fitted</i> trip indicates that the option module in option slot X on the drive has been removed since the last power up. Recommended actions: <ul style="list-style-type: none"> Ensure the option module is installed correctly. Re-install the option module. To confirm that the removed option module is no longer required perform a save function in Pr mm.000. 																						
SlotX Watchdog	Option module watchdog function service error																						
201 206 211	The <i>SlotX Watchdog</i> trip indicates that the option module installed in Slot X has started the option watchdog function and then failed to service the watchdog correctly. Recommended actions: <ul style="list-style-type: none"> Replace the option module 																						
Soft Start	Soft start relay failed to close, soft start monitor failed																						
226	The <i>Soft Start</i> trip indicates that the soft start relay in the drive failed to close or the soft start monitoring circuit has failed. Recommended actions: <ul style="list-style-type: none"> Hardware fault – Contact the supplier of the drive 																						
Stored HF	Hardware trip has occurred during last power down																						
221	The <i>Stored HF</i> trip indicates that a hardware trip (HF01 –HF20) has occurred and the drive has been power cycled. The sub-trip number identifies the HF trip i.e. stored HF.17. Recommended actions: <ul style="list-style-type: none"> Enter 1299 in Pr mm.000 and press reset to clear the trip 																						

Trip	Diagnosis																																																								
Sub-array RAM	RAM allocation error																																																								
227	<p>The Sub-array RAM indicates that an option module, derivative image or user program image has requested more parameter RAM than is allowed. The RAM allocation is checked in order of resulting sub-trip numbers, and so the failure with the highest sub-trip number is given. The sub-trip is calculated as (parameter size) + (parameter type) + sub-array number.</p> <table border="1"> <thead> <tr> <th>Parameter size</th> <th>Value</th> </tr> </thead> <tbody> <tr> <td>1 bit</td> <td>1000</td> </tr> <tr> <td>8 bit</td> <td>2000</td> </tr> <tr> <td>16 bit</td> <td>3000</td> </tr> <tr> <td>32 bit</td> <td>4000</td> </tr> <tr> <td>64 bit</td> <td>5000</td> </tr> </tbody> </table> <table border="1"> <thead> <tr> <th>Parameter type</th> <th>Value</th> </tr> </thead> <tbody> <tr> <td>Volatile</td> <td>0</td> </tr> <tr> <td>User save</td> <td>100</td> </tr> <tr> <td>Power-down save</td> <td>200</td> </tr> </tbody> </table> <table border="1"> <thead> <tr> <th>Sub-array</th> <th>Menus</th> <th>Value</th> </tr> </thead> <tbody> <tr> <td>Applications menus</td> <td>18-20</td> <td>1</td> </tr> <tr> <td>Derivative image</td> <td>29</td> <td>2</td> </tr> <tr> <td>User program image</td> <td>30</td> <td>3</td> </tr> <tr> <td>Option slot 1 set-up</td> <td>15</td> <td>4</td> </tr> <tr> <td>Option slot 1 applications</td> <td>25</td> <td>5</td> </tr> <tr> <td>Option slot 2 set-up</td> <td>16</td> <td>6</td> </tr> <tr> <td>Option slot 2 applications</td> <td>26</td> <td>7</td> </tr> <tr> <td>Option slot 3 set-up</td> <td>17</td> <td>8</td> </tr> <tr> <td>Option slot 3 applications</td> <td>27</td> <td>9</td> </tr> <tr> <td>Option slot 4 set-up</td> <td>24</td> <td>10</td> </tr> <tr> <td>Option slot 4 applications</td> <td>28</td> <td>11</td> </tr> </tbody> </table>	Parameter size	Value	1 bit	1000	8 bit	2000	16 bit	3000	32 bit	4000	64 bit	5000	Parameter type	Value	Volatile	0	User save	100	Power-down save	200	Sub-array	Menus	Value	Applications menus	18-20	1	Derivative image	29	2	User program image	30	3	Option slot 1 set-up	15	4	Option slot 1 applications	25	5	Option slot 2 set-up	16	6	Option slot 2 applications	26	7	Option slot 3 set-up	17	8	Option slot 3 applications	27	9	Option slot 4 set-up	24	10	Option slot 4 applications	28	11
	Parameter size	Value																																																							
	1 bit	1000																																																							
	8 bit	2000																																																							
	16 bit	3000																																																							
	32 bit	4000																																																							
	64 bit	5000																																																							
	Parameter type	Value																																																							
	Volatile	0																																																							
	User save	100																																																							
	Power-down save	200																																																							
	Sub-array	Menus	Value																																																						
Applications menus	18-20	1																																																							
Derivative image	29	2																																																							
User program image	30	3																																																							
Option slot 1 set-up	15	4																																																							
Option slot 1 applications	25	5																																																							
Option slot 2 set-up	16	6																																																							
Option slot 2 applications	26	7																																																							
Option slot 3 set-up	17	8																																																							
Option slot 3 applications	27	9																																																							
Option slot 4 set-up	24	10																																																							
Option slot 4 applications	28	11																																																							
Temp Feedback	Internal thermistor has failed																																																								
218	<p>The <i>Temp Feedback</i> trip indicates that an internal thermistor has failed. The thermistor location can be identified by the sub-trip number.</p> <table border="1"> <thead> <tr> <th>Source</th> <th>xx</th> <th>y</th> <th>zz</th> </tr> </thead> <tbody> <tr> <td>Control PCB</td> <td>00</td> <td>0</td> <td>01: Control PCB thermistor 1 02: Control PCB thermistor 2 03: I/O PCB thermistor</td> </tr> <tr> <td>Power system</td> <td>Power module number</td> <td>0</td> <td>00: Temperature feedback provided via power system comms. <table border="1"> <thead> <tr> <th></th> <th>Frame 7</th> <th>Frame 8</th> <th>Frame 9 & 10</th> </tr> </thead> <tbody> <tr> <td>21:</td> <td>Rectifier thermistor</td> <td>Power PCB thermistor 1</td> <td>SMPS thermistor</td> </tr> <tr> <td>22:</td> <td>Power PCB thermistor</td> <td>Power PCB thermistor 2</td> <td>Heat Sink Fan SMPS thermistor</td> </tr> <tr> <td>23:</td> <td>Power PCB thermistor</td> <td>Rectifier thermistor</td> <td>Power PCB thermistor</td> </tr> </tbody> </table> </td> </tr> <tr> <td>Power system</td> <td>01</td> <td>Rectifier number*</td> <td>Always zero</td> </tr> </tbody> </table> <p>* For a parallel power-module system the rectifier number will be zero as it is not possible to determine which rectifier has detected the fault.</p> <p>Recommended actions:</p> <ul style="list-style-type: none"> Hardware fault – Contact the supplier of the drive 	Source	xx	y	zz	Control PCB	00	0	01: Control PCB thermistor 1 02: Control PCB thermistor 2 03: I/O PCB thermistor	Power system	Power module number	0	00: Temperature feedback provided via power system comms. <table border="1"> <thead> <tr> <th></th> <th>Frame 7</th> <th>Frame 8</th> <th>Frame 9 & 10</th> </tr> </thead> <tbody> <tr> <td>21:</td> <td>Rectifier thermistor</td> <td>Power PCB thermistor 1</td> <td>SMPS thermistor</td> </tr> <tr> <td>22:</td> <td>Power PCB thermistor</td> <td>Power PCB thermistor 2</td> <td>Heat Sink Fan SMPS thermistor</td> </tr> <tr> <td>23:</td> <td>Power PCB thermistor</td> <td>Rectifier thermistor</td> <td>Power PCB thermistor</td> </tr> </tbody> </table>		Frame 7	Frame 8	Frame 9 & 10	21:	Rectifier thermistor	Power PCB thermistor 1	SMPS thermistor	22:	Power PCB thermistor	Power PCB thermistor 2	Heat Sink Fan SMPS thermistor	23:	Power PCB thermistor	Rectifier thermistor	Power PCB thermistor	Power system	01	Rectifier number*	Always zero																								
	Source	xx	y	zz																																																					
	Control PCB	00	0	01: Control PCB thermistor 1 02: Control PCB thermistor 2 03: I/O PCB thermistor																																																					
	Power system	Power module number	0	00: Temperature feedback provided via power system comms. <table border="1"> <thead> <tr> <th></th> <th>Frame 7</th> <th>Frame 8</th> <th>Frame 9 & 10</th> </tr> </thead> <tbody> <tr> <td>21:</td> <td>Rectifier thermistor</td> <td>Power PCB thermistor 1</td> <td>SMPS thermistor</td> </tr> <tr> <td>22:</td> <td>Power PCB thermistor</td> <td>Power PCB thermistor 2</td> <td>Heat Sink Fan SMPS thermistor</td> </tr> <tr> <td>23:</td> <td>Power PCB thermistor</td> <td>Rectifier thermistor</td> <td>Power PCB thermistor</td> </tr> </tbody> </table>		Frame 7	Frame 8	Frame 9 & 10	21:	Rectifier thermistor	Power PCB thermistor 1	SMPS thermistor	22:	Power PCB thermistor	Power PCB thermistor 2	Heat Sink Fan SMPS thermistor	23:	Power PCB thermistor	Rectifier thermistor	Power PCB thermistor																																					
		Frame 7	Frame 8	Frame 9 & 10																																																					
21:	Rectifier thermistor	Power PCB thermistor 1	SMPS thermistor																																																						
22:	Power PCB thermistor	Power PCB thermistor 2	Heat Sink Fan SMPS thermistor																																																						
23:	Power PCB thermistor	Rectifier thermistor	Power PCB thermistor																																																						
Power system	01	Rectifier number*	Always zero																																																						
Th Brake Res	Brake resistor over temperature																																																								
10	<p>The <i>Th Brake Res</i> is initiated, If hardware based braking resistor thermal monitoring is connected and the resistor overheats. If the braking resistor is not used then this trip must be disabled with bit 3 of Action <i>On Trip Detection</i> (10.037) to prevent this trip.</p> <p>Recommended actions:</p> <ul style="list-style-type: none"> Check brake resistor wiring Check braking resistor value is greater than or equal to the minimum resistance value Check braking resistor insulation 																																																								

Trip	Diagnosis						
Th Short Circuit	Motor thermistor short circuit						
25	The <i>Th Short Circuit</i> trip indicates that the motor thermistor connected to the drive is short circuit or low impedance i.e. < 50 Ω. The location of the trip can be identified by the sub-trip number.						
	<table border="1"> <thead> <tr> <th>Sub-trip</th> <th>Source</th> </tr> </thead> <tbody> <tr> <td>3</td> <td>Analog input 3</td> </tr> <tr> <td>4</td> <td>Position feedback interface</td> </tr> </tbody> </table>	Sub-trip	Source	3	Analog input 3	4	Position feedback interface
	Sub-trip	Source					
	3	Analog input 3					
4	Position feedback interface						
Recommended actions: <ul style="list-style-type: none"> • Check thermistor continuity • Replace motor / motor thermistor 							
Thermistor	Motor thermistor over-temperature						
24	The <i>Thermistor</i> trip indicates that the motor thermistor connected to the drive has indicated a motor over temperature. The location of the trip can be identified by the sub-trip number.						
	<table border="1"> <thead> <tr> <th>Sub-trip</th> <th>Source</th> </tr> </thead> <tbody> <tr> <td>3</td> <td>Analog input 3</td> </tr> <tr> <td>4</td> <td>Position feedback interface</td> </tr> </tbody> </table>	Sub-trip	Source	3	Analog input 3	4	Position feedback interface
	Sub-trip	Source					
	3	Analog input 3					
4	Position feedback interface						
Recommended actions: <ul style="list-style-type: none"> • Check motor temperature • Check <i>Threshold Level</i> (07.048) • Check thermistor continuity 							
Undefined	Drive has tripped and the cause of the trip is Undefined						
110	The <i>Undefined</i> trip indicates that the power system has generated but did not identify the trip from the power system. The cause of the trip is unknown.						
	Recommended actions: <ul style="list-style-type: none"> • Hardware fault – return the drive to the supplier 						
User 24V	User 24 V supply is not present on control terminals (1,2)						
91	A <i>User 24 V</i> trip is initiated, if <i>User Supply Select</i> (Pr 06.072) is set to 1 or <i>Low Under Voltage Threshold Select</i> (06.067) = 1 or <i>Backup Supply Mode Enable</i> (06.068) = 1 and no user 24 V supply is present on control terminals 1 and 2.						
	Recommended actions: <ul style="list-style-type: none"> • Ensure the user 24 V supply is present on control terminals 1 (0V) and 2 (24V) 						

Trip	Diagnosis																																																																																																	
User Program	On board user program error																																																																																																	
	The <i>User Program</i> trip indicates that an error has been detected in the onboard user program image. The reason for the trip can be identified by the sub-trip number.																																																																																																	
	<table border="1"> <thead> <tr> <th>Sub-trip</th> <th>Reason</th> <th>Comments</th> </tr> </thead> <tbody> <tr> <td>1</td> <td>Divide by zero</td> <td></td> </tr> <tr> <td>2</td> <td>Undefined trip</td> <td></td> </tr> <tr> <td>3</td> <td>Attempted fast parameter access set-up with non-existent parameter</td> <td></td> </tr> <tr> <td>4</td> <td>Attempted access to non-existent parameter</td> <td></td> </tr> <tr> <td>5</td> <td>Attempted write to read-only parameter</td> <td></td> </tr> <tr> <td>6</td> <td>Attempted an over-range write</td> <td></td> </tr> <tr> <td>7</td> <td>Attempted read from write-only parameter</td> <td></td> </tr> <tr> <td>30</td> <td>The image has failed because either its CRC is incorrect, or there are less than 6 bytes in the image or the image header version is less than 5.</td> <td>Occurs when the drive powers-up or the image is programmed. The image tasks will not run</td> </tr> <tr> <td>31</td> <td>The image requires more RAM for heap and stack than can be provided by the drive.</td> <td>As 30</td> </tr> <tr> <td>32</td> <td>The image requires an OS function call that is higher than the maximum allowed</td> <td>As 30</td> </tr> <tr> <td>33</td> <td>The ID code within the image is not valid</td> <td>As 30</td> </tr> <tr> <td>40</td> <td>The timed task has not completed in time and has been suspended</td> <td><i>Onboard User Program: Enable</i> (11.047) is reset to zero when the trip is initiated</td> </tr> <tr> <td>41</td> <td>Undefined function called, i.e. a function in the host system vector table that has not been assigned.</td> <td>As 40</td> </tr> <tr> <td>52</td> <td>Customized menu table CRC check failed</td> <td>As 30</td> </tr> <tr> <td>53</td> <td>Customized menu table changed</td> <td>Occurs when the drive powers-up or the image is programmed and the table has changed. Defaults are loaded for the user program menu and the trip will keep occurring until drive parameters are saved.</td> </tr> <tr> <td>80</td> <td>Image is not compatible with the control board</td> <td>Initiated from within the image code</td> </tr> <tr> <td>81</td> <td>Image is not compatible with the control board serial number</td> <td>As 80</td> </tr> <tr> <td>100</td> <td>Image has detected and prevented attempted pointer access outside of the IEC task's heap area.</td> <td></td> </tr> <tr> <td>101</td> <td>Image has detected and prevented misaligned pointer usage.</td> <td></td> </tr> <tr> <td>102</td> <td>Image has detected an array bounds violation and prevented its access.</td> <td></td> </tr> <tr> <td>103</td> <td>Image has attempted to convert a data type to or from an unknown data type, has failed and has shut itself down.</td> <td></td> </tr> <tr> <td>104</td> <td>Image has attempted to use an unknown user service function.</td> <td></td> </tr> <tr> <td>200</td> <td>User program has invoked a "divide" service with a denominator of zero. (Note that this is raised by the downloaded image and has therefore been given a distinct error code despite being the same fundamental problem as sub-trip 1.)</td> <td></td> </tr> <tr> <td>201</td> <td>Parameter access is not supported. An attempt to read database other than the host drive.</td> <td></td> </tr> <tr> <td>202</td> <td>Parameter does not exist. Database was host drive but the specified parameter does not exist.</td> <td></td> </tr> <tr> <td>203</td> <td>Parameter is read-only.</td> <td></td> </tr> <tr> <td>204</td> <td>Parameter is write-only.</td> <td></td> </tr> <tr> <td>205</td> <td>Unknown parameter error.</td> <td></td> </tr> <tr> <td>206</td> <td>Invalid bit present in parameter. The parameter does not contain the specified bit.</td> <td></td> </tr> <tr> <td>207</td> <td>Parameter format lookup failed. Failed to get parameter information data.</td> <td></td> </tr> <tr> <td>208</td> <td>An over-range write has been attempted.</td> <td></td> </tr> </tbody> </table>	Sub-trip	Reason	Comments	1	Divide by zero		2	Undefined trip		3	Attempted fast parameter access set-up with non-existent parameter		4	Attempted access to non-existent parameter		5	Attempted write to read-only parameter		6	Attempted an over-range write		7	Attempted read from write-only parameter		30	The image has failed because either its CRC is incorrect, or there are less than 6 bytes in the image or the image header version is less than 5.	Occurs when the drive powers-up or the image is programmed. The image tasks will not run	31	The image requires more RAM for heap and stack than can be provided by the drive.	As 30	32	The image requires an OS function call that is higher than the maximum allowed	As 30	33	The ID code within the image is not valid	As 30	40	The timed task has not completed in time and has been suspended	<i>Onboard User Program: Enable</i> (11.047) is reset to zero when the trip is initiated	41	Undefined function called, i.e. a function in the host system vector table that has not been assigned.	As 40	52	Customized menu table CRC check failed	As 30	53	Customized menu table changed	Occurs when the drive powers-up or the image is programmed and the table has changed. Defaults are loaded for the user program menu and the trip will keep occurring until drive parameters are saved.	80	Image is not compatible with the control board	Initiated from within the image code	81	Image is not compatible with the control board serial number	As 80	100	Image has detected and prevented attempted pointer access outside of the IEC task's heap area.		101	Image has detected and prevented misaligned pointer usage.		102	Image has detected an array bounds violation and prevented its access.		103	Image has attempted to convert a data type to or from an unknown data type, has failed and has shut itself down.		104	Image has attempted to use an unknown user service function.		200	User program has invoked a "divide" service with a denominator of zero. (Note that this is raised by the downloaded image and has therefore been given a distinct error code despite being the same fundamental problem as sub-trip 1.)		201	Parameter access is not supported. An attempt to read database other than the host drive.		202	Parameter does not exist. Database was host drive but the specified parameter does not exist.		203	Parameter is read-only.		204	Parameter is write-only.		205	Unknown parameter error.		206	Invalid bit present in parameter. The parameter does not contain the specified bit.		207	Parameter format lookup failed. Failed to get parameter information data.		208	An over-range write has been attempted.		
Sub-trip	Reason	Comments																																																																																																
1	Divide by zero																																																																																																	
2	Undefined trip																																																																																																	
3	Attempted fast parameter access set-up with non-existent parameter																																																																																																	
4	Attempted access to non-existent parameter																																																																																																	
5	Attempted write to read-only parameter																																																																																																	
6	Attempted an over-range write																																																																																																	
7	Attempted read from write-only parameter																																																																																																	
30	The image has failed because either its CRC is incorrect, or there are less than 6 bytes in the image or the image header version is less than 5.	Occurs when the drive powers-up or the image is programmed. The image tasks will not run																																																																																																
31	The image requires more RAM for heap and stack than can be provided by the drive.	As 30																																																																																																
32	The image requires an OS function call that is higher than the maximum allowed	As 30																																																																																																
33	The ID code within the image is not valid	As 30																																																																																																
40	The timed task has not completed in time and has been suspended	<i>Onboard User Program: Enable</i> (11.047) is reset to zero when the trip is initiated																																																																																																
41	Undefined function called, i.e. a function in the host system vector table that has not been assigned.	As 40																																																																																																
52	Customized menu table CRC check failed	As 30																																																																																																
53	Customized menu table changed	Occurs when the drive powers-up or the image is programmed and the table has changed. Defaults are loaded for the user program menu and the trip will keep occurring until drive parameters are saved.																																																																																																
80	Image is not compatible with the control board	Initiated from within the image code																																																																																																
81	Image is not compatible with the control board serial number	As 80																																																																																																
100	Image has detected and prevented attempted pointer access outside of the IEC task's heap area.																																																																																																	
101	Image has detected and prevented misaligned pointer usage.																																																																																																	
102	Image has detected an array bounds violation and prevented its access.																																																																																																	
103	Image has attempted to convert a data type to or from an unknown data type, has failed and has shut itself down.																																																																																																	
104	Image has attempted to use an unknown user service function.																																																																																																	
200	User program has invoked a "divide" service with a denominator of zero. (Note that this is raised by the downloaded image and has therefore been given a distinct error code despite being the same fundamental problem as sub-trip 1.)																																																																																																	
201	Parameter access is not supported. An attempt to read database other than the host drive.																																																																																																	
202	Parameter does not exist. Database was host drive but the specified parameter does not exist.																																																																																																	
203	Parameter is read-only.																																																																																																	
204	Parameter is write-only.																																																																																																	
205	Unknown parameter error.																																																																																																	
206	Invalid bit present in parameter. The parameter does not contain the specified bit.																																																																																																	
207	Parameter format lookup failed. Failed to get parameter information data.																																																																																																	
208	An over-range write has been attempted.																																																																																																	
249																																																																																																		

Trip	Diagnosis
User Prog Trip	Trip generated by an onboard user program
96	This trip can be initiated from within an onboard user program using a function call which defines the sub-trip number. Recommended actions: <ul style="list-style-type: none"> • Check the user program
User Save	User Save error / not completed
36	The <i>User Save</i> trip indicates that an error has been detected in the user save parameters saved in non-volatile memory. For example, following a user save command, if the power to the drive was removed when the user parameters were being saved. Recommended actions: <ul style="list-style-type: none"> • Perform a user save in Pr mm.000 to ensure that the trip doesn't occur the next time the drive is powered up. • Ensure that the drive has enough time to complete the save before removing the power to the drive.
User Trip	User generated trip
40 -89 112 -159	These trips are not generated by the drive and are to be used by the user to trip the drive through an application program. Recommended actions: <ul style="list-style-type: none"> • Check the user program
Voltage Range	Supply voltage out of range detected in Regen mode
169	The <i>Voltage Range</i> trip is initiated, if the Regen <i>Minimum Voltage</i> (03.026) is set to a non-zero value and the supply voltage is outside the range defined by <i>Regen Maximum Voltage</i> (03.027) and <i>Regen Minimum Voltage</i> (03.026) for more than 100 ms. Recommended actions: <ul style="list-style-type: none"> • Ensure the supply voltage is operating within the drive specification. • Ensure Pr 03.026 and Pr 03.027 are set correctly • Check the supply voltage waveform using an oscilloscope • Reduce the level of supply disturbance • Set <i>Maximum Voltage</i> (03.027) to zero to disable the trip.
Watchdog	Control word watchdog has timed out
30	The <i>Watchdog</i> trip indicates that the control word has been enabled and has timed out. Recommended actions: <p>Once Pr 06.042 bit 14 has been changed from 0 to 1 to enable the watchdog, this must be repeated every 1 s or a Watchdog trip will be initiated. The watchdog is disabled when the trip occurs and must be re-enabled if required when the trip is reset.</p>

Table 13-5 Serial communications look up table

No	Trip	No	Trip	No	Trip
1	Reserved 001	94	Rectifier Set-up	195	Encoder 7
2	Over Volts	95	Reserved 95	196	Encoder 8
3	OI ac	96	User Prog Trip	198	Phasing Error
4	OI Brake	97	Data Changing	199	Destination
5	PSU	98	Out Phase Loss	200	Slot1 HF
6	External Trip	99	CAM	201	Slot1 Watchdog
7	Over Speed	100	Reset	202	Slot1 Error
8	Inductance	101	OHT Brake	203	Slot1 Not Fitted
9	PSU 24V	102	Reserved 102	204	Slot1 Different
10	Th Brake Res	103	Inter-connect	205	Slot2 HF
11	Autotune 1	104 - 108	Reserved 104 - 108	206	Slot2 Watchdog
12	Autotune 2	109	OI dc	207	Slot2 Error
13	Autotune 3	110	Undefined	208	Slot2 Not Fitted
14	Autotune 4	111	Configuration	209	Slot2 Different
15	Autotune 5	112 - 159	User Trip 112 - 159	210	Slot3 HF
16	Autotune 6	160	Island	211	Slot3 Watchdog
17	Autotune 7	161	Reserved	212	Slot3 Error
18	Autotune Stopped	162	Encoder 12	213	Slot3 Not Fitted
19	Brake R Too Hot	163	Encoder 13	214	Slot3 Different
20	Motor Too Hot	164	Encoder 14	215	Option Disable
21	OHT Inverter	165 - 168	Reserved 165 - 168	216	Slot App Menu
22	OHT Power	169	Voltage Range	217	App Menu Changed
23	OHT Control	170 - 173	Reserved 170 - 173	218	Temp Feedback
24	Thermistor	174	Card Slot	219	An Output Calib
25	Th Short Circuit	175	Card Product	220	Power Data
26	I/O Overload	176	Name Plate	221	Stored HF
27	OHT dc bus	177	Card Boot	222	Reserved 222
28	An Input Loss 1	178	Card Busy	223	Rating Mismatch
29	An Input Loss 2	179	Card Data Exists	224	Drive Size
30	Watchdog	180	Card Option	225	Current Offset
31	EEPROM Fail	181	Card Read Only	226	Soft Start
32	Phase Loss	182	Card Error	227	Sub-array RAM
33	Resistance	183	Card No Data	228 - 246	Reserved 228 - 246
34	Keypad Mode	184	Card Full	247	Derivative ID
35	Control Word	185	Card Access	248	Derivative Image
36	User Save	186	Card Rating	249	User Program
37	Power Down Save	187	Card Drive Mode	250	Slot4 HF
38	Low Load	188	Card Compare	251	Slot4 Watchdog
39	Line Sync	189	Encoder 1	252	Slot4 Error
40 -89	User Trip 40 - 89	190	Encoder 2	253	Slot4 Not Fitted
90	Power Comms	191	Encoder 3	254	Slot4 Different
91	User 24V	192	Encoder 4	255	Reset Logs
92	OI Snubber	193	Encoder 5		
93	Inductor Too Hot	194	Encoder 6		

The trips can be grouped into the following categories. It should be noted that a trip can only occur when the drive is not tripped or is already tripped but with a trip with a lower priority number.

Table 13-6 Trip categories

Priority	Category	Trips	Comments
1	Internal faults	HFxx	These indicate internal problems and cannot be reset. All drive features are inactive after any of these trips occur. If an KI-Keypad is installed it will show the trip, but the keypad will not function.
1	Stored HF trip	{Stored HF}	This trip cannot be cleared unless 1299 is entered into <i>Parameter (mm.000)</i> and a reset is initiated.
2	Non-resettable trips	Trip numbers 218 to 247, {Slot1 HF}, {Slot2 HF}, {Slot3 HF} or {Slot4 HF}	These trips cannot be reset.
3	Volatile memory failure	{EEPROM Fail}	This can only be reset if Parameter mm.000 is set to 1233 or 1244, or if <i>Load Defaults (11.043)</i> is set to a non-zero value.
4	NV Media Card trips	Trip numbers 174, 175 and 177 to 188	These trips are priority 5 during power-up.
4	Internal 24V and position feedback interface power supply	{PSU 24V} and {Encoder 1}	These trips can override {Encoder 2} to {Encoder 6} trips.
5	Trips with extended reset times	{OI ac}, {OI Brake}, and OI dc}	These trips cannot be reset until 10 s after the trip was initiated.
5	Phase loss and d.c. link power circuit protection	{Phase Loss} and {Oht dc bus}	The drive will attempt to stop the motor before tripping if a {Phase Loss}.000 trip occurs unless this feature has been disabled (see <i>Action On Trip Detection (10.037)</i>). The drive will always attempt to stop the motor before tripping if an {Oht dc bus} occurs.
5	Standard trips	All other trips	

13.5 Internal / Hardware trips

Trips {HF01} to {HF25} are internal faults that do not have trip numbers. If one of these trips occurs, the main drive processor has detected an irrecoverable error. All drive functions are stopped and the trip message will be displayed on the drive keypad. If a non permanent trip occurs this may be reset by power cycling the drive. On power up after it has been power cycled the drive will trip on Stored HF. The sub-trip code is the number of the original HF trip. Enter 1299 in **mm.000** to clear the Stored HF trip.

13.6 Alarm indications

In any mode, an alarm is an indication given on the display by alternating the alarm string with the drive status string on the first row and showing the alarm symbol in the last character in the first row. If an action is not taken to eliminate any alarm except "Auto Tune and Limit Switch" the drive may eventually trip. Alarms are not displayed when a parameter is being edited, but the user will still see the alarm character on the upper row.

Table 13-7 Alarm indications

Alarm string	Description
Brake Resistor	Brake resistor overload. <i>Braking Resistor Thermal Accumulator</i> (10.039) in the drive has reached 75.0 % of the value at which the drive will trip.
Motor Overload	<i>Motor Protection Accumulator</i> (04.019) in the drive has reached 75.0 % of the value at which the drive will trip and the load on the drive is >100 %.
Ind Overload	Regen inductor overload. <i>Inductor Protection Accumulator</i> (04.019) in the drive has reached 75.0 % of the value at which the drive will trip and the load on the drive is >100 %.
Drive Overload	Drive over temperature. <i>Percentage Of Drive Thermal Trip Level</i> (07.036) in the drive is greater than 90 %.
Auto Tune	The autotune procedure has been initialized and an autotune in progress.
Limit Switch	Limit switch active. Indicates that a limit switch is active and that is causing the motor to be stopped.

13.7 Status indications

Table 13-8 Status indications

Upper row string	Description	Drive output stage
Inhibit	The drive is inhibited and cannot be run. The Safe Torque Off signal is not applied to Safe Torque Off terminals or Pr 06.015 is set to 0	Disabled
Ready	The drive is ready to run. The drive enable is active, but the drive inverter is not active because the final drive run is not active	Disabled
Stop	The drive is stopped / holding zero speed.	Enabled
Run	The drive is active and running	Enabled
Scan	The drive is enabled in Regen mode and is trying to synchronize to the supply	Enabled
Supply Loss	Supply loss condition has been detected	Enabled
Deceleration	The motor is being decelerated to zero speed / frequency because the final drive run has been deactivated.	Enabled
dc injection	The drive is applying dc injection braking	Enabled
Position	Positioning / position control is active during an orientation stop	Enabled
Trip	The drive has tripped and no longer controlling the motor. The trip code appears in the lower display	Disabled
Active	The regen unit is enabled and synchronized to the supply	Enabled
Under Voltage	The drive is in the under voltage state either in low voltage or high voltage mode	Disabled
Heat	The motor pre-heat function is active	Enabled
Phasing	The drive is performing a 'phasing test on enable'.	Enabled

Table 13-9 Option module and NV Media Card and other status indications at power-up

First row string	Second row string	Status
Booting	Parameters	Parameters are being loaded
Drive parameters are being loaded from a NV Media Card		
Booting	User Program	User program being loaded
User program is being loaded from a NV Media Card to the drive		
Booting	Option Program	User program being loaded
User program is being loaded from a NV Media Card to the option module in slot X		
Writing To	NV Card	Data being written to NV Media Card
Data is being written to a NV Media Card to ensure that its copy of the drive parameters is correct because the drive is in Auto or Boot mode		
Waiting For	Power System	Waiting for power stage
The drive is waiting for the processor in the power stage to respond after power-up		
Waiting For	Options	Waiting for an option module
The drive is waiting for the Options Modules to respond after power-up		
Uploading From	Options	Loading parameter database
At power-up it may be necessary to update the parameter database held by the drive because an option module has changed or because an applications module has requested changes to the parameter structure. This may involve data transfer between the drive an option modules. During this period 'Uploading From Options' is displayed		

13.8 Programming error indications

Following are the error message displayed on the drive keypad when an error occurs during programming of drive firmware.

Table 13-10 Programming error indications

Error String	Reason	Solution
Error 1	There is not enough drive memory requested by all the option modules.	Power down drive and remove some of the option modules until the message disappears.
Error 2	At least one option module did not acknowledge the reset request.	Power cycle drive
Error 3	The boot loader failed to erase the processor flash	Power cycle drive and try again. If problem persists, return drive
Error 4	The boot loader failed to program the processor flash	Power cycle drive and try again. If problem persists, return drive
Error 5	One option module did not initialize correctly. Option module did not set Ready to Run flag.	Remove faulty option module.

13.9 Displaying the trip history

The drive retains a log of the last ten trips that have occurred. *Trip 0* (10.020) to *Trip 9* (10.029) store the most recent 10 trips that have occurred where *Trip 0* (10.020) is the most recent and *Trip 9* (10.029) is the oldest. When a new trip occurs it is written to *Trip 0* (10.020) and all the other trips move down the log, with oldest being lost. The date and time when each trip occurs are also stored in the date and time log, i.e. *Trip 0 Date* (10.041) to *Trip 9 Time* (10.060). The date and time are taken from *Date* (06.016) and *Time* (06.017). Some trips have sub-trip numbers which give more detail about the reason for the trip. If a trip has a sub-trip number its value is stored in the sub-trip log, i.e. *Trip 0 Sub-trip Number* (10.070) to *Trip 9 Sub-trip Number* (10.079). If the trip does not have a sub-trip number then zero is stored in the sub-trip log.

If any parameter between Pr **10.020** and Pr **10.029** inclusive is read by serial communication, then the trip number in Table 13-5 is the value transmitted.

NOTE

The trip logs can be reset by writing a value of 255 in Pr **10.038**.

13.10 Behaviour of the drive when tripped

If the drive trips, the output of the drive is disabled so the load coasts to a stop. If any trip occurs the following read only parameters are frozen until the trip is cleared. This is to help in diagnose the cause of the trip.

Parameter	Description
01.001	Frequency / speed reference
01.002	Pre-skip filter reference
01.003	Pre-ramp reference
02.001	Post-ramp reference
03.001	Frequency slaving demand / Final speed ref
03.002	Speed feedback
03.003	Speed error
03.004	Speed controller output
04.001	Current magnitude
04.002	Active current
04.017	Reactive current
05.001	Output frequency
05.002	Output voltage
05.003	Power
05.005	DC bus voltage
07.001	Analog input 1*
07.002	Analog input 2*
07.003	Analog input 3*

*On *Unidrive M700 / 701* only.

If the parameters are not required to be frozen then this can be disabled by setting bit 4 of Pr **10.037**.

14 UL information

14.1 UL file reference

All models are UL Listed to both Canadian and US requirements. The UL file reference is: NMMS/7.E171230.

Products that incorporate the Safe Torque Off (STO) function are Certified for Functional Safety. The UL file reference is: FSPC.E171230.

14.2 Option modules, kits and accessories

Option Modules, Control Pods, Installation Kits and other accessories for use with these drives are UL Listed.

14.3 Enclosure ratings

With the exception of free-standing cubicle drives, all models are Open Type as supplied.

The drive enclosure is not classified as a fire enclosure. A separate fire enclosure must be provided. A UL/ NEMA Type 12 enclosure is suitable. Refer to relevant *Power Installation Guide for further information*.

When fitted with a conduit box the drives meet the requirements for UL Type 1. Type 1 enclosures are intended for indoor use, primarily to provide a degree of protection against limited amounts of falling dirt.

The drives meet the requirements for UL Type 12 when installed inside a Type 12 enclosure and through-hole mounted using the sealing kit and the high-IP insert (where provided).

When through-hole mounted, the drives have been evaluated as suitable for use in surrounding air temperatures up to 40 °C.

Remote Keypads are UL Type 12 when installed with the sealing washer and fixing kit provided.

When installed in a Type 1 or Type 12 enclosure, the drives may be operated in a compartment handling conditioned air. Refer to relevant *Power Installation Guide for further information*.

14.4 Mounting

Drives may be surface, through-panel or tile mounted using the appropriate brackets. Drives may be mounted singly or side by side with suitable space between them (bookcase mounting). Refer to relevant *Power Installation Guide for further information*.

14.5 Environment

Drives must be installed in a Pollution Degree 2 environment or better (dry, non-conductive pollution only).

The drives have been evaluated for use at ambient temperatures up to 40 °C. The drives have additionally been evaluated for 50 °C and 55 °C ambient air temperatures with a derated output. Refer to relevant *Power Installation Guide for further information*.

14.6 Electrical Installation

OVERVOLTAGE CATEGORY

OVC III

SUPPLY

The drives are suitable for use on a circuit capable of delivering not more than 100,000 RMS symmetrical amperes, 600 Volts AC Maximum.

TERMINAL TORQUE

Terminals must be tightened to the rated torque as specified in the Installation Instructions. Refer to relevant *Power Installation Guide for further information*.

WIRING TERMINALS

Drives must be installed using cables rated for 75 °C operation, copper wire only.

Where possible, UL Listed closed-loop connectors sized according to the field wiring shall be used for all field power wiring connections. Refer to relevant *Power Installation Guide for further information*.

GROUND CONNECTION INSTRUCTIONS

UL Listed closed-loop connectors sized according to the field wiring shall be used for grounding connections. Refer to relevant *Power Installation Guide for further information*.

BRANCH CIRCUIT PROTECTION

The fuses and circuit breakers required for branch circuit protection are specified in the Installation Instructions. Refer to relevant *Power Installation Guide for further information*.

OPENING OF BRANCH CIRCUIT

Opening of the branch-circuit protective device may be an indication that a fault has been interrupted. To reduce the risk of fire or electric shock, the equipment should be examined and replaced if damaged. If burnout of the current element of an overload relay occurs, the complete overload relay must be replaced.

Integral solid state short circuit protection does not provide branch circuit protection. Branch circuit protection must be provided in accordance with the National Electrical Code (NEC), The Canadian Electrical Code, and any additional local codes.

REGENERATIVE OPERATION

Drives can be configured as an AC Regenerative Unit (also known as a Regen drive). Regen operation allows bi-directional power flow to and from the AC supply. The AC supply voltage must not exceed 600 Vac. Contact the supplier of the drive for more information on building a Regen system.

14.7 Motor overload protection and thermal memory retention

All drives incorporate internal overload protection for the motor load that does not require the use of an external or remote overload protection device.

The protection level is adjustable and the method of adjustment is provided in section 8.4 *Motor thermal protection* on page 108. Maximum current overload is dependent on the values entered into the current limit parameters (motoring current limit, regenerative current limit and symmetrical current limit entered as percentage) and the motor rated current parameter (entered in amperes).

The duration of the overload is dependent on motor thermal time constant. The maximum programmable time constant depends on the drive model. The method of adjustment of the overload protection is provided. Refer to the relevant *Power Installation Guide for further information*.

The drives are provided with user terminals that can be connected to a motor thermistor to protect the motor from high temperature, in the event of a motor cooling fan failure. Refer to the relevant *Power Installation Guide for further information*.

14.8 External Class 2 supply

The external power supply used to power the 24 V control circuit shall be marked: "UL Class 2". The power supply voltage shall not exceed 24 Vdc. Refer to the relevant *Power Installation Guide for further information*.

14.9 Modular Drive Systems

Drives with DC+ and DC- supply connections, rated 230 V or 480 V have been investigated for use in Modular Drive Systems as inverters when supplied by the converter sections from the Unidrive-M range. In these applications the inverters are required to be additionally protected by supplemental fuses.

Alternatively, the inverters may be supplied by converter models: Mentor MP25A, 45A, 75A, 105A, 155A or 210A.

Modular drives with frame sizes 9, 10 and 11 are not certified for Canada when used in a modular/parallel setup without DC fuses.

Contact the supplier of the drive for more information.

14.10 Requirement for Transient Surge Suppression

This requirement only applies to Frame Size 7 drives with rated input voltage = 575 V.

TRANSIENT SURGE SUPPRESSION SHALL BE INSTALLED ON THE LINE SIDE OF THIS EQUIPMENT AND SHALL BE RATED 575 Vac (PHASE TO GROUND), 575 Vac (PHASE TO PHASE), SUITABLE FOR OVERVOLTAGE CATEGORY III, AND SHALL PROVIDE PROTECTION FOR A RATED IMPULSE VOLTAGE TO WITHSTAND VOLTAGE PEAK OF 6 kV AND A CLAMPING VOLTAGE OF MAXIMUM 2400 V.

Index

Symbols

+10V user output	26
+24V external input	22, 26, 28, 30, 31
+24V user output	27, 30

Numerics

0V (Common connection for all external devices)	26, 27, 28, 30, 31
--	--------------------

A

Acceleration	58, 78, 79, 80, 81, 83
Addressing	116
Addressing etiquette	116
Advanced EDS File	123
Advanced menus	43
Advanced parameters	145
Alarm	279
Alarm Indications	279
Alternative notation	116
Analog input 2	27
Analog input 3	27
Analog output 1	27
Analog output 2	27
Assembly object	125
Autotune	96

B

Basic requirements	69
Basic speed and torque control	126
Basic speed and torque feedback	128
Basic speed control	125
Basic speed feedback	127

C

Cautions	9
Completing the address	116
Configuring SM-Ethernet cyclic parameters	125
Control connections	24
Control Supervisor object	132
Control Techniques object	134
Current limit	58
Current limits	108
Current loop gains	106
Cyclic (implicit or polled) data transfer	125

D

Deceleration	60, 78, 79, 80, 81, 83
Defaults (restoring parameter)	45
Destination parameter	24, 29
DHCP considerations	116
Diagnostics	245
Digital I/O 1	28
Digital I/O 2	28
Digital I/O 3	28
Digital Input 4	28, 30
Digital Input 5	28, 30
Digital Input 6	28
Digital Output 1	30
Digital Output 2	30
Display	40
Display messages	44
Drive enable	28, 31

E

Encoder feedback limits	109
Encoder types	32
Extended speed and torque control	127
Extended speed and torque feedback	129
Extended speed control	126
Extended speed feedback	128

F

Features / specification	135
Field weakening (constant power) operation	109
Fixed IP addressing	116
Fixed V/F mode	13

G

Getting Started	40
-----------------------	----

H

High speed operation	109
----------------------------	-----

I

IP address	116
------------------	-----

K

Keypad and display - Installing / removing	21
Keypad operation	40

M

Maximum speed / frequency	110
Mechanical Installation	19
Menu 0	43
Menu 01 - Frequency / speed reference	158
Menu 02 - Ramps	162
Menu 03 - Slave frequency, speed feedback and speed control	165
Menu 04 - Torque and current control	176
Menu 05 - Motor control	180
Menu 06 - Sequencer and clock	187
Menu 07 - Analog I/O	191
Menu 08 - Digital I/O	196
Menu 09 - Programmable logic, motorized pot and binary sum	202
Menu 10 - Status and trips	208
Menu 11 - General drive set-up	210
Menu 12 - Threshold detectors and variable selectors	212
Menu 13 - Standard motion controller	220
Menu 14 - User PID controller	224
Menu 18 - Application menu 1	229
Menu 19 - Application menu 2	229
Menu 20 - Application menu 3	229
Menu 21 - Second motor parameters	230
Menu 22 - Additional Menu 0 set-up	232
Menu structure	42
Minimum connections to get the motor running in any operating mode	70
Modbus function codes	116
Mode parameter	24, 29
Monitoring	60
Motor (running the motor)	69
Motor number of poles	95
Motor parameters	66
Motor rated current	95
Motor rated current (maximum)	108
Motor rated frequency	95
Motor rated power factor	95
Motor rated speed	95
Motor rated voltage	95
Motor thermal protection	108

N

Non-cyclic (explicit) data transfer	125
Notes	9
NV media card operation	139

O

Object Model	129
Onboard PLC	143
Open loop mode	13
Open loop vector mode	13
Operating mode (changing)	45, 69
Operating modes	13
Operating-mode selection	67
Optimization	95
Option Module	228
Option Module - Installing / removing	19
Options	16

P

Parameter access level	46
Parameter ranges	148
Parameter security	46
Parameter x.00	58
PLC	135
Position feedback	69
Position feedback connections	31
Position feedback module category parameters	228
Precision reference Analog input 1	26
Product information	11
PROFINET IO communications	136

Q

Quadratic V/F mode	13
Quick start commissioning	83
Quick start commissioning / Start-up	78
Quick start connections	69

R

Ramps	58
Read consistency	124
Registers	116
Relay contacts	28, 31
Requested Packet Interval (RPI) Timeout Trip	123
RFC-A mode	13
RFC-S mode	13
Routing	116

S

Safe Torque Off	37
Safe Torque Off/drive enable	28, 31
Safety Information	9
Saving parameters	45
Serial comms lead	24
Serial communications connections	23
Serial communications look-up table	247
Single line descriptions	49
Source parameter	24
Speed feedback	69
Speed loop gains	101, 104, 106, 107
Speed reference selection	58
Speed-loop PID gains	59
Status	279
Status Indications	279
Status information	67
Subnet mask	116
Supported drive assembly objects	125
Switching frequency	109, 110

T

Trip	245
Trip History	280
Trip Indications	245

U

UL Listing Information	281
Unidrive M700 / M701 Control terminal specification	26
Unidrive M700 / M702 Ethernet fieldbus communications	23
Unidrive M702 - Control terminal specification	30
User Security	46

V

Voltage boost59
Voltage mode 96, 97

W

Warnings9
Where do IP addresses come from?116
Write consistency124



0478-0353-02



**SCATTERGOOD
& JOHNSON LTD**
ELECTRICAL ENGINEERING & FLUID CONTROL DISTRIBUTORS

Est.1899

At Scattergood & Johnson Ltd, we pride ourselves on being a technical distributor to specialist industries.

Working with a range of quality product suppliers across a number of specialist markets, we are not your average 'box shifter' - we are your technical and supply chain partner.

We fully support every product we sell - for free! Our internal team and external sales engineers can answer any product or application question, no matter the complexity.

Backing up this technical ability is a range of 50,000+ products available from stock for nationwide next day delivery (same day if required!), or you can collect what you need from any of our trade counters around the UK.

Select your specialist interest below to learn more about how we can help.

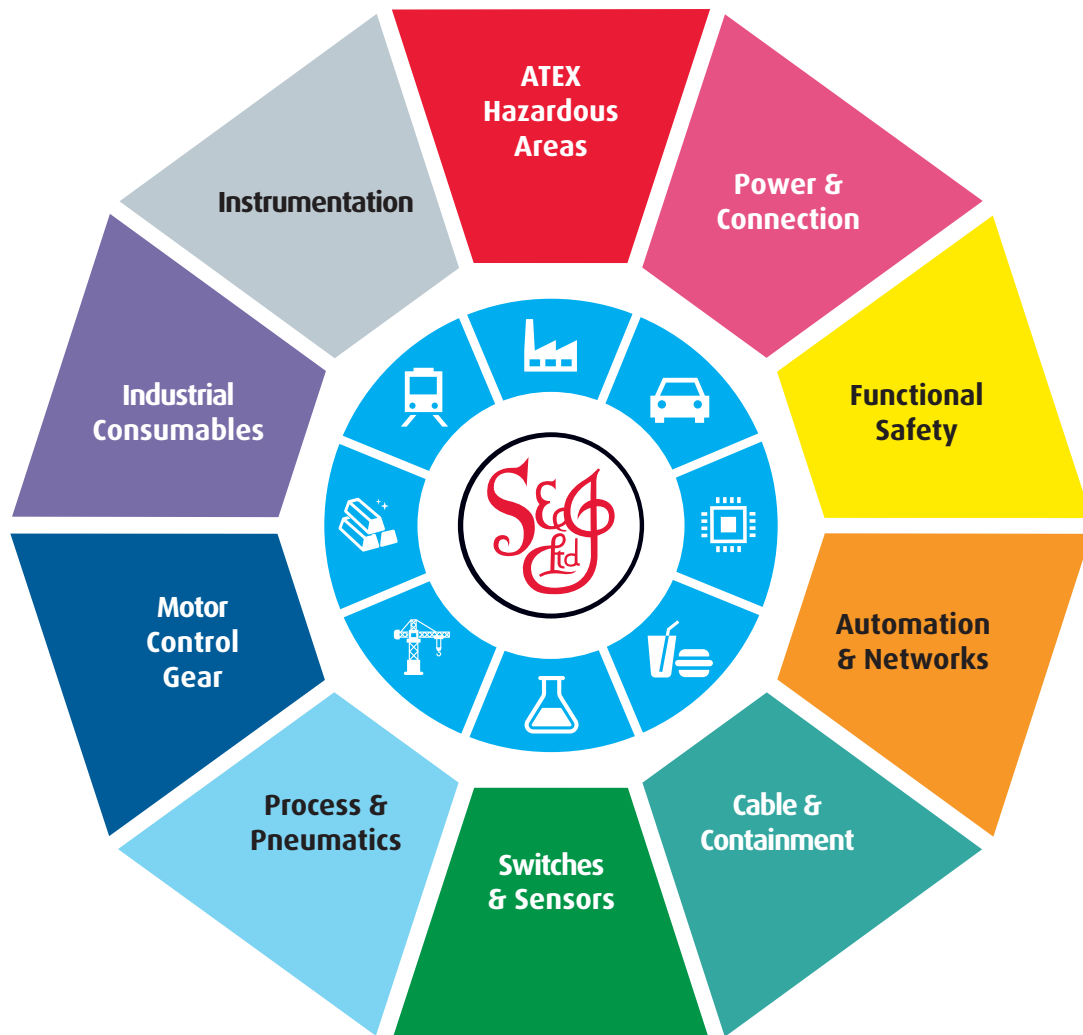

Online, In Branch and On the Road - Scattergood & Johnson Ltd, there when you need us.

www.scatts.co.uk