

Local safety enclosures

Load break switches
enclosed SIRCO (M) from 16 to 1250 A

SIRCO M polycarbonate enclosure

Front operation



General characteristics

- Equipped with a 3 pole SIRCO M.
- 1 removable neutral terminal and 1 removable earth terminal.
- Possibility of adding 1 additional pole.
- Possibility of adding 1 M-type auxiliary contact module.
- Protection IP65.

References

Enclosed switches

Rating (A)	No. of pole	Handle colour	Enclosure colour	Reference
16	3 P	Black	Grey	2215 3300
16	3 P	Red	Yellow	2215 3400
20	3 P	Black	Grey	2215 3301
20	3 P	Red	Yellow	2215 3401
25	3 P	Black	Grey	2215 3302
25	3 P	Red	Yellow	2215 3402
32	3 P	Black	Grey	2215 3303
32	3 P	Red	Yellow	2215 3403
40	3 P	Black	Grey	2215 3304
40	3 P	Red	Yellow	2215 3404
63	3 P	Black	Grey	2215 3306
63	3 P	Red	Yellow	2215 3406
80	3 P	Black	Grey	2215 3308
80	3 P	Red	Yellow	2215 3408
100	3 P	Black	Grey	2215 3309 ⁽¹⁾
100	3 P	Red	Yellow	2215 3409 ⁽¹⁾

(1) No UL.

Empty enclosures

Rating (A)	No. of pole	Handle colour	Enclosure colour	Reference
16 ... 40	3 P	Black	Grey	2215 9305
16 ... 40	3 P	Red	Yellow	2215 9405
63 ... 80	3 P	Black	Grey	2215 9309
63 ... 80	3 P	Red	Yellow	2215 9409

Dimensions

SIRCO M 16 to 40 A

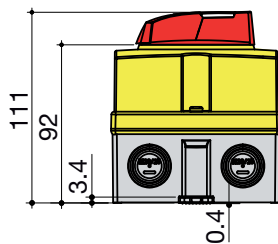
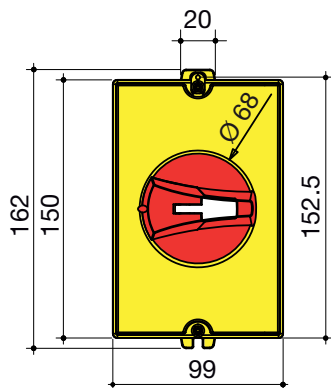

sircm_130_c_1_cat

For enclosure 162 x 99 mm

- 4 pre-drilled holes M16 (on the side).
- 4 pre-drilled holes M20 / M25 (top and bottom).
- 4 pre-drilled holes M20 (rear).

SIRCO M 63 to 100 A

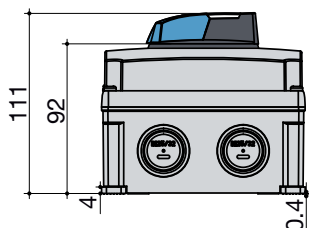
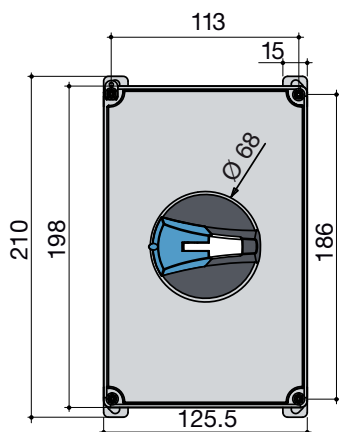

sircm_131_b_1_cat

For enclosure 210 x 125.5 mm

- 4 pre-drilled holes M16 (on the side).
- 4 pre-drilled holes M25 / M32 (top and bottom).
- 2 pre-drilled holes M25 / M32 (rear).



SCATTERGOOD & JOHNSON LTD

ELECTRICAL ENGINEERING & FLUID CONTROL DISTRIBUTORS

Est.1899

At Scattergood & Johnson Ltd, we pride ourselves on being a technical distributor to specialist industries.

Working with a range of quality product suppliers across a number of specialist markets, we are not your average 'box shifter' - we are your technical and supply chain partner.

We fully support every product we sell - for free! Our internal team and external sales engineers can answer any product or application question, no matter the complexity.

Backing up this technical ability is a range of 50,000+ products available from stock for nationwide next day delivery (same day if required!), or you can collect what you need from any of our trade counters around the UK.

Select your specialist interest below to learn more about how we can help.

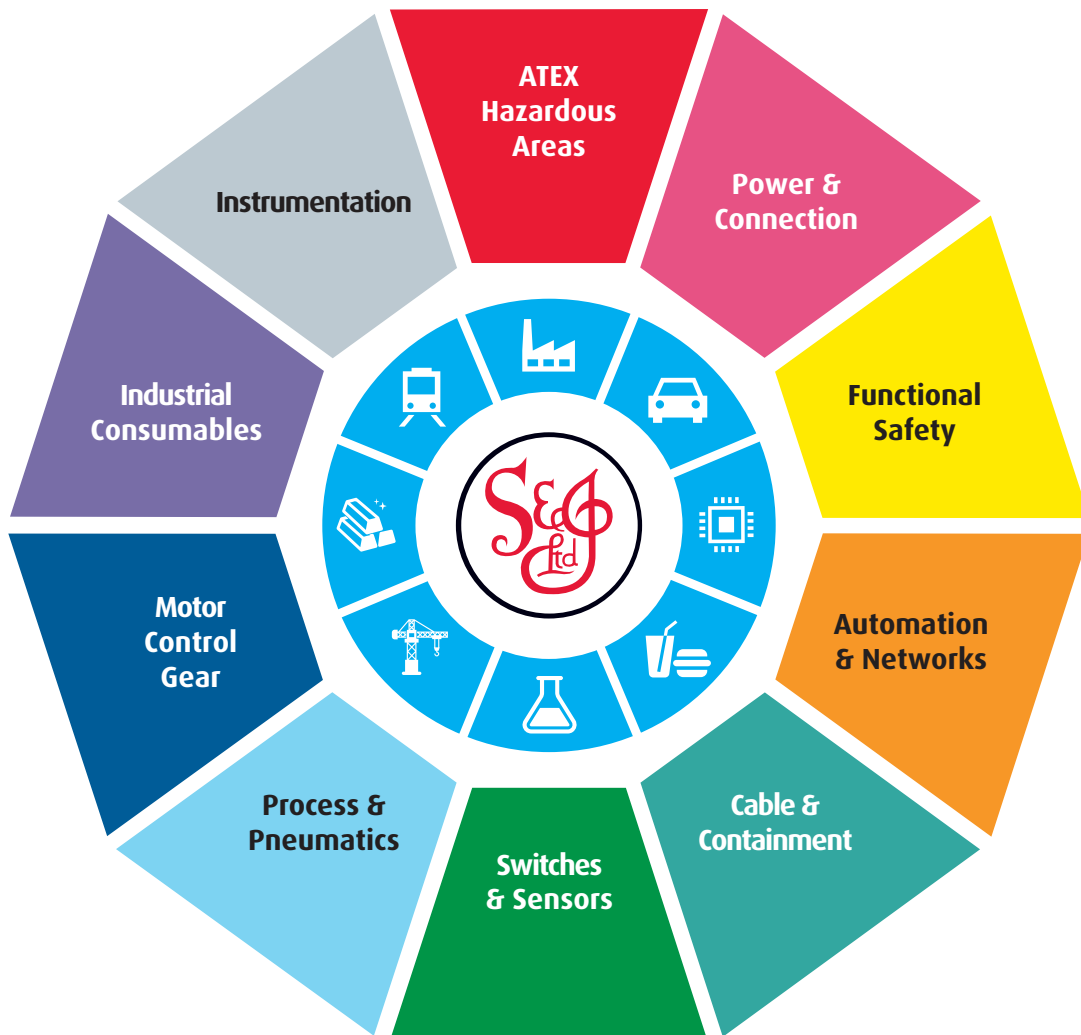

Online, In Branch and On the Road - Scattergood & Johnson Ltd, there when you need us.

www.scatts.co.uk