

●Wiring of inputs and outputs

Signal Name	Terminal Name	Description of operation	Wiring
Power supply input	A1, A2	The input terminals for power supply. Connect the power source to the A1 and A2 terminals.	Connect the power supply plus to the A1 terminal. Connect the power supply minus to the A2 terminal.
Safety input 1	T11, T12	To set Safety outputs in ON state, HIGH state signals must be input to both of Safety input 1 and Safety input 2. Otherwise Safety outputs cannot be in ON state.	1-channel Safety input 2-channel Safety input
Safety input 2	T21, T22		
Reset/Feedback input	T31, T32, T33	To set Safety outputs in ON state, ON state signal must be input to T33. Otherwise Safety outputs cannot be in ON state. To set Safety outputs in ON state, the signal input to T32 must change from OFF state to ON state, and then to OFF state. Otherwise Safety outputs cannot be in ON state.	Auto reset Manual reset
Safety output	13-14, 23-24, 33-34, 43-44	Turns ON/OFF according to the state of safety inputs, Feedback/Reset inputs. During off-delay state, safety outputs are not able to turn ON.	Keep these outputs Open when NOT used.
Off-delayed Safety output	37-38, 47-48	Off-delayed safety outputs. (See Note 1) Off-delay time is set by off-delay preset switch. When the delay time is set to zero, these outputs can be used as non-delay outputs.	Keep these outputs Open when NOT used.
Auxiliary output	X1	Outputs a signal of the same logic as Safety outputs	Keep these outputs Open when NOT used.

(1) When the inputs of G9SE-221-T□ are restored during off-delay time, G9SE-221-T□ will operate as below. Depending on the reset mode.
 - Auto reset mode: Outputs turn off after off-delay time, then immediately turns on.
 - Manual reset mode: Outputs turn off after off-delay time, then turn on when reset input is given.

●Connecting Safety Sensors and G9SE

In many cases, Safety Sensor outputs include the off-shot pulse for its self test. The following condition of test pulse is applicable as safety inputs for G9SE.
 - Off-shot pulse width of the sensor, during the ON-state : 640 μs

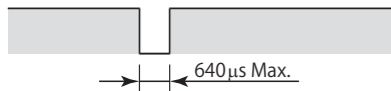

●Terminal arrangement and LED indicators

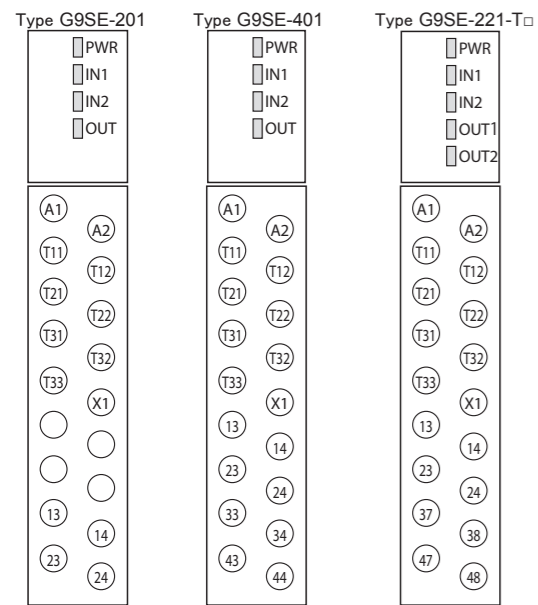

5 Examples of application

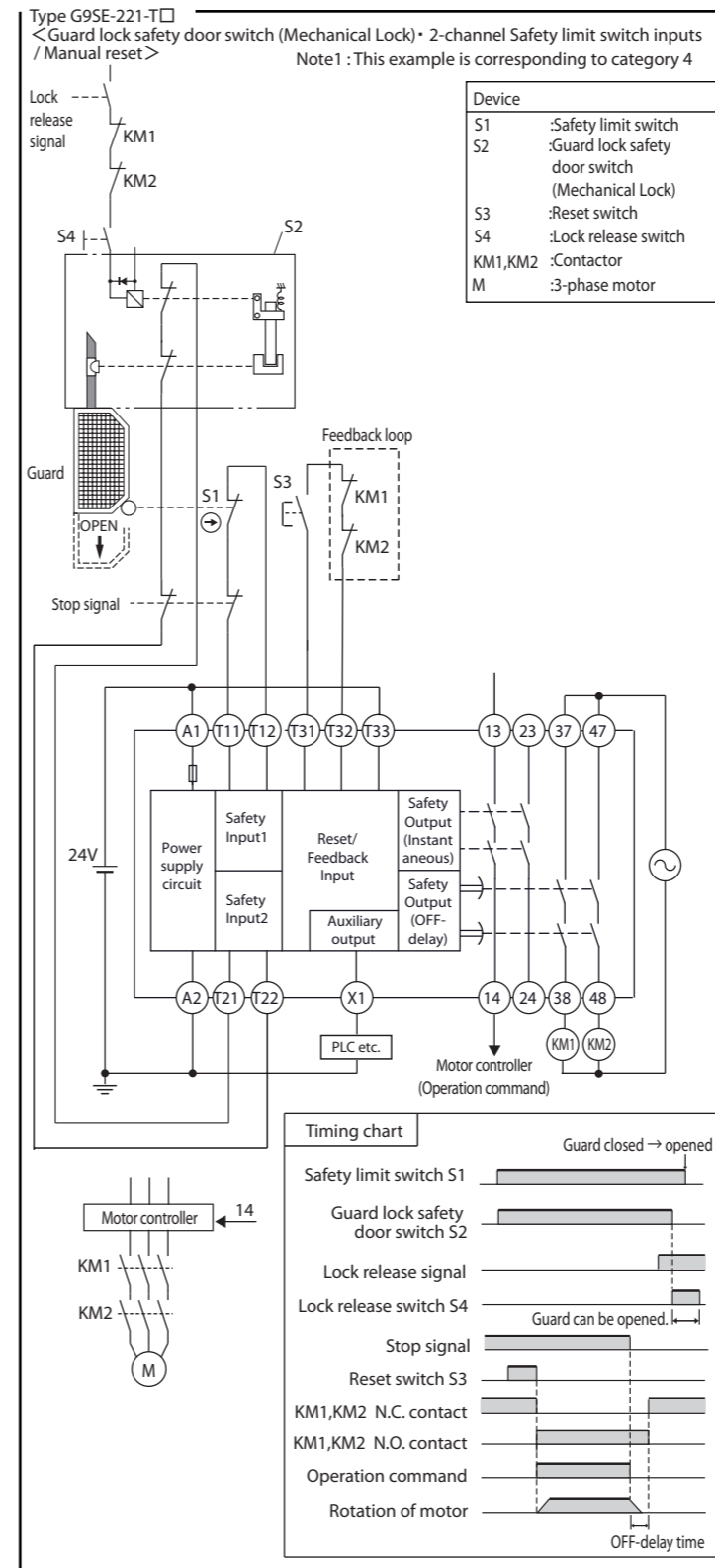
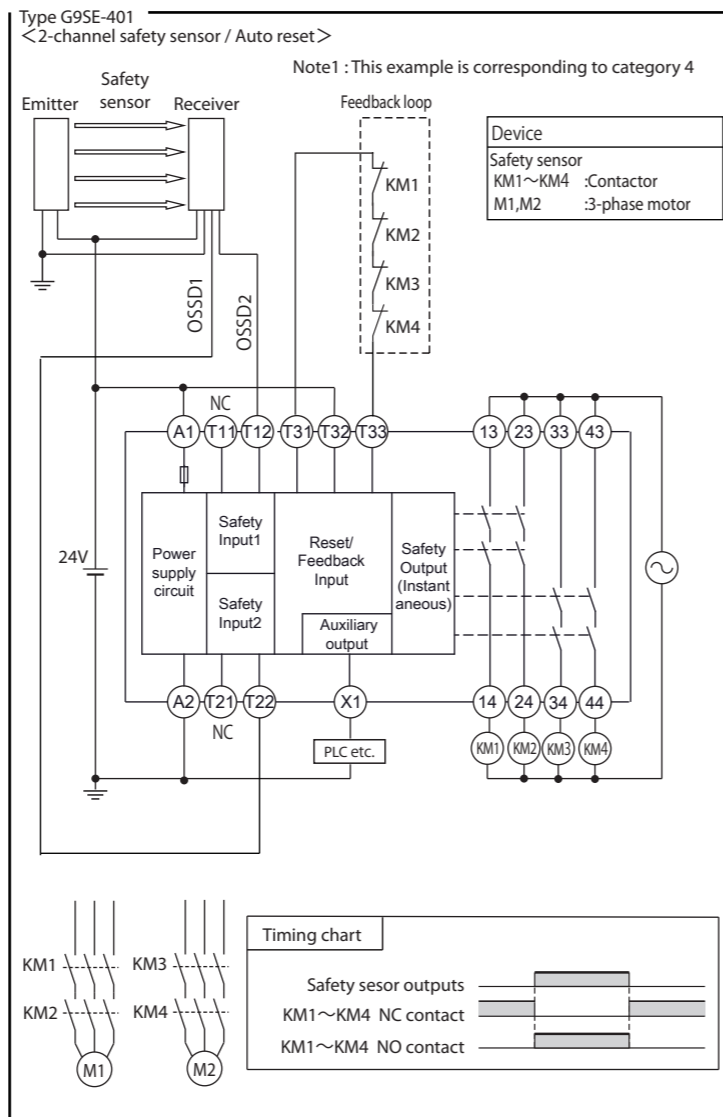
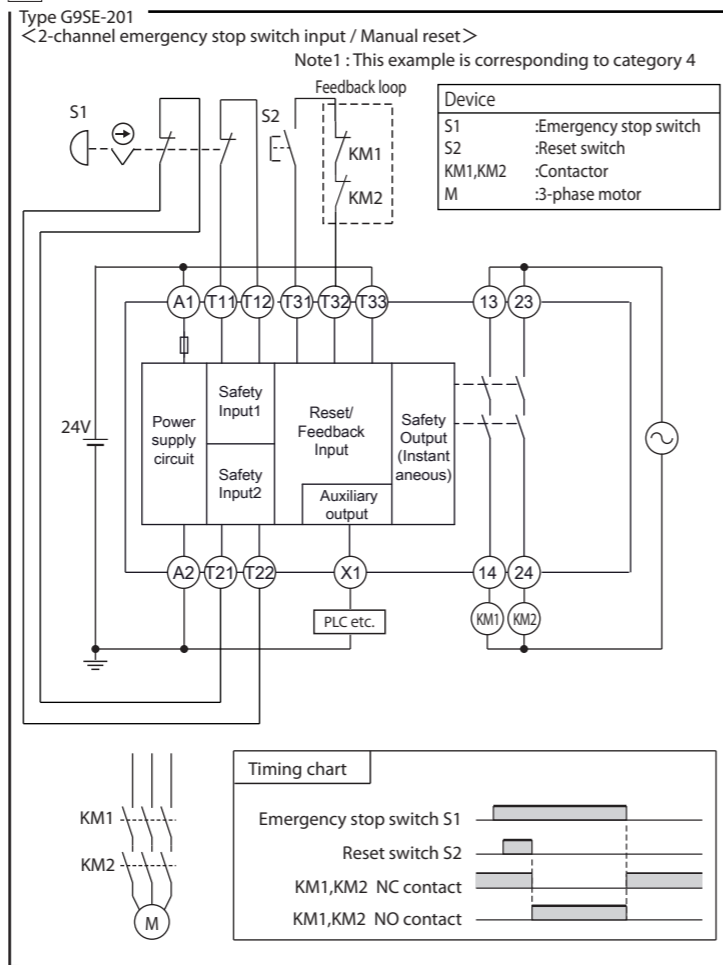

6 Performance level and safety category (EN ISO13849-1)

Type G9SE can construct the condition conforming to PL=e and category 4 requested by EN ISO13849-1 European standard. This category class is recognized and based on the circuits we made, so we would like you to conform the category class with G9SE at your application once. Category is judged by the condition of the whole control system.
 • In order to category 4 (EN ISO13849-1)
 1) Input the signals to both of the Safety inputs (T11-T12 and T21-T22)
 2) Input a signal to the Safety inputs (T11-T12 and T21-T22) through switches with Direct Opening Mechanism. When using limit switches, at least one of them must have Direct Opening Mechanism. And wiring must be done in a way that a short circuit between the wires of safety input can be excluded.
 3) When connecting Safety sensor with G9SE, use TYPE 4 safety sensor.
 4) Input the signal through a NC contact of the contactor to Feedback/Reset input (T31-T32 for manual reset or T31-T33 for auto reset).(Refer to '5.Examples of Application')
 5) Be sure to connect the negative terminal of DC power supply to ground.
 6) Use two safety outputs (e.g. 13-14 and 23-24) for the system construction.

7 Fault Detection

When G9SE detects a fault, LED indicators blink to show the information of the fault.

When PWR indicator blinks, check and take needed measures referring to the following table. And then apply supply voltage to G9SE.

PWR	LED indicator				Expected causes of the faults	Checking points and measures to take
	IN1	IN2	OUT1	OUT2		
● Blink	—	—	—	—	1) Failures involving the wiring of Safety input 1 2) Failures of the parts of the circuits of Safety input 1.	1) Check the wiring to T11 and T12. 2) Replace with a new product.
—	● Blink	—	—	—	1) Failures involving the wiring of Safety input 2 2) Failures of the parts of the circuits of Safety input 2.	1) Check the wiring to T21 and T22. 2) Replace with a new product.
● Light up	● Light up	—	—	—	1) Failures involving the wiring of Feedback/Reset input. 2) Failures of the parts of the circuits of Feedback/Reset input.	1) Check the wiring to T31, T32, and T33 2) Replace with a new product.
○ Light off	○ Light off	—	—	—	1) Failures of the parts or relays of the circuits of instantaneous Safety Output.	1) Replace with a new product.
—	—	● Blink	—	—	1) Mismatch of the two Off-delay Time Preset Switches. 2) Failures of the parts or relays of the circuits of OFF-delay Safety Output.	1) Check both of the two Off-delay Time Preset Switches. 2) Replace with a new product.
—	—	—	● Blink	—	1) Supply voltage outside the rated value.	1) Check the supply voltage to G9SE.
—	—	—	—	● The all indicators Blink	1) By excessive electro-magnetic disturbance. 2) Failures of the parts of internal circuits	1) Check the disturbance level around G9SE and its related system. 2) Replace with a new product.
—	—	—	—	○ The all indicators Light off	1) Failures of the parts of internal circuits	1) Check the disturbance level around G9SE and its related system. 2) Replace with a new product.

When indicators other than PWR indicator blink while PWR indicator lights up, check and take needed measures referring to the following table. After removing the fault, turn both safety inputs to OFF state.

PWR	LED indicator				Expected causes of the faults	Checking points and measures to take
	IN1	IN2	OUT1	OUT2		
● Light up	● Safety inputs: ON-state	● Blink	● Blink	—	1) Mismatch between Safety input 1 and Safety input 2. (OFF timing)	1) Check the wiring from safety input devices to G9SE. Or check the inputs sequence of safety input devices.
—	○ Blink	○ Blink	—	—		
—	○ Light off	○ Light off	—	—		
—	○ Light off	○ Blink	—	—		

8 Wiring

Use the following to wire to G9SE.
 - Solid wire: AWG24 to AWG16 (0.25 to 1.5 mm²)
 - Stranded wire: AWG24 to AWG16 (0.25 to 1.5 mm²)
 Strip the cover of wire no longer than 8 to 10 mm
 When using stranded wire, insulated ferrule should be used. Use below insulated ferrule.
 But do not use ferrule terminals if G9SE is used as UL Listing. Insert the strand or solid wire directly into the holes on the terminal block.
 - Insulated ferrule: AWG24 to AWG16 (0.25 to 1.5 mm²)
 - Crimp height(H): 2.0 mm max Width(W): 2.7 mm max. Conductor length: 8 to 10 mm
 When using the twin type ferrule, use equal-sized wires and preferred insulated ferrule.
 The twin type ferrule should not be above the adjoining release hole.

Recommended insulated ferrule: manufactured by Phoenix contact

Type	Wire size		
	Cross section(mm ²)	AWG	
Single	AI 0.34-8TQ	0.34	22
	AI 0.5-10WH	0.5	20
	AI 0.75-10WH	0.75	18
	AI 1-10RD	1.0	18
	AI 1.5-10BK	1.5	16
Twin	AI TWIN2x0.75-10WH	2 x 0.75	—

●How to insert solid wire and insulated ferrule
 The wire should be pushed into the terminal block straight. No need to use the driver.
 After inserting, make sure wire is fastened on to terminal block.

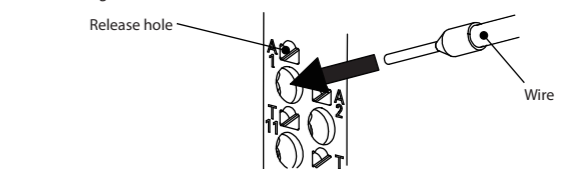

●How to release wire
 Use the following minus drive to release wire from terminal block. And When releasing wire, the power source should be disconnected first.
 1. Push the driver lightly into the taper of release hole.
 2. Pull out the wire while the driver is pushed into release hole.
 3. Pull out the driver.

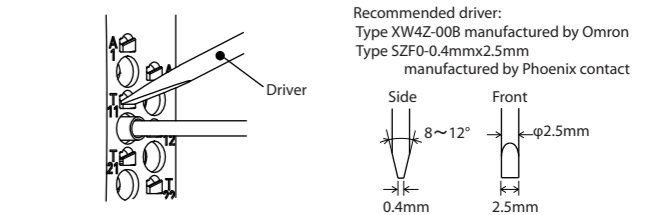

●Precautions for Correct wiring

Terminal block may be damaged.
 1. Not push the driver into the release hole straight.
 2. Not push the driver into the release hole by force of 30N and over.
 3. Not tip or twist the driver pushed into release hole.



SCATTERGOOD & JOHNSON LTD

ELECTRICAL ENGINEERING & FLUID CONTROL DISTRIBUTORS

Est.1899

At Scattergood & Johnson Ltd, we pride ourselves on being a technical distributor to specialist industries.

Working with a range of quality product suppliers across a number of specialist markets, we are not your average 'box shifter' - we are your technical and supply chain partner.

We fully support every product we sell - for free! Our internal team and external sales engineers can answer any product or application question, no matter the complexity.

Backing up this technical ability is a range of 50,000+ products available from stock for nationwide next day delivery (same day if required!), or you can collect what you need from any of our trade counters around the UK.

Select your specialist interest below to learn more about how we can help.



Online, In Branch and On the Road - Scattergood & Johnson Ltd, there when you need us.

www.scatts.co.uk