

DESIGNED FOR FLEXIBILITY

Programmable Safety Controllers



» Unmatched scalability

» Consistent programming

» One tool, one process, one setup



Scalable safety for your growing demand

Omron programmable safety controllers are designed for installations that may change and are regularly updated, therefore total scalability is essential to ensure safety, productivity and maximum efficiency at all times. The controllers can be upscaled from standalone to networked systems, and this portability protects the investment of both machine maker and end-user. Connection is exceptionally easy, and the units can be networked with PLCs and HMIs using EtherNet/IP or DeviceNet protocols. As with all Omron products, programmable safety controllers are supported with local service, worldwide.

Consistent to protect your investment

Omron programmable safety controllers can be used in a standalone application – for example on a machining centre – or on a network. In addition, the programming, configuration and installation of all units in the range are exactly the same. This reduces the learning curve when new machines are engineered or existing systems are re-engineered, as well as protecting investment in skills and training.

Full scale line-up machine automation

Modern production lines often need completely flexible architecture, either with one multi-function machine, or several machines that work together to perform multiple functions. In both cases, the functionality often needs to be changed as new processes are added and existing ones changed – and Omron programmable safety controllers can be changed easily at the same time. This ensures that high throughput and zero-defect production are maintained with no compromise on safety.



- standalone and network operation
- up to 255 function blocks
- up to 1024 safe inputs
- up to 512 safe outputs
- connectivity via DeviceNet, Ethernet/IP and USB
- minimum reaction time 15ms

One tool, one process, one set-up

Omron programmable controllers utilise the same logical processes for programming, diagnosis and maintenance, so that all systems are set up in exactly the same way, whether on a standalone machine or in a network. This simplifies configuration, as the same processes are used for every installation. This reduces machine downtime, improves efficiency and ensures security for operators, equipment and products.

Delivering local services - worldwide

Omron provides comprehensive international support based on the needs of local customers. Wherever the machine is designed, manufactured or installed, wherever you or your customer are based, you can rely on the same level of service support, engineering back-up and parts supply. We focus totally on your needs.

Scalable safety solution meeting the variety of need in your market today

Depending on the level of your safety control requirements, Omron offers the solutions in a smooth and scalable way.

For fast and flexible safety solutions, Omron' programmable safety controllers offer the efficiency and consistency needed, to protect your investment.

For a straight forward tailored safety solution to fit your applications, we offer with the G9SX-series a complete range of fully configured, pre-programmed safety controllers.



Fully programmable for seamless integration

Modern machine users look for transparent, flexible and scalable automation, whether through a standalone machine capable of handling multiple functions, or a multi-machine/multi-function production line or cell. Programmable safety controllers are vital for such applications, because they can change or grow with the installation, protecting the user's investment and supporting high throughput and zero defect production. Windows-based editors are used with logical program blocks to make changes in situ and as quickly as possible, so that lines can be up and running again in minimum time. Operators can work confidently and securely, so that maximum productivity is assured.

Simple to set-up, use and modify

When deployed on a standalone operator-controlled machine, a programmable safety controller compiles comprehensive feedback on safety status, monitoring a wide range of different inputs. These inputs can be easily changed and extended, as can the output deliveries. This also enables the machine to be seamlessly integrated into a network as necessary, providing centralised information of safety status.

- Easily installed on multi-function machines
- LED displays for feedback and advanced diagnostics
- Easily reprogrammed when machine functionality changes
- Easily integrated into DeviceNet or Ethernet/IP if necessary



Monitoring and controlling standalone machines

Machines that are manually operated – either completely or partially – have specific safety issues. Operators can work efficiently, with a full level of information and control at their fingertips.

- Easily programmed/re-programmed in situ
- Configuration on Windows-based PC using USB connection
- Seamless integration of all safety systems
- Secure operation for maximum productivity

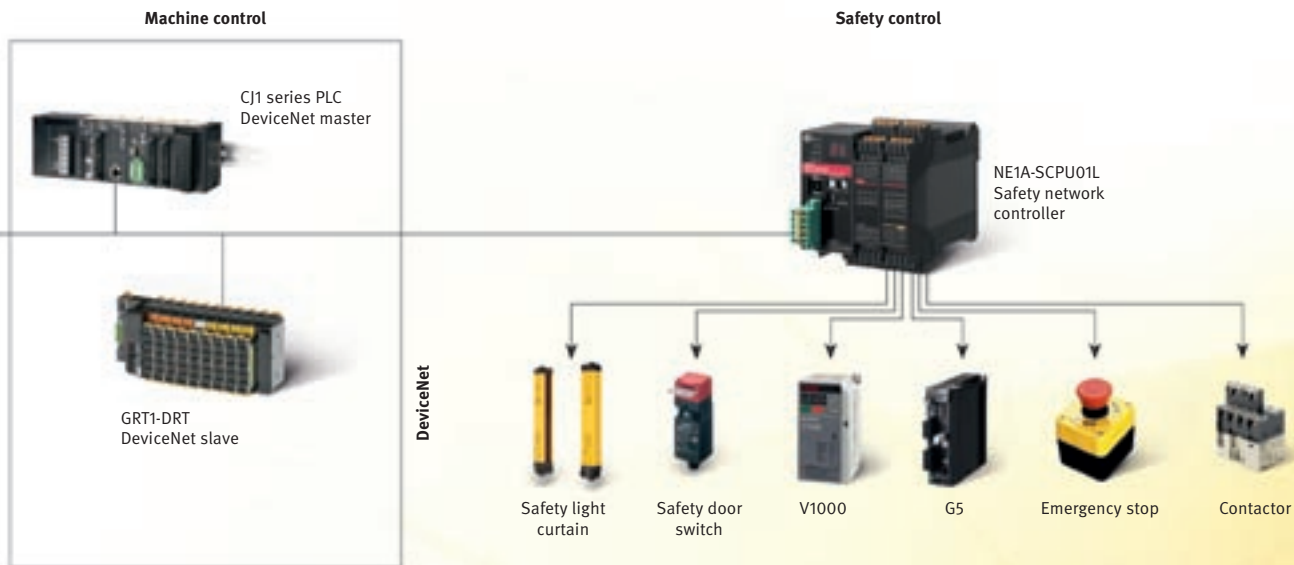

On device monitoring

Status-LEDs and Seven segment display

Status LEDs for In- and outputs

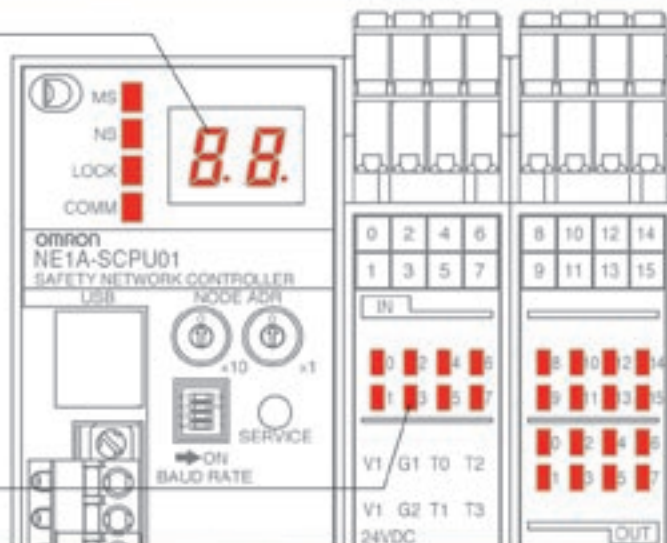

Completely scalable for modular systems

Modern production lines must be changed, modified and upgraded regularly to cope with new products and to accommodate new stations. Every time a change is made, the safety control system needs to be reconfigured at the same time: and with programmable safety controllers, this is simplicity itself. The system has up to 1024 inputs and 512 safety outputs, so it can monitor all of the safety devices on a modular production line, seamlessly integrated using the DeviceNet Safety protocol and the Ethernet/IP protocol.

Fully scalable for maximum efficiency

The beauty of the Omron programmable safety controller is its simplicity. Predefined function blocks enable easy programming/re-programming, so that adding an extra station or safety facility into a production line is handled easily. The unit will manage up to 32 DeviceNet safety slaves – more than enough for most mid-sized applications. Comprehensive and continual data is delivered on front-mounted LED displays with advanced diagnostics, so that lines can be operated at optimum rates in complete security.

- Easy to install using removable terminals
- Simple programming with predefined function blocks
- Clear LED displays for advanced diagnostics
- Simple troubleshooting and predictive maintenance
- I/O terminals for modularity and scalability



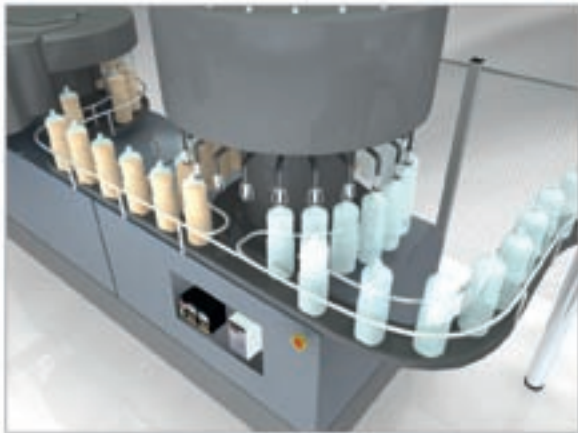

Combined Safety I/O-Module to Interface E-Stop and safe inverter for safe local shutdown.



Programmable safety controller with local safety I/O controls entire safety application.



Safe shutdown is controlled by a Safety I/O-Module, additionally monitoring safety door switches.

Machine control

Safety control

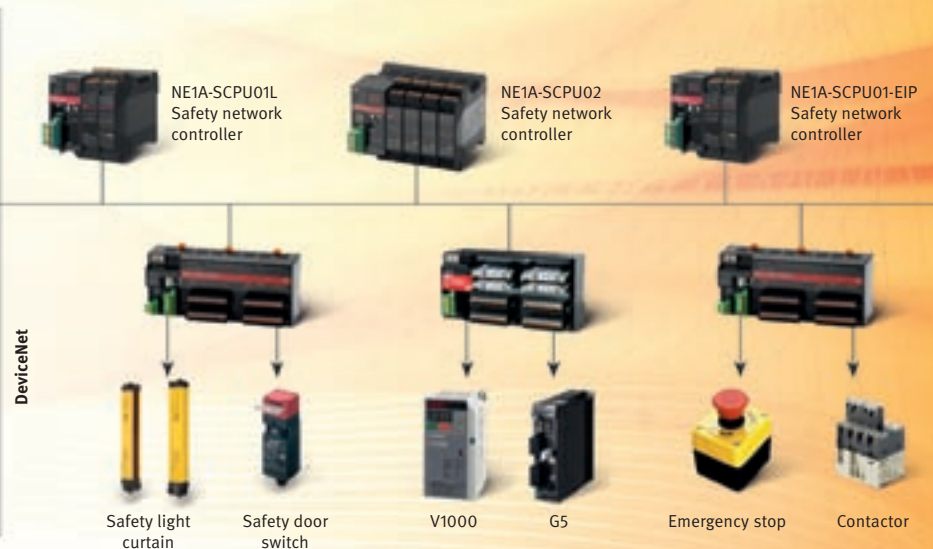
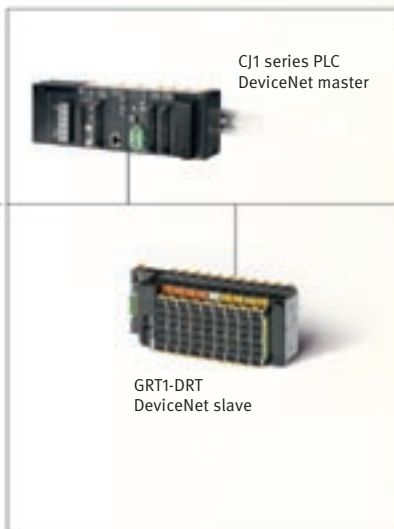

Simple step-by-step configuration

Complex production lines use a wide array of safety and control systems, all of which need to be continually monitored to avoid quality and security issues. Omron programmable safety controllers provide the high level of control required for this kind of installation. As with all Omron safety systems, programmable controllers can be fully integrated with other devices in the range, and the use of the same programming software for all configurations ensures that design, engineering and installation can be achieved at minimum cost, but at maximum efficiency.

Logical, predictive, safe

Setting-up a programmable safety controller into a DeviceNet system could not be simpler. The device is configured (or reconfigured) using logical, step-by-step programming that simulates system-operation on the PC screen. This ensures that all devices in the line are fully controlled, and that data is fed back to the controller and HMI for maintenance and monitoring. Diagnosis of system activity is enabled by clear and easily understood interfaces. The result is effective troubleshooting, predicted downtime for routine maintenance and increased productivity.

- Configuration using standard PC running Windows
- Predefined logical function blocks set-up using built-in logic editor
- Online diagnosis through integrated interfaces
- Predictive maintenance and troubleshooting information on HMI
- Logic simulator to support engineering and test



Logical, step-by-step set-up



STEP 1 The controller hardware is set up

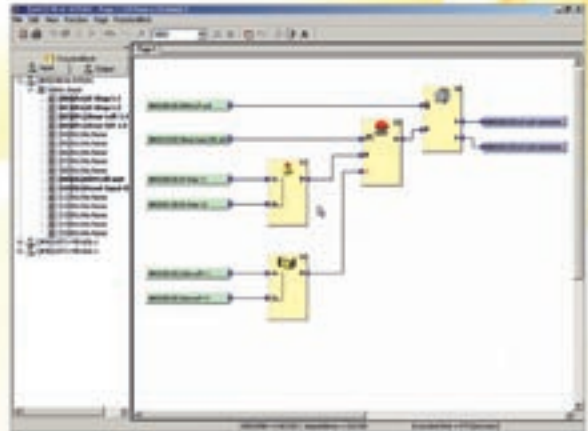

STEP 2 The application program is installed and configured, using pre-defined function blocks in the Windows-based logic editor

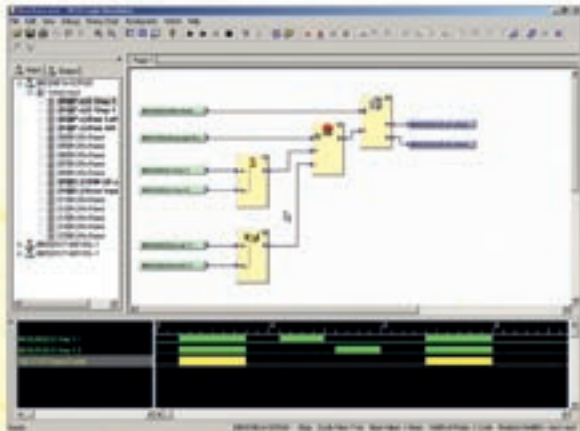

STEP 3 The application program is tested with the logic simulator

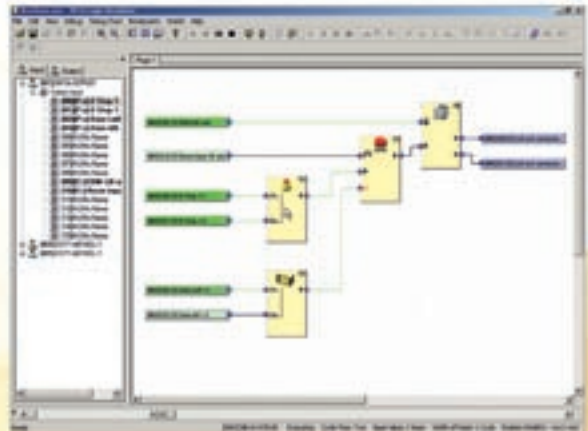

STEP 4 Using a USB cable or network connection, the application program is downloaded,

STEP 5 The application program is validated and verified for safety and security, and password protected to prevent unauthorised manipulation

Nothing could be simpler, nothing could be more straightforward.



Standalone Controller

Safety controllers

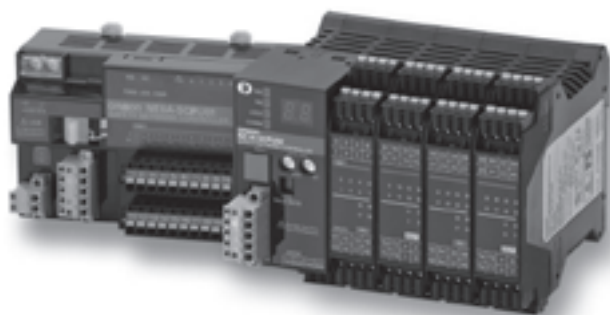

NE0A and NE1A-L

The NE0A and NE1A hosts the safety application program. All local safety-based in- and outputs are monitored and controlled by the NE0A and the NE1A-L. It can be seamlessly integrated in a standard DeviceNet system.

- Removable cage-clamp terminals for easy installation
- Predefined and certified function blocks for easy programming
- LED display and status LEDs for advanced diagnostics
- System status on DeviceNet for easy troubleshooting and predictive maintenance
- Portability of configuration to DeviceNet Safety Bus Systems for maximum scalability

Ordering information

Appearance	Appearance description	Order code
Standalone Safety Controller	12 PNP inputs 6 PNP outputs 2 test outputs removable cage clamp terminals	NE0A-SCPU01
	16 PNP inputs 8 PNP outputs 4 test outputs 254 function block programming removable cage clamp terminals	NE1A-SCPU01L
	40 PNP inputs 8 PNP outputs 8 test outputs 254 function block programming removable cage clamp terminals	NE1A-SCPU02L

Software

Appearance	Appearance description	Order code
Safety network configurator	Installation disk (CD-ROM) IBM PC/AT compatible Windows 2000 or XP (English version)	WS02-CFSC1-E

Stand-alone programmable controller

Programmable safety circuits

The standalone safety controller uses predefined logical function blocks to set up the safety system. Modifications of the safety system in the life cycle of a machine are done without tedious wiring.

Specifications

General specifications

DeviceNet communications power supply voltage	11 to 25 VDC (supplied from communications connector)	
Unit power supply voltage	20.4 to 26.4 VDC	
I/O power supply voltage	(24 VDC -15% +10%)	
Consumption current	Communications power supply	24 VDC, 15 mA
	Internal circuit power supply	24 VDC, 230 mA
Mounting method	35-mm DIN track	
Ambient operating temperature	-10°C +55°C	
Ambient storage temperature	-40°C +70°C	
Degree of protection	IP20 (IEC 60529)	

Safety input specifications

Input type	Sinking inputs (PNP)
ON voltage	11 VDC min. between each input terminal and G1
OFF voltage	5 VDC max. between each input terminal and G1
OFF current	1 mA max.
Input current	4.5 mA

Safety output specifications

Output type	Sourcing outputs (PNP)
Rated output current	0.5 A max. per output
Residual voltage	1.2 V max. between each output terminal and V2

Test output specifications

Output type	Sourcing outputs (PNP)
Rated output current	0.7 A max. per output (see note.)
Residual voltage	1.2 V max. between each output terminal and V1

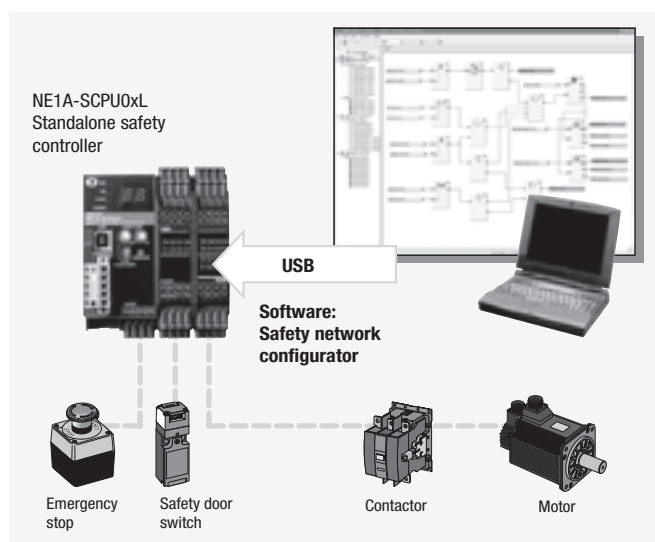



Safety network controller NE1A

The NE1A hosts the safety application program. All local and DeviceNet safety-based in- and outputs are monitored and controlled by the NE1A. It manages up to 32 DeviceNet safety slaves and can be seamlessly integrated in a standard DeviceNet system.

- Removable cage-clamp terminals for easy installation
- Predefined and certified function blocks for easy programming
- LED display and status LEDs for advanced diagnostics
- System status on DeviceNet for easy troubleshooting and predictive maintenance
- Easy scalability through the addition of DeviceNet safety devices

Ordering information

Appearance	Appearance description	Interface	Order code
Safety network controller	16 PNP inputs 8 PNP outputs 4 test outputs 254 function block programming removable cage clamp terminals	USB and DeviceNet Safety	NE1A-SCPU01-V1
		Ethernet/IP and DeviceNet Safety	NE1A-SCPU01-EIP
	40 PNP inputs 8 PNP outputs 8 test outputs 254 function block programming removable cage clamp terminals	USB and DeviceNet Safety	NE1A-SCPU02
		Ethernet/IP and DeviceNet Safety	NE1A-SCPU02-EIP

Software

Appearance	Appearance description	Order code
Safety network configurator	Installation disk (CD-ROM) IBM PC/AT compatible Windows 2000 or XP (English version)	WS02-CFSC1-E

Accessories

Appearance	Appearance description	Order code
Network router	Ethernet/IP - DeviceNet router	NE1A-EDR01
Programming console	CF-Card slot to store configuration USB-Interface for maintenance Touchscreen for easy troubleshooting	NE1A-HDY

Specifications

General specifications

DeviceNet communications power supply voltage	11 to 25 VDC (supplied from communications connector)	
Unit power supply voltage	20.4 to 26.4 VDC (24 VDC -15% +10%)	
I/O power supply voltage		
Consumption current	Communications power supply	24 VDC, 15 mA
	Internal circuit power supply	24 VDC, 230 mA
Mounting method	35-mm DIN track	
Ambient operating temperature	-10°C +55°C	
Ambient storage temperature	-40°C +70°C	
Degree of protection	IP20 (IEC 60529)	

Safety input specifications

Input type	Sinking inputs (PNP)
ON voltage	11 VDC min. between each input terminal and G1
OFF voltage	5 VDC max. between each input terminal and G1
OFF current	1 mA max.
Input current	4.5 mA

Safety output specifications

Output type	Sourcing outputs (PNP)
Rated output current	0.5 A max. per output
Residual voltage	1.2 V max. between each output terminal and V2

Test output specifications

Output type	Sourcing outputs (PNP)
Rated output current	0.7 A max. per output (see note.)
Residual voltage	1.2 V max. between each output terminal and V1

DeviceNet safety I/O terminal block family

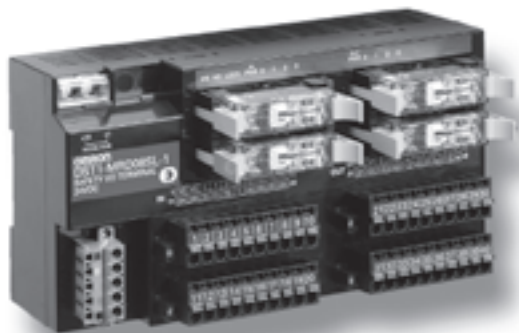

- Removable cage clamp terminals for easy installation
- up to 12 Inputs for safety signals
- 4 test pulse outputs to ensure crosstalk and short circuit detection
- up to 8 safety outputs (solid state or relay)
- Status LEDs for advanced diagnostics
- Mixed mode operation (safety and standard) for all in- and outputs

Ordering information

Safety network

Expand safety I/O through networks

Safety components distributed over many different installation locations required long and complicated wiring. Replacing the wiring with a network between safety components greatly improves productivity.

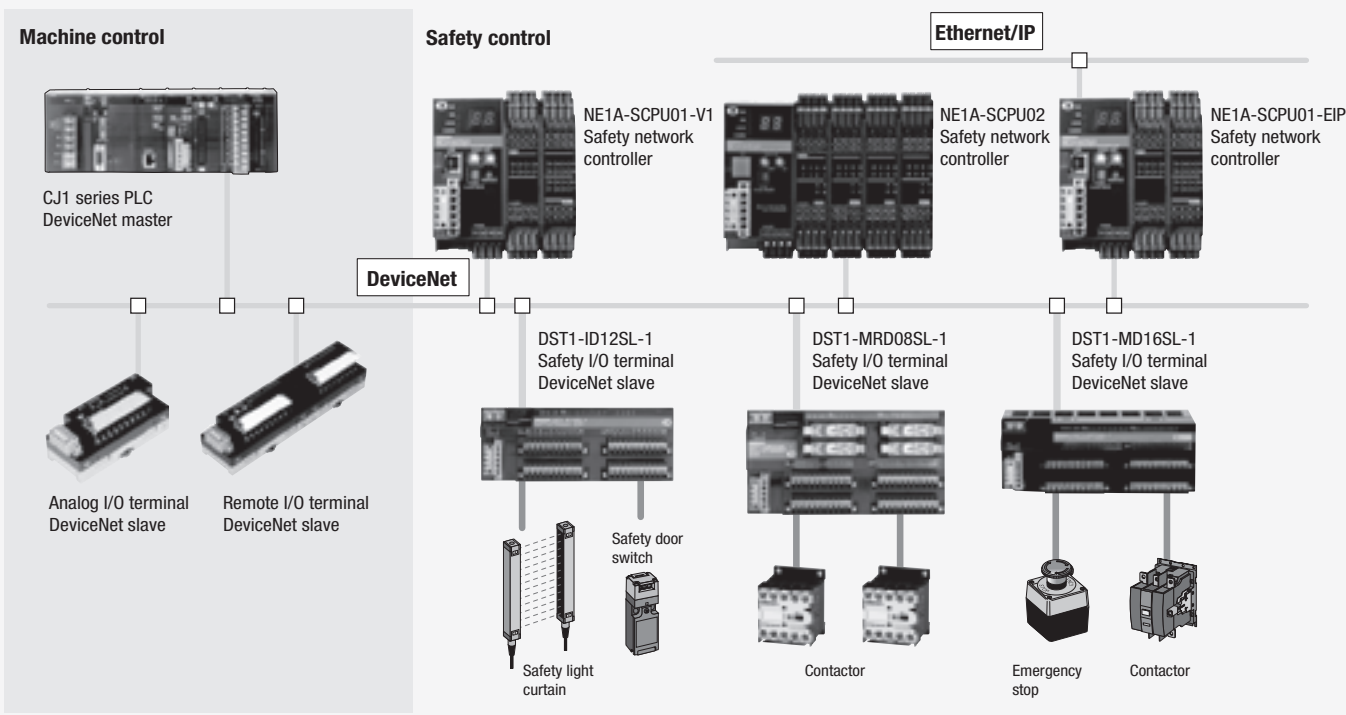

Appearance	Appearance description	Order code
Input terminal	12 PNP inputs 4 Test outputs Removable cage clamp terminals	DST1-ID12SL-1
Mixed I/O terminal	8 PNP inputs 8 PNP outputs 4 Test outputs Removable cage clamp terminals	DST1-MD16SL-1
Mixed I/O terminal	4 PNP inputs 4 relay outputs (4×2-single pole) 4 Test outputs Removable cage clamp terminals	DST1-MRD08SL-1

DST1-ID/-MD/-MRD

Safety controllers

Specifications

General specifications

DeviceNet communications power supply voltage	11 to 25 VDC (supplied from communications connector)
Unit power supply voltage	20.4 to 26.4 VDC (-15% +10%)
I/O power supply voltage	
Consumption current	Communications power supply DST1-ID12SL-1/MD16SL-1: 100 mA DST1-MRD08SL-1: 110 mA
Mounting method	35-mm DIN track
Ambient operating temperature	-10°C +55°C
Ambient storage temperature	-40°C +70°C
Degree of protection	IP20 (IEC 60529)
Weight	DST1-ID12SL-1/MD16SL-1: 420 g DST1-MRD08SL-1: 600 g

Safety output specifications

Output type	Sourcing outputs (PNP)
Rated output current	0.5 A max. per output
Residual voltage	1.2 V max. between each output terminal and V1

Test output specifications

Output type	Sourcing outputs (PNP)
Rated output current	0.7 A max. per point
Residual voltage	1.2 V max. between each output terminal and V0

Safety output specifications for relay outputs

Relays	G7SA-2A2B, EN 50205 class A
Minimum applicable load	1 mA at 5 VDC
Rated load for a resistive load	240 VAC: 2 A, 30 VDC: 2 A
Rated load for an inductive load	2 A at 240 VAC (cosφ= 0.3), 1 A at 24 VDC
Mechanical life expectancy	5,000,000 operations min. (switching frequency of 7,200 operations/h)
Electrical life expectancy	100,000 operations min. (at rated load and switching frequency of 1,800 operations/h)

Safety input specifications

Input type	Sinking inputs (PNP)
ON voltage	11 VDC min. between each input terminal and G1
OFF voltage	5 VDC max. between each input terminal and G1
OFF current	1 mA max.
Input current	6 mA

Safety I/O terminals

DST1-ID12SL-1

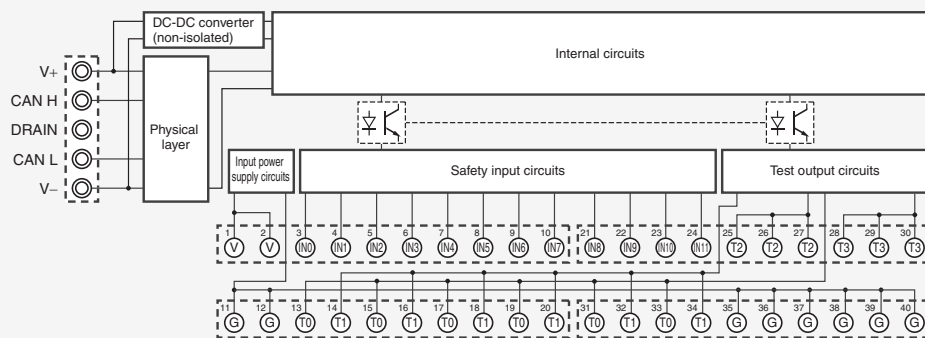

DST1-MD16SL-1

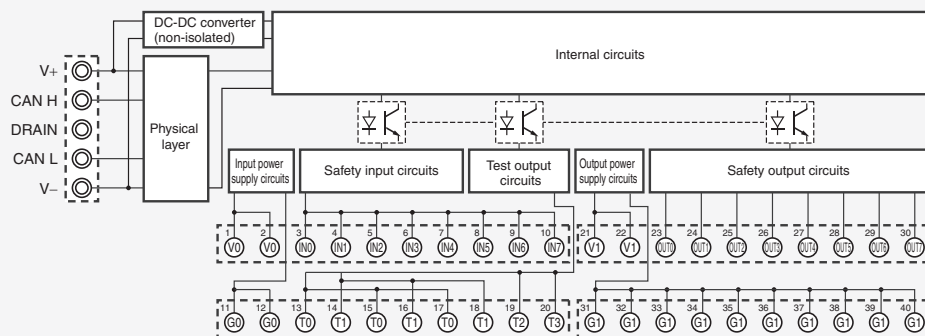

DST1-MRD08SL-1

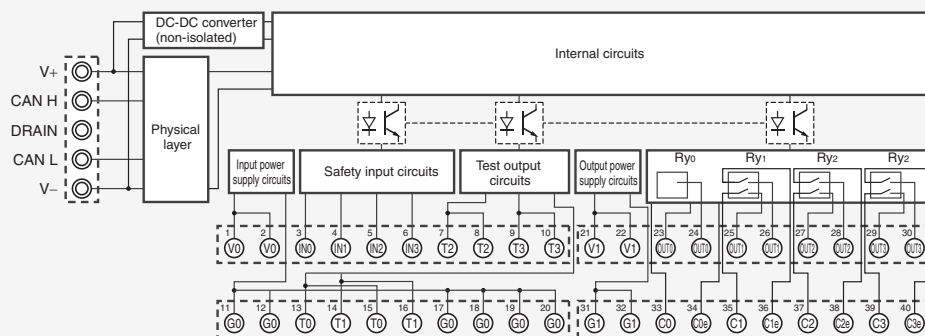



OMRON EUROPE B.V. Wegalaan 67-69, NL-2132 JD, Hoofddorp, The Netherlands. Tel: +31 (0) 23 568 13 00 Fax: +31 (0) 23 568 13 88 www.industrial.omron.eu

Austria

Tel: +43 (0) 2236 377 800
www.industrial.omron.at

Belgium

Tel: +32 (0) 2 466 24 80
www.industrial.omron.be

Czech Republic

Tel: +420 234 602 602
www.industrial.omron.cz

Denmark

Tel: +45 43 44 00 11
www.industrial.omron.dk

Finland

Tel: +358 (0) 207 464 200
www.industrial.omron.fi

France

Tel: +33 (0) 1 56 63 70 00
www.industrial.omron.fr

Germany

Tel: +49 (0) 2173 680 00
www.industrial.omron.de

Hungary

Tel: +36 1 399 30 50
www.industrial.omron.hu

Italy

Tel: +39 02 326 81
www.industrial.omron.it

Netherlands

Tel: +31 (0) 23 568 11 00
www.industrial.omron.nl

Norway

Tel: +47 (0) 22 65 75 00
www.industrial.omron.no

Poland

Tel: +48 (0) 22 645 78 60
www.industrial.omron.pl

Portugal

Tel: +351 21 942 94 00
www.industrial.omron.pt

Russia

Tel: +7 495 648 94 50
www.industrial.omron.ru

South Africa

Tel: +27 (0)11 608 3041
www.industrial.omron.co.za

Spain

Tel: +34 913 777 900
www.industrial.omron.es

Sweden

Tel: +46 (0) 8 632 35 00
www.industrial.omron.se

Switzerland

Tel: +41 (0) 41 748 13 13
www.industrial.omron.ch

Turkey

Tel: +90 216 474 00 40
www.industrial.omron.com.tr

United Kingdom

Tel: +44 (0) 870 752 08 61
www.industrial.omron.co.uk

More Omron representatives

www.industrial.omron.eu

Automation Systems

- Programmable logic controllers (PLC) • Human machine interfaces (HMI) • Remote I/O
- Industrial PC's • Software

Motion & Drives

- Motion controllers • Servo systems • Inverters

Control Components

- Temperature controllers • Power supplies • Timers • Counters • Programmable relays
- Digital panel indicators • Electromechanical relays • Monitoring products • Solid-state relays
- Limit switches • Pushbutton switches • Low voltage switch gear

Sensing & Safety

- Photoelectric sensors • Inductive sensors • Capacitive & pressure sensors
- Cable connectors • Displacement & width-measuring sensors • Vision systems
- Safety networks • Safety sensors • Safety units/relay units • Safety door/guard lock switches



SCATTERGOOD & JOHNSON LTD

ELECTRICAL ENGINEERING & FLUID CONTROL DISTRIBUTORS

Est.1899

At Scattergood & Johnson Ltd, we pride ourselves on being a technical distributor to specialist industries.

Working with a range of quality product suppliers across a number of specialist markets, we are not your average 'box shifter' - we are your technical and supply chain partner.

We fully support every product we sell - for free! Our internal team and external sales engineers can answer any product or application question, no matter the complexity.

Backing up this technical ability is a range of 50,000+ products available from stock for nationwide next day delivery (same day if required!), or you can collect what you need from any of our trade counters around the UK.

Select your specialist interest below to learn more about how we can help.



Online, In Branch and On the Road - Scattergood & Johnson Ltd, there when you need us.

www.scatts.co.uk