



Built-in Amplifier Photoelectric Sensor

E3S-A

Ordering Information

E3S-A General-purpose Sensors

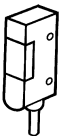
Connections	Appearance	Sensing method	Sensing distance	Operating modes	Output / timer functions	Model	
						NPN output	PNP output
Prewired		Through-beam	7 m	Light-ON Dark-ON (selectable)	---	E3S-AT11	E3S-AT31
					With timer and self-diagnostic functions	E3S-AT21	E3S-AT41
		Retroreflective	0.1 to 2 m (polarized)		---	E3S-AR11	E3S-AR31
					With timer and self-diagnostic functions	E3S-AR21	E3S-AR41
		Diffuse reflective	10 cm (light source: infra-red)		---	E3S-AD13	E3S-AD33
					With timer and self-diagnostic functions	E3S-AD23	E3S-AD43
			20 cm		---	E3S-AD11	E3S-AD31
					With timer and self-diagnostic functions	E3S-AD21	E3S-AD41
			70 cm (light source: infra-red)		---	E3S-AD12	E3S-AD32
					With timer and self-diagnostic functions	E3S-AD22	E3S-AD42

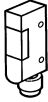



Connections	Appearance	Sensing method	Sensing distance	Operating modes	Output / timer functions	Model		
						NPN output	PNP output	
Prewired	Vertical 	Through-beam	7 m	Light-ON Dark-ON (selectable)	---	E3S-AT61	E3S-AT81	
			Retroreflective		0.1 to 2 m (polarized)	With timer and self-diagnostic functions	E3S-AT71	E3S-AT91
					Diffuse reflective	10 cm (light source: infra-red)	---	E3S-AR61
		20 cm	With timer and self-diagnostic functions				E3S-AR71	E3S-AR91
		70 cm (light source: infra-red)	---			E3S-AD63	E3S-AD83	
			With timer and self-diagnostic functions		E3S-AD73	E3S-AD93		
		---	E3S-AD61		E3S-AD81			
		With timer and self-diagnostic functions	E3S-AD71		E3S-AD91			
		---	E3S-AD62		E3S-AD82			
		With timer and self-diagnostic functions	E3S-AD72		E3S-AD92			
Connector	Horizontal 	Through-beam	7 m	---	---	E3S-AT16	E3S-AT36	
			Retroreflective			0.1 to 2 m (polarized)	E3S-AR16	E3S-AR36
		Diffuse reflective				10 cm (light source: infra-red)	E3S-AD18	E3S-AD38
			20 cm				E3S-AD16	E3S-AD36
			70 cm (light source: infra-red)			E3S-AD17	E3S-AD37	
		Vertical 	Through-beam			7 m	---	---
	Retroreflective				0.1 to 2 m (polarized)	E3S-AR66		
			Diffuse reflective		10 cm (light source: infra-red)	E3S-AD68		
	20 cm					E3S-AD66		
	70 cm (light source: infra-red)				E3S-AD67	E3S-AD87		

Accessories (Order Separately)

[E3S-A General-purpose Sensor Accessories](#)

Name	Model	Remarks
Slit for Through-beam Sensor	E39-S46	2 mm, 1 mm, and 0.5 mm slits are sold in pairs, one each for the receiver and emitter of a through-beam model
Mounting Bracket for Vertical Sensor	E39-L59	Purchase two brackets for each through-beam model
	E39-L81	
Filter for Mutual Interference Prevention (for Through-beam Sensor)	E39-E6	4 filters are sold together for two through-beam models (2 filters each for the emitters and receivers)
Reflector for Optical Axis Adjustment (for Through-beam Sensor)	E39-R5	One only

Plugs (for Sensors with Connector Terminals)

Cord	Appearance		Cord length	Model
Standard	Straight (3 conductor)		2 m	XS2F-D421-DC0-A
			5 m	XS2F-D421-GC0-A
	L-shape (3 conductor)		2 m	XS2F-D422-DC0-A
			5 m	XS2F-D422-GC0-A
Robot (vibration-proof)	Straight (4 conductor)		2 m	XS2F-D421-D80-R
			5 m	XS2F-D421-G80-R
	L-shape (4 conductor)		2 m	XS2F-D422-D80-R
			5 m	XS2F-D422-G80-R

Reflectors

Name	Model	Remarks
Mini-reflector	E39-R4	One
Small Reflector	E39-R3	One
Reflector Tape	E39-RS1, RS2, RS3	One (sealed type)

Specifications

Without self-diagnostic functions

Sensing method		Through-beam, Retro-reflective (polarized)	Diffuse reflective: 10 cm	Diffuse reflective: 20 cm	Diffuse reflective: 70 cm
Model	NPN output	E3S-AT11, -AR11 E3S-AT16, -AR16 E3S-AT61, -AR61 E3S-AT66, -AR66	E3S-AD13 E3S-AD63 E3S-AD18 E3S-AD68	E3S-AD11 E3S-AD16 E3S-AD61 E3S-AD66	E3S-AD12 E3S-AD17 E3S-AD62 E3S-AD67
	PNP output	E3S-AT31, -AR31 E3S-AT36, -AR36 E3S-AT81, -AR81 E3S-AT86, -AR86	E3S-AD33 E3S-AD83 E3S-AD38 E3S-AD88	E3S-AD31 E3S-AD36 E3S-AD81 E3S-AD86	E3S-AD32 E3S-AD37 E3S-AD82 E3S-AD87
Wavelength of LED light source		700 nm (red)	880 nm (infrared)	700 nm (red)	880 nm (infrared)
Sensitivity adjustment		Two-turn (endless) sensitivity adjustor with indicator			
Self-diagnostic functions		---			
Timer		---			
Turbo function		---			
Method of connection		Prewired / connector			
Weight		Prewired type: 60 g; connector type: 11 g			
Operation mode		Dark-ON or Light-ON (switchable)			
Output		Open collector current output (NPN or PNP)			
Circuit protection		Load short-circuit protection, reverse connection protection, mutual interference prevention (except for through-beam models)			
Indicators		Light indicator (red) and stability indicator (green); emittion indicator (red) for the emitter of through-beam models			
Materials		Case: Polybutylene terephthalate Lens: Denaturated polyallalate Mounting bracket: Stainless steel (SUS304)			
Attachments		Mounting bracket, sensitivity adjustor knob, screws, sensitivity adjustor cover, close-mounting plate (only for Sensors with connector terminals) and reflector (E39-R1: only for retroreflective Sensors)			

With self-diagnostic functions

Sensing method		Through-beam, Retroreflective (polarized)	Diffuse reflective: 10 cm	Diffuse reflective: 20 cm	Diffuse reflective: 70 cm
Model	NPN output	E3S-AT21 E3S-AR21 E3S-AT71 E3S-AR71	E3S-AD23 E3S-AD73	E3S-AD21 E3S-AD71	E3S-AD22 E3S-AD72
	PNP output	E3S-AT41 E3S-AR41 E3S-AT91 E3S-AR91	E3S-AD43 E3S-AD93	E3S-AD41 E3S-AD91	E3S-AD42 E3S-AD92
Wavelength of LED light source		700 nm (red)	880 nm (infrared)	700 nm (red)	880 nm (infrared)
Sensitivity adjustment		Two-turn (endless) sensitivity adjustor with indicator			
Self-diagnostic functions		Self-diagnostic output, External diagnostic input	Self-diagnostic output		
Timer		0 to 100 ms OFF-delay variable adjustor			
Turbo function		Yes (with turbo switch)			---
Method of connection		Prewired			
Weight		60 g			
Operation mode		Dark-ON or Light-ON (switchable)			
Output		Open collector current output (NPN or PNP)			
Circuit protection		Load short-circuit protection, reverse connection protection, mutual interference prevention (except for through-beam models) functions			
Indicators		Light indicator (red) and stability indicator (green); emission indicator (red) for the emitter of the through-beam model			
Materials		Case:	Polybutylene terephthalate		
		Lens:	Denaturated polyallalate		
		Mounting bracket:	Stainless steel (SUS304)		
Attachments		Mounting bracket, sensitivity adjustor knob, screws, sensitivity adjustor cover, close-mounting plate (only for Sensors with connector terminals) and reflector (E39-R1: only for retroreflective Sensors)			

Ratings / Characteristics

Item		Through-beam	Retroreflective	Diffuse reflective		
		E3S-AT11, 16, 21, 31, 36, 41, 61, 66, 71, 81, 86, 91	E3S-AR11, 16, 21, 31, 36, 41, 61, 66, 71, 81, 86, 91	E3S-AD23, 43, 73, 93	E3S-AD13, 18, 33, 38, 63, 68, 83, 88	E3S-AD11, 16, 21, 31, 36, 41, 61, 66, 71, 81, 86, 91
Power supply voltage		10 to 30 V DC, ripple: 10 % max.				
Current consumption		40 mA max. (emitter and receiver) plus approx. 15 mA with turbo function	30 mA max. plus approx. 15 mA with turbo function	35 mA max.	30 mA max. plus approx. 15 mA with turbo function	35 mA max.
Rated sensing distance	White mat paper	0 to 7 m	0.1 to 2 m	0.1 to 10 cm	0.1 to 20 cm	0 to 70 cm
	Black mat paper	0 to 7 m	0.1 to 2 m	0.3 to 2.5 cm	0.5 to 20 cm	0.15 to 33 cm
Standard sensing object (white mat paper)		7 mm min.	30 mm min.	10 x 10 cm		20 x 20 cm
Variation in sensing distance		---		30 % / -0 % max.		
Hysteresis		---		20 % max.	10 % max.	20 % max.
Sensing distance with attachment		E39-E6: 2.4 m 2-mm slit: 2.5 m 1-mm slit: 1.1 m 0.5-mm slit: 0.5 m	E39-R3: 10 to 130 cm E39-R4: 7 to 60 cm E39-RSA: 10 to 60 cm E39-RSB: 10 to 30 cm	---		
Min. sensing object		without slit: 2.0 mm 2-mm slit: 0.8 mm 1-mm slit: 0.4 mm 0.5-mm slit: 0.2 mm	E39-R1 Reflector: 10 mm E39-R3: 3 mm E39-R4: 1.0 mm	---		
Difference in direction between optical axis and mounting direction		±2° max. (checked along extended line in the mounting direction)		±2° max.		
Response time		0.5 ms max. for both operation and release				
Control output		30 VDC, 100 mA max. (residual voltage: 1 V max.) Open collector (residual voltage: 0.4 V max. at 16 mA)				
Self-diagnostic output		Only Sensors with self-diagnostic function: 50 mA max, 30 VDC (residual voltage: 1 V max.), open collector (residual voltage: 0.4 V max. 16 mA)				
External diagnostic input	Input Voltage	With emitter OFF: NPN: 0 V short-circuit or 1.5 V max. (push current: 1 mA max.) PNP: DC short-circuit or -1.5 V DC max. (pull current: 3 mA max.) With emitter ON: NPN/PNP Open (max. input voltage: 30 V max. with 0.1 mA current leakage)		---		
	Re-sponse time	0.5 ms max.				
Ambient illumination		Incandescent lamp: Sunlight:	Illumination on optical spot: 5,000 lx max. Illumination on optical spot: 10,000 lx max.			
Ambient temperature		Operating: -25°C to 55°C (with no icing) Storage: -40°C to 70°C (with no icing)				
Ambient humidity		Operating: 35% to 85% Storage: 35% to 95%				
Insulation resistance		20 MW min. (at 500 V DC)				
Dielectric strength		1,000 V AC, 50/60 Hz for 1 min				
Vibration resistance		Destruction: 10 to 55 Hz, 1.5-mm double amplitude (30G) 2 hrs each in three directions				
Shock resistance		Destruction: Approx. 50G 3 times each in three directions				
Enclosure ratings		IEC: IP67; NEMA: 4X				

Engineering Data

Parallel Operating Range (Typical)

E3S-AT□1

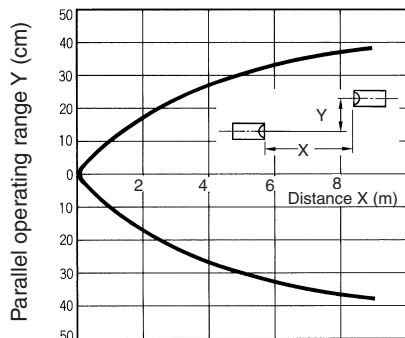

Operating Range (Typical)

E3S-AD□ (Left and Right)

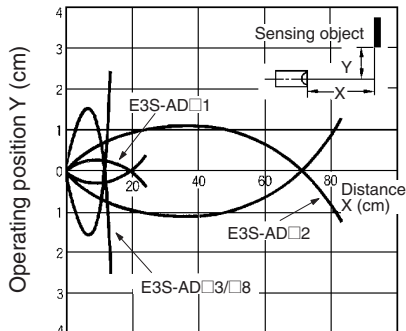

E3S-AD□ (Up and Down)

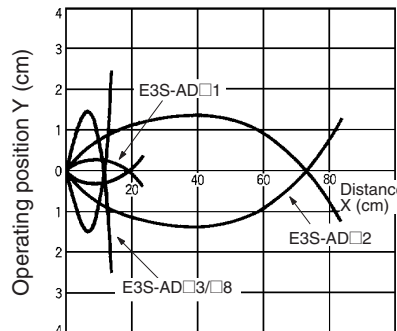

Sensing Distance vs. Object Size

E3S-AD□

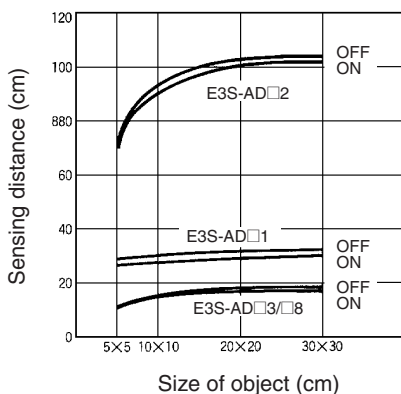

Excess Gain vs. Set Distance

E3S-AT□1 (Typical)

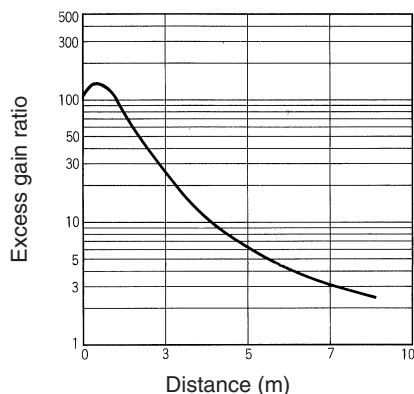

E3S-AD□1, -AD□2, -AD□3, -AD□8 (Detection of White Paper)

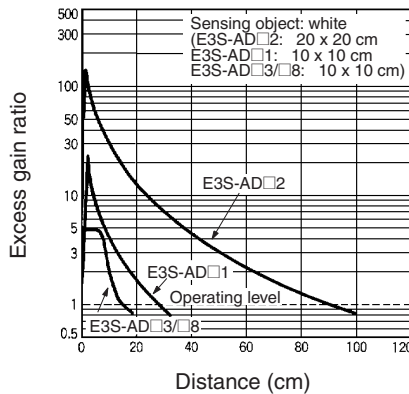

Reflector Parallel Movement

E3S-AR□1 (Typical)

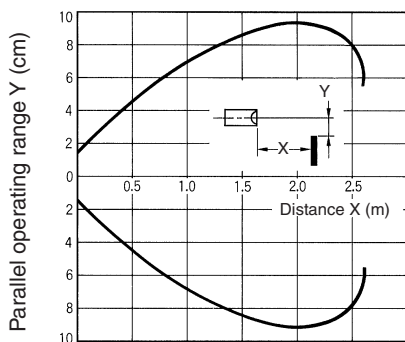

E3S-AR□1 (With Reflector E39-R1)

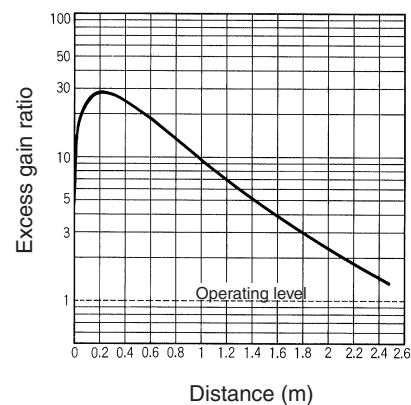

E3S-AD□1, -AD□2, -AD□3, -AD□8 (Detection of White Paper)

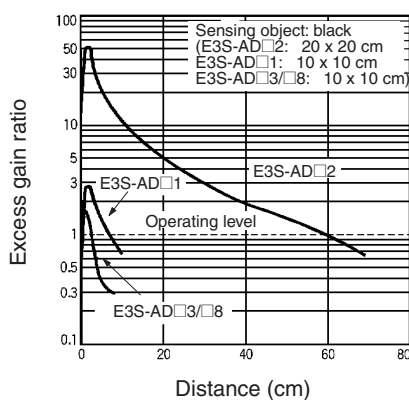

Operation

Output Circuits

Type	Model	Mode switch	Output transistor	Output circuit
NPN	E3S-AT11 E3S-AT16 E3S-AT61 E3S-AT66 E3S-AR11 E3S-AR16 E3S-AR61 E3S-AR66 E3S-AD13 E3S-AD63 E3S-AD18 E3S-AD68 E3S-AD11 E3S-AD16 E3S-AD61 E3S-AD66 E3S AD12 E3S-AD17 E3S-AD62 E3S AD67	Light ON	ON when light is received	<p>Emitter E3S-AT11/AT16/AT61/AT66</p>
		Dark ON	ON when light is not received	<p>Connector Type</p> <p>Emitter</p> <p>Reflective/Receiver</p> <p>Pin No. 2 is open.</p>
E3S-AT21 E3S-AT71 E3S-AD23 E3S-AD73 E3S-AD21 E3S-AD71 E3S-AD22 E3S-AD72		Light ON	ON when light is received	<p>Emitter E3S-AT21/AT71</p> <p>External diagnostic input ON OFF</p> <p>LED for emitter ON OFF</p> <p>Indicator (red) ON OFF</p>
		Dark ON	ON when light is not received	
E3S-AR21 E3S-AR71	Light ON	ON when light is received	ON when light is received	
	Dark ON	ON when light is not received		

E3S-A

Type	Model	Mode switch	Output transistor	Output circuit
PNP	E3S-AT31 E3S-AT36 E3S-AT81 E3S-AT86 E3S-AR31 E3S-AR36 E3S-AR81 E3S-AR86 E3S-AD33 E3S-AD83 E3S-AD38 E3S-AD88 E3S-AD31 E3S-AD36 E3S-AD81 E3S-AD86	Light ON	ON when light is received	<p>Emitter E3S-AT31/AT36/AT81/AT86</p>
			ON when light is not received	
	E3S-AD32 E3S-AD37 E3S-AD82 E3S-AD87	Dark ON	ON when light is not received	<p>Connector Type Emitter</p> <p>Reflective/Receiver</p> <p>Pin No. 2 is open.</p>
			ON when light is received	<p>Emitter E3S-AT41/AT91</p> <p>External diagnostic input: ON OFF (diagram)</p> <p>LED for emitter: ON OFF (diagram)</p> <p>Indicator (red): ON OFF (diagram)</p>
	E3S-AD41 E3S-AD91 E3S-AD42 E3S-AD92	Dark ON	ON when light is not received	
			ON when light is received	
	E3S-AR41 E3S-AR91	Light ON	ON when light is received	
		Dark ON	ON when light is not received	







Timing Charts

Type	Model	Mode switch	Output transistor	Timing chart
NPN	E3S-AT11 E3S-AT16 E3S-AT61 E3S-AT66 E3S-AR11 E3S-AR16 E3S-AR61 E3S-AR66 E3S-AD13 E3S-AD63	Light ON	ON when light is received.	
	E3S-AD18 E3S-AD68 E3S-AD11 E3S-AD16 E3S-AD61 E3S-AD66 E3S-AD12 E3S-AD17 E3S-AD62 E3S-AD67	Dark ON	ON when light is not received.	
	E3S-AT21 E3S-AT71 E3S-AD23 E3S-AD73 E3S-AD21 E3S-AD71 E3S-AD22 E3S-AD72 E3S-AR21 E3S-AR71	Light ON	ON when light is received.	
		Dark ON	ON when light is not received.	

Type	Model	Mode switch	Output transistor	Timing chart
PNP	E3S-AT31 E3S-AT36 E3S-AT81 E3S-AT86 E3S-AR31 E3S-AR36 E3S-AR81 E3S-AR86 E3S-AD33 E3S-AD83	Light ON	ON when light is received.	<p>Light received Light not received</p> <p>Light indicator (Red) ON OFF</p> <p>Output transistor ON OFF</p> <p>Load (relay) Operate Release</p> <p>(Between blue and black)</p>
	E3S-AD38 E3S-AD88 E3S-AD31 E3S-AD36 E3S-AD81 E3S-AD86 E3S-AD32 E3S-AD37 E3S-AD82 E3S-AD87	Dark ON	ON when light is not received.	<p>Light received Light not received</p> <p>Light indicator (Red) ON OFF</p> <p>Output transistor ON OFF</p> <p>Load (relay) Operate Release</p> <p>(Between blue and black)</p>
	E3S-AT41 E3S-AT91 E3S-AD43 E3S-AD93 E3S-AD41 E3S-AD91 E3S-AD42 E3S-AD92 E3S-AR41 E3S-AR91	Light ON	ON when light is received.	<p>Light received Light not received</p> <p>Light indicator (Red) ON OFF</p> <p>Output transistor ON OFF</p> <p>Load (relay) Operate Release</p> <p>T: Off-delay timer (0 to 100 ms)</p> <p>(Between blue and black)</p>
		Dark ON	ON when light is not received.	<p>Light received Light not received</p> <p>Light indicator (Red) ON OFF</p> <p>Output transistor ON OFF</p> <p>Load (relay) Operate Release</p> <p>T: Off-delay timer (0 to 100 ms)</p> <p>(Between blue and black)</p>

Self-diagnostic Function

With this function, the E3S-A checks changes in environmental conditions (especially a change in the ambient temperature) and self-diagnoses the resistance against the changes. The result is shown by the indicators or an output signal.

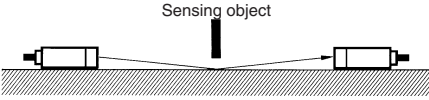
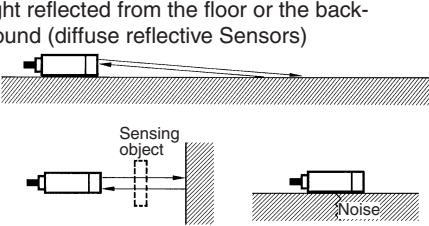
Amount of incident light	Green indicator	Indicator	Incident light indicator (red)	Self-diagnostic function	Self-diagnostic example
1.2 or more	Stable operating state with incident light: Stable operation is expected in the rated temperature range with the green indicator ON.	 Green Red	With light incident (red indicator: ON)	---	---
1.0 to 1.2	Conditional operating state with incident light: Stable operation is expected if the temperature fluctuation is within $\pm 10\%$ of the primary temperature.	 Green Red	Without light incident (red indicator: OFF)	The self-diagnostic alarm output alerts the user to this state if it continues for 0.3 s.	The optical axis misaligned by vibration. 
0.8 to 1.0	Stable operating state with no incident light: Stable operation is expected in the rated temperature range with the green indicator ON.	 Green Red			Light decreased by dust. 
0.8 or less	Stable operating state with no incident light: Stable operation is expected in the rated temperature range with the green indicator ON.	 Green Red			With light leakage (through-beam and retroreflective Sensors)  Light reflected from the floor or the background (diffuse reflective Sensors) 

External Diagnostic Input Function

To switch the emission off, short-circuit the pink and the blue cords of the emitter of the E3S-AT or the E3S-AR with the NPN output feature. For the E3S-AT or the E3S-AR with the PNP output feature, short-circuit the pink and the brown cords. With this function, the operating status can be checked before operation.

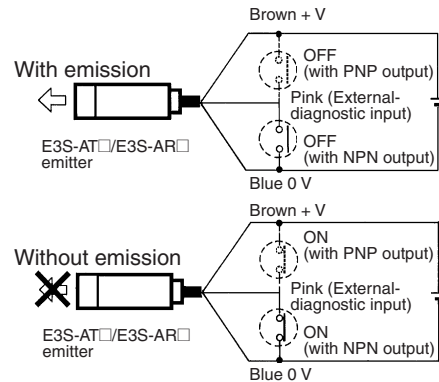

E3S-AT□/E3S-AR□ Emitter

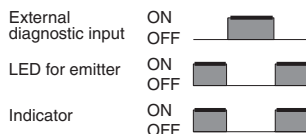
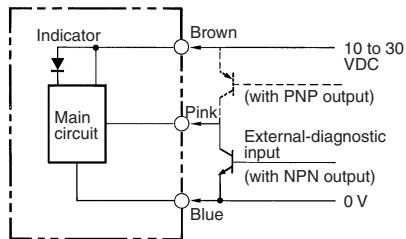

The sensor is normal if the control output varies when the self-diagnostic external input is ON and OFF. The sensor is abnormal if the control output does not vary when the self-diagnostic external input is turned ON or OFF.

Note: Before using the self-diagnostic external input function, the incident light beam to the sensor must not be blocked by an object.

Timer and Turbo Switch (Sensors with Self-diagnostic Output Function)

The E3S-A Sensor equipped with the self-diagnostic feature incorporates an OFF-delay timer that can be adjusted within a range of 0 to 100 ms.

The emitter of the through-beam sensor with the self-diagnostic feature incorporates a turbo switch. When this switch is on, the intensity of the red LED light source can be increased to

make a brighter spot. The OFF-delay time adjustor of the retroreflective and the 20-cm diffuse reflective sensor is used as a turbo switch. When the adjustor is pressed, it functions as a turbo switch to automatically increase the power of the light source to create a brighter light spot. Do not press the adjustor when turning it

Sensitivity Adjustment (Reflective Sensors)

Item	Position A	Position B	Setting
Sensing condition			---
Sensitivity adjustor			
Indicators	OFF (green) STABILITY (green) ON (red) LIGHT (red)	OFF (green) STABILITY (green) OFF (red) LIGHT (red)	OFF (green) STABILITY (green) ON (red) LIGHT (red)
Procedure	Locate a sensing object at the sensing distance, set the sensitivity adjustor to the minimum scale position, and gradually increase sensitivity by turning the sensitivity adjustor clockwise until the incident light indicator (red LED) is ON. Position A is where the indicator has turned ON. Regard the maximum scale position as Position A if the indicator does not turn ON at full sensitivity.	Remove the sensing object and gradually decrease sensitivity by turning the sensitivity adjustor counterclockwise from the maximum scale position until the incident light indicator (red LED) is OFF. Position B is where the indicator has turned off. Regard the minimum scale position as Position B if the indicator does not turn ON at minimum sensitivity.	Set the sensitivity indicator to the position between Positions A and B (in some cases, Positions A and B are opposite of the above example). The photoelectric sensor will then work normally if the stability indicator (green) is lit with and without the sensing object. If it is not lit, stable operation cannot be expected, in which case a different detection method must be applied.

Unlike conventional photoelectric sensors, the variation in the sensitivity of E3S photoelectric sensors is minimal. This means the sensitivity can be adjusted on only a single photoelectric sensor, and then the adjustors on the other photoelectric sensors can be set to the same scale position. There is no need to adjust the sensitivity of each photoelectric sensor individually.

Turbo Function (Turbo Switch)

With the turbo function switched ON, the light spot is visible even at a distance of 20 cm, making it easy to check the sensing position and the angle of the optical axis.

1. After using the turbo function, readjust the OFF-delay time that had been set, since the OFF-delay time could have been changed when the turbo switch (which is on the OFF-delay time adjustor) was pressed.
2. Press the OFF-delay time adjustor to switch ON the turbo function with a maximum force of 1 kg and within a maximum period of 3 mins. (The photoelectric sensor, however, will not malfunction even if the turbo function is switched on for more than 3 mins.)

With Turbo Switch ON

The turbo function is effective with the turbo switch pressed, and the function is reset automatically when released.

Normal Operating Condition

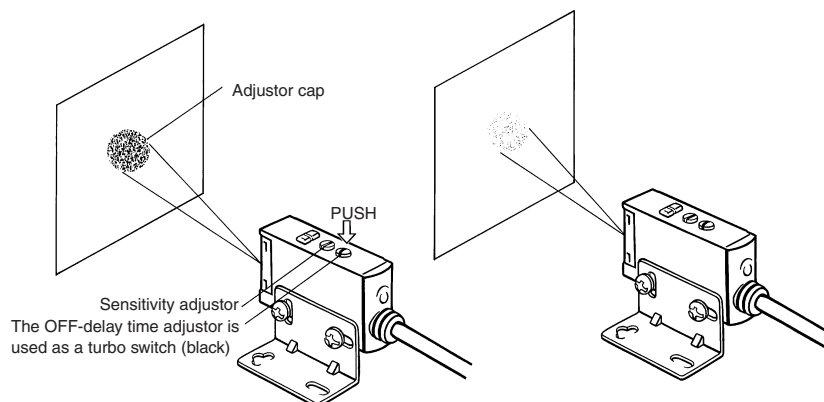

Operating Mode Selection

As shown in the following illustration, the E3S-A has an operating mode selector on the panel where the Receiver connector is located. With this operating mode selector, the E3S-A is in either dark-ON or light-ON mode.

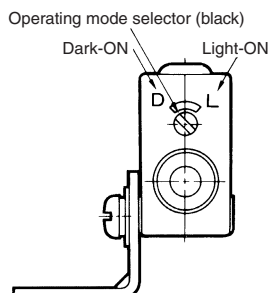

Dimensions

Sensors

Prewired Type

**E3S-AT11, E3S-AT31
(Receiver)**

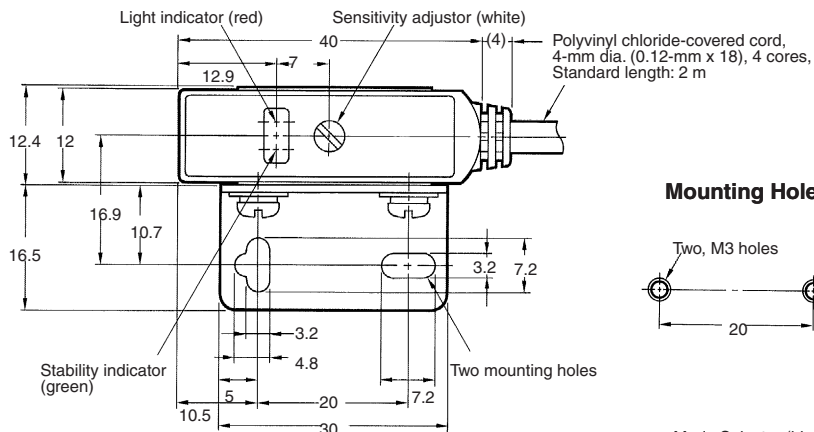
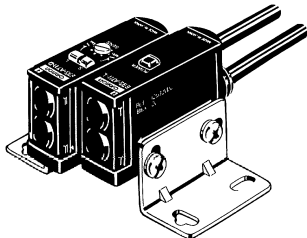

Mounting Holes

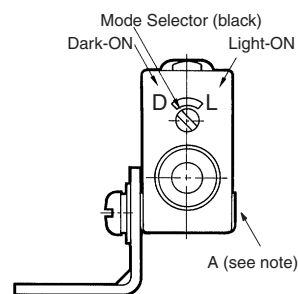
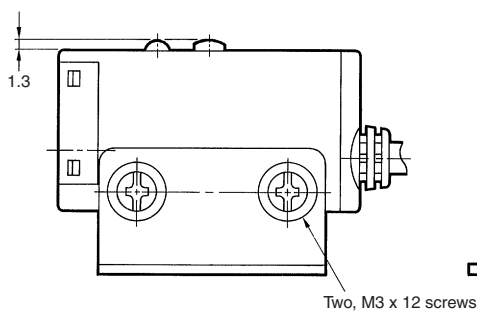
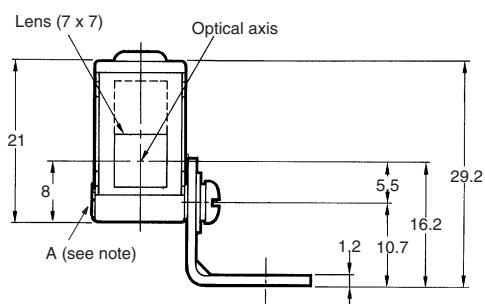
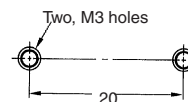

Note: The mounting bracket can be attached to side A.

**E3S-AT11, E3S-AT31
(Emitter)**

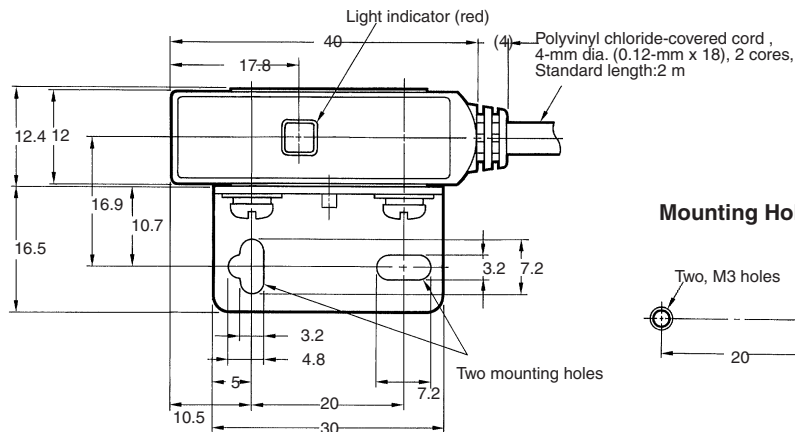

Mounting Holes

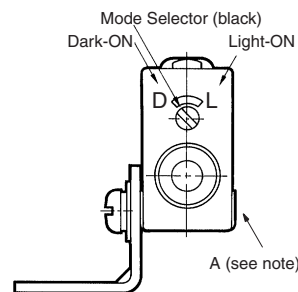
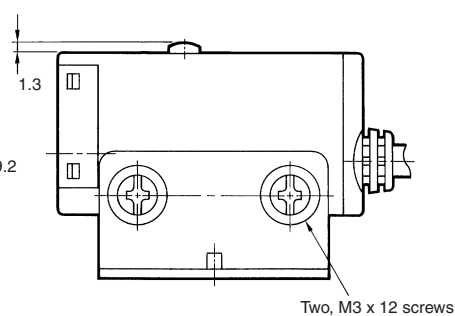
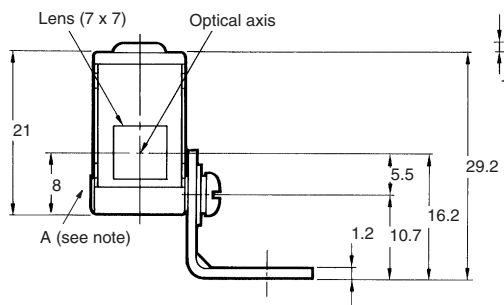
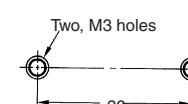

Note: The mounting bracket can be attached to side A.

**E3S-AT21, E3S-AT41
(Receiver)**

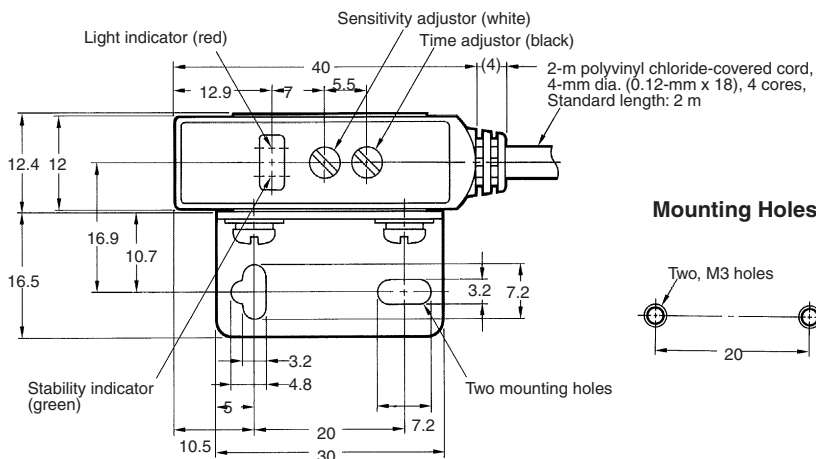
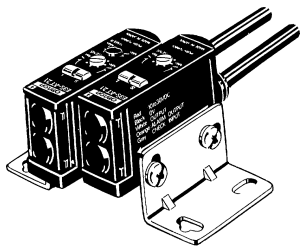

Mounting Holes

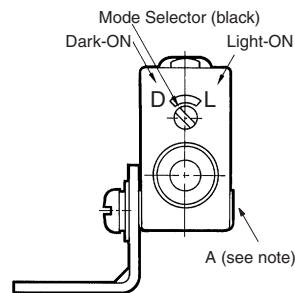
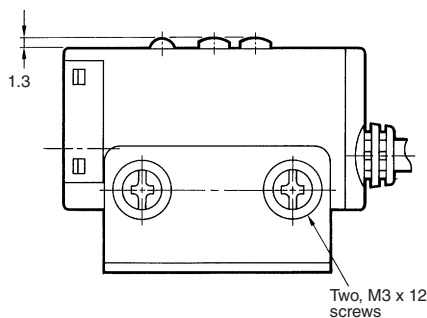
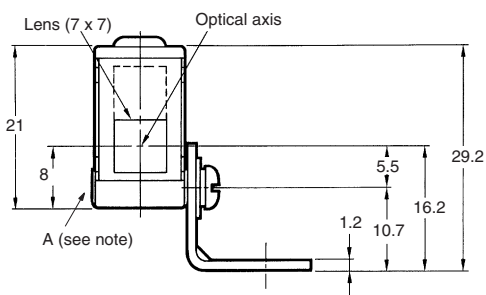
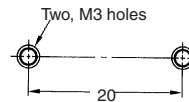

Note: The mounting bracket can be attached to side A.

**E3S-AT21, E3S-AT41
(Emitter)**

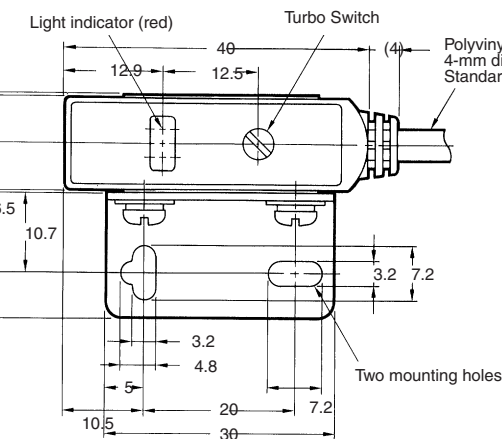
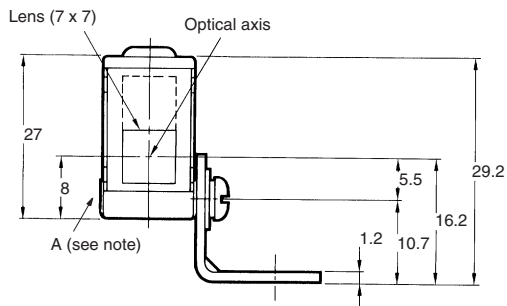

Mounting Holes

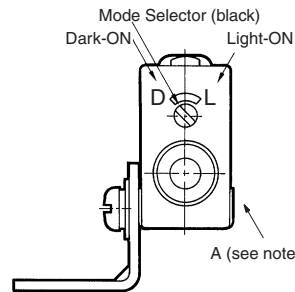
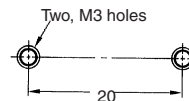

Two, M3 x 12 screws

Note: The mounting bracket can be attached to side A.

**E3S-AR11, E3S-AR31
E3S-AR21, E3S-AR41**

OFF-delay time adjustor/turbo switch (black) (see Note 1)
Turn to adjust the OFF-delay time: push to switch turbo function ON

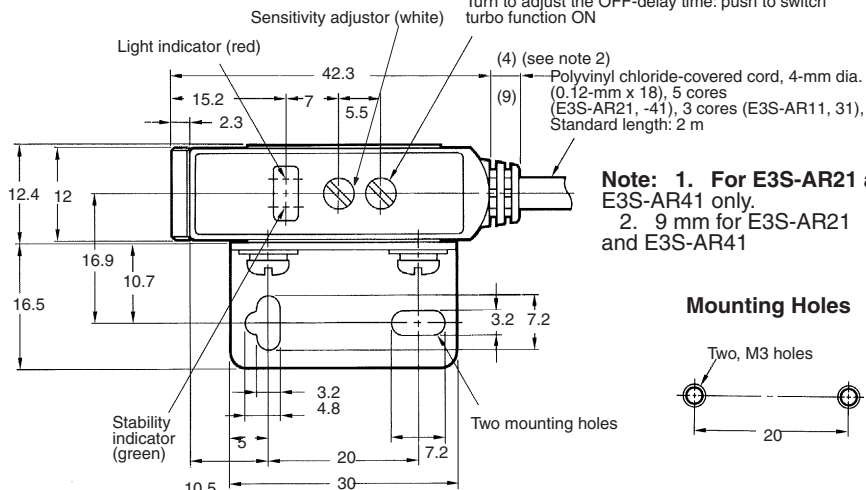

Mounting Holes

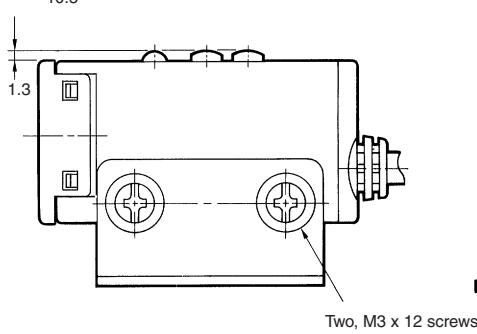
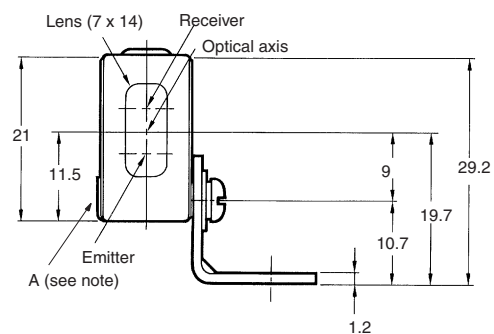
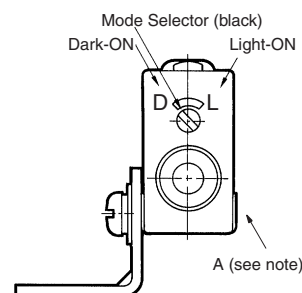
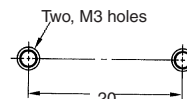

Note: The mounting bracket can be attached to side A.

**E3S-AD11, E3S-AD31
E3S-AD13, E3S-AD31
E3S-AD12, E3S-AD32**

Polyvinyl chloride-covered cord, 4-mm dia. (0.12-mm x 18), 3 cores, Standard length: 2 m

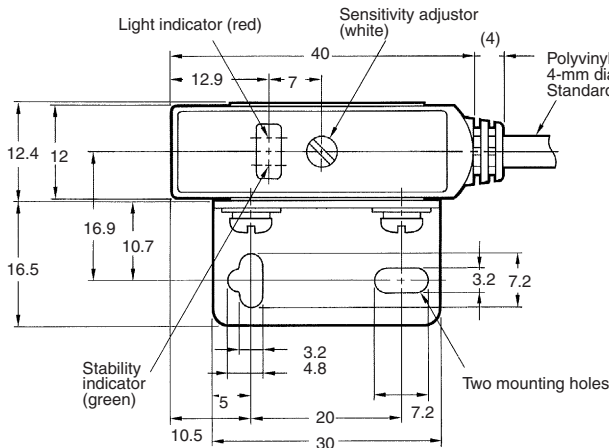

Mounting Holes

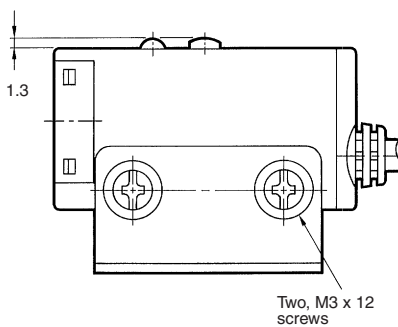
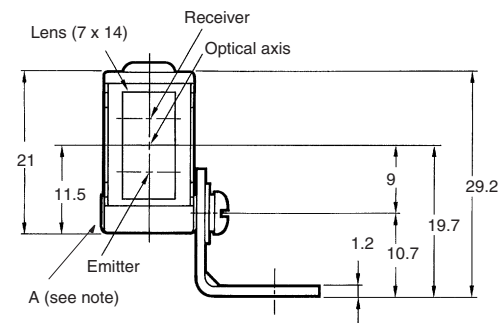
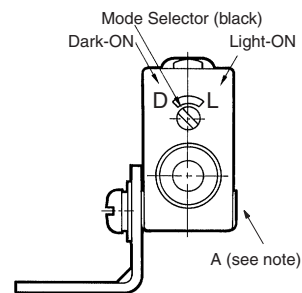
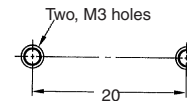

Note: The mounting bracket can be attached to side A.

**E3S-AT61, E3S-AT81
(Emitter)**

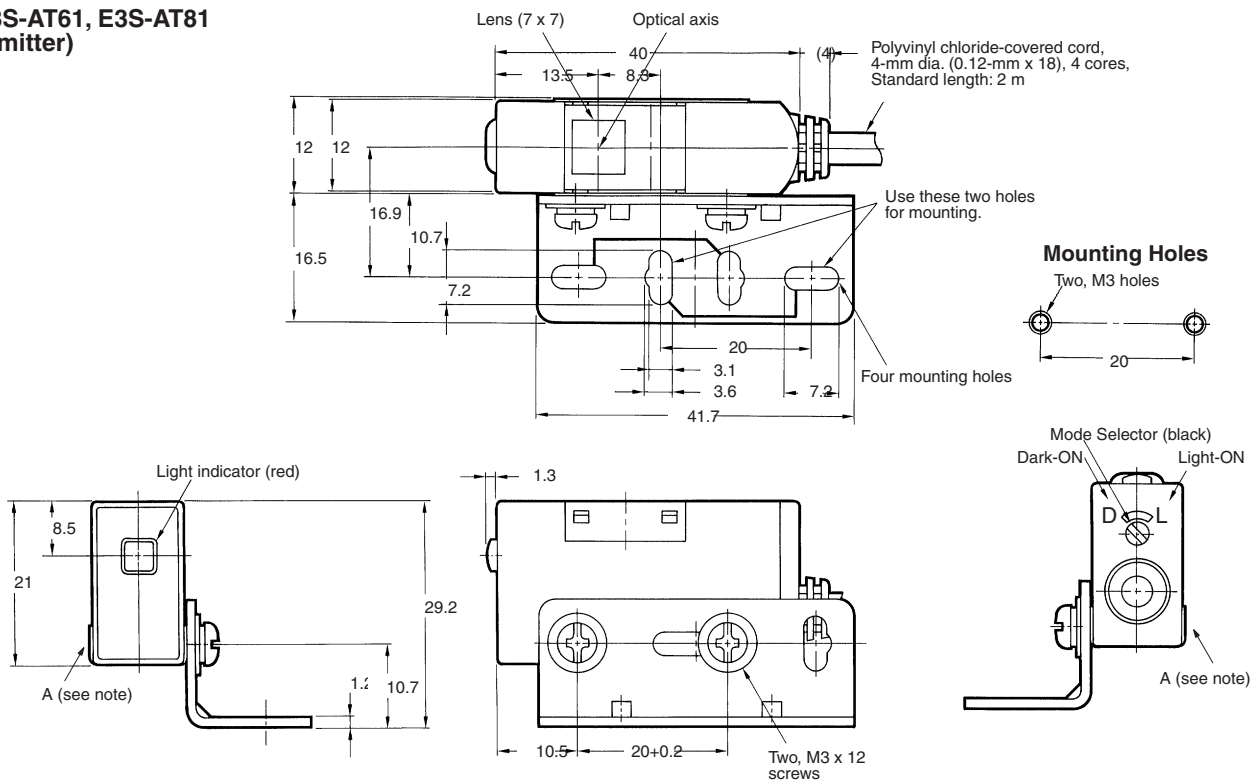

Note: The mounting bracket can be attached to side A.

**E3S-AT71, E3S-AT91
(Receiver)**

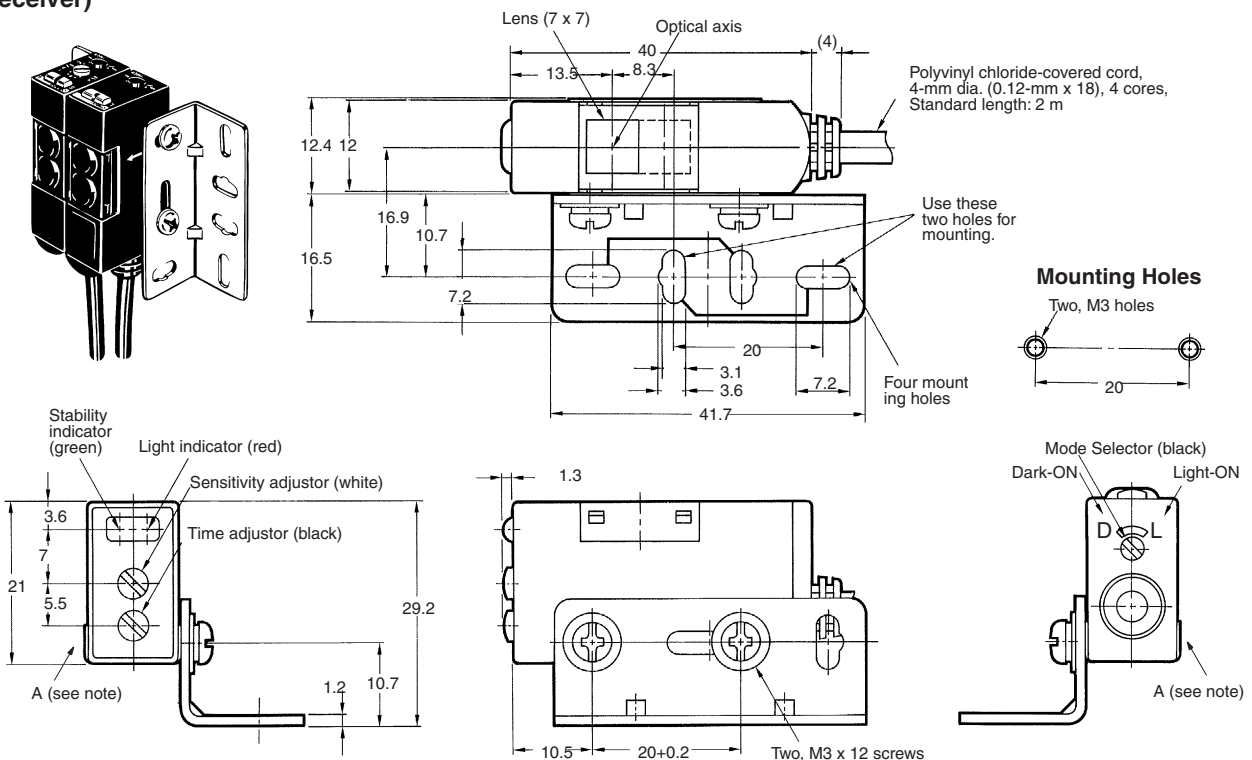

Note: The mounting bracket can be attached to side A.

**E3S-AT71, E3S-AT91
(Emitter)**

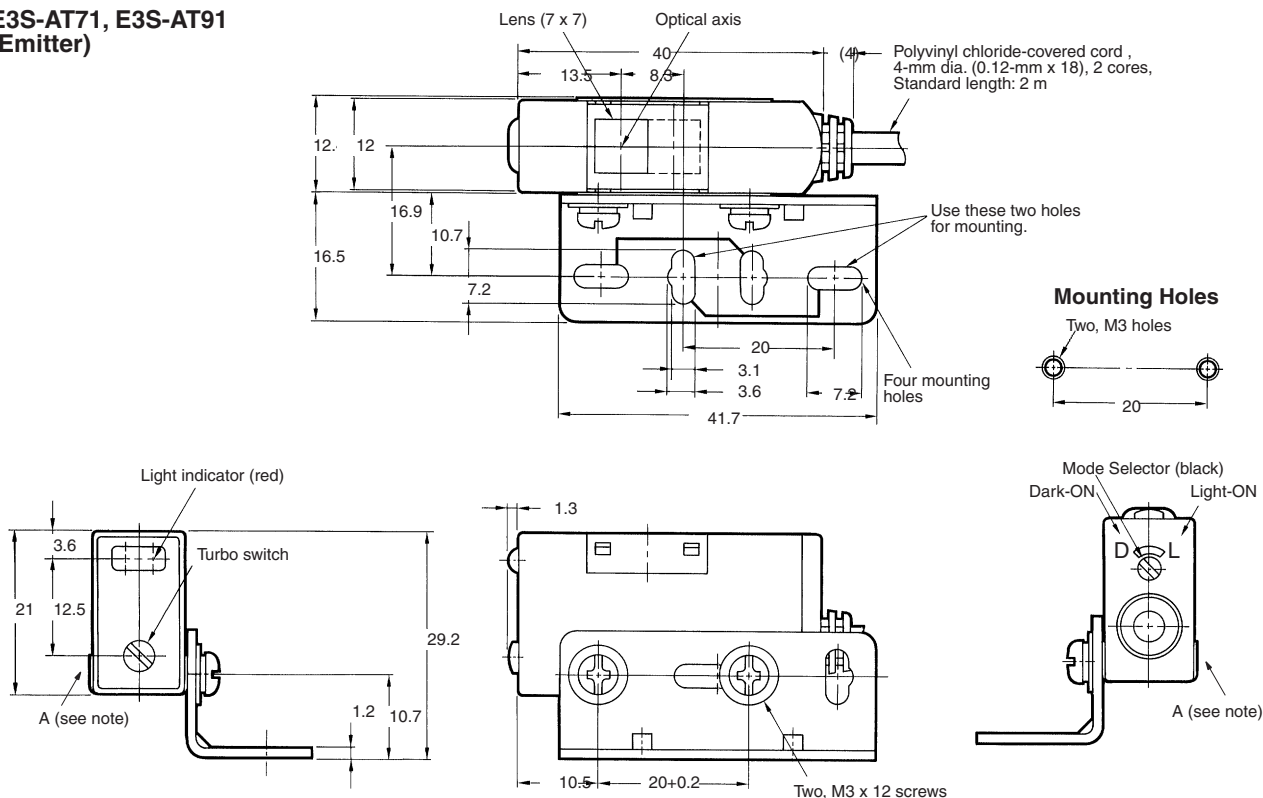

Note: The mounting bracket can be attached to side A.

**E3S-AR61, E3S-AR81
E3S-AR71, E3S-AR91**

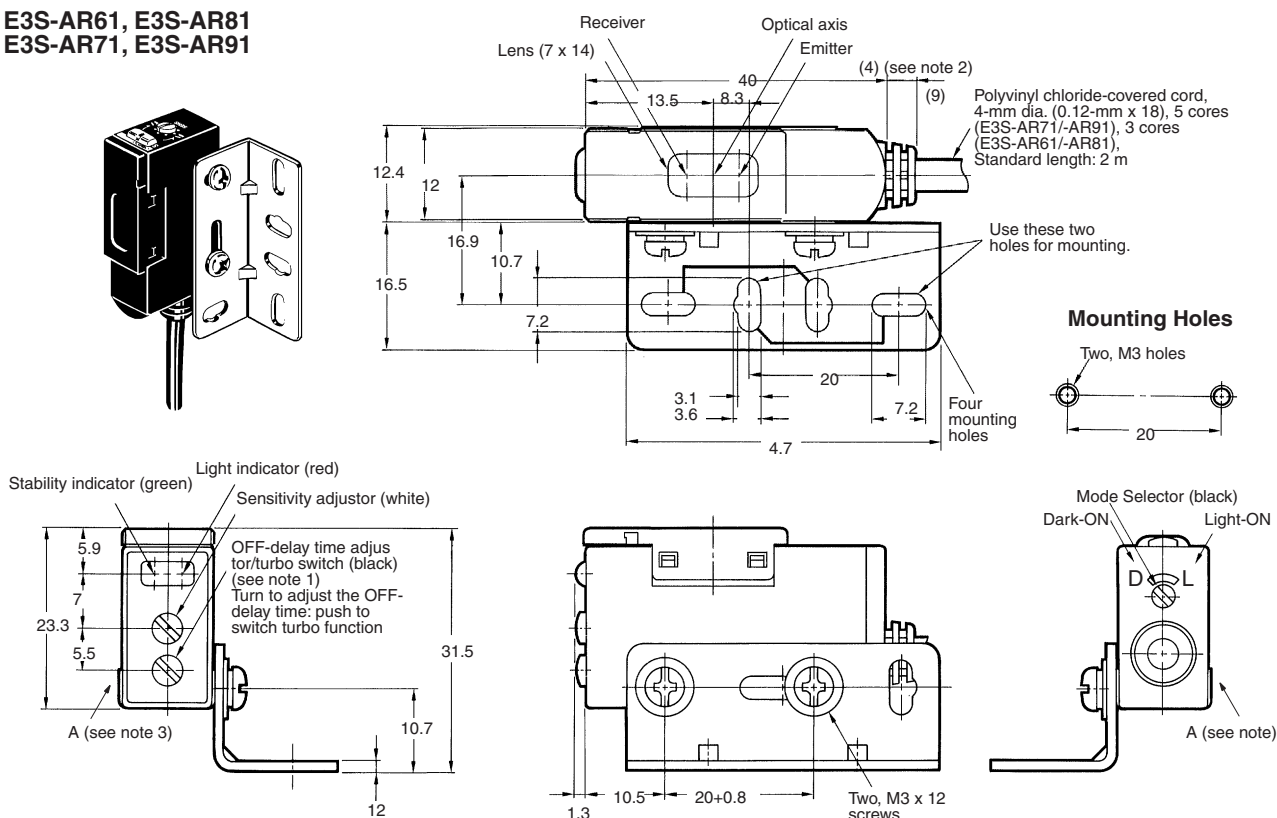

Note: 1. Turbo switch is only for E3S-AR71 and E3S-AR91.
2. 9.7 mm for E3S-AR71/-AR91.
3. The mounting bracket can be attached to side A.

**E3S-AD61, E3S-AD81
E3S-AD63, E3S-AD83
E3S-AD62, E3S-AD82**

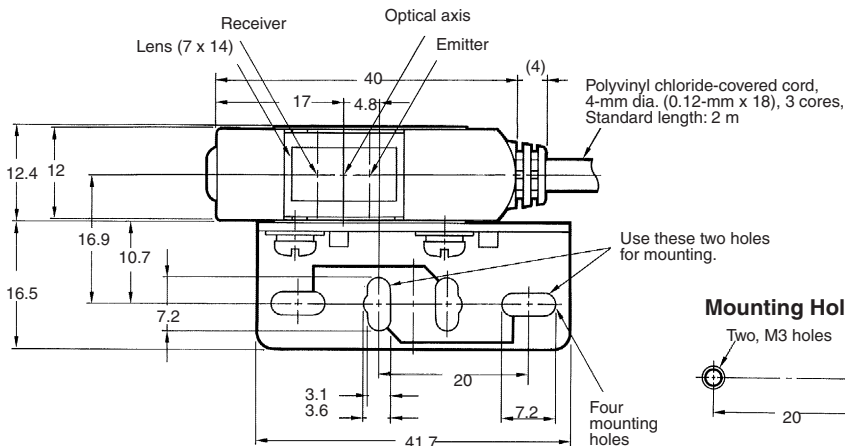
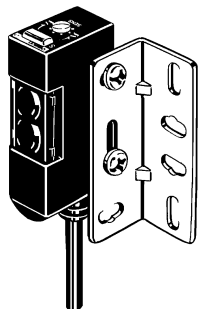

Mounting Holes

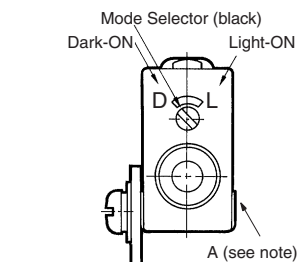
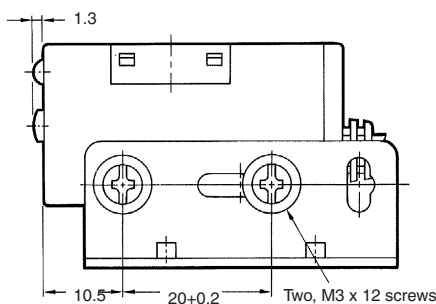
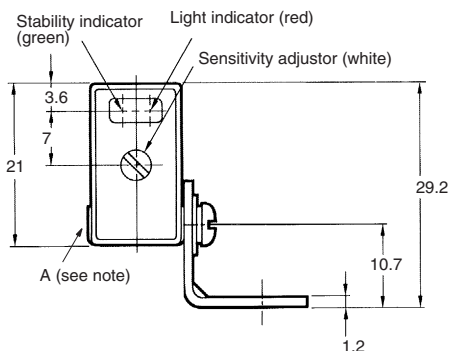
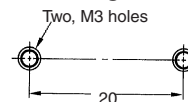

Note: The mounting bracket can be attached to side A.

**E3S-AD71, E3S-AD91
E3S-AD73, E3S-AD93
E3S-AD72, E3S-AD92**

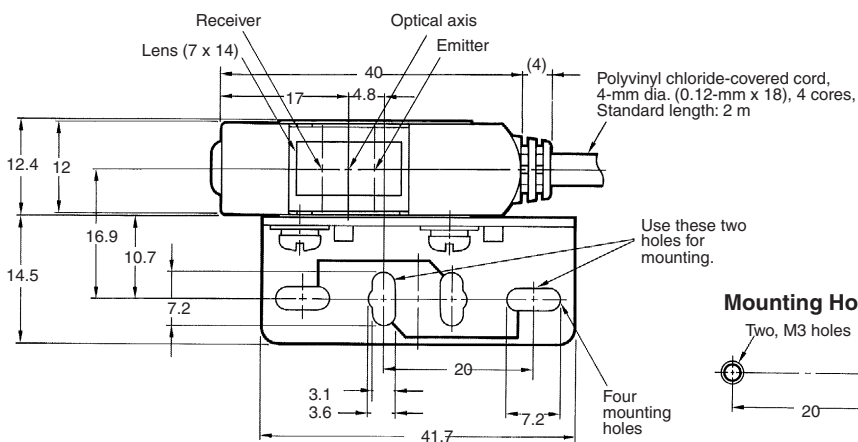
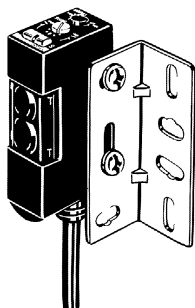

Mounting Holes

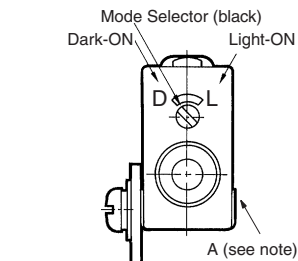
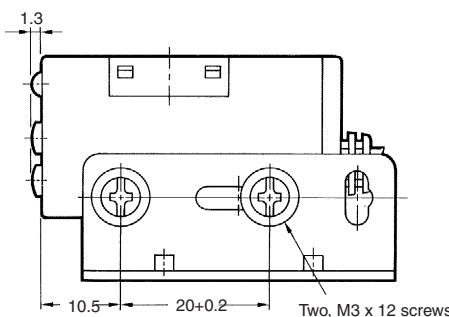
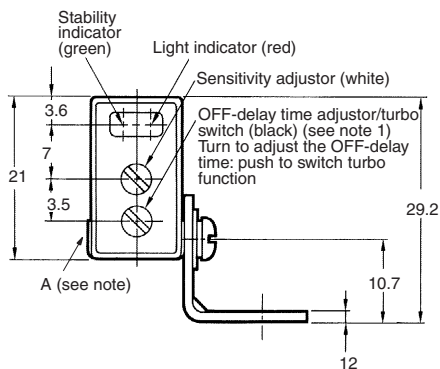
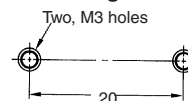

**Note: 1. Turbo switch is only for E3S-AD71 and E3S-AD91.
2. The mounting bracket can be attached to side A.**

Connector Type

E3S-AT16, E3S-AT36
(Receiver)

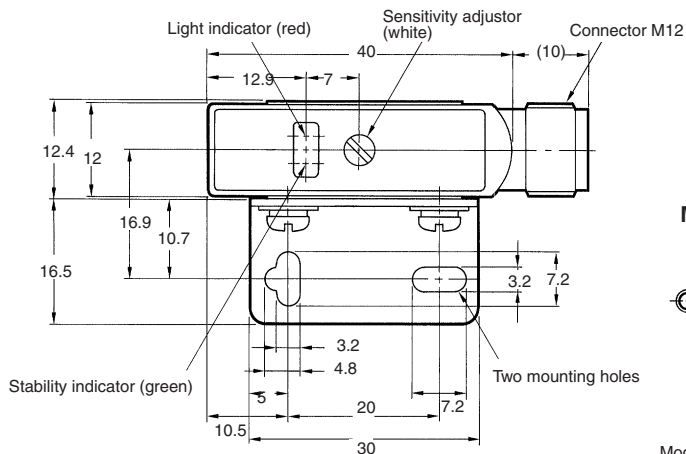
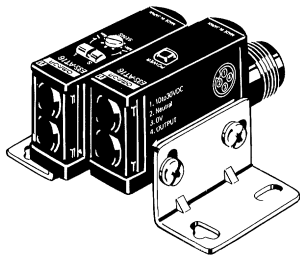

Mounting Holes

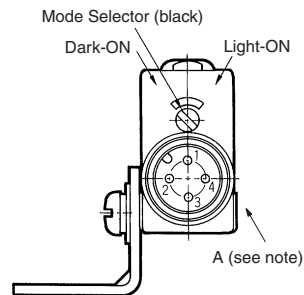
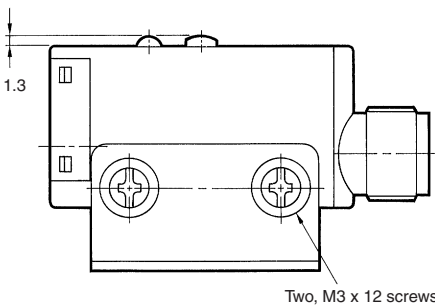
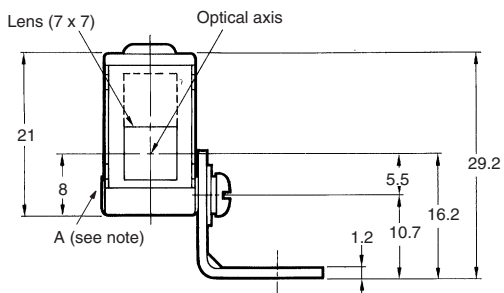
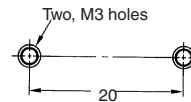

Note: The mounting bracket can be attached to side A.

E3S-AT16, E3S-AT36
(Emitter)

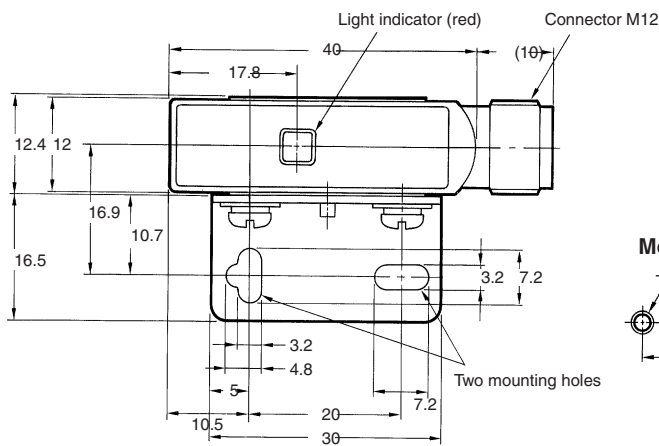

Mounting Holes

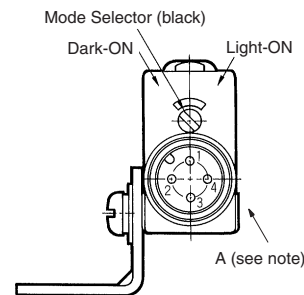
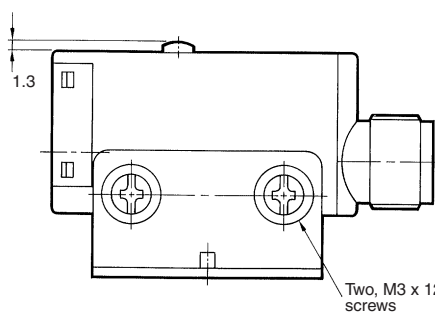
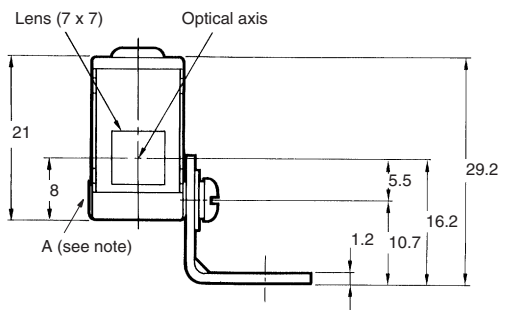
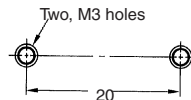

Note: The mounting bracket can be attached to side A.

E3S-AR16, E3S-AR36

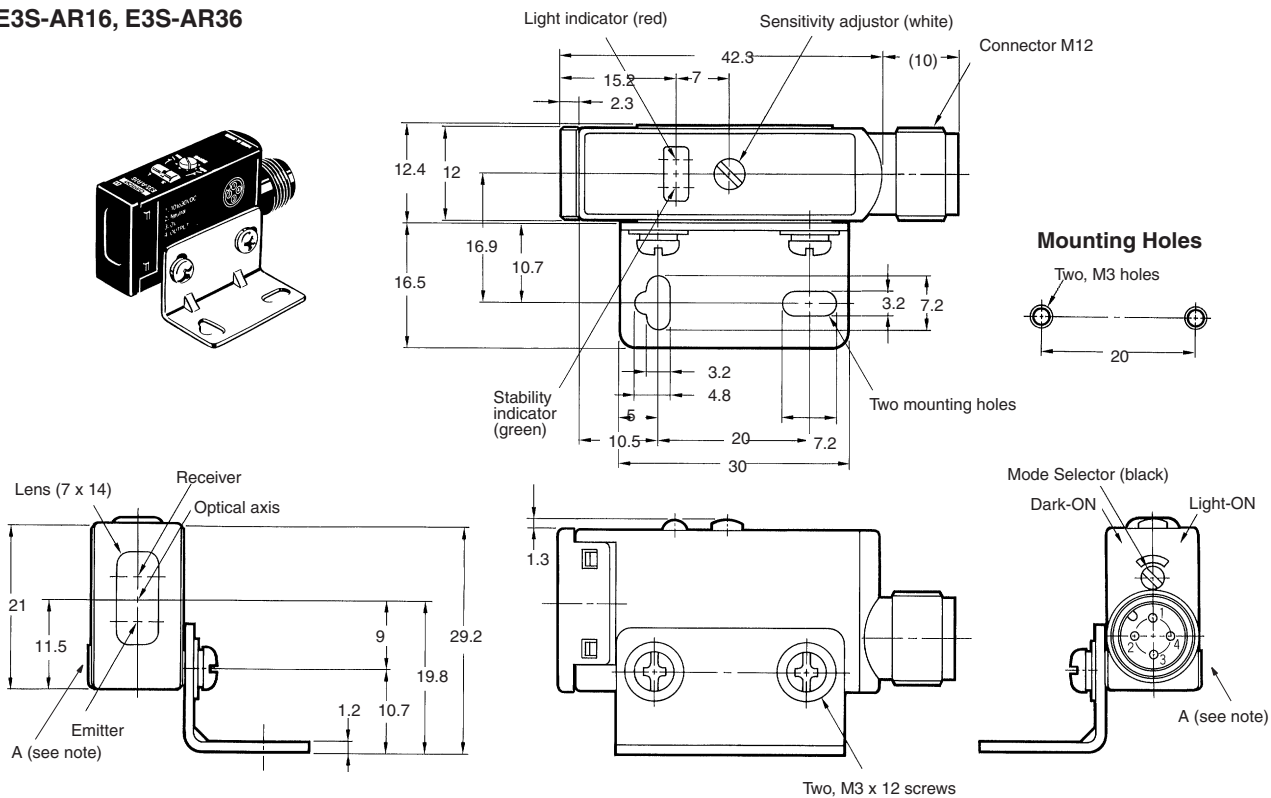

Note: The mounting bracket can be attached to side A.

**E3S-AD16, E3S-AD36
E3S-AD18, E3S-AD38
E3S-AD17, E3S-AD37**

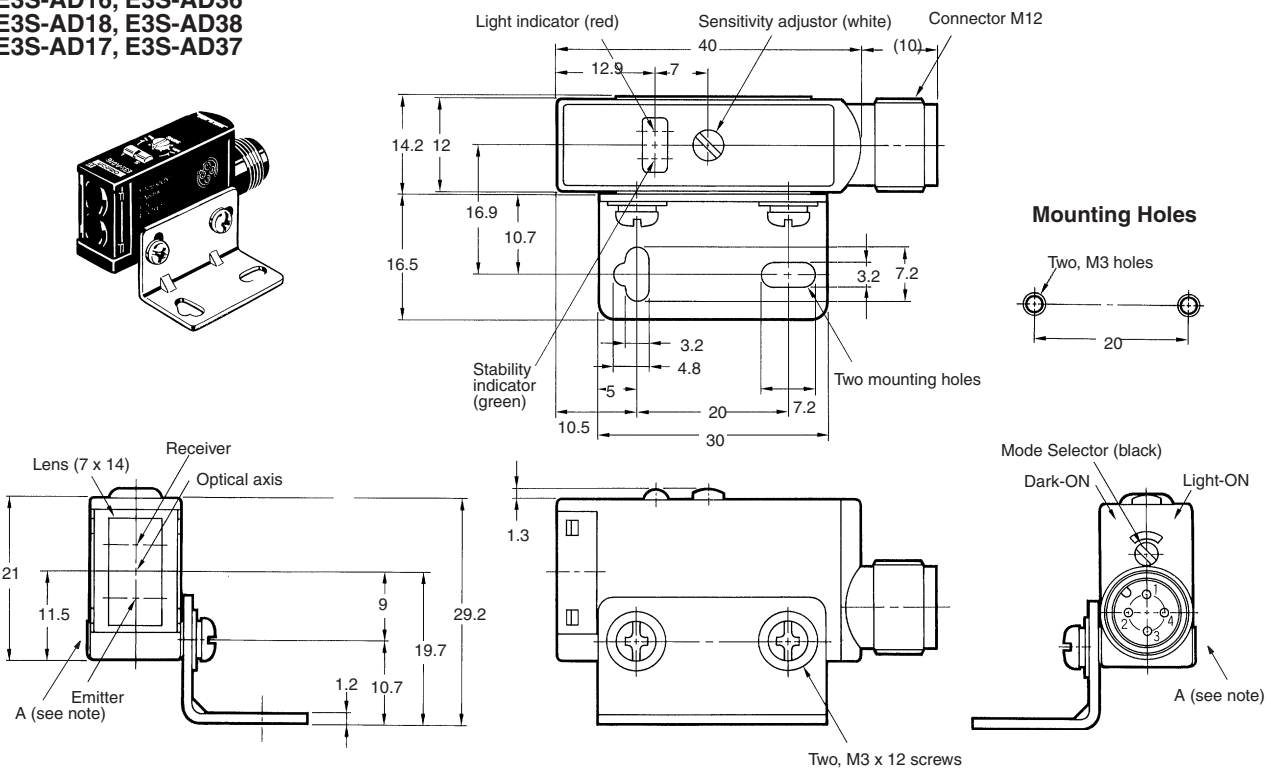

Note: The mounting bracket can be attached to side A.

**E3S-AT66, E3S-AT86
(Receiver)**

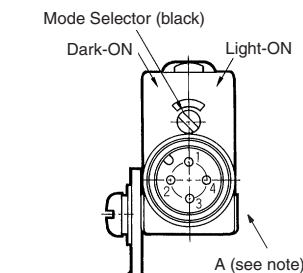
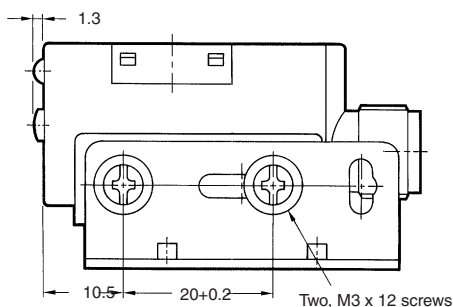
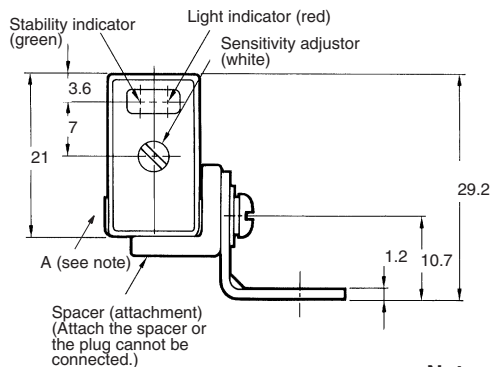
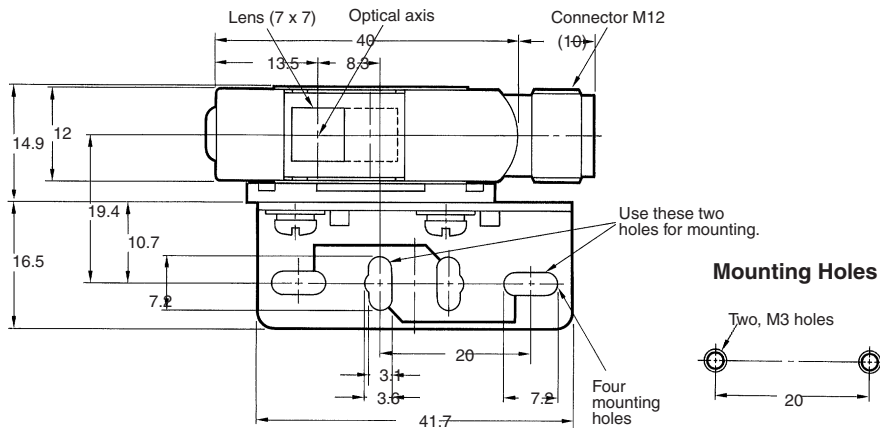
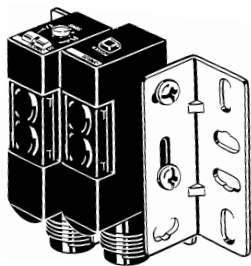

Note: The mounting bracket can be attached to side A.

**E3S-AT66, E3S-AT86
(Emitter)**

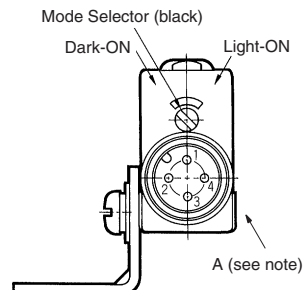
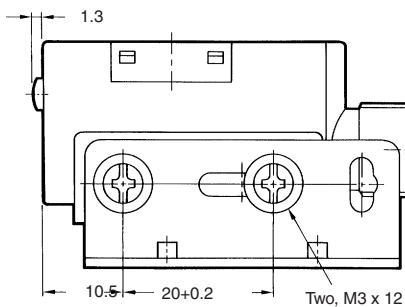
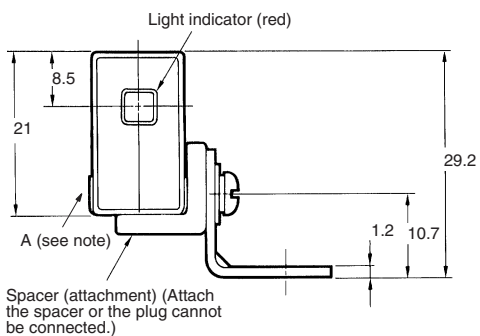
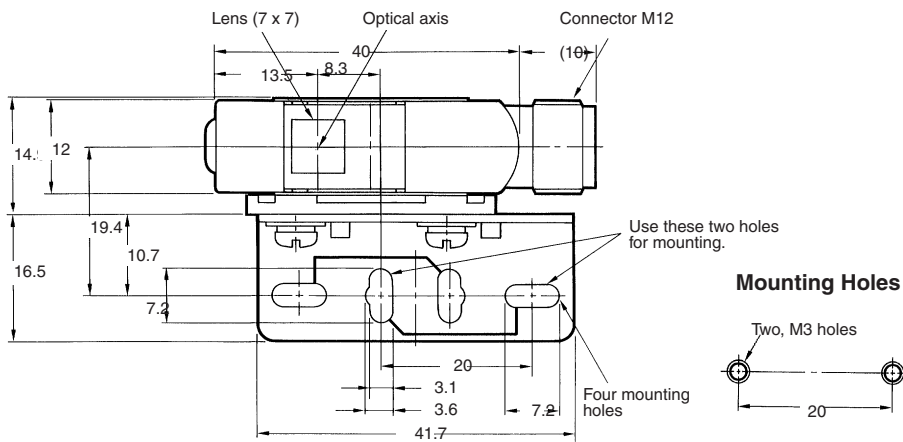

Note: The mounting bracket can be attached to side A.

E3S-AR66, E3S-AR86

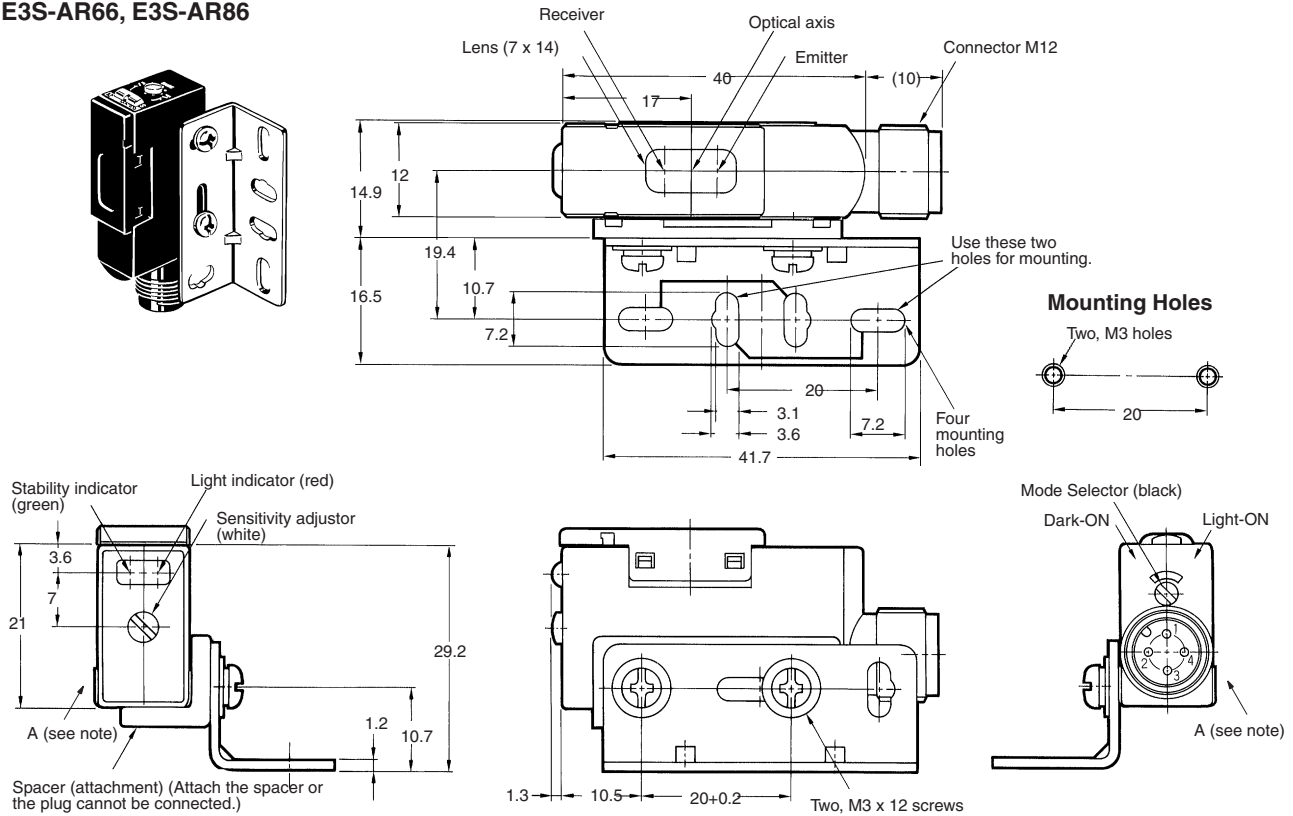

Note: The mounting bracket can be attached to side A.

**E3S-AD66, E3S-AD86
E3S-AD68, E3S-AD88
E3S-AD67, E3S-AD87**

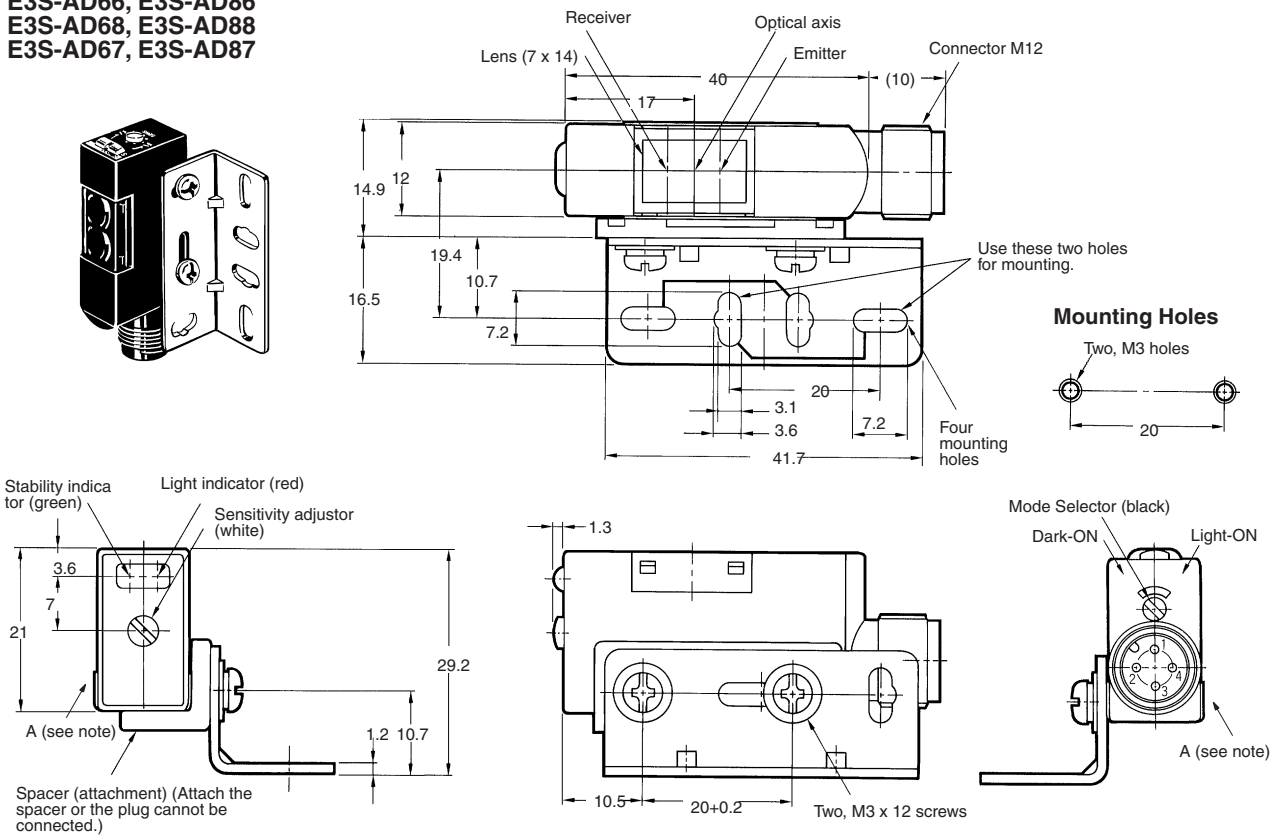

Note: The mounting bracket can be attached to side A.

Accessories

Plug (for E3S-A Connector type)

Straight Type
XS2F-D421-DC0-A

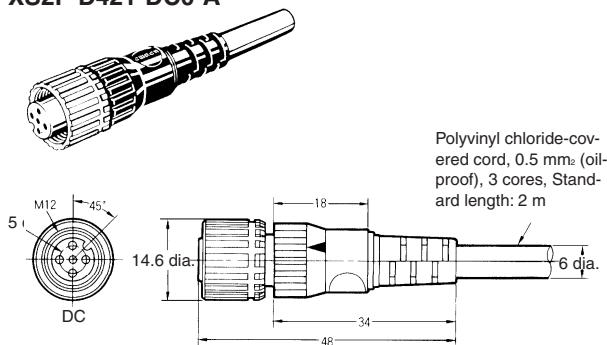

The XS2F-D421 Straight Cable Connector is also available. Refer to the output circuit diagram on page A-237.

Cable drawing direction	No. of conductors	Cord length	Model
Straight	3	2 m	XS2F-D421-DC0-A
	4		XS2F-D421-D80-A
	3	5 m	XS2F-D421-GC0-A
	4		XS2F-D421-G80-A

Attachments

Standard Mounting Bracket
(for E3S-A Horizontal Sensor)
E39-L69

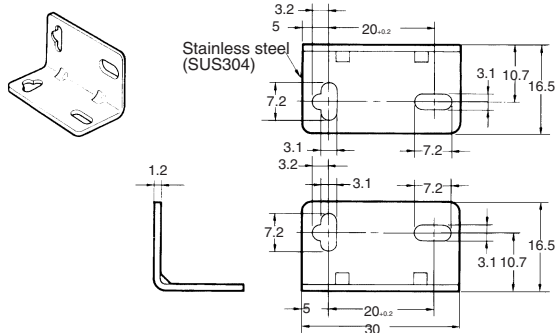

Standard Mounting Bracket
(for E3S-A Vertical Sensor)
E39-L70

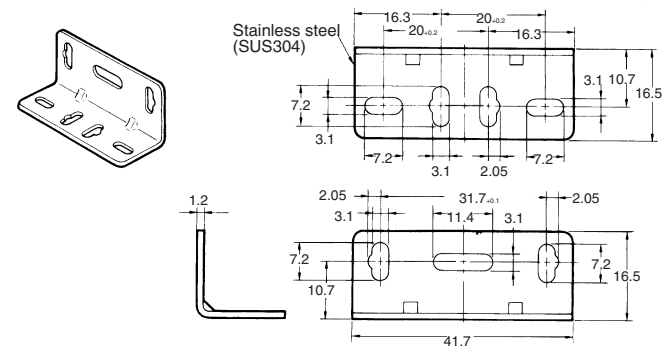

Close Mounting Plate (for E3S-A Connector Type)
E39-L60

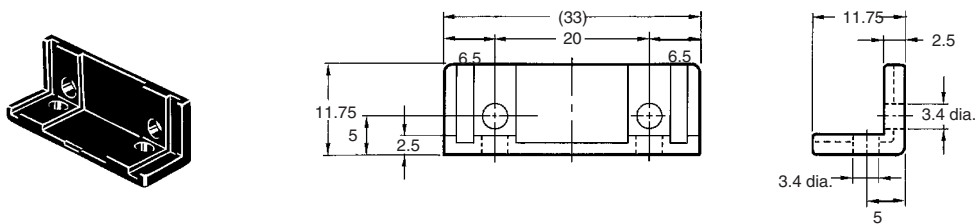

Sensitivity Adjustor Knob (for E3S-A)
E39-G2

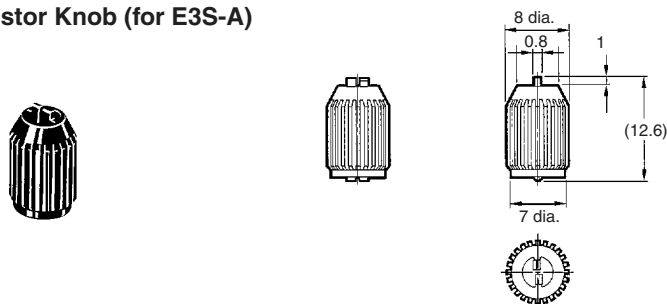

Retroreflector (Included with E3S-□R□□)
E39-R1

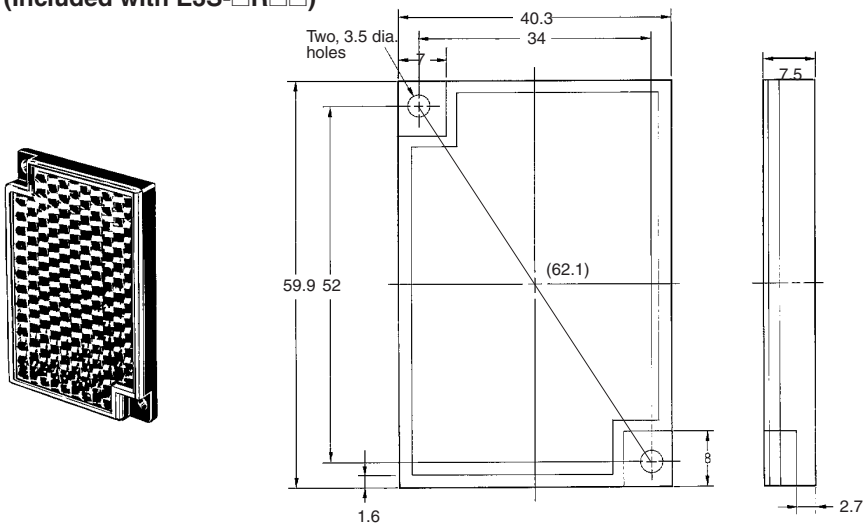

Accessories (Order Separately)

Vertical Mounting Bracket (for E3S-A)
E39-L59

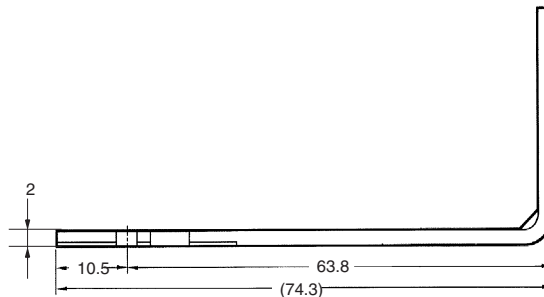
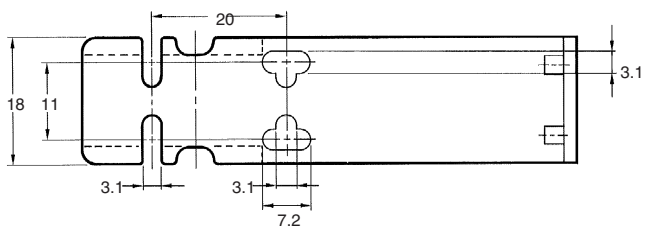
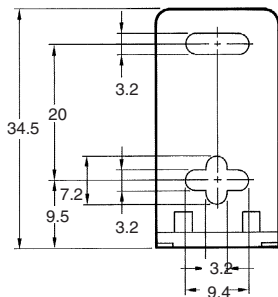
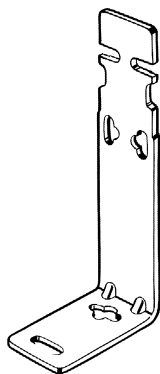

Mounting Example of E3S-A on E39-L59

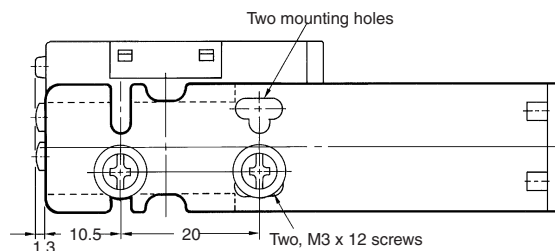
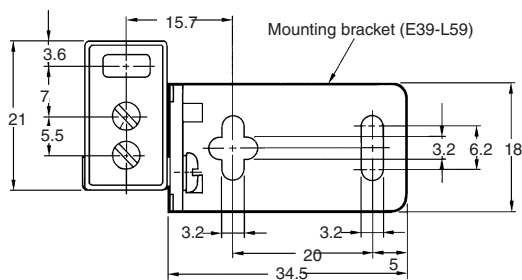
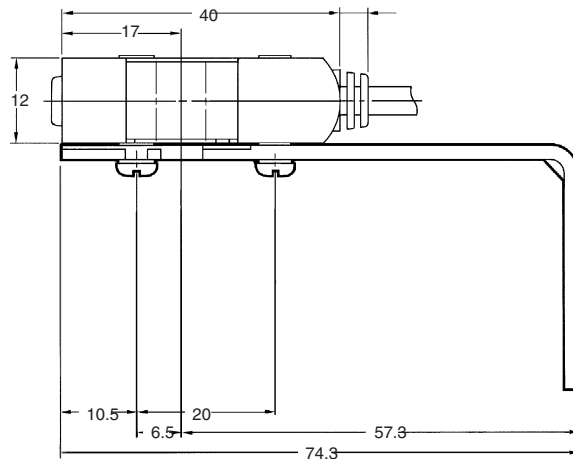

Mounting Example of E3S-A on E39-L81

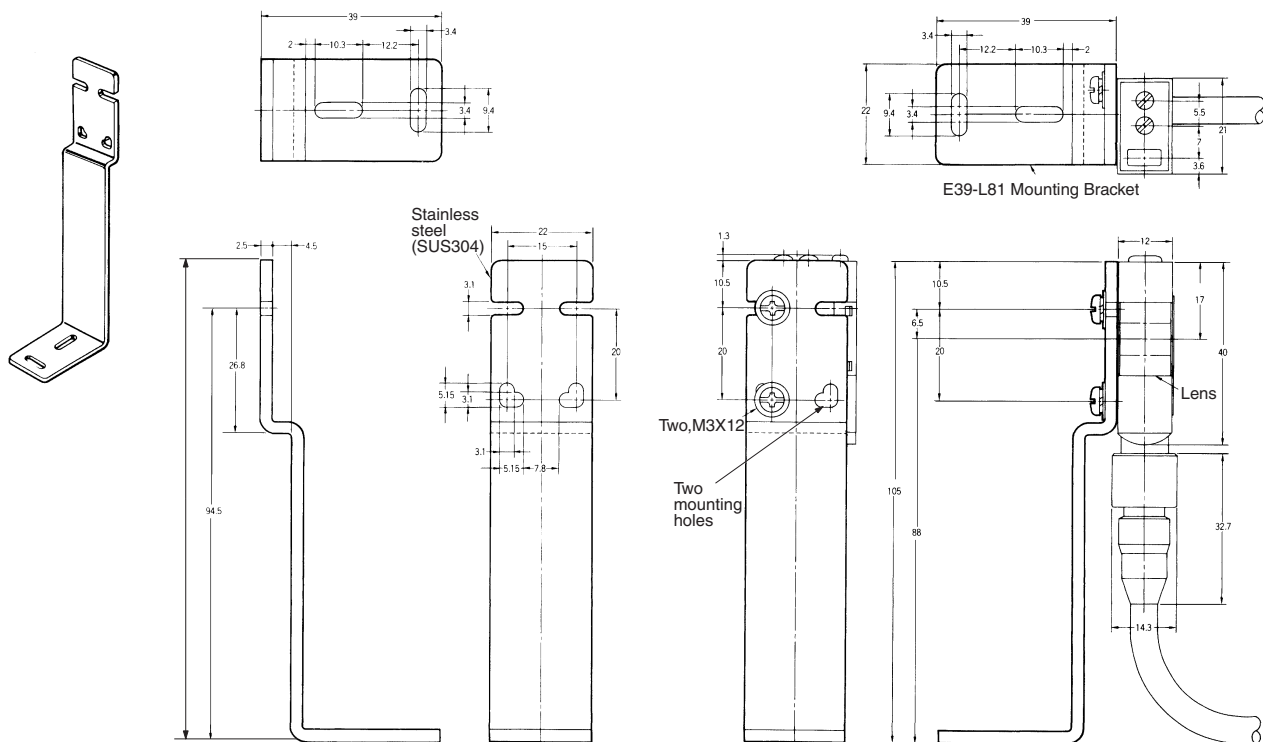

Slit (for E3S-A) E39-S46

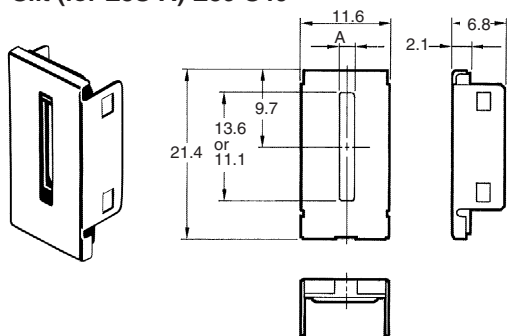

Note: The width of A is 0.5 mm, 1 mm, or 2 mm depending on the model.

Filters for Mutual Interference Prevention (for E3S-A) E39-E6

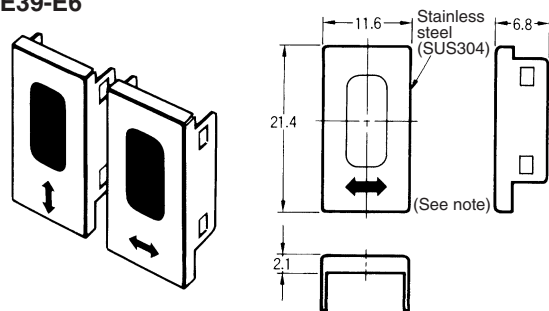

Note: Two vertical filters and two horizontal filters are sold together.

Mini-reflector E39-R4

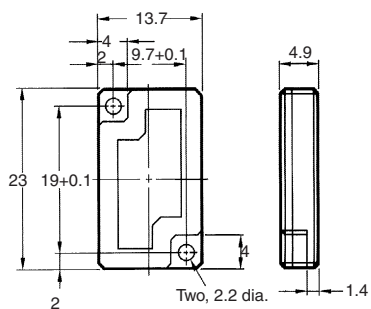

Optical Axis Confirmation Reflector (for E3S-A) E39-R5

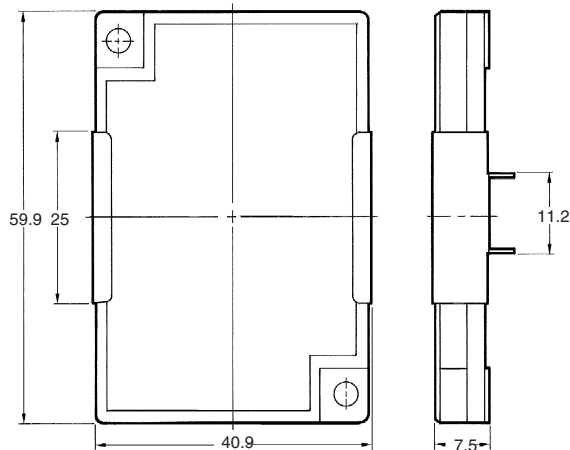
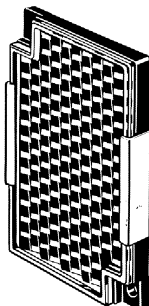
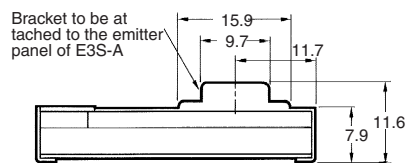

Small Reflector E39-R3

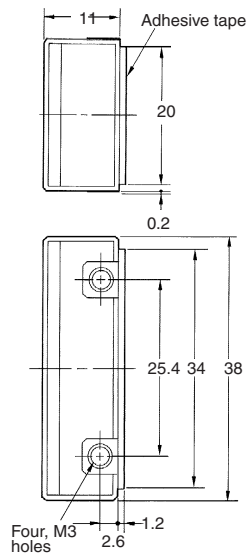
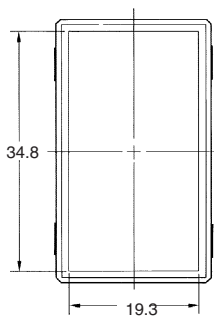
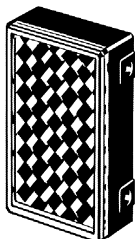

Reflecting Tape E39-RS3

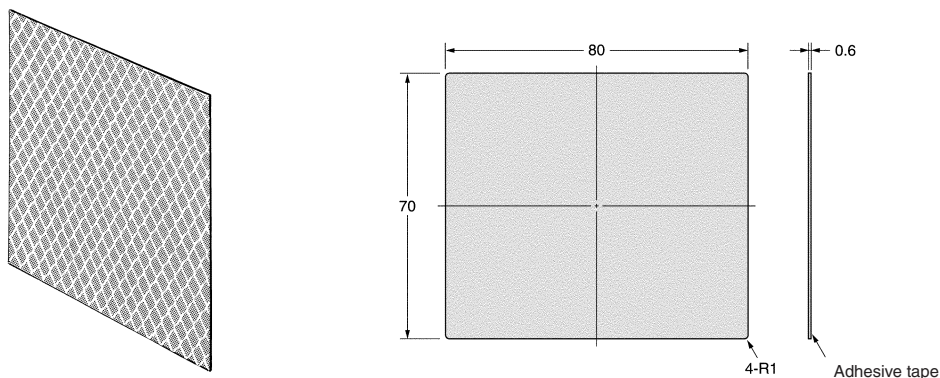

Item	E39-R3	E39-RS1	E39-RS2	E39-RS3	E39-R4
Directional angle	30° min.			2 to 20°	
Ambient temperature	Operating: -25°C to 55°C Storage: -40°C to 70°C	Operating: -25°C to 55°C Storage: 0°C to 40°C		Operating: -25°C to 55°C Storage: -40°C to 70°C	
Ambient humidity	Operating: 35% to 85% Storage: 35% to 95%	Operating: 35% to 85% Storage: 35% to 85%		Operating: 35% to 85% Storage: 35% to 95%	
Enclosure rating	IP67				

Note: The above reflector tapes are polarizing.

Installation

Connections (Without Self-diagnostic Function)

Load (Relay)

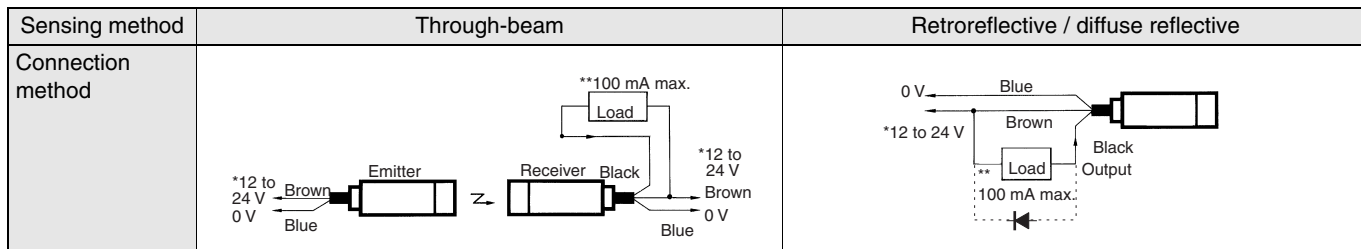

* 10 to 30 V for the E3S-A
 ** If the load is a relay, insert a surge absorbing diode between the coils of the relay.
 *** The connection examples are for sensors with the NPN output.

With Sensor Controller S3D2

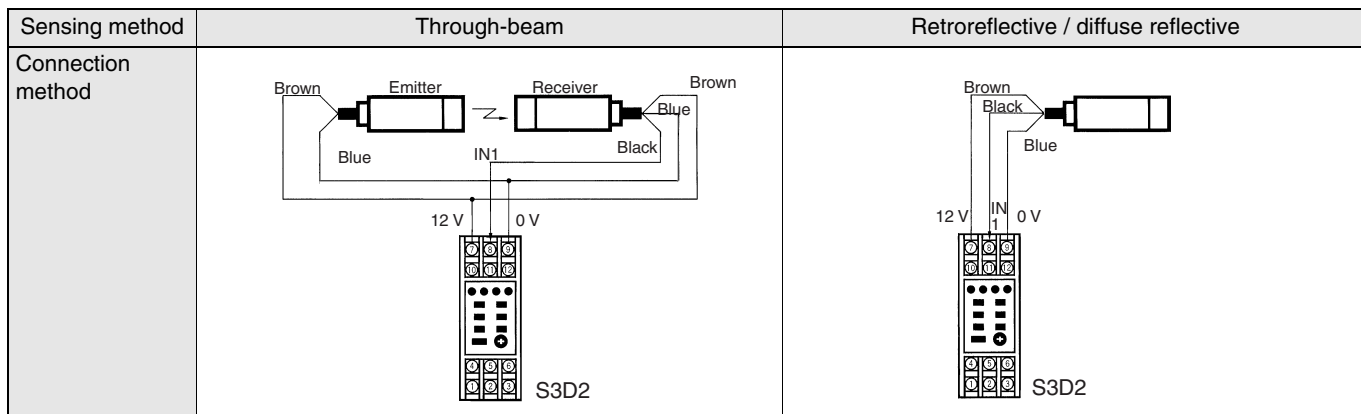

Plug (for E3S-A with connector)

Internal Connection

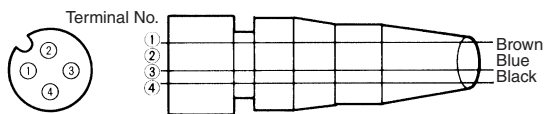

Item	Color of cord	Connection pin No.	Application
For DC	Brown	1	Power supply (+V)
	Black	4	Output
	Blue	3	Power supply (-V)

Note: Pin No. 2 and 4 are connected internally.

External connection

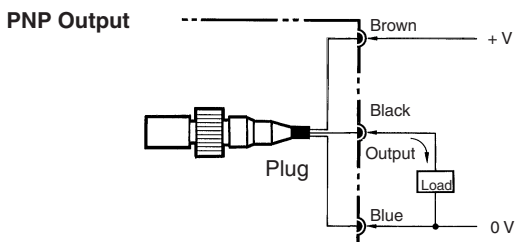
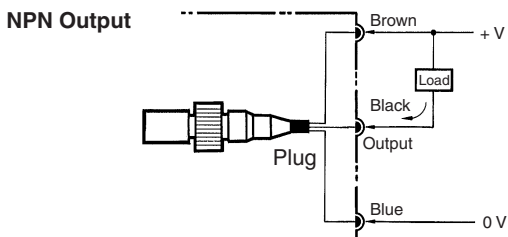

Tightening Plug

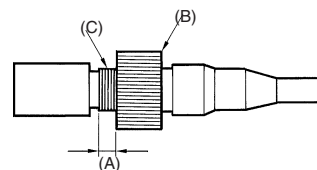

Turn part B by hand (do not use a pliers or the plug will be damaged) and tighten it with part C so that length A is nearly zero. Part B must be tightened properly with part C, or otherwise part B could be loosen by vibration and the sensor will not maintain the specified enclosure ratings.

Note: Use the spacer (sold together) to mount the photoelectric sensor with or without the enclosed mounting bracket (refer to Dimensions (page A-244)).

Precautions

The supplied voltage must be within the rated voltage range. Unregulated full-or half-wave rectifiers must not be used as power supplies.

If the input/output lines of the photoelectric sensor are placed in the same conduit or duct as power lines or high-voltage lines, the photoelectric sensor could be induced to malfunction, or even be damaged, by electrical noise. Either separate the wiring, or use shielded lines as input/output lines to the photoelectric sensor.

Do not use a hammer to hit the amplifier when mounting or the amplifier will loose watertightness.

Note the following when using the E39-R3, E39-RSA, or E39-RSB reflector (tape):

1. Before applying adhesive tape to the reflector, make sure that the reflector is free from oil or dust, or otherwise the adhesive tape will not stick to the reflector properly.
2. Do not cut the reflector or the reflector will loose watertightness.
3. Do not press the reflector with a metal object or a nail, or otherwise the reflector will not function properly.

Position of Optical Axis of Through-beam Model

Unlike conventional through-beam models, the E3S Through-beam Photoelectric Sensor incorporates 2 lenses. But the lens actually in use is the one marked with an arrow indicating the position of the optical axis. When using a slit, attach it to the lens marked with the arrow.

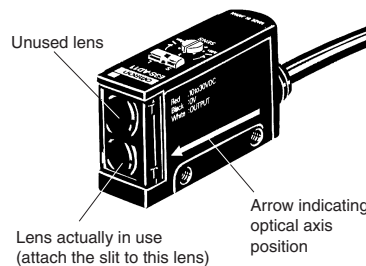

Position of Arrow Indicating Optical Axis

Model	Position of lens in use
E3S-A (vertical)	Top
E3S-A (horizontal)	Bottom

Adjustor Cap

In order to prevent the sensitivity or OFF-delay time that has been set from changing accidentally enclosed, cover the adjustors with the adjustor cap (enclosed).

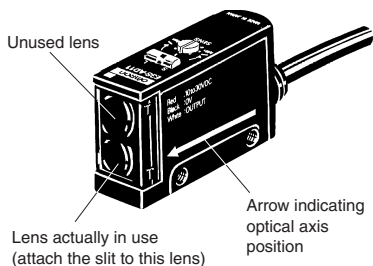

Mutual Interference Filter (E39-E6/-E8)

A set of 4 filters are sold together for two through-beam models (for 2 each of emitters and receivers).

For mounting, refer to the figure of the slit for the E3S-A Photoelectric Sensor.

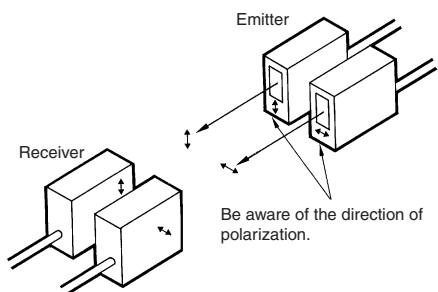

The arrow printed on the cover indicates the direction of polarization. By attaching the filters opposite to each other in polarization to the emitters and the receivers (refer to the figure) in rows, mutual interference can be prevented (in any case, the filter attached to an emitter and to the corresponding receiver must be the same in direction of polarization or the photoelectric sensor will not function).

Mounting Bracket

The direction of the optical axis coincides with the mounting direction of the E3S when the mounting screw is inserted into the lock hole of the mounting bracket. Unlike conventional photoelectric sensors, if the sensing object (or the retroreflector in the case of a through-beam sensor) is in the mounting direction of the photoelectric sensor, the object is detected with the incident light without the time-consuming adjustment of the optical axis (but if the mounting surface is not flat, the adjustment of the optical axis may still be required).

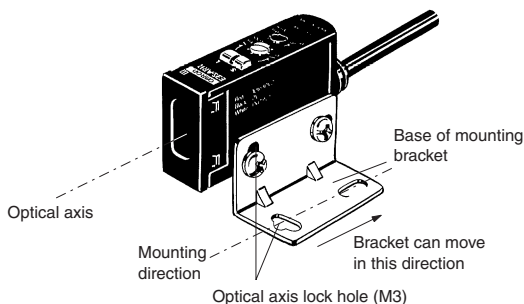

Note: The maximum tightening torque applied to the screw is 5.5 kgf x cm (0.53 N x m).

Installation of Accessories

Sensitivity Adjustor Knob (Attachment)

To temporarily use the knob to adjust the sensitivity of the photoelectric sensor, insert side A into the shaft of the sensitivity adjustor.

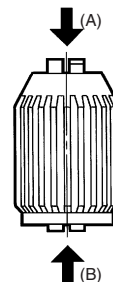

To permanently use the knob to adjust the sensitivity of the photoelectric sensor, insert side B into the shaft (the knob cannot be removed if once side B is inserted into the shaft).

Slit (E39-S46 Order Separately) for E3S-A

Use the rubber attachment with the metal cover if a slit width of 2 mm is required. Insert the 0.5- or 1-mm slit between the metal cover and rubber attachment if a slit width of 0.5 or 1 mm is desired. These slits fit into the rubber attachment.

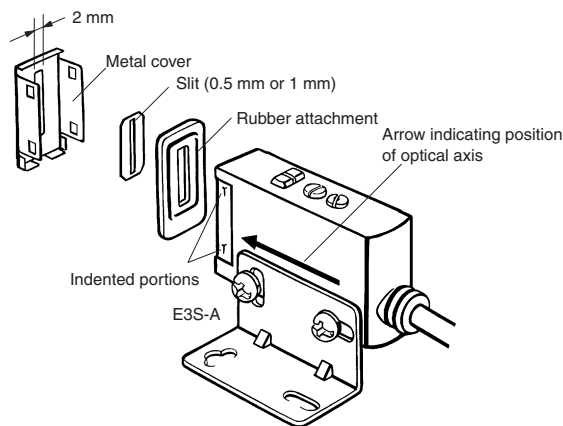

Note: Apply the slit to the lens of the photoelectric sensor marked with an arrow indicating the position of the optical axis (apply it to the bottom lens of horizontal sensors and the top lens of vertical sensors).

Optical Axis Reflector (E39-R5 Order Separately)

Use this attachment when the set distance is long and adjustment is mechanically difficult with a sensing object.

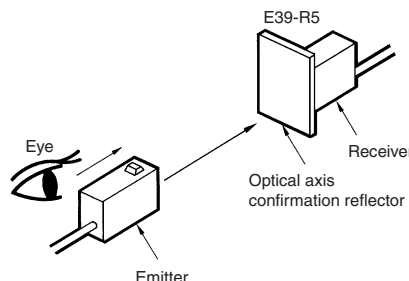

Attach the reflector to the receiver (refer to the figure).

Look at the reflector from right behind the emitter. The reflector should be bright with red light when the optical beam strikes the reflector. If the emitter has a turbo function, the reflector looks brighter with the function switched on.

When the reflector is removed, the light beam strikes the receiver.

ALL DIMENSIONS SHOWN ARE IN MILLIMETERS.

To convert millimeters into inches, multiply by 0.03937. To convert grams into ounces, multiply by 0.03527.

Cat. No.E220-E2-04-X

In the interest of product improvement, specifications are subject to change without notice.



SCATTERGOOD & JOHNSON LTD

ELECTRICAL ENGINEERING & FLUID CONTROL DISTRIBUTORS

Est.1899

At Scattergood & Johnson Ltd, we pride ourselves on being a technical distributor to specialist industries.

Working with a range of quality product suppliers across a number of specialist markets, we are not your average 'box shifter' - we are your technical and supply chain partner.

We fully support every product we sell - for free! Our internal team and external sales engineers can answer any product or application question, no matter the complexity.

Backing up this technical ability is a range of 50,000+ products available from stock for nationwide next day delivery (same day if required!), or you can collect what you need from any of our trade counters around the UK.

Select your specialist interest below to learn more about how we can help.

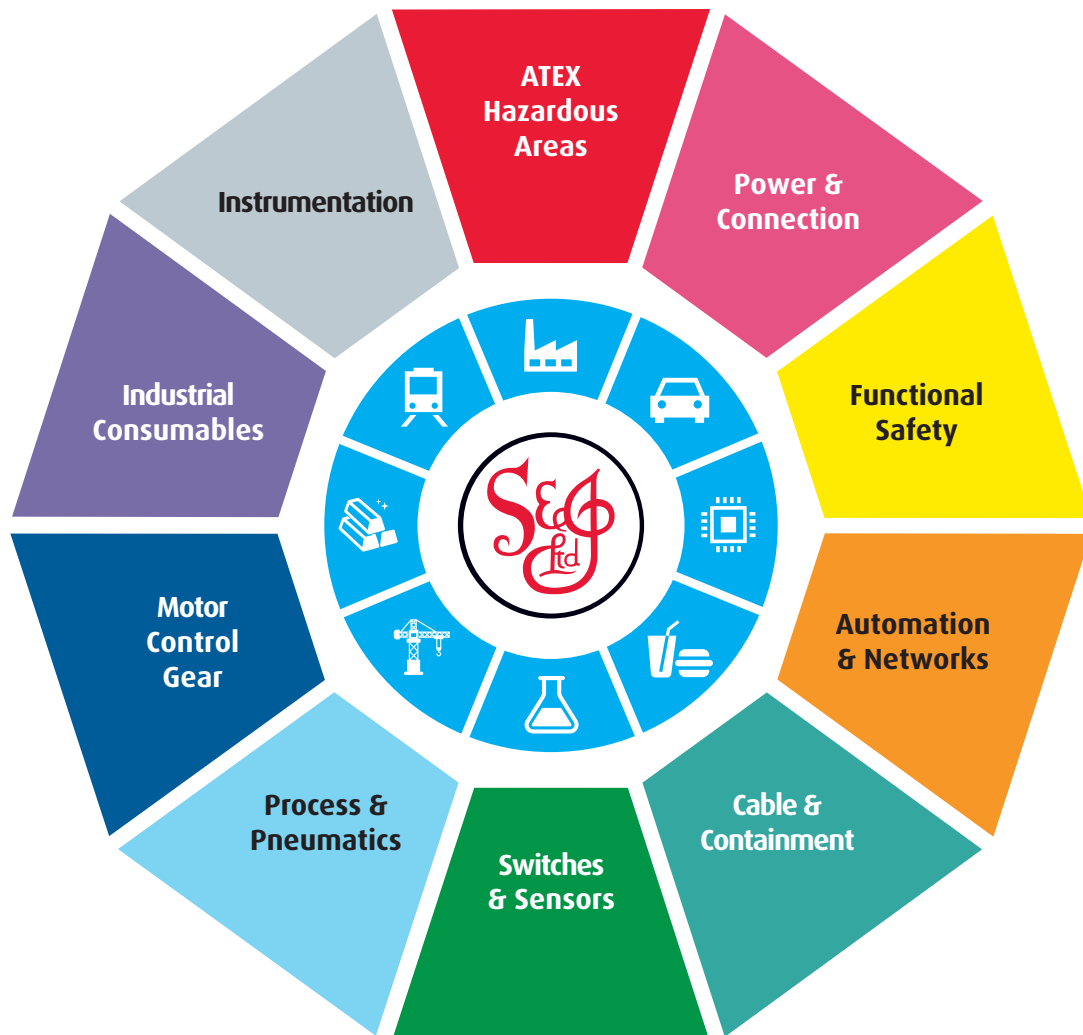

Online, In Branch and On the Road - Scattergood & Johnson Ltd, there when you need us.

www.scatts.co.uk