

Photoelectric switch with built-in amplifier (long distance) in plastic housing

E3G

Retroreflective Models

- Sensing Distance of 10 m, with polarized light to detect shiny objects.
- Operation stability monitored by the stability indicator.

Distance-setting Models

- Distance setting models with a long 2 m sensing distance incorporate a teaching function.
- Set sensing area (zone setting) function allows detection of shiny objects with uneven surface.

Common Features

- Meets IEC IP67 requirements.
- M12 rotary connector, pre-wired or terminal block connection



Features

Retroreflective Models

Though the Size Is Compact, the Sensing Distance Is as Long as 10m.

Replace the conventional through-beam model with the retroreflective model for saving wiring and installation space.

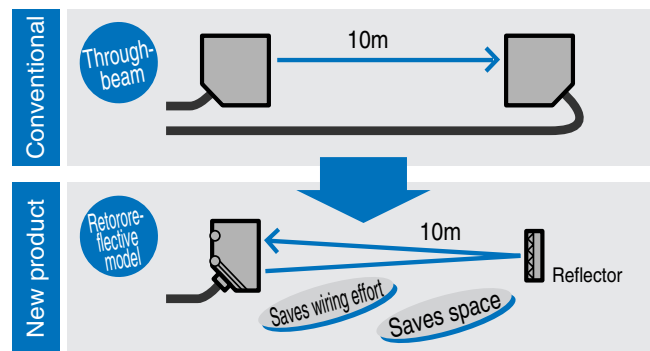

Easy monitoring of Operation stability by means of stability indicator.



Distance-setting

Distance-setting Models with a Long 2-m Sensing Distance Incorporate a Teaching Function

Sensitivity adjustment without being influenced by background objects is possible by simply pressing a button. Useful for teaching without a sensing object.

Easy Optimum Sensing Distance Adjustments

Teaching with and without a sensing object ensures highly accurate detection without influence from the background.

Without sensing object

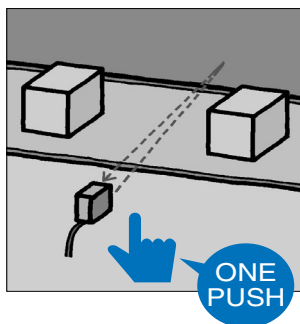

With sensing object

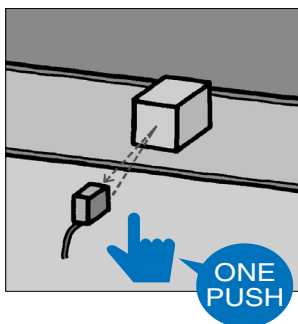

Zone Setting Function

Effective for detecting glossy objects, which were difficult to detect with conventional sensors. (D-ON)

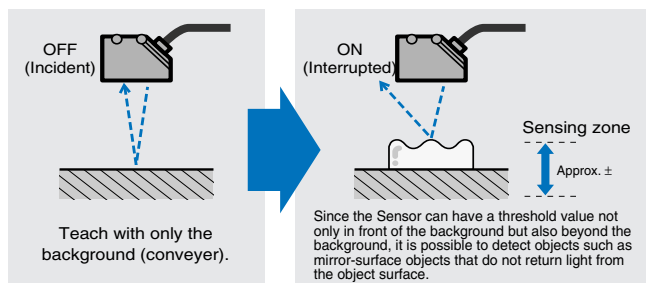

General

Select either transistor (NPN/PNP selectable) or relay output. Three connection methods (plus a model with a timer function). Select either a DC power supply or a variable power supply: 24 V to 240 VAC or 12 to 240 VDC).

IEC Standard IP67 Water Proofing



M12 Rotary Connector Available on Models with DC Power Supplies



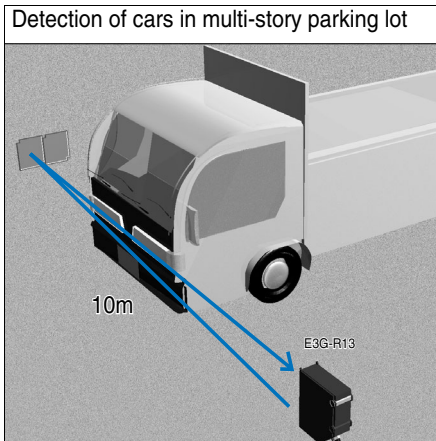
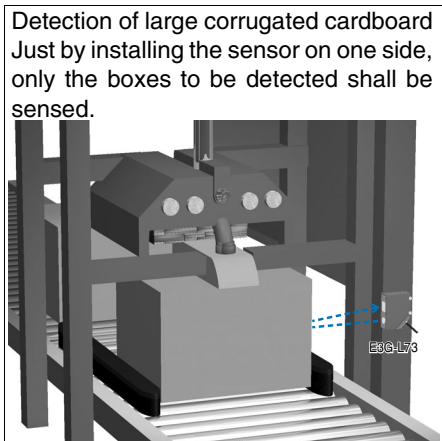
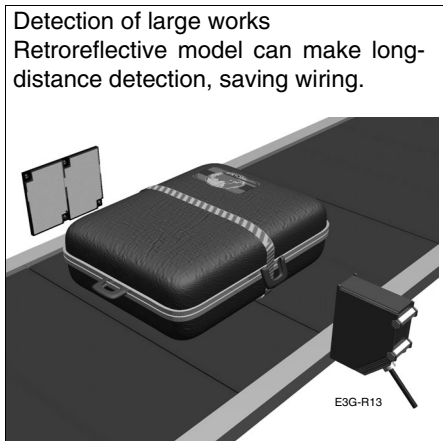

Application



Ordering Information

Sensors

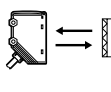
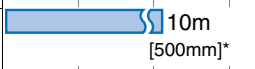
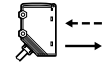
 Red light  Infrared light

Sensor type	Shape	Connection method	Sensing distance	Timer function	Model	
					NPN/PNP selector	Relay contact output
Retroreflec- tive Models (with M.S.R. Function)		Pre-wired		---	E3G-R13-G	---
		Connector type			E3G-R17-G	
		Terminal block			---	E3G-MR19-G E3G-MR19T-G
Distance- setting		Pre-wired	White paper 300 × 300 mm 	---	E3G-L73	---
		Connector type			E3G-L77	
		Terminal block			---	E3G-ML79-G E3G-ML79T-G

* Values in parentheses indicate the minimum required distance between the sensor and reflector.

Accessories (Order Separately)

Reflectors

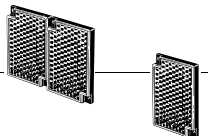



Shape	Sensing distance (typical)	Model	Quantity	Remarks
	10 m (500 mm) *	E39-R2	1	---
	6 m (100 mm) *	E39-R1S	1	---

* Values in parentheses indicate the minimum required distance between the sensor and reflector.

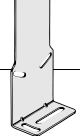

Terminal Protection Cover for Side-pullout Cable

Shape	Model	Quantity	Applicable type	Remarks
	E39-L129-G	1	E3G-MR19(T)-G E3G-ML79(T)-G	Provided with rubber bushing and cap for pullout prevention in horizontal direction

Mounting Brackets

Shape	Model	Quantity	Applicable type	Remarks
	E39-L131	1	E3G-R1□ E3G-L7□	---
	E39-L132	1		Rear-mounting use
	E39-L135	1	E3G-MR19(T)-G E3G-ML79(T)-G	Cable pulled out downwards
	E39-L136	1		---

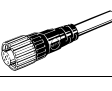
Sensor I/O Connectors

Cable	Shape	Cable length		Model
Standard cable	Straight 	2 m	3-wire type	XS2F-D421-DC0-A
		5 m		XS2F-D421-GC0-A
	L-shaped 	2 m		XS2F-D422-DC0-A
		5 m		XS2F-D422-GC0-A

Rating/Performance

Sensor type		Retroreflective Models (M.S.R. function)				Distance-setting			
Item	Model	E3G-R13-G	E3G-R17-G	E3G-MR19-G	E3G-MR19T-G	E3G-L73	E3G-L77	E3G-ML79-G	E3G-ML79T-G
Sensing distance		10 m (500 mm) * (When using the E39-R2)				0.2 to 2 m (White paper 300 x 300 mm)			
Setting distance		---				0.5 to 1.2 m (White paper 300 x 300 mm)			
Standard sensing object		Opaque: 80 dia. min.				---			
Hysteresis (typical)		---				10% of setting distance			
Directional angle		Sensor: 1° to 5°				---			
Reflectivity characteristics (black/white error)		---				±10% max. (At detection distance of 1m)			
Light source (wave length)		Red LED (700 nm)				Infrared LED (860 nm)			
Spot size		---				70 mm dia. max. (At detection distance of 1m)			
Power supply voltage		10 to 30 VDC [Ripple (p-p) 10% included]		12 to 240 VDC ±10% ripple (p-p) : 10% max. 24 to 240 VAC ±10% 50/60 Hz		10 to 30 VDC (Ripple (p-p) 10% included)		12 to 240 VDC ±10% ripple (p-p) : 10% max. 24 to 240 VAC ±10% 50/60 Hz	
Current/Power consumption		50 mA max.		2 W max.		60 mA max.		2 W max.	
Control output		Load supply voltage 30 VDC max., load current 100 mA max. (residual voltage NPN output: 1.2 V max., PNP output: 2 V max.) Open collector output type (NPN/PNP output switch selectable) L-ON/D-ON switch selectable		Relay output: Switch-over contact 250 VAC 3A (cos =1) max. 30 VDC 3A max. L-ON/D-ON switch selectable		Load supply voltage 30 VDC max., load current 100 mA max. (residual voltage NPN output: 1.2 V max., PNP output: 2 V max.) Open collector output type (NPN/PNP output switch selectable) L-ON/D-ON switch selectable		Relay output: Switch-over contact 250 VAC 3A (cos =1) max. 30 VDC 3A max. L-ON/D-ON switch selectable	
Life expectancy (relay output)	Mechanical	---		50,000,000 operations min. (switching frequency: 18,000 operations/h)		---		50,000,000 operations min. (switching frequency: 18,000 operations/h)	
	Electrical	---		100,000 operations min. (switching frequency: 1,800 operations/h)		---		100,000 operations min. (switching frequency: 1,800 operations/h)	
Protective circuits		Reverse polarity protection, output short-circuit protection, mutual interference prevention		Mutual interference prevention function		Reverse polarity protection, output short-circuit protection, mutual interference prevention		Mutual interference prevention function	
Response time		Operation/reset: 1 ms each		Operation/reset: 30 ms each		Operation/reset: 5 ms each		Operation/reset: 30 ms each	
Sensitivity adjustment		One-turn adjuster				Teaching method (NORMAL mode/ZONE mode)			
Timer function		---		ON delay/ OFF delay 0 to 5 s (Adjuster variable system)		---		ON delay/ OFF delay 0 to 5 s (Adjuster variable system)	
Ambient illuminance		Incandescent lamp: 3,000 lux max. Sunlight 10,000 lux max.							
Ambient temperature		Operating: -25°C to 55°C, Storage: -30°C to 70°C (with no icing or condensation)							
Ambient humidity		Operating: 35% to 85%RH, Storage: 35% to 95%RH (with no condensation)							
Insulation resistance		20 M min. at 500 VDC							
Dielectric strength		1,000 VAC at 50/60 Hz for 1 minute		2,000 VAC at 50/60 Hz for 1 minute		1,000 VAC at 50/60 Hz for 1 minute		2,000 VAC at 50/60 Hz for 1 minute	
Vibration resistance		Destruction: 10 to 55 Hz, 1.5 mm double amplitude for 2 hours each in X, Y, and Z directions							

* Values in parentheses indicate the minimum required distance between the sensor and reflector.

Sensor type		Retroreflective Models (M.S.R. function)				Distance-setting			
Item	Model	E3G-R13-G	E3G-R17-G	E3G-MR19-G	E3G-MR19T-G	E3G-L73	E3G-L77	E3G-ML79-G	E3G-ML79T-G
Shock resistance		500 m/s ² 3 times in each of X, Y and Z directions							
Protective structure		IEC 60529 IP67 (with Protective Cover attached)							
Connection method		Pre-wired (standard length: 2 m)	M12 Connector	Terminal block		Pre-wired (standard length: 2 m)	M12 Connector	Terminal block	
Weight (Packed state)		Approx. 150 g	Approx. 50 g	Approx. 150 g			Approx. 50 g	Approx. 150 g	
Material	Case	PBT (polybutylene terephthalate)							
	Lens	Acrylics (PMMA)							
	Mounting Brackets	Stainless steel (SUS304)							
Accessories		Instruction sheet, and screwdriver for adjustment				Instruction sheet			

Output Circuit Diagram

NPN output

Model	Operating status of output transistor	Timing chart	Mode selection switch	Output circuit
E3G-R13-G E3G-R17-G E3G-L73 E3G-L77	Light ON		L ON (LIGHT ON)	<p>* Set the NPN or PNP selector to NPN</p> <p>Connector Pin Arrangement</p> <p>Note: Terminal 2 is not used.</p>
	Dark ON		D ON (DARK ON)	

PNP output

Model	Operating status of output transistor	Timing chart	Mode selection switch	Output circuit
E3G-R13-G E3G-R17-G E3G-L73 E3G-L77	Light ON		L ON (LIGHT ON)	<p>* Set the NPN or PNP selector to PNP</p> <p>Connector Pin Arrangement</p> <p>Note: Terminal 2 is not used.</p>
	Dark ON		D ON (DARK ON)	

Relay contact output

Timer function	Model	Timing chart	Mode selection switch	Output circuit
None	E3G-MR19-G E3G-ML79-G		L ON (LIGHT ON)	
			D ON (DARK ON)	
ON or OFF delay 0 to 5 s (adjustable)	E3G-MR19T-G E3G-ML79T-G		L ON (LIGHT ON)	
			D ON (DARK ON)	

* For ON and OFF, delay timers vary independently.

Note: Td1, Td2: Delay time (0 to 5 s), T1: Any period longer than delay time, T2: Any period shorter than delay time

Connectors (Sensor I/O connectors)

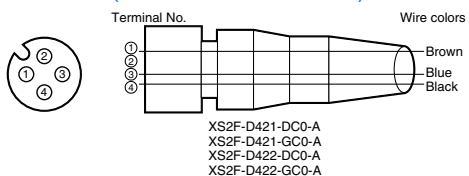

Class	Wire, outer jacket color	Connector pin No.	Application
For DC	Brown	①	Power supply (+V)
	-	②	-
	Blue	③	Power supply (0 V)
	Black	④	Output

Note: Pin 2 is not used.

Characteristic data (typical)

E3G-R/MR Retroreflective Models

Operating Range

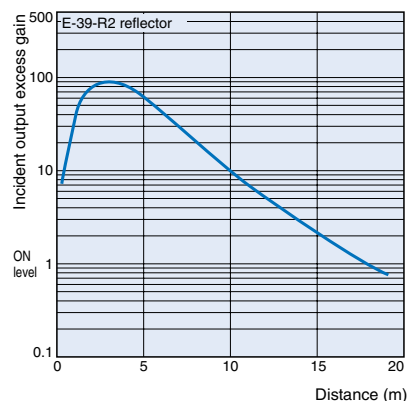

E3G-L/ML Distance-setting Models

Spot Diameter vs. Sensing Distance

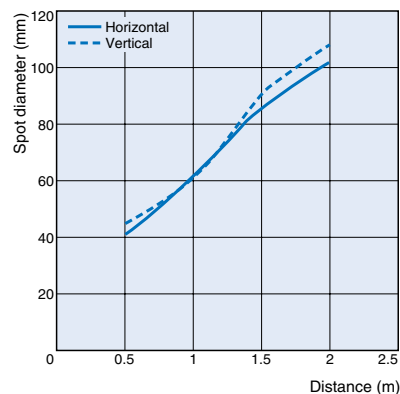

Sensing Zone (in NORMAL mode)

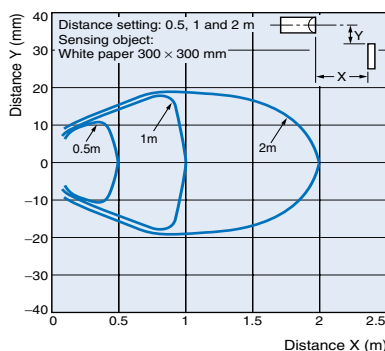

Sensing Zone in ZONE Mode

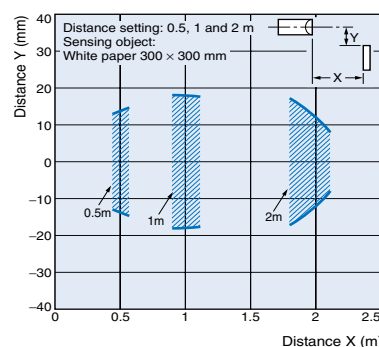

Sensing Object Size vs. Setting Distance

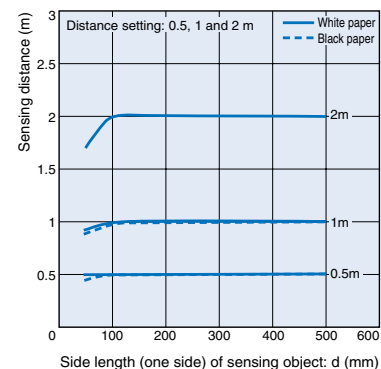

Sensing Object Angle Characteristics (Up and Down)

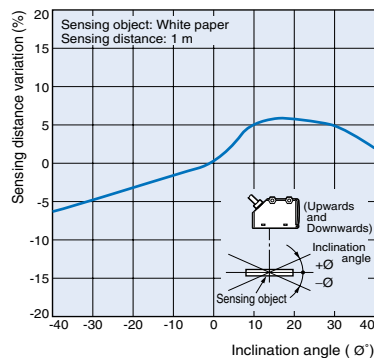

Sensing Object Angle (Left and Right)

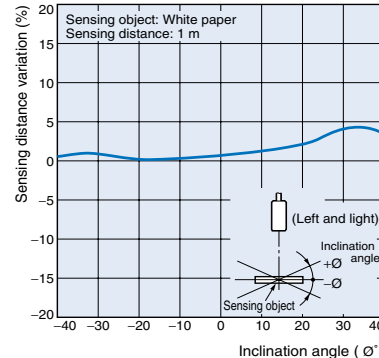

Close-range Characteristics

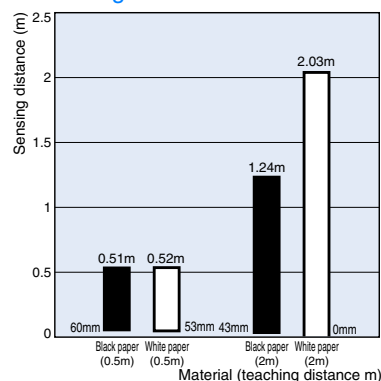

Nomenclature

Retroreflective Models

E3G-R13-G (Pre-wired model)

E3G-R17-G (Connector model)

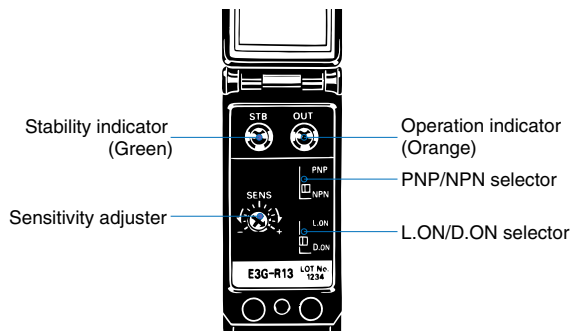

Distance-setting

E3G-L73 (Pre-wired model)

E3G-L77 (Connector model)

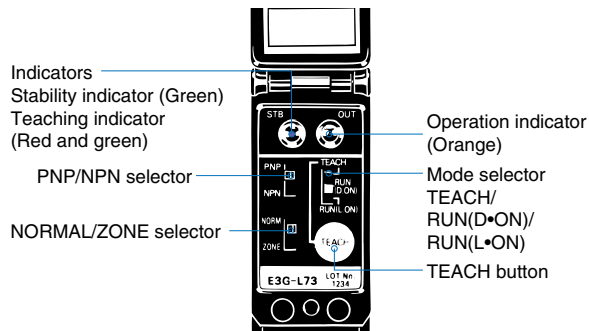

E3G-MR19-G (Terminal Block Model)

E3G-MR19T-G (Terminal Block Model with Timer)

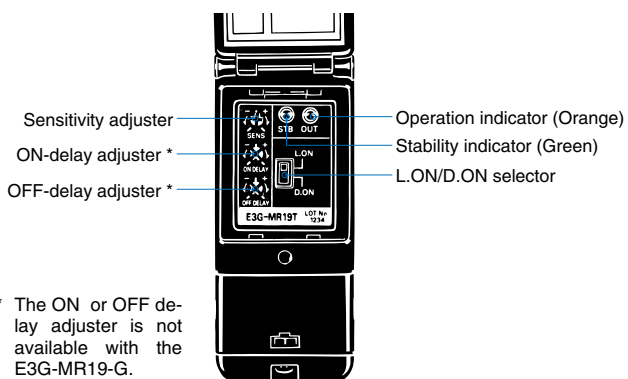

* The ON or OFF delay adjuster is not available with the E3G-MR19-G.

E3G-ML79-G (Terminal Block Model)

E3G-ML79T-G (Terminal Block Model with Timer)

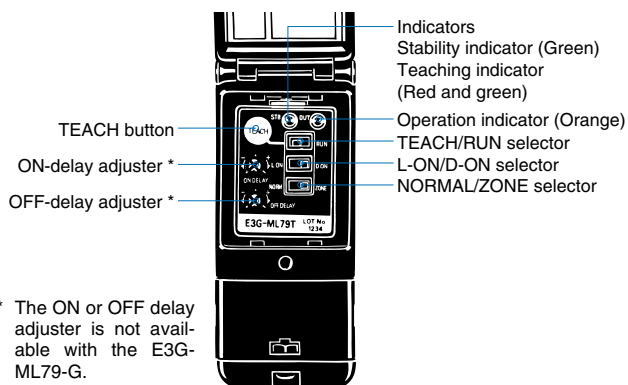

* The ON or OFF delay adjuster is not available with the E3G-ML79-G.

Operation

E3G-L/ML

Adjustment Steps

Proce- dure	Operation
1	Install, wire, and turn on the Sensor.
2	Perform distance setting (teaching). Refer to "Distance Setting (Teaching)".
3	Check that the mode selector is set to RUN.

Distance Setting (Teaching)

Select the most appropriate teaching method in reference to the following descriptions.

Application	Teaching without sensing objects (i.e., Teaching the background).	Setting a threshold in the middle between the background and sensing object for operation.	Detection of glossy objects in front of the background.	Setting the maximum sensing distance of the Sensor.
Teaching	Normal one-point teaching	Normal two-point teaching	Zone teaching	Maximum distance setting (in normal mode)
Setting method	Press the TEACH button with the background object.	Press the TEACH button with the background object.	Press the TEACH button with the background object (conveyor, etc.).	Press the TEACH button for longer than three seconds.
Set threshold	Threshold (a) is set to a distance in front of the background of 20% of the background distance.	Threshold (a) is set approximately in the middle between the background and sensing object.	Thresholds (a and b) are set in the sensing distance on condition that the difference between these thresholds is approximately 10% of the whole sensing distance.	The threshold is set in such manner that the stability indicator will turn ON at approximately 2 m if the sensing object is white paper.
Output ON range	The output is ON between the Sensor and La.	The output is ON between the Sensor and La.	The output is ON between La and Lb.	The output is ON whenever the sensing object is located between the Sensor and at a distance of 2.2 m.

La: Distance equivalent to threshold (a)

Lb: Distance equivalent to threshold (b)

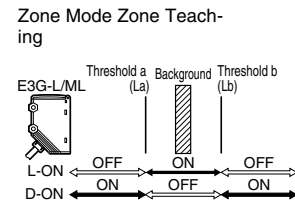
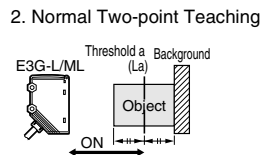
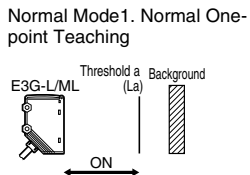

Normal one-point teaching

Proce- dure	Operation
1	Set the mode selector to TEACH .
2	Set the NORMAL/ZONE mode selector to NORMAL .
3	Press the TEACH button with the background. The teaching indicator (red) will turn ON.
4	Set the mode selector to RUN . (Set to L-ON or D-ON mode.)

Note: Perform normal one-point teaching with the background.

Normal two-point teaching

Proce- dure	Operation
1	Set the mode selector to TEACH .
2	Set the NORMAL/ZONE mode selector to NORMAL .
3	Press the TEACH button with a sensing object. The teaching indicator (red) will turn ON.

Proce- dure	Operation
4	Move the sensing object and press the TEACH button with the background. If the teaching is successful, the teaching indicator (green) will turn ON. If the teaching is not successful, the teaching indicator (red) will flash.
5	When the teaching is successful, the setting is complete. Set the mode selector to RUN . (Use the operation mode selector to set L-ON/D-ON.) When the teaching is not successful, change the work position and setting distance again, and restart the setting from step "3".

Zone teaching

Pro- ce- dure	Operation
1	Set the mode selector to TEACH .
2	Set the NORMAL/ZONE mode selector to ZONE .
3	Press the TEACH button with the background. The teaching indicator (red) will turn ON and the teaching indicator (green) will then turn ON.
4	Set the mode selector to RUN . (Set to L-ON or D-ON mode.)

Note: Perform zone teaching with the background.

Maximum distance setting (in normal mode)

If you want to set the maximum distance of the sensor, set a maximum distance as depicted in the following procedure.

Pro- ce- dure	Operation
1	Set the mode selector to TEACH .
2	Set the NORMAL/ZONE mode selector to NORMAL .
3	Press the TEACH button 3 s or more. The teaching indicator (red) will turn ON. In 3 s, the teaching indicator (green) will turn ON.
4	When the teaching indicator (green) turns ON, the setting is complete. Set the mode selector to RUN . (Set to L-ON/D-ON.)

Precautions

Correct Use

E3G-R/MR

Design

Power Supply

A full-wave rectification power supply can be used with the E3G-MR19(T)-G.

Wiring Considerations

The tensile strength of the cable during operation should not exceed the values shown below.

Model	Tensile strength
E3G-R13-G E3G-MR19(T)-G	50 N max.
E3G-R17-G	10 N max.

● For adjustment

Display

- The following graphs indicate the status of each operation level.
- Set the E3G so that it will work within the stable operation range.

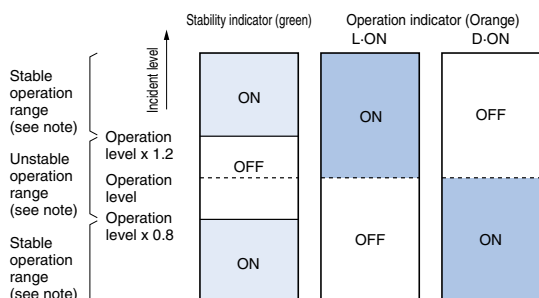

Note: If the operation level is set to the stable operation range, the E3G will operate with the highest reliability and without being influenced by temperature change, voltage fluctuation, dust, or setting change.

E3G-L/ML

Design

Power Supply

A full-wave rectification power supply can be used with the E3G-ML79(T)-G.

Wiring Considerations

The tensile strength of the cable during operation should not exceed the values shown below.

Model	Tensile strength
E3G-L73 E3G-ML79(T)-G	50 N max.
E3G-L77	10 N max.

Miscellaneous

EEPROM Write Error

If a write error occurs (operation indicator flickers) due to power-off, static electricity or other noise in the teaching mode, perform teaching again.

E3G-M□(T)-G

Wiring Considerations

- The cable with an external diameter of 6 to 8 mm is recommended.
- Securely tighten the cover to maintain water resistance and dust resistance. The thread size of the conduit socket is PG 13.5
- Do not tighten with the cable caught by the terminal protection cover. Otherwise, the water-resistant structure and like cannot be maintained.

(Recommended example)

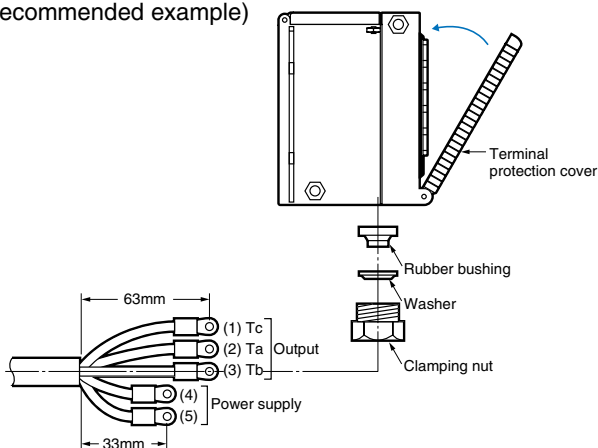

- Changing to Side-pullout Cable from Vertical-pullout Cable

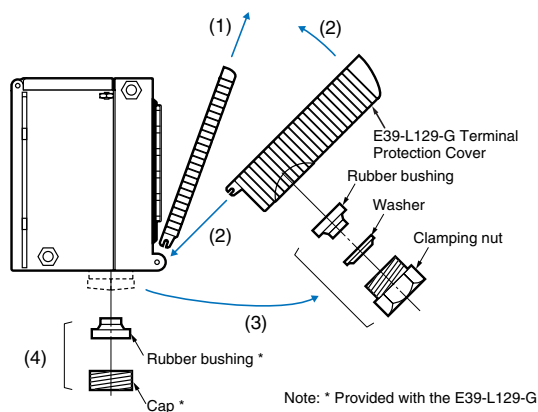

Note: * Provided with the E39-L129-G

Pro- ce- dure	Operation
①	Remove the present cover.
②	Attach the E39-L129-G Terminal Protection Cover for side-pullout cable.
③	Remove the clamping nut, washer, and rubber bushing of the E3G. These are used for the side-pullout cable.
④	Attach the rubber bushing and cap provided with the E39-L129-G to the E3G as replacements.

All E3G Models

Design

Load Relay Contact

If a load is used that will spark when it is turned OFF (e.g. a contactor or valve), the usually closed side may be turned ON before the usually open side is turned OFF or vice versa. If both usually open output and usually closed output are used simultaneously, apply a surge suppressor to the load. (Refer to OMRON's "Switch/Relay/Connector (PCB Product) Catalog" for typical examples of surge suppressors.

Wiring Considerations

Connection/Wiring

The E3G has load short-circuit protection. If load short-circuit or like has occurred, the output turns OFF. Therefore, recheck the wiring and switch power on again. This resets the short-circuit protection circuit. Load short-circuit protection is activated when a current of 2 times or more of the rated load current flows. When using an L load, use the one the inrush current of which is less than 1.2 times of the rated load current.

Mounting

- If Sensors are mounted face-to-face, ensure that no optical axes cross each other. Otherwise, mutual interference may result.
- Be sure to install the Sensor carefully so that the directional angle range of the Sensor will not be directly exposed to intensive light, such as sunlight, fluorescent light, or incandescent light.
- Do not strike the Photoelectric Sensor with a hammer or any other tool during the installation of the Sensor, or the Sensor will lose its water-resistive properties.
- Use M4 screws for Sensor installation.
- For case installation, tighten it to the torque of 1.2 Nm max.

Water Resistance

Tighten the operation cover screws and terminal block cover screws to a torque of 0.3 to 0.5 Nm in order to ensure water resistivity.

Dimensions (Unit: mm)

Sensors

Retroreflective Models

Pre-wired

E3G-R13-G

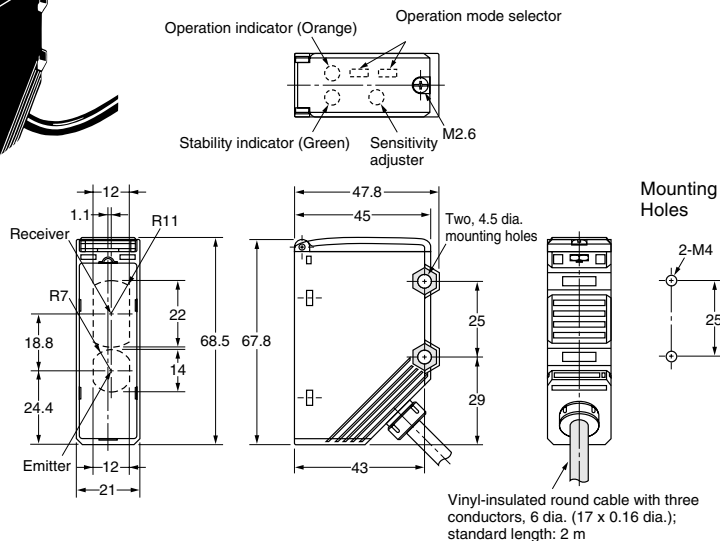
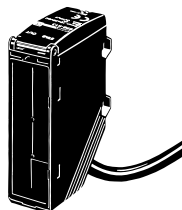

Connector type

E3G-R17-G

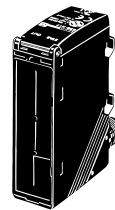

Note: All dimensions other than the ones specified below are the same as the corresponding dimensions of E3G-R13-G.

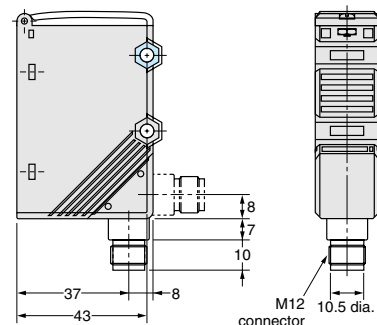

Terminal block

E3G-MR19-G

E3G-MR19T-G

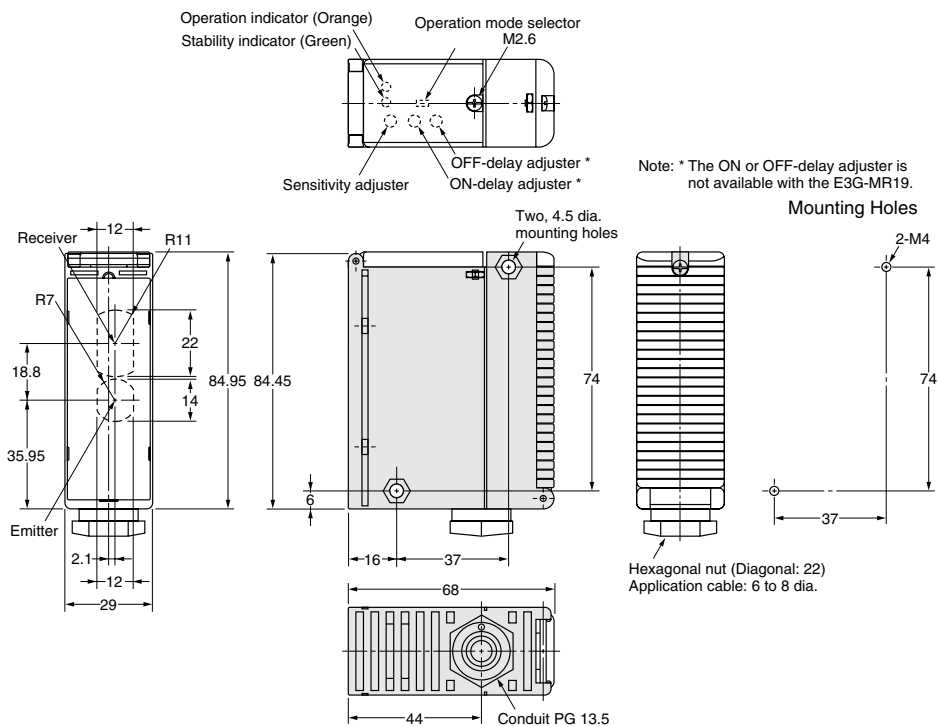
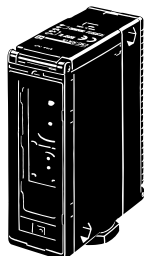

Distance-setting

Pre-wired
E3G-L73

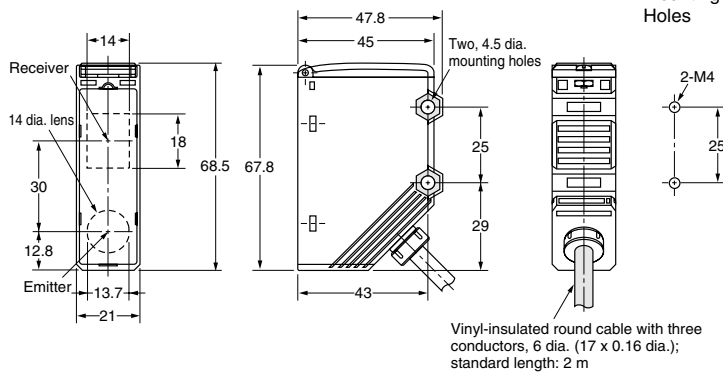
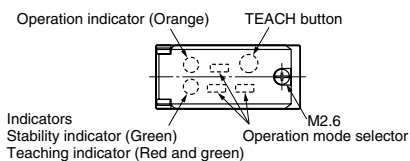
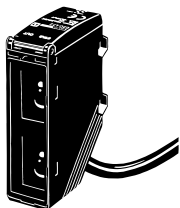

Connector type
E3G-L77



Note: The figures and dimensions not given are the same as those of E3G-L73-G shown on the left.

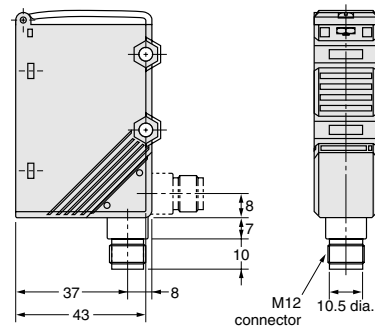

Terminal block
E3G-ML79-G
E3G-ML79T-G

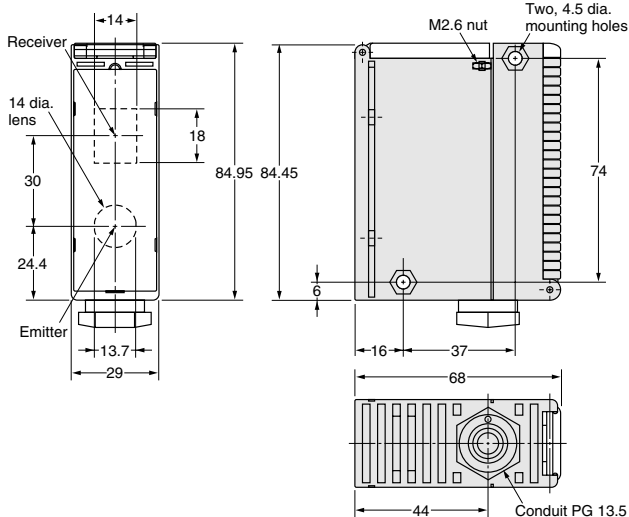
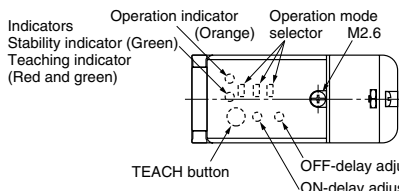
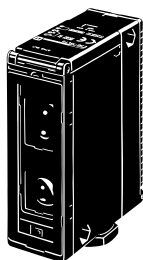

E3G-ML79-G does not equipped ON-delay adjuster and OFF-delay adjuster.

Mounting Holes

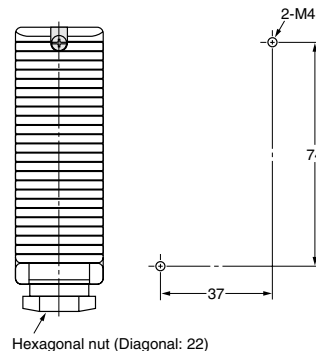

Accessories (Order Separately)

Terminal Protection Cover for Side-pullout Cable

E39-L129-G

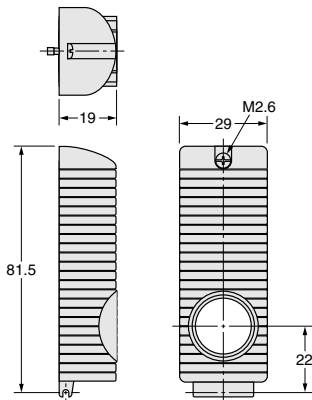

Note: 1 . The cover is provided with a rubber bushing and cap to prevent the cable from being pulled out in vertical direction.

Terminal Protection Cover for Side-pullout Cable (Example of E3G-MR19-G)

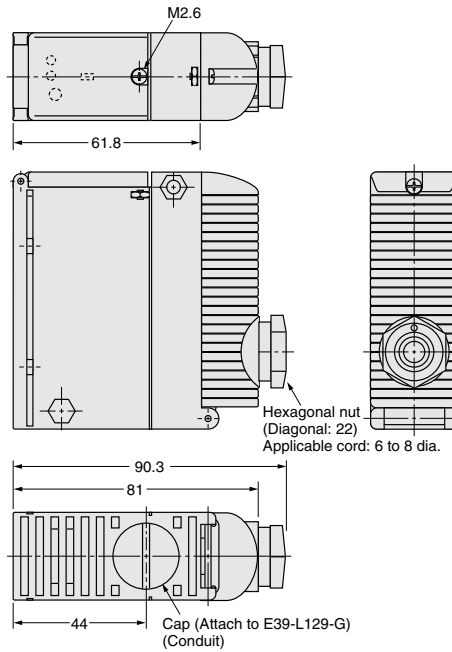

Reflectors and Mounting Brackets

H-3

ALL DIMENSIONS SHOWN ARE IN MILLIMETERS.
 To convert millimeters into inches, multiply by 0.03937. To convert grams into ounces, multiply by 0.03527.



SCATTERGOOD & JOHNSON LTD

ELECTRICAL ENGINEERING & FLUID CONTROL DISTRIBUTORS

Est.1899

At Scattergood & Johnson Ltd, we pride ourselves on being a technical distributor to specialist industries.

Working with a range of quality product suppliers across a number of specialist markets, we are not your average 'box shifter' - we are your technical and supply chain partner.

We fully support every product we sell - for free! Our internal team and external sales engineers can answer any product or application question, no matter the complexity.

Backing up this technical ability is a range of 50,000+ products available from stock for nationwide next day delivery (same day if required!), or you can collect what you need from any of our trade counters around the UK.

Select your specialist interest below to learn more about how we can help.



Online, In Branch and On the Road - Scattergood & Johnson Ltd, there when you need us.

www.scatts.co.uk