

# Miniature Square Photoelectric Sensor in plastic housing

## E3T

- Precision pinpoint LED
- 3.5 mm thin flat shape or 6.6 mm side view shape where space is crucial
- IP67
- Pulse synchronisation for high ambient light immunity
- Models for mounting with M2 or M3 screws



### Features

3.5 mm flat model with background suppression (BGS) with highest repeatability even for differently coloured objects.

#### Minimal black/white error

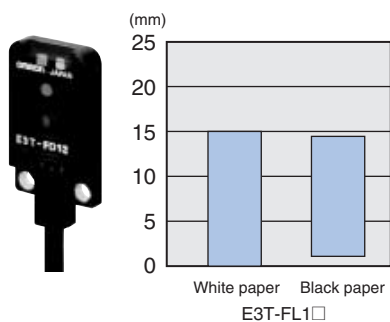

#### Unique light receiving lens shape for high precision alignment



#### New mounting technology for reliable background suppression in 3.5 mm flat housing

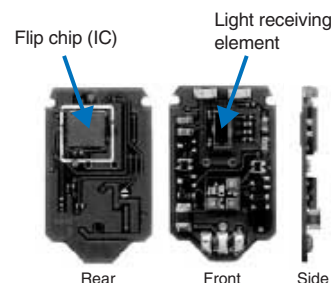

#### Object detection through small holes

- The precision pinpoint LED of the through-beam models provides appropriate sensing distances for very precise and reliable detection even through smallest slits and gaps with e.g. 0.5 mm dia.
- The coaxial optics and the small focal lens of the retro-reflective models allow the detection of small (dia 2 mm) objects or through small holes (dia 2 mm).

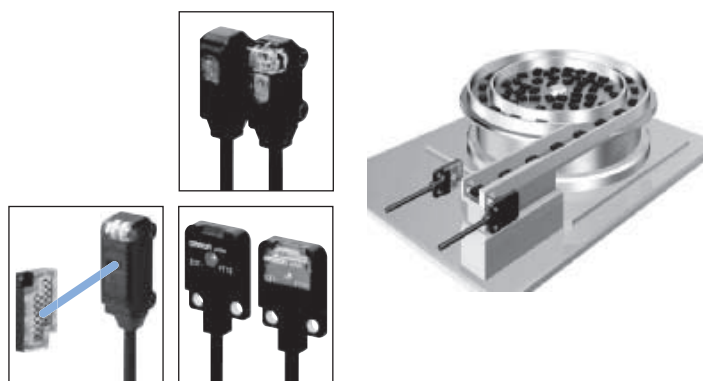

## Application

### E3T-SL limited-reflective models (side view)

- Minimum detection object: 0.15 mm dia.
- Limited-reflective optics reduce the influence of changing backgrounds and surrounding metal for enhanced detection stability.



### E3T-FD Diffuse-reflective Models (Flat)

- Minimum detection object: 0.15 mm dia.
- 3.5 mm thickness for installations with limited space.













### Models with M2 or M3 mounting holes

- space saving M2 screw mounting (screws included)
- standard M3 screw mounting (order screws sets from accessories)

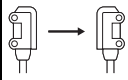

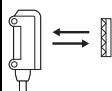
## Ordering Information

### Sensors

Sensor type	Sensing distance	Connection method				Operation mode	Mounting screw size	Order code <sup>*1</sup>		
								NPN output	PNP output	
Through-beam 	2 m	—	—	2 m	For ordering pigtail versions replace '2M' of cable types with: - M1J: M12 with 30 cm cable, - M3J: M8 4-pin with 30 cm cable - M5J: M8 3-pin with 30 cm cable	Light-ON	M2	E3T-ST31 2M	E3T-ST33 2M	
	1 m	Dark-ON	M2	E3T-ST32 2M		E3T-ST34 2M				
		Light-ON	M2	E3T-ST11 2M		E3T-ST13 2M				
			M3	E3T-ST11M 2M		E3T-ST13M 2M				
		Dark-ON	M2	E3T-ST12 2M		E3T-ST14 2M				
			M3	E3T-ST12M 2M		E3T-ST14M 2M				
		300 mm	Light-ON	M2		E3T-ST21 2M	E3T-ST23 2M			
	M3		E3T-ST21M 2M	E3T-ST23M 2M						
	Dark-ON	M2	E3T-ST22 2M	E3T-ST24 2M						
		M3	E3T-ST22M 2M	E3T-ST24M 2M						
	Through-beam 	500 mm	—	—		—	Light-ON	M2	E3T-FT11 2M	E3T-FT13 2M
		300 mm	Dark-ON	M2		E3T-FT12 2M	E3T-FT14 2M			
Light-ON			M2	E3T-FT21 2M		E3T-FT23 2M				
Dark-ON		M2	E3T-FT22 2M	E3T-FT24 2M						
Retro-reflective 	30 to 200 mm <sup>*2</sup> on reflectors/ 10 to 100 mm <sup>*2</sup> on reflective foils	—	—	—		Light-ON	M2	E3T-SR41-C 2M <sup>*3</sup>	E3T-SR43-C 2M <sup>*3</sup>	
	Dark-ON	M2	E3T-SR42-C 2M <sup>*3</sup>	E3T-SR44-C 2M <sup>*3</sup>						
Diffuse-reflective 	5 to 30 mm	—	—	—		Light-ON	M2	E3T-FD11 2M	E3T-FD13 2M	
							M3	E3T-FD11M 2M	E3T-FD13M 2M	
						Dark-ON	M2	E3T-FD12 2M	E3T-FD14 2M	
							M3	E3T-FD12M 2M	E3T-FD14M 2M	
Limited-reflective 	5 to 15 mm	—	—	—		Light-ON	M2	E3T-SL11 2M	E3T-SL13 2M	
	5 to 30 mm						M3	E3T-SL11M 2M	E3T-SL13M 2M	
						Dark-ON	M2	E3T-SL12 2M	E3T-SL14 2M	
							M3	E3T-SL12M 2M	E3T-SL14M 2M	
					Light-ON	M2	E3T-SL21 2M	E3T-SL23 2M		
						M3	E3T-SL21M 2M	E3T-SL23M 2M		
					Dark-ON	M2	E3T-SL22 2M	E3T-SL24 2M		
	M3					E3T-SL22M 2M	E3T-SL24M 2M			
Diffuse-reflective (background suppression) 	1 to 15 mm	—	—	—	Light-ON	M2	E3T-FL11 2M	E3T-FL13 2M		
	1 to 30 mm				Dark-ON	M2	E3T-FL12 2M	E3T-FL14 2M		
					Light-ON	M2	E3T-FL21 2M	E3T-FL23 2M		
	Dark-ON				M2	E3T-FL22 2M	E3T-FL24 2M			

\*1. For pre-wired models with robotic cables add '-R' to the order code (example: E3T-FT21R 2M)

\*2. The distances are measured with reflector E39-R4 and reflective foil E39-R37-CA. For applications with shorter distances between the sensor and the reflector contact your OMRON representative.

\*3. Order reflector separately. Models with included reflectors are available.

## Accessories (Order Separately)





## Slits

Minimum detectable object (typical)	Sensing distance	Applicable sensor	Quantity	Order code	
0.5mm dia	200 mm	E3T-ST3	2	E39-S63	
	100 mm	E3T-ST1			
	30 mm	E3T-ST2			
1mm dia	600 mm	E3T-ST3			
	300 mm	E3T-ST1			
	100 mm	E3T-ST2			
0.5mm dia	50 mm	E3T-ST1		E39-S64	
	30 mm	E3T-ST2			
1mm dia	100 mm	E3T-ST1			
	50 mm	E3T-ST2			
0.5mm dia	100 mm	E3T-ST1_M			E39-S67A
	30 mm	E3T-ST2_M			
1mm dia	300 mm	E3T-ST1_M	E39-S67B		
	100 mm	E3T-ST2_M			

## Mutual Interference Prevention Filters

Sensing distance	Applicable sensor	Quantity	Order code
300 mm	E3T-ST1_M	4 (two for receivers and two for emitters)	E39-S67B
100 mm	E3T-ST2_M		

## Reflectors







Shape	Type	Sensing distance *1	Minimum detectable object (typical)	Remarks	Order code
	Small reflector	200 mm (30 mm)	2 mm dia	Reflectors E39-_-CA are optimised for operation with E3T-SR4. Please verify the performance when using other reflectors and reflective tapes.	E39-R4
		100 mm (10 mm)			E39-R37-CA
	Tape reflector	100 mm (10 mm)			E39-RS1-CA
		100 mm (10 mm)			E39-RS2-CA
		100 mm (10 mm)			E39-RS3-CA

\*1. Values in parentheses indicate the minimum required distance between the Sensor and Reflector.

## Sensitivity Adjustment Unit

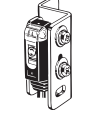
Appearance	Sensing distance (typical)	Quantity	Remarks	Model
	300 to 800 mm	1	Can be used with the E3T-ST1□ Though-beam Models.	E39-E10

## Mounting Brackets

Appearance	Quantity	Remarks	Model
	1	Can be used with the E3T-S□□□ Side-view Models. (A securing nut plate is provided with the Mounting Bracket.)	E39-L116
			E39-L117 for M2 mounting
			E39-L166 for M3 mounting
		Can be used with the E3T-F□□□ Flat Models.	E39-L119
			E39-L120 for M2 mounting
			E39-L167 for M3 mounting
	Spacer for mounting flat sensors with M3 screws	E39-L168	

Note: When using Through-beam models, order one bracket for the Receiver and one for the Emitter.

## Screw Sets

Type	Comment	Applicable sensor	Quantity	Order code
Screw set for M2 side view sensors	Iron Phillips screws (M2×14), Hexagonal nuts, Spring washers, Flat washers	E3T-S	2	E39-L164
Screw set for M2 flat sensors	Iron Phillips screws (M2×8), Hexagonal nuts, Spring washers, Flat washers	E3T-F		E39-L165
SUS Screw set for M2 side view sensors	Stainless steel bolt with hexagonal hole (M2 x 6)	E3T-S		E39-L172
SUS Screw set for M2 flat sensors	Stainless steel bolt with hexagonal hole (M2×12), Hexagonal nuts, Spring washers, Flat washers	E3T-F		E39-L173
SUS Screw set for M3 side view sensors	Stainless steel bolt with hexagonal hole (M3 x 6)	E3T-S_M		E39-L170
SUS Screw set for M3 flat sensors	Stainless steel bolt with hexagonal hole (M3×15), Hexagonal nuts, Spring washers, Flat washers	E3T-F_M		E39-L171

## Rating and Specifications

Item	Through-beam				Retro-reflective		Diffuse-reflective	
	Side-view		Flat		Side-view		Flat	
	NPN	PNP	NPN	PNP	NPN	PNP	NPN	PNP
	E3T-ST1_ E3T-ST2_ E3T-ST3_	E3T-ST1_ E3T-ST2_ E3T-ST3_	E3T-FT1_ E3T-FT2_ E3T-FT3_	E3T-FT1_ E3T-FT2_ E3T-FT3_	E3T-SR41 E3T-SR42	E3T-SR43 E3T-SR44	E3T-FD11 E3T-FD12	E3T-FD13 E3T-FD14
Sensing distance	E3T-ST1□ 1 m E3T-ST2□ 300 mm E3T-ST3□ 2 m	E3T-ST1□ 1 m E3T-ST2□ 300 mm E3T-ST3□ 2 m	E3T-FT1□ 500 mm E3T-FT2□ 300 mm	E3T-FT1□ 500 mm E3T-FT2□ 300 mm	200 mm (30 mm) with E39-R4 <sup>*1</sup> 100 mm (10 mm) with E39-R37-CA <sup>*1</sup>		5 to 30 mm (50 x 50 mm white paper)	
Minimum detectable object (typical)	2 mm dia opaque object (E3T-ST1 and E3T-ST2) 3 mm dia opaque object (E3T-ST3)		1.3 mm dia opaque object		2 mm dia. (sensing distance of 100 mm)		0.15 mm dia. (sensing distance of 10 mm)	
Hysteresis (white paper)	---						6 mm max.	
Directional angle	Emitter: 2° to 20° Receiver: 2° to 70°		Emitter: 3° to 25° Receiver: 3° min.		2° to 20°		---	
Light source (wavelength)	Red LED ("Pin-point" LED) λ = 650 nm							
Power supply voltage	12 to 24 VDC ±10%, ripple (p-p) 10% max.							
Current consumption	Emitter: 10 mA max. Receiver: 20 mA max.				20 mA max.			
Control output	Load power supply voltage: 26.4 VDC max. Load current: 50 mA max. (residual voltage: 2 V max. for load current of 10 to 50 mA, 1 V max. for load current of less than 10 mA) Open collector output Light ON: E3T-□□□1 and E3T-□□□3 Dark ON: E3T-□□□2 and E3T-□□□4							
Protection circuits	Power supply and control output reverse polarity protection Output short-circuit protection				Power supply and control output reverse polarity protection Output short-circuit protection, Mutual interference prevention, surge suppressor		Power supply and control output reverse polarity protection Output short-circuit protection, Mutual interference prevention	
Response time	Operate or reset: 1 ms max.							
Ambient illumination	Incandescent lamp: 5,000 lx max. Sunlight: 10,000 lx max.							
Ambient temperature range	Operating: -25 to 55 °C Storage: -40 to 70 °C (with no icing or condensation)							
Ambient humidity range	Operating: 35% to 85% Storage: 35% to 95% (with no condensation)							
Insulation resistance	20 MΩ min. at 500 VDC							
Dielectric strength	1,000 VAC, 50/60 Hz for 1 min							
Vibration resistance	Destruction: 10 to 2,000 Hz, 1.5 mm double amplitude or 300 m/s <sup>2</sup> for 0.5 hrs each in X, Y, and Z directions							
Shock resistance	Destruction: 1,000 m/s <sup>2</sup> 3 times each in X, Y, and Z directions							
Degree of protection	IP67 (IEC60529)							
Connection method	Pre-wired (standard length: 2 m)							
Weight	Approx. 40 g				Approx. 20 g			
Materials	Case	PBT (polybutylene terephthalate)						
	Display window	Denatured polyarylate						
	Lens	Denatured polyarylate			Methacrylic resin		Denatured polyarylate	
Accessories	Instruction manual, (screw set E39-L164 for E3T-ST (2 sets) and E3T-SR (1 set); screw set E39-L165 for E3T-FT (2 sets) and E3T-FS (1 set). For E3T-_M order screw sets separately)							

\*1. Values in parentheses indicate the minimum required distance between Sensor and Reflector.

Item	Limited-reflective				Diffuse-reflective (background suppression)			
	Side-view				Flat			
	NPN	PNP	NPN	PNP	NPN	PNP	NPN	PNP
	E3T-SL11 E3T-SL12	E3T-SL13 E3T-SL14	E3T-SL21 E3T-SL22	E3T-SL23 E3T-SL24	E3T-FL11 E3T-FL12	E3T-FL13 E3T-FL14	E3T-FL21 E3T-FL22	E3T-FL23 E3T-FL24
Sensing distance	5 to 15 mm (50 x 50 mm white paper)		5 to 30 mm (50 x 50 mm white paper)		1 to 15 mm (50 x 50 mm white paper)		1 to 30 mm (50 x 50 mm white paper)	
Standard sensing object	---							
Minimum detectable object (typical)	0.15 mm dia. (sensing distance of 10 mm)				0.15 mm dia non-glossy object (sensing distance of 10 mm)			
Hysteresis (white paper)	2 mm max.		6 mm max.		0.5 mm max.		2 mm max.	
Black/white error	---						15% max.	
Directional angle	---							
Light source (wavelength)	Red LED ("Pin-point" LED) $\lambda = 650$ nm							
Power supply voltage	12 to 24 VDC $\pm 10\%$ , ripple (p-p) 10% max.							
Current consumption	20 mA max.							
Control output	Load power supply voltage: 26.4 VDC max. Load current: 50 mA max. (residual voltage: 2 V max. for load current of 10 to 50 mA, 1 V max. for load current of less than 10 mA) Open-collector output Light ON: E3T-□□□1 and E3T-□□□3 Dark ON: E3T-□□□2 and E3T-□□□4							
Protection circuits	Power supply and control output reverse polarity protection Output short-circuit protection, Mutual interference prevention							
Response time	Operate or reset: 1 ms max.							
Ambient illumination	Incandescent lamp: 5,000 lx max. Sunlight: 10,000 lx max.							
Ambient temperature range	Operating: -25 to 55 °C Storage: -40 to 70 °C (with no icing or condensation)							
Ambient humidity range	Operating: 35% to 85% Storage: 35% to 95% (with no condensation)							
Insulation resistance	20 M $\Omega$ min. at 500 VDC							
Dielectric strength	1,000 VAC, 50/60 Hz for 1 min							
Vibration resistance	Destruction: 10 to 2,000 Hz, 1.5 mm double amplitude or 300 m/s <sup>2</sup> for 0.5 hrs each in X, Y, and Z directions							
Shock resistance	Destruction: 1,000 m/s <sup>2</sup> 3 times each in X, Y, and Z directions							
Degree of protection	IP67 (IEC60529)							
Connection method	Pre-wired (standard length: 2 m)							
Weight	Approx. 20 g							
Materials	Case	PBT (polybutylene terephthalate)						
	Display window	Denatured polyarylate						
	Lens	Denatured polyarylate						
Accessories	Instruction manual, (screw set E39-L164 for E3T-SL (1 set); screw set E39-L165 for E3T-FL (1 set). For E3T-_M order screw sets separately)							

## Engineering Data (Typical)

### M2-mounting and M3-mounting Sensors

#### Parallel Operating Range

##### Through-beam

##### E3T-ST3□ + E39-S63 Slit

(A Slit is mounted to the Emitter and Receiver.)

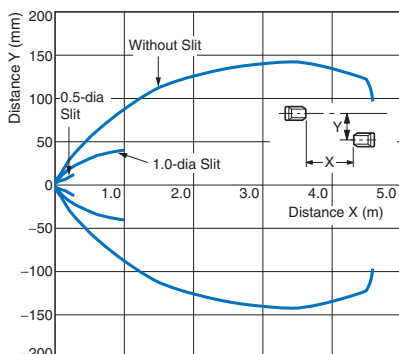

##### E3T-ST1□(M) + E39-S63 Slit (Enlarged graph)

(A Slit is mounted to the Emitter and Receiver.)

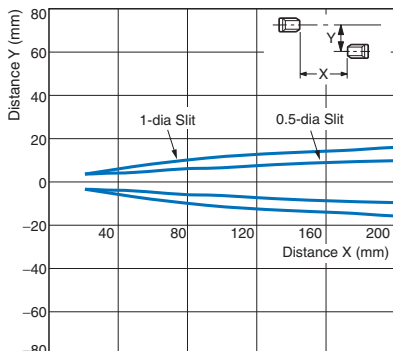

##### E3T-ST2□(M) + E39-S63 Slit

##### E3T-ST□□ + E39-E14 Mutual interference prevention filter

(A Slit is mounted to the Emitter and Receiver.)

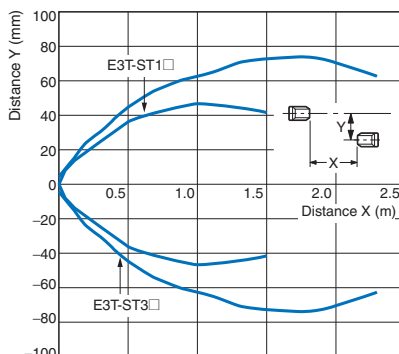

##### E3T-ST2□(M) + E39-S63 Slit

(A Slit is mounted to the Emitter and Receiver.)

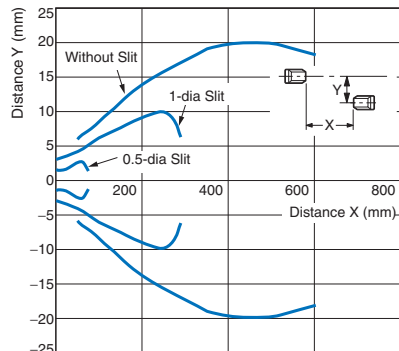

##### E3T-FT2□ + E39-S64 Slit

(A Slit is mounted to the Emitter and Receiver.)

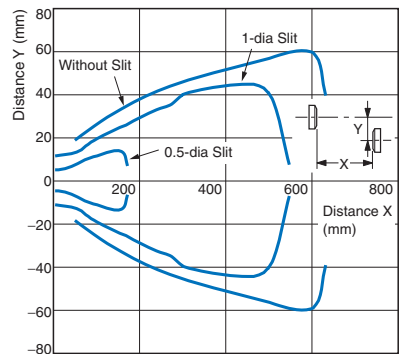

##### E3T-ST1□(M) + E39-S63 Slit

(A Slit is mounted to the Emitter and Receiver.)

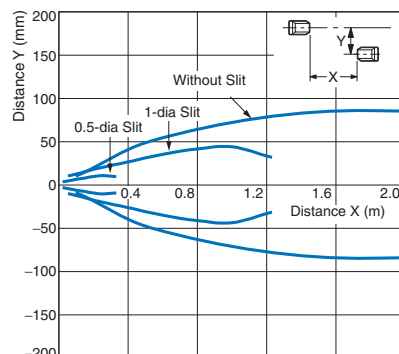

##### E3T-FT1□ + E39-S64 Slit

(A Slit is mounted to the Emitter and Receiver.)

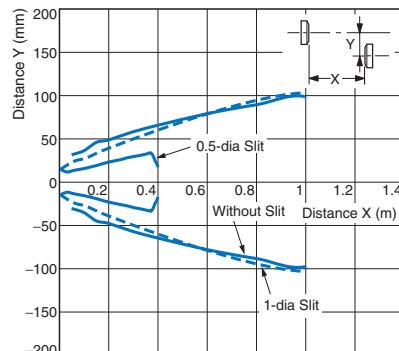

##### Retro-reflective

##### E3T-SR4□

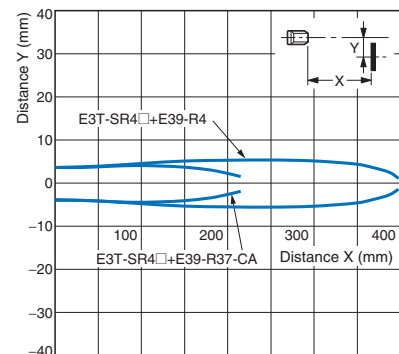

#### Operating Range

##### Diffuse-reflective

##### E3T-FD1□(M)

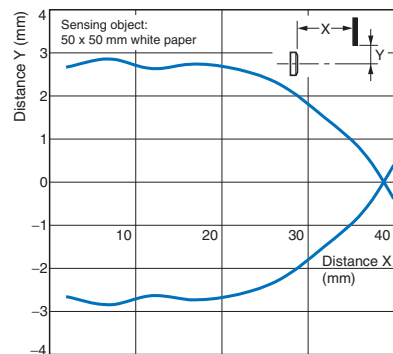

##### Convergent-reflective

##### E3T-SL1□(M)

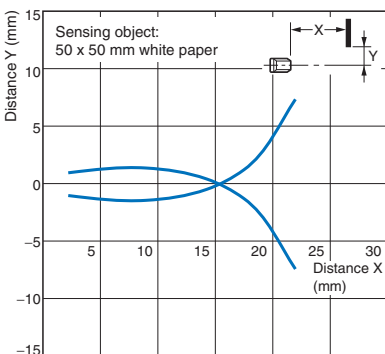

##### E3T-SL2□(M)

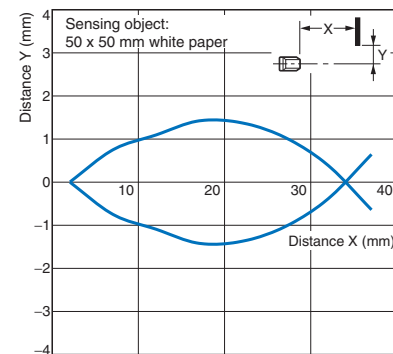

**BGS-reflective**  
**E3T-FL1□**

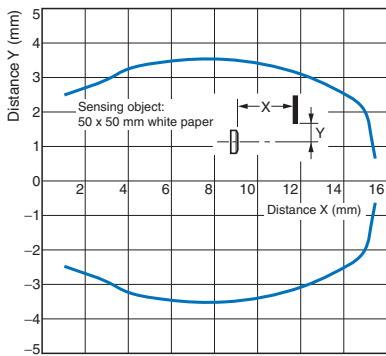

**E3T-FL2□**

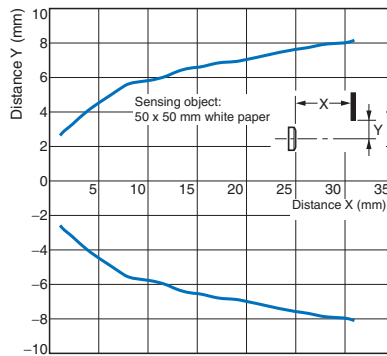

**Inclination Detection Area Characteristic**  
**Convergent-reflective**  
**E3T-SL1□(M) (Top to Bottom)**

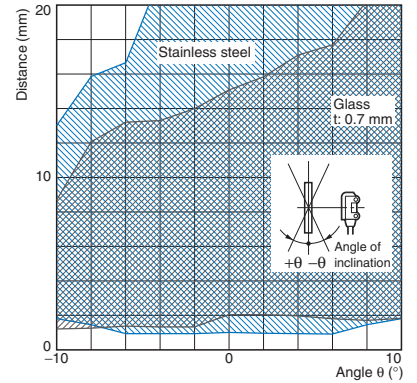

**E3T-SL1□(M) (Right to Left)**

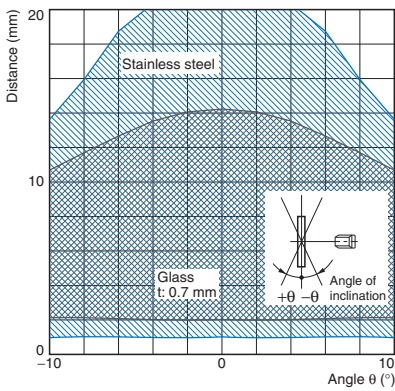

**E3T-SL2□(M) (Top to Bottom)**

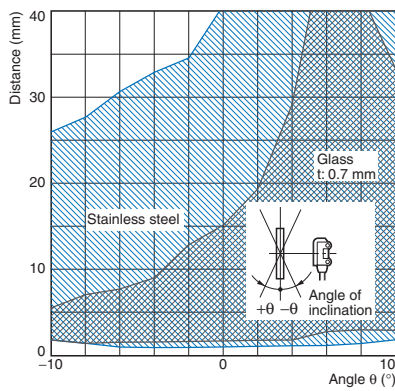

**E3T-SL2□(M) (Right to Left)**

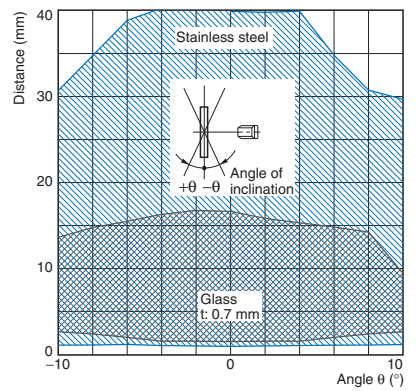

**BGS-reflective**

**E3T-FL1□ (Top to Bottom)**

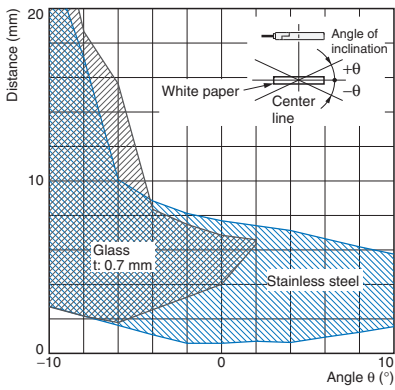

**E3T-FL1□ (Right to Left)**

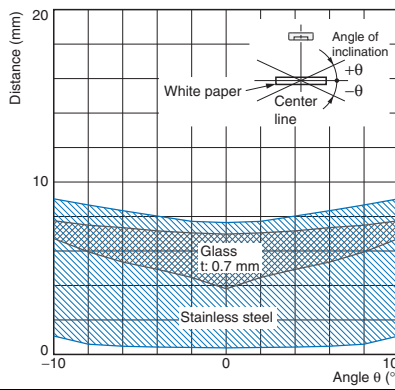

**E3T-FL2□ (Top to Bottom)**

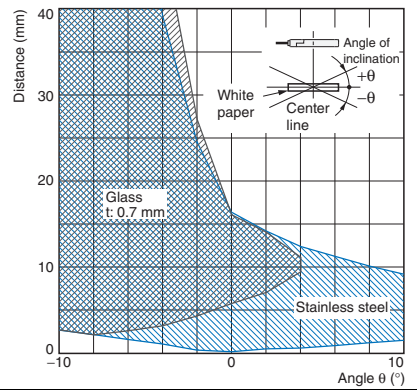

**E3T-FL2□ (Right to Left)**

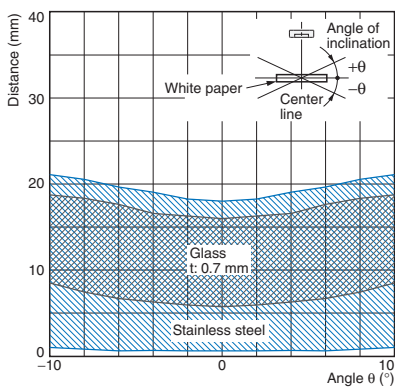

**Excess Gain vs. Set Distance**

**Through-beam**

**E3T-ST1□(M)/E3T-ST3□**

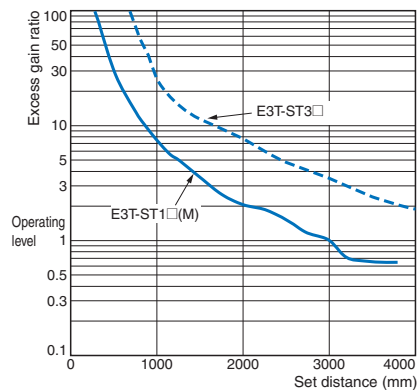

**E3T-ST2□(M)**

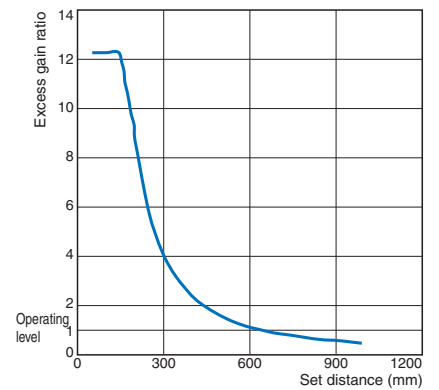

**E3T-FT1**

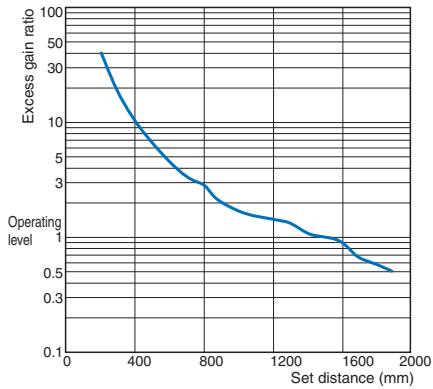

**E3T-FT2**

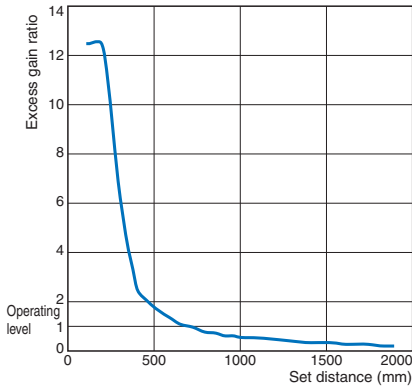

**Retro-reflective  
E3T-SR4**

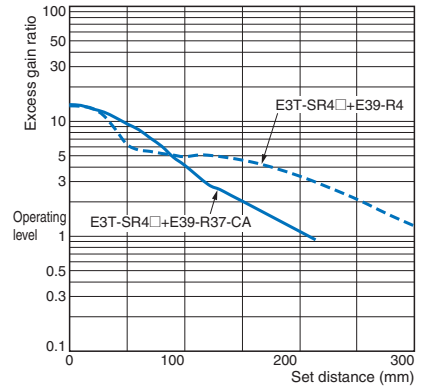

**Diffuse-reflective  
E3T-FD1(M)**

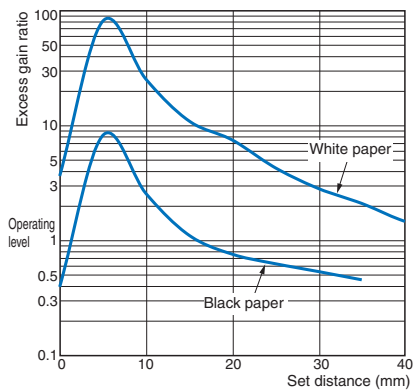

**Convergent-reflective  
E3T-SL1(M)**

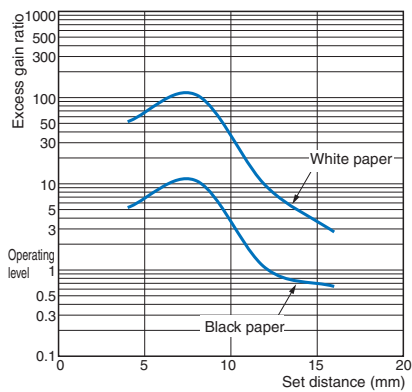

**E3T-SL2(M)**

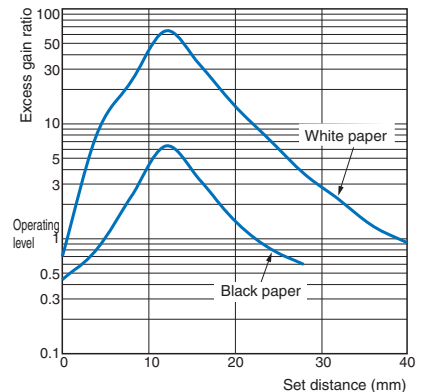

**Sensing Object Size vs. Sensing Distance**

**Convergent-reflective  
E3T-SL1(M)**

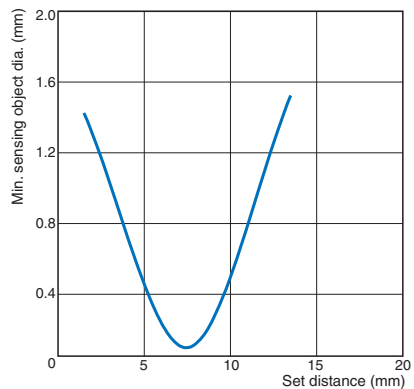

**Diffuse/Convergent-reflective  
E3T-FD1(M)/E3T-SL2(M)**

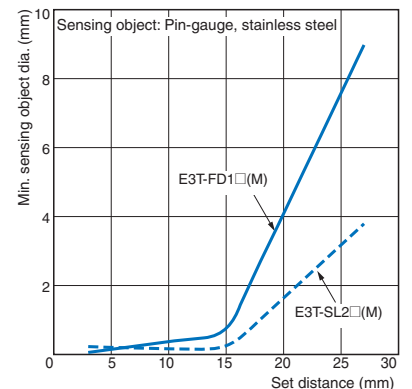

**Sensing Distance vs. Material**

**Convergent-reflective  
E3T-SL1(M)**

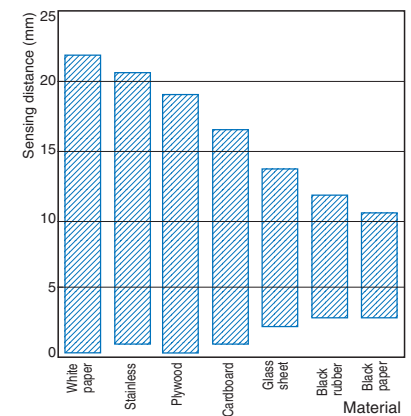

**E3T-SL2(M)**

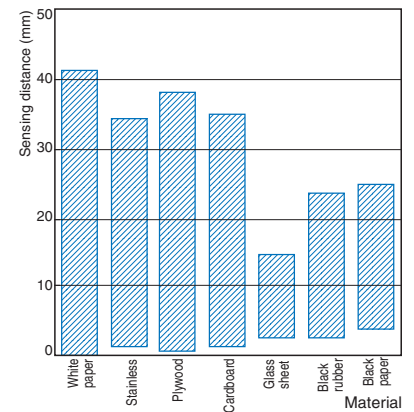

**Diffuse-reflective  
E3T-FD1(M)**

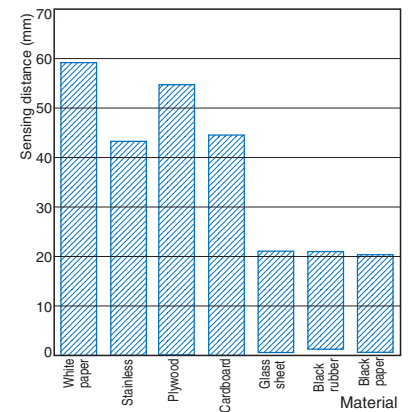

**BGS-reflective  
E3T-FL1**

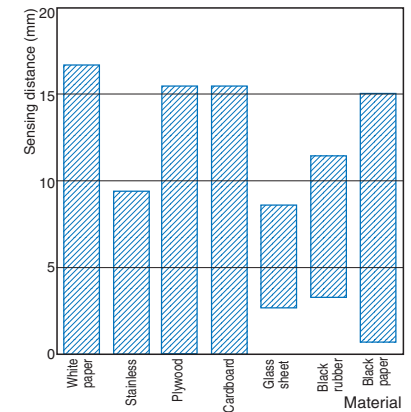

Sensing Distance Characteristics of Sensitivity Adjustment Unit  
(when Completing Optical Axis Adjustment)

E3T-ST1□ + E39-E10 Sensitivity Adjustment Unit  
E3T-ST3□ + E39-E10 Sensitivity Adjustment Unit

E3T-FL2□

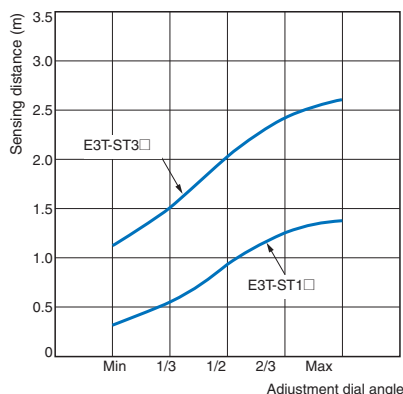
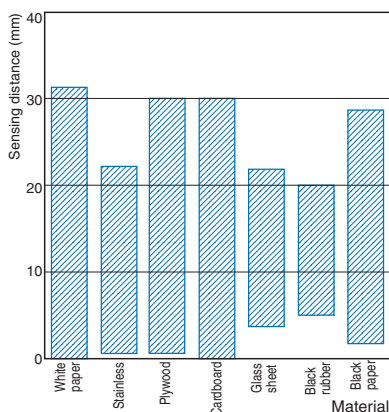

I/O Circuit Diagrams

NPN Output

Model	Operation mode	Timing charts	Output circuit
E3T-_1 E3T-_1M	Light-ON	<p>Light incident: [High pulse]</p> <p>Light interrupted: [Low pulse]</p> <p>Operation indicator (orange): ON [High pulse], OFF [Low pulse]</p> <p>Output transistor: ON [High pulse], OFF [Low pulse]</p> <p>Load (e.g., relay): Operate [High pulse], Reset [Low pulse]</p> <p>(Between brown and black)</p>	<p>Through-beam Receivers, Retroreflective and Reflective Models</p>
E3T-_2 E3T-_2M	Dark-ON	<p>Light incident: [High pulse]</p> <p>Light interrupted: [Low pulse]</p> <p>Operation indicator (orange): ON [Low pulse], OFF [High pulse]</p> <p>Output transistor: ON [Low pulse], OFF [High pulse]</p> <p>Load (e.g., relay): Operate [Low pulse], Reset [High pulse]</p> <p>(Between brown and black)</p>	<p>Through-beam Emitters</p>

PNP Output

Model	Operation mode	Timing charts	Output circuit
E3T-_3 E3T-_3M	Light-ON	<p>Light incident: [High pulse]</p> <p>Light interrupted: [Low pulse]</p> <p>Operation indicator (orange): ON [High pulse], OFF [Low pulse]</p> <p>Output transistor: ON [High pulse], OFF [Low pulse]</p> <p>Load (e.g., relay): Operate [High pulse], Reset [Low pulse]</p> <p>(Between blue and black leads)</p>	<p>Through-beam Receivers, Retroreflective and Reflective Models</p>
E3T-_4 E3T-_4M	Dark-ON	<p>Light incident: [High pulse]</p> <p>Light interrupted: [Low pulse]</p> <p>Operation indicator (orange): ON [Low pulse], OFF [High pulse]</p> <p>Output transistor: ON [Low pulse], OFF [High pulse]</p> <p>Load (e.g., relay): Operate [Low pulse], Reset [High pulse]</p> <p>(Between blue and black leads)</p>	<p>Through-beam Emitters</p>

## Safety Precautions

Refer to *Warranty and Limitations of Liability*.

### WARNING

This product is not designed or rated for ensuring safety of persons. Do not use it for such purpose.



Do not apply AC power to the E3T, otherwise the E3T may rupture.



### Precautions for Correct Use

Do not use the product in atmospheres or environments that exceed product ratings.

#### Wiring

The maximum power supply voltage is 26.4 VDC. Before turning the power ON, make sure that the power supply voltage be not more than maximum voltage.

#### Load short-circuit protection

The E3T incorporates a load short-circuit protection function. If the load short-circuits, the output of the E3T will be turned OFF. Then, recheck the wiring and turn on the E3T again to reset the load short-circuit protection function. The load short-circuit protection function will work if there is a current flow that is 1.5 times larger than the rated load current. When using a capacitance load, be sure that the inrush current will not exceed 1.5 times larger than the rated current.

#### Mounting

When mounting the Sensor, never strike it with a heavy object, such as a hammer. Doing so may reduce its watertight properties. Use screws with spring, flat, or toothed washers to secure the Sensor. Tightening Torque

M2-mounting Sensors: 0.15 N·m max  
M3-mounting Sensors: 0.5 N·m max

#### Mounting the Sensor on Moving Parts

Consider models that use break resistant cables (e.g., Robotics Cables) if the Sensor will be mounted on a moving part, such as a robot hand. The flexing resistance of Robotics Cable at approximately 400 thousand times is far superior to that of standard cable at approximately 14 thousand times.

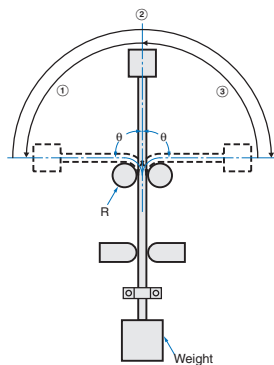

#### Cable Bending Rupture Test (Tough Cable Breaking Test)

The cable is repeatedly bent with power supplied to check the number of bends until the current is turned OFF.

Specimen		Standard cable 2.4-mm dia. (7/0.127-mm dia.), 3 conductors	Robotics cable 2.4-mm dia. (20/0.08-mm dia.), 3 conductors
Test	Bending angle (θ)	90° each to the left and right	
	Bending speed	50 times/min	
	Load	200 g	
	Operation per bend	Once in 1 to 3 in the diagram	
	Curvature radius of support point (R)	5 mm	
Result		Approx. 14,000 times	Approx. 400,000 times

### Adjusting Indicators

- The following graphs indicate the status of each operating level.
- Be sure to use the E3T within the stable operating range.

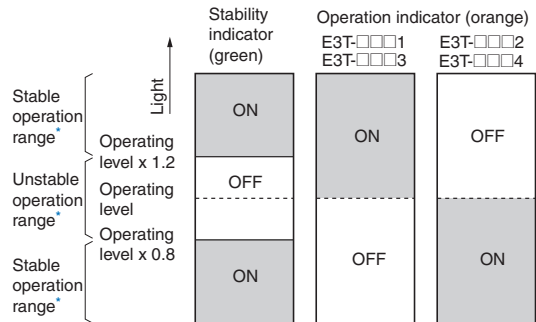

\* If the E3T fs operating level is set to the stable operation range, the E3T will be in most reliable operation without being influenced by temperature change, voltage fluctuation, dust, or setting change. If the operating level cannot be set to the stable operation range, pay attention to environmental changes while operating the E3T.

### Use of E39-E10 Sensitivity Adjustment Unit (Dark-ON: E3T-ST12)

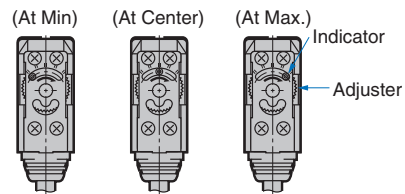

- Mount the Unit on the Receiver.
- Set the adjuster of the Sensitivity Adjustment Unit to Max. (Before shipping: Max.)
- After mounting on the Sensor, adjust the optical axis and secure the Sensor.
- Place a workpiece between the Emitter and Receiver and gradually turn the adjuster counterclockwise toward the Min. side. Stop turning the adjuster when the operation indicator and stability indicator (green) turn ON.
- Remove the workpiece and confirm that the operation indicator is OFF and the stability indicator (green) is ON. This completes the adjustment.

Note: If the light attenuation rate due to a workpiece is 40% or less, the stability indicator will not turn ON whether or not light is received. When the variation of light is small such as when sensing semi-transparent workpieces, carefully perform preliminary testing.

### Others

#### Do not install the E3T in the following locations.

- Locations subject to excessive dust or dirt
- Locations subject to direct sunlight
- Locations subject to corrosive gas
- Locations subject to contact with organic solvents
- Locations subject to vibration and shock
- Locations subject to contact with water, oil, or chemicals
- Locations subject to high humidities that might result in condensation

Dimensions

(Unit: mm)

Sensors

Tolerance class IT16 applies to dimensions in this datasheet unless otherwise specified.

M2-mounting Sensors

Through-beam Side-view Sensors

E3T-ST1□ (Emitter)

E3T-ST2□ (Emitter)

E3T-ST3□ (Emitter)



Emitter: E3T-ST□□-L  
Receiver: E3T-ST□□-D

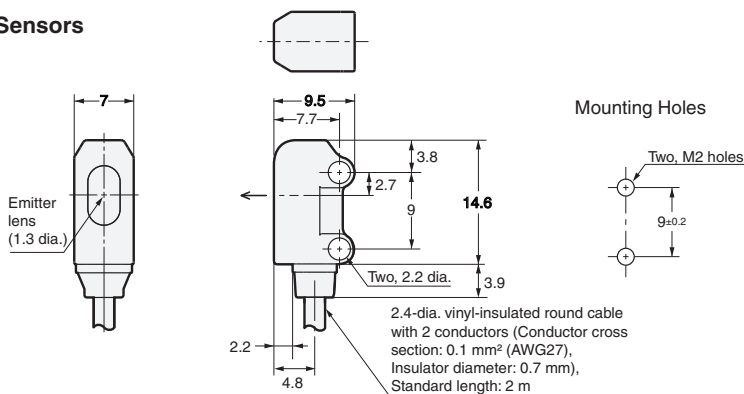

E3T-ST1□ (Receiver)

E3T-ST2□ (Receiver)

E3T-ST3□ (Receiver)

\*The receiver lens diameters are given below.

Model	Receiver lens diameter
E3T-ST1□-D E3T-ST2□-D	(1.3 dia.)
E3T-ST3□-D	(2.4 dia.)

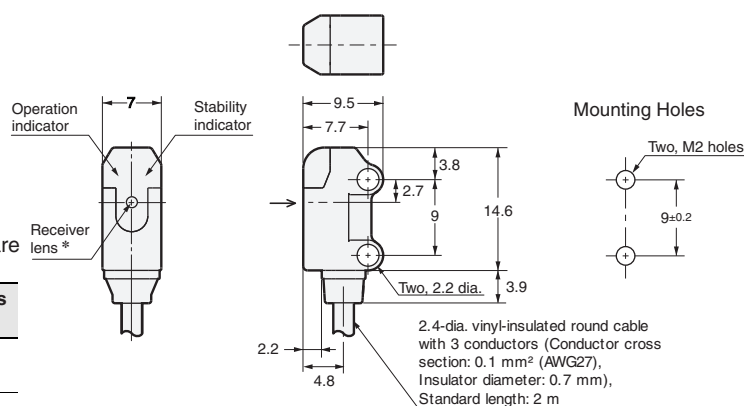

M12 Smartclick Pre-wired Connector Model (E3T-ST□□-M1TJ/E3T-FT□□-M1TJ)

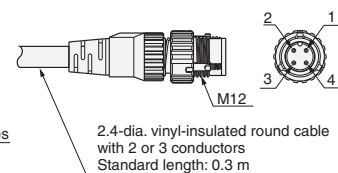

e-CON Pre-wired Connector Model (E3T-ST□□-ECON/E3T-FT□□-ECON)

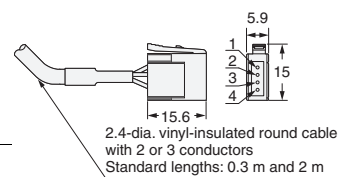

Through-beam Flat Sensors

E3T-FT1□ (Emitter)

E3T-FT2□ (Emitter)



Emitter: E3T-FT□□-L  
Receiver: E3T-FT□□-D

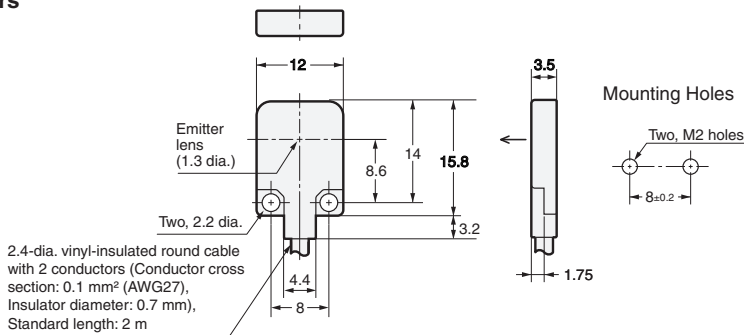

Terminal No.	Specifications
1	+V
2	---
3	0 V
4	Output (receiver only)

\* Refer to <Italic>Mounting the Sensor on Moving Parts on page 12 for details on Robotics Cable models.

E3T-FT1□ (Receiver)

E3T-FT2□ (Receiver)

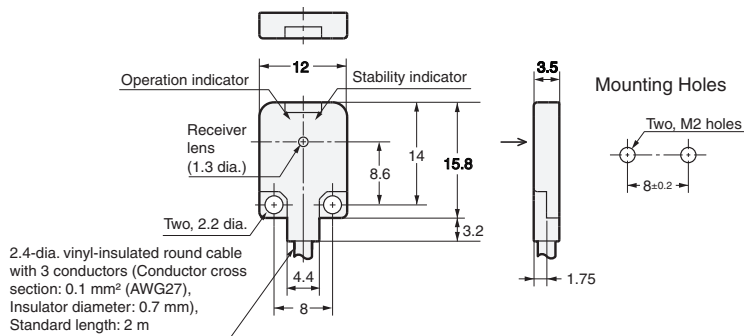

**Retro-reflective Side-view Sensors**

**E3T-SR4**

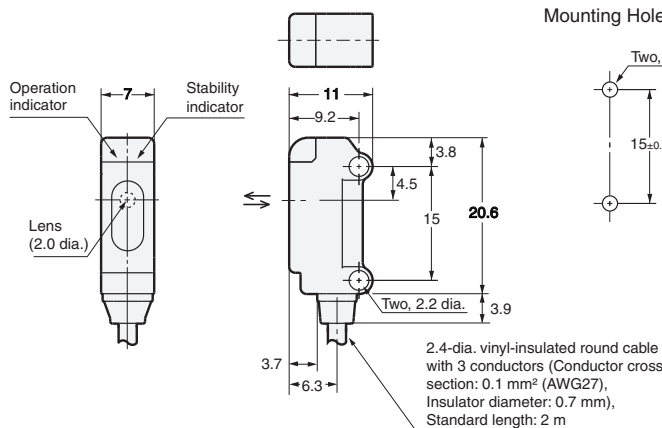

Mounting Holes

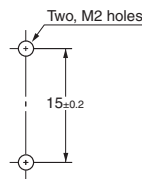

**M12 Smartclick Pre-wired Connector Model (E3T-SR□□-M1TJ/E3T-FD□□-M1TJ/E3T-SL□□-M1TJ)**

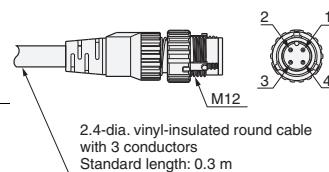

**Diffuse-reflective Flat Sensors**

**E3T-FD1**

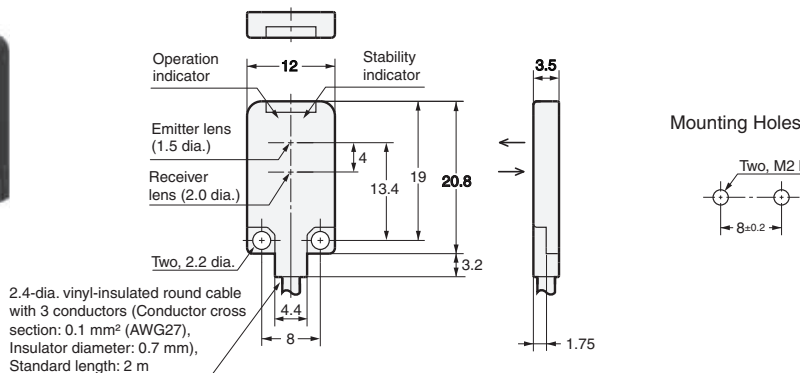
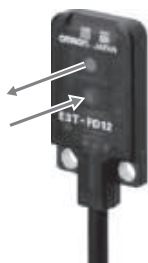

Mounting Holes

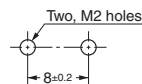

**e-CON Pre-wired Connector (E3T-SR□□-ECON/E3T-FD□□-ECON/E3T-SL□□-ECON)**

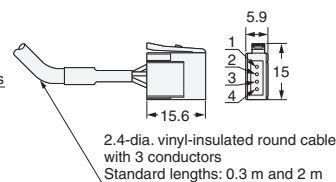

Terminal No.	Specifications
1	+V
2	---
3	0 V
4	Output

**Convergent-reflective Side-view Sensors**

**E3T-SL1**

**E3T-SL2**

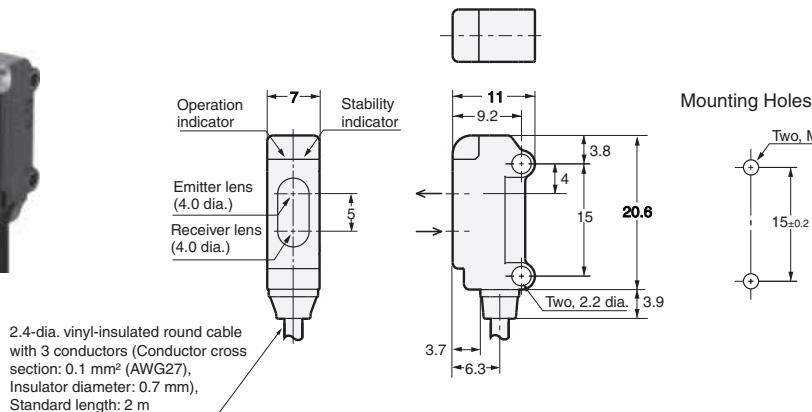
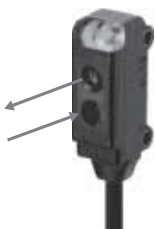

Mounting Holes

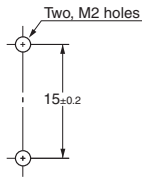

\* Refer to *Mounting the Sensor on Moving Parts* on page 12 for details on Robotics Cable models.

**BGS-reflective Flat Sensors**

E3T-FL1□

E3T-FL2□

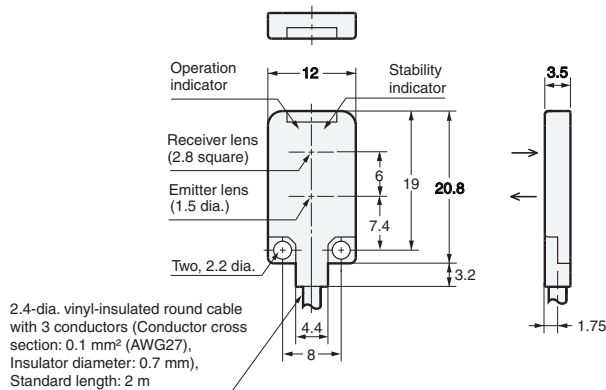
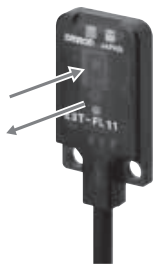

**M12 Smartclick Pre-wired Connector Model (E3T-FL□□-M1TJ)**

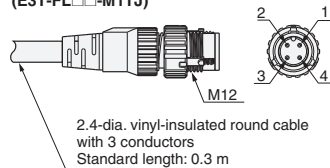

**e-CON Pre-wired Connector (E3T-FL□□-ECON)**

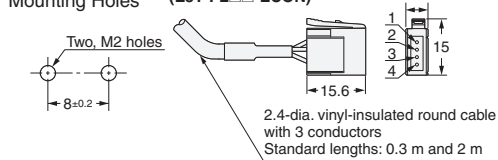

Terminal No.	Specifications
1	+V
2	---
3	0 V
4	Output

\* Refer to <Italic>Mounting the Sensor on Moving Parts on page 12 for details on Robotics Cable

**M3-mounting Sensors**

**Through-beam Side-view Sensors**

E3T-ST1□M (Emitter)

E3T-ST2□M (Emitter)

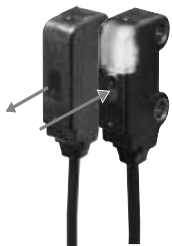

Emitter: E3T-ST□□M-L  
Receiver: E3T-ST□□M-D

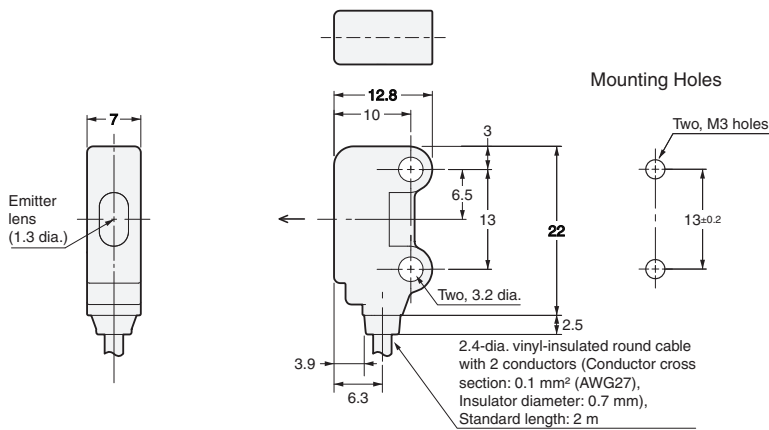

E3T-ST1□M (Receiver)

E3T-ST2□M (Receiver)

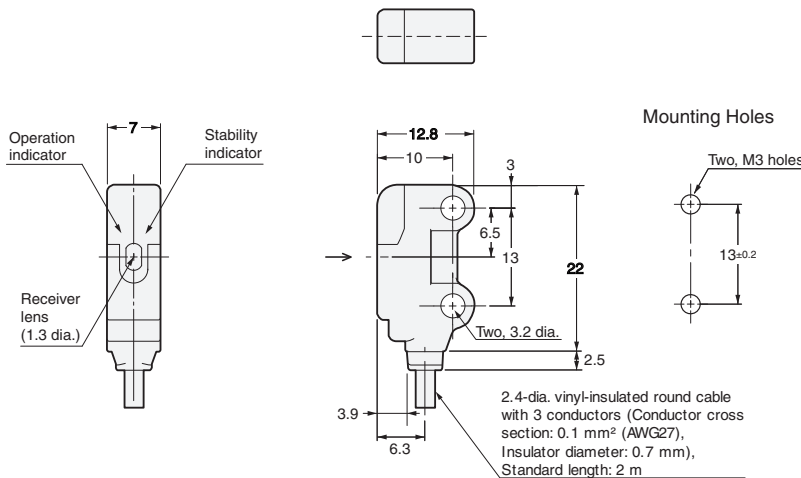

**Diffuse-reflective Flat Sensors**  
**E3T-FD1□M**

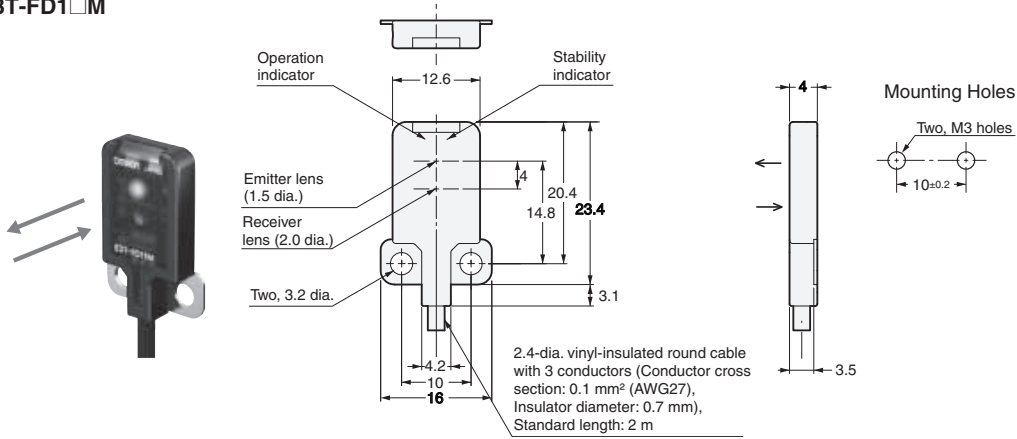

**Convergent-reflective Side-view Sensors**  
**E3T-SL1□M**  
**E3T-SL2□M**

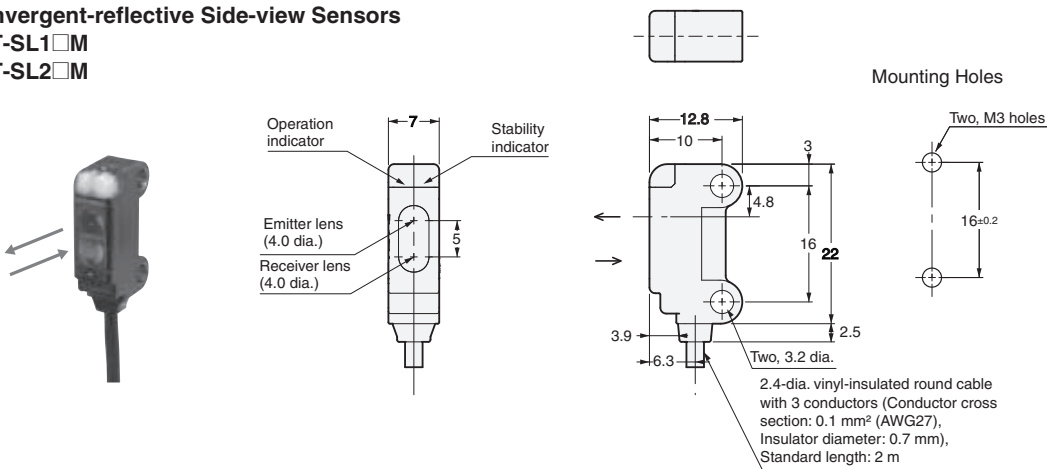

Accessories (Order Separately)

Tape Reflectors

E39-RS1-CA

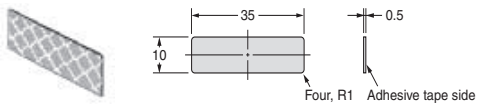

Material: Acrylic

E39-RS2-CA

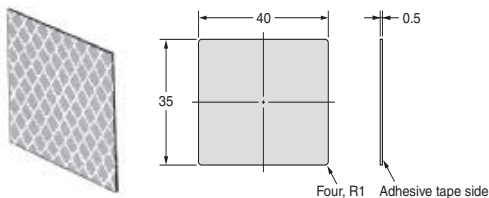

Material: Acrylic

E39-RS3-CA

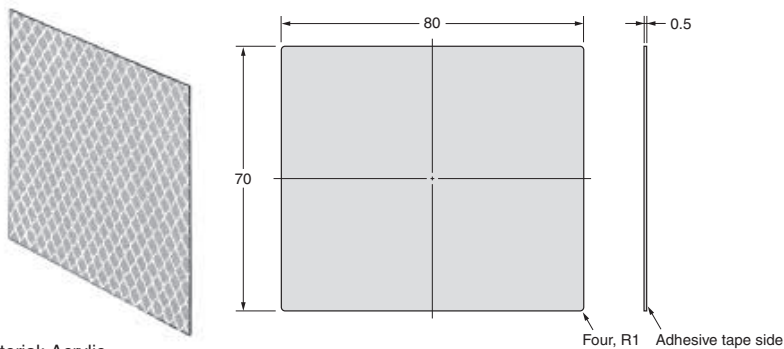

Material: Acrylic

Mutual Interference Prevention Filter for E3T-ST3□/ST1□ Through-beam Sensors

E39-E14

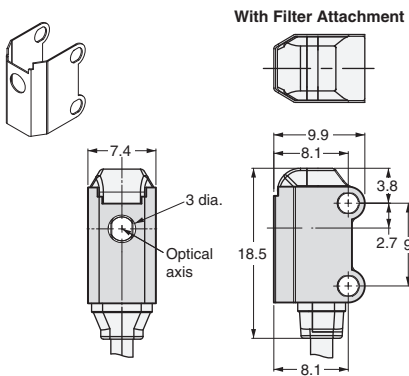

Material: 0.2-mm thick stainless steel (SUS301)

Slit for E3T-ST□□ Through-beam Sensors

E39-S63

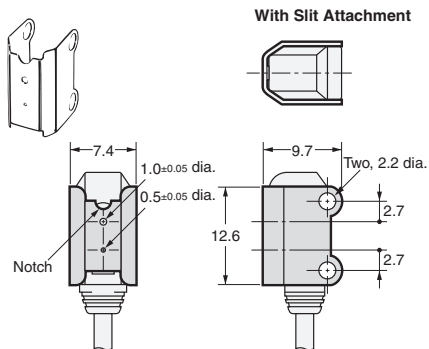

Material: 0.2-mm thick stainless steel (SUS301)

Note: Align the notch direction of the Slit when installing on the Emitter and Receiver.

Slit for E3T-FT□□ Through-beam Sensors

E39-S64

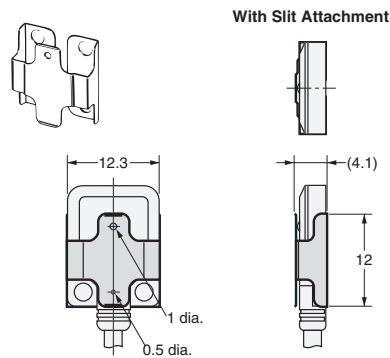

Material: 0.1-mm thick stainless steel (SUS301)

0.5-dia Slit for E3T-ST□□M Through-beam Sensors

E39-S76A

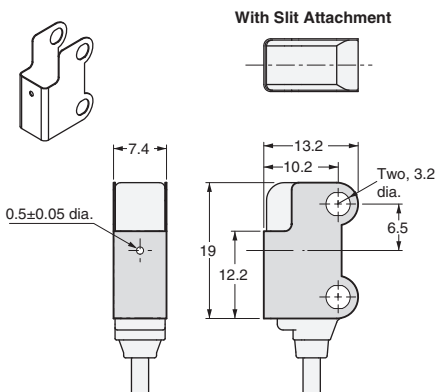

Material: 0.2-mm thick stainless steel (SUS301)

1-dia Slit for E3T-ST□□M Through-beam Sensors

E39-S76B

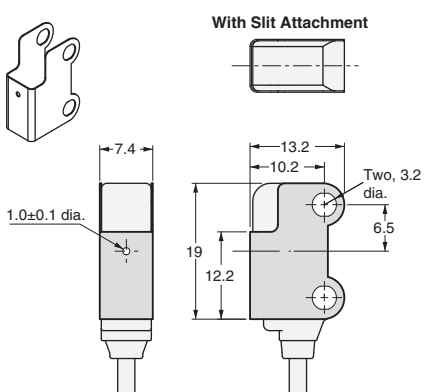

Material: 0.2-mm thick stainless steel (SUS301)

Sensitivity Adjustment Unit for E3T-ST1□/ST3□ Through-beam Sensors

E39-E10

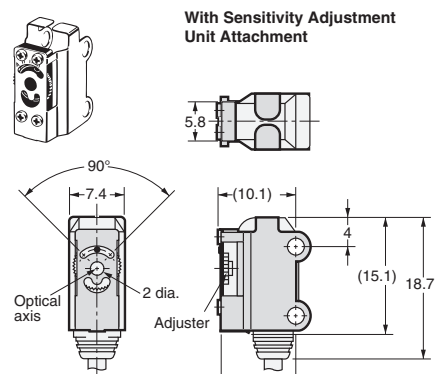

Material: stainless steel (SUS301)

**Mounting Bracket for M2-mounting Side-view Sensors**  
**E39-L116**



Material: 1.2-mm-thick stainless steel (SUS304)

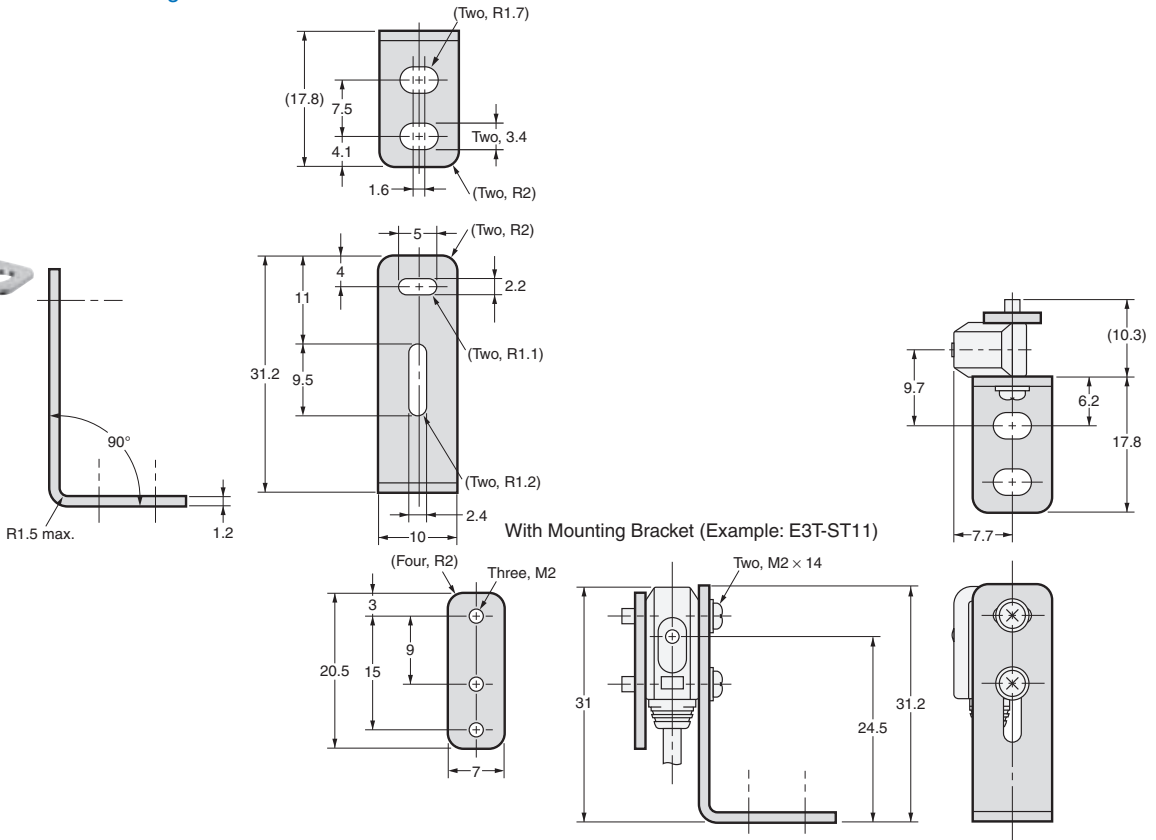

**Mounting Bracket for M2-mounting Side-view Sensors**  
**E39-L117**



Material: 1.2-mm-thick stainless steel (SUS304)

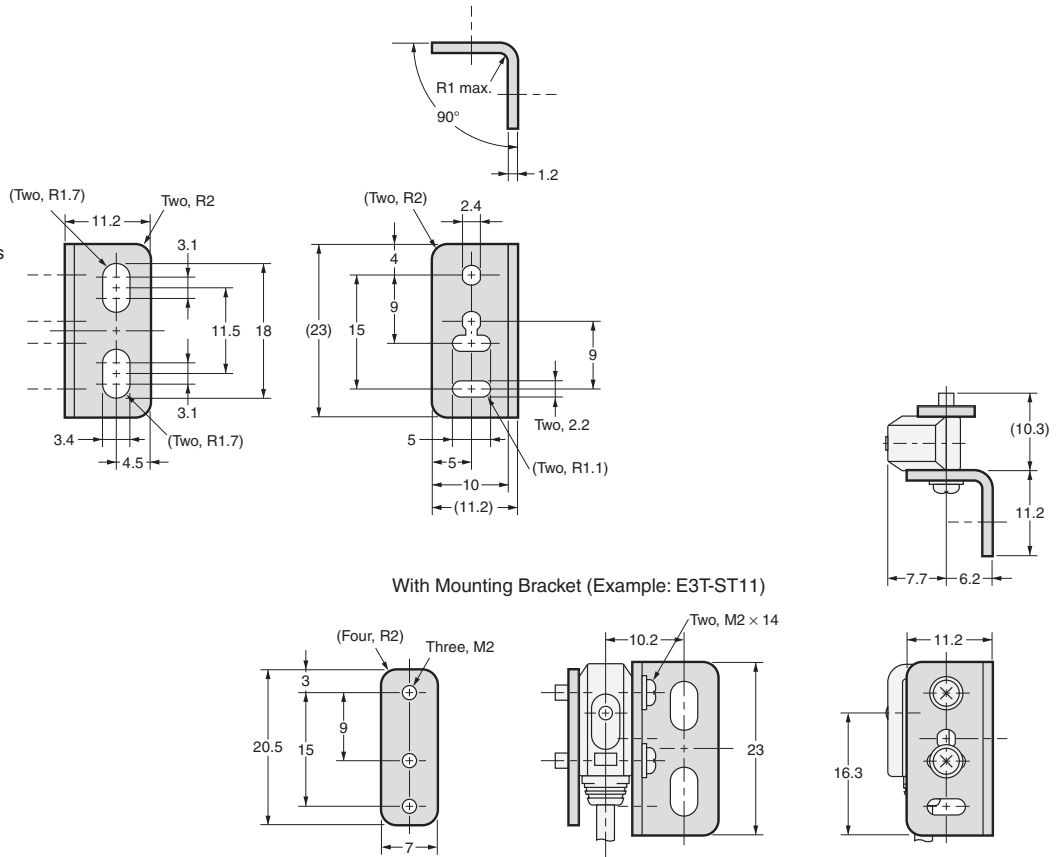

Mounting Bracket for M2-mounting Side-view Sensors

E39-L118



Material: 1.2-mm-thick stainless steel (SUS304)

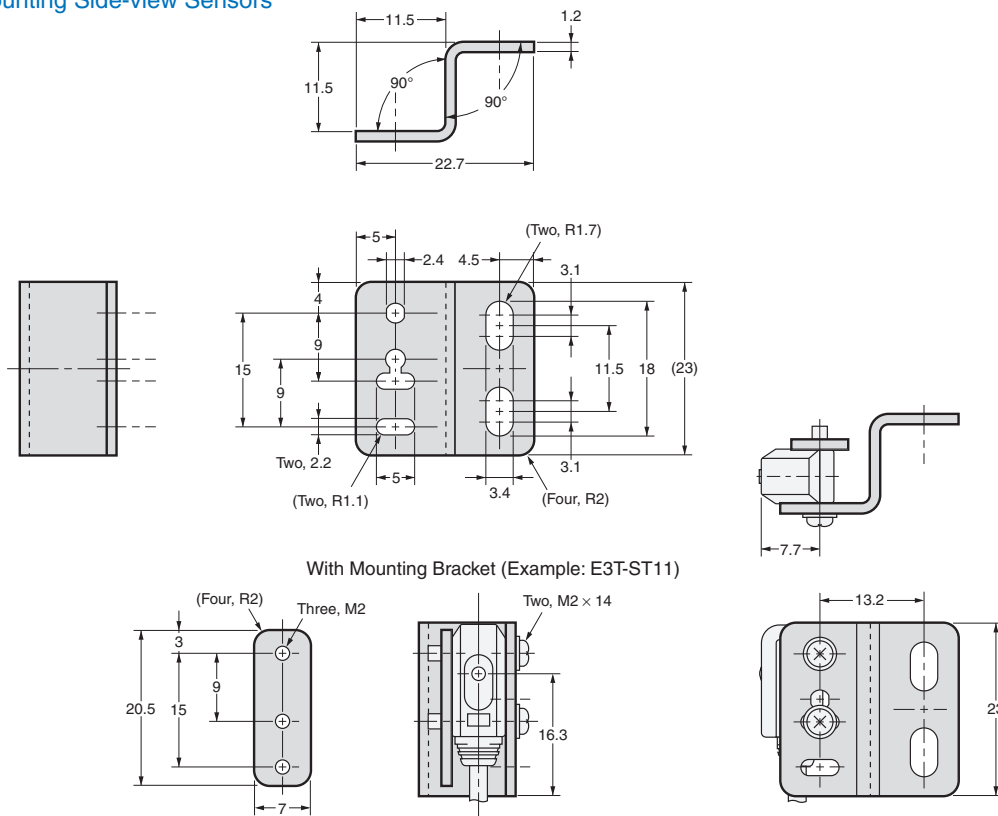

Mounting Bracket for M2-mounting Flat Sensors

E39-L119



Material: 1.2-mm-thick stainless steel (SUS304)

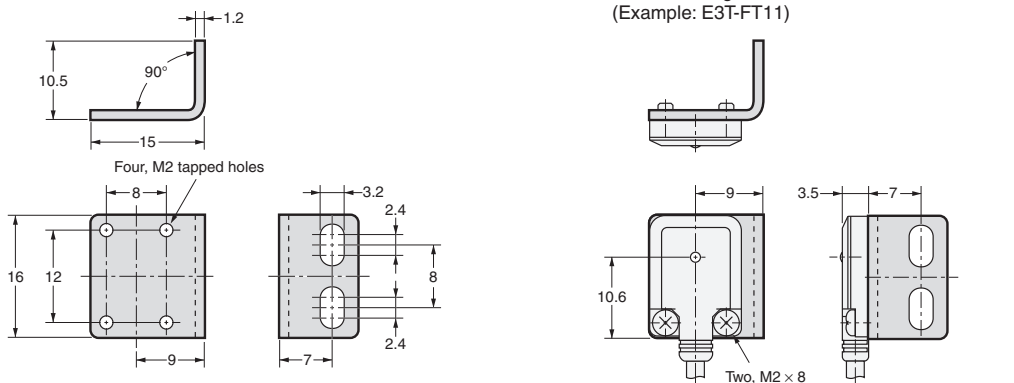

Mounting Bracket for M2-mounting Flat Sensors

E39-L120



Material: 1.2-mm-thick stainless steel (SUS304)

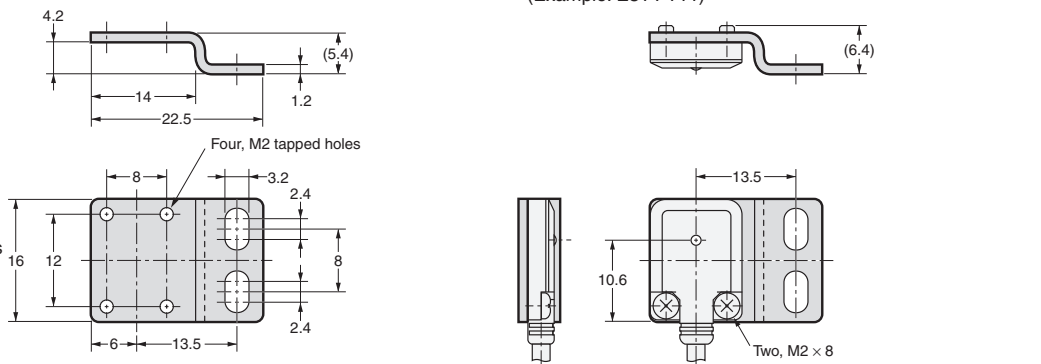

**Mounting Bracket for M3-mounting Side-view Sensors**  
**E39-L166**



Material: 1.2-mm-thick stainless steel (SUS304)

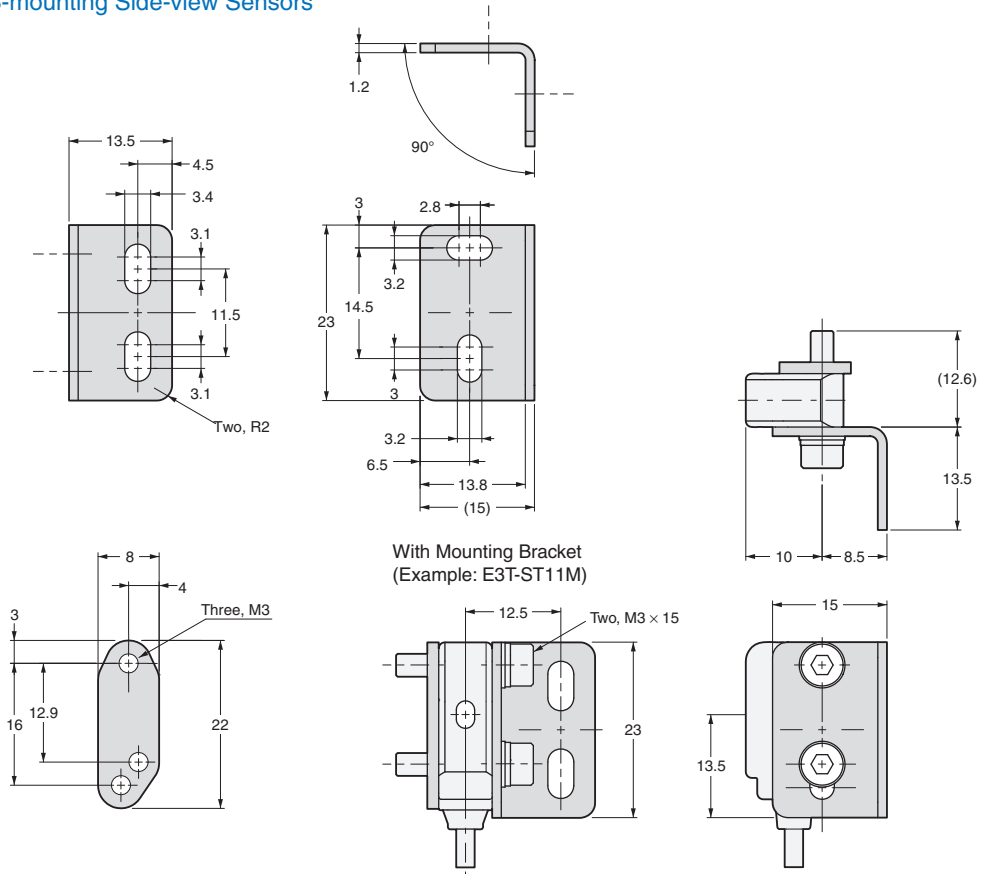

**Mounting Bracket for M3-mounting Flat Sensors**  
**E39-L167**



Material: 1.5-mm-thick stainless steel (SUS304)

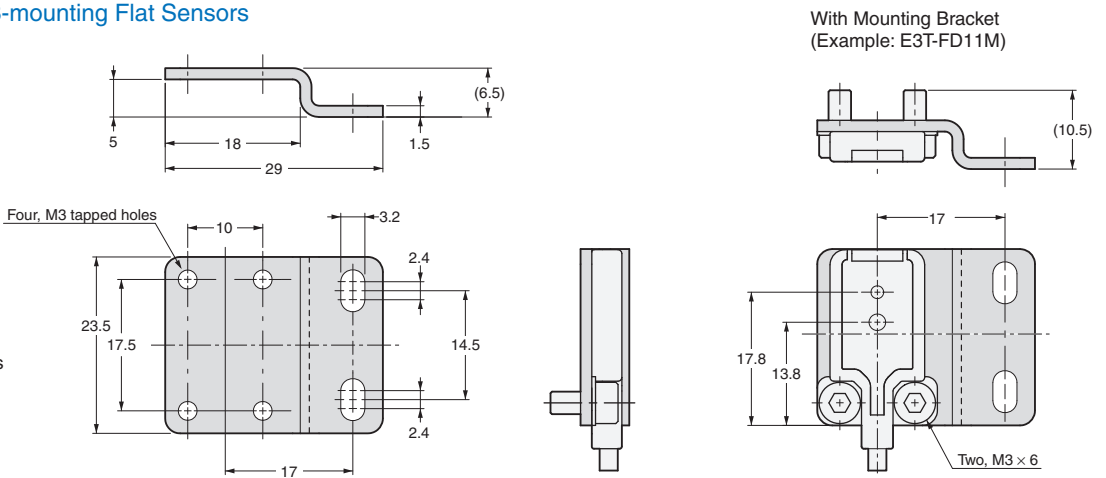

**Back-mounting Spacer for M3-mounting Flat Sensors**  
**E39-L168**

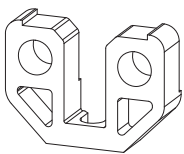

Material: PBT (polybutylene terephthalate)

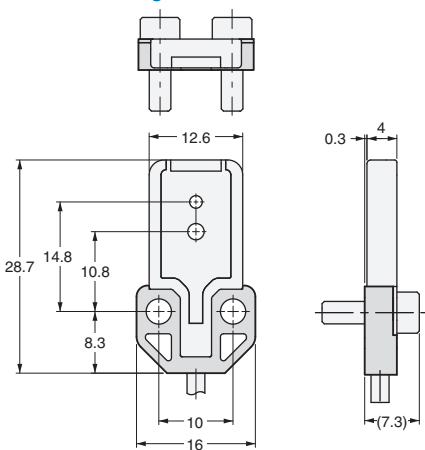

Note: Use this Spacer when mounting the Sensor from the back.

**READ AND UNDERSTAND THIS DOCUMENT**

Please read and understand this document before using the products. Please consult your OMRON representative if you have any questions or comments.

**WARRANTY**

OMRON's exclusive warranty is that the products are free from defects in materials and workmanship for a period of one year (or other period if specified) from date of sale by OMRON.

OMRON MAKES NO WARRANTY OR REPRESENTATION, EXPRESS OR IMPLIED, REGARDING NON-INFRINGEMENT, MERCHANTABILITY, OR FITNESS FOR PARTICULAR PURPOSE OF THE PRODUCTS. ANY BUYER OR USER ACKNOWLEDGES THAT THE BUYER OR USER ALONE HAS DETERMINED THAT THE PRODUCTS WILL SUITABLY MEET THE REQUIREMENTS OF THEIR INTENDED USE. OMRON DISCLAIMS ALL OTHER WARRANTIES, EXPRESS OR IMPLIED.

**LIMITATIONS OF LIABILITY**

OMRON SHALL NOT BE RESPONSIBLE FOR SPECIAL, INDIRECT, OR CONSEQUENTIAL DAMAGES, LOSS OF PROFITS OR COMMERCIAL LOSS IN ANY WAY CONNECTED WITH THE PRODUCTS, WHETHER SUCH CLAIM IS BASED ON CONTRACT, WARRANTY, NEGLIGENCE, OR STRICT LIABILITY.

In no event shall responsibility of OMRON for any act exceed the individual price of the product on which liability is asserted.

IN NO EVENT SHALL OMRON BE RESPONSIBLE FOR WARRANTY, REPAIR, OR OTHER CLAIMS REGARDING THE PRODUCTS UNLESS OMRON'S ANALYSIS CONFIRMS THAT THE PRODUCTS WERE PROPERLY HANDLED, STORED, INSTALLED, AND MAINTAINED AND NOT SUBJECT TO CONTAMINATION, ABUSE, MISUSE, OR INAPPROPRIATE MODIFICATION OR REPAIR.

**SUITABILITY FOR USE**

THE PRODUCTS CONTAINED IN THIS DOCUMENT ARE NOT SAFETY RATED. THEY ARE NOT DESIGNED OR RATED FOR ENSURING SAFETY OF PERSONS, AND SHOULD NOT BE RELIED UPON AS A SAFETY COMPONENT OR PROTECTIVE DEVICE FOR SUCH PURPOSES. Please refer to separate catalogs for OMRON's safety rated products.

OMRON shall not be responsible for conformity with any standards, codes, or regulations that apply to the combination of products in the customer's application or use of the product.

At the customer's request, OMRON will provide applicable third party certification documents identifying ratings and limitations of use that apply to the products. This information by itself is not sufficient for a complete determination of the suitability of the products in combination with the end product, machine, system, or other application or use.

The following are some examples of applications for which particular attention must be given. This is not intended to be an exhaustive list of all possible uses of the products, nor is it intended to imply that the uses listed may be suitable for the products:

- Outdoor use, uses involving potential chemical contamination or electrical interference, or conditions or uses not described in this document.
- Nuclear energy control systems, combustion systems, railroad systems, aviation systems, medical equipment, amusement machines, vehicles, safety equipment, and installations subject to separate industry or government regulations.
- Systems, machines, and equipment that could present a risk to life or property.

Please know and observe all prohibitions of use applicable to the products.

NEVER USE THE PRODUCTS FOR AN APPLICATION INVOLVING SERIOUS RISK TO LIFE OR PROPERTY WITHOUT ENSURING THAT THE SYSTEM AS A WHOLE HAS BEEN DESIGNED TO ADDRESS THE RISKS, AND THAT THE OMRON PRODUCT IS PROPERLY RATED AND INSTALLED FOR THE INTENDED USE WITHIN THE OVERALL EQUIPMENT OR SYSTEM.

**PERFORMANCE DATA**

Performance data given in this document is provided as a guide for the user in determining suitability and does not constitute a warranty. It may represent the result of OMRON's test conditions, and the users must correlate it to actual application requirements. Actual performance is subject to the OMRON Warranty and Limitations of Liability.

**CHANGE IN SPECIFICATIONS**

Product specifications and accessories may be changed at any time based on improvements and other reasons.

It is our practice to change model numbers when published ratings or features are changed, or when significant construction changes are made. However, some specifications of the product may be changed without any notice. When in doubt, special model numbers may be assigned to fix or establish key specifications for your application on your request. Please consult with your OMRON representative at any time to confirm actual specifications of purchased products.

**DIMENSIONS AND WEIGHTS**

Dimensions and weights are nominal and are not to be used for manufacturing purposes, even when tolerances are shown.

**ERRORS AND OMISSIONS**

The information in this document has been carefully checked and is believed to be accurate; however, no responsibility is assumed for clerical, typographical, or proofreading errors, or omissions.

**PROGRAMMABLE PRODUCTS**

OMRON shall not be responsible for the user's programming of a programmable product, or any consequence thereof.

**COPYRIGHT AND COPY PERMISSION**

This document shall not be copied for sales or promotions without permission.

This document is protected by copyright and is intended solely for use in conjunction with the product. Please notify us before copying or reproducing this document in any manner, for any other purpose. If copying or transmitting this document to another, please copy or transmit it in its entirety.

Cat. No. E71E-EN-01

**In the interest of product improvement, specifications are subject to change without notice.**

---

**OMRON EUROPE B.V.**

Wegalaan 67-69,  
NL-2132 JD, Hoofddorp,  
The Netherlands  
Phone: +31 23 568 13 00  
Fax: +31 23 568 13 88  
[www.industrial.omron.eu](http://www.industrial.omron.eu)



# SCATTERGOOD & JOHNSON LTD

ELECTRICAL ENGINEERING & FLUID CONTROL DISTRIBUTORS

Est.1899

At Scattergood & Johnson Ltd, we pride ourselves on being a technical distributor to specialist industries.

Working with a range of quality product suppliers across a number of specialist markets, we are not your average 'box shifter' - we are your technical and supply chain partner.

We fully support every product we sell - for free! Our internal team and external sales engineers can answer any product or application question, no matter the complexity.

Backing up this technical ability is a range of 50,000+ products available from stock for nationwide next day delivery (same day if required!), or you can collect what you need from any of our trade counters around the UK.

Select your specialist interest below to learn more about how we can help.

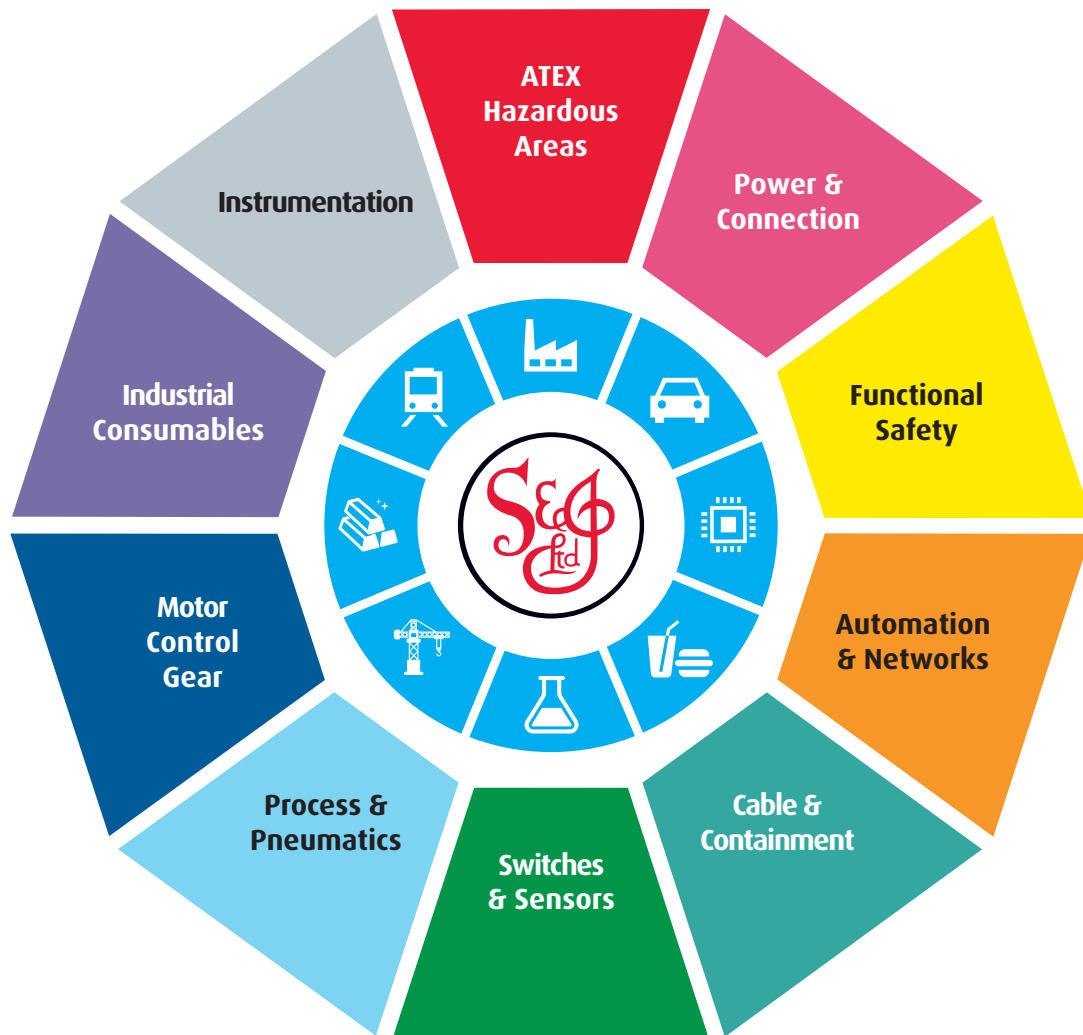

Online, In Branch and On the Road - Scattergood & Johnson Ltd, there when you need us.

# [www.scatts.co.uk](http://www.scatts.co.uk)