

OMRON**CompoBus/D-type Digital Controller****E5EK-DRT****Digital Controller for the CompoBus/D
and Conforming to the DeviceNet**

- Conforms to the DeviceNet and connects to a Programmable Controller without any programming.
- High performance range of 0.1% FS (Pt input: -100.0°C to 100.0°C).
- Simple initial settings when used with the Configurator (order separately).



CE RC

Ordering Information

Size	Communications	Model
48 x 96 mm	CompoBus/D	E5EK-AA2-DRT

- Note:**
1. The heater burnout alarm function can be used only when an ON/OFF Output Unit is used for the control outputs (heat).
 2. Be sure to specify the Current Transformer and Output Unit when ordering.

Description	Model	Specification
Output Unit (order separately)	E53-R	Relay
	E53-S	SSR
	E53-Q	Pulse (NPN) 12 VDC
	E53-Q3	Pulse (NPN) 24 VDC
	E53-Q4	Pulse (PNP) 24 VDC
	E53-C3	Linear (4 to 20 mA)
	E53-C3D	Linear (0 to 20 mA)
	E53-V34	Linear (0 to 10 V)
E53-V35	Linear (0 to 5 V)	

Note: The Digital Controller uses a dedicated, high-resolution Output Unit. The E53-C Current Output Unit for the E5□X cannot be used with the Digital Controller.

Inspection Report

The Digital Controller can be provided together with an Inspection Report.

Refer to the following legend with the suffix "K" when ordering a model provided together with an Inspection Report.
E5EK-AA2-DRT-K

■ Accessories (Order Separately)

Name	Model	Hole diameter
Current Transformer	E54-CT1	5.8 mm
	E54-CT3	12.0 mm

Note: No CT is required unless the heater burnout alarm function is used.

Name	Model	Connectable models
Terminal Cover	E53-COV08	E5EK

Name	Model	Description
One-branch T-branch Tap	DCN1-1C	With three connectors
Two-branch T-branch Tap	DCN1-3C	With five connectors
Communications Cable	Thin	DCA1-5C10 Outer diameter: 7.0 mm Length: 100 m
	Thick	DCA2-5C10 Outer diameter: 11.6 mm Length: 100 m
Terminal Block Terminating Resistor	DRS1-T	Resistance: 121 Ω

Note: Refer to *CompoBus/D Operation Manual (W267)* and *CompoBus/D Catalog (Q102)* for details such as ratings and characteristics.

■ Ranges

Platinum Resistance Thermometer

Input (switch selectable)		JPt100	Pt100	
Range	°C	-199.9 to 650.0	-199.9 to 650.0	-100.0 to 100.0
	°F	-199.9 to 999.9	-199.9 to 999.9	-150.0 to 250.0
Setting		0	1	22

Thermocouple

Input (switch selectable) (see note)		K		J		T	E	L		U	N	R	S	B	W	PLII
Range	°C	-200 to 1,300	0.0 to 500.0	-100 to 850	0.0 to 400.0	-199.9 to 400.0	0 to 600	-100 to 850	0.0 to 400.0	-199.9 to 400.0	-200 to 1,300	0 to 1,700	0 to 1,700	100 to 1,800	0 to 2,300	0 to 1,300
	°F	-300 to 2,300	0.0 to 900.0	-100 to 1,500	0.0 to 750.0	-199.9 to 700.0	0 to 1,100	-100 to 1,500	0.0 to 750.0	-199.9 to 700.0	-300 to 2,300	0 to 3,000	0 to 3,000	300 to 3,200	0 to 4,100	0 to 2,300
Setting		2	3	4	5	6	7	8	9	10	11	12	13	14	15	16

Note: Setting number is factory-set to 2 (K).

Thermocouple W is W/Re5-26 (tungsten rhenium 5, tungsten rhenium 26).

Current/Voltage

Input (switch selectable)	Current input		Voltage input		
	4 to 20 mA	0 to 20 mA	1 to 5 V	0 to 5 V	0 to 10 V
Range	One of following ranges depending on results of scaling -1999 to 9999 -199.9 to 999.9 -19.99 to 99.99 -1.999 to 9.999				
Setting	17	18	19	20	21

Specifications

■ Ratings

Supply voltage	100 to 240 VAC, 50/60 Hz, 24 VAC/DC
Operating voltage range	85% to 110% of rated supply voltage
Power consumption	15 VA (100 to 240 VAC), 12 VA (24 VAC), 8 W (24 VDC)
Input	Thermocouple: K, J, T, E, L, U, N, R, S, B, W, PLII Platinum resistance thermometer: JPt100, Pt100 Current input: 4 to 20 mA, 0 to 20 mA (Input impedance: 150 Ω) Voltage input: 1 to 5 V, 0 to 5 V, 0 to 10 V (Input impedance: 1 MΩ)
Input impedance	Current input: 150 Ω Voltage input: 1 MΩ min.
Auxiliary output	SPST-NO, 3 A at 250 VAC (resistive load)
Control method	ON/OFF or advanced PID control (with auto-tuning)
Setting method	Digital setting using front panel keys
Indication method	7-segment digital display and LEDs (Character height: PV: 14 mm, SV: 9.5 mm)
Control output	According to Output Unit (see <i>Output Unit Ratings and Characteristics</i>) (Attach an Output Unit that is sold separately.)
Remote SP input	Current input: 4 to 20 mA (Input impedance: 150 Ω)
Current Transformer input	Connect an exclusive Current Transformer (E54-CT1 or E54-CT3)
Other functions	<u>Standard</u> Manual output, heating/cooling control, SP limiter, loop burnout alarm, SP ramp, MV limiter, MV change rate limiter, input digital filter, input shift, run/stop, protect functions <u>Option</u> Run/Stop selection, etc.

- Note:**
1. To conform to EN50081-2 (FCC Class A) for ratings of noise terminal voltages, attach a noise filter (TDK ZCB2206-11 or equivalent) to the AC power supply line.
 2. Fuzzy self-tuning is not provided with the E5EK-DRT.

■ Characteristics

Indication accuracy	Thermocouple (see note 1): (±0.3% of indication value or ±1°C, whichever greater) ±1 digit max. Platinum resistance thermometer (see note 2): (±0.2% of indication value or ±0.8°C, whichever greater) ±1 digit max. Analog input: ±0.2% FS ±1 digit max.
Hysteresis	0.01% to 99.99% FS (in units of 0.01% FS)
Proportional band (P)	0.1% to 999.9% FS (in units of 0.1% FS)
Integral (reset) time (I)	0 to 3,999 s (in units of 1 s)
Derivative (rate) time (D)	0 to 3,999 s (in units of 1 s)
Control period	1 to 99 s (in units of 1 s)
Manual reset value	0.0% to 100.0% (in units of 0.1%)
Alarm setting range	-1,999 to 9,999 or -199.9 or 999.9 (decimal point position dependent on input type)
Sampling period (see note 3)	Temperature input: 250 ms Analog input: 100 ms
Insulation resistance	20 MΩ min. (at 500 VDC)
Dielectric strength	2,000 VAC, 50/60 Hz for 1 min between terminals of different polarities
Vibration resistance	Malfunction: 10 to 55 Hz, 10 m/s ² (approx. 1G) for 10 min each in X, Y, and Z directions Destruction: 10 to 55 Hz, 20 m/s ² (approx. 2G) for 2 hrs each in X, Y, and Z directions
Shock resistance	Malfunction: 200 m/s ² min. (approx. 20G), 3 times each in 6 directions (100 m/s ² (approx. 10G) applied to the relay) Destruction: 300 m/s ² min. (approx. 30G), 3 times each in 6 directions
Ambient temperature	Operating: -10°C to 55°C (with no icing)/3-year warranty period: -10°C to 50°C Storage: -25°C to 65°C (with no icing)
Ambient humidity	Operating: 35% to 85%
Enclosure ratings	Front panel: NEMA4 for indoor use (equivalent to IP66) Rear case: IEC standard IP20 Terminals: IEC standard IP00
Memory protection	Non-volatile memory (number of writings: 100,000 operations)
Weight	Approx. 320 g Mounting bracket: approx. 65 g
EMC	Emission Enclosure: EN55011 Group 1 class A Emission AC Mains: EN55011 Group 1 class A Immunity ESD: EN61000-4-2: 4 kV contact discharge (level 2) 8 kV air discharge (level 3) Immunity RF-interference: ENV50140: 10 V/m (amplitude modulated, 80 MHz to 1 GHz) (level 3) 10 V/m (pulse modulated, 900 MHz) Immunity Conducted Disturbance: ENV50141: 10 V (0.15 to 80 MHz) (level 3) Immunity Burst: EN61000-4-4: 2 kV power-line (level 3) 2 kV I/O signal-line (level 4)
Approved standards	UL1092, CSA22.2 No. 14, CSA22.2 No. 1010-1 Conforms to EN50081-2, EN50082-2, EN61010-1 (IEC61010-1) Conforms to VDE0106/part 100 (Finger Protection), when the separately-ordered terminal cover is mounted.

- Note:**
- The indication accuracy of the K, T, and N thermocouples at a temperature of -100°C or less is ±2°C ±1 digit maximum.
The indication accuracy of the B thermocouple at a temperature of 400°C or less is unrestricted.
The indication accuracy of the R and S thermocouples at a temperature of 200°C or less is ±3°C ±1 digit maximum.
The indication accuracy of the W thermocouple at any temperature is (±0.3% of the indicated value or ±3°C, whichever is greater) ±1 digit maximum.
The indication accuracy of the PLII thermocouple at any temperature is (±0.3% or ±2°C, whichever is greater) ±1 digit maximum.
 - The indication accuracy of the Pt at -100.0°C to 100.0°C is ±0.1% FS ±1 digit maximum.
 - The sampling period of the standard model with CT and remote SP inputs is 250 ms.

■ Communication Characteristics

Conforms to DeviceNet communications protocol.

For details, refer to the *CompoBus/D Operation Manual (W267)* and *E5EK CompoBus/D-type Digital Controller Operation Manual (H99)*.

Connection forms		Combination of multi-drop and T-branch connections (see note 1)
Communications baud rate		500 kbps, 250 kbps, or 125 kbps (set using the front panel keys)
Communications media		Special 5-wire cables (2 signal lines, 2 power lines, 1 shield line)
Communications distance	500 kbps	Network length (see note 2): 100 m max. (see note 3) Drop line length: 6 m max. Total drop line length: 39 m max.
	250 kbps	Network length (see note 2): 250 m max. (see note 3) Drop line length: 6 m max. Total drop line length: 78 m max.
	125 kbps	Network length (see note 2): 500 m max. (see note 3) Drop line length: 6 m max. Total drop line length: 156 m max.
Max. number of nodes		64 nodes (including Master)
Max. number of Slaves		63 Slaves
Error control checks		CRC error check, duplicate node address check

- Note:**
1. External Terminating Resistor is required.
 2. Indicates the maximum distance between nodes.
 3. The distance is less than 100 m when thin cables are used for the trunk lines.

■ Output Unit Ratings and Characteristics

Relay output	5 A at 250 VAC (resistive load)
SSR output	1 A at 75 to 250 VAC (resistive load)
Voltage output	NPN: 40 mA at 12 VDC (with short-circuit protection) NPN: 20 mA at 24 VDC (with short-circuit protection) PNP: 20 mA at 24 VDC (with short-circuit protection)
Linear current output	4 to 20 mA, permissible load impedance: 600 Ω max., resolution: approx. 2,600 0 to 20 mA, permissible load impedance: 600 Ω max., resolution: approx. 2,600
Linear voltage output	0 to 10 VDC, permissible load impedance: 1 kΩ max., resolution: approx. 2,600 0 to 5 VDC, permissible load impedance: 1 kΩ max., resolution: approx. 2,600

■ Current Transformer Ratings

Dielectric strength	1,000 VAC (for 1 min)
Vibration resistance	50 Hz, 98 m/s ² (10G)
Weight	E54-CT1: approx. 11.5 g; E54-CT3: approx. 50 g
Accessories (E54-CT3 only)	Armature: 2; Plug: 2

■ Heater Burnout Alarm

Max. heater current	Single-phase 50 A AC (see note 1)
Heater current value display accuracy	±5% FS±1 digit max.
Heater burnout alarm setting range	0.1 to 49.9 A (in units of 0.1 A) (see note 2)
Min. detection ON time	190 ms (see note 3)

- Note:**
1. Use the K2CU-F□□A-□GS (with gate input terminals) for the detection of three-phase heater burnout.
 2. The heater burnout alarm is always OFF if the alarm is set to 0.0 A and always ON if the alarm is set to 50.0 A.
 3. No heater burnout detection or heater current value measurement is possible if the control output (heat) is ON for less than 190 ms.

This product has been tested by ODVA's authorized Independent Test Lab and found to comply with ODVA Conformance Test Software Version 2.0-1.00.

Dimensions

Note: All units are in millimeters unless otherwise indicated.

E5EK-DRT

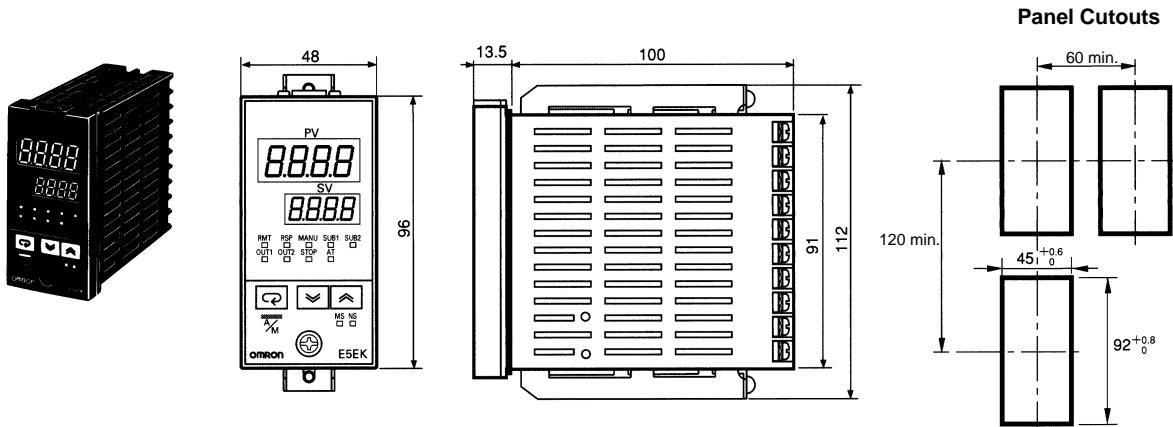

Note: Rear case width is 44 mm.

- Note:
1. Recommended panel thickness is 1 to 8 mm.
 2. Maintain the specified vertical and horizontal mounting space between each Unit. Units must not be closely mounted vertically or horizontally.

Installation

External Connection

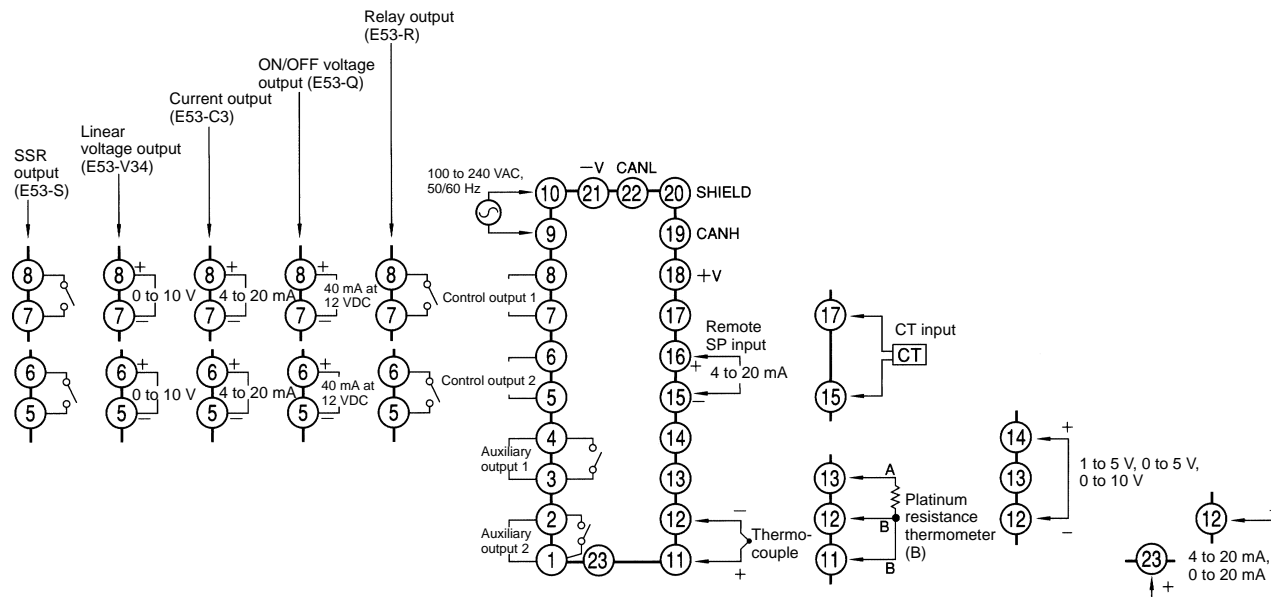

Precautions

For application precautions, refer to the *CompoBus/D Operation Manual (W267)* and *E5EK CompoBus/D-type Digital Controller Operation Manual (H99)*.

ALL DIMENSIONS SHOWN ARE IN MILLIMETERS.

To convert millimeters into inches, multiply by 0.03937. To convert grams into ounces, multiply by 0.03527.

Cat. No. H98-E1-1 **In the interest of product improvement, specifications are subject to change without notice.**

OMRON Corporation

Supervisory Control Devices Division

28th Fl., Crystal Tower Bldg.,

1-2-27, Shiromi, Chuo-ku,

Osaka 540-6028 Japan

Phone: (81)6-949-6035 Fax: (81)6-949-6069

Printed in Japan

0398-1M (0398) a



SCATTERGOOD & JOHNSON LTD

ELECTRICAL ENGINEERING & FLUID CONTROL DISTRIBUTORS

Est.1899

At Scattergood & Johnson Ltd, we pride ourselves on being a technical distributor to specialist industries.

Working with a range of quality product suppliers across a number of specialist markets, we are not your average 'box shifter' - we are your technical and supply chain partner.

We fully support every product we sell - for free! Our internal team and external sales engineers can answer any product or application question, no matter the complexity.

Backing up this technical ability is a range of 50,000+ products available from stock for nationwide next day delivery (same day if required!), or you can collect what you need from any of our trade counters around the UK.

Select your specialist interest below to learn more about how we can help.



Online, In Branch and On the Road - Scattergood & Johnson Ltd, there when you need us.

www.scatts.co.uk