

Temperature Controller

E5CB (48 × 48 mm)

Ideal for heater control, these Temperature Controllers offer the highest control performance at surprisingly low cost!

Easy to Read with One of the Largest Character Displays Anywhere.

- Improved visibility with character height of approx. 16 mm.
- Depth beyond front panel: Only 60 mm.
- Simple setup: less than 20 parameters,
- Faster sampling and loop-update at 250 ms.



48 × 48 mm

NEW

Main I/O Functions

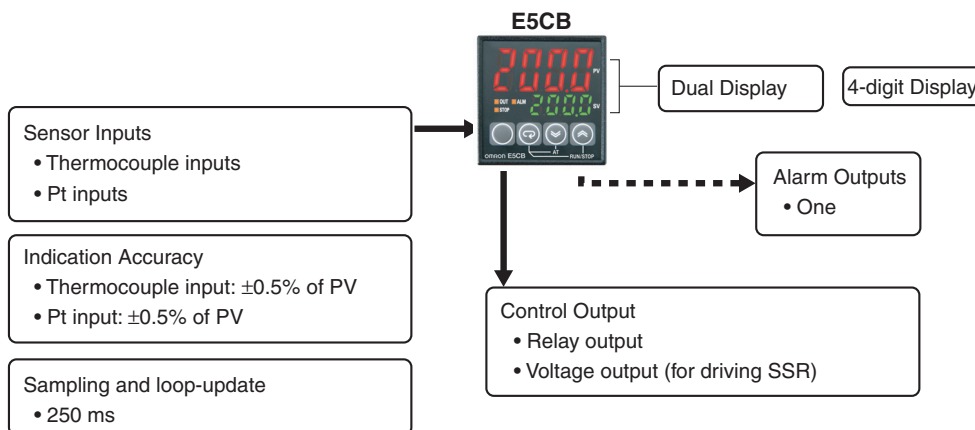

Model Number Structure

Model Number Legend

E5CB-□1□□
1 2 3 4

- Control Output**
 - R: Relay output: 250 VAC, 3 A
 - Q: Voltage output (for driving SSR): 12 VDC, 21 mA
- Alarm**
 - 1: Relay output: 250 VAC, 1 A (resistive load)
- Sensor type**
 - TC: Thermocouple (K, J, T, R, or S)
 - P: Platinum resistance thermometer (Pt100)
- Power Supply Voltage**
 - Blank: 100 to 240 VAC
 - D: 24 VAC/VDC

E5CB

Ordering Information

Temperature Controllers

Size	Power supply voltage	Input type	Alarm output	Control output	Model
E5CB 48 × 48 mm	100 to 240 VAC	Thermocouple	1	Relay output	E5CB-R1TC
		Platinum resistance thermometer			E5CB-R1P
		Thermocouple		Voltage output (for driving SSR)	E5CB-Q1TC
		Platinum resistance thermometer			E5CB-Q1P
	24 VAC/VDC	Thermocouple		Relay output	E5CB-R1TCD
		Platinum resistance thermometer			E5CB-R1PD
		Thermocouple		Voltage output (for driving SSR)	E5CB-Q1TCD
		Platinum resistance thermometer			E5CB-Q1PD

Accessories (Order Separately)

Terminal Cover

Model	E53-COV19
-------	-----------

Mounting Adapter (Included)

Model	Y92F-49
-------	---------

USB-Serial Conversion Cable

Model	E58-CIFQ2
-------	-----------

Waterproof Packing (Included)

Model	Y92S-P6
-------	---------

Specifications

Ratings

Power supply voltage	100 to 240 VAC 50/60 Hz, 24 VAC 50/60 Hz, or 24 VDC
Operating voltage range	85% to 110% of rated supply voltage
Power consumption	Approx. 3.5 VA (100 to 240 VAC) Approx. 3.5 VA (24 VAC) Approx. 2.5 W (24 VDC)
Sensor input	Models with thermocouple inputs Thermocouple: K, J, T, R, or S (JIS C 1602-1995, IEC60584-1) Models with platinum resistance thermometer inputs Platinum resistance thermometer: Pt100 (JIS C 1604-1997, IEC60751)
Control output	Relay output
	Voltage output (for driving SSR)
Alarm output	Relay output
Control method	SPST-NO, 250 VAC, 3 A (resistive load), electrical life: 100,000 operations, minimum applicable load: 5 V, 10 mA
Setting method	ON/OFF control or 2-PID control (with auto-tuning)
Indication method	Digital setting using front panel keys
Other functions	7-segment digital display and individual indicators Character height: 16.2 mm (PV)
Ambient operating temperature	Temperature input shift, run/stop, protection functions, etc.
Ambient operating humidity	–10 to 55°C (with no condensation or icing)/With a three-year guarantee: –10 to 50°C
Storage temperature	25% to 85%
	–25 to 65°C (with no condensation or icing)

Input Ranges

Models with Thermocouple Inputs

Model (temperature input)	Set value	Input type	Range	
			°C	°F
TC input	0	K	-200 to 1,300	-300 to 2,300
	1		-20.0 to 500.0	0.0 to 900.0
	2	J	-100 to 850	-100 to 1500
	3		-20.0 to 400.0	0.0 to 750.0
	4	T	-200 to 400	-300 to 700
	5		-199.9 to 400.0	-199.9 to 700.0
	6	R	0 to 1,700	0 to 3,000
7	S	0 to 1,700	0 to 3,000	

Default setting: 0

Applicable standards (K, J, T, R, S): JIS C1602-1995 and IEC 60584-1

Platinum Resistance Thermometer Input

Model (temperature input)	Set value	Input type	Range	
			°C	°F
Pt input	8	Pt100	-200 to 850	-300 to 1500
	9		-199.9 to 500.0	-199.9 to 900.0

Default setting: 8

Applicable standards (Pt100): JIS C1604-1997 and IEC 60751

Alarm Types

Select alarm types out of the 11 alarm types listed in the following table.

Setting	Alarm type	Positive alarm value (X)	Negative alarm value (X)	Deviation alarm/absolute value alarm
0	No alarm	Output OFF		
1	Upper/lower limit		Always ON	Deviation alarm
2	Upper limit			Deviation alarm
3	Lower limit			Deviation alarm
4	Upper/lower range		Always OFF	Deviation alarm
5 (See note 2.)	Upper/lower limit standby sequence ON		Always OFF	Deviation alarm
6 (See note 2.)	Upper limit standby sequence ON			Deviation alarm
7 (See note 2.)	Lower limit standby sequence ON			Deviation alarm
8	Absolute value upper limit			Absolute value alarm
9	Absolute value lower limit			Absolute value alarm
10 (See note 2.)	Absolute value upper limit standby sequence ON			Absolute value alarm
11 (See note 2.)	Absolute value lower limit standby sequence ON			Absolute value alarm
12	Do not set.			

Note: 1. The default is 2.

2. Alarms with a Standby Sequence

The alarm is blocked until the first safe-state is reached.

Unwanted alarm during start-up are prevented.

Example: Deviation Lower Limit Standby Sequence ON

The standby sequence is cleared when the alarm OFF condition has been met.

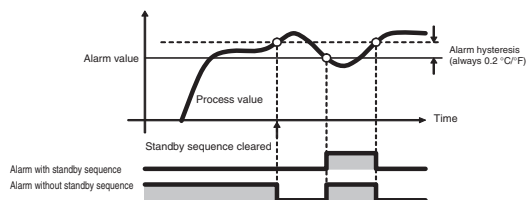

The standby sequence is started again when any of the following conditions is met.

- Operation is started (power is turned ON or operation is switched from stop to run).
- The alarm value is changed.
- The temperature input offset is changed.
- The set point is changed.

E5CB

Characteristics

Indication accuracy		Thermocouple: (See note 1.) ($\pm 0.5\%$ of indicated value or $\pm 1^\circ\text{C}$, whichever is greater) ± 1 digit max. Platinum resistance thermometer: ($\pm 0.5\%$ of indicated value or $\pm 1^\circ\text{C}$, whichever is greater) ± 1 digit max.
Influence of temperature (See note 2.)		R and S thermocouple inputs: ($\pm 1\%$ of PV or $\pm 10^\circ\text{C}$, whichever is greater) ± 1 digit max.
Influence of voltage (See note 2.)		K, J, and T thermocouple inputs: ($\pm 1\%$ of PV or $\pm 4^\circ\text{C}$, whichever is greater) ± 1 digit max. Platinum resistance thermometer inputs: ($\pm 1\%$ of PV or $\pm 2^\circ\text{C}$, whichever is greater) ± 1 digit max.
Hysteresis		0.1 to 999.9 (in units of 0.1) $^\circ\text{C}/^\circ\text{F}$
Proportional band (P)		0.1 to 999.9 (in units of 0.1) $^\circ\text{C}/^\circ\text{F}$
Integral time (I)		0 to 3999 s (in units of 1 s)
Derivative time (D)		0 to 3999 s (in units of 1 s)
Control period		0.5, 1 to 99 s (in units of 1 s)
Alarm setting range		-1999 to 9999 (decimal point position depends on input type)
Input sampling period		250 ms
Affect of signal source resistance		Thermocouple: $0.1^\circ\text{C}/\Omega$ max. (100 Ω max.) (See note 3.) Platinum resistance thermometer: $0.6^\circ\text{C}/\Omega$ max. (10 Ω max.)
Insulation resistance		20 M Ω min. (at 500 VDC)
Dielectric strength		2,300 VAC, 50 or 60 Hz for 1 min (between terminals with different charge)
Vibration resistance	Malfunction	10 to 55 Hz, 20 m/s ² for 10 min each in X, Y, and Z directions
	Destruction	10 to 55 Hz, 20 m/s ² for 2 hrs each in X, Y, and Z directions
Shock resistance	Malfunction	200 m/s ² , 3 times each in X, Y, and Z directions
	Destruction	300 m/s ² , 3 times each in X, Y, and Z directions
Weight		Controller: Approx. 100 g, Mounting Bracket: Approx. 10 g
Degree of protection		Front panel: IP66 Rear case: IP20, Terminals: IP00
Memory protection		Non-volatile memory (number of writes: 100,000 times)
Conformed standards	Certified standards	UL 61010-1, CSA C22.2 No. 1010-1
	Applicable standards	EN61326, EN61010-1, IEC61010-1 VDE0106, Part 100 (Finger protection), when the terminal cover is mounted.
EMC		EMI Emission Enclosure: EN61326 EN55011 Group1 Class A Emission AC Mains: EN55011 Group1 Class A EMS EN61326 Immunity ESD: EN61000-4-2 Immunity RF-interference: EN61000-4-3 Immunity Burst: EN61000-4-4 Conduction Disturbance Immunity: EN61000-4-6 Immunity Surge: EN61000-4-5 Immunity Voltage Dip/Interrupting: EN61000-4-11

Note: 1. The indication accuracy of K and T thermocouples at a temperature of -100°C max. is $\pm 2^\circ\text{C} \pm 1$ digit maximum. The indication accuracy of the R and S thermocouples at a temperature of 200°C max. is $\pm 3^\circ\text{C} \pm 1$ digit max.

2. Conditions: Ambient temperature: -10 to 23 to 55°C , Voltage range: -15% to $\pm 10\%$ of rated voltage

3. R, and S sensors: $0.2^\circ\text{C}/\Omega$ max. (100 Ω max.)

Electrical Life Expectancy Curve for Relays (Reference Values)

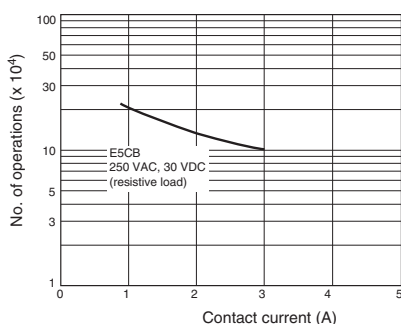

USB-Serial Conversion Cable Specifications

Applicable OS	Windows 2000, XP, Vista, or 7
Applicable software	Thermo Mini
Applicable models	E5CB Series
USB interface standard	USB specification 1.1
DTE speed	38,400 bps
Connector Specifications	Computer: USB (Type A plug) Temperature Controller: Special serial connector
Power supply	Bus power (supplied from the USB host controller)
Power supply voltage	5 VDC
Current consumption	450 mA max.
Output voltage	4.7 \pm 0.2 VDC (Supplied from USB-Serial Conversion Cable to the Temperature Controller.)
Output current	250 mA max. (Supplied from USB-Serial Conversion Cable to the Temperature Controller.)
Ambient temperature	0 to 55°C (with no condensation or icing)
Ambient humidity	10% to 80%
Storage temperature	-20 to 60°C (with no condensation or icing)
Storage humidity	10% to 80%
Altitude	2,000 m max.
Weight	Approx. 120 g

Note: 1. A high-power port is used for the USB port.
2. A driver must be installed on the computer. Refer to the *Instruction Manual* included with the Cable for the installation procedure.

External Connections

- A voltage output (control output) is not electrically insulated from the internal circuits. When using a grounding thermocouple, do not connect any of the control output terminals to ground. If the control output terminals are connected to ground, errors will occur in the measured temperature values as a result of leakage current.

E5CB

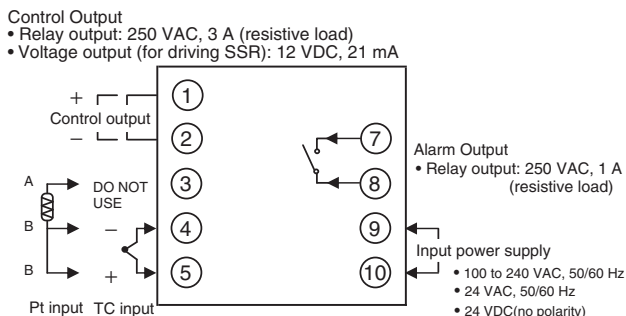

Nomenclature

E5CB

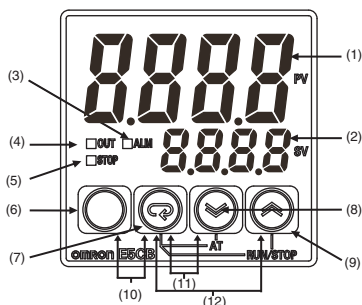

- | | | |
|-------------------|--|---|
| (1) Display No. 1 | Displays the process value (PV) or parameter. | (10) Press these keys for at least 3 seconds in Operation Level or Adjustment Level to go to Protect Level. Press these keys for at least 1 second in Protect Level to return to Operation Level. |
| (2) Display No. 2 | Displays the set point (SP) or parameter setting. | |
| (3) ALM | Lit while the alarm is ON. Not lit while the alarm is OFF. | |
| (4) OUT | Lit while the control output is ON. Not lit while the control output is OFF. | (11) Press these keys for at least 2 seconds to start or stop autotuning.*1 |
| (5) STOP | Not lit during operation. Lit while operation is stopped. | (12) Press these keys for at least 2 seconds to start or stop operation.*2 |
| (6) | Level Key: Changes the setting level. | *1: These keys are disabled when starting and stopping autotuning has been disabled with operation control key protection. |
| (7) | Mode Key: Changes the parameter within the setting level. | *2: These keys are disabled when starting and stopping operation has been disabled with operation control key protection. |
| (8) | Down Key: Reduces the setting. | |
| (9) | Up Key: Increases the setting. | |

Dimensions

(Unit: mm)

E5CB

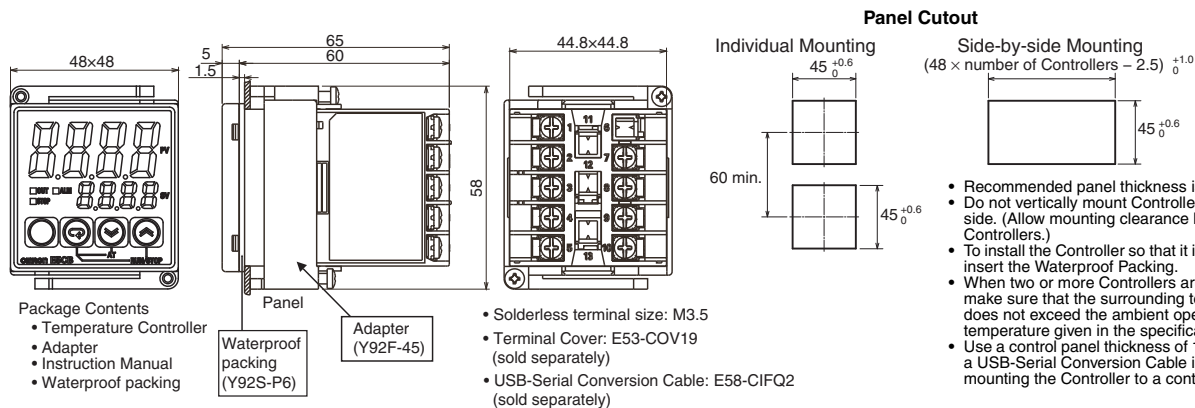

The Support Software port is on the top of the Temperature Controller. This port is used to connect the Temperature Controller to a personal computer. The E58-CIFQ2 USB-Serial Conversion Cable is required to make the connection. For details on connection methods, refer to the *E58-CIFQ2 USB-Serial Conversion Cable Instruction Manual*. *Do not leave the USB-Serial Conversion Cable connected while using the Temperature Controller.

E5CB

Accessories (Order Separately)

Terminal Cover E53-COV19

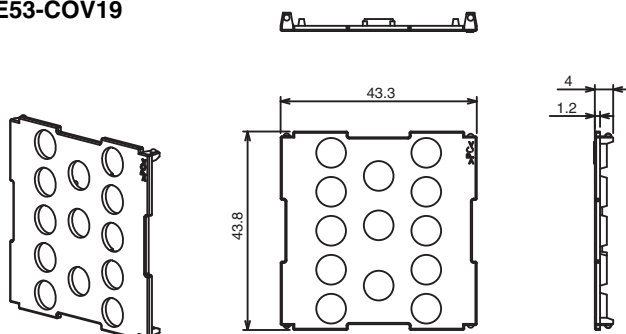

Note: The E53-COV10 cannot be used.

Waterproof Packing Y92S-P6

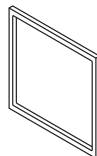

Order the Waterproof Packing separately if it becomes lost or damaged.
 The Waterproof Packing can be used to achieve an IP66 degree of protection.
 (Deterioration, shrinking, or hardening of the waterproof packing may occur depending on the operating environment. Therefore, periodic replacement is recommended to ensure the level of waterproofing specified in IP66. The time for periodic replacement depends on the operating environment. Be sure to confirm this point at your site. Consider one year a rough standard. OMRON shall not be liable for the level of water resistance if the customer does not perform periodic replacement.)
 The Waterproof Packing does not need to be attached if a waterproof structure is not required.

USB-Serial Conversion Cable E58-CIFQ2

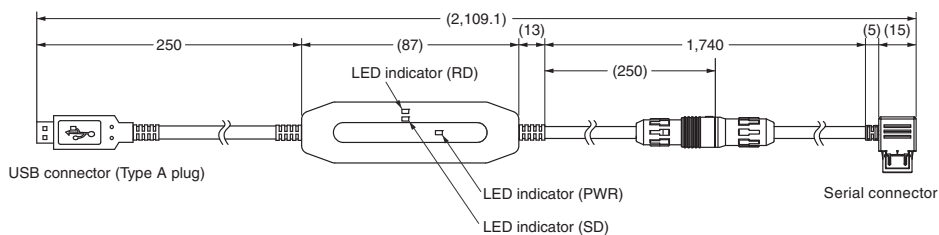

Operating Procedure

Parameters

Depending on the settings, some data may not be displayed.
 For details, refer to the *Instruction Manual*.
 Operation will stop when the level is switched from Operation Level to Initial Setting Level.

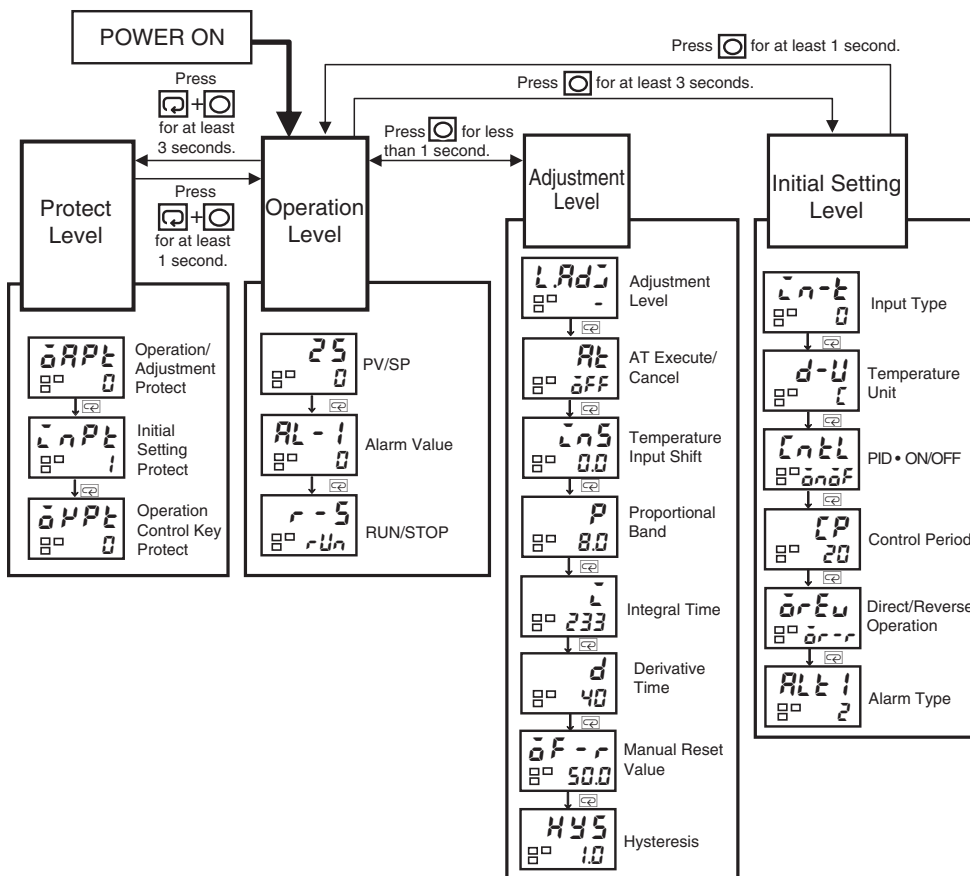

Troubleshooting

When an error has occurred, the display No.1 shows the error code.
 Take necessary measure according to the error code, referring the following table.

Display	Meaning	Action
S.ERR (S.ERR)	Input error*1	Check the wiring of inputs, disconnections, short circuits and input type.
E111 (E111)	RAM memory error	Turn the power OFF then back ON again.*2
E111/SUM (E111)/(SUM)*3	Non-volatile memory error	Press the \square and \square Keys for at least 3 seconds to initialize the settings and clear the non-volatile memory error.*2

- The control output and the alarm output will turn OFF when an error occurs. (For S.ERR, the alarm output will be processed for a high temperature error.)
 - If the input value exceeds the display limit (-1999 to 9999) but it is still within the control range, cccc will be displayed for values under -1999. Under these conditions, the control output and alarm output will operate normally.
- *1. This error is displayed only when the process value and set point are displayed.
 *2. If the display does not change, the Controller needs to be repaired.
 If operation returns to normal, then noise may have caused the problem. Check for noise.
 *3. E111 will be displayed on display No. 1 and SUM will be displayed on display No. 2.

E5CB**Warranty and Application Considerations****Read and Understand This Catalog**

Please read and understand this catalog before purchasing the products. Please consult your OMRON representative if you have any questions or comments.

Warranty and Limitations of Liability**WARRANTY**

OMRON's exclusive warranty is that the products are free from defects in materials and workmanship for a period of one year (or other period if specified) from date of sale by OMRON.

OMRON MAKES NO WARRANTY OR REPRESENTATION, EXPRESS OR IMPLIED, REGARDING NON-INFRINGEMENT, MERCHANTABILITY, OR FITNESS FOR PARTICULAR PURPOSE OF THE PRODUCTS. ANY BUYER OR USER ACKNOWLEDGES THAT THE BUYER OR USER ALONE HAS DETERMINED THAT THE PRODUCTS WILL SUITABLY MEET THE REQUIREMENTS OF THEIR INTENDED USE. OMRON DISCLAIMS ALL OTHER WARRANTIES, EXPRESS OR IMPLIED.

LIMITATIONS OF LIABILITY

OMRON SHALL NOT BE RESPONSIBLE FOR SPECIAL, INDIRECT, OR CONSEQUENTIAL DAMAGES, LOSS OF PROFITS, OR COMMERCIAL LOSS IN ANY WAY CONNECTED WITH THE PRODUCTS, WHETHER SUCH CLAIM IS BASED ON CONTRACT, WARRANTY, NEGLIGENCE, OR STRICT LIABILITY.

In no event shall the responsibility of OMRON for any act exceed the individual price of the product on which liability is asserted.

IN NO EVENT SHALL OMRON BE RESPONSIBLE FOR WARRANTY, REPAIR, OR OTHER CLAIMS REGARDING THE PRODUCTS UNLESS OMRON'S ANALYSIS CONFIRMS THAT THE PRODUCTS WERE PROPERLY HANDLED, STORED, INSTALLED, AND MAINTAINED AND NOT SUBJECT TO CONTAMINATION, ABUSE, MISUSE, OR INAPPROPRIATE MODIFICATION OR REPAIR.

Application Considerations**SUITABILITY FOR USE**

OMRON shall not be responsible for conformity with any standards, codes, or regulations that apply to the combination of products in the customer's application or use of the products.

Take all necessary steps to determine the suitability of the product for the systems, machines, and equipment with which it will be used.

Know and observe all prohibitions of use applicable to this product.

NEVER USE THE PRODUCTS FOR AN APPLICATION INVOLVING SERIOUS RISK TO LIFE OR PROPERTY WITHOUT ENSURING THAT THE SYSTEM AS A WHOLE HAS BEEN DESIGNED TO ADDRESS THE RISKS, AND THAT THE OMRON PRODUCTS ARE PROPERLY RATED AND INSTALLED FOR THE INTENDED USE WITHIN THE OVERALL EQUIPMENT OR SYSTEM.

Disclaimers**PERFORMANCE DATA**

Performance data given in this catalog is provided as a guide for the user in determining suitability and does not constitute a warranty. It may represent the result of OMRON's test conditions, and the users must correlate it to actual application requirements. Actual performance is subject to the OMRON *Warranty and Limitations of Liability*.

CHANGE IN SPECIFICATIONS

Product specifications and accessories may be changed at any time based on improvements and other reasons. Consult with your OMRON representative at any time to confirm actual specifications of purchased product.

DIMENSIONS AND WEIGHTS

Dimensions and weights are nominal and are not to be used for manufacturing purposes, even when tolerances are shown.

ALL DIMENSIONS SHOWN ARE IN MILLIMETERS.

To convert millimeters into inches, multiply by 0.03937. To convert grams into ounces, multiply by 0.03527.



SCATTERGOOD & JOHNSON LTD

ELECTRICAL ENGINEERING & FLUID CONTROL DISTRIBUTORS

Est.1899

At Scattergood & Johnson Ltd, we pride ourselves on being a technical distributor to specialist industries.

Working with a range of quality product suppliers across a number of specialist markets, we are not your average 'box shifter' - we are your technical and supply chain partner.

We fully support every product we sell - for free! Our internal team and external sales engineers can answer any product or application question, no matter the complexity.

Backing up this technical ability is a range of 50,000+ products available from stock for nationwide next day delivery (same day if required!), or you can collect what you need from any of our trade counters around the UK.

Select your specialist interest below to learn more about how we can help.



Online, In Branch and On the Road - Scattergood & Johnson Ltd, there when you need us.

www.scatts.co.uk