

# Modular Temperature Controller EJ1

## In-panel Temperature Controller with Flexible Modular Design and Wide Integration with Host Devices

- The compact modular structure enables construction of temperature systems optimally suited to the application.
- Connection can be made to a Programmable Controller without any programming required, reducing the number of steps required in ladder programming design.
- One fully universal-input Unit includes a thermocouple, platinum-resistance thermometer, and analog input for easy selection and reduced inventory requirements.
- Connect directly to the G3ZA Multi-channel Power Controller using optimum cycle control for high-accuracy regulation with minimal noise.
- Autotuning (AT) can be used for independent heating/cooling PID control, and self-tuning (ST) can be used to calculate the PID constants with the step response method.
- Up to 16 Temperature Controllers can be connected to a single DeviceNet Communications Unit.

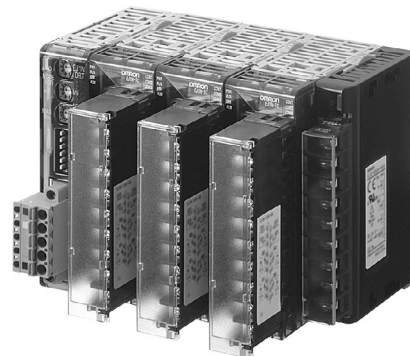

Supports DeviceNet Communications.

Refer to the *Safety Precautions* on page 21.

## Ordering Information

### Temperature Controller Standard Control Models

Name	Power supply voltage	No. of control points	Control outputs 1 and 2	Control outputs 3 and 4	Auxiliary output	Functions		Communications functions	Input type	Terminal	Model
						Heater burnout alarm	Event inputs				
Basic Unit (temperature control) (See note 1.) <b>V1.2</b>	24 VDC supplied from the End Unit	2	Voltage output: 2 points (for SSR drive) (See note 2.)	Transistor output: 2 points (sinking)	None	2 (See note 3.)	2	G3ZA connection port: RS-485 From End Unit: Port A or port B: RS-485	Thermocouple, platinum resistance thermometer, analog voltage, and analog current selectable for each channel.	M3 terminal	EJ1N-TC2A-QNHB
										Screw-less clamp	EJ1N-TC2B-QNHB
										M3 terminal	EJ1N-TC4A-QQ
										Screw-less clamp	EJ1N-TC4B-QQ
HFU with Programmless Communications (See note 1.) <b>V1.2</b>	None	None	None	None	Transistor output: 4 points (sinking)	4	Port C: RS-485 or RS-232C selectable.  From End Unit: Port A: RS-485  Port C: RS-422  From End Unit: Port A: RS-485	No input	M3 terminal	EJ1N-HFUA-NFLK	
									Screw-less clamp	EJ1N-HFUB-NFLK	
									M3 terminal	EJ1N-HFUA-NFL2	
									Screw-less clamp	EJ1N-HFUB-NFL2	
HFU with DeviceNet Communications (See note 1.)	24 VDC	None	None	None	None	None	DeviceNet communications	Screw-less clamp	Screw-less clamp	EJ1N-HFUB-DRT	
End Unit (See note 1.)									Transistor output: 2 points (sinking)	None	Port A or B: RS-485 Connector: Port A
									Detachable connector	EJ1C-EDUC-NFLK	

**Note:** 1. An End Unit is always required for connection to a Basic Unit or an HFU. An HFU cannot operate without a Basic Unit. External communications cannot be performed when using a Basic Unit only.  
 2. For heating/cooling control applications, control outputs 3 and 4 on the 2-point models are used for the cooling or heating control outputs. On the 4-point models, heating/cooling control is performed for the two input points.  
 3. When using the heater burnout alarm, purchase a Current Transformer (E54-CT1 or E54-CT3) separately.

### Functional Upgrades

Refer to page 18 for details.

Upgrade functions are supported by the indicated version ("V1.1" or "V1.2") or a higher version of the software.

Refer to the following manual for precautionary information and other information necessary to use the EJ1:  
**EJ1 Modular Temperature Controller User's Manual (Cat. No. H142)**

## ■ Accessories (Order Separately)

### Current Transformer (CT)

Diameter	Model
5.8 dia.	E54-CT1
12.0 dia.	E54-CT3

### G3ZA Connecting Cable

Cable length	Model
5 m	EJ1C-CBLA050

### Rail Mounting Equipment

Name	Model
Mounting Rail	PFP-100N
	PFP-50N

### CX-Thermo Support Software Ver. 4.1

Model
EST2-2C-MV4

### USB-Serial Conversion Cable

Model
E58-CIFQ1

## Specifications

### Basic Unit/EJ1N-TC

## ■ Ratings

Item	Type	EJ1N-TC4	EJ1N-TC2
Power supply voltage		24 VDC	
Operating voltage range		85% to 110% of rated voltage	
Power consumption		5 W max. (at maximum load)	4 W max. (at maximum load)
Input (See note.)		Thermocouple: K, J, T, E, L, U, N, R, S, B, W, PLII ES1B Infrared Thermosensor: 10 to 70°C, 60 to 120°C, 115 to 165°C, 140 to 260°C Analog input: 4 to 20 mA, 0 to 20 mA, 1 to 5 V, 0 to 5 V, 0 to 10 V Platinum resistance thermometer: Pt100, JPt100	
Input impedance		Current input: 150 Ω max., voltage input: 1 MΩ min.	
Control outputs	Voltage output	Output voltage: 12 VDC ±15%, max. load current: 21 mA (PNP models with short-circuit protection circuit)	
	Transistor output	---	Max. operating voltage: 30 V, max. load current: 100 mA
	Current output	---	Current output range: 4 to 20 mA or 0 to 20 mA DC Load: 500 Ω max. (including transfer output) (Resolution: Approx. 2,800 for 4 to 20 mA DC, approx. 3,500 for 0 to 20 mA DC)
Event inputs	Input points	---	2
	Contact input	---	ON: 1 kΩ max., OFF: 100 kΩ min.
	Non-contact input	---	ON: Residual voltage: 1.5 V max., OFF: Leakage current: 0.1 mA max.
		---	Outflow current: Approx. 4 mA per point
Number of input and control points		Input points: 4, Control points: 4	Input points: 2, Control points: 2
Setting method		Via communications	
Control method		ON/OFF control or 2-PID (with autotuning, self-tuning) <b>V1.2</b>	
Other functions		Two-point input shift, digital input filter, remote SP, SP ramp, manual manipulated variable, manipulated variable limiter, interference overshoot adjustment, loop burnout alarm, RUN/STOP, banks, I/O allocations, etc.	
Ambient temperature range		Operating: -10°C to 55°C, Storage: -25°C to 65°C (with no icing or condensation)	
Ambient humidity range		Operating: 25% to 85% (with no condensation)	

**Note:** Inputs are fully universal. Therefore, platinum resistance thermometer, thermocouple, infrared thermosensor, and analog input can be selected.

## ■ Characteristics

<b>Indication accuracy</b>	Thermocouple input/platinum resistance thermometer input: (±0.5% of indication value (PV) or ±1°C, whichever is greater) ±1 digit max. (See note 1.) Analog input: ±0.5% FS ±1 digit max. CT input: ±5% FS ±1 digit max.																				
<b>Hysteresis</b>	0.1 to 999.9 EU (in units of 0.1 EU) (See note 2.)																				
<b>Proportional band (P)</b>	0.1 to 999.9 EU (in units of 0.1 EU) (See note 2.)																				
<b>Integral time (I)</b>	0 to 3,999 s (in units of 1 s)																				
<b>Derivative time (D)</b>	0.0 to 999.9 s (in units of 0.1 s)																				
<b>Control period</b>	0.5 s, 1 to 99 s (in units of 1 s)																				
<b>Manual reset value</b>	0.0% to 100.0% (in units of 0.1%)																				
<b>Alarm setting range</b>	-1,999 to 9,999 (decimal point position depends on input type)																				
<b>Sampling period</b>	250 ms																				
<b>Influence of signal source resistance</b>	Thermocouple: 0.1°C (0.2°F)/Ω max. (100 Ω max per line) (See note 3.) Platinum resistance thermometer: 0.4°C (0.8°F)/Ω max. (10 Ω max per line)																				
<b>Insulation resistance</b>	20 MΩ min. (at 500 VDC)																				
<b>Dielectric strength</b>	600 VAC, 50/60 Hz for 1 min between current-carrying terminals of different polarity																				
<b>Vibration resistance</b>	10 to 55 Hz, 20 m/s <sup>2</sup> for 2 hours each in X, Y, and Z directions																				
<b>Shock resistance</b>	150 m/s <sup>2</sup> , 3 times each in 6 directions																				
<b>Weight</b>	180 g																				
<b>Degree of protection</b>	Rear case: IP20, Terminal section: IP00																				
<b>Memory protection</b>	EEPROM (non-volatile memory) (number of writes: 100,000)																				
<b>Standards</b>	<b>Approved standards</b>																				
	<b>Conformed standards</b>																				
<b>EMC Directive</b>	<table> <tr> <td>EMI:</td> <td>EN61326</td> </tr> <tr> <td>EMI Radiated:</td> <td>EN55011 Group1 class A</td> </tr> <tr> <td>EMI Conducted:</td> <td>EN55011 Group1 class A</td> </tr> <tr> <td>EMS:</td> <td>EN61326</td> </tr> <tr> <td>ESD Immunity:</td> <td>EN61000-4-2</td> </tr> <tr> <td>Electromagnetic Field Immunity:</td> <td>EN61000-4-3</td> </tr> <tr> <td>Burst immunity/Noise Immunity:</td> <td>EN61000-4-4</td> </tr> <tr> <td>Conducted Disturbance Immunity:</td> <td>EN61000-4-6</td> </tr> <tr> <td>Surge Immunity:</td> <td>EN61000-4-5</td> </tr> <tr> <td>Power Frequency Magnetic Field Immunity:</td> <td>EN61000-4-8</td> </tr> </table>	EMI:	EN61326	EMI Radiated:	EN55011 Group1 class A	EMI Conducted:	EN55011 Group1 class A	EMS:	EN61326	ESD Immunity:	EN61000-4-2	Electromagnetic Field Immunity:	EN61000-4-3	Burst immunity/Noise Immunity:	EN61000-4-4	Conducted Disturbance Immunity:	EN61000-4-6	Surge Immunity:	EN61000-4-5	Power Frequency Magnetic Field Immunity:	EN61000-4-8
EMI:	EN61326																				
EMI Radiated:	EN55011 Group1 class A																				
EMI Conducted:	EN55011 Group1 class A																				
EMS:	EN61326																				
ESD Immunity:	EN61000-4-2																				
Electromagnetic Field Immunity:	EN61000-4-3																				
Burst immunity/Noise Immunity:	EN61000-4-4																				
Conducted Disturbance Immunity:	EN61000-4-6																				
Surge Immunity:	EN61000-4-5																				
Power Frequency Magnetic Field Immunity:	EN61000-4-8																				

- Note:** 1. The indication of K thermocouples in the -200 to 1,300°C range, T and N thermocouples at a temperature of -100°C or less, and U and L thermocouples at any temperature is ±2°C ±1 digit maximum. The indication of B thermocouples at a temperature of 400°C or less is unrestricted. The indication of R and S thermocouples at a temperature of 200°C or less is ±3°C ±1 digit max.  
W = (±0.5% of indication value (PV) or ±3°C, whichever is greater) ±1 digit max. PLII = (±0.5% of indication value (PV) or ±2°C, whichever is greater) ±1 digit max.  
The indication accuracy for K thermocouples in the -199.9 to 999.9°C range **V1.2** is (±0.5% of indication value (PV) or ±1°C, whichever is greater) ±10 digit maximum. However, at a temperature of -100°C or less, it is ±2°C ±10 digit maximum.
2. "EU" stands for Engineering Unit. The location of the decimal point depends on the type of sensor that is selected.  
If the decimal point locations is set to 0 (\*\*\*\*), however, it will be treated as if it were set to 1 (\*\*\*.\*).
3. B, R, S, and W sensors: 0.2°C/Ω max. (100 Ω max.)

## ■ Communications Specifications

Item	Port B (See note 1.)	Port A Terminal/ Port A Connector (See note 1.)	G3ZA Connection Port (See note 2.)
Transmission path connection	RS-485 (multipoint)		
Communications method	RS-485 (two-wire, half duplex)		
Synchronization method	Start-stop synchronization		
Communications protocol	CompoWay/F, Modbus (See note 4.) V1.1	CompoWay/F	
Baud rate	9.6, 19.2, 38.4, 57.6, or 115.2 kbps	38.4 kbps fixed	57.6 kbps fixed
Transmission code	CompoWay/F: ASCII, Modbus: RTU	CompoWay/F: ASCII	
Data bit length	7 or 8 bits	7 bits	
Stop bit length	1 or 2 bits	2 bits	
Error detection	Vertical parity (none, even, or odd)	Vertical parity (even)	
	Block check character (BCC): with CompoWay/F, CRC-16: (with Modbus)		
Flow control	None		
Interface	RS-485		
Retry function	None		
Communications response wait time	0 to 99 ms (default: 5 ms) V1.1	1 to 99 ms (default: 1 ms)	---
Number of Units that can be connected in parallel (See note 3.)	64 Units (model numbers with TC4: 256 channels, model numbers with TC2: 128 channels) Communications connection via port B on the End Unit	64 Units (model numbers with TC4: 256 channels, model numbers with TC2: 128 channels) Communications connection via port A on the End Unit	8 Units (Communications connection via G3ZA port on the Basic Unit)

**Note:** 1. Connection from the EJ1C-EDU. When using an HFU, port B on the End Unit can be used for distributed placement only.

2. A special cable (EJ1C-CBLA050) must be purchased separately for the G3ZA connection.

3. For the number of Units that can be connected, refer to *Connection Precautions* on page 11.

4. The Modbus protocol can be used with Basic Unit with version 1.1 or higher.

## ■ Current Transformer (CT) Rating

Dielectric strength	1,000 VAC for 1 min
Vibration resistance	50 Hz, 98 m/s <sup>2</sup>
Weight	E54-CT1: Approx. 11.5 g, E54-CT3: Approx. 50 g
Accessories (E54-CT3 only)	Armatures (2), plugs (2)

## ■ Characteristics of the Heater Burnout Alarm, SSR Failure Alarm, and Heater Overcurrent Alarm (TC2□-QNHB Model Only)

Maximum heater current	100 VAC
Input current indication accuracy	±5%FS ±1 digit max.
Heater burnout alarm setting range	0.1 to 99.9 A (in units of 0.1 A) 0.0 A: Heater burnout alarm output turns OFF. 100.0 A: Heater burnout alarm output turns ON. Min. detection ON time: 100 ms (See note 1.)
SSR failure alarm setting range	0.1 to 99.9 A (in units of 0.1 A) 0.0 A: SSR failure alarm output turns ON. 100.0 A: SSR alarm output turns OFF. Min. detection OFF time: 100 ms (See note 2.)
Heater overcurrent alarm setting range	0.1 to 99.9 A (in units of 0.1 A) 0.0 A: Heater overcurrent alarm output turns ON. 100.0 A: Heater overcurrent alarm output turns OFF. Min. detection ON time: 100 ms (See note 1.)

**Note:** 1. When the control output ON time is less than 100 ms, heater burnout detection, heater overcurrent detection, and heater current measurement are not performed.

2. When the control output OFF time is less than 100 ms, SSR failure alarm and leakage current measurement are not performed.

## Input Ranges

Sensor inputs are fully universal. Therefore, platinum resistance thermometer, thermocouple, infrared thermosensor, and analog input can be selected.

Inputs can be set for each channel using universal inputs.

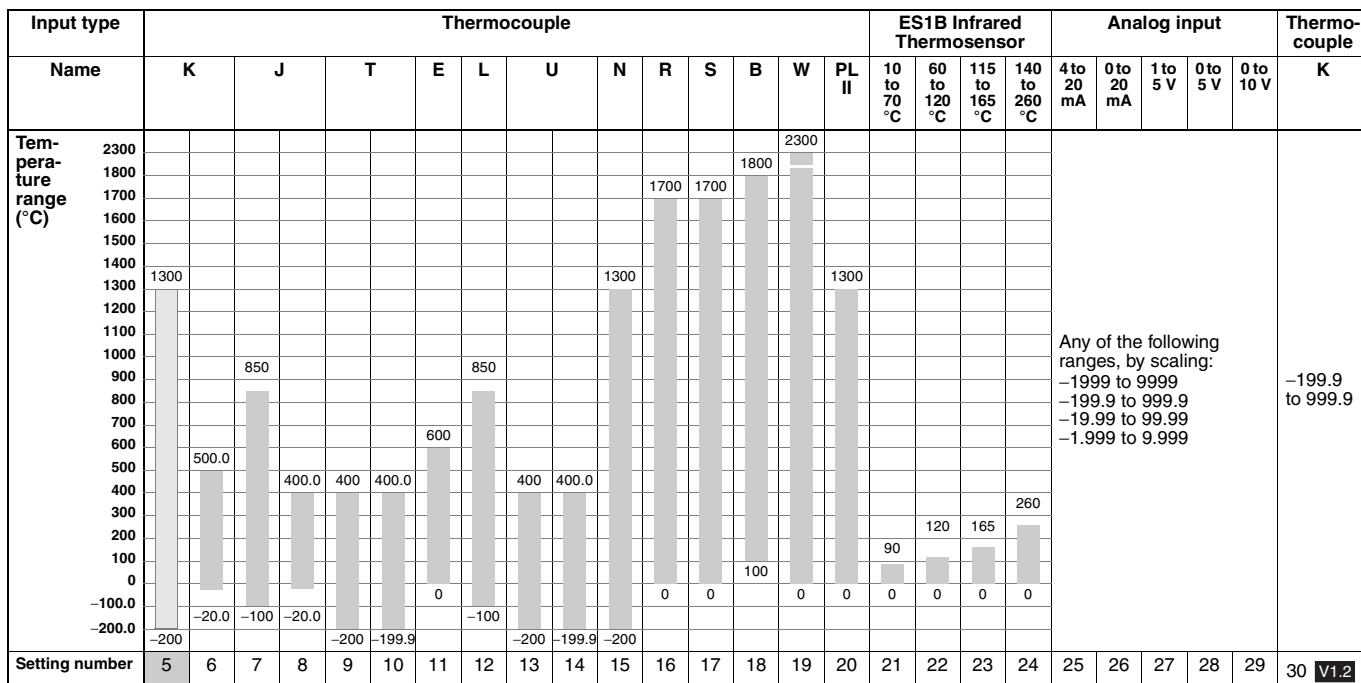
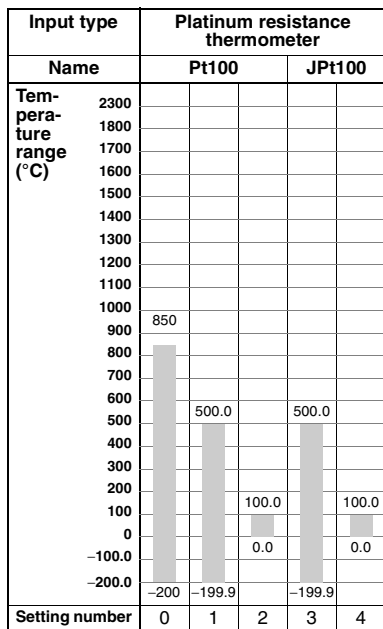

Applicable standards by input type are as follows:

K, J, T, E, N, R, S, B: JIS C1602-1995, IEC584-1

L: Fe-CuNi, DIN 43710-1985

U: Cu-CuNi, DIN 43710-1985

W: W5Re/W26Re, ASTM E988-1990

PL II: According to Platine II Electromotive Force Table by Engelhard Corp.

JPt100: JIS C 1604-1989, JIS C 1606-1989

Pt100: JIS C 1604-1997 IEC 751

<b>HFU Unit/EJ1N-HFU□-NFL□</b>
--------------------------------

## ■ Ratings

Power supply voltage		24 VDC
Operating voltage range		85% to 110% of rated voltage
Power consumption		2 W max. (at maximum load)
Auxiliary outputs (See note.)	Outputs	4
	Transistor outputs	Max. operating voltage: 30 VDC, Max. load current: 50 mA
Event inputs	Inputs	4
	Contact inputs	ON: 1 kΩ max., OFF: 100 kΩ min.
	Transistor inputs	ON: residual voltage of 1.5 max., OFF: leakage current of 0.1 mA max. Outflow current: Approx. 4 mA (per contact)
Programless connection	Downloading (EJ1 reads data from a PLC)	Number of parameters that can be set: 1200 <b>V1.2</b>
	Uploading (EJ1 writes data to a PLC)	Number of parameters that can be set: 1200 <b>V1.2</b>
	Applicable PLCs	OMRON: SYSMAC CS/CJ/CP Series Mitsubishi Electric: MELSEC-An/AnS/FX <sub>3UC</sub> Series <b>V1.1</b> Mitsubishi Electric: MELSEC-Q/QnA/QnAS Series
Ambient temperature range		Operating: -10°C to 55°C Storage: -25°C to 65°C (with no icing or condensation)
Ambient humidity range		Operating: 25% to 85% (with no condensation)

Note: Auxiliary outputs can be allocated using digital output allocations.

## ■ Characteristics

Insulation resistance		20 MΩ min. (at 500 VDC)
Dielectric strength		600 VAC, 50/60 Hz for 1 min between current-carrying terminals of different polarity
Vibration resistance		10 to 55 Hz, 20 m/s <sup>2</sup> for 2 hours each in X, Y, and Z directions
Shock resistance		150 m/s <sup>2</sup> , 3 times each in 6 directions
Weight		160 g
Degree of protection		Rear case: IP20, Terminal section: IP00
Memory protection		EEPROM (non-volatile memory) (number of writes: 100,000)
Standards	Approved standards	UL61010C-1, CSA C22.2 No.1010-1
	Conformed standards	EN61010-1 (IEC61010-1): Pollution level 2, overvoltage category II
EMC Directive		Refer to page 3.

## ■ Communications Characteristics: Port C

Transmission path connection		RS-485/RS-422: Multi-point, RS-232C: Point-to-point (See note 1.)
Communications method		RS-485/RS-422 (two-wire, half duplex), RS-232C
Synchronization method		Start-stop synchronization
Communications protocol		<ul style="list-style-type: none"> <li>• OMRON PLC protocol (Connectable PLCs: SYSMAC CS/CJ/CP Series)</li> <li>• AnA/AnU CPU common commands (Connectable PLCs: MELSEC-An/AnS/FX<sub>3UC</sub> Series) <b>V1.1</b></li> <li>• MC protocol (form 5) (Connectable PLCs: MELSEC-Q/QnA/QnAS Series)</li> </ul>
Baud rate		9.6, 19.2, 38.4, 57.6, or 115.2 kbps
Transmission code		Binary
Data bit length		8 bits
Stop bit length		1 bit
Error detection		Depends on protocol selected for the programless communications protocol.
Flow control		None
Interface		RS-485, RS-422, RS-232C (See note 1.)
Retry function		Available
Communications response wait time		0 to 99 ms (default: 5 ms) <b>V1.1</b>
Number of Basic Units that can be connected in parallel (See note 2.)		32 Units (model numbers with TC4:128 channels max., model numbers with TC2:64 channels max.)
Number of HFUs that can be connected <b>V1.1</b>		<ul style="list-style-type: none"> <li>• SYSMAC CS/CJ/CP-series PLCs: 8 (EJ1-HFU□-NFLK)</li> <li>• MELEC Q/QnA/QnAS-series PLCs: 8 (EJ1-HFU□-NFL2)</li> </ul>

Note: 1. The communications method can be switched between RS-485 and RS-232C. A separate model must be used for RS-422 communications.  
2. For the number of Units that can be connected, refer to *Connection Precautions* on page 11.

<b>HFU Unit/EJ1N-HFUB-DRT</b>
-------------------------------

## ■ Ratings

Power supply voltage	DeviceNet power supply	24 VDC (for internal circuits)
	EDU power supply	24 VDC (for RS-485 communications circuits and Temperature Controllers)
Operating voltage range	DeviceNet power supply	11 to 25 VDC
	EDU power supply	20.4 to 26.4 VDC
Power consumption	1 W max. (at maximum load)	
Main functions	Remote I/O communications, explicit message communications, CompoWay/F command feed-through function, parameter backup function, and configuration registration	
Ambient temperature range	Operating: -10°C to 55°C Storage: -25°C to 65°C (with no icing or condensation)	
Ambient humidity range	Operating: 25% to 85% (with no condensation)	

## ■ Characteristics

Insulation resistance	20 M $\Omega$ min. (at 500 VDC)	
Dielectric strength	600 VAC, 50/60 Hz for 1 min	
Vibration resistance	10 to 55 Hz, 10 m/s <sup>2</sup> for 2 hours each in X, Y, and Z directions	
Shock resistance	150m/s <sup>2</sup> max. 3 times each in 3 axes, 6 directions	
Weight	70 g max.	
Degree of protection	IP20	
Memory protection	EEPROM, 100,000 write operations (backup data)	
Standards	Approved standards	UL61010-1, CSA C22.2 No.1010-1
	Conformed standards	EN61010-1 (IEC61010-1): Pollution level 2, overvoltage category II
EMC Directive	Refer to page 3.	

## ■ Communications Characteristics

Communications protocol	Conforms to DeviceNet.																		
Communications functions	Remote I/O communications	Master-slave connections (polling, COS, or cyclic) Conforms to DeviceNet specifications.																	
	I/O allocation	Input and output data can be allocated freely by user with the Configurator. Allocations can be made to DeviceNet parameters or Temperature Controller parameters. Two blocks for IN Area, up to 100 words One block for OUT Area, up to 100 words (The first word is always allocated to the OUT Enable Bit.)																	
	Message communications	Explicit message communications CompoWay/F communications commands can be sent (commands are sent in explicit message format).																	
Connection format	Combination of multidrop and T-branch connections (for trunk and drop lines)																		
Baud rate	DeviceNet: 500, 250, or 125 kbps, or automatic detection of master baud rate																		
Communications media	Special 5-wire cable (2 signal lines, 2 power lines, and 1 shield line)																		
Communications distance	<table border="1"> <thead> <tr> <th>Baud rate</th> <th>Network length</th> <th>Drop line length</th> <th>Total drop line length</th> </tr> </thead> <tbody> <tr> <td>500 kbps</td> <td>100 m max. (100 m max.)</td> <td>6 m max.</td> <td>39 m max.</td> </tr> <tr> <td>250 kbps</td> <td>250 m max. (100 m max.)</td> <td>6 m max.</td> <td>78 m max.</td> </tr> <tr> <td>125 kbps</td> <td>500 m max. (100 m max.)</td> <td>6 m max.</td> <td>156 m max.</td> </tr> </tbody> </table> <p>The values in parentheses apply when Thin Cables are used.</p>			Baud rate	Network length	Drop line length	Total drop line length	500 kbps	100 m max. (100 m max.)	6 m max.	39 m max.	250 kbps	250 m max. (100 m max.)	6 m max.	78 m max.	125 kbps	500 m max. (100 m max.)	6 m max.	156 m max.
Baud rate	Network length	Drop line length	Total drop line length																
500 kbps	100 m max. (100 m max.)	6 m max.	39 m max.																
250 kbps	250 m max. (100 m max.)	6 m max.	78 m max.																
125 kbps	500 m max. (100 m max.)	6 m max.	156 m max.																
Communications power supply	11 to 25 VDC																		
Maximum number of nodes that can be connected	64 (includes Configurator when used.)																		
Maximum number of slaves that can be connected	63																		
Error control	CRC error detection																		
DeviceNet power supply	Power supplied from DeviceNet communications connector																		
Applicable Temperature Controllers	EJ1 Series (excluding the EJ1G) TC4: EJ1N-TC4A-QQ and EJ1N-TC4B-QQ TC2: EJ1N-TC2A-QNHB, EJ1N-TC2B-QNHB, EJ1N-TC2A-CNB, and EJ1N-TC2B-CNB																		
Maximum number of Temperature Controllers that can be connected (See note.)	16 Units (model numbers with TC4: 64 channels max., model numbers with TC2: 32 channels max.)																		

**Note:** For the number of Units that can be connected, refer to *Connection Precautions* on page 11.

<b>End Unit/EJ1C-EDU</b>
--------------------------

## ■ Ratings

<b>Power supply voltage</b>	24 VDC	
<b>Operating voltage range</b>	85% to 110% of rated voltage	
<b>Auxiliary output (See note.)</b>	<b>Outputs</b>	2
	<b>Transistor outputs</b>	Max. operating voltage: 30 VDC, Max. load current: 50 mA
<b>Ambient temperature range</b>	Operating: -10°C to 55°C Storage: -25°C to 65°C (with no icing or condensation)	
<b>Ambient humidity range</b>	Operating: 25% to 85% (with no condensation)	

**Note:** Auxiliary output can be allocated using the bus output allocation for each Basic Unit.

## ■ Characteristics

<b>Insulation resistance</b>	20 MΩ min. (at 500 VDC)	
<b>Dielectric strength</b>	600 VAC, 50/60 Hz for 1 min between current-carrying terminals of different polarity	
<b>Vibration resistance</b>	10 to 55 Hz, 20 m/s <sup>2</sup> for 2 hours each in X, Y, and Z directions	
<b>Shock resistance</b>	150 m/s <sup>2</sup> , 3 times each in 6 directions	
<b>Weight</b>	70 g	
<b>Degree of protection</b>	End Unit case: IP20, Terminal section: IP00	
<b>Standards</b>	<b>Approved standards</b>	UL61010C-1, CSA C22.2 No.1010-1
	<b>Conformed standards</b>	EN61010-1 (IEC61010-1): Pollution level 2, overvoltage category II
<b>EMC Directive</b>	Same as for the Basic Unit. Refer to page 3.	

## ■ Communications

<b>Port B (See note 1.)</b>	Basic Unit Communications (Refer to <i>Communications Specifications</i> on page 4.)
<b>Port A</b>	Basic Unit Communications (Refer to <i>Communications Specifications</i> on page 4.)
<b>Port A connector (See note 2.)</b>	E58-CIFQ1

**Note:** 1. Port B communications for the End Unit cannot be used when port C communications for the HFU is used.  
2. Port A connector communications and port A terminal communications cannot be used at the same time.

# Unit Configuration Example

## Minimal Configuration

### Small Systems with 2 Channels or 4 Channels Communicating with the Host Device via RS-485 (CompoWay/F Protocol)

- Alarms can be allocated to the auxiliary output for the End Unit.
- G3ZA/G3PW outputs can be used.

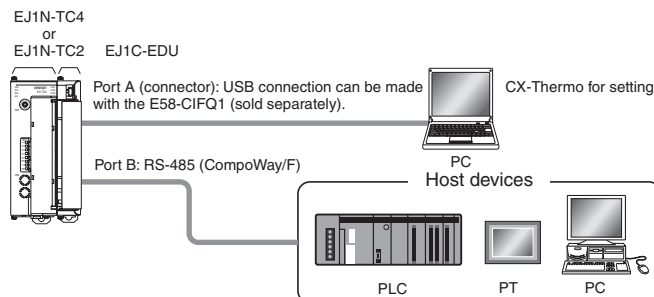

## Multiple Units without an EJ1N-HFU

### Building Systems Communicating with the Host Device, such as a PLC, PT, or Computer, via RS-485 (CompoWay/F Protocol)

- The 2 auxiliary alarm outputs provided on the End Unit can be used for integrated alarm systems.
- G3ZA/G3PW outputs can be used.
- Distributed placement is possible by using multiple EJ1C-EDU End Units.

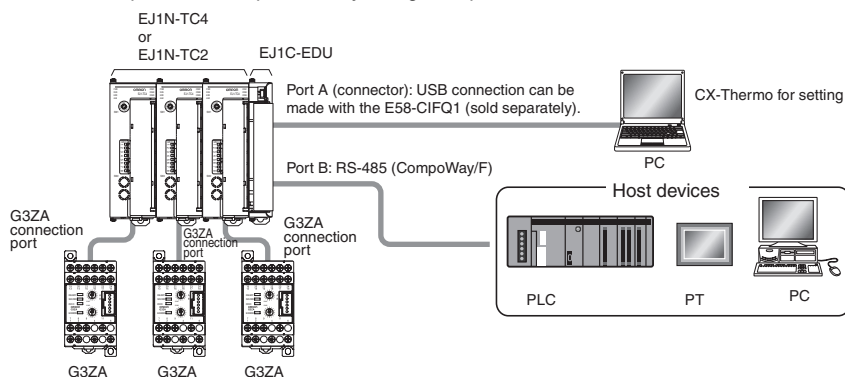

## Multiple Units with an EJ1N-HFU

### Using the EJ1N-HFU□-NFL□ to Build a System Communicating 1:1 with a PLC Using Programless Communications

- The 2 auxiliary outputs provided on the End Unit can be used.
- The 4 event inputs and 4 auxiliary outputs of the HFU can also be used.
- G3ZA/G3PW outputs can be used.
- Distributed placement is possible by using multiple EJ1C-EDU End Units

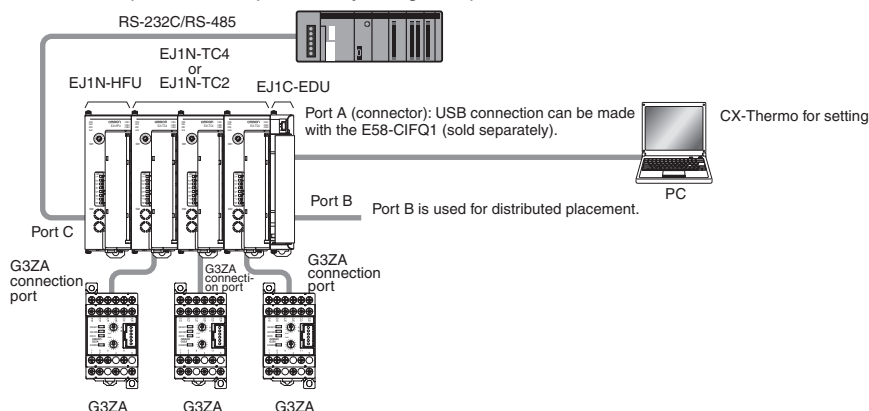

## ■ Multiple Units with an EJ1N-HFU

### Using the EJ1N-HFU□-NFL□ to Build Systems Communicating 1:1 with a PLC

#### Using Programless Communications V1.1

- Up to eight HFUs can be connected to one port on a PLC.
- G3ZA/G3PW outputs can be used.
- Distributed placement is possible by using multiple EJ1C-EDU End Units.
- To connect more than one HFU, specific PLC and EJ1 models must be used. Refer to *Connecting EJ1 Controllers 1:N to a PLC* on page 13.

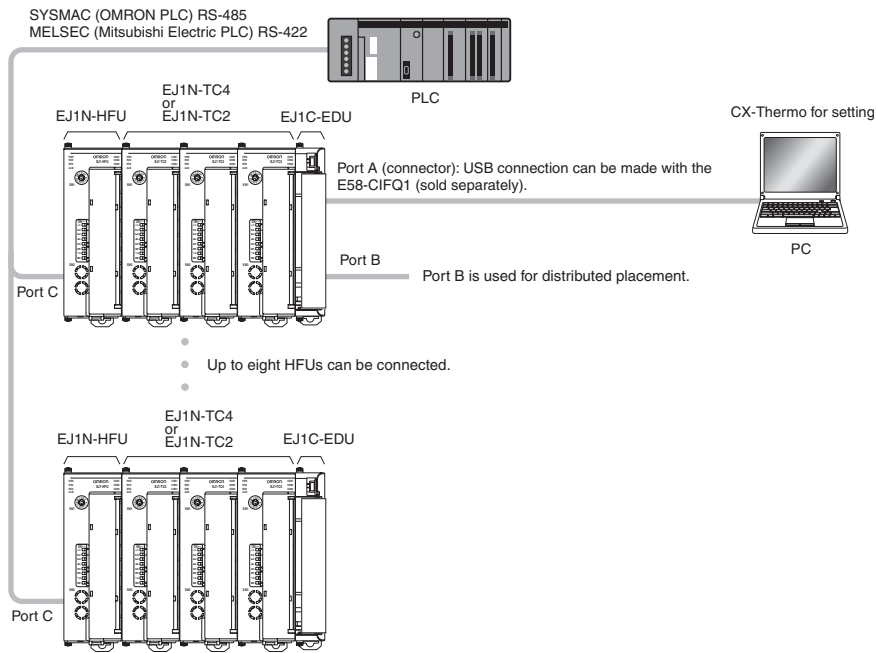

Note: Set the EJ1N-TC to a communications unit number that is not being used by the EJ1N-HFU.

## ■ Multiple Units with an EJ1N-HFU

### Using the EJ1N-HFUB-DRT to Build a System Communicating with a PLC

- Up to 63 DeviceNet slaves can be connected to the DeviceNet Masters in one PLC.
- G3ZA/G3PW outputs can be used.
- Distributed placement is possible by using multiple EJ1C-EDU End Units.

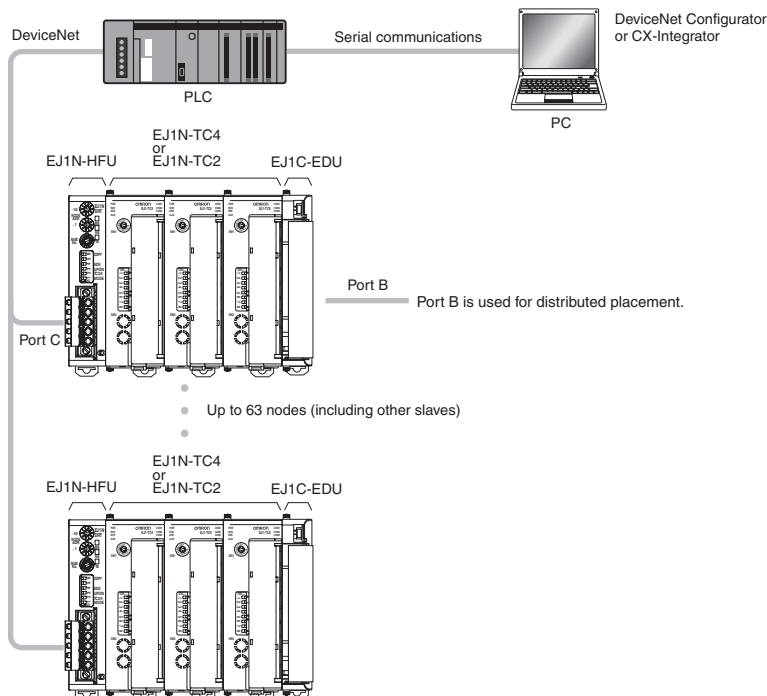

## ■ Connection Precautions

### Communications Unit Number Setting

- Communications unit numbers 0 to 63 can be assigned to Basic Units and HFUs.

### Restrictions on the Number of Units That Can Be Connected

#### Restrictions for HFUs

- One EJ1N-HFU can manage up to 32 Basic Units (EJ1N-TC4/TC2).
- Up to 16 Units can be connected side by side including the EJ1N-HFU. The End Unit is not included in the 16 Units.

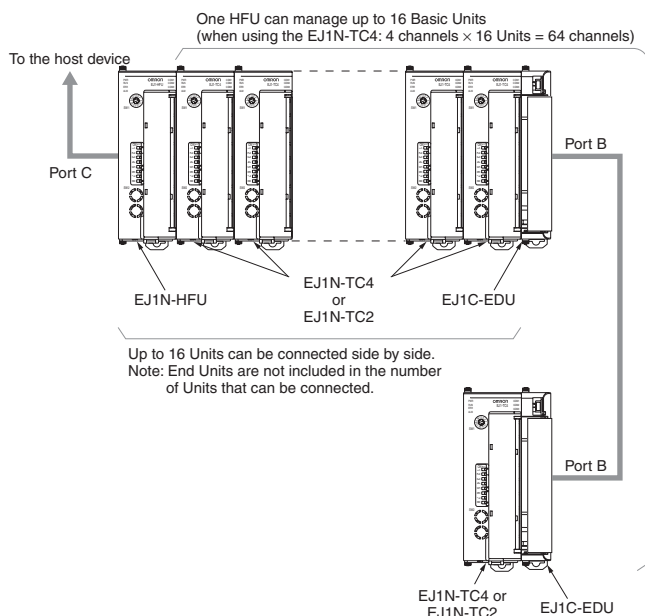

#### Restrictions for Basic Units

- When the system is configured of only Basic Units (EJ1N-TC4/TC2), up to 64 Units can be connected.
- Distributed placement is possible by using End Units (EJ1C-EDU).
- Up to 16 Units can be connected side by side. The End Unit is not included in the 16 Units.

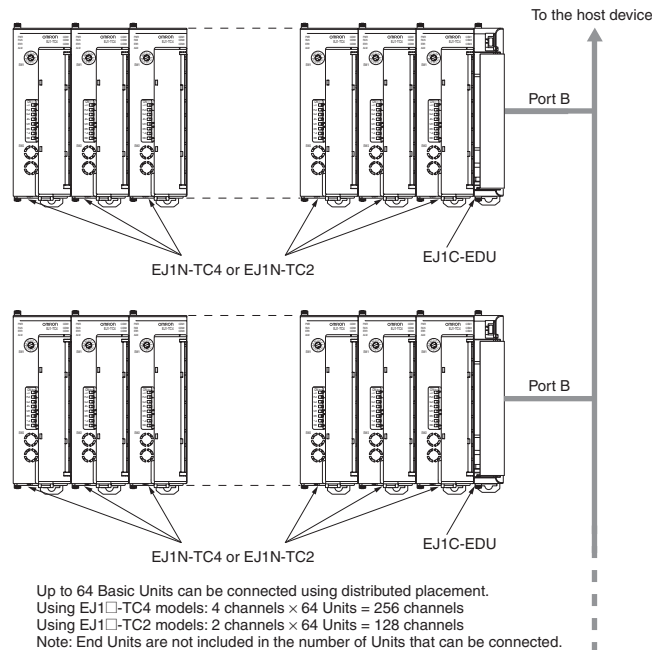

### Restrictions When Connecting with the G3ZA

- Up to 8 G3ZA Multi-channel Power Controllers can be connected to one Basic Unit (EJ1N-TC4/TC2).

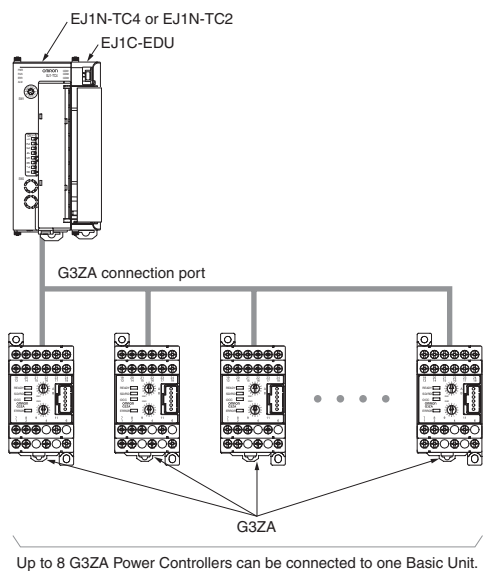

#### Wiring for Distributed Placement

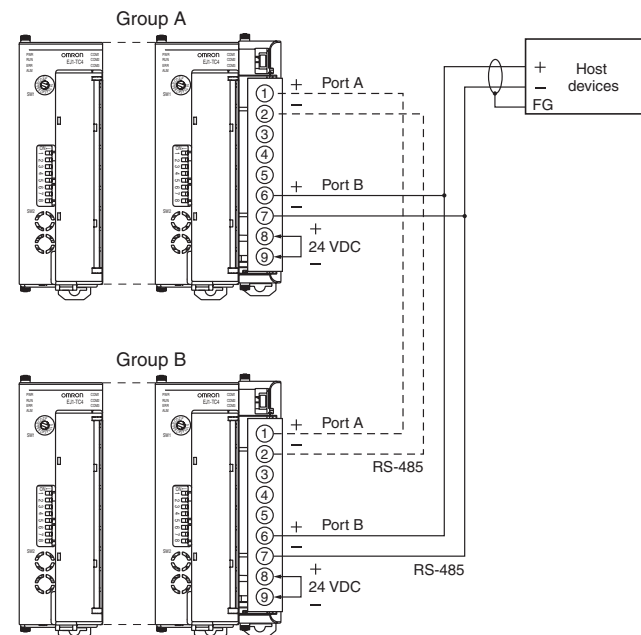

**Note:** Wire the dotted line when settings for all distributed Units are being made from one port A connector. If the dotted lines are not wired, make the settings for group A using the port A connector for group A and make the settings for group B using the port A connector for group B.

## Restrictions on Unit Placement

Always connect the HFU on the left side of the Basic Unit.

Do not connect the End Unit directly to the HFU.  
Always connect a Basic Unit to the End Unit.

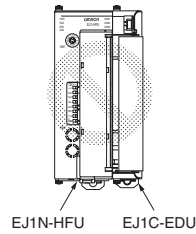
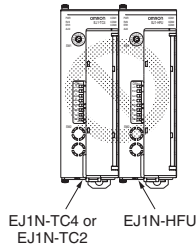

## Insulation Blocks

Each EJ1 Unit is electrically insulated for each function block as shown in the following figures.

Functional insulation is applied between the power supply, input, output, and communications terminal sections.

If reinforced double insulation is required, use power supplies that comply with IEC60664 for reinforced double insulation for the EJ1's external power supply and for power supplies connected to the EJ1.

### EJ1N-TC2

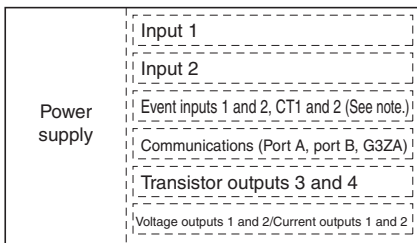

Functional isolation

### EJ1N-TC4

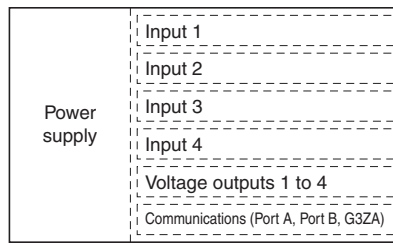

Functional isolation

### EJ1N-HFU □-NFL □

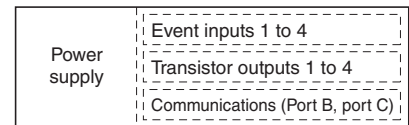

Functional isolation

### EJ1C-EDU

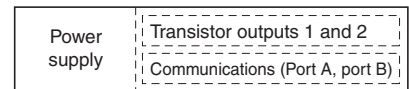

Functional isolation

**Note:** Not provided on models with current outputs.

## Programless Communications

Communications with PLCs from OMRON (SYSMAC CS/CJ/CP Series) and Mitsubishi Electric (MELSEC-Q/QnA/QnAS/An/Ans/FX<sub>3UC</sub> Series) can be performed without creating ladder programming.

Using programless communications enables monitoring and changing settings for the EJ1 by simply reading and writing to PLC memory.

The EJ1 automatically performs communications with the PLC, which reduces work hours spent programming for communications from the PLC to the EJ1.

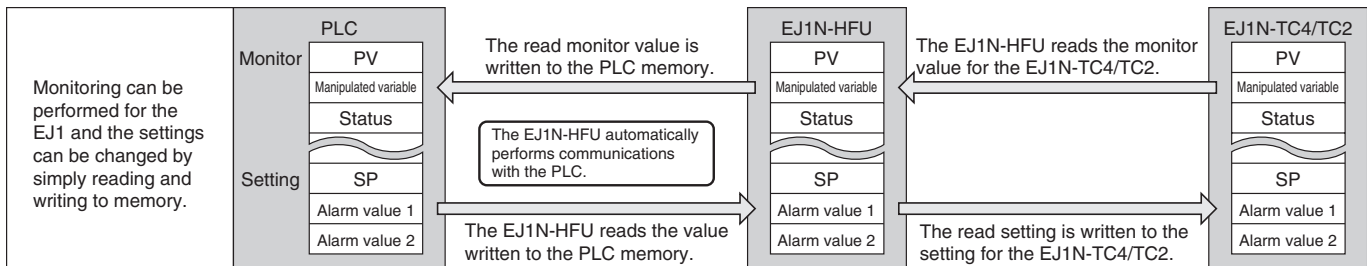

## Connectable Devices

### Connecting an EJ1 Controller 1:1 to a PLC SYSMAC CS/CJ/CP Series

Name	Model No.	Communications ports	
		Port 1	Port 2
Serial Communications Units	CJ1W-SCU21-V1	RS-232C	RS-232C
	CJ1W-SCU31-V1	RS-422A/485	RS-422A/485
	CJ1W-SCU41-V1	RS-422A/485	RS-232C
	CS1W-SCU21-V1 (See note.)	RS-232C	RS-232C
	CS1W-SCU31-V1	RS-422A/485	RS-422A/485
Serial Communications Boards	CS1W-SCB21-V1 (See note.)	RS-232C	RS-232C
	CS1W-SCB41-V1 (See note.)	RS-232C	RS-422A/485
CPU Units	CJ Series	---	RS-232C
	CS Series	---	RS-232C
	CP Series	RS-232C or RS-422A/485 can be used by adding an Option Board.	

**Note:** Use only products manufactured on or after December 20, 1999.

For details, refer to the *CS/CJ Series, Serial Communications Boards/Units Operation Manual* (Cat. No. W336).

**MELSEC-Q/QnA/QnAS Series**

Name	Model No.	Communications ports	
		Channel 1	Channel 2
Q-compatible Serial Communications Unit	QJ71C24N QJ71C24	RS-232C	RS-422/485
	QJ71C24N-R2 QJ71C24-R2	RS-232C	RS-232C
	QJ71C24N-R4	RS-422/485	RS-422/485
QnA-compatible Serial Communications Unit	AJ71QC24N	RS-232C	RS-422/485
	AJ71QC24N-R2	RS-232C	RS-232C
	AJ71QC24N-R4	RS-422	RS-422/485
QnAS-compatible Serial Communications Unit	A1SJ71QC24N	RS-232C	RS-422/485
	A1SJ71QC24N-R2	RS-232C	RS-232C

- Note:**
1. Refer to the Mitsubishi Electric PLC documentation for information on MELSEC PLCs.
  2. Direct connections to the EJ1 are possible only with RS-232C or RS-422.
  3. More than one EJ1 Controller to one PLC is not possible even with RS-422 communications. Refer to *Connecting EJ1 Controllers 1:N to a PLC*, below, for product combinations that support 1:N connections.
  4. Connection ability has been verified for the above MELSEC models. Design changes and other factors, however, may prevent normal connection. Always confirm operation in advance.

**MELSEC-An/AnS Series V1.1**

Name	Model No.	Communications ports
An-compatible Computer Link Unit	AJ71UC24	RS-232C or RS-422/485
AnS-compatible Computer Link Unit	A1SJ71UC24-R2	RS-232C
	A1SJ71UC24-R4	RS-422/485
	A1SJ71UC24-PRF	RS-232C

**Note:** Use a MELSEC-AnA/AnU CPU.

**MELSEC-FX<sub>3UC</sub> Series V1.1**

Name	Model No.	Communications ports
Communications Adapter	FX <sub>3U</sub> -232ADP	RS-232C
	FX <sub>3U</sub> -485ADP	RS-485
Function Board	FX <sub>3U</sub> -232-BD	RS-232C
	FX <sub>3U</sub> -485-BD	RS-485

**Connecting EJ1 Controllers 1:N to a PLC V1.1**

The combinations of PLCs and HFUs that can be connected 1:N are listed below.

**SYSMAC CS/CJ/CP Series**

Name	Model No.	Communications ports
Serial Communications Units	CJ1W-SCU31-V1	Port 1 or 2
	CJ1W-SCU41-V1	Port 1
	CS1W-SCU31-V1	Port 1 or 2
Serial Communications Board	CS1W-SCB41-V1 (See note.)	Port 2
CPU Units	CP Series	RS-422A/485 can be used by adding an Option Board.
EJ1N-HFU	EJ1N-HFUA-NFLK EJ1N-HFUB-NFLK	Port C

**Note:** Use only products manufactured on or after December 20, 1999.  
For details, refer to the *CS/CJ Series, Serial Communications Boards/Units Operation Manual* (Cat. No. W336).

**MELSEC-Q/QnA/QnAS Series**

Name	Model No.
Serial Communications Units	Channel 2 of QJ71C24N QJ71C24N-R4 Channel 2 of A1SJ71QC24N Channel 2 of AJ71QC24N AJ71QC24N-R4
EJ1N-HFU	EJ1N-HFUA-NFL2 EJ1N-HFUB-NFL2

**Note:** Refer to the Mitsubishi Electric PLC documentation for information on MELSEC PLCs.

# Connection

## External Connection

- Functional insulation is applied between the power supply and the I/O sections. If reinforced insulation is required, connect the input and output terminals to devices without any exposed current-carrying parts or to devices with reinforced insulation suitable for the maximum operating voltage of the power supply and I/O sections.
- To comply with the standards for noise terminal voltage for class A in EN 61326, install a noise filter (Densei Lamda MXB-1206-33 or the equivalent) to the DC power line as close as possible to the Temperature Controller.
- Use an SELV power supply that provides overcurrent protection. An SELV circuit is one separated from the power supply with double insulation or reinforced insulation, that does exceed an output voltage of 30 V r.m.s. and 42.4 V peak or 60 VDC max. The OMRON S8VM or S8VS Series is recommended for the power supply.

### EJ1N-TC4

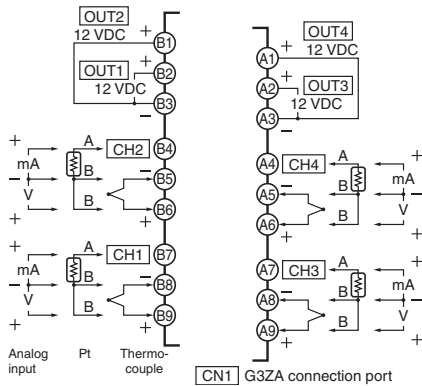

### EJ1N-TC2

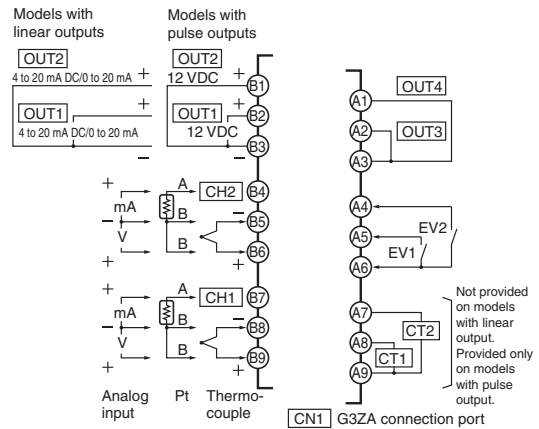

### EJ1N-HFU□-NFL□

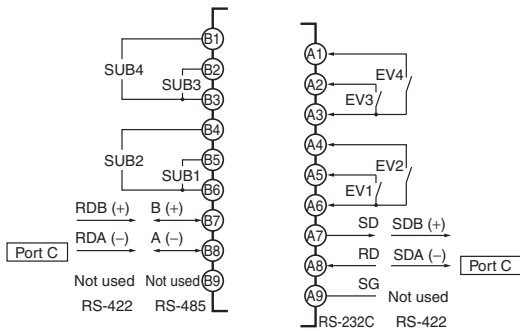

RS-485 for port C and RS-232C can be switched.  
A separate EJ1 model must be used for RS-422 communications.

### EJ1N-HFUB-DRT

DeviceNet Connector

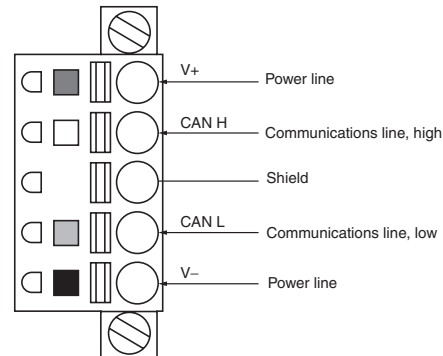

### EJ1C-EDUA

Model with Screw Terminals

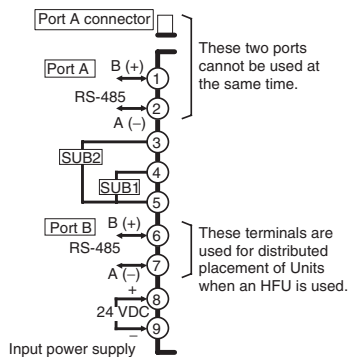

### EJ1C-EDUC

Model with Connector Terminal Block

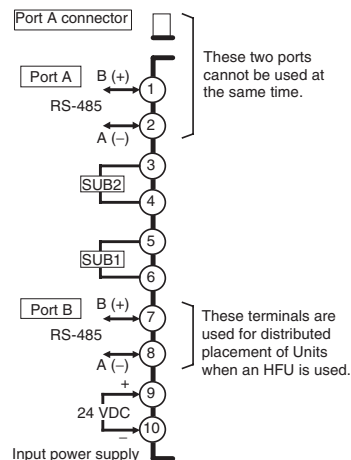

- Note:**
1. To connect to the G3ZA, separately purchase a G3ZA Connecting Cable (EJ1C-CBLA050) and connect it to the G3ZA connection port (CN1) on the EJ1.
  2. To connect to a computer using the port A connector, use a separately sold E58-C1FQ1 USB-Serial Conversion Cable. The Temperature Controller can be connected to a computer using USB.
  3. Models with screw-less clamp terminals have terminals A10 and B10, but they are not used. Do not connect anything to them.

# Nomenclature and Specification Settings

## Part Names

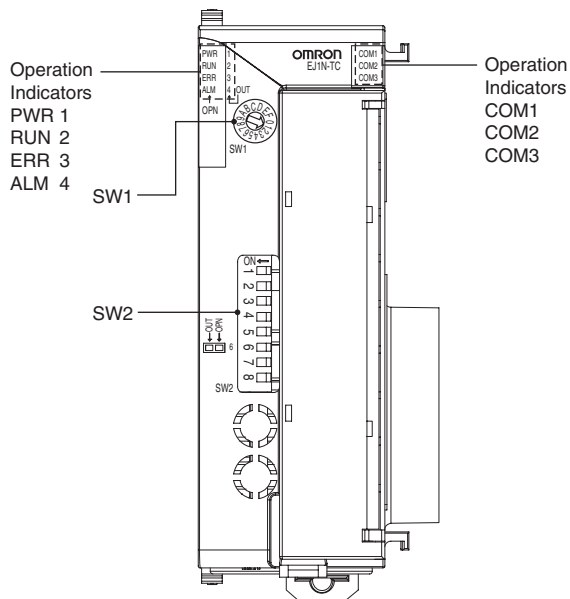

## Operation Indicators

### EJ1N-TC2/TC4

Operation Indicators	Meaning: When SW2 No. 6 is OFF	Meaning: When SW2 No. 6 is ON <sup>V1.2</sup>
<b>PWR/1 (green)</b> <sup>V1.2</sup>	Lights when the power is ON.	Lit when output 1 is ON.
<b>RUN/2 (green)</b> <sup>V1.2</sup>	Lights during operation.	Lit when output 2 is ON.
<b>ERR/3 (red)</b> <sup>V1.2</sup>	Flashes or lights when an error occurs.	Lit when output 3 is ON.
<b>ALM/4 (red)</b> <sup>V1.2</sup>	Lights when an alarm is activated.	Lit when output 4 is ON.
<b>COM 1 (orange)</b>	Flashes during communications via port A on the End Unit.	
<b>COM 2 (orange)</b>	Flashes during communications via port B on the End Unit.	
<b>COM 3 (orange)</b>	Flashes during communications with the G3ZA.	

### EJ1N-HFU□-NFL□

Operation Indicators	Meaning
<b>PWR (green)</b>	Lit while the power is ON. (See note.)
<b>RUN (green)</b>	---
<b>ERR (red)</b>	Flashes or lights when an error occurs.
<b>ALM (red)</b>	Lights when an alarm is activated.
<b>COM 1 (orange)</b>	Flashes during communications via port A on the End Unit.
<b>COM 2 (orange)</b>	Flashes when the EJ1 system is in operation.
<b>COM 3 (orange)</b>	Flashes during communications via port C.

**Note:** Some time is required for the indicators to light after the power is turned ON.

## ■ Specification Settings

### Switch Operation

- Check that the EJ1 is turned OFF before operating any switch other than pin 6 of SW2. Settings are read only when power is turned ON.
- Set the switches with a small flat-blade screwdriver. Do not set the switches midway between settings.
- SW1 is set to 1 and SW2 pins are all set to OFF in the default settings.

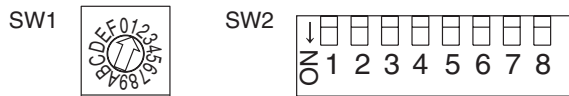

### Setting the Unit Number

SW1 and SW2 are used together to set the unit number to between 00 and 63. The factory setting is unit number 01.

SW2		SW1															
1	2	0	1	2	3	4	5	6	7	8	9	A	B	C	D	E	F
OFF	OFF	00	01	02	03	04	05	06	07	08	09	10	11	12	13	14	15
ON	OFF	16	17	18	19	20	21	22	23	24	25	26	27	28	29	30	31
OFF	ON	32	33	34	35	36	37	38	39	40	41	42	43	44	45	46	47
ON	ON	48	49	50	51	52	53	54	55	56	57	58	59	60	61	62	63

### SW2 Settings

#### EJ1N-TC2/TC4

SW2	Meaning
3 <b>V1.2</b>	Set to ON when using the Modbus communications protocol for port B. OFF: The setting for port B communications protocol is used. ON: Modbus is used.
4 to 5 <b>V1.2</b>	Set the baud rate of port B. 4 = OFF, 5 = OFF: Use the baud rate parameter setting for port B (default: 9.6 kbps). 4 = ON, 5 = OFF: 19.2 kbps 4 = OFF, 5 = ON: 38.4 kbps 4 = ON, 5 = ON: 115.2 kbps
6 <b>V1.2</b>	Set to ON to display the output status on the operation indicators. OFF: The operation status is displayed (PWR, RUN, ERR, and ALM). ON: The output status is displayed (outputs 1, 2, 3, and 4). <b>Note:</b> Normally keep this pin set to OFF so that the operation status can be checked.
7	ON: G3ZA Multi-channel Power Controller in operation ON when using a G3PW Power Controller. <b>V1.1</b>
8	Use when an HFU is used and Units are distributed. (Refer to the User's Manual for details.)

**Note:** Make sure power to the Unit is turned OFF before making settings for any pin other than pin 6.  
Pin 6 can be turned ON or OFF while the power is ON.

#### EJ1N-HFU□-NFL□

SW2	Meaning
3 to 7	Not used (OFF)
8	<ul style="list-style-type: none"> <li>• EJ1N-HFU□-NFLK OFF: RS-485 is selected. ON: RS-232C is selected.</li> <li>• EJ1N-HFU□-NFL2 OFF (Not used.)</li> </ul>

## Part Names (EJ1N-HFUB-DRT)

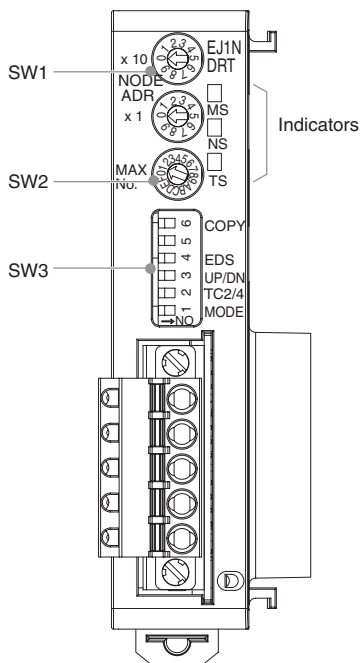

## Operation Indicators

### EJ1N-HFUB-DRT

Operation Indicators		Meaning
MS Module status	Green	ON: The Unit condition is normal. Flashing: The connection configuration has not been set.
	Red	ON: Fatal error Flashing: Non-fatal error
NS Network status	Green	ON: Communications established Flashing: Communications not established
	Red	ON: Fatal communications error Flashing: Non-fatal communications error
TS Temperature Controller communications status	Green	ON: Communicating with the Temperature Controllers Flashing: The copy operation is being performed.
	Red	Flashing: Communications error with a Temperature Controller Flashing: The copy operation failed.

## Specification Settings

### Switch Operation

- Always turn OFF the DeviceNet communications power supply and EDU power supply before setting the Unit. (See note.)
- Set the switches with a small flat-blade screwdriver. Do not set the switches midway between settings.
- The SW1 switches are set to 00, SW2 is set to 0, and SW3 pins are all set to OFF in the default settings.

**Note:** The setting of pin 3 on SW3 can be changed while the power is ON.

### SW1 Settings

Use these switches to set the node address as a slave in the DeviceNet network between 00 and 63 decimal (node addresses 64 to 99 cannot be used).

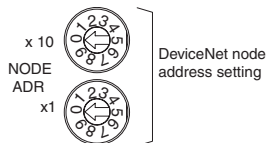

### SW2 Settings

Use this switch to set the highest communications unit number (0 to F: 0 to 15 decimal) of the connected Temperature Controllers. This setting is enabled only when DIP switch pin 1 is set to ON (simple I/O allocations).



### SW3 Settings

DIP switch	Meaning
6 (COPY) ---	Upload/Download OFF → ON (1 s min., 5 s max.) → OFF
5 ---	Not used.
4 (EDS) OFF	Use the OMRON Configurator.
	ON
3 (UP/DN) OFF	Upload (from Temperature Controller to DeviceNet Communications Unit)
	ON
2 (TC2/4) OFF	Simple allocation to TC2 Units.
	ON
1 (MODE) OFF	I/O Allocation from the Configurator.
	ON

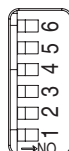

# Functional Upgrades **V1.1** **V1.2**

Functions depend on the version that you are using. The functional upgrades are given below. Refer to the User's Manual (Cat. No. H142) for details.

Applicable Unit	Version	V1.1	V1.2
Basic Units (EJ1N-TC2/TC4)		<ul style="list-style-type: none"> <li>Modbus communications can be used on port B.</li> <li>Software version 2 of the G3ZA Multi-channel Power Controller can be used.</li> </ul> <p><b>Note: 1.</b> When more than one G3ZA Multi-channel Power Controller is connected, version 1 and version 2 can be mixed. (Up to 8 G3ZA Multi-channel Power Controllers can be connected.)</p> <p><b>2.</b> Software version 2 of G3ZA Multi-channel Power Controller can also be used with EJ1 version1.0.</p>	<ul style="list-style-type: none"> <li>Autotuning is provided for heating/cooling control.</li> <li>Self-tuning has been added.</li> <li>A switch can be used to display the output status on the operation indicators during operation.</li> <li>Modbus communications can be used to read and write all parameters, and to execute any of the operation commands.</li> <li>A switch setting can be changed to use Modbus communications on port B.</li> <li>A switch setting can be used to set the baud rate of port B.</li> <li>A C0/80 status has been added to the variable types.</li> <li>Up to eight G3PW Power Controllers can be connected to one Basic Unit.</li> </ul> <p><b>Note: 1.</b> The G3PW can be connected to EJ1 V1.1. <b>2.</b> The G3PW and G3ZA cannot be used together.</p>
Advanced Unit (EJ1N-HFU□-NFL□)		<ul style="list-style-type: none"> <li>Programless communications can be used with 1: N connections.</li> <li>The maximum number of parameters that can be specified for programless upload/download settings has been increased from 300 to 600 each.</li> <li>Connection is now possible to MELSEC-QnA/An/AnS/FX3uc-series PLCs.</li> <li>A new setting read operation has been added to programless communications: Setting Read 2.</li> <li>The speed of programless communications has been increased.</li> <li>Either "continue" or "stop" can be selected for when errors occur in programless communications.</li> </ul>	<ul style="list-style-type: none"> <li>Bit specification operation commands have been added to the parameters that can be specified for programless download settings. This simplifies the program when operation commands are executed.</li> <li>The G3ZA or G3PW Monitor parameter has been added to the parameters that can be specified for programless upload settings. Up to four G3ZA Multi-channel Power Controllers or up to four G3PW Power Controllers can be connected to one Basic Unit.</li> <li>The maximum number of parameters that can be specified for programless upload/download setting has been increased from 600 to 1200 each.</li> <li>The maximum number of Basic Units that an HFU with Programless Communications can control has been increased from 16 to 32 Units.</li> <li>Communications unit numbers 32 to 39 can be used in the HFU via programless communications. This allows the communications unit numbers of Basic Units connected to an HFU to be numbered sequentially, making it easy to copy HFU and Basic Unit settings to other HFUs and Basic Units.</li> </ul>
Support Software		CX-Thermo version 3.20 or higher	CX-Thermo version 4.1 or higher

## Identifying Upgraded Models

The new functionality can be used with version 1.2 (V1.2). Check the label on the Temperature Controller or the box to determine the version. Models not marked "Ver. 1.1" are version 1.0.

Box Label

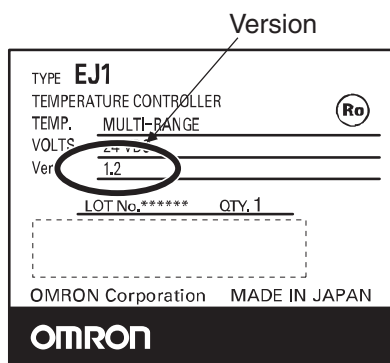

Temperature Controller Label

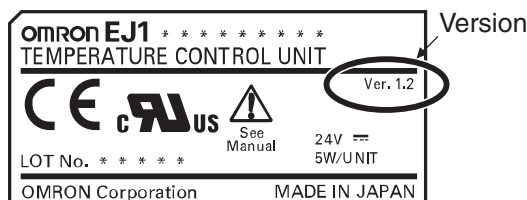

**Note:** The above example is for version 1.2.

# Dimensions

Note: All units are in millimeters unless otherwise indicated.

## Temperature Controller

### Basic Units

EJ1N-TC

### HFUs

EJ1N-HFU□-NFL□

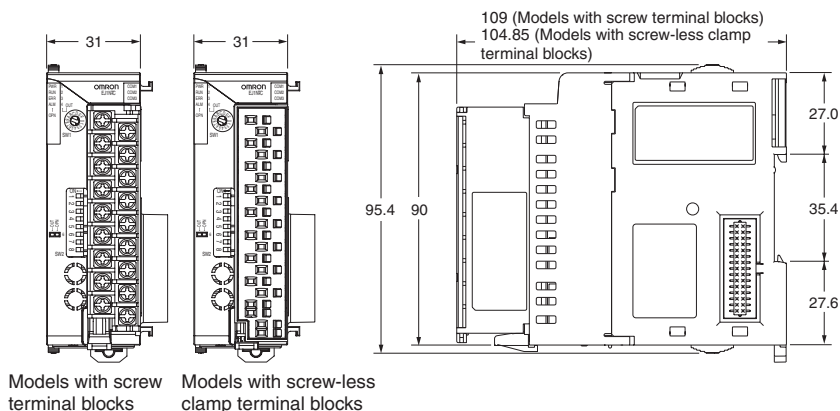

Models with screw terminal blocks    Models with screw-less clamp terminal blocks

### HFUs

EJ1N-HFUB-DRT

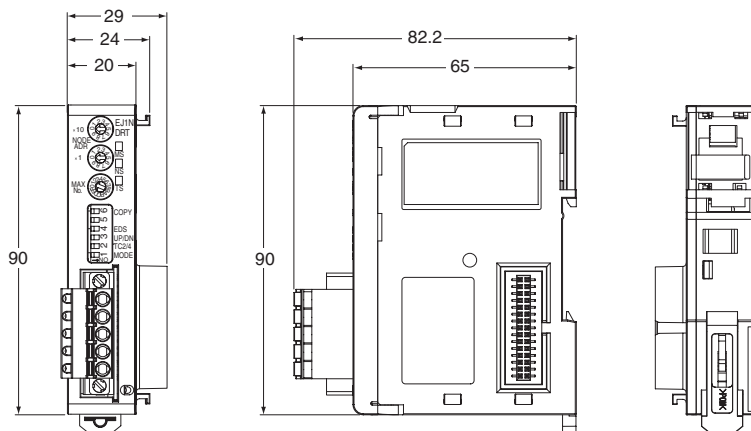

### End Units

EJ1C-EDU

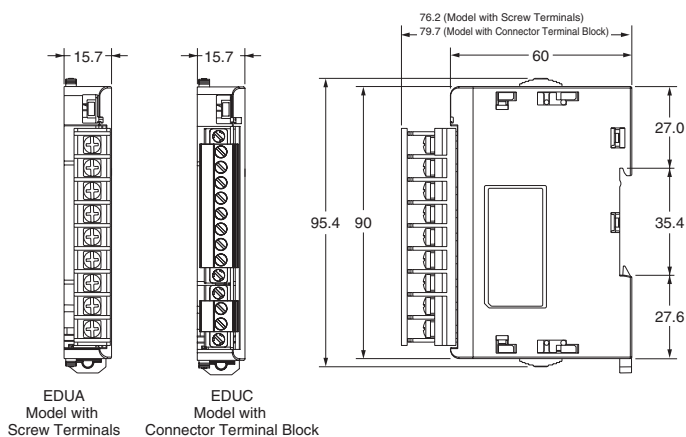

EDUA Model with Screw Terminals    EDUC Model with Connector Terminal Block

## Options

### Current Transformer (Sold Separately)

#### E54-CT1

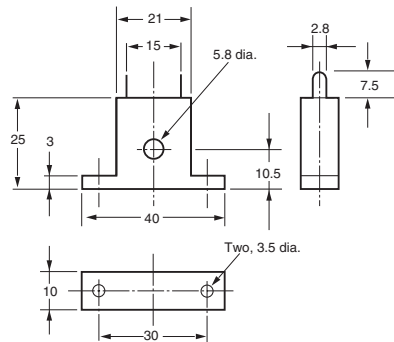
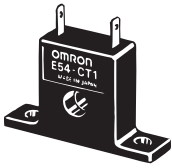

#### E54-CT3

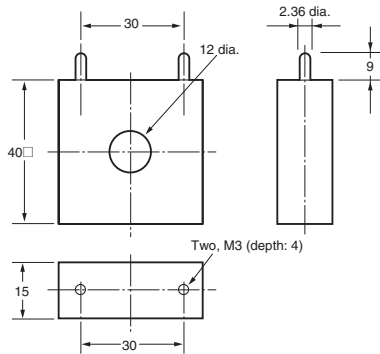

#### E54-CT3 Accessory

##### • Armature

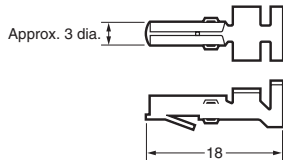

##### • Plug

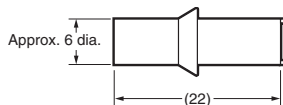

#### Connection Example

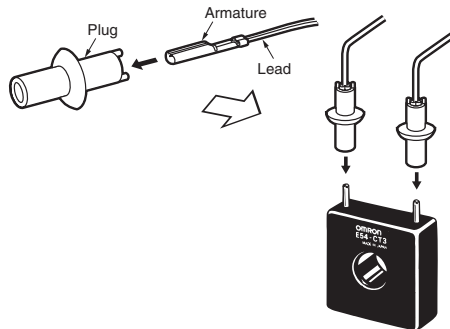

### Rail Mounting Equipment (Order Separately)

#### DIN Rail

##### PFP-100N

##### PFP-50N

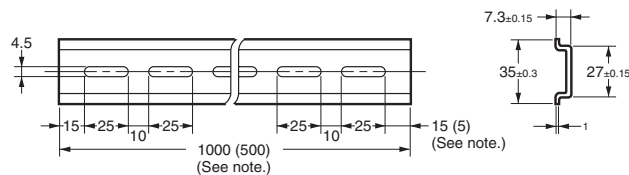
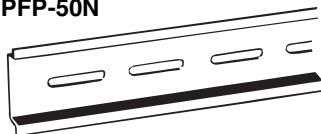

**Note:** The figures in parentheses are dimensions for the PFP-50N.

### End Plate

#### PFP-M

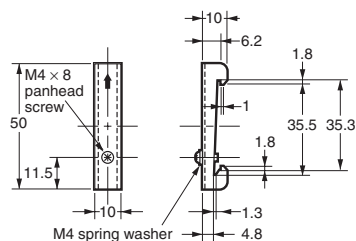
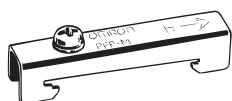

**Note:** Two screws are included with the EJ1C-EDU for the End Plate. Always attach End Plates to both sides.

# Safety Precautions

## ⚠ CAUTION

Do not touch the terminals while power is being supplied. Doing so may occasionally result in minor injury due to electric shock.



Use a power supply that complies with the reinforced insulation specified in IEC 60664 for the EJ1 external power supply or the power supply connected to the EJ1. If non-compliant power supplies are used, electric shock may occasionally result in minor injury.



Do not allow pieces of metal, wire clippings, or fine metallic shavings or filings from installation to enter the product. Doing so may occasionally result in electric shock, fire, or malfunction.



Do not use the product where subject to flammable or explosive gas. Otherwise, minor injury from explosion may occasionally occur.



Never disassemble, modify, or repair the product or touch any of the internal parts. Minor electric shock, fire, or malfunction may occasionally occur.



Tighten the terminal screws to between 0.40 and 0.56 N·m. Loose screws may occasionally result in fire.



Set the parameters of the product so that they are suitable for the system being controlled. If they are not suitable, unexpected operation may occasionally result in property damage or accidents.



A malfunction in the product may occasionally make control operations impossible or prevent alarm outputs, resulting in property damage. To maintain safety in the event of malfunction of the product, take appropriate safety measures, such as installing a monitoring device on a separate line.



## ■ Precautions for Safe Use

Observe the following points to ensure safe operation.

- The product is designed for indoor use only. Do not use the product outdoors or in any of the following locations.
  - Places directly subject to heat radiated from heating equipment
  - Places subject to splashing liquid or oil atmosphere
  - Places subject to direct sunlight
  - Places subject to dust or corrosive gas (in particular, sulfide gas or ammonia gas)
  - Places subject to intense temperature change
  - Places subject to icing or condensation
  - Places subject to vibration or strong shocks
- Use and store the product within the rated temperature and humidity ranges. Provide forced-cooling if required.
- To allow heat to escape, do not block the area around the product. Do not block the ventilation holes on the product.
- Be sure to wire properly with correct polarity of terminals.
- Use specified size (M3, width 5.8 mm or less) crimped terminals for wiring. To connect bare wires to the terminal block, use copper braided or solid wires with a gage of AWG22 to AWG14 (equal to cross-sectional area of 0.326 to 2.081 mm<sup>2</sup>) for power supply lines and a gage of AWG28 to AWG16 (equal to cross-sectional area of 0.081 to 1.309 mm<sup>2</sup>). (The stripping length is 6 to 8 mm.)
- Do not wire terminals that do not have an identified use.

- Allow as much space as possible between the product and devices that generate a powerful high-frequency or surge. Separate the high-voltage or large-current power lines from other lines, and avoid parallel or common wiring with the power lines when you are wiring to the terminals.
- Use the product within the rated load and power supply.
- Make sure that the rated voltage is attained within two seconds of turning ON the power.
- It takes 30 minutes from the time the Temperature Controller is turned ON until the current temperature is displayed. Always turns ON the power supply at least 30 minutes before starting temperature control.
- The switch or circuit breaker must be within easy reach of the operator, and must be marked as a disconnecting means for this unit.
- Do not use paint thinner or similar chemical to clean with. Use standard grade alcohol.
- Design the system (e.g., the control panel) allowing leeway for the delay required before product outputs are valid after turning ON power to the product.
- Never touch the electronic components, connectors, or patterns on product boards with your bare hands. Always hold the product by the case. Inappropriately handling the product may occasionally damage internal components due to static electricity.
- Use a switch, relay, or other device with contacts to turn OFF the power supply quickly. Gradually lowering the voltage of the power supply may result in incorrect outputs or memory errors.
- Do not touch the electronic components with your hands or subject them to shock when removing the terminal block.
- Connect only the specified number of products in only a specified configuration.
- Mount the product to a DIN Rail mounted vertically to the ground.
- Always turn OFF the power supply before wiring the product, replacing the product, or changing the product configuration.
- Attach the enclosed cover seal to the connector opening on the left end product during installation.
- Do not use port B on the end product when using port C on HFUs.
- Install the product only after reading the manual provided with the End Unit.

## ■ Precautions for Correct Use

### Installation

1. Do not connect the End Unit directly to an HFU.
2. Connect the End Unit to the right side of a Basic Unit.
3. Connect the HFU to the left side of the Basic Units.
4. Connection is not possible to CJ1-series PLCs.
5. Use the EJ1G-□□ for gradient temperature control. When not using gradient temperature control, use the EJ1N-□□.
6. When removing the terminal block to replace a Unit, be sure that the new Unit is the same as the Unit that is being replaced.

### Service Life

1. Use the product within the following temperature and humidity ranges:

Temperature:  $-10^{\circ}\text{C}$  to  $55^{\circ}\text{C}$  (with no condensation or icing)

Humidity: 25% to 85%

When the Temperature Controller is incorporated in a control panel, make sure that the controller's ambient temperature and not the panel's ambient temperature does not exceed  $55^{\circ}\text{C}$ .

2. The service life of electronic devices like Temperature Controllers is determined not only by the number of times the relay is switched but also by the service life of internal electronic components. Component service life is affected by the ambient temperature: the higher the temperature, the shorter the service life and the lower the temperature, the longer the service life. Therefore, the service life can be extended by lowering the temperature of the Temperature Controller.
3. Mounting two or more Temperature Controllers side by side, or mounting Temperature Controllers above each other may cause heat to build up inside the Temperature Controllers, which will shorten their service life. If the Temperature Controllers are mounted above each other or side by side, use forced cooling by fans or other means of air ventilation to cool down the Temperature Controllers. However, be sure not to cool only the terminals. Doing so will result in measurement errors.

### Ensuring Measurement Accuracy

1. When extending or connecting the thermocouple lead wire, be sure to use compensating wires that match the thermocouple types.
2. When extending or connecting the lead wire of the platinum resistance thermometer, be sure to use wires that have low resistance and keep the resistance of the three lead wires the same.
3. Mount the Temperature Controller so that it is horizontally level.
4. If the measurement accuracy is low, check to see if input shift has been set correctly.

### Precautions for Operation

1. A certain amount of time is required for the outputs to turn ON from the time the power supply is turned ON. Due consideration must be given to this time when incorporating Temperature Controllers in a sequence circuit.
2. It takes 30 minutes from the time the Temperature Controller is turned ON until the current temperature is displayed. Always turns ON the power supply at least 30 minutes before starting temperature control.
3. Avoid using the Temperature Controller near a radio, television set, or other wireless device. Its use would result in reception disturbance.

### Wiring Screw-Less Clamp Terminals

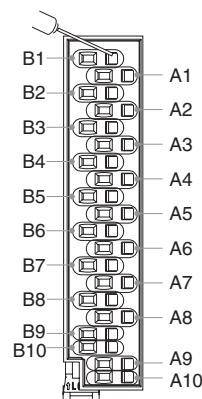

There are two holes for each terminal. The hole on the right is the operation hole and the hole on the left is the wire hole.

Insert a flat-blade screwdriver with a width of 2.5 mm into the operation hole, insert the wire into the wire hole, and then remove the screwdriver. The wire will be clamped.

Use crimp terminals that are suitable for the cross-sectional area of the wire.

Recommended crimp terminals:  
Weidmuller H-sleeve series

### Installation

#### Connecting Units

1. Align the connectors and connect the Units to each other. Connect an End Unit to the Unit on the right end.

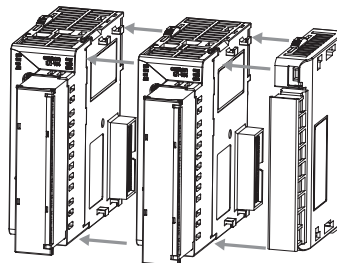

- Note:**
1. Do not connect the End Unit directly to an HFU.
  2. Connect the End Unit to the right side of a Basic Unit.
2. Slide the yellow sliders on the top and bottom of the Units until they click into place.

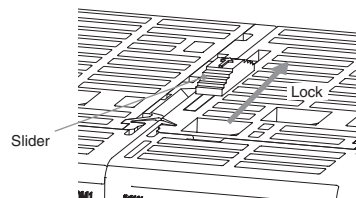

3. Attach the cover seal to the connector opening on the Unit on the left end of the EJ1.

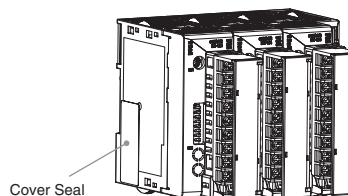

## Removing the Terminal Block

1. Press down the terminal block lever.

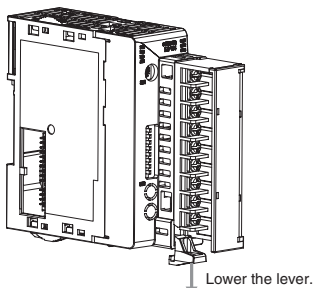

2. Pull out the terminal block.

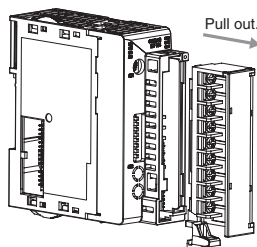

## Mounting to the DIN Rail

### Mounting

Catch the hook located on the top of the Unit onto the DIN Rail and press the Unit until the Unit locks into place.

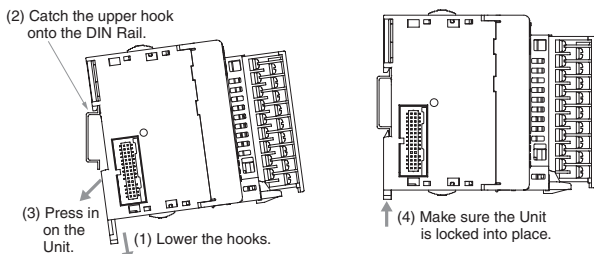

### Dismounting

Pull down on the hook with a flat-blade screwdriver and lift up on the Unit.

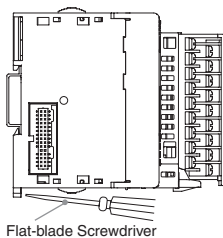

Mount one End Plate to each side of the EJ1C-EDU (PFP-M End Plates are included with the End Unit).

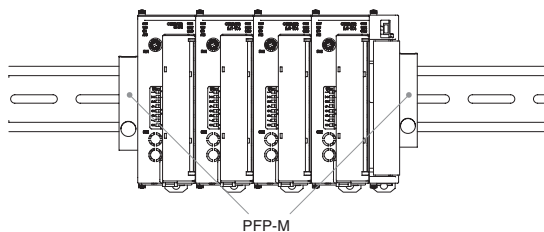

Install the DIN Rail vertically to the ground.

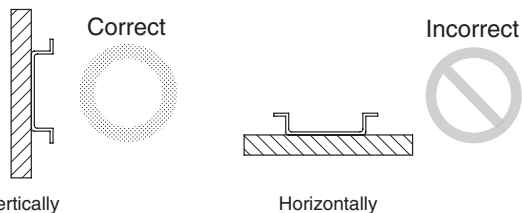

Applicable DIN Rail (sold separately): PFP-100N (100 cm), PFP-50N (50 cm)

## Connecting to the G3ZA (EJ1N-TC)

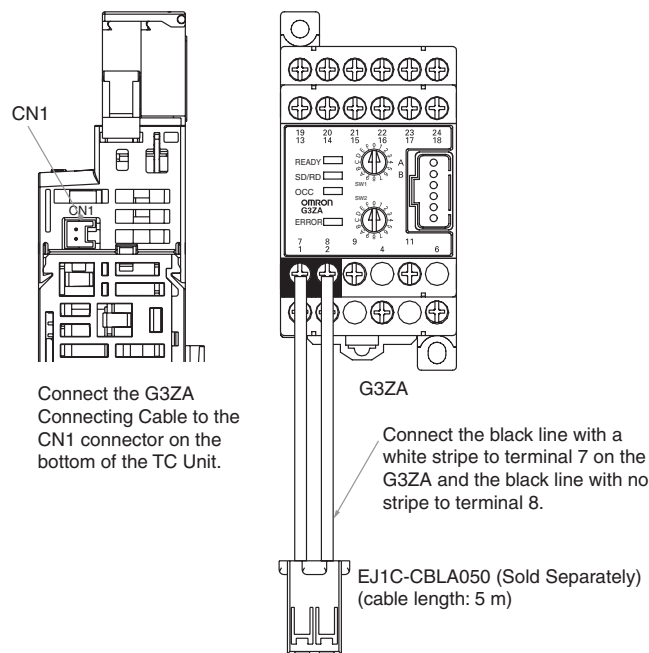

Refer to the "G3ZA Instruction Manual" for wiring methods.

## Connecting to the G3PW (EJ1N-TC)

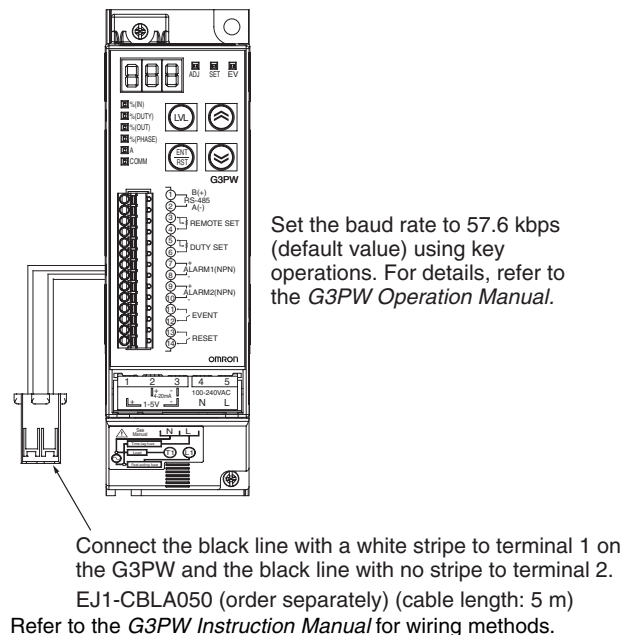

Refer to the following manual for precautionary information and other information necessary to use the EJ1:  
**EJ1 Modular Temperature Controller User's Manual (Cat. No. H142)**

# I/O Devices

## Examples of EJ1-series Temperature Controllers/Output Devices

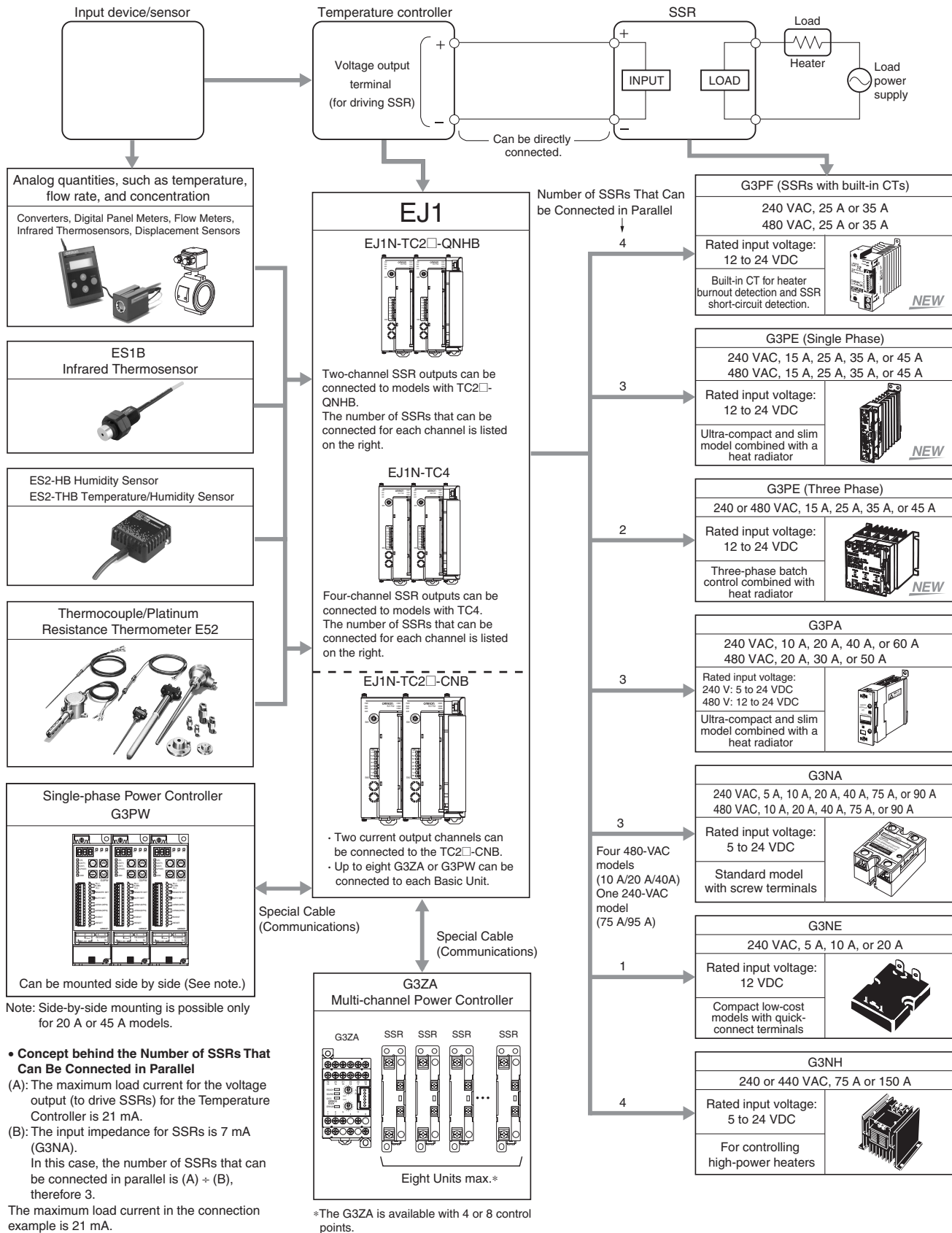

# CX-Thermo Support Software Ver. 4.1 EST2-2C-MV4

## Monitoring/Setting Support Software for E5CN/CN-H, E5AN/AN-H, E5EN/EN-H, E5ZN, E5□R/□R-T, and EJ1 Temperature Controllers Enabling Faster Parameter Setup, Device Adjustment, and Maintenance



- Enables editing and batch-downloading parameters from a personal computer, reducing the work required to set parameters. Usability is improved with table-formatted parameter editing from version. 4.0.
- Supports Trend Monitoring: Monitor data (PV, SP, MV, PID parameter, Alarm ON/OFF, etc.) for up to 31 E5□N/□N-H Temperature Controllers. Connect up to 64 EJ1N, 17 EJ1G, or 16 E5ZN Temperature Controllers. (The Temperature Controllers must be from the same series.)
- Supports parameter masks to hide parameters unnecessary to display. (Supported only by the E5□N/□N-H and E5□R/□R-T).
- Logic operations enable setting inputs from external inputs (event inputs) or temperature status, outputs to external outputs (control or auxiliary outputs), and changing operating status with ON/OFF delays. (Supported only by the E5□N/□N-H).
- Easy adjustment of control performance by fine-tuning.
  - \* Fine-tuning instructs the CX-Thermo to calculate a PID parameters by directly inputting commands to improve response.

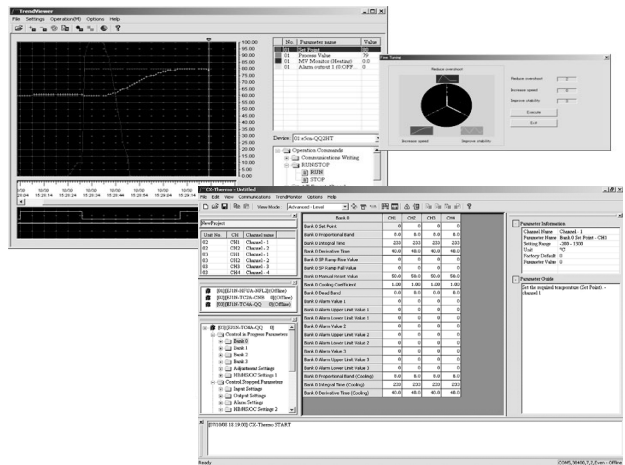

**NEW**

## Ordering Information

### List of Models

Name	Model
CX-Thermo Support Software	EST2-2C-MV4

## Specifications

<b>Compatible devices</b>	<b>Temperature Controllers</b>	E5CN (available from April 2004) E5AN, E5EN (available from February 2005), E5CN-H, E5AN-H, E5EN-H E5AR, E5ER E5AR-T, E5ER-T E5ZN EJ1N-TC4, EJ1N-TC2, EJ1N-HFU EJ1G-TC4, EJ1G-TC2, EJ1G-HFU G3ZA (only when connected to EJ1N-TC4, EJ1N-TC2, EJ1G-TC4, EJ1G-TC2) <b>Note:</b> Models with DeviceNet communications are not supported.
<b>Personal computer system requirements</b>	<b>OS</b>	Windows 2000 (service pack 3 or higher), XP, or Vista
	<b>CPU</b>	300 MHz min.
	<b>Memory</b>	128 MB min.
	<b>Harddisk</b>	300 MB min. available space
	<b>CD-ROM</b>	One CD-ROM drive min.
	<b>Monitor</b>	SVGA (800 × 600) min.
	<b>Communications ports</b>	<ul style="list-style-type: none"> <li>• RS-232C port, or USB port, 1 port min.</li> </ul>
<b>Connection method</b>		<ul style="list-style-type: none"> <li>• An E58-CIFQ1 USB-Serial Conversion Cable is required to connect a computer to the setup tool port the E5□N, E5□N-H, or EJ1.</li> <li>• A K3SC Interface Converter is used to connect a computer to models with RS-422/RS-485 communications.</li> <li>• An E58-CIFIR USB-Infrared Conversion Cable is required to wirelessly connect a computer to models with infrared communications (E5AN-H or E5EN-H).</li> </ul>

# USB-Serial Conversion Cable E58-CIFQ1

## Cable for Support Software Enables Connection Even with Temperature Controllers Not Equipped with Communications

- Easily set Temperature Controller parameters by connecting the computer's USB port and an EJ1, or a new-model E5CN, E5AN, or E5EN.



## Ordering Information

Model
E58-CIFQ1

**Note:** Older models of the E5CN, E5AN, and E5EN are not supported.

## Specifications

<b>Applicable OS</b>	Windows 2000/XP
<b>Applicable software</b>	Thermo Mini, CX-Thermo Ver. 3.0 or higher
<b>Applicable models</b>	EJ1, E5CN, E5AN, E5EN Series (new models)
<b>USB interface standard</b>	Conforms to USB Specification 1.1.
<b>DTE speed</b>	38,400 bps
<b>Connector specifications</b>	Computer: USB (type A plug) Temperature Controller: Serial
<b>Power supply</b>	Bus power (Supplied from USB host controller.)
<b>Power supply voltage</b>	5 VDC
<b>Current consumption</b>	70 mA
<b>Ambient temperature range</b>	Operating: 0°C to 55°C, Stored: -20°C to 60°C (with no icing or condensation)
<b>Ambient humidity range</b>	Operating: 10% to 80% (with no condensation)
<b>Weight</b>	Approx. 100 g

**Note:** A driver must be installed in the personal computer. Refer to installation information in the operation manual for the Conversion Cable.

## Dimensions

(Unit: mm)

### USB-Serial Conversion Cable

E58-CIFQ1

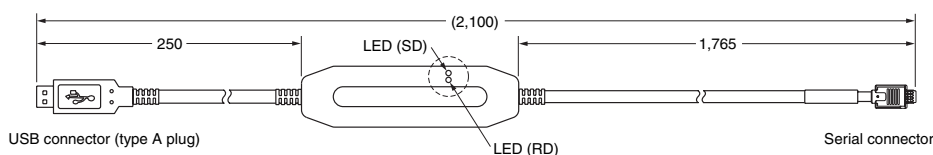
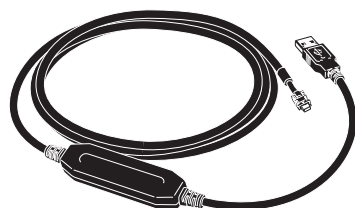

# Warranty and Application Considerations

## Read and Understand This Catalog

Please read and understand this catalog before purchasing the products. Please consult your OMRON representative if you have any questions or comments.

## Warranty and Limitations of Liability

### WARRANTY

OMRON's exclusive warranty is that the products are free from defects in materials and workmanship for a period of one year (or other period if specified) from date of sale by OMRON.

OMRON MAKES NO WARRANTY OR REPRESENTATION, EXPRESS OR IMPLIED, REGARDING NON-INFRINGEMENT, MERCHANTABILITY, OR FITNESS FOR PARTICULAR PURPOSE OF THE PRODUCTS. ANY BUYER OR USER ACKNOWLEDGES THAT THE BUYER OR USER ALONE HAS DETERMINED THAT THE PRODUCTS WILL SUITABLY MEET THE REQUIREMENTS OF THEIR INTENDED USE. OMRON DISCLAIMS ALL OTHER WARRANTIES, EXPRESS OR IMPLIED.

### LIMITATIONS OF LIABILITY

OMRON SHALL NOT BE RESPONSIBLE FOR SPECIAL, INDIRECT, OR CONSEQUENTIAL DAMAGES, LOSS OF PROFITS, OR COMMERCIAL LOSS IN ANY WAY CONNECTED WITH THE PRODUCTS, WHETHER SUCH CLAIM IS BASED ON CONTRACT, WARRANTY, NEGLIGENCE, OR STRICT LIABILITY.

In no event shall the responsibility of OMRON for any act exceed the individual price of the product on which liability is asserted.

IN NO EVENT SHALL OMRON BE RESPONSIBLE FOR WARRANTY, REPAIR, OR OTHER CLAIMS REGARDING THE PRODUCTS UNLESS OMRON'S ANALYSIS CONFIRMS THAT THE PRODUCTS WERE PROPERLY HANDLED, STORED, INSTALLED, AND MAINTAINED AND NOT SUBJECT TO CONTAMINATION, ABUSE, MISUSE, OR INAPPROPRIATE MODIFICATION OR REPAIR.

## Application Considerations

### SUITABILITY FOR USE

OMRON shall not be responsible for conformity with any standards, codes, or regulations that apply to the combination of products in the customer's application or use of the products.

Take all necessary steps to determine the suitability of the product for the systems, machines, and equipment with which it will be used.

Know and observe all prohibitions of use applicable to this product.

NEVER USE THE PRODUCTS FOR AN APPLICATION INVOLVING SERIOUS RISK TO LIFE OR PROPERTY WITHOUT ENSURING THAT THE SYSTEM AS A WHOLE HAS BEEN DESIGNED TO ADDRESS THE RISKS, AND THAT THE OMRON PRODUCTS ARE PROPERLY RATED AND INSTALLED FOR THE INTENDED USE WITHIN THE OVERALL EQUIPMENT OR SYSTEM.

## Disclaimers

### PERFORMANCE DATA

Performance data given in this catalog is provided as a guide for the user in determining suitability and does not constitute a warranty. It may represent the result of OMRON's test conditions, and the users must correlate it to actual application requirements. Actual performance is subject to the OMRON *Warranty and Limitations of Liability*.

### CHANGE IN SPECIFICATIONS

Product specifications and accessories may be changed at any time based on improvements and other reasons. Consult with your OMRON representative at any time to confirm actual specifications of purchased product.

### DIMENSIONS AND WEIGHTS

Dimensions and weights are nominal and are not to be used for manufacturing purposes, even when tolerances are shown.

### ALL DIMENSIONS SHOWN ARE IN MILLIMETERS.

To convert millimeters into inches, multiply by 0.03937. To convert grams into ounces, multiply by 0.03527.

#### OMRON Corporation

Industrial Automation Company

Control Devices Division H.Q.

Analog Controller Division

Shiokoji Horikawa, Shimogyo-ku,

Kyoto, 600-8530 Japan

Tel: (81) 75-344-7080/Fax: (81) 75-344-7149

2-2-1 Nishikusatsu, Kusatsu-shi,

Shiga, 525-0035 Japan

Tel: (81) 77-565-5216/Fax: (81) 77-565-5568

#### Regional Headquarters

OMRON EUROPE B.V.

Wegalaan 67-69-2132 JD Hoofddorp

The Netherlands

Tel: (31)2356-81-300/Fax: (31)2356-81-388

OMRON Industrial Automation Global: [www.ia.omron.com](http://www.ia.omron.com)

#### OMRON ELECTRONICS LLC

One Commerce Drive Schaumburg,

IL 60173-5302 U.S.A.

Tel: (1) 847-843-7900/Fax: (1) 847-843-7787

#### OMRON ASIA PACIFIC PTE. LTD.

No. 438A Alexandra Road # 05-05/08 (Lobby 2),

Alexandra Technopark, Singapore 119967

Tel: (65) 6835-3011/Fax: (65) 6835-2711

#### OMRON (CHINA) CO., LTD.

Room 2211, Bank of China Tower,

200 Yin Cheng Zhong Road,

PuDong New Area, Shanghai, 200120, China

Tel: (86) 21-5037-2222/Fax: (86) 21-5037-2200

#### Authorized Distributor:

© OMRON Corporation 2006 All Rights Reserved.  
In the interest of product improvement,  
specifications are subject to change without notice.

Cat. No. H144-E1-04

Printed in Japan  
0908



# SCATTERGOOD & JOHNSON LTD

ELECTRICAL ENGINEERING & FLUID CONTROL DISTRIBUTORS

Est.1899

At Scattergood & Johnson Ltd, we pride ourselves on being a technical distributor to specialist industries.

Working with a range of quality product suppliers across a number of specialist markets, we are not your average 'box shifter' - we are your technical and supply chain partner.

We fully support every product we sell - for free! Our internal team and external sales engineers can answer any product or application question, no matter the complexity.

Backing up this technical ability is a range of 50,000+ products available from stock for nationwide next day delivery (same day if required!), or you can collect what you need from any of our trade counters around the UK.

Select your specialist interest below to learn more about how we can help.

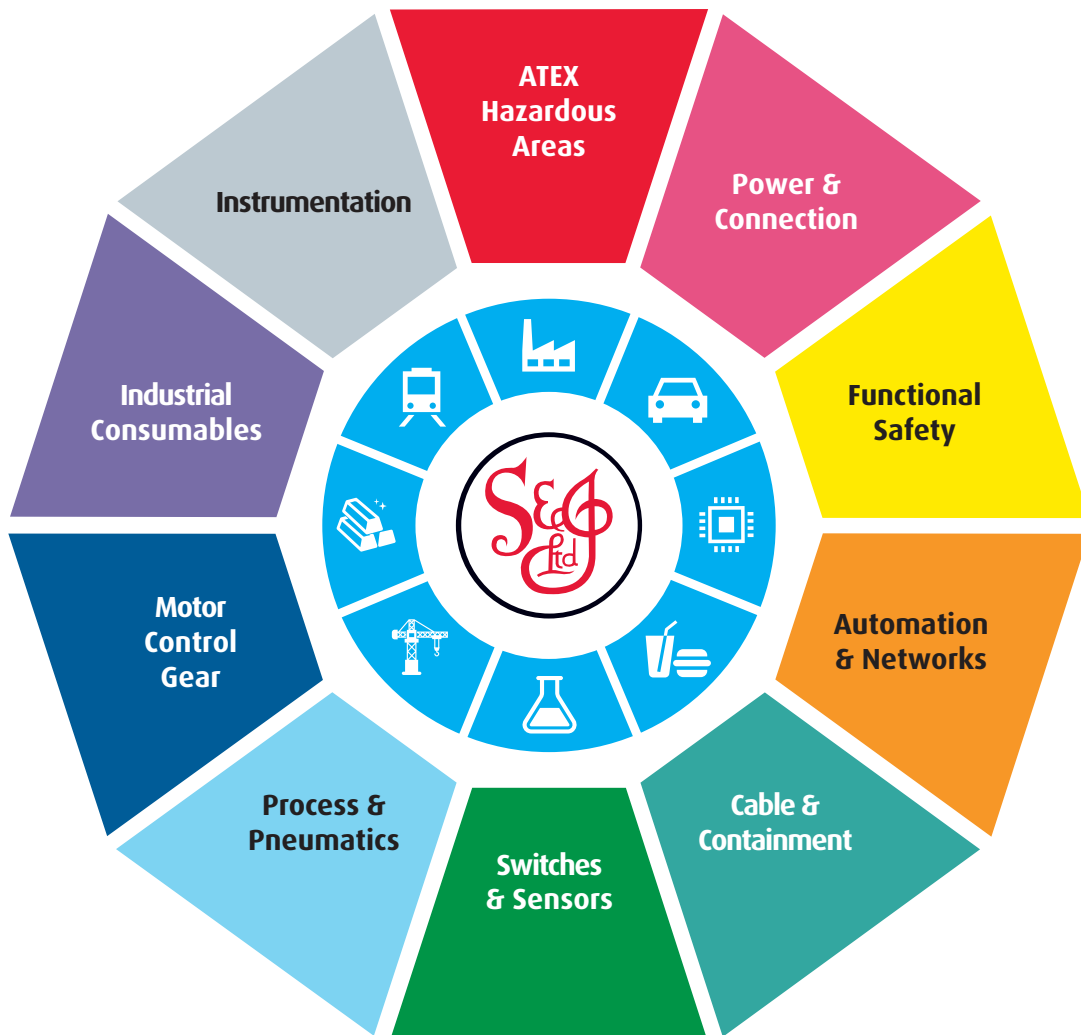

Online, In Branch and On the Road - Scattergood & Johnson Ltd, there when you need us.

# [www.scatts.co.uk](http://www.scatts.co.uk)