

# NX-series Temperature Control Unit

## NX-TC

### Optimize Control by Detecting Status Changes Easily Satisfy Both Productivity and Quality

- Provide optimal control for wide range of temperature control. Furthermore, automatically adapts to changes in the operating environment and measurement object conditions to realize optimum control. (Adaptive control)
- Functions specialized for packaging machines (Temperature Sensors for Packaging Machines and Automatic Filter Adjustment)
- Function specialized for water-cooled extruders (Watercooling Output Adjustment)
- Function for suppressing temperature variations that can be predicted (Disturbance Suppression)



NX-TC2405



NX-TC3405

## Features

- Build-in 2-or 4-loop (Ch) PID control or ON/OFF control functions not required temperature control programming
- With heater burnout alarm is available
- Multiple inputs for thermocouple and platinum resistance thermometer input models are available
- Detachable front connector with screwless Push-In Plus terminals for easy installation and maintenance
- Monitoring for ambient temperature is available
- Function added to Unit Versions 1.1 and later
  - A Temperature alarm is possible. (Includes an LBA: Loop Burnout Alarm)
  - Parameters are added to I/O data for adjustment of PID constants, etc.
  - Manipulated variable branching enables a manipulated variable with a calculated slope value or offset to be output to another channel.
- Function added to Unit Versions 1.2 and later
  - Disturbance Suppression (Pre-boost)
  - D-AT (Disturbance Autotuning)
  - Resistance thermometer Pt1000 can be input
- Function added to Unit Versions 1.3 and later
  - The first decimal place in input types "5: K -200 to 1300°C" and "0: Pt100 -200 to 850°C" can be counted as a significant figure.

Systemac is a trademark or registered trademark of OMRON Corporation in Japan and other countries for OMRON factory automation products. EtherCAT® is a registered trademark and patented technology, licensed by Beckhoff Automation GmbH, Germany. EtherNet/IP™ is a trademark of ODVA. Other company names and product names in this document are the trademarks or registered trademarks of their respective companies.

# NX-TC

## System Configurations

### Connected to a CPU Unit

The following figure shows a system configuration when NX Units are connected to an NX-series CPU Unit.

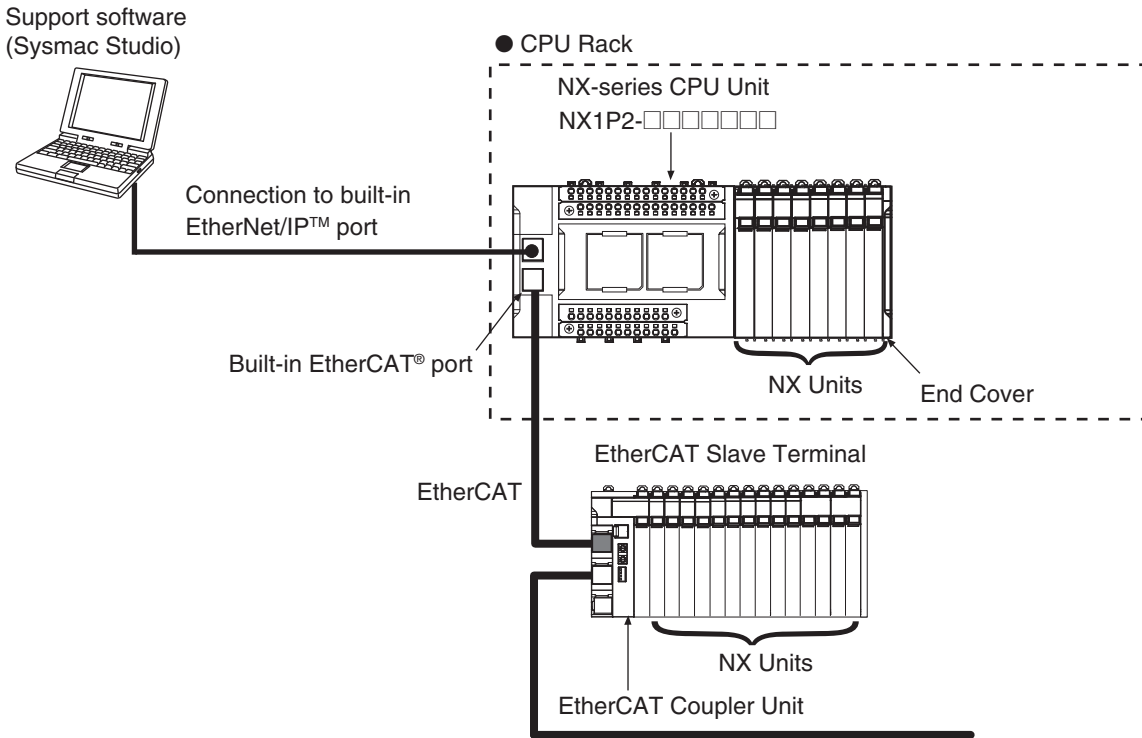

### Connected to an EtherCAT Coupler Unit

The following figure shows an example of the system configuration when an EtherCAT Coupler Unit is used as a Communications Coupler Unit.

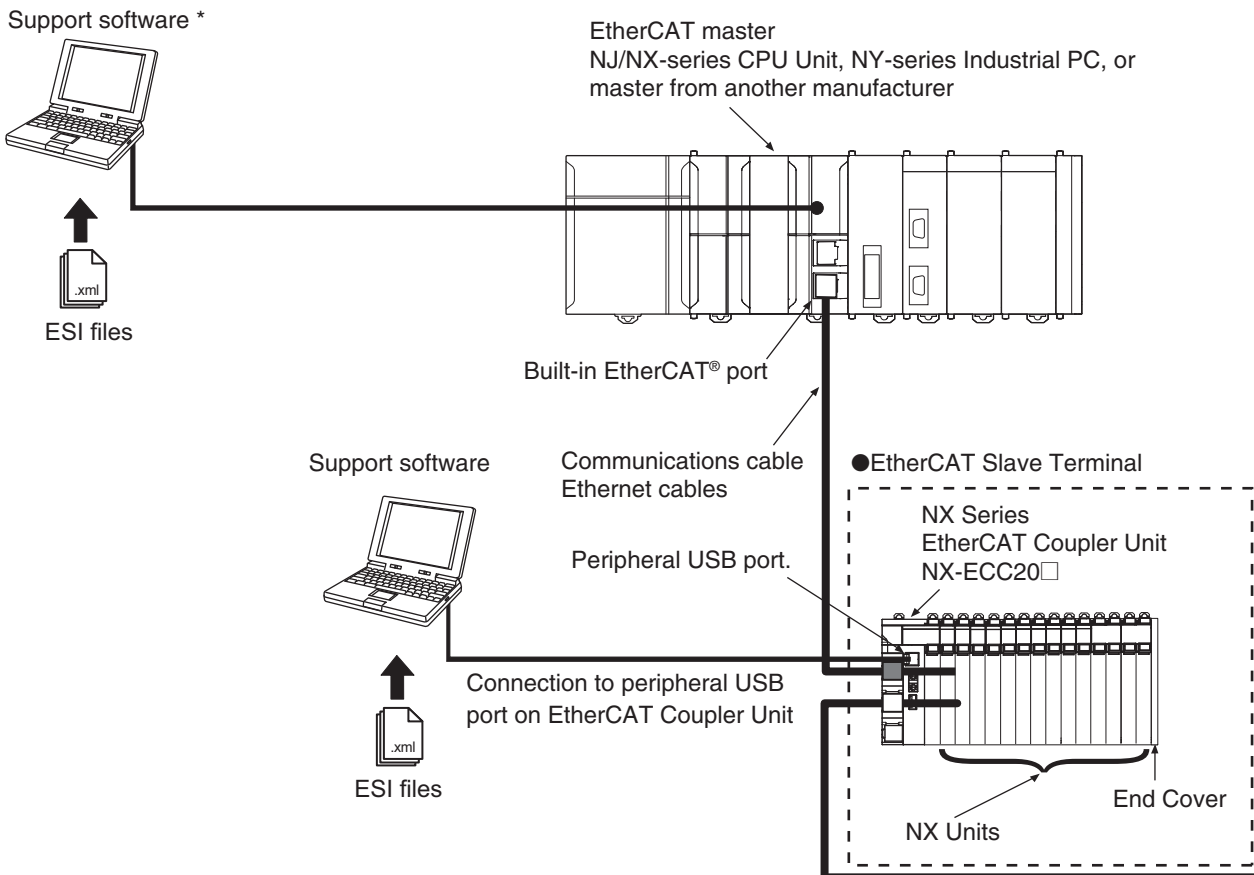

\* The connection method for the Sysmac Studio depends on the model of the CPU Unit or Industrial PC.

**Note:** To check whether NX Units can be connected to your CPU Unit or Communications Coupler Unit, refer to the user's manual for the CPU Unit or Communications Coupler Unit.

## Model Number Structure

**NX-TC**

(1) (2) (3)

### (1) Number of points

No.	Specification
2	2 points
3	4 points

### (2) I/O type

No.	Sensor type
4	Multi-input (Thermocouple and Resistance thermometer)

### (3) I/O type

No.	Control	Output		Number of CT input points per channel	I/O Refreshing Methods
		Output	Number of output points per channel		
05	Standard control	Voltage output (for driving SSR)	1 point per channel	1 point per channel	Free-Run refreshing
06			1 point per channel	None.	
07	Heating/cooling control		2 points per channel	None.	
08	Standard control	Linear current output	1 point per channel	None.	



# NX-TC

## Ordering Information

### Applicable standards

Refer to the OMRON website ([www.ia.omron.com](http://www.ia.omron.com)) or ask your OMRON representative for the most recent applicable standards for each model.

## Temperature Control Units

Unit type	Product name	Specification								Model
		Number of channels	Input type	Output	Output capacity	CT Input capacity	Control type	Conversion time	I/O refreshing method	
NX Series Temperature Control Unit	Temperature Control Unit 2Ch type 	2 Ch	Multi-input (Thermocouple and Resistance thermometer)	Voltage output (for driving SSR)	2 points	2 points	Standard Control	50 m sec	Free-Run refreshing	NX-TC2405
					None	Standard Control	NX-TC2406			
				Voltage output (for driving SSR)	4 points	None	Heating and Cooling Control			NX-TC2407
				Linear current output	2 points	None	Standard Control			NX-TC2408
	Temperature Control Unit 4Ch type 	4 Ch		Voltage output (for driving SSR)	4 points	4 points	Standard Control			NX-TC3405
					None	Standard Control	NX-TC3406			
				Voltage output (for driving SSR)	8 points	None	Heating and Cooling Control			NX-TC3407
				Linear current output	4 points	None	Standard Control			NX-TC3408

## Optional Products

Product name	Specification	Model
Unit/Terminal Block Coding Pins	Pins for 10 Units (30 terminal block pins and 30 Unit pins)	NX-AUX02

Product name	Specification	Model
Current Transformer (CT)	Hole diameter: 5.8 mm	E54-CT1
	Hole diameter: 5.8 mm	E54-CT1L *
	Hole diameter: 12.0 mm	E54-CT3
	Hole diameter: 12.0 mm	E54-CT3L *

\* Lead wires are included with these CTs. If UL certification is required, use these CTs.

## Accessories

Not included.

## General Specifications

Item		Specification
Enclosure		Mounted in a panel
Grounding method		Ground to 100 $\Omega$ or less
Operating environment	Ambient operating temperature	0 to 55°C
	Ambient operating humidity	10 to 95% RH (with no condensation or icing)
	Atmosphere	Must be free from corrosive gases.
	Ambient storage temperature	-25 to 70°C (with no condensation or icing)
	Altitude	2,000 m max.
	Pollution degree	Pollution degree 2 or less: Conforms to JIS B 3502 and IEC 61131-2.
	Noise immunity	Conforms to IEC 61000-4-4, 2 kV (power supply line)
	Overvoltage category	Category II: Conforms to JIS B 3502 and IEC 61131-2.
	EMC immunity level	Zone B
	Vibration resistance	Conforms to IEC 60068-2-6. 5 to 8.4 Hz with amplitude of 3.5 mm, 8.4 to 150 Hz, acceleration of 9.8 m/s <sup>2</sup> 100 min each in X, Y, and Z directions (10 sweeps of 10 min each = 100 min total)
	Shock resistance	Conforms to IEC 60068-2-27. 147 m/s <sup>2</sup> , 3 times each in X, Y, and Z directions
	Insulation resistance	20 M $\Omega$ min. between isolated circuits (at 100 VDC)
	Dielectric strength	510 VAC between isolated circuits for 1 minute at a leakage current of 5 mA max.
Applicable standards *		cULus: Listed (UL 61010-2-201), ANSI/ISA 12.12.01, EU: EN 61131-2, RCM, KC: KC Registration, EAC, NK, LR, BV

\* Refer to the OMRON website ([www.ia.omron.com](http://www.ia.omron.com)) or ask your OMRON representative for the most recent applicable standards for each model.

# NX-TC

## List of Functions

Function name		Description	Applicable units
Free-Run Refreshing		With this I/O refreshing method, the refresh cycle of the NX bus and the I/O refresh cycles of the NX Units are asynchronous.	All models
Selecting Channel To Use		This function disables control processing, error detection, and output for unused channels. The conversion time for its own Unit will not be shortened even if errors are disabled.	All models
Input Functions	Input Type Setting	This function sets the input type of the sensor connected to the temperature input.	All models
	Temperature Unit Setting (°C/°F)	This function sets the temperature units for measured values to °C (Celsius) or °F (Fahrenheit).	All models
	Decimal Point Position Setting	This function sets the number of digits to be displayed after the decimal point for INT type measured values and set point parameters.	All models
	Cold Junction Compensation Enable/Disable Setting	This function enables or disables cold junction compensation using the cold junction sensor that is mounted on the terminal block when a thermocouple input is used.	All models
	Temperature Input Correction	This function corrects measured values. When there are variations in the sensor or when there is a difference in measured value from other measuring instruments. One-point correction and two-point correction methods are provided.	All models
	Input Digital Filter	This function sets the time constant applied to the first-order lag operation filter so that the noise components mixed with the measured value are eliminated.	All models
	Measuring the Ambient Temperature Around Terminals	This function measures the temperature around the terminals of the Temperature Control Unit.	All models
Control Processing	ON/OFF control	This control function uses a preset set point to turn off the control output when the temperature reaches the set point during control.	All models
	PID control	PID control is a combination of proportional (P) control, integral (I) control, and differential (D) control. It is a control function that feeds back the detected value to the set point so that they conform to each other.	All models
	Heating/Cooling Control	This function controls both heating and cooling.	Heating/cooling control type models
	Run or Stop Controls	This function starts and stops temperature control.	All models
	Direct/Reverse Operation	This function specifies direct or reverse operation.	All models
	Manual MV (Manual Manipulated Variable)	This function outputs the specified manipulated variable during PID control.	All models
	MV at Error	This function outputs a fixed manipulated variable when a Sensor Disconnected Error occurs.	All models
	MV Limit	This function adds a limit to the manipulated variable calculated by PID control and outputs it.	All models
	Load Rejection MV	This function performs a preset output operation if the Temperature Control Unit connected to the CPU Unit cannot receive the output setting values from the CPU Unit due to an NX bus error or CPU watchdog timer error. This function performs a preset output operation if the Slave Terminal cannot receive the output setting values due to a communications error between the Temperature Control Unit and the Communications Coupler Unit host or due to an error on the NX bus.	All models
	MV Branch #1	The manipulated variables calculated by the slope or offset are output to the branch-destination channel based on the manipulated variables of the branch-source channel.	Standard control type models
Load Short-circuit Protection	This function protects output circuits of the Temperature Control Unit when an external device connected to the control output is short-circuited.	Models with voltage output (for driving SSR)	
Disturbance Suppression (Pre-boost) #2	This function suppresses temperature variations by adding a preset manipulated variable before temperature variations occur due to a disturbance.	Standard control type models	

Function name		Description	Applicable units
Tuning	AT (Autotuning)	This is a tuning method that derives the PID constant. This function automatically calculates the PID constant by the limit cycle method according to the characteristics of the control target.	All models
	Automatic Filter Adjustment	This is a tuning method that automatically adjusts the input digital filter. This function is primarily for packing machines. It suppresses periodic temperature variations.	Standard control type models
	Water-cooling Output Adjustment	This is a tuning method that automatically adjusts hunting. This function is primarily for water-cooled extruders. It suppresses temperature variations caused by the cooling water output.	Heating/cooling control type models
	Adaptive Control	This is a tuning method that can maintain high control performance by following system changes. This function maintains control performance even if temperature variation factors such as environmental change and equipment deterioration occur during a long-term equipment operation.	Standard control type models
	Notifying the Update of Tuning Parameters	This function notifies that the Temperature Control Unit has automatically updated the parameters by tuning.	All models
	D-AT (Disturbance Autotuning) *2	This function automatically calculates disturbance suppression (Pre-boost) function parameters such as FF waiting time, FF operation time, and FF segments 1 to 4 manipulated variables.	Standard control type models
Control Output	Control Period	This function sets the period when the ON/OFF time ratio is changed for voltage output (for driving SSR) in time-proportional operation.	Models with voltage output (for driving SSR)
	Minimum Output ON/OFF Band	This function specifies the minimum ON/OFF bands for the heating side control output or the cooling side control output. This function can be used to prevent deterioration of mechanical relays when mechanical relays are used in the actuators connected to the output terminals.	Models with voltage output (for driving SSR)
	Output Signal Range Setting	This function sets the output signal range of the linear current output. You can specify 4 to 20 mA or 0 to 20 mA.	Models with linear current output
	Limiting Simultaneous Outputs	This function limits the number of outputs that turn ON simultaneously by shifting the control period of each output and restricting the upper limit of the manipulated variable. You can set a delay between outputs, which allows delays in output device operation that can occur when outputs are switched.	Standard control type models with voltage output (for driving SSR)
Error Detection	Sensor Disconnection Detection	This function detects disconnections in temperature sensors. It also detects that the measured value of the temperature sensor is outside the input indication range.	All models
	Heater Burnout Detection	This function detects heater burnouts. A heater burnout is detected if the control output is ON and the heater current is equal to or less than the heater burnout detection current.	Models with CT input
	SSR Failure Detection	This function detects SSR failures. An SSR failure is detected if the control output is OFF and the leakage current is equal to or greater than the SSR failure detection current. An SSR failure is a failure that is caused by an SSR short-circuit.	Models with CT input
	Temperature alarms *1	Function for detecting a deviation or an error in the measured value as an alarm. Alarm operation corresponding to the use can be performed by selecting "Alarm type".	All models
	LBA (Loop Burnout Alarm) *1	Function for detecting, as an alarm, the error location in the control loop when there is no change in the measured value while a control deviation equal to or more than the threshold value exists between the set point and the measured value.	All models

\*1. Can be used with unit version Ver.1.1 or later.

\*2. Can be used with unit version Ver.1.2 or later.

## NX-TC

## Individual Specifications

## Temperature Control Unit (2-Channel Type) NX-TC2405

<b>Unit name</b>		Temperature Control Unit (2-Channel Type)	<b>Model</b>	NX-TC2405	
<b>Number of Channels</b>		2 channels	<b>Control type</b>	Standard control	
<b>Number of points per channel</b>		<ul style="list-style-type: none"> <li>Temperature input: 1 point per channel (2 points per unit)</li> <li>CT Input: 1 point per channel (2 points per unit)</li> <li>Control Output: 1 point per channel (2 points per unit)</li> </ul>	<b>External connection terminal</b>	Screwless clamping terminal block (16 terminals)	
<b>I/O refreshing method</b>		Free-Run Refreshing			
<b>Indicators</b>		TS indicator and output indicators 	<b>CT Input section</b>	<b>CT current input range</b>	0 to 0.125 A
				<b>Input resistance</b>	Approx. 2.7 Ω
				<b>Connectable CTs</b>	E54-CT1, E54-CT3, E54-CT1L, and E54-CT3L
				<b>Maximum heater current</b>	50 A AC
				<b>Resolution</b>	0.1 A
				<b>Overall accuracy (25°C)</b>	±5% (full scale) ±1 digit
				<b>Influence of temperature (0 to 55°C)</b>	±2% (full scale) ±1 digit
				<b>Conversion time</b>	50 ms/Unit
<b>Sensor Input section</b>		<ul style="list-style-type: none"> <li>Thermocouple input: K, J, T, E, L, U, N, R, S, B, C/W, PL II</li> <li>Platinum resistance thermometer input: Pt100 (three-wire), JPt100 (three-wire), Pt1000 (three-wire)</li> </ul>	<b>Control Output section</b>	<b>Control output type and number of control outputs per channel</b>	Voltage output for driving SSR, 1 point per channel
				<b>Internal I/O common</b>	PNP
				<b>Control Period</b>	0.1, 0.2, 0.5, 1 to 99s
				<b>Manipulated variable</b>	-5 to +105%
				<b>Resolution</b>	---
				<b>Rated Voltage</b>	24 VDC
				<b>Operating Load Voltage Range</b>	15 to 28.8 VDC
				<b>Maximum load current</b>	21 mA/point, 42 mA/Unit
				<b>Maximum Inrush Current</b>	0.3 A/point max., 10 ms max.
				<b>Allowable load resistance</b>	---
<b>Leakage current</b>	0.1 mA max.				
<b>Residual voltage</b>	1.5 V max.				
<b>Load Short-circuit Protection</b>	Provided				
<b>Output range</b>	---				
<b>Overall accuracy (25°C)</b>	---				
<b>Influence of temperature (0 to 55°C)</b>	---				
<b>Dimensions</b>		12 mm (W) × 100 mm (H) × 71 mm (D)	<b>Isolation method</b>	<ul style="list-style-type: none"> <li>Between sensor inputs and internal circuitry: Power = Transformer, Signal = Digital isolator</li> <li>Between inputs: Power = Transformer, Signal = Digital isolator</li> <li>No isolation between internal circuits and CT inputs</li> <li>Between control output and internal circuit: Photocoupler</li> <li>No isolation between control outputs</li> </ul>	
<b>Insulation resistance</b>		20 MΩ min. between isolated circuits (at 100 VDC)	<b>Dielectric strength</b>	510 VAC between isolated circuits for 1 minute with a leakage current of 5 mA max.	
<b>I/O power supply method</b>		Supplied from the NX bus.	<b>Current capacity of I/O power supply terminals</b>	IOG: 0.1 A max. per terminal	

<p><b>NX Unit power consumption</b></p>	<ul style="list-style-type: none"> <li>• Connected to a CPU Unit 1.45 W max.</li> <li>• Connected to Communications Coupler Unit 1.10 W max.</li> </ul>	<p><b>Current consumption from I/O power supply</b></p>	<p>20 mA max.</p>
---	---	---	-------------------

<p><b>Weight</b></p>	<p>75 g max.</p>
----------------------	------------------

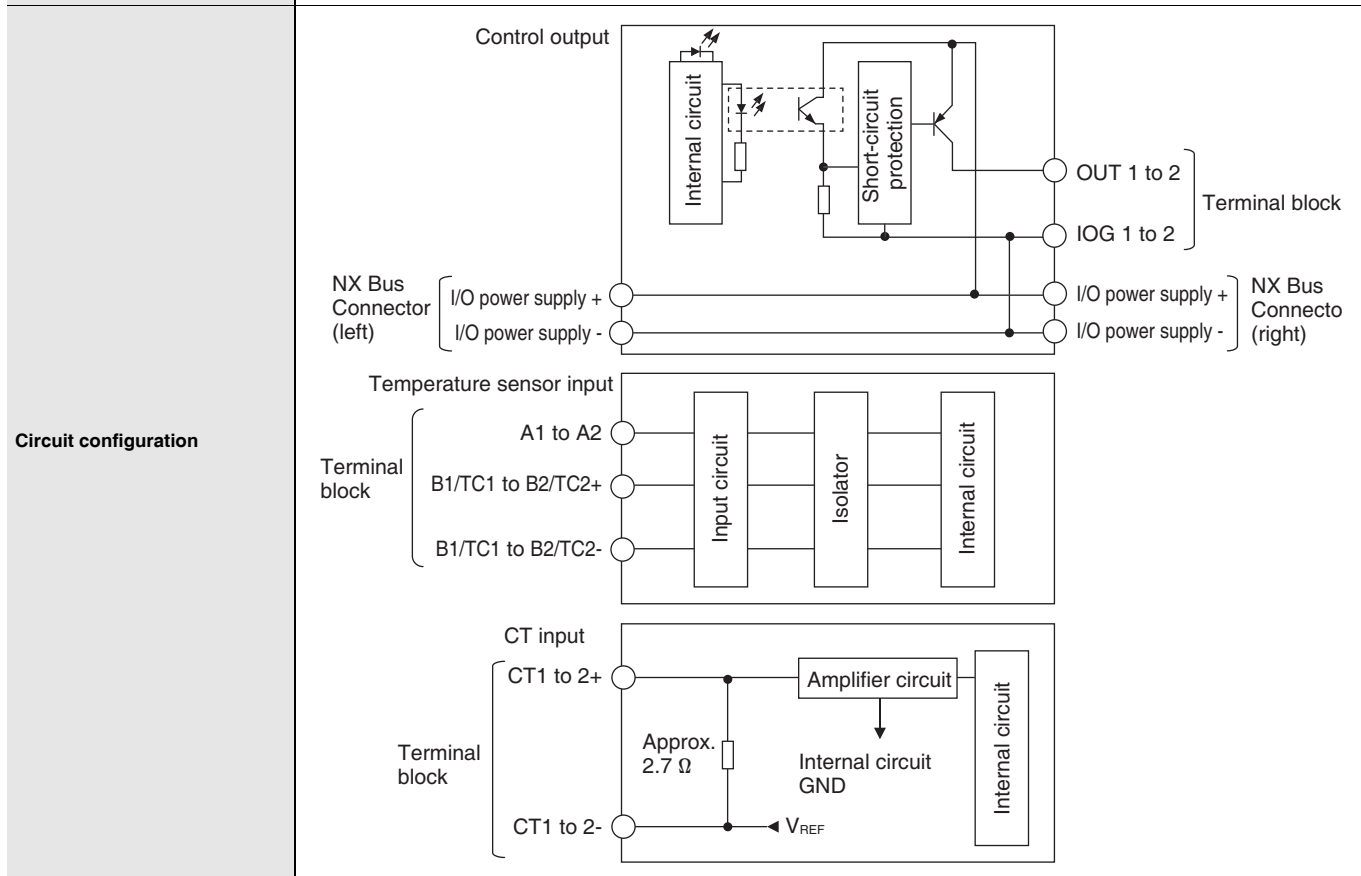

<p><b>Installation orientation and restrictions</b></p>	<p><b>Mounting orientation:</b></p> <ul style="list-style-type: none"> <li>• Connect to CPU unit Front mounting orientation is possible</li> <li>• Connect to communication coupler unit Six orientations are possible</li> </ul> <p><b>Limitation:</b> The cold junction compensation error is limited by the mounting orientation and the type or power consumption of the adjacent unit. For details, refer to <i>Cold Junction Compensation Error Specifications for Units That Take a Thermocouple Input Type</i> on page 27.</p>
---	--

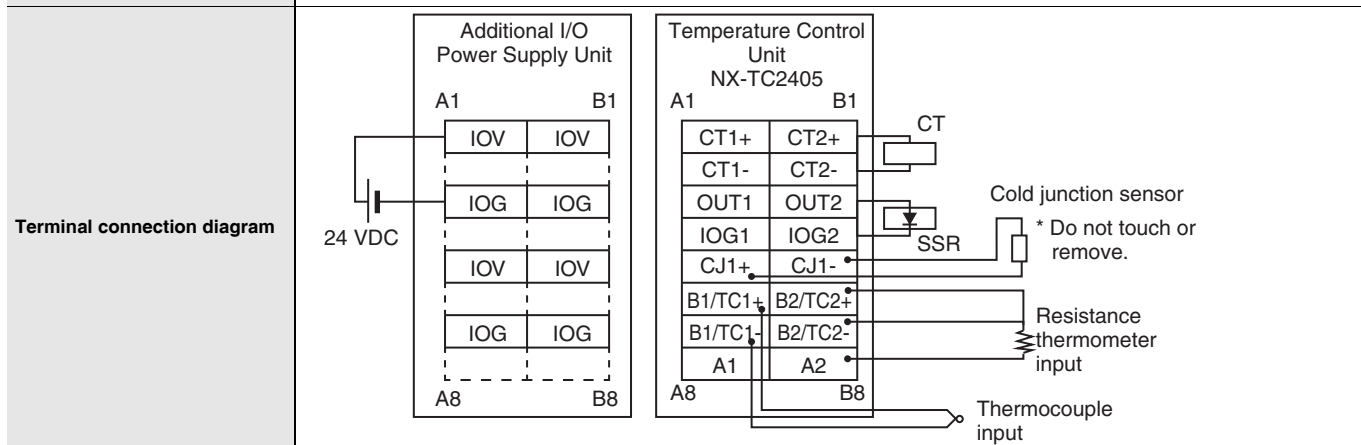

- \*1. For the setting ranges and indication ranges of the sensors, refer to the *Input types* on page 24.
- \*2. For details, refer to the *Reference Accuracy and Temperature Coefficient Table* on page 25.  
For thermocouple inputs, reference accuracy and cold junction compensation error are guaranteed for a set of a Temperature Control Unit and a terminal block on which a cold junction sensor is mounted.  
Be sure to use the terminal block and the Temperature Control Unit with the same calibration control number together.  
A calibration control number is displayed both on the terminal block and the Unit.  
Make sure to return the terminal block to which a cold junction sensor is mounted and the Unit together.
- \*3. For details, refer to *Cold Junction Compensation Error Specifications for Units That Take a Thermocouple Input Type* on page 27.

## NX-TC

## Temperature Control Unit (2-Channel Type) NX-TC2406

<b>Unit name</b>		Temperature Control Unit (2-Channel Type)	<b>Model</b>	NX-TC2406	
<b>Number of Channels</b>		2 channels	<b>Control type</b>	Standard control	
<b>Number of points per channel</b>		<ul style="list-style-type: none"> <li>Temperature input: 1 point per channel (2 points per unit)</li> <li>CT input: None</li> <li>Control Output: 1 point per channel (2 points per unit)</li> </ul>	<b>External connection terminal</b>	Screwless clamping terminal block (16 terminals)	
<b>I/O refreshing method</b>		Free-Run Refreshing			
<b>Indicators</b>		TS indicator and output indicators			
					
		<b>CT Input section</b>	<b>CT current input range</b>	---	
			<b>Input resistance</b>	---	
			<b>Connectable CTs</b>	---	
			<b>Maximum heater current</b>	---	
			<b>Resolution</b>	---	
			<b>Overall accuracy (25°C)</b>	---	
			<b>Influence of temperature (0 to 55°C)</b>	---	
		<b>Conversion time</b>	---		
<b>Sensor Input section</b>	<b>Temperature sensor *1</b>	<ul style="list-style-type: none"> <li>Thermocouple input: K, J, T, E, L, U, N, R, S, B, C/W, PL II</li> <li>Platinum resistance thermometer input: Pt100 (three-wire), JPt100 (three-wire), Pt1000 (three-wire)</li> </ul>			
		<b>Input conversion range</b>	±20°C of the input range *2		
		<b>Absolute maximum rating</b>	±130 mV		
		<b>Input impedance</b>	20 kΩ min.		
		<b>Resolution</b>	0.1°C max.		
		<b>Reference accuracy</b>	*2		
		<b>Temperature coefficient</b>	*2		
		<b>Cold junction compensation error</b>	±1.2°C *2 *3		
		<b>Input disconnection detection current</b>	Approx. 0.1 uA		
		<b>Input detection current</b>	0.25 mA		
<b>Control Output section</b>	<b>Temperature sensor *1</b>	<ul style="list-style-type: none"> <li>Thermocouple input: 0.1°C/Ω (100 Ω or less per conductor)</li> <li>Platinum resistance thermometer input: 0.06°C/Ω (20 Ω or less per conductor)</li> </ul>			
		<b>Warm-up period</b>	30 minutes		
		<b>Conversion time</b>	50 ms/Unit		
		<b>Control output type and number of control outputs per channel</b>	Voltage output for driving SSR, 1 point per channel		
		<b>Internal I/O common</b>	PNP		
		<b>Control Period</b>	0.1, 0.2, 0.5, 1 to 99s		
		<b>Manipulated variable</b>	-5 to +105%		
		<b>Resolution</b>	---		
		<b>Rated Voltage</b>	24 VDC		
		<b>Operating Load Voltage Range</b>	15 to 28.8 VDC		
<b>Dimensions</b>	<b>Temperature sensor *1</b>	<b>Maximum load current</b>	21 mA/point, 42 mA/Unit		
		<b>Maximum Inrush Current</b>	0.3 A/point max., 10 ms max.		
		<b>Allowable load resistance</b>	---		
		<b>Leakage current</b>	0.1 mA max.		
		<b>Residual voltage</b>	1.5 V max.		
		<b>Load Short-circuit Protection</b>	Provided		
		<b>Output range</b>	---		
		<b>Overall accuracy (25°C)</b>	---		
		<b>Influence of temperature (0 to 55°C)</b>	---		
		<b>Isolation method</b>	<ul style="list-style-type: none"> <li>Between sensor inputs and internal circuitry: Power = Transformer, Signal = Digital isolator</li> <li>Between inputs: Power = Transformer, Signal = Digital isolator</li> <li>Between control output and internal circuit: Photocoupler</li> <li>No isolation between control outputs</li> </ul>		
<b>Insulation resistance</b>	20 MΩ min. between isolated circuits (at 100 VDC)	<b>Dielectric strength</b>	510 VAC between isolated circuits for 1 minute with a leakage current of 5 mA max.		
<b>I/O power supply method</b>	Supplied from the NX bus.	<b>Current capacity of I/O power supply terminals</b>	IOG: 0.1 A max. per terminal		

<p><b>NX Unit power consumption</b></p>	<ul style="list-style-type: none"> <li>• Connected to a CPU Unit 1.25 W max.</li> <li>• Connected to Communications Coupler Unit 0.95 W max.</li> </ul>	<p><b>Current consumption from I/O power supply</b></p>	<p>20 mA max.</p>
---	---	---	-------------------

<p><b>Weight</b></p>	<p>75 g max.</p>
----------------------	------------------

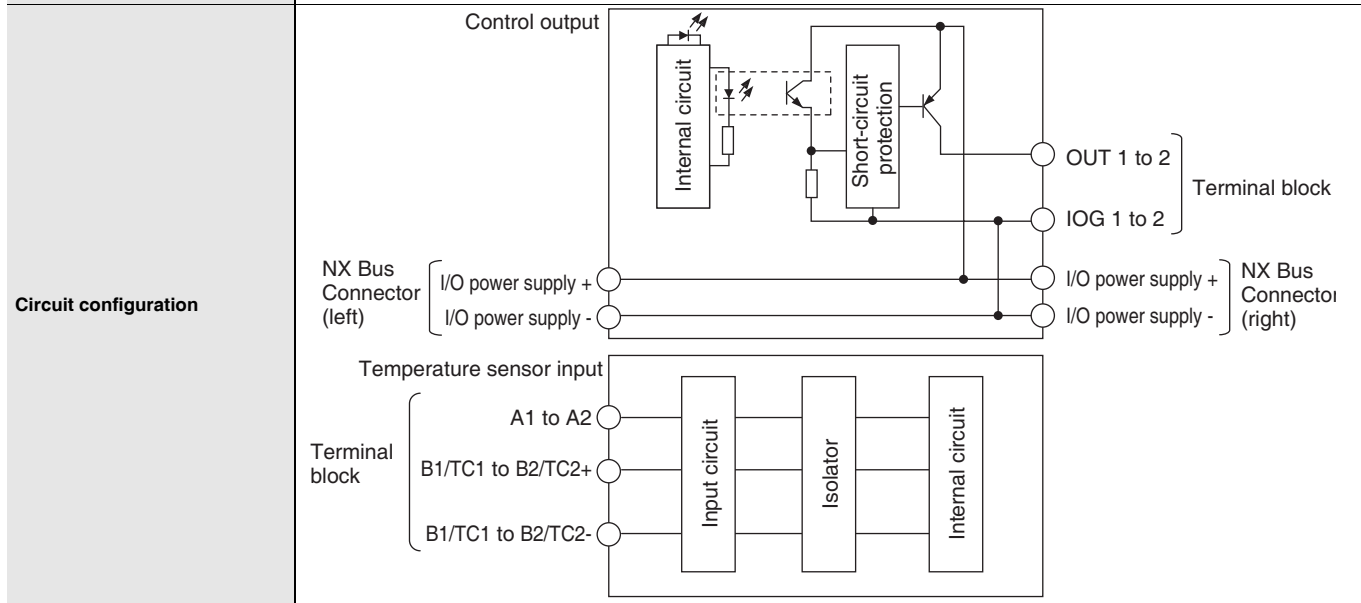

**Installation orientation and restrictions**

Mounting orientation:

- Connect to CPU unit
- Front mounting orientation is possible
- Connect to communication coupler unit
- Six orientations are possible

Limitation:

The cold junction compensation error is limited by the mounting orientation and the type or power consumption of the adjacent unit. For details, refer to *Cold Junction Compensation Error Specifications for Units That Take a Thermocouple Input Type* on page 27.

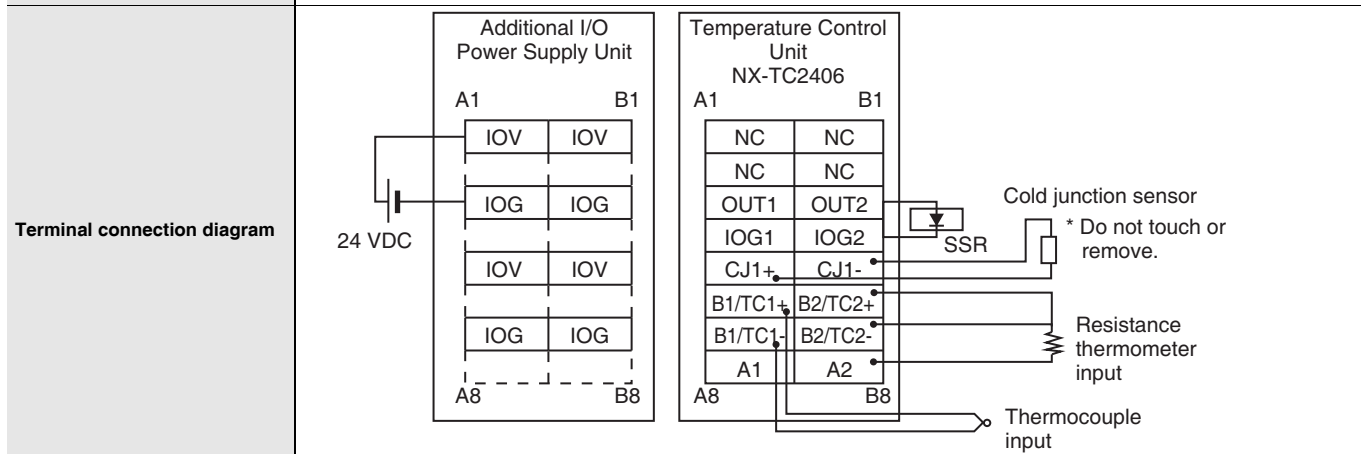

- \*1. For the setting ranges and indication ranges of the sensors, refer to the *Input types* on page 24.
- \*2. For details, refer to the *Reference Accuracy and Temperature Coefficient Table* on page 25.  
For thermocouple inputs, reference accuracy and cold junction compensation error are guaranteed for a set of a Temperature Control Unit and a terminal block on which a cold junction sensor is mounted.  
Be sure to use the terminal block and the Temperature Control Unit with the same calibration control number together.  
A calibration control number is displayed both on the terminal block and the Unit.  
Make sure to return the terminal block to which a cold junction sensor is mounted and the Unit together.
- \*3. For details, refer to *Cold Junction Compensation Error Specifications for Units That Take a Thermocouple Input Type* on page 27.

## NX-TC

## Temperature Control Unit (2-Channel Type) NX-TC2407

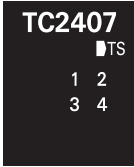
<b>Unit name</b>		Temperature Control Unit (2-Channel Type)	<b>Model</b>	NX-TC2407	
<b>Number of Channels</b>		2 channels	<b>Control type</b>	Heating and cooling control	
<b>Number of points per channel</b>		<ul style="list-style-type: none"> <li>Temperature input: 1 point per channel (2 points per unit)</li> <li>CT input: None</li> <li>Control Output: 2 point per channel (4 points per unit)</li> </ul>	<b>External connection terminal</b>	Screwless clamping terminal block (16 terminals)	
<b>I/O refreshing method</b>		Free-Run Refreshing			
<b>Indicators</b>		TS indicator and output indicators			
					
		<b>CT Input section</b>	<b>CT current input range</b>	---	
			<b>Input resistance</b>	---	
			<b>Connectable CTs</b>	---	
			<b>Maximum heater current</b>	---	
			<b>Resolution</b>	---	
			<b>Overall accuracy (25°C)</b>	---	
			<b>Influence of temperature (0 to 55°C)</b>	---	
		<b>Conversion time</b>	---		
<b>Sensor Input section</b>	<b>Temperature sensor *1</b>	<ul style="list-style-type: none"> <li>Thermocouple input: K, J, T, E, L, U, N, R, S, B, C/W, PL II</li> <li>Platinum resistance thermometer input: Pt100 (three-wire), JPt100 (three-wire), Pt1000 (three-wire)</li> </ul>			
		<b>Input conversion range</b>	±20°C of the input range *2		
		<b>Absolute maximum rating</b>	±130 mV		
		<b>Input impedance</b>	20 kΩ min.		
		<b>Resolution</b>	0.1°C max.		
		<b>Reference accuracy</b>	*2		
		<b>Temperature coefficient</b>	*2		
		<b>Cold junction compensation error</b>	±1.2°C *2 *3		
		<b>Input disconnection detection current</b>	Approx. 0.1 uA		
		<b>Input detection current</b>	0.25 mA		
<b>Control Output section</b>	<b>Temperature sensor *1</b>	<ul style="list-style-type: none"> <li>Thermocouple input: 0.1°C/Ω (100Ω or less per conductor)</li> <li>Platinum resistance thermometer input: 0.06°C/Ω (20 Ω or less per conductor)</li> </ul>			
		<b>Warm-up period</b>	30 minutes		
		<b>Conversion time</b>	50 ms/Unit		
		<b>Control output type and number of control outputs per channel</b>	Voltage output for driving SSR, 2 point per channel		
		<b>Internal I/O common</b>	PNP		
		<b>Control Period</b>	0.1, 0.2, 0.5, 1 to 99s		
		<b>Manipulated variable</b>	<ul style="list-style-type: none"> <li>Heating: 0 to +105%</li> <li>Cooling: 0 to +105%</li> </ul>		
		<b>Resolution</b>	---		
		<b>Rated Voltage</b>	24 VDC		
		<b>Operating Load Voltage Range</b>	15 to 28.8 VDC		
<b>Dimensions</b>	<b>Control Output section</b>	<b>Maximum load current</b>	21 mA/point, 84 mA/Unit		
		<b>Maximum Inrush Current</b>	0.3 A/point max., 10 ms max.		
		<b>Allowable load resistance</b>	---		
		<b>Leakage current</b>	0.1 mA max.		
		<b>Residual voltage</b>	1.5 V max.		
		<b>Load Short-circuit Protection</b>	Provided		
		<b>Output range</b>	---		
		<b>Overall accuracy (25°C)</b>	---		
		<b>Influence of temperature (0 to 55°C)</b>	---		
		<b>Isolation method</b>	<ul style="list-style-type: none"> <li>Between sensor inputs and internal circuitry: Power = Transformer, Signal = Digital isolator</li> <li>Between inputs: Power = Transformer, Signal = Digital isolator</li> <li>Between control output and internal circuit: Photocoupler</li> <li>No isolation between control outputs</li> </ul>		
<b>Insulation resistance</b>	20 MΩ min. between isolated circuits (at 100 VDC)	<b>Dielectric strength</b>	510 VAC between isolated circuits for 1 minute with a leakage current of 5 mA max.		
<b>I/O power supply method</b>	Supplied from the NX bus.	<b>Current capacity of I/O power supply terminals</b>	IOG: 0.1 A max. per terminal		

<p><b>NX Unit power consumption</b></p>	<ul style="list-style-type: none"> <li>• Connected to a CPU Unit 1.30 W max.</li> <li>• Connected to Communications Coupler Unit 1.00 W max.</li> </ul>	<p><b>Current consumption from I/O power supply</b></p>	<p>20 mA max.</p>
<p><b>Weight</b></p>	<p>75 g max.</p>		
<p><b>Circuit configuration</b></p>	<p>The diagram illustrates the internal and external circuitry of the NX-TC unit. It shows an internal circuit with a short-circuit protection mechanism. The unit is connected to an NX Bus Connector (left) for I/O power supply (+ and -) and an NX Bus Connector (right) for I/O power supply (+ and -). The output is connected to a Terminal block (OUT 1 to 4 and IOG 1 to 4). The temperature sensor input is connected to a Terminal block (A1 to A2, B1/TC1 to B2/TC2+, and B1/TC1 to B2/TC2-), which is then connected to an Input circuit, an Isolator, and an Internal circuit.</p>		
<p><b>Installation orientation and restrictions</b></p>	<p>Mounting orientation:</p> <ul style="list-style-type: none"> <li>• Connect to CPU unit</li> <li>• Front mounting orientation is possible</li> <li>• Connect to communication coupler unit</li> <li>• Six orientations are possible</li> </ul> <p>Limitation: The cold junction compensation error is limited by the mounting orientation and the type or power consumption of the adjacent unit. For details, refer to <i>Cold Junction Compensation Error Specifications for Units That Take a Thermocouple Input Type</i> on page 27.</p>		
<p><b>Terminal connection diagram</b></p>	<p>The diagram shows the terminal connections for the NX-TC2407 unit. It includes an Additional I/O Power Supply Unit and a Temperature Control Unit. The connections are as follows:</p> <ul style="list-style-type: none"> <li>Additional I/O Power Supply Unit: A1, B1, A8, B8. IOV, IOG.</li> <li>Temperature Control Unit: A1, B1, A8, B8. OUT1, OUT2, OUT3, OUT4, IOG1, IOG2, IOG3, IOG4, CJ1+, CJ1-, B1/TC1+, B2/TC2+, B1/TC1-, B2/TC2-, A1, A2, Thermocouple input.</li> <li>SSR (Solid State Relay) connections to OUT1, OUT2, OUT3, OUT4.</li> <li>Cold junction sensor connection to CJ1+ and CJ1-.</li> <li>Resistance thermometer input connection to B1/TC1+ and B2/TC2+.</li> <li>24 VDC power supply connection to the Additional I/O Power Supply Unit.</li> </ul> <p>* Do not touch or remove.</p>		

\*1. For the setting ranges and indication ranges of the sensors, refer to the *Input types* on page 24.

\*2. For details, refer to the *Reference Accuracy and Temperature Coefficient Table* on page 25.

For thermocouple inputs, reference accuracy and cold junction compensation error are guaranteed for a set of a Temperature Control Unit and a terminal block on which a cold junction sensor is mounted.

Be sure to use the terminal block and the Temperature Control Unit with the same calibration control number together.

A calibration control number is displayed both on the terminal block and the Unit.

Make sure to return the terminal block to which a cold junction sensor is mounted and the Unit together.

\*3. For details, refer to *Cold Junction Compensation Error Specifications for Units That Take a Thermocouple Input Type* on page 27.

## NX-TC

## Temperature Control Unit (2-Channel Type) NX-TC2408

<b>Unit name</b>		Temperature Control Unit (2-Channel Type)	<b>Model</b>	NX-TC2408		
<b>Number of Channels</b>		2 channels	<b>Control type</b>	Standard control		
<b>Number of points per channel</b>		<ul style="list-style-type: none"> <li>Temperature input: 1 point per channel (2 points per unit)</li> <li>CT input: None</li> <li>Control Output: 1 point per channel (2 points per unit)</li> </ul>	<b>External connection terminal</b>	Screwless clamping terminal block (16 terminals)		
<b>I/O refreshing method</b>		Free-Run Refreshing				
<b>Indicators</b>		TS indicator and output indicators				
					<b>CT current input range</b>	---
					<b>Input resistance</b>	---
					<b>Connectable CTs</b>	---
					<b>Maximum heater current</b>	---
					<b>Resolution</b>	---
					<b>Overall accuracy (25°C)</b>	---
					<b>Influence of temperature (0 to 55°C)</b>	---
		<b>Conversion time</b>	---			
		<b>Sensor Input section</b>		<ul style="list-style-type: none"> <li>Thermocouple input: K, J, T, E, L, U, N, R, S, B, C/W, PL II</li> <li>Platinum resistance thermometer input: Pt100 (three-wire), JPt100 (three-wire), Pt1000 (three-wire)</li> </ul>		
<b>Internal I/O common</b>	---					
<b>Control Period</b>	---					
<b>Manipulated variable</b>	-5 to +105%					
<b>Resolution</b>	1/10,000					
<b>Rated Voltage</b>	24 VDC					
<b>Operating Load Voltage Range</b>	15 to 28.8 VDC					
<b>Maximum load current</b>	---					
<b>Maximum Inrush Current</b>	---					
<b>Allowable load resistance</b>	350 Ω or less, or greater than 350 Ω but no more than 600 Ω *3					
<b>Leakage current</b>	---					
<b>Residual voltage</b>	---					
<b>Load Short-circuit Protection</b>	---					
<b>Output range</b>	0 to 20 mA, 4 to 20 mA					
<b>Overall accuracy (25°C)</b>	±0.3% of full scale, but 1% of full scale at 0 to 4 mA of 0 to 20 mA range					
<b>Influence of temperature (0 to 55°C)</b>	±0.3% (full scale)					
<b>Dimensions</b>		12 mm (W) × 100 mm (H) × 71 mm (D)	<b>Isolation method</b>	<ul style="list-style-type: none"> <li>Between sensor inputs and internal circuitry: Power = Transformer, Signal = Digital isolator</li> <li>Between inputs: Power = Transformer, Signal = Digital isolator</li> <li>Between control output and internal circuit: Photocoupler</li> <li>No isolation between control outputs</li> </ul>		
<b>Insulation resistance</b>		20 MΩ min. between isolated circuits (at 100 VDC)	<b>Dielectric strength</b>	510 VAC between isolated circuits for 1 minute with a leakage current of 5 mA max.		
<b>I/O power supply method</b>		Supplied from the NX bus.	<b>Current capacity of I/O power supply terminals</b>	IOG: 0.1 A max. per terminal		

<b>NX Unit power consumption</b>	<ul style="list-style-type: none"> <li>• Connected to a CPU Unit 1.25 W max.</li> <li>• Connected to Communications Coupler Unit 0.95 W max.</li> </ul>	<b>Current consumption from I/O power supply</b>	20 mA max.
----------------------------------	---	--	------------

<b>Weight</b>	75 g max.
---------------	-----------

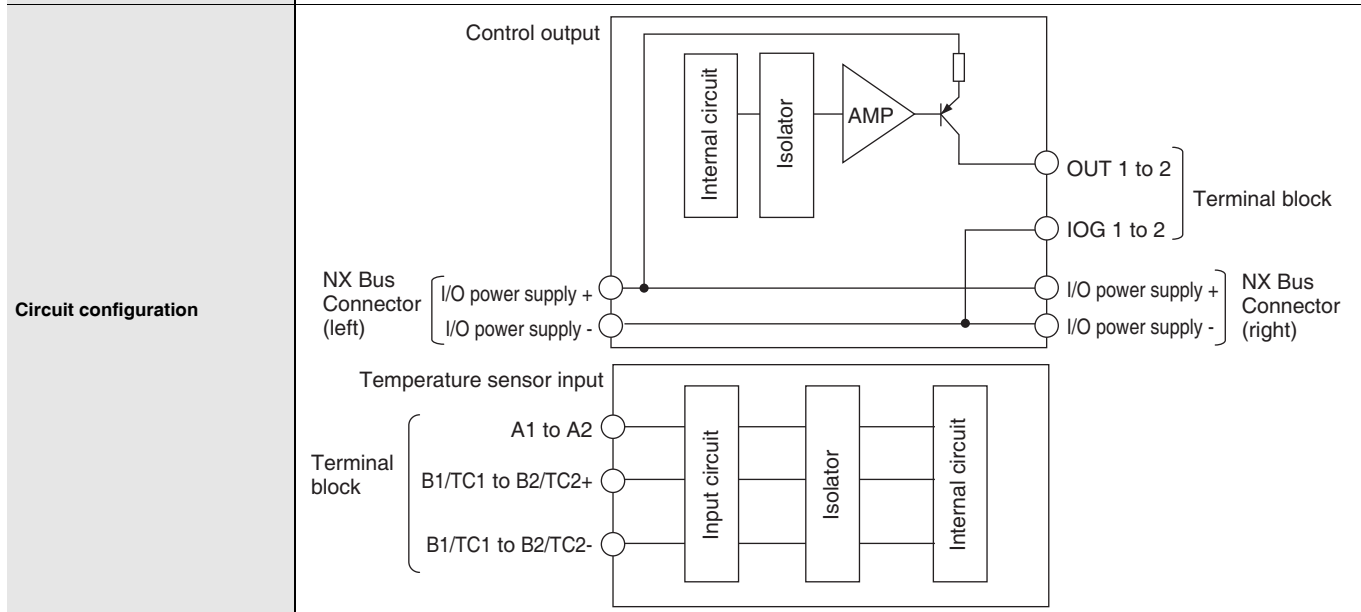

**Installation orientation and restrictions**

Mounting orientation:

- Connect to CPU unit  
Front mounting orientation is possible
- Connect to communication coupler unit  
Six orientations are possible

Limitation:  
The cold junction compensation error is limited by the mounting orientation and the type or power consumption of the adjacent unit. For details, refer to *Cold Junction Compensation Error Specifications for Units That Take a Thermocouple Input Type* on page 27.

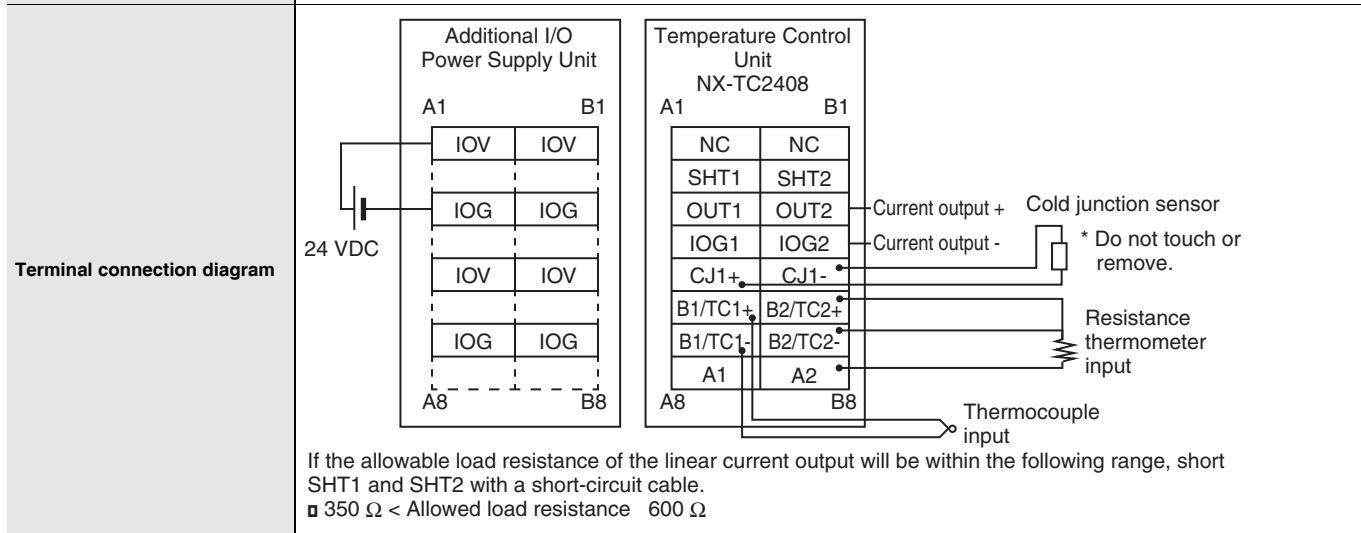

- \*1. For the setting ranges and indication ranges of the sensors, refer to the *Input types* on page 24.
- \*2. For details, refer to the *Reference Accuracy and Temperature Coefficient Table* on page 25.  
 For thermocouple inputs, reference accuracy and cold junction compensation error are guaranteed for a set of a Temperature Control Unit and a terminal block on which a cold junction sensor is mounted.  
 Be sure to use the terminal block and the Temperature Control Unit with the same calibration control number together.  
 A calibration control number is displayed both on the terminal block and the Unit.  
 Make sure to return the terminal block to which a cold junction sensor is mounted and the Unit together.
- \*3. To use an allowable load resistance greater than 350 Ω but not exceeding 600 Ω, SHT1 and SHT2 must be shorted with a shorting cable.  
 For details, refer to the *NX-series Temperature Control Units User's Manual* (Cat. No. W523).
- \*4. For details, refer to *Cold Junction Compensation Error Specifications for Units That Take a Thermocouple Input Type* on page 27.

## NX-TC

## Temperature Control Unit (4-Channel Type) NX-TC3405

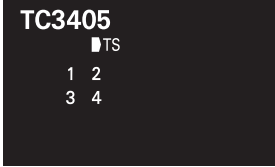
<b>Unit name</b>		Temperature Control Unit (4-Channel Type)	<b>Model</b>	NX-TC3405	
<b>Number of Channels</b>		4 channels	<b>Control type</b>	Standard control	
<b>Number of points per channel</b>		<ul style="list-style-type: none"> <li>Temperature input: 1 point per channel (4 points per unit)</li> <li>CT Input: 1 point per channel (4 points per unit)</li> <li>Control Output: 1 point per channel (4 points per unit)</li> </ul>	<b>External connection terminal</b>	Screwless clamping terminal block (16 terminals x 2)	
<b>I/O refreshing method</b>		Free-Run Refreshing			
<b>Indicators</b>		TS indicator and output indicators 	<b>CT Input section</b>	<b>CT current input range</b>	0 to 0.125 A
				<b>Input resistance</b>	Approx. 2.7 Ω
				<b>Connectable CTs</b>	E54-CT1, E54-CT3, E54-CT1L, and E54-CT3L
				<b>Maximum heater current</b>	50 A AC
				<b>Resolution</b>	0.1 A
				<b>Overall accuracy (25°C)</b>	±5% (full scale) ±1 digit
				<b>Influence of temperature (0 to 55°C)</b>	±2% (full scale) ±1 digit
				<b>Conversion time</b>	50 ms/Unit
<b>Sensor Input section</b>		<ul style="list-style-type: none"> <li>Thermocouple input: K, J, T, E, L, U, N, R, S, B, C/W, PL II</li> <li>Platinum resistance thermometer input: Pt100 (three-wire), JPt100 (three-wire), Pt1000 (three-wire)</li> </ul>	<b>Control Output section</b>	<b>Control output type and number of control outputs per channel</b>	Voltage output for driving SSR, 1 point per channel
				<b>Internal I/O common</b>	PNP
				<b>Control Period</b>	0.1, 0.2, 0.5, 1 to 99s
				<b>Manipulated variable</b>	-5 to +105%
				<b>Resolution</b>	---
				<b>Rated Voltage</b>	24 VDC
				<b>Operating Load Voltage Range</b>	15 to 28.8 VDC
				<b>Maximum load current</b>	21 mA/point, 84 mA/Unit
				<b>Maximum Inrush Current</b>	0.3 A/point max., 10 ms max.
				<b>Allowable load resistance</b>	---
				<b>Leakage current</b>	0.1 mA max.
				<b>Residual voltage</b>	1.5 V max.
<b>Load Short-circuit Protection</b>	Provided				
<b>Output range</b>	---				
<b>Overall accuracy (25°C)</b>	---				
<b>Influence of temperature (0 to 55°C)</b>	---				
<b>Dimensions</b>		24 mm (W) × 100 mm (H) × 71 mm (D)	<b>Isolation method</b>	<ul style="list-style-type: none"> <li>Between sensor inputs and internal circuitry: Power = Transformer, Signal = Digital isolator</li> <li>Between inputs: Power = Transformer, Signal = Digital isolator</li> <li>No isolation between internal circuits and CT inputs</li> <li>Between control output and internal circuit: Photocoupler</li> <li>No isolation between control outputs</li> </ul>	
<b>Insulation resistance</b>		20 MΩ min. between isolated circuits (at 100 VDC)	<b>Dielectric strength</b>	510 VAC between isolated circuits for 1 minute with a leakage current of 5 mA max.	
<b>I/O power supply method</b>		Supplied from the NX bus.	<b>Current capacity of I/O power supply terminals</b>	I/O: 0.1 A max. per terminal	

<b>NX Unit power consumption</b>	<ul style="list-style-type: none"> <li>• Connected to a CPU Unit 1.80 W max.</li> <li>• Connected to Communications Coupler Unit 1.35 W max.</li> </ul>	<b>Current consumption from I/O power supply</b>	20 mA max.
----------------------------------	---	--	------------

<b>Weight</b>	140 g max.
---------------	------------

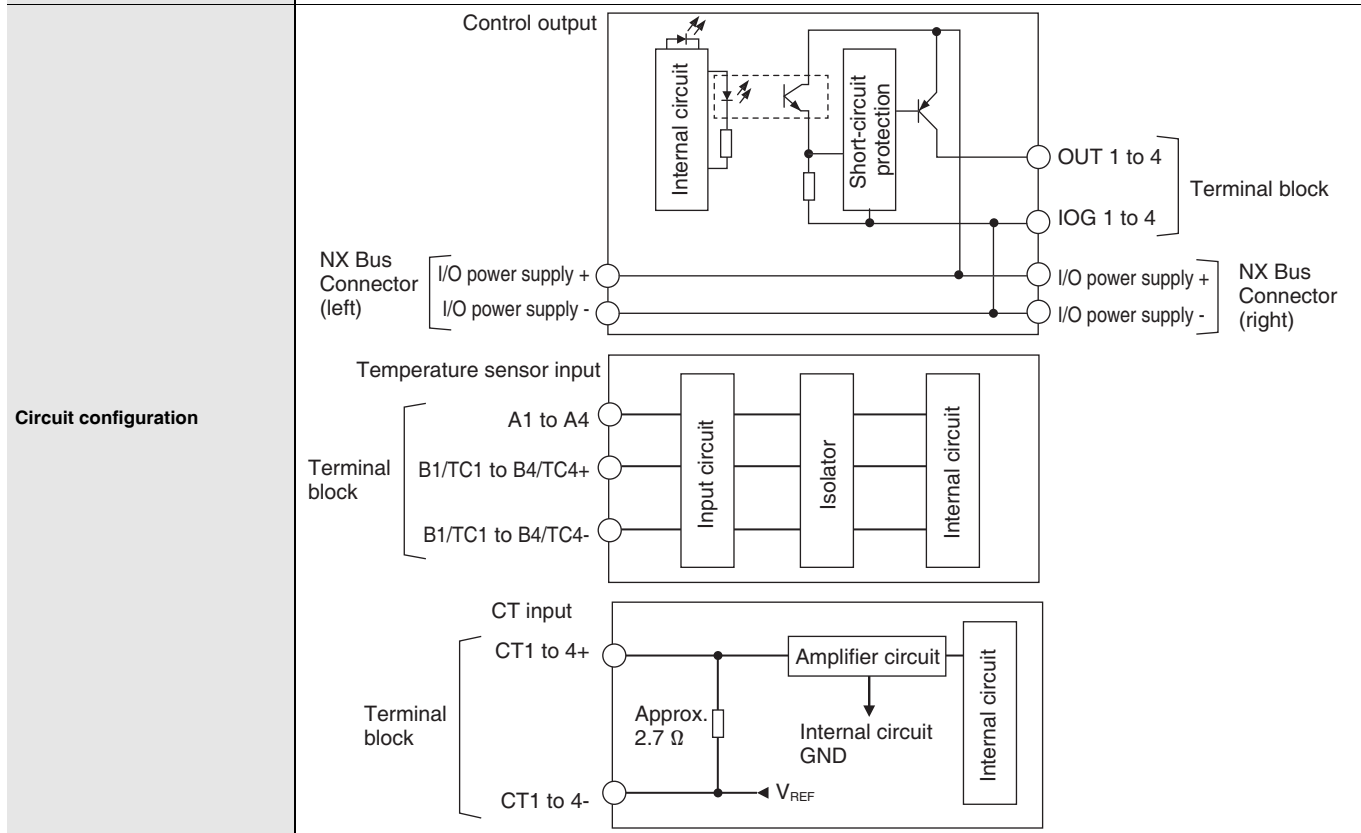

**Installation orientation and restrictions**

Mounting orientation:

- Connect to CPU unit
- Front mounting orientation is possible
- Connect to communication coupler unit
- Six orientations are possible

Limitation:  
The cold junction compensation error is limited by the mounting orientation and the type or power consumption of the adjacent unit. For details, refer to *Cold Junction Compensation Error Specifications for Units That Take a Thermocouple Input Type* on page 27.

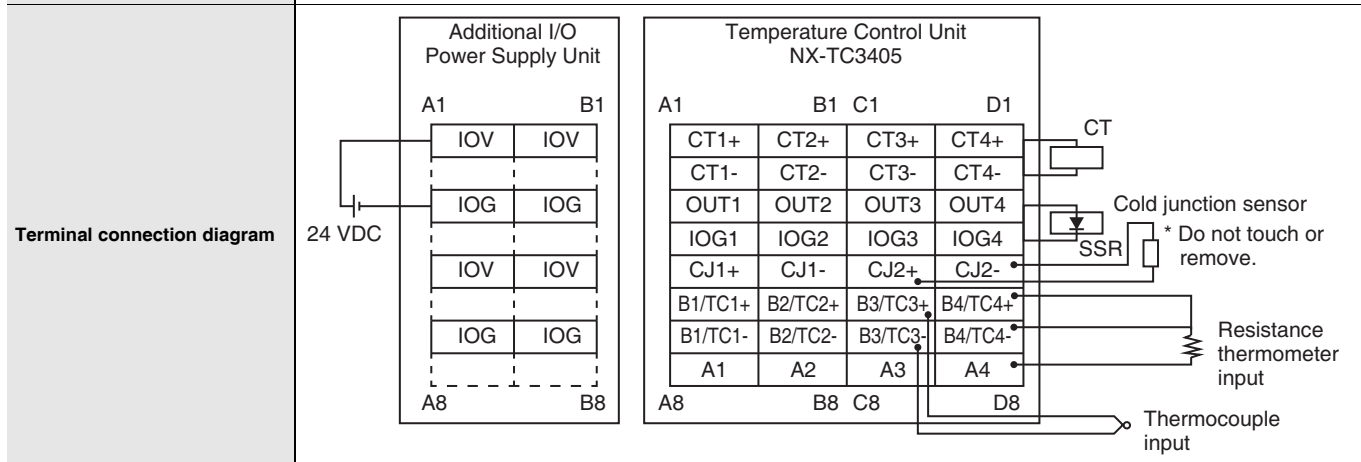

\*1. For the setting ranges and indication ranges of the sensors, refer to the *Input types* on page 24.  
 \*2. For details, refer to the *Reference Accuracy and Temperature Coefficient Table* on page 25.  
 For thermocouple inputs, reference accuracy and cold junction compensation error are guaranteed for a set of a Temperature Control Unit and a terminal block on which a cold junction sensor is mounted.  
 Be sure to use the terminal block and the Temperature Control Unit with the same calibration control number together.  
 A calibration control number is displayed both on the terminal block and the Unit.  
 In order to distinguish left and right terminal blocks, each terminal block has either a letter "L" (left side) or "R" (right side) appended at the end of a calibration control number.  
 Make sure to return the terminal block to which a cold junction sensor is mounted and the Unit together.  
 \*3. For details, refer to *Cold Junction Compensation Error Specifications for Units That Take a Thermocouple Input Type* on page 27.

## NX-TC

## Temperature Control Unit (4-Channel Type) NX-TC3406

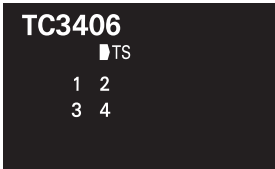
<b>Unit name</b>		Temperature Control Unit (4-Channel Type)	<b>Model</b>	NX-TC3406	
<b>Number of Channels</b>		4 channels	<b>Control type</b>	Standard control	
<b>Number of points per channel</b>		<ul style="list-style-type: none"> <li>Temperature input: 1 point per channel (4 points per unit)</li> <li>CT input: None</li> <li>Control Output: 1 point per channel (4 points per unit)</li> </ul>	<b>External connection terminal</b>	Screwless clamping terminal block (16 terminals x 2)	
<b>I/O refreshing method</b>		Free-Run Refreshing			
<b>Indicators</b>		TS indicator and output indicators			
					
		<b>CT Input section</b>	<b>CT current input range</b>	---	
			<b>Input resistance</b>	---	
			<b>Connectable CTs</b>	---	
			<b>Maximum heater current</b>	---	
			<b>Resolution</b>	---	
			<b>Overall accuracy (25°C)</b>	---	
			<b>Influence of temperature (0 to 55°C)</b>	---	
		<b>Conversion time</b>	---		
<b>Sensor Input section</b>	<b>Temperature sensor *1</b>	<ul style="list-style-type: none"> <li>Thermocouple input: K, J, T, E, L, U, N, R, S, B, C/W, PL II</li> <li>Platinum resistance thermometer input: Pt100 (three-wire), JPt100 (three-wire), Pt1000 (three-wire)</li> </ul>			
		<b>Input conversion range</b>	±20°C of the input range *2		
		<b>Absolute maximum rating</b>	±130 mV		
		<b>Input impedance</b>	20 kΩ min.		
		<b>Resolution</b>	0.1°C max.		
		<b>Reference accuracy</b>	*2		
		<b>Temperature coefficient</b>	*2		
		<b>Cold junction compensation error</b>	±1.2°C *2 *3		
		<b>Input disconnection detection current</b>	Approx. 0.1 uA		
		<b>Input detection current</b>	0.25 mA		
<b>Control Output section</b>	<b>Temperature sensor *1</b>	<ul style="list-style-type: none"> <li>Thermocouple input: 0.1°C/Ω (100 Ω or less per conductor)</li> <li>Platinum resistance thermometer input: 0.06°C/Ω (20 Ω or less per conductor)</li> </ul>			
		<b>Warm-up period</b>	30 minutes		
		<b>Conversion time</b>	50 ms/Unit		
		<b>Control output type and number of control outputs per channel</b>	Voltage output for driving SSR, 1 point per channel		
		<b>Internal I/O common</b>	PNP		
		<b>Control Period</b>	0.1, 0.2, 0.5, 1 to 99s		
		<b>Manipulated variable</b>	-5 to +105%		
		<b>Resolution</b>	---		
		<b>Rated Voltage</b>	24 VDC		
		<b>Operating Load Voltage Range</b>	15 to 28.8 VDC		
<b>Dimensions</b>	<b>Temperature sensor *1</b>	<b>Maximum load current</b>	21 mA/point, 84 mA/Unit		
		<b>Maximum Inrush Current</b>	0.3 A/point max., 10 ms max.		
		<b>Allowable load resistance</b>	---		
		<b>Leakage current</b>	0.1 mA max.		
		<b>Residual voltage</b>	1.5 V max.		
		<b>Load Short-circuit Protection</b>	Provided		
		<b>Output range</b>	---		
		<b>Overall accuracy (25°C)</b>	---		
		<b>Influence of temperature (0 to 55°C)</b>	---		
		<b>Isolation method</b>	<ul style="list-style-type: none"> <li>Between sensor inputs and internal circuitry: Power = Transformer, Signal = Digital isolator</li> <li>Between inputs: Power = Transformer, Signal = Digital isolator</li> <li>Between control output and internal circuit: Photocoupler</li> <li>No isolation between control outputs</li> </ul>		
<b>Insulation resistance</b>	20 MΩ min. between isolated circuits (at 100 VDC)	<b>Dielectric strength</b>	510 VAC between isolated circuits for 1 minute with a leakage current of 5 mA max.		
<b>I/O power supply method</b>	Supplied from the NX bus.	<b>Current capacity of I/O power supply terminals</b>	IOG: 0.1 A max. per terminal		

<b>NX Unit power consumption</b>	<ul style="list-style-type: none"> <li>• Connected to a CPU Unit 1.70 W max.</li> <li>• Connected to Communications Coupler Unit 1.25 W max.</li> </ul>	<b>Current consumption from I/O power supply</b>	20 mA max.
<b>Weight</b>	140 g max.		

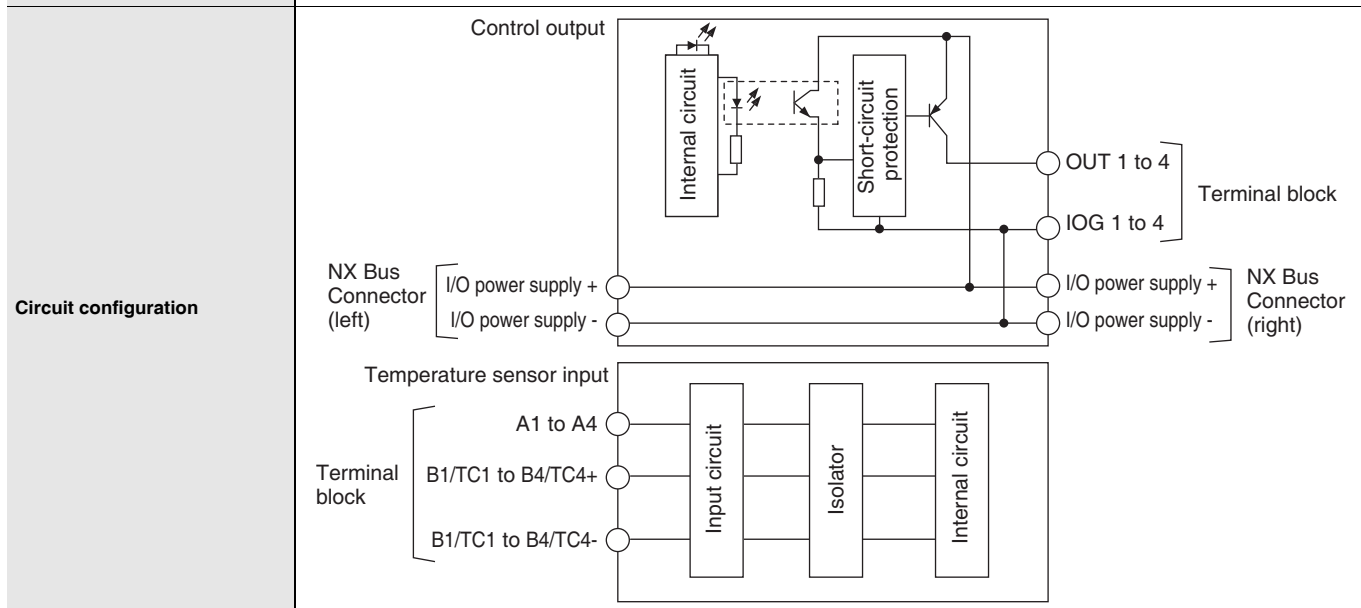

**Installation orientation and restrictions**

Mounting orientation:

- Connect to CPU unit
- Front mounting orientation is possible
- Connect to communication coupler unit
- Six orientations are possible

Limitation:  
The cold junction compensation error is limited by the mounting orientation and the type or power consumption of the adjacent unit. For details, refer to *Cold Junction Compensation Error Specifications for Units That Take a Thermocouple Input Type* on page 27.

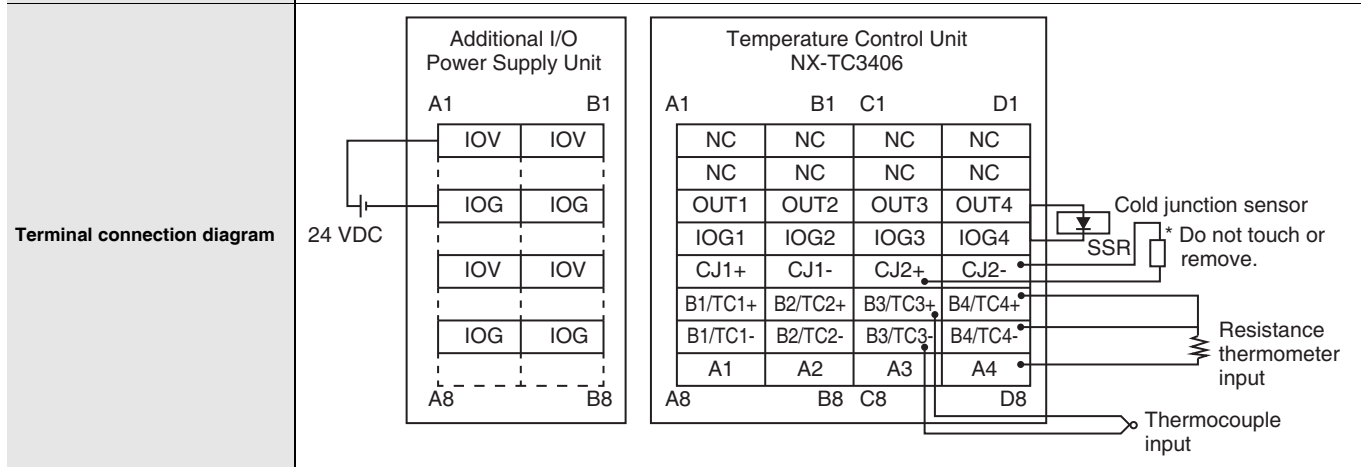

- \*1. For the setting ranges and indication ranges of the sensors, refer to the *Input types* on page 24.
- \*2. For details, refer to the *Reference Accuracy and Temperature Coefficient Table* on page 25.  
For thermocouple inputs, reference accuracy and cold junction compensation error are guaranteed for a set of a Temperature Control Unit and a terminal block on which a cold junction sensor is mounted.  
Be sure to use the terminal block and the Temperature Control Unit with the same calibration control number together.  
A calibration control number is displayed both on the terminal block and the Unit.  
In order to distinguish left and right terminal blocks, each terminal block has either a letter "L" (left side) or "R" (right side) appended at the end of a calibration control number.  
Make sure to return the terminal block to which a cold junction sensor is mounted and the Unit together.
- \*3. For details, refer to *Cold Junction Compensation Error Specifications for Units That Take a Thermocouple Input Type* on page 27.

## NX-TC

## Temperature Control Unit (4-Channel Type) NX-TC3407

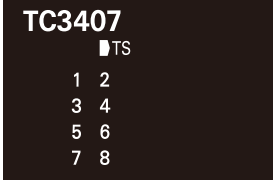
<b>Unit name</b>		Temperature Control Unit (4-Channel Type)	<b>Model</b>	NX-TC3407	
<b>Number of Channels</b>		4 channels	<b>control type</b>	heating and cooling control	
<b>Number of points per channel</b>		<ul style="list-style-type: none"> <li>Temperature input: 1 point per channel (4 points per unit)</li> <li>CT input: None</li> <li>Control Output: 2 point per channel (8 points per unit)</li> </ul>	<b>External connection terminal</b>	Screwless clamping terminal block (16 terminals x 2)	
<b>I/O refreshing method</b>		Free-Run Refreshing			
<b>Indicators</b>		TS indicator and output indicators			
					
		<b>CT Input section</b>	<b>CT current input range</b>	---	
			<b>Input resistance</b>	---	
			<b>Connectable CTs</b>	---	
			<b>Maximum heater current</b>	---	
			<b>Resolution</b>	---	
			<b>Overall accuracy (25°C)</b>	---	
			<b>Influence of temperature (0 to 55°C)</b>	---	
			<b>Conversion time</b>	---	
<b>Control Output section</b>	<b>Control output type and number of control outputs per channel</b>	Voltage output for driving SSR, 2 point per channel			
	<b>Internal I/O common</b>	PNP			
	<b>Control Period</b>	0.1, 0.2, 0.5, 1 to 99s			
	<b>Manipulated variable</b>	<ul style="list-style-type: none"> <li>Heating: 0 to +105%</li> <li>Cooling: 0 to +105%</li> </ul>			
	<b>Resolution</b>	---			
	<b>Rated Voltage</b>	24 VDC			
	<b>Operating Load Voltage Range</b>	15 to 28.8 VDC			
	<b>Maximum load current</b>	21 mA/point, 168 mA/Unit			
	<b>Maximum Inrush Current</b>	0.3 A/point max., 10 ms max.			
	<b>Allowable load resistance</b>	---			
<b>Sensor Input section</b>	<b>Temperature sensor *1</b>	<ul style="list-style-type: none"> <li>Thermocouple input: K, J, T, E, L, U, N, R, S, B, C/W, PL II</li> <li>Platinum resistance thermometer input: Pt100 (three-wire), JPt100 (three-wire), Pt1000 (three-wire)</li> </ul>			
	<b>Input conversion range</b>	±20°C of the input range *2			
	<b>Absolute maximum rating</b>	±130 mV			
	<b>Input impedance</b>	20 kΩ min.			
	<b>Resolution</b>	0.1°C max.			
	<b>Reference accuracy</b>	*2			
	<b>Temperature coefficient</b>	*2			
	<b>Cold junction compensation error</b>	±1.2°C *2 *3			
	<b>Input disconnection detection current</b>	Approx. 0.1 uA			
	<b>Input detection current</b>	0.25 mA			
<b>Dimensions</b>	<b>Effect of conductor resistance</b>	<ul style="list-style-type: none"> <li>Thermocouple input: 0.1°C/Ω (100 Ω or less per conductor)</li> <li>Platinum resistance thermometer input: 0.06°C/Ω (20 Ω or less per conductor)</li> </ul>			
	<b>Warm-up period</b>	30 minutes			
	<b>Conversion time</b>	50 ms/Unit			
	<b>Isolation method</b>	<ul style="list-style-type: none"> <li>Between sensor inputs and internal circuitry: Power = Transformer, Signal = Digital isolator</li> <li>Between inputs: Power = Transformer, Signal = Digital isolator</li> <li>Between control output and internal circuit: Photocoupler</li> <li>No isolation between control outputs</li> </ul>			
	<b>Insulation resistance</b>	20 MΩ min. between isolated circuits (at 100 VDC)			
	<b>Dielectric strength</b>	510 VAC between isolated circuits for 1 minute with a leakage current of 5 mA max.			
	<b>I/O power supply method</b>	Supplied from the NX bus.			
	<b>Current capacity of I/O power supply terminals</b>	IOG: 0.1 A max. per terminal			
	<b>Output range</b>	---			
	<b>Overall accuracy (25°C)</b>	---			
<b>Influence of temperature (0 to 55°C)</b>	---				

<b>NX Unit power consumption</b>	<ul style="list-style-type: none"> <li>• Connected to a CPU Unit 1.75 W max.</li> <li>• Connected to Communications Coupler Unit 1.30 W max.</li> </ul>	<b>Current consumption from I/O power supply</b>	20 mA max.
<b>Weight</b>	140 g max.		

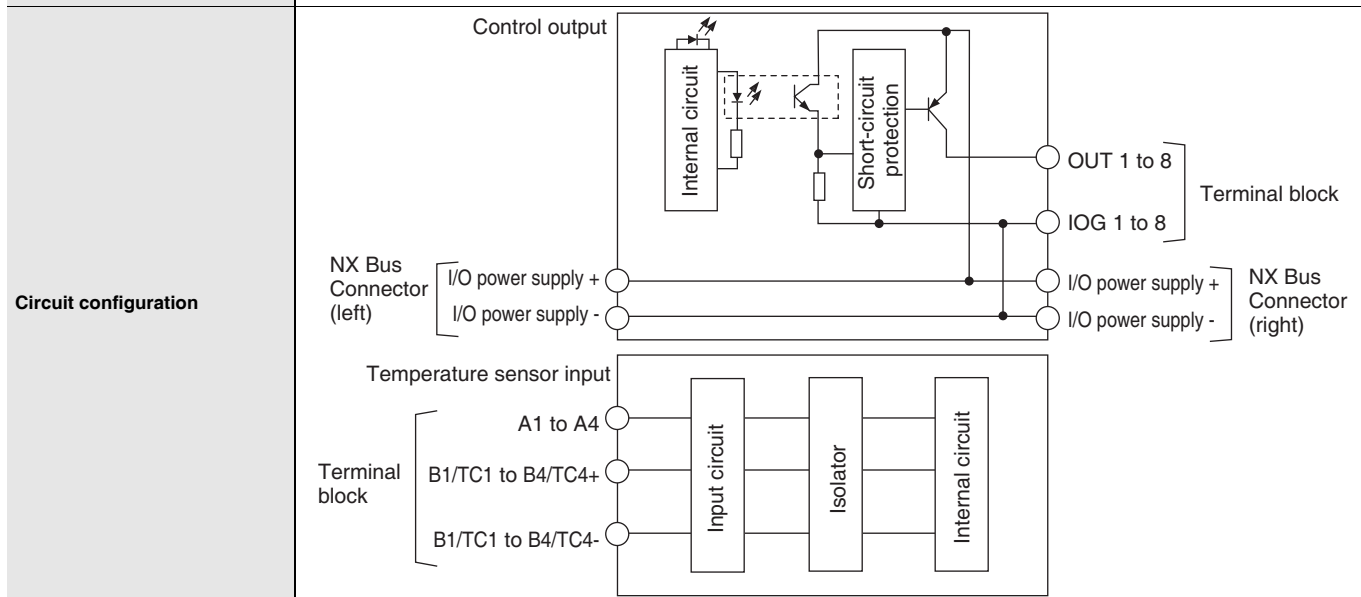

**Installation orientation and restrictions**

Mounting orientation:

- Connect to CPU unit
- Front mounting orientation is possible
- Connect to communication coupler unit
- Six orientations are possible

Limitation:  
The cold junction compensation error is limited by the mounting orientation and the type or power consumption of the adjacent unit. For details, refer to *Cold Junction Compensation Error Specifications for Units That Take a Thermocouple Input Type* on page 27.

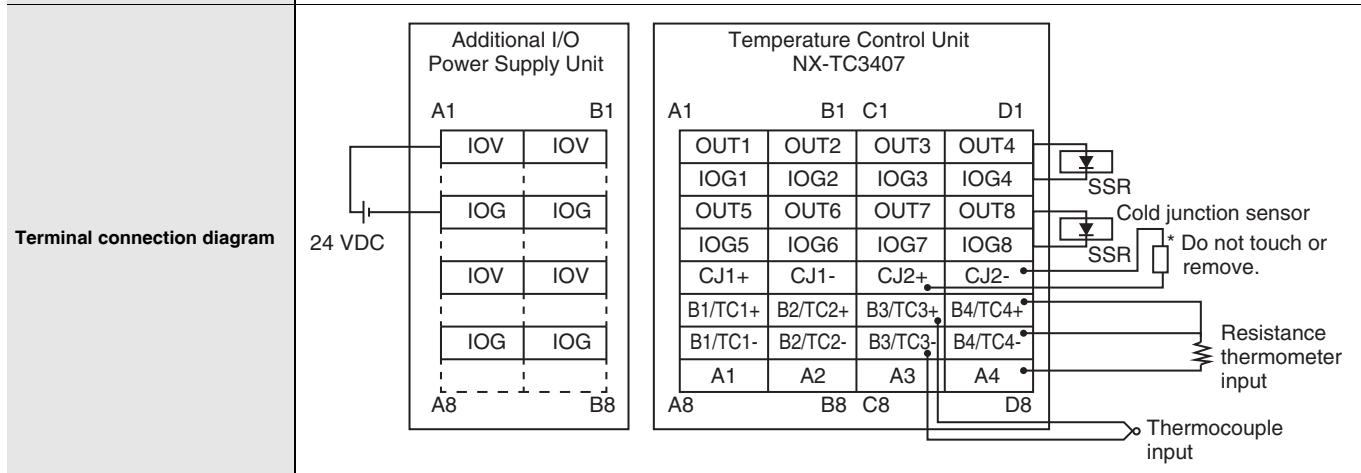

- \*1. For the setting ranges and indication ranges of the sensors, refer to the *Input types* on page 24.
- \*2. For details, refer to the *Reference Accuracy and Temperature Coefficient Table* on page 25.  
For thermocouple inputs, reference accuracy and cold junction compensation error are guaranteed for a set of a Temperature Control Unit and a terminal block on which a cold junction sensor is mounted.  
Be sure to use the terminal block and the Temperature Control Unit with the same calibration control number together.  
A calibration control number is displayed both on the terminal block and the Unit.  
In order to distinguish left and right terminal blocks, each terminal block has either a letter "L" (left side) or "R" (right side) appended at the end of a calibration control number.  
Make sure to return the terminal block to which a cold junction sensor is mounted and the Unit together.
- \*3. For details, refer to *Cold Junction Compensation Error Specifications for Units That Take a Thermocouple Input Type* on page 27.

## NX-TC

## Temperature Control Unit (4-Channel Type) NX-TC3408

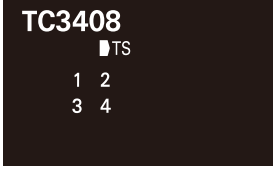
<b>Unit name</b>		Temperature Control Unit (4-Channel Type)	<b>Model</b>	NX-TC3408	
<b>Number of Channels</b>		4 channels	<b>Control type</b>	Standard control	
<b>Number of points per channel</b>		<ul style="list-style-type: none"> <li>Temperature input: 1 point per channel (4 points per unit)</li> <li>CT input: None</li> <li>Control Output: 1 point per channel (4 points per unit)</li> </ul>	<b>External connection terminal</b>	Screwless clamping terminal block (16 terminals x 2)	
<b>I/O refreshing method</b>		Free-Run Refreshing			
<b>Indicators</b>		TS indicator and output indicators			
					
		<b>CT Input section</b>	<b>CT current input range</b>	---	
			<b>Input resistance</b>	---	
			<b>Connectable CTs</b>	---	
			<b>Maximum heater current</b>	---	
			<b>Resolution</b>	---	
			<b>Overall accuracy (25°C)</b>	---	
<b>Influence of temperature (0 to 55°C)</b>	---				
<b>Conversion time</b>	---				
<b>Sensor Input section</b>		<ul style="list-style-type: none"> <li>Thermocouple input: K, J, T, E, L, U, N, R, S, B, C/W, PL II</li> <li>Platinum resistance thermometer input: Pt100 (three-wire), JPt100 (three-wire), Pt1000 (three-wire)</li> </ul>	<b>Control output type and number of control outputs per channel</b>	Linear current output, one output per channel	
			<b>Internal I/O common</b>	---	
			<b>Control Period</b>	---	
			<b>Manipulated variable</b>	-5 to +105%	
			<b>Resolution</b>	1/10,000	
			<b>Rated Voltage</b>	24 VDC	
			<b>Operating Load Voltage Range</b>	15 to 28.8 VDC	
			<b>Maximum load current</b>	---	
			<b>Maximum Inrush Current</b>	---	
			<b>Allowable load resistance</b>	350 Ω or less, or greater than 350 Ω but no more than 600 Ω *3	
<b>Leakage current</b>	---				
<b>Residual voltage</b>	---				
<b>Load Short-circuit Protection</b>	---				
<b>Output range</b>	0 to 20 mA, 4 to 20 mA				
<b>Overall accuracy (25°C)</b>	±0.3% of full scale, but 1% of full scale at 0 to 4 mA of 0 to 20 mA range				
<b>Influence of temperature (0 to 55°C)</b>	±0.3% (full scale)				
<b>Dimensions</b>		24 mm (W) ×100 mm (H) ×71 mm (D)	<b>Isolation method</b>	<ul style="list-style-type: none"> <li>Between sensor inputs and internal circuitry: Power = Transformer, Signal = Digital isolator</li> <li>Between inputs: Power = Transformer, Signal = Digital isolator</li> <li>Between control output and internal circuit: Photocoupler</li> <li>No isolation between control outputs</li> </ul>	
<b>Insulation resistance</b>		20 MΩ min. between isolated circuits (at 100 VDC)	<b>Dielectric strength</b>	510 VAC between isolated circuits for 1 minute with a leakage current of 5 mA max.	
<b>I/O power supply method</b>		Supplied from the NX bus.	<b>Current capacity of I/O power supply terminals</b>	I/O: 0.1 A max. per terminal	

<b>NX Unit power consumption</b>	<ul style="list-style-type: none"> <li>• Connected to a CPU Unit 1.65 W max.</li> <li>• Connected to Communications Coupler Unit 1.25 W max.</li> </ul>	<b>Current consumption from I/O power supply</b>	30 mA max.
----------------------------------	---	--	------------

<b>Weight</b>	140 g max.
---------------	------------

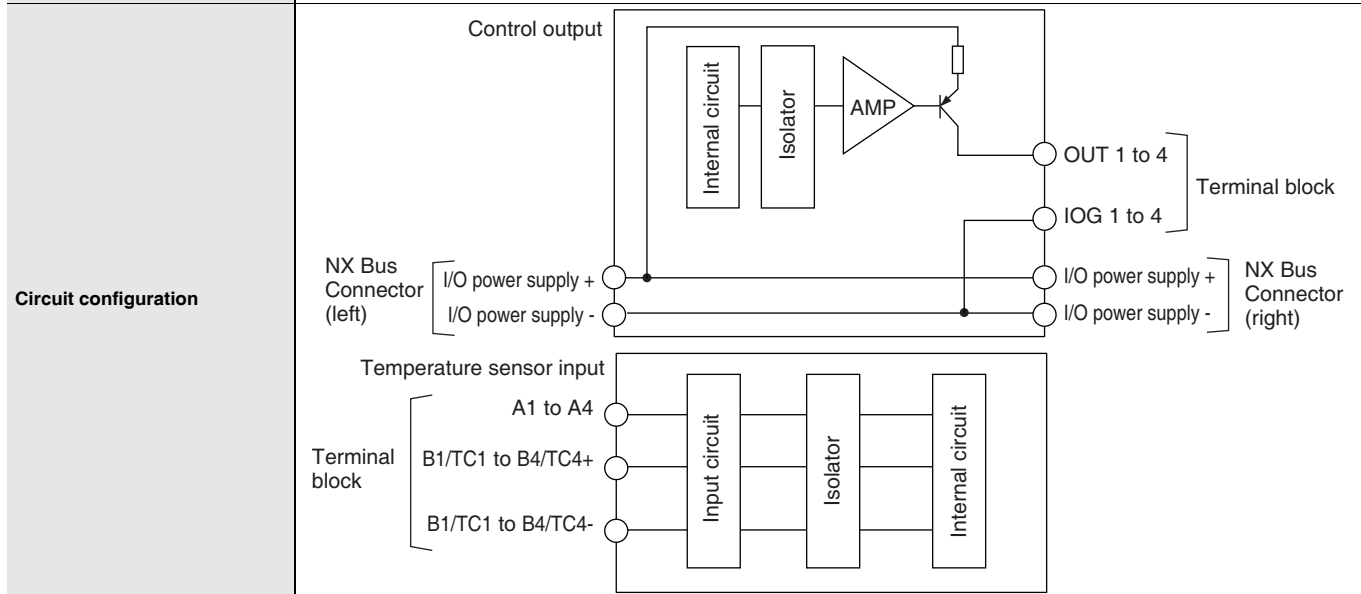

**Installation orientation and restrictions**

Mounting orientation:

- Connect to CPU unit  
Front mounting orientation is possible
- Connect to communication coupler unit  
Six orientations are possible

Limitation:  
 The cold junction compensation error is limited by the mounting orientation and the type or power consumption of the adjacent unit. For details, refer to *Cold Junction Compensation Error Specifications for Units That Take a Thermocouple Input Type* on page 27.

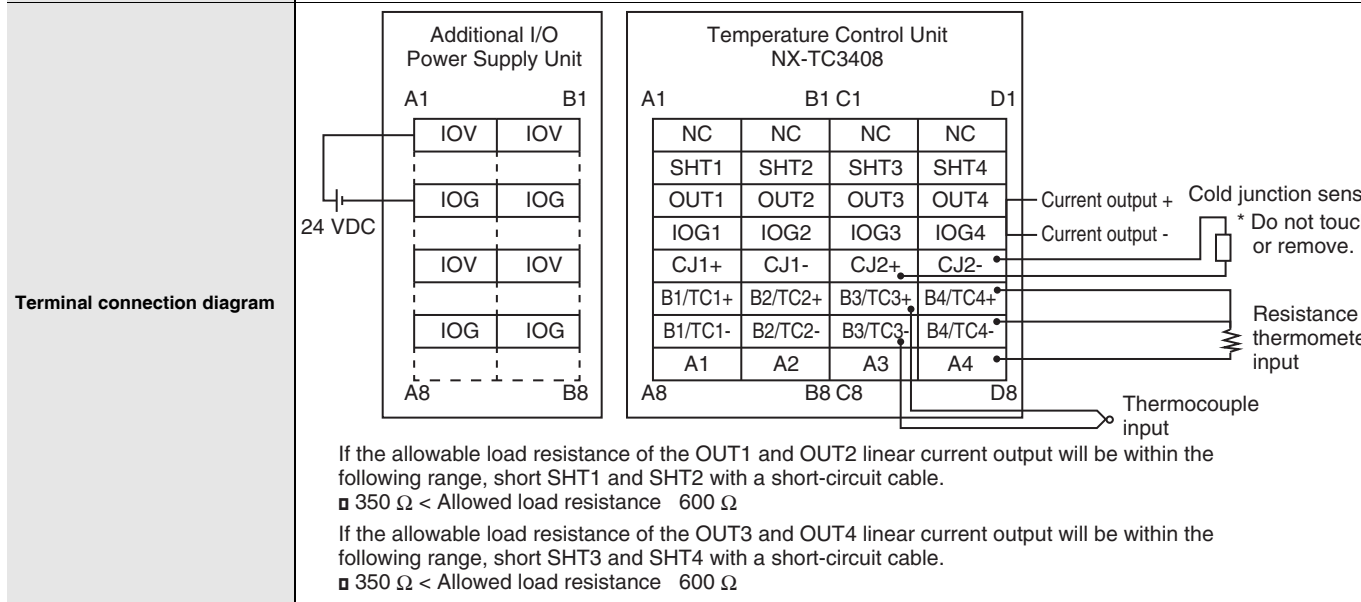

- \*1. For the setting ranges and indication ranges of the sensors, refer to the *Input types* on page 24.
- \*2. For details, refer to the *Reference Accuracy and Temperature Coefficient Table* on page 25.  
 For thermocouple inputs, reference accuracy and cold junction compensation error are guaranteed for a set of a Temperature Control Unit and a terminal block on which a cold junction sensor is mounted.  
 Be sure to use the terminal block and the Temperature Control Unit with the same calibration control number together.  
 A calibration control number is displayed both on the terminal block and the Unit.  
 In order to distinguish left and right terminal blocks, each terminal block has either a letter "L" (left side) or "R" (right side) appended at the end of a calibration control number.  
 Make sure to return the terminal block to which a cold junction sensor is mounted and the Unit together.
- \*3. To use an allowable load resistance greater than 350 Ω but not exceeding 600 Ω, either SHT1 and SHT2, or SHT3 and SHT4 must be shorted with a shorting cable.  
 For details, refer to the *NX-series Temperature Control Units User's Manual* (Cat. No. W523).
- \*4. For details, refer to *Cold Junction Compensation Error Specifications for Units That Take a Thermocouple Input Type* on page 27.

# NX-TC

## Input types

The settings are shown in the following table.

Setting name*1	Display of support software	Description	Default	Setting range	Unit	Change application timing
Ch□ input type	Ch□ Input Type	Sets the input type of sensors connected to temperature input.	5: K -200 to 1300°C	*2	No	After unit restart

\*1. □ represents the channel number.

\*2. The setting ranges are shown below. However, the 21, 22, and 23 input types can be used with unit versions 1.2 and later.

Set values	Input types		Input indication range	Remarks	
	Sensor	Input setting range			
0	Pt100	-200 to 850°C/-300 to 1500°F	-220 to 870°C/-340 to 1540°F	Resistance thermometer	
1	Pt100	-199.9 to 500.0°C/-199.9 to 900.0°F	-219.9 to 520.0°C/-239.9 to 940.0°F		
2	Pt100	-0.0 to 100.0°C/0.0 to 210.0°F	-20.0 to 120.0°C/-40.0 to 250.0°F		
3	JPt100	-199.9 to 500.0°C/-199.9 to 900.0°F	-219.9 to 520.0°C/-239.9 to 940.0°F		
4	JPt100	-0.0 to 100.0°C/0.0 to 210.0°F	-20.0 to 120.0°C/-40.0 to 250.0°F		
5	K	-200 to 1300°C/-300 to 2300°F	-220 to 1320°C/-340 to 2340°F		Thermocouple
6	K	-20.0 to 500.0°C/0.0 to 900.0°F	-40.0 to 520.0°C/-40.0 to 940.0°F		
7	J	-100 to 850°C/-100.0 to 1500°F	-120 to 870°C/-140 to 1540°F		
8	J	-20.0 to 400.0°C/0.0 to 750.0°F	-40.0 to 420.0°C/-40.0 to 790.0°F		
9	T	-200 to 400°C/-300 to 700°F	-220 to 420°C/-340 to 740°F		
10	T	-199.9 to 400.0°C/-199.9 to 700.0°F	-219.9 to 420.0°C/-239.9 to 740°F		
11	E	-200 to 600°C/-300 to 1100°F	-220 to 620°C/-340 to 1140°F		
12	L	-100 to 850°C/-100 to 1500°F	-120 to 870°C/-140 to 1540°F		
13	U	-200 to 400°C/-300 to 700°F	-220 to 420°C/-340 to 740°F		
14	U	-199.9 to 400.0°C/-199.9 to 700.0°F	-219.9 to 420.0°C/-239.9 to 740°F		
15	N	-200 to 1300°C/-300 to 2300°F	-220 to 1320°C/-340 to 2340°F		
16	R	0 to 1700°C/0 to 3000°F	-20 to 1720°C/-40 to 3040°F		
17	S	0 to 1700°C/0 to 3000°F	-20 to 1720°C/-40 to 3040°F		
18	B	0 to 1800°C/0 to 3200°F	-20 to 1820°C/-40 to 3240°F		
19	C/W	0 to 2300°C/0 to 3200°F	-20 to 2320°C/-40 to 3240°F		
20	PLII	0 to 1300°C/0 to 2300°F	-20 to 1320°C/-40 to 2340°F		
21	Pt1000	-200 to 850°C/-300 to 1500°F	-220 to 870°C/-340 to 1540°F	Resistance thermometer	
22	Pt1000	-199.9 to 500.0°C/-199.9 to 900.0°F	-219.9 to 520.0°C/-239.9 to 940.0°F		
23	Pt1000	0.0 to 100.0°C/0.0 to 210.0°F	-20.0 to 120.0°C/-40.0 to 250.0°F		

## Reference Accuracy and Temperature Coefficient Table

Reference accuracies and temperature coefficients are shown below by input type and measurement temperature.

To convert the temperature unit from Celsius to Fahrenheit, use the following equation.

Fahrenheit temperature (°F) = Celsius temperature (°C) x 1.8 + 32

Set values	Input type		Measurement temperature (°C)	Reference accuracy °C (%) *2	Temperature coefficient °C/°C *3 (ppm/°C *4)	
	Sensor	Temperature range (°C) *1				
0	Pt100	-200 to 850	-200 to 300	±1.0 (±0.1%)	±0.1 (±100 ppm/°C)	
			300 to 700	±2.0 (±0.2%)	±0.2 (±200 ppm/°C)	
			700 to 850	±2.5 (±0.25%)	±0.25 (±250 ppm/°C)	
1	Pt100	-199.9 to 500.0	-199.9 to 300.0	±0.8 (±0.12%)	±0.1 (±150 ppm/°C)	
			300.0 to 500.0	±0.8 (±0.12%)	±0.2 (±300 ppm/°C)	
2	Pt100	0.0 to 100.0	0.0 to 100.0	±0.8 (±0.8%)	±0.1 (±1000 ppm/°C)	
3	JPt100	-199.9 to 500.0	-199.9 to 300.0	±0.8 (±0.12%)	±0.1 (±150 ppm/°C)	
			300.0 to 500.0	±0.8 (±0.12%)	±0.2 (±300 ppm/°C)	
4	JPt100	0.0 to 100.0	0.0 to 100.0	±0.8 (±0.8%)	±0.1 (±1000 ppm/°C)	
5	K	-200 to 1300	-200 to -100	±1.5 (±0.1%)	±0.15 (±100 ppm/°C)	
			-100 to 400		±0.30 (±200 ppm/°C)	
			400 to 1300		±0.38 (±250 ppm/°C)	
6	K	-20.0 to 500.0	-20.0 to 400.0	±1.0 (±0.2%)	±0.30 (±600 ppm/°C)	
			400.0 to 500.0		±0.38 (±760 ppm/°C)	
7	J	-100 to 850	-100 to 400	±1.4 (±0.15%)	±0.14 (±150 ppm/°C)	
			400 to 850	±1.2 (±0.13%)	±0.28 (±300 ppm/°C)	
8	J	-20.0 to 400.0	-20.0 to 400.0	±1.0 (±0.24%)	±0.14 (±350 ppm/°C)	
9	T	-200 to 400	-200 to -100	±1.2 (±0.2%)	±0.30 (±500 ppm/°C)	
			-100 to 400		±0.12 (±200 ppm/°C)	
10	T	-199.9 to 400.0	-199.9 to -100.0	±1.2 (±0.2%)	±0.30 (±500 ppm/°C)	
			-100.0 to 400.0		±0.12 (±200 ppm/°C)	
11	E	-200 to 600	-200 to 400	±1.2 (±0.15%)	±0.12 (±150 ppm/°C)	
			400 to 600	±2.0 (±0.25%)	±0.24 (±300 ppm/°C)	
12	L	-100 to 850	-100 to 300	±1.1 (±0.12%)	±0.11 (±120 ppm/°C)	
			300 to 700	±2.2 (±0.24%)	±0.22 (±240 ppm/°C)	
			700 to 850		±0.28 (±300 ppm/°C)	
13	U	-200 to 400	-200 to 400	±1.2 (±0.2%)	±0.12 (±200 ppm/°C)	
14	U	-199.9 to 400.0	-199.9 to 400.0	±1.2 (±0.2%)	±0.12 (±200 ppm/°C)	
15	N	-200 to 1300	-200 to 400	±1.5 (±0.1%)	±0.30 (±200 ppm/°C)	
			400 to 1000		±0.38 (±250 ppm/°C)	
			1000 to 1300			
16	R	0 to 1700	0 to 500	±1.75 (±0.11%)	±0.44 (±260 ppm/°C)	
			500 to 1200	±2.5 (±0.15%)		
			1200 to 1700			
17	S	0 to 1700	0 to 1700	±2.5 (±0.15%)	±0.44 (±260 ppm/°C)	
			0 to 1800	0 to 400	Reference accuracy cannot be guaranteed	Reference accuracy cannot be guaranteed
				400 to 1200	±3.6 (±0.2%)	±0.45 (±250 ppm/°C)
18	B	0 to 1800	1200 to 1800	±5.0 (±0.28%)	±0.54 (±300 ppm/°C)	
			0 to 2300	0 to 300	±1.15 (±0.05%)	±0.46 (±200 ppm/°C)
				300 to 800	±2.3 (±0.1%)	
800 to 1500	±3.0 (±0.13%)					
1500 to 2300		±0.691 (±300 ppm/°C)				
19	C/W	0 to 2300	0 to 400	±1.3 (±0.1%)	±0.23 (±200 ppm/°C)	
			400 to 800	±2.0 (±0.15%)	±0.39 (±300 ppm/°C)	
			800 to 1300		±0.65 (±500 ppm/°C)	
20	PL II	0 to 1300	-200 to 300	±1.0 (±0.1%)	±0.1 (±100 ppm/°C)	
			300 to 700	±2.0 (±0.2%)	±0.2 (±200 ppm/°C)	
			700 to 850	±2.5 (±0.25%)	±0.25 (±250 ppm/°C)	
21	Pt1000	-200 to 850	-199.9 to 300.0	±0.8 (±0.12%)	±0.1 (±150 ppm/°C)	
			300.0 to 500.0		±0.2 (±300 ppm/°C)	
22	Pt1000	0.0 to 100.0	0.0 to 100.0	±0.8 (±0.8%)	±0.1 (±1000 ppm/°C)	
23	Pt1000	0.0 to 100.0	0.0 to 100.0	±0.8 (±0.8%)	±0.1 (±1000 ppm/°C)	

\*1. The decimal point position of the various input types is "no decimal point" or "decimal point 1 digit". When calculating measured value error, round up calculation results in accordance with the decimal point position of the temperature range.

# NX-TC

\*2. The overall accuracy of the Temperature Control Unit is guaranteed for a set consisting of a cold junction sensor that is mounted on the terminal block and a Temperature Control Unit. Be sure to use the terminal block and Temperature Control Unit with the same calibration control number together. For the 24mm width model, also be sure the left and right terminal blocks are correctly attached.

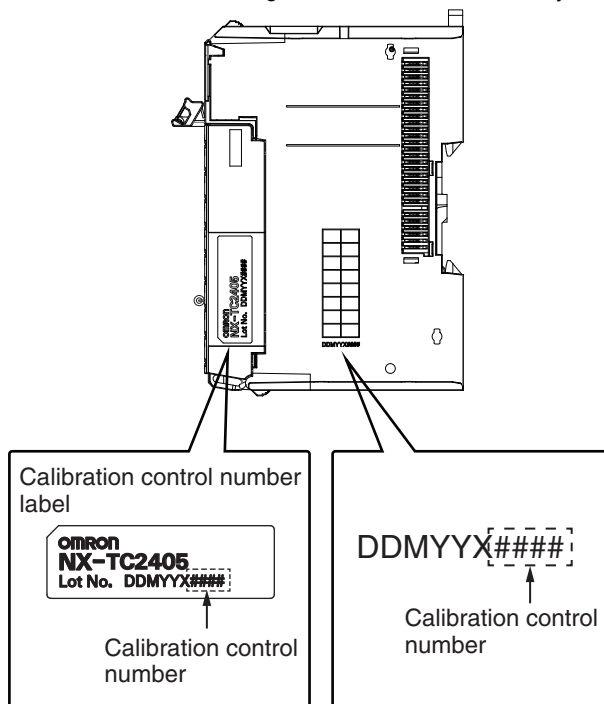

\*3. An error for a measured value when the ambient temperature changes by 1°C. The following formula is used to calculate the error of the measured value for thermocouple inputs.. Overall accuracy = Reference accuracy + Temperature characteristic x Change in the ambient temperature + Cold junction compensation error For resistance thermometer inputs, there is no cold junction compensation error. (Calculation example)

- Conditions

Item	Description
Ambient temperature	30°C
Measured value	100°C
Thermocouple	K: -200 to 1300°C

- The characteristic values are formulated from the datasheet or reference accuracy and temperature coefficient table under the above conditions

Item	Description
Reference accuracy	-100 to 400°C: ±1.5°C
Temperature coefficient	-100 to 400°C: ±0.30°C/°C
Change in the ambient temperature	25°C -> 30°C 5 deg
Cold junction compensation error	±1.2°C

Therefore,

$$\begin{aligned} \text{Overall accuracy} &= \text{Reference accuracy} + \text{Temperature characteristic} \times \text{Change in the ambient temperature} + \\ &\text{Cold junction compensation error} \\ &= \pm 1.5^\circ\text{C} + (\pm 0.30^\circ\text{C}/^\circ\text{C}) \times 5 \text{ deg} + \pm 1.2^\circ\text{C} \\ &= \pm 4.2^\circ\text{C} \end{aligned}$$

-200 to 1300°C without decimal point. the calculation result is round up after the decimal point. Then the overall accuracy is ±5°C.

\*4. The ppm value is for the full scale of the temperature range.

## Cold Junction Compensation Error Specifications for Units That Take a Thermocouple Input Type

This section describes the cold junction compensation errors for thermocouple inputs, which differ by installation orientation of this Unit, type of adjacent Units, and current consumed by the adjacent Units.

### When the Adjacent Units are Temperature Control Units

This section describes the cold junction compensation errors when the adjacent Units are Temperature Control Units. The error differs by installation orientation.

#### (a) For upright installation

The cold junction compensation error is  $\pm 1.2^{\circ}\text{C}$ .

However, there are exceptions depending on the input type and temperature. Those conditions and the cold junction compensation error are as in the table below.

Input type and temperature range	Cold junction compensation error
T below $-90^{\circ}\text{C}$	$\pm 3.0^{\circ}\text{C}$
J, E, K and N below $-100^{\circ}\text{C}$	
U, L and PLII	
R and S below $200^{\circ}\text{C}$	
B below $400^{\circ}\text{C}$	Not guaranteed
C/W	$\pm 3.0^{\circ}\text{C}$

#### (b) For other than upright installation

The cold junction compensation error is  $\pm 4.0^{\circ}\text{C}$ .

However, there are exceptions depending on the input type and temperature. Those conditions and the cold junction compensation error are as in the table below.

Input type and temperature range	Cold junction compensation error
T below $-90^{\circ}\text{C}$	$\pm 7.0^{\circ}\text{C}$
J, E, K and N below $-100^{\circ}\text{C}$	
U, L and PLII	
R and S below $200^{\circ}\text{C}$	
B below $400^{\circ}\text{C}$	Not guaranteed
C/W	$\pm 9.0^{\circ}\text{C}$

### When the Adjacent Units are not Temperature Control Units

This section describes the cold junction compensation errors when the adjacent Units are not Temperature Control Units. The error differs by the installation orientation and power consumption by the adjacent Units.

#### (a) For upright installation, when the power consumption is 1.5 W or less for both the left and right adjacent Units

The cold junction compensation error is  $\pm 1.2^{\circ}\text{C}$ .

However, there are exceptions depending on the input type and temperature. Those conditions and the cold junction compensation error are as in the table below.

Input type and temperature range	Cold junction compensation error
T below $-90^{\circ}\text{C}$	$\pm 3.0^{\circ}\text{C}$
J, E, K and N below $-100^{\circ}\text{C}$	
U, L and PLII	
R and S below $200^{\circ}\text{C}$	
B below $400^{\circ}\text{C}$	Not guaranteed
C/W	$\pm 3.0^{\circ}\text{C}$

#### (b) When the power consumption of either the left or the right adjacent Unit is more than 1.5 W but less than 3.9 W.

**Or for any installation other than upright, when the power consumption of both the left and right adjacent Units is less than 3.9 W**

The cold junction compensation error is  $\pm 4.0^{\circ}\text{C}$ .

However, there are exceptions depending on the input type and temperature. Those conditions and the cold junction compensation error are as in the table below.

Input type and temperature range	Cold junction compensation error
T below $-90^{\circ}\text{C}$	$\pm 7.0^{\circ}\text{C}$
J, E, K and N below $-100^{\circ}\text{C}$	
U, L and PLII	
R and S below $200^{\circ}\text{C}$	
B below $400^{\circ}\text{C}$	Not guaranteed
C/W	$\pm 9.0^{\circ}\text{C}$

#### (c) When the power consumption exceeds 3.9 W for either the left or right adjacent Unit

Do not use the above condition (c) because the cold junction compensation error is not guaranteed in this condition.

#### (d) The power consumption of adjacent Units

The power consumption of adjacent Units is the total of the following values.

- The power consumption of the NX Unit power supply and I/O power supply for the NX Units adjacent to the Temperature Input Unit. If the adjacent Unit is an Input Unit, it is the total power consumption according to the input current.

# NX-TC

## Version Information

### Connected to a CPU Unit

Refer to the user's manual for the CPU Unit for details on the CPU Units to which NX Units can be connected.

NX Unit		Corresponding version *1	
Model	Unit Version	CPU Unit	Sysmac Studio
NX-TC2405	Ver.1.0	Ver.1.13	Ver.1.21
	Ver.1.1		Ver.1.22
	Ver.1.2		Ver.1.30
	Ver.1.3		Ver.1.40
NX-TC2406	Ver.1.0		Ver.1.21
	Ver.1.1		Ver.1.22
	Ver.1.2		Ver.1.30
	Ver.1.3		Ver.1.40
NX-TC2407	Ver.1.0		Ver.1.21
	Ver.1.1		Ver.1.22
	Ver.1.2		Ver.1.30
	Ver.1.3		Ver.1.40
NX-TC2408	Ver.1.0		Ver.1.21
	Ver.1.1		Ver.1.22
	Ver.1.2		Ver.1.30
	Ver.1.3		Ver.1.40
NX-TC3405	Ver.1.0	Ver.1.21	
	Ver.1.1	Ver.1.22	
	Ver.1.2	Ver.1.30	
	Ver.1.3	Ver.1.40	
NX-TC3406	Ver.1.0	Ver.1.21	
	Ver.1.1	Ver.1.22	
	Ver.1.2	Ver.1.30	
	Ver.1.3	Ver.1.40	
NX-TC3407	Ver.1.0	Ver.1.21	
	Ver.1.1	Ver.1.22	
	Ver.1.2	Ver.1.30	
	Ver.1.3	Ver.1.40	
NX-TC3408	Ver.1.0	Ver.1.21	
	Ver.1.1	Ver.1.22	
	Ver.1.2	Ver.1.30	
	Ver.1.3	Ver.1.40	

\*1. Some Units do not have all of the versions given in the above table. If a Unit does not have the specified version, support is provided by the oldest available version after the specified version. Refer to the user's manuals for the specific Units for the relation between models and versions.

## Connected to a Communications EtherCAT Coupler Unit

NX Unit		Corresponding version *1				
Model	Unit Version	EtherCAT Coupler Unit	CPU Unit or Industrial PC	Sysmac Studio		
NX-TC2405	Ver.1.0	Ver.1.0 *2	Ver. 1.05	Ver.1.21		
	Ver.1.1			Ver.1.22		
	Ver.1.2			Ver.1.30		
	Ver.1.3			Ver.1.40		
NX-TC2406	Ver.1.0					Ver.1.21
	Ver.1.1					Ver.1.22
	Ver.1.2					Ver.1.30
	Ver.1.3					Ver.1.40
NX-TC2407	Ver.1.0					Ver.1.21
	Ver.1.1					Ver.1.22
	Ver.1.2					Ver.1.30
	Ver.1.3					Ver.1.40
NX-TC2408	Ver.1.0					Ver.1.21
	Ver.1.1					Ver.1.22
	Ver.1.2					Ver.1.30
	Ver.1.3					Ver.1.40
NX-TC3405	Ver.1.0					Ver.1.21
	Ver.1.1					Ver.1.22
	Ver.1.2					Ver.1.30
	Ver.1.3					Ver.1.40
NX-TC3406	Ver.1.0			Ver.1.21		
	Ver.1.1			Ver.1.22		
	Ver.1.2			Ver.1.30		
	Ver.1.3			Ver.1.40		
NX-TC3407	Ver.1.0			Ver.1.21		
	Ver.1.1			Ver.1.22		
	Ver.1.2			Ver.1.30		
	Ver.1.3			Ver.1.40		
NX-TC3408	Ver.1.0			Ver.1.21		
	Ver.1.1			Ver.1.22		
	Ver.1.2			Ver.1.30		
	Ver.1.3			Ver.1.40		

\*1. Some Units do not have all of the versions given in the above table. If a Unit does not have the specified version, support is provided by the oldest available version after the specified version. Refer to the user's manuals for the specific Units for the relation between models and versions.

\*2. When you connect the Unit to a master of other manufacturer, use an EtherCAT Coupler Unit with unit version 1.5 or later.

## NX-TC

## Connected to a Communications EtherNet/IP Coupler Unit

NX Unit		Corresponding version*1					
Model	Unit Version	Application with an NJ/NX/NY-series Controller *2			Application with an CS/CJ/CP-series PLC *3		
		EtherNet/IP Coupler Unit	CPU Unit or Industrial PC	Sysmac Studio	EtherNet/IP Coupler Unit	Sysmac Studio	NX-IO Configurator
NX-TC2405	Ver.1.0	Ver.1.2	Ver.1.14	Ver.1.21	Ver.1.2	Ver.1.21	Ver.1.21
	Ver.1.1			Ver.1.22		Ver.1.22	
	Ver.1.2			Ver.1.30		Ver.1.30	Ver.1.21
	Ver.1.3			Ver.1.40		Ver.1.40	Ver.1.22
NX-TC2406	Ver.1.0			Ver.1.21		Ver.1.21	
	Ver.1.1			Ver.1.22		Ver.1.22	
	Ver.1.2			Ver.1.30		Ver.1.21	
	Ver.1.3			Ver.1.40		Ver.1.22	
NX-TC2407	Ver.1.0			Ver.1.21		Ver.1.21	
	Ver.1.1			Ver.1.22		Ver.1.22	
	Ver.1.2			Ver.1.30		Ver.1.21	
	Ver.1.3			Ver.1.40		Ver.1.22	
NX-TC2408	Ver.1.0			Ver.1.21		Ver.1.21	
	Ver.1.1			Ver.1.22		Ver.1.22	
	Ver.1.2			Ver.1.30		Ver.1.21	
	Ver.1.3			Ver.1.40		Ver.1.22	
NX-TC3405	Ver.1.0			Ver.1.21		Ver.1.21	
	Ver.1.1			Ver.1.22		Ver.1.22	
	Ver.1.2			Ver.1.30		Ver.1.21	
	Ver.1.3			Ver.1.40		Ver.1.22	
NX-TC3406	Ver.1.0			Ver.1.21		Ver.1.21	
	Ver.1.1			Ver.1.22		Ver.1.22	
	Ver.1.2			Ver.1.30		Ver.1.21	
	Ver.1.3			Ver.1.40		Ver.1.22	
NX-TC3407	Ver.1.0			Ver.1.21		Ver.1.21	
	Ver.1.1			Ver.1.22		Ver.1.22	
	Ver.1.2			Ver.1.30		Ver.1.21	
	Ver.1.3			Ver.1.40		Ver.1.22	
NX-TC3408	Ver.1.0	Ver.1.21	Ver.1.21				
	Ver.1.1	Ver.1.22	Ver.1.22				
	Ver.1.2	Ver.1.30	Ver.1.21				
	Ver.1.3	Ver.1.40	Ver.1.22				

\*1. Some Units do not have all of the versions given in the above table. If a Unit does not have the specified version, support is provided by the oldest available version after the specified version. Refer to the user's manuals for the specific Units for the relation between models and versions.

\*2. Refer to the user's manual of the EtherNet/IP Coupler Unit for the unit versions of EtherNet/IP Units corresponding to EtherNet/IP Coupler Units.

\*3. Refer to the user's manual of the EtherNet/IP Coupler Unit for the unit versions of CPU Units and EtherNet/IP Units corresponding to EtherNet/IP Coupler Units.

## External Interface

### Temperature Control Unit

#### NX-TC2405/2406/2407/2408 (2 Ch Type)

12mm Width

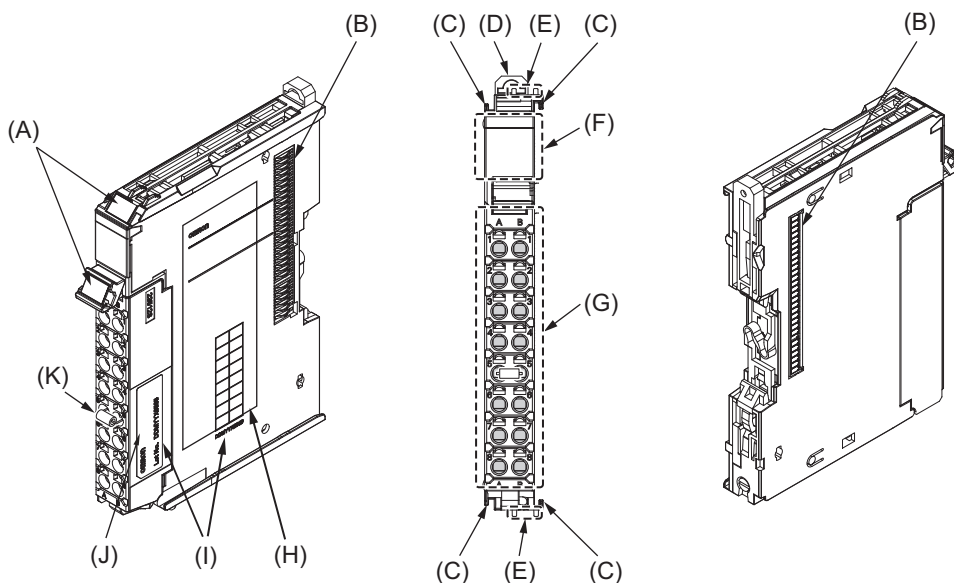

#### NX-TC3405/3406/3407/3408 (4 Ch Type)

24mm Width

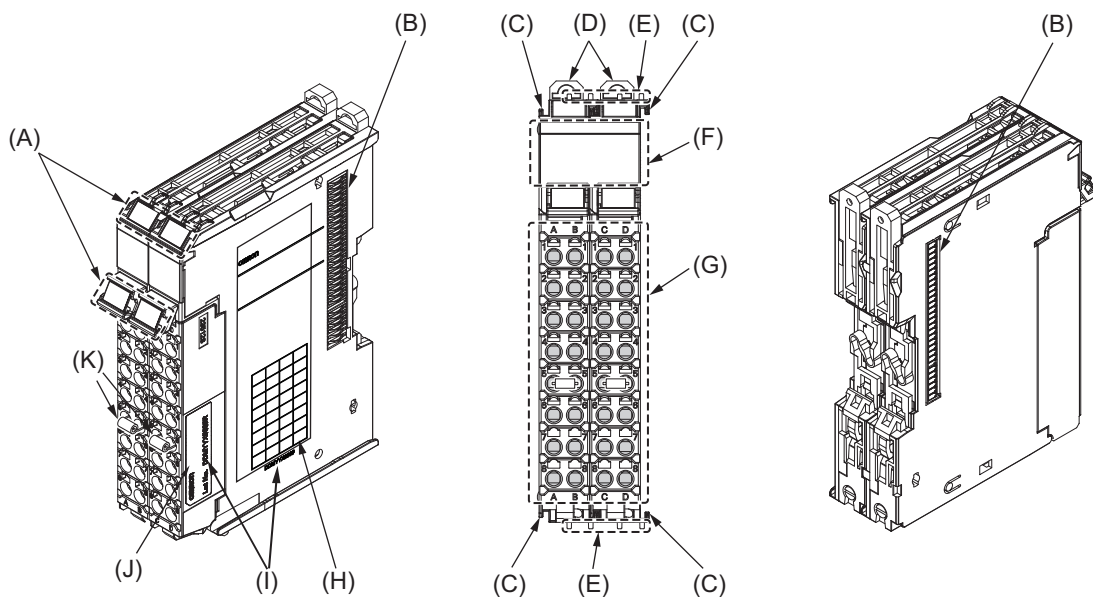

Letter	Item	Specification
(A)	Marker attachment locations	The locations where markers are attached. The markers made by OMRON are installed for the factory setting. Commercially available markers can also be installed.
(B)	NX bus connector	This connector is used to connect each Unit.
(C)	Unit hookup guides	These guides are used to connect two Units.
(D)	DIN Track mounting hooks	These hooks are used to mount the NX Unit to a DIN Track.
(E)	Protrusions for removing the Unit	The protrusions to hold when removing the Unit.
(F)	Indicators	The indicators show the current operating status of the Unit.
(G)	Terminal block	The terminal block is used to connected external devices. The number of terminals depends on the type of Unit.
(H)	Unit specifications	The specifications of the Unit are given.
(I)	Calibration control number	The calibration control number is used to guarantee overall accuracy. The overall accuracy is guaranteed by using the terminal block and the Unit as a set that have the same calibration control number.
(J)	Calibration control number label	The label attached on the terminal block with a calibration control number written on it. With 24 mm wide models, the labels are attached on both left and right terminal blocks. "L" or "R" is appended at the end of the calibration control number to identify left or right.
(K)	Cold junction sensor	This sensor is used to perform the cold junction compensation. The sensors are mounted on both left and right terminal blocks for models with 24 mm width.

# NX-TC

## Terminal Blocks

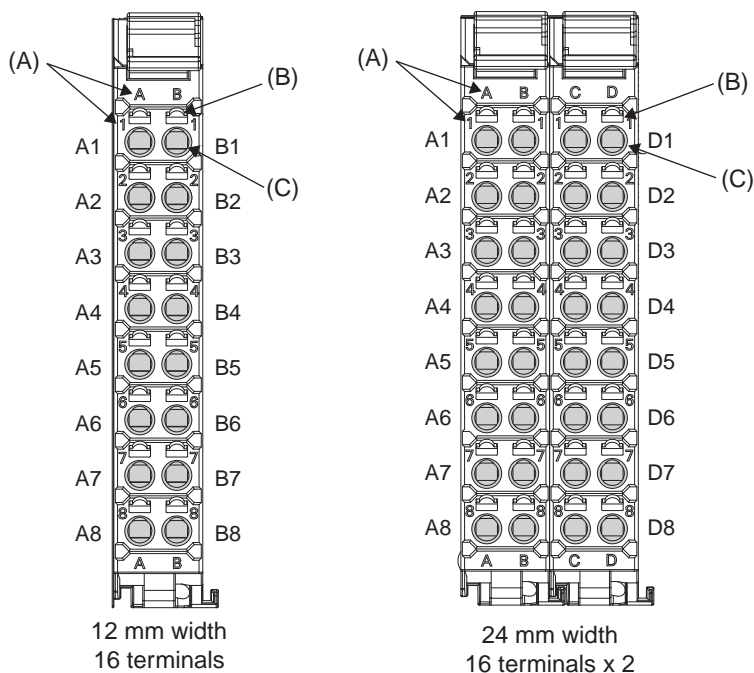

Letter	Item	Specification
(A)	Terminal number indications	Terminal numbers for which A to D indicate the column, and 1 to 8 indicate the line are displayed. The terminal number is a combination of column and line, i.e. A1 to A8 and B1 to B8. For models of 24 mm width, A1 to A8 and B1 to B8 are terminal number of the left terminal block, C1 to C8 and D1 to D8 are terminal numbers of the right terminal block. The terminal number indications are the same regardless of the number of terminals on the terminal block.
(B)	Release holes	Insert a flat-blade screwdriver into these holes to connect and remove the wires.
(C)	Terminal holes	The wires are inserted into these holes.

## Applicable Wires

### Using Ferrules

If you use ferrules, attach the twisted wires to them.

Observe the application instructions for your ferrules for the wire stripping length when attaching ferrules.

Always use plated one-pin ferrules. Do not use unplated ferrules or two-pin ferrules.

The applicable ferrules, wires, and crimping tool are given in the following table.

Terminal type	Manufacturer	Ferrule model	Applicable wire (mm <sup>2</sup> (AWG))	Crimping tool
Terminals other than ground terminals	Phoenix Contact	AI0,34-8	0.34 (#22)	Phoenix Contact (The figure in parentheses is the applicable wire size.) CRIMPFOX 6 (0.25 to 6 mm <sup>2</sup> , AWG24 to 10)
		AI0,5-8	0.5 (#20)	
		AI0,5-10		
		AI0,75-8	0.75 (#18)	
		AI0,75-10		
		AI1,0-8	1.0 (#18)	
		AI1,0-10		
		AI1,5-8	1.5 (#16)	
AI1,5-10				
Ground terminals		AI2,5-10	2.0 *	
Terminals other than ground terminals	Weidmuller	H0.14/12	0.14 (#26)	Weidmuller (The figure in parentheses is the applicable wire size.) PZ6 Roto (0.14 to 6 mm <sup>2</sup> , AWG 26 to 10)
		H0.25/12	0.25 (#24)	
		H0.34/12	0.34 (#22)	
		H0.5/14	0.5 (#20)	
		H0.5/16		
		H0.75/14	0.75 (#18)	
		H0.75/16		
		H1.0/14	1.0 (#18)	
		H1.0/16		
		H1.5/14	1.5 (#16)	
H1.5/16				

\* Some AWG 14 wires exceed 2.0 mm<sup>2</sup> and cannot be used in the screwless clamping terminal block.

When you use any ferrules other than those in the above table, crimp them to the twisted wires so that the following processed dimensions are achieved.

Finished Dimensions of Ferrules

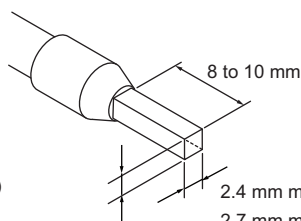

1.6 mm max. (except ground terminals)  
2.0 mm max. (ground terminals)

2.4 mm max. (except ground terminals)  
2.7 mm max. (ground terminals)

### Using Twisted Wires/Solid Wires

If you use the twisted wires or the solid wires, use the following table to determine the correct wire specifications.

Terminals		Wire type				Wire size	Conductor length (stripping length)
		Twisted wires		Solid wire			
Classification	Current capacity	Plated	Unplated	Plated	Unplated		
All terminals except ground terminals	2 A or less	Possible	Possible	Possible	Possible	0.08 to 1.5 mm <sup>2</sup> AWG28 to 16	8 to 10 mm
	Greater than 2 A and 4 A or less		Not Possible	Possible *1	Not Possible		
	Greater than 4 A		Possible *1	Not Possible	Not Possible		
Ground terminals	---	Possible	Possible	Possible *2	Possible *2	2.0 mm <sup>2</sup>	9 to 10 mm

\*1. Secure wires to the screwless clamping terminal block. Refer to the Securing Wires in the USER'S MANUAL for how to secure wires.

\*2. With the NX-TB□□□1 Terminal Block, use twisted wires to connect the ground terminal. Do not use a solid wire.

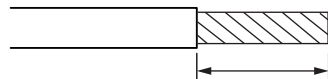

Conductor length (stripping length)

**Note: <Additional Information>** If more than 2 A will flow on the wires, use plated wires or use ferrules.

# NX-TC

## Dimensions

(Unit/mm)

### Temperature Control Unit

NX-TC2405/2406/2407/2408 (2 Ch type)  
12 mm Width

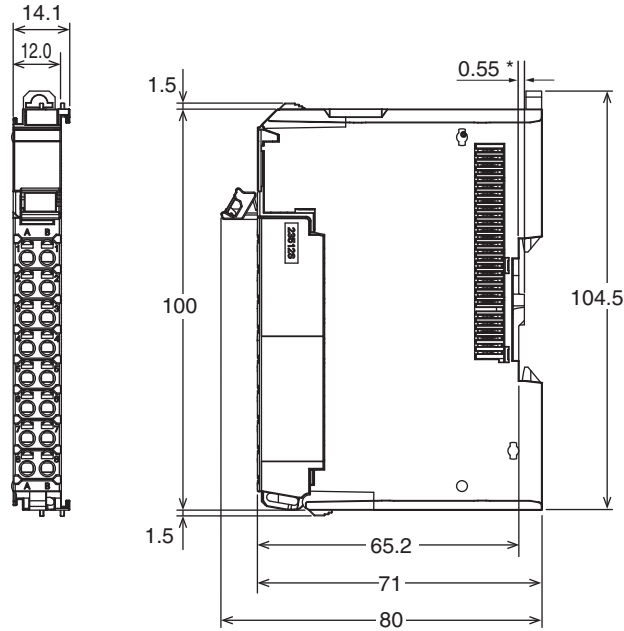

NX-TC3405/3406/3407/3408 (4 Ch type)  
24 mm Width

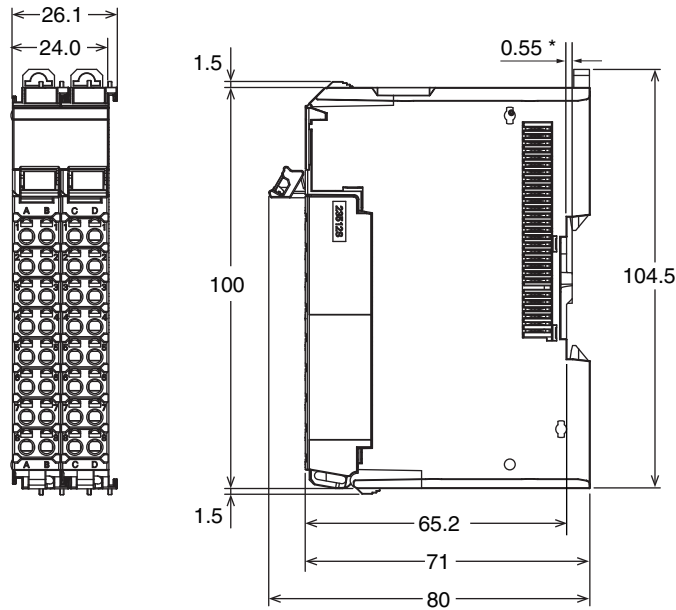

## Related Manual

Cat. No.	Model number	Manual name	Application	Description
H228	NX-TC□□□□	NX-series User's Manual for Temperature Control Units	Learning how to use NX-series Temperature Control Units	The hardware, setup methods, and functions of the NX-series Temperature Control Units are described.

# Terms and Conditions Agreement

## **Read and understand this catalog.**

Please read and understand this catalog before purchasing the products. Please consult your OMRON representative if you have any questions or comments.

## **Warranties.**

- (a) Exclusive Warranty. Omron's exclusive warranty is that the Products will be free from defects in materials and workmanship for a period of twelve months from the date of sale by Omron (or such other period expressed in writing by Omron). Omron disclaims all other warranties, express or implied.
- (b) Limitations. OMRON MAKES NO WARRANTY OR REPRESENTATION, EXPRESS OR IMPLIED, ABOUT NON-INFRINGEMENT, MERCHANTABILITY OR FITNESS FOR A PARTICULAR PURPOSE OF THE PRODUCTS. BUYER ACKNOWLEDGES THAT IT ALONE HAS DETERMINED THAT THE PRODUCTS WILL SUITABLY MEET THE REQUIREMENTS OF THEIR INTENDED USE.

Omron further disclaims all warranties and responsibility of any type for claims or expenses based on infringement by the Products or otherwise of any intellectual property right. (c) Buyer Remedy. Omron's sole obligation hereunder shall be, at Omron's election, to (i) replace (in the form originally shipped with Buyer responsible for labor charges for removal or replacement thereof) the non-complying Product, (ii) repair the non-complying Product, or (iii) repay or credit Buyer an amount equal to the purchase price of the non-complying Product; provided that in no event shall Omron be responsible for warranty, repair, indemnity or any other claims or expenses regarding the Products unless Omron's analysis confirms that the Products were properly handled, stored, installed and maintained and not subject to contamination, abuse, misuse or inappropriate modification. Return of any Products by Buyer must be approved in writing by Omron before shipment. Omron Companies shall not be liable for the suitability or unsuitability or the results from the use of Products in combination with any electrical or electronic components, circuits, system assemblies or any other materials or substances or environments. Any advice, recommendations or information given orally or in writing, are not to be construed as an amendment or addition to the above warranty.

See <http://www.omron.com/global/> or contact your Omron representative for published information.

## **Limitation on Liability; Etc.**

OMRON COMPANIES SHALL NOT BE LIABLE FOR SPECIAL, INDIRECT, INCIDENTAL, OR CONSEQUENTIAL DAMAGES, LOSS OF PROFITS OR PRODUCTION OR COMMERCIAL LOSS IN ANY WAY CONNECTED WITH THE PRODUCTS, WHETHER SUCH CLAIM IS BASED IN CONTRACT, WARRANTY, NEGLIGENCE OR STRICT LIABILITY.

Further, in no event shall liability of Omron Companies exceed the individual price of the Product on which liability is asserted.

## **Suitability of Use.**

Omron Companies shall not be responsible for conformity with any standards, codes or regulations which apply to the combination of the Product in the Buyer's application or use of the Product. At Buyer's request, Omron will provide applicable third party certification documents identifying ratings and limitations of use which apply to the Product. This information by itself is not sufficient for a complete determination of the suitability of the Product in combination with the end product, machine, system, or other application or use. Buyer shall be solely responsible for determining appropriateness of the particular Product with respect to Buyer's application, product or system. Buyer shall take application responsibility in all cases.

NEVER USE THE PRODUCT FOR AN APPLICATION INVOLVING SERIOUS RISK TO LIFE OR PROPERTY OR IN LARGE QUANTITIES WITHOUT ENSURING THAT THE SYSTEM AS A WHOLE HAS BEEN DESIGNED TO ADDRESS THE RISKS, AND THAT THE OMRON PRODUCT(S) IS PROPERLY RATED AND INSTALLED FOR THE INTENDED USE WITHIN THE OVERALL EQUIPMENT OR SYSTEM.

## **Programmable Products.**

Omron Companies shall not be responsible for the user's programming of a programmable Product, or any consequence thereof.

## **Performance Data.**

Data presented in Omron Company websites, catalogs and other materials is provided as a guide for the user in determining suitability and does not constitute a warranty. It may represent the result of Omron's test conditions, and the user must correlate it to actual application requirements. Actual performance is subject to the Omron's Warranty and Limitations of Liability.

## **Change in Specifications.**

Product specifications and accessories may be changed at any time based on improvements and other reasons. It is our practice to change part numbers when published ratings or features are changed, or when significant construction changes are made. However, some specifications of the Product may be changed without any notice. When in doubt, special part numbers may be assigned to fix or establish key specifications for your application. Please consult with your Omron's representative at any time to confirm actual specifications of purchased Product.

## **Errors and Omissions.**

Information presented by Omron Companies has been checked and is believed to be accurate; however, no responsibility is assumed for clerical, typographical or proofreading errors or omissions.

**OMRON Corporation Industrial Automation Company**

Kyoto, JAPAN

Contact: [www.ia.omron.com](http://www.ia.omron.com)

**Regional Headquarters**

**OMRON EUROPE B.V.**

Wegalaan 67-69, 2132 JD Hoofddorp  
The Netherlands

Tel: (31)2356-81-300/Fax: (31)2356-81-388

**OMRON ELECTRONICS LLC**

2895 Greenspoint Parkway, Suite 200  
Hoffman Estates, IL 60169 U.S.A.

Tel: (1) 847-843-7900/Fax: (1) 847-843-7787

**OMRON ASIA PACIFIC PTE. LTD.**

No. 438A Alexandra Road # 05-05/08 (Lobby 2),  
Alexandra Technopark,  
Singapore 119967

Tel: (65) 6835-3011/Fax: (65) 6835-2711

**OMRON (CHINA) CO., LTD.**

Room 2211, Bank of China Tower,  
200 Yin Cheng Zhong Road,  
PuDong New Area, Shanghai, 200120, China  
Tel: (86) 21-5037-2222/Fax: (86) 21-5037-2200

**Authorized Distributor:**

© OMRON Corporation 2017-2020 All Rights Reserved.  
In the interest of product improvement,  
specifications are subject to change without notice.

**CSM\_1\_7**  
**Cat. No. H229-E1-04**

0320(1217)



# SCATTERGOOD & JOHNSON LTD

ELECTRICAL ENGINEERING & FLUID CONTROL DISTRIBUTORS

Est.1899

At Scattergood & Johnson Ltd, we pride ourselves on being a technical distributor to specialist industries.

Working with a range of quality product suppliers across a number of specialist markets, we are not your average 'box shifter' - we are your technical and supply chain partner.

We fully support every product we sell - for free! Our internal team and external sales engineers can answer any product or application question, no matter the complexity.

Backing up this technical ability is a range of 50,000+ products available from stock for nationwide next day delivery (same day if required!), or you can collect what you need from any of our trade counters around the UK.

Select your specialist interest below to learn more about how we can help.

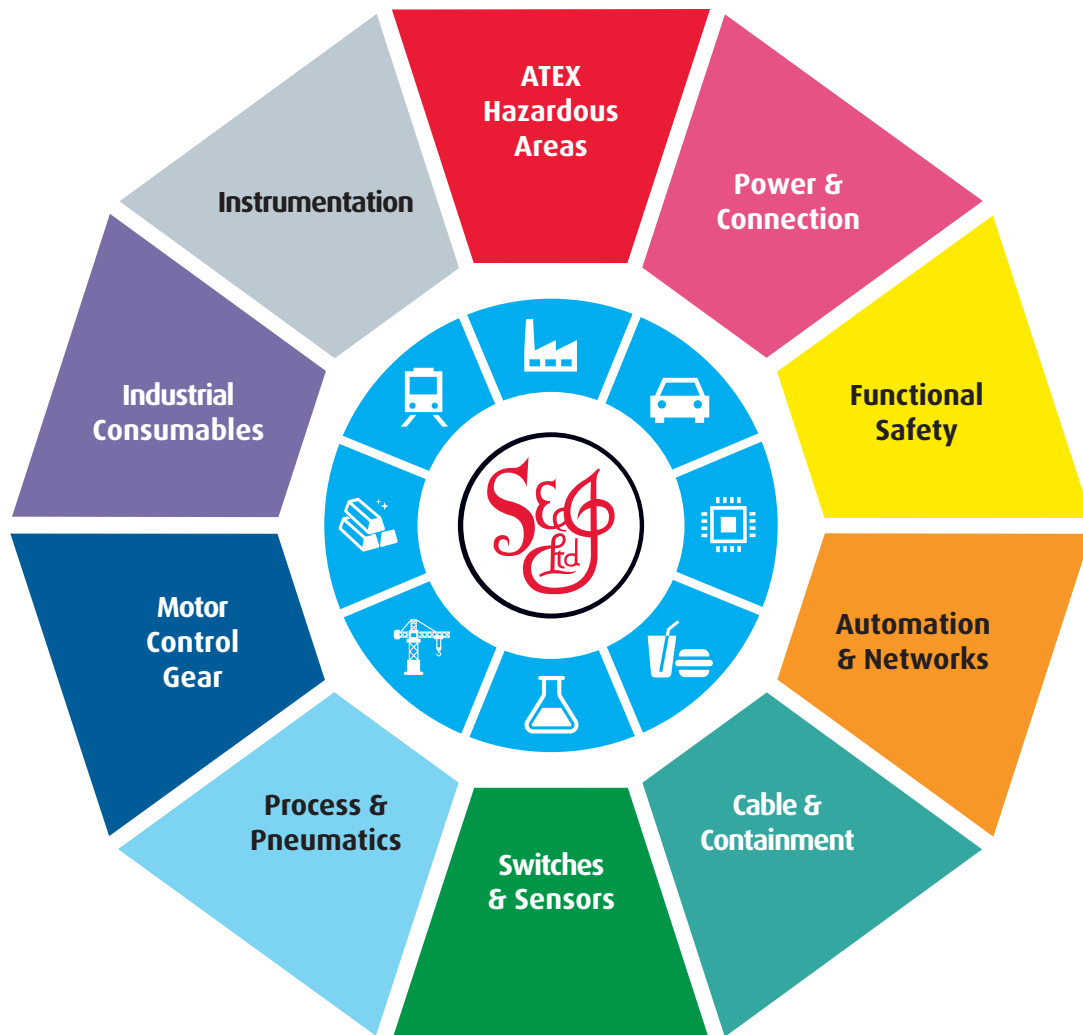

Online, In Branch and On the Road - Scattergood & Johnson Ltd, there when you need us.

# [www.scatts.co.uk](http://www.scatts.co.uk)