

NX7□

# NX7 series machine controller

## Sysmac controller - NX7 series

The NX7 series is a high performance machine controller that includes two synchronized motion cores controlling up to 256 axes.

- Fastest cycle time: 125  $\mu$ s
- Number of axes: 256, 128
- Two synchronized motion cores
- Functions: Logic sequence and Motion
- Multi-tasking
- Built-in EtherCAT and two EtherNet/IP (1 Gbps) ports
- Fully conforms to IEC 61131-3 standards
- Certified PLCopen function blocks for motion control



## System configuration

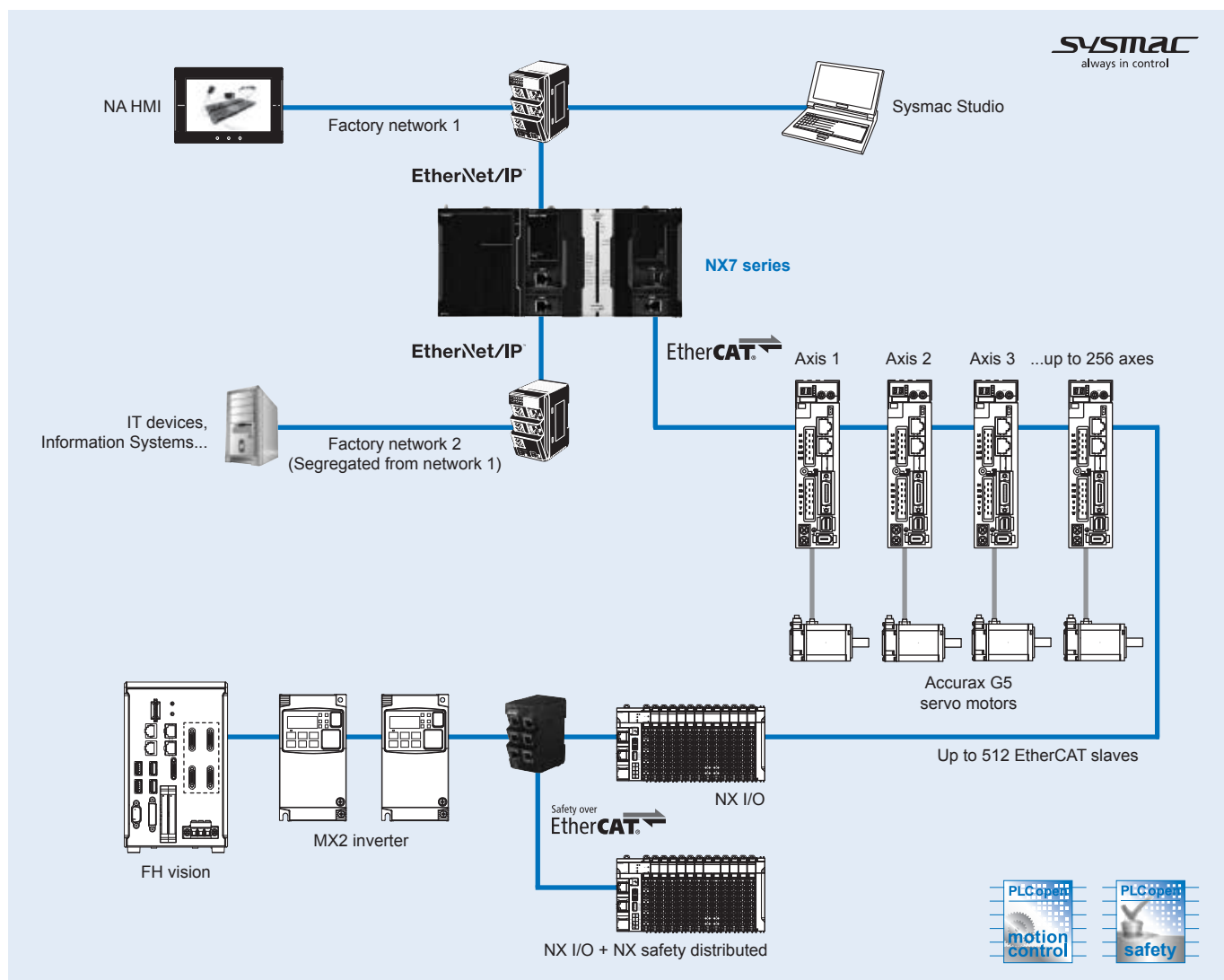

## Specifications

## General specifications

Item	NX7□ CPU Unit	
Enclosure	Mounted in a panel	
Grounding	Less than 100 Ω	
CPU unit dimensions (H × D × W)	100 mm × 100 mm × 132 mm	
Weight	880 g (including end cover)	
Power consumption	40 W (including SD Memory card and end cover)	
Operation environment	Ambient operating temperature	0 to 55°C
	Ambient operating humidity	10% to 95% (with non condensation)
	Atmosphere	Must be free from corrosive gases
	Ambient storage temperature	-25 to 70°C (excluding battery)
	Altitude	2,000 m or less
	Pollution degree	2 or less: Conforms to JIS B3502 and IEC 61131-2.
	Noise immunity	2 kV on power supply line (conforms to IEC 61000-4-4.)
	Overvoltage category	Category II: Conforms to JIS B3502 and IEC 61131-2
	EMC immunity level	Zone B
	Vibration resistance	Conforms to IEC 60068-2-6 5 to 8.4 Hz with 3.5 mm amplitude, 8.4 to 150 Hz. Acceleration of 9.8 m/s <sup>2</sup> for 100 min in X, Y and Z directions (10 sweeps of 10 min each = 100 min total)
Shock resistance	Conforms to IEC 60068-2-27 147 m/s <sup>2</sup> , 3 times in X, Y and Z directions (100 m/s <sup>2</sup> for relay output units)	
Battery	Life	2.5 years (at 25°C, power ON time rate 0% (power OFF))
	Model	CJ1W-BAT01
Applicable standards	Conforms to cULus, EC directives, RCM and KC registration.	

## Performance specifications

Item	NX701-1700		NX701-1600	
Processing time	Instruction execution time	LD instruction	0.37 ns or more	
		Math instructions (for long real data)	3.2 ns or more	
Programming	Program capacity <sup>1</sup>	Size	80 MB	
		POU definition	6,000	
		POU instance	48,000	
	Variables capacity	No retain attribute	Size: 256 MB Number: 360,000	
Retain attribute		Size: 4 MB Number: 40,000		
Data type	Number	8,000		
Unit configuration	Maximum number of NX unit on the system		4,096 (on NX EtherCAT communication coupler unit)	
	Number of expansion racks		0	
	Power supply unit for CPU rack and expansion racks	Model	NX-PA9001 NX-PD7001	
		Power OFF detection time	AC power supply	30 to 45 ms
			DC power supply	5 to 20 ms
Motion control	Number of controlled axes	Number of real axes <sup>2</sup>	256 axes max. / 128 axes max.	
		Number of total axes <sup>3</sup>	256 axes max. / 128 axes max.	
		Linear interpolation control	4 axes max. per axes group	
		Circular interpolation control	2 axes per axes group	
	Number of axes groups		64 groups max.	
	Position units		Pulses, millimeters, micrometers, nanometers, degrees or inches	
	Override factors		0.00% or 0.01% to 500.00%	
	Motion control period		Same as process data communications period of EtherCAT communications	
	Cams	Number of cam data points	65,535 points max. per cam table / 1,048,560 points max. for all cam tables	
		Number of cam tables	640 tables max.	
Communications	Peripheral USB port	Supported services	Sysmac Studio connection	
		Physical layer	USB 2.0-compliant B-type connector	
		Transmission distance	5 m max.	

Item		NX701-1700	NX701-1600	
Communications	Built-in EtherNet/IP port	Number of ports	2	
		Physical layer	10BASE-T/100BASE-TX/1000BASE-T	
		Frame length	1514 max.	
		Media access method	CSMA/CD	
		Modulation	Baseband	
		Topology	Star	
		Baud rate	1 Gbps (1000BASE-T)	
		Transmission media	STP (shielded, twisted-pair) cable of Ethernet category 5, 5e or higher	
		Transmission distance	100 m max. (distance between Ethernet switch and node)	
		Cascade connections number	There are no restrictions if an switching hub is used	
		CIP service: Tag data links (cyclic communications)	Number of connections	256 per port, total 512
			Packet interval <sup>4</sup>	0.5 to 10,000 ms in 0.5-ms increments. Can be set for each connection.
			Permissible communications band	40,000 pps <sup>5</sup> (including heartbeat)
			Number of tag sets	256 per port, total 512
			Tag types	Network variables
			Number of tags	8 (7 tags if controller status is included in the tag set.)
			Link data size per node	256 per port, total 512
	Number of tag		369,664 bytes max.	
	Data size per connection		1,444 bytes max.	
	Number of registrable tag sets		256 per port, total 512 (1 connection = 1 tag set)	
	Tag set size	1,444 bytes max. (two bytes are used if controller status is included in the tag set.)		
	Multi-cast packet filter <sup>6</sup>	Supported.		
	CIP message service: Explicit messages	Class 3 (number of connections)	128 per port, total 256 (clients plus server)	
		UCMM (non-connection type)	Number of clients that can communicate at one time: 32 per port, total 64 Number of servers that can communicate at one time: 32 per port, total 64	
		Number of TCP socket service	30 max.	
	Built-in EtherCAT port	Communications standard	IEC 61158, Type 12	
		EtherCAT master specifications	Class B (feature pack motion control compliant)	
		Physical layer	100BASE-TX	
		Modulation	Baseband	
		Baud rate	100 Mbps (100Base-TX)	
		Duplex mode	Automatic	
		Topology	Line, daisy chain and branching	
		Transmission media	Twisted-pair cable of category 5 or higher (double-shielded straight cable with aluminum tape and braiding)	
Transmission distance		Distance between nodes: 100 m max.		
Number of slaves		512 max.		
Process data size		Inputs/Outputs: 11,472 bytes max.		
Process data size per slave		Inputs/Outputs: 1,434 bytes max.		
Communications cycle		<ul style="list-style-type: none"> <li>Primary periodic task: 125 μs, 250 μs to 8 ms (in 250 μs increments)</li> <li>Priority-5 periodic task: 125 μs, 250 μs to 100 ms (in 250 μs increments)</li> </ul>		
Sync jitter		1 μs max.		
Internal clock		At ambient temperature of 55°C: -3.5 to +0.5 min error per month At ambient temperature of 25°C: -1.5 to +1.5 min error per month At ambient temperature of 0°C: -3 to +1 min error per month		

<sup>\*1</sup> This is the capacity for the execution objects and variable tables (including variable names).

<sup>\*2</sup> This is the total number of axes that are set as servo axes or encoder axes and are also set as used axes.

<sup>\*3</sup> This is the total for all axis types.

<sup>\*4</sup> Data is updated on the line in the specified interval regardless of the number of nodes.

<sup>\*5</sup> Means packets per second, i.e., the number of communication packets that can be sent or received in one second.

<sup>\*6</sup> An IGMP client is mounted for the EtherNet/IP port. If an Ethernet switch that supports IGMP snooping is used, filtering of unnecessary multicast packets is performed.

## Function specifications

Item		NX7□ CPU Unit		
Tasks	Function	Function	I/O refreshing and the user program are executed in units that are called tasks. Tasks are used to specify execution conditions and execution priority.	
		Periodically executed tasks	Maximum number of primary periodic tasks: 1 Maximum number of periodic tasks: 4	
		Conditionally executed tasks	Maximum number of even tasks: 32 When active even task instruction is executed or when condition expression for variable is met.	
Programming	POUs (program organization units)	Programs	POUs that are assigned to tasks.	
		Function blocks	POUs that are used to create objects with specific conditions.	
		Functions	POUs that are used to create an object that determine unique outputs for the inputs, such as for data processing.	
	Programming languages	Types	Ladder diagrams <sup>1</sup> and structured text (ST).	
	Namespaces		A concept that is used to group identifiers for POU definitions.	
	Variables	External access of variables	Network variables (the function which allows access from the HMI, host computers or other controllers)	
	Data types	Basic data types		BOOL, BYTE, WORD, DWORD, LWORD, INT, SINT, DINT, LINT, UINT, USINT, UDINT, ULINT, REAL, LREAL, TIME (durations), DATE, TIME_OF_DAY, DATE_AND_TIME and STRING (text strings)
		Derivative data types		Structures, unions, enumerations
		Structures	Function	A derivative data type that groups together data with different variable types. Number of members: 2,048 max. Nesting levels: 8 max.
			Member data types	Basic data types, structures, unions, enumerations, array variables
			Specifying member offsets	You can use member offsets to place structure members at any memory locations.
		Unions	Function	A derivative data type that groups together data with different variable types. Number of members: 4 max.
			Member data types	BOOL, BYTE, WORD, DWORD and LWORD.
	Enumerations	Function	A derivative data type that uses text strings called enumerators to express variable values.	
	Data type attributes	Array specifications	Function	An array is a group of elements with the same data type. You specify the number (subscript) of the element from the first element to specify the element. Number of dimensions: 3 max. Number of elements: 65,535 max.
Array specifications for FB instances			Supported.	
Range specifications		You can specify a range for a data type in advance. The data type can take only values that are in the specified range.		
Libraries		User libraries.		
Motion control	Control modes		Position control, velocity control, torque control	
	Axis types		Servo axes, virtual servo axes, encoder axes and virtual encoder axes	
	Positions that can be managed		Command positions and actual positions	
	Single-axis	Single-axis position control	Absolute positioning	Positioning is performed for a target position that is specified with an absolute value.
			Relative positioning	Positioning is performed for a specified travel distance from the command current position.
			Interrupt feeding	Positioning is performed for a specified travel distance from the position where an interrupt input was received from an external input.
			Cyclic synchronous absolute positioning	The function which output command positions in every control period in the position control mode.
	Single-axis velocity control	Single-axis velocity control	Velocity control	Velocity control is performed in position control mode.
			Cyclic synchronous velocity control	A velocity command is output each control period in the velocity control mode.
	Single-axis torque control	Single-axis torque control	Torque control	The torque of the motor is controlled.
	Single-axis synchronized control	Single-axis synchronized control	Starting cam operation	A cam motion is performed using the specified cam table.
			Ending cam operation	The cam motion for the axis that is specified with the input parameter is ended.
			Starting gear operation	A gear motion with the specified gear ratio is performed between a master axis and slave axis.
			Positioning gear operation	A gear motion with the specified gear ratio and sync position is performed between a master axis and slave axis.
			Ending gear operation	The specified gear motion or positioning gear motion is ended.
			Synchronous positioning	Positioning is performed in sync with a specified master axis.
			Master axis phase shift	The phase of a master axis in synchronized control is shifted.
	Single-axis manual operation	Single-axis manual operation	Combining axes	The command positions of two axes are added or subtracted and the result is output as the command position.
			Powering the servo	The servo in the servo drive is turned ON to enable axis motion.
			Jogging	An axis is jogged at a specified target velocity.

Item			NX7□ CPU Unit			
Motion control	Single-axis	Auxiliary functions for single-axis control	Resetting axis errors	Axes errors are cleared.		
			Homing	A motor is operated and the limit signals, home proximity signal, and home signal are used to define home.		
			Homing with parameter	Specifying the parameter, a motor is operated and the limit signals, home proximity signal and home signal are used to define home.		
			High-speed homing	Positioning is performed for an absolute target position of 0 to return to home.		
			Stopping	An axis is decelerated to a stop at the specified rate.		
			Immediately stopping	An axis is stopped immediately.		
			Override factors	The target velocity of an axis can be changed.		
			Changing the current position	The command current position or actual current position of an axis can be changed to any position.		
			Enabling external latches	The position of an axis is recorded when a trigger occurs.		
			Disabling external latches	The current latch is disabled.		
			Zone monitoring	You can monitor the command position or actual position of an axis to see when it is within a specified range (zone).		
			Enabling digital cam switches	You can turn a digital output ON and OFF according to the position of an axis.		
			Monitoring axis following error	You can monitor whether the difference between the command positions or actual positions of two specified axes exceeds a threshold value.		
			Resetting the following error	The error between the command current position and actual current position is set to 0.		
			Torque limit	The torque control function of the servo drive can be enabled or disabled and the torque limits can be set to control the output torque.		
			Position compensation	The function which compensate the position for the axis in operation.		
			Start velocity	You can set the initial velocity when axis motion starts.		
			Axes groups	Multi-axes coordinated control	Absolute linear interpolation	Linear interpolation is performed to a specified absolute position.
					Relative linear interpolation	Linear interpolation is performed to a specified relative position.
	Circular 2D interpolation	Circular interpolation is performed for two axes.				
	Axes group cyclic synchronous absolute positioning	A positioning command is output each control period in Position control mode.				
	Auxiliary functions for multi-axes coordinated control	Resetting axes group errors		Axes group errors and axis errors are cleared.		
		Enabling axes groups		Motion of an axes group is enabled.		
		Disabling axes groups		Motion of an axes group is disabled.		
		Stopping axes groups		All axes in interpolated motion are decelerated to a stop.		
		Immediately stopping axes groups		All axes in interpolated motion are stopped immediately.		
		Setting axes group override factors		The blended target velocity is changed during interpolated motion.		
	Common items	Cams	Setting cam table properties	The end point index of the cam table that is specified in the input parameter is changed.		
			Saving cam tables	The cam table that is specified with the input parameter is saved in non-volatile memory in the CPU unit.		
			Generating cam tables	The cam table that is specified with the input parameter is generated from the cam property and cam mode.		
	Parameters	Writing MC settings	Some of the axis parameters or axes group parameters are overwritten temporarily.			
		Changing axis parameters	You can access and change the axis parameters from the user program.			

Item			NX7□ CPU Unit		
Motion control	Auxiliary functions	Count modes		You can select either linear mode (finite length) or rotary mode (infinite length).	
		Unit conversions		You can set the display unit for each axis according to the machine.	
		Acceleration/deceleration control	Automatic acceleration/deceleration control	Jerk is set for the acceleration/deceleration curve for an axis motion or axes group motion.	
			Changing the acceleration and deceleration rates	You can change the acceleration or deceleration rate even during acceleration or deceleration.	
		In-position check		You can set an in-position range and in-position check time to confirm when positioning is completed.	
		Stop method		You can set the stop method to the immediate stop input signal or limit input signal.	
		Re-execution of motion control instructions		You can change the input variables for a motion control instruction during execution and execute the instruction again to change the target values during operation.	
		Multi-execution of motion control instructions (buffer mode)		You can specify when to start execution and how to connect the velocities between operations when another motion control instruction is executed during operation.	
		Continuous axes group motions (transition mode)		You can specify the transition mode for multi-execution of instructions for axes group operation.	
		Monitoring functions	Software limits		Software limits are set for each axis.
			Following error		The error between the command current value and the actual current value is monitored for an axis.
			Velocity, acceleration/deceleration rate, torque, interpolation velocity and interpolation acceleration/deceleration rate		You can set warning values for each axis and each axes group.
		Absolute encoder support		You can use an OMRON Accurax-G5 series servomotor with an absolute encoder to eliminate the need to perform homing at startup.	
Input signal logic inversion		You can inverse the logic of immediate stop input signal, positive limit input signal, negative limit input signal or home proximity input signal.			
External interface signals		The servo drive input signals listed on below are used. Home signal, home proximity signal, positive limit signal, negative limit signal, immediate stop signal and interrupt input signal.			
Unit (I/O) management	EtherCAT slaves	Number of slaves	512 max.		
Communications	Peripheral USB port		A port for communications with various kinds of support software running on a personal computer.		
	EtherNet/IP port	Communication protocol		TCP/IP, UDP/IP	
		CIP communications service	Tag data links	Programless cyclic data exchange is performed with the devices on the EtherNet/IP network.	
			Message communications	CIP commands are sent to or received from the devices on the EtherNet/IP network.	
		TCP/IP applications	Socket services		Data is sent to and received from any node on EtherNet using the UDP or TCP protocol. Socket communications instructions are used.
			FTP client		File can be read from or written to computers to other Ethernet nodes from the CPU unit. FTP client communications instructions are used.
			FTP server		Files can be read from or written to the SD memory card in the CPU unit from computers at other Ethernet nodes.
			Automatic clock adjustment		Clock information is read from the NTP server at the specified time or at specified interval after the power supply to the CPU unit is turned ON. The internal clock time in the CPU unit is updated with the read time.
		SNMP agent		Built-in EtherNet/IP port internal status information is provided to network management software that uses an SNMP manager.	
	EtherCAT port	Supported services	Process data communications	Control information is exchanged in cyclic communications between the EtherCAT master and slaves.	
			SDO communications	A communication method to exchange control information in noncyclic event communications between the EtherCAT master and slaves. This communications method is defined by CoE.	
		Network scanning		Information is read from connected slave devices and the slave configuration is automatically generated.	
		DC (distributed clock)		Time is synchronized by sharing the EtherCAT system time between all EtherCAT devices (including the master).	
		Packet monitoring		The frames that are sent by the master and the frames that are received by the master can be saved. The data that is saved can be viewed with WireShark or other applications.	
		Enable/disable settings for slaves		The slaves can be enabled or disabled as communications targets.	
		Disconnecting/connecting slaves		SDO messages of the CAN application can be sent to slaves via EtherCAT.	
		Supported application protocol	CoE	SDO messages that conform to the CANopen standard can be sent to slaves via EtherCAT.	
	Communications instructions		The following instructions are supported: CIP communications instructions, socket communications instructions, SDO message instructions and FTP client instructions.		
	Operation management	RUN output contacts		The output on the power supply unit turns ON in RUN mode.	
	System management	Event logs	Function	Events are recorded in the logs.	
Number of events per event log			<ul style="list-style-type: none"> <li>System event log: 2,048 max.</li> <li>Access event log: 1,024 max.</li> <li>User-defined event log: 1,024 max.</li> </ul>		

Item		NX7□ CPU Unit			
Debugging	Online editing		Programs, function blocks, functions and global variables can be changed online. Different operators can change different POU's across a network.		
	Forced refreshing	Forced refreshing			
		Number of forced variables	For EtherCAT slaves	64 max.	
	MC test Run		Motor operation and wiring can be checked from the Sysmac Studio.		
	Synchronization		The project file in the Sysmac Studio and the data in the CPU unit can be made the same when online.		
	Differentiation monitoring	Differentiation monitoring		Rising/falling edge of contacts can be monitored.	
		Number of contacts		8 max.	
	Data tracing	Types	Single triggered trace	When the trigger condition is met, the specified number of samples are taken and then tracing stops automatically.	
			Continuous trace	Data tracing is executed continuously and the trace data is collected by the Sysmac Studio.	
		Number of simultaneous data trace		4 max.	
		Number of records		10,000 max.	
		Sampling	Number of sampled variables	192 variables max.	
		Timing of sampling		Sampling is performed for the specified task period, at the specified time or when a sampling instruction is executed.	
		Triggered traces	Triggered traces		Trigger conditions are set to record data before and after an event.
Trigger conditions			When BOOL variable changes to TRUE or FALSE. Comparison of non-BOOL variable with a constant. Comparison method: Equals (=), greater than (>), greater than or equals (≥), less than (<), less than or equals (≤), not equal (≠).		
Delay			Trigger position setting: A slider is used to set the percentage of sampling before and after the trigger condition is met.		
Simulation		The operation of the CPU unit is emulated in the Sysmac Studio.			
Reliability	Self-diagnosis	Controller error levels		Major fault, partial fault, minor fault, observation and information.	
		User-defined errors	User-defined errors	User-defined errors are registered in advance and then records are created by executing instructions.	
			Levels	8 levels	
Security	Protecting software assets and preventing operating mistakes	CPU unit names and serial IDs		When going online to a CPU Unit from the Sysmac Studio, the CPU Unit name in the project is compared to the name of the CPU Unit being connected to.	
		Protection	User program transfer with no restoration information	You can prevent reading data in the CPU unit from the Sysmac Studio.	
			CPU unit write protection	You can prevent writing data to the CPU unit from the Sysmac Studio or SD memory card.	
			Overall project file protection	You can use passwords to protect .smc files from unauthorized opening on the Sysmac Studio.	
			Data protection	You can use passwords to protect POU's on the Sysmac Studio.	
		Verification of operation authority	Verification of operation authority	Online operations can be restricted by operation rights to prevent damage to equipment or injuries that may be caused by operating mistakes.	
			Number of groups	5	
Verification of user program execution ID		The user program cannot be executed without entering a user program execution ID from the Sysmac Studio for the specific hardware (CPU unit).			
SD memory card	Storage type		SD memory card, SDHC memory card		
	Application	Automatic transfer from SD memory card		The data in the autoloader folder on an SD memory card is automatically loaded when the power supply to the controller is turned ON.	
		SD memory card operation instructions		You can access SD memory cards from instructions in the user program.	
		File operations from the Sysmac Studio		You can perform file operations for Controller files in the SD memory card and read/write standard document files on the computer.	
SD memory card life expiration detection		Notification of the expiration of the life of the SD memory card is provided in a system-defined variable and event log.			
Backup	SD memory card backup functions	Operation	Using front switch	You can use front switch to backup, compare or restore data.	
			Using system-defined variable	You can use system-defined variables to backup or compare data.	
			Memory card operations dialog box	Backup and verification operations can be performed from the SD memory card operations dialog box on the Sysmac Studio.	
			Using instruction	Backup operation can be performed by using instruction.	
		Protection	Backing up data to the SD memory card		Prohibit SD memory card backup functions.
			Sysmac Studio controller backup functions		

\*1 Inline ST is supported (Inline ST is ST that is written as an element in a ladder diagram).

**Nomenclature**

**NX7 CPU unit**

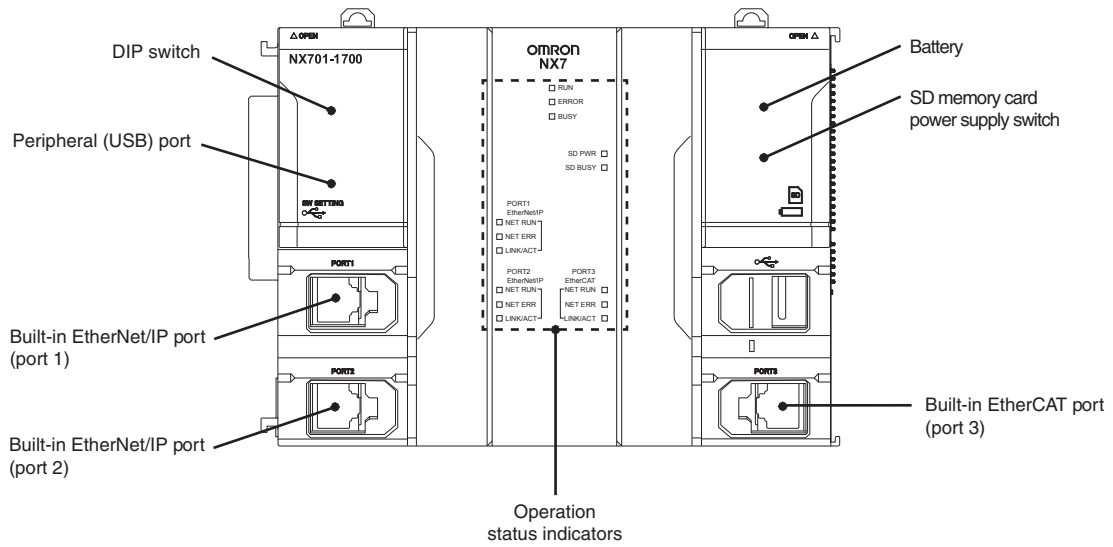

**100 to 240 VAC power supply unit (NX-PA9001)**

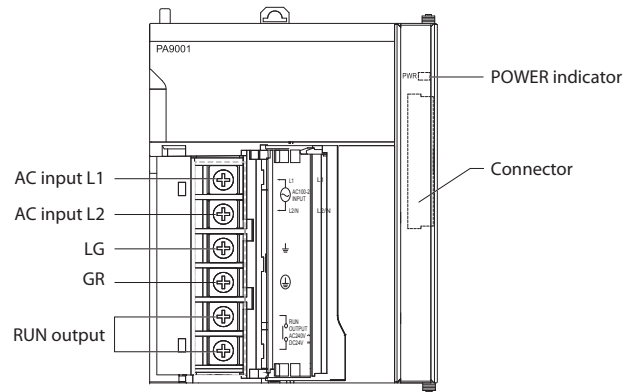

**24 VDC power supply unit (NX-PD7001)**

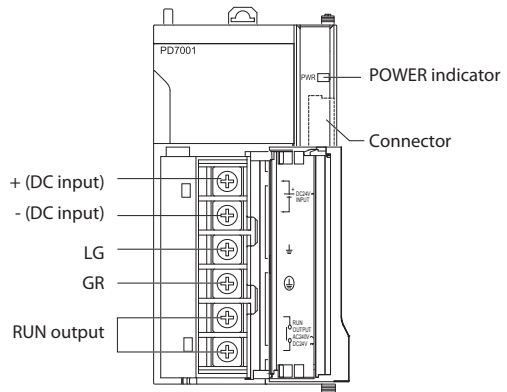

**Dimensions**

**Power supply unit (NX-PA9001/PD7001)**

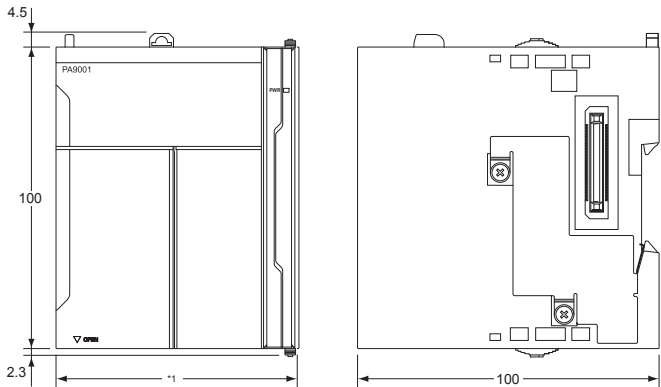

**Note: 1.** This dimension depends on the selected power supply unit:  
 - 51 mm: NX-PD7001  
 - 80 mm: NX-PA9001

**NX7 CPU unit**

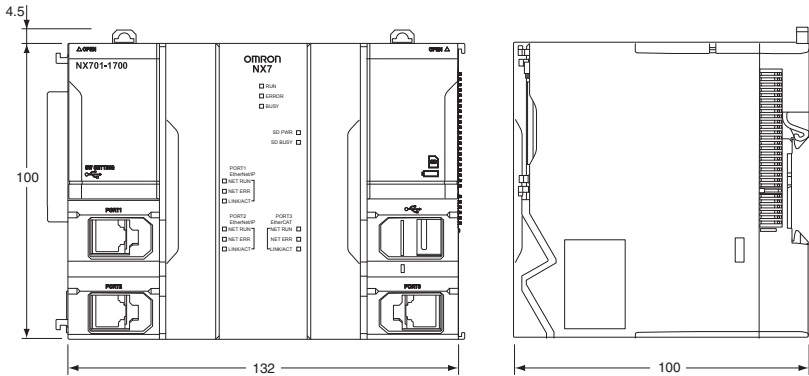

**End cover (NX-END01)**

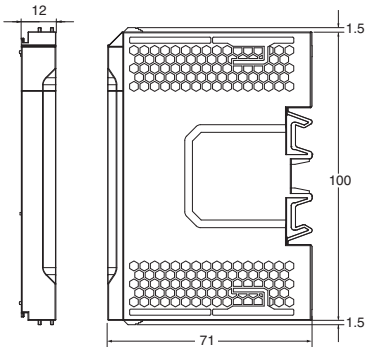

**Mounting height**

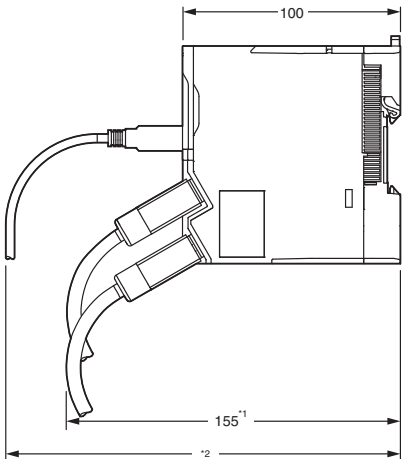

**Note: 1.** This is the dimension from the back of the unit to the communication cables:  
 - 155 mm: When an XS6G-T421-1 connector is used.  
**2.** This dimension depends on the specifications of the commercially available USB cable.

Ordering information

NX7 series system

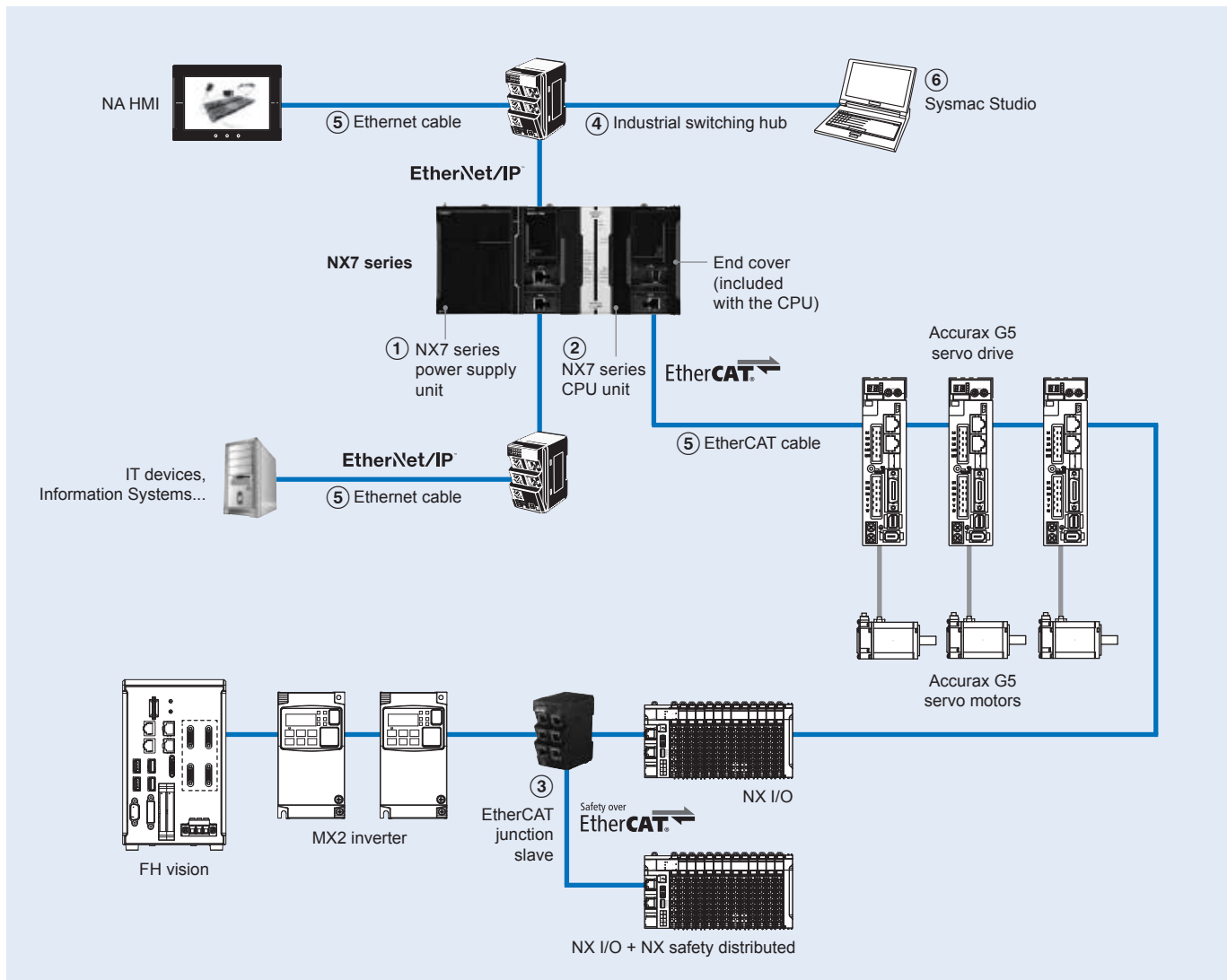

Power supply units



Symbol	Description	Output capacity	RUN output	Model
		Total		
①	100 to 240 VAC power supply unit for NX7 CPU	90 W	Supported	NX-PA9001
	24 VDC power supply unit for NX7 CPU	70 W		NX-PD7001

NX7 series CPU units

Symbol	CPU	Program capacity	Variables capacity	Specifications	Number of axes	Model
②	NX701	80 MB	4 MB: Retained	Power consumption: 40 W	256	NX701-1700
			256 MB: Not retained		128	NX701-1600

Note: The end cover unit NX-END01 is included with the CPU unit.

EtherCAT junction slave







Symbol	Name	No. of ports	Power supply voltage	Current consumption (A)	Dimensions (W x D x H)	Weight	Model	Appearance
③	EtherCAT junction slave	3	20.4 to 28.8 VDC (24 VDC -15 to 20%)	0.08	25 mm x 78 mm x 90 mm	165 g	GX-JC03	
		6		0.17	48 mm x 78 mm x 90 mm	220 g		

Note: 1. Please do not connect EtherCAT junction slave with OMRON position control unit, Model CJ1W-NC□81/□82.  
 2. EtherCAT junction slave cannot be used for Ethernet/IP and Ethernet.

Industrial switching hub

Symbol	Specifications			Accessories	Current consumption (A)	Model	Appearance
	Functions	No. of ports	Failure detection				
④	Quality of Service (QoS): EtherNet/IP control data priority. Failure detection: Broadcast storm and LSI error detection 10/100 BASE-TX, Auto-Negotiation	3	No	Power supply connector	0.22	W4S1-03B	
		5	No				
		5	Yes	Power supply connector and connector for informing error		W4S1-05B W4S1-05C	

Recommended EtherCAT and EtherNet/IP communication cables

Symbol	Item			Manufacturer	Colour	Cable length (m)	Model
⑤	EtherCAT cable	Cat 5e, AWG22, 2-pair cable M12/Smartclick connectors Improved shield for EtherCAT communications	Standard type Cable with connectors on both ends (M12 straight/M12 straight) 	OMRON	Black	0.5	XS5W-T421-BM2-SS
						1	XS5W-T421-CM2-SS
						2	XS5W-T421-DM2-SS
						3	XS5W-T421-EM2-SS
						5	XS5W-T421-GM2-SS
			10			XS5W-T421-JM2-SS	
			Rugged type Cable with connectors on both ends (M12 straight/RJ45) 			0.5	XS5W-T421-BMCSS
						1	XS5W-T421-CMC-SS
						2	XS5W-T421-DMC-SS
						3	XS5W-T421-EMC-SS
	5	XS5W-T421-GMC-SS					
	Ethernet/ EtherCAT patch cable	Cat 6a, AWG27, 4-pair cable Cable sheath material: LSZH <sup>1</sup>  <b>Note:</b> This cable is available in yellow, green and blue colours. 	Standard type Cable with connectors on both ends (RJ45/RJ45)	OMRON	Yellow	0.2	XS6W-6LSZH8SS20CM-Y
						0.3	XS6W-6LSZH8SS30CM-Y
						0.5	XS6W-6LSZH8SS50CM-Y
						1	XS6W-6LSZH8SS100CM-Y
						1.5	XS6W-6LSZH8SS150CM-Y
						2	XS6W-6LSZH8SS200CM-Y
						3	XS6W-6LSZH8SS300CM-Y
						5	XS6W-6LSZH8SS500CM-Y
						7.5	XS6W-6LSZH8SS750CM-Y
						10	XS6W-6LSZH8SS1000CM-Y
		15	XS6W-6LSZH8SS1500CM-Y				
		20	XS6W-6LSZH8SS2000CM-Y				
		Green	Cat 5e, AWG26, 4-pair cable Cable sheath material: PUR <sup>1</sup> 		Standard type Cable with connectors on both ends (RJ45/RJ45)	0.2	XS6W-6LSZH8SS20CM-G
						0.3	XS6W-6LSZH8SS30CM-G
						0.5	XS6W-6LSZH8SS50CM-G
						1	XS6W-6LSZH8SS100CM-G
						1.5	XS6W-6LSZH8SS150CM-G
						2	XS6W-6LSZH8SS200CM-G
						3	XS6W-6LSZH8SS300CM-G
5						XS6W-6LSZH8SS500CM-G	
7.5	XS6W-6LSZH8SS750CM-G						
10	XS6W-6LSZH8SS1000CM-G						
15	XS6W-6LSZH8SS1500CM-G						
20	XS6W-6LSZH8SS2000CM-G						
Green	Cat 5e, AWG26, 4-pair cable Cable sheath material: PUR <sup>1</sup> 	Standard type Cable with connectors on both ends (RJ45/RJ45)	0.5	XS6W-5PUR8SS50CM-G			
			1	XS6W-5PUR8SS100CM-G			
			1.5	XS6W-5PUR8SS150CM-G			
			2	XS6W-5PUR8SS200CM-G			
			3	XS6W-5PUR8SS300CM-G			
			5	XS6W-5PUR8SS500CM-G			
			7.5	XS6W-5PUR8SS750CM-G			
			10	XS6W-5PUR8SS1000CM-G			
			15	XS6W-5PUR8SS1500CM-G			
			20	XS6W-5PUR8SS2000CM-G			
Grey	Cat 5e, AWG22, 2-pair cable 	Rugged type Cable with connectors on both ends (RJ45/RJ45)	0.3	XS5W-T421-AMD-K			
			0.5	XS5W-T421-BMD-K			
			1	XS5W-T421-CMD-K			
			2	XS5W-T421-DMD-K			
			3	XS5W-T421-EMD-K			
			5	XS5W-T421-GMD-K			
			10	XS5W-T421-JMD-K			
15	XS5W-T421-KMD-K						

Symbol	Item		Manufacturer	Colour	Cable length (m)	Model				
⑤	Ethernet/ EtherCAT patch cable	Cat 5e, AWG22, 2-pair cable	Rugged type Cable with connectors on both ends (M12 straight/RJ45)	OMRON	Grey	0.3	XS5W-T421-AMC-K			
						0.5	XS5W-T421-BMC-K			
						1	XS5W-T421-CMC-K			
						2	XS5W-T421-DMC-K			
						3	XS5W-T421-EMC-K			
						5	XS5W-T421-GMC-K			
						10	XS5W-T421-JMC-K			
						15	XS5W-T421-KMC-K			
						Rugged type Cable with connectors on both ends (M12 L right angle/RJ45)	OMRON	Grey	0.3	XS5W-T422-AMC-K
									0.5	XS5W-T422-BMC-K
		1	XS5W-T422-CMC-K							
		2	XS5W-T422-DMC-K							
		3	XS5W-T422-EMC-K							
		Ethernet installation cable	Cat 5, SF/UTP, 4 × 2 × AWG 24/1 (solid core), Polyurethane (PUR)	Weidmüller	Green	100	WM IE-5IC4x2xAWG24/1-PUR			
						Cat 5, SF/UTP, 4 × 2 × AWG 26/7 (stranded core), Polyurethane (PUR)	Green	100	WM IE-5IC4x2xAWG26/7-PUR	
Connectors	RJ45 metallic connector For AWG22 to AWG26		Weidmüller	-	-	WM IE-T0-RJ45-FH-BK				
	RJ45 plastic connector For AWG22 to AWG24					OMRON	-	-	XS6G-T421-1	
RJ45 socket	DIN-rail mount socket to terminate installation cable in the cabinet		Weidmüller	-	-	WM IE-T0-RJ45-FJ-B				

\*1 The lineup features low smoke zero halogen cables for in-cabinet use and PUR cables for out-of-cabinet use.



**Note:** Please be careful while cable processing, for EtherCAT, connectors on both ends should be shield connected and for EtherNet/IP, connectors on only one end should be shield connected.

**WE70 FA wireless LAN units**

Name	Area	Type	Model	Appearance
WE70 FA wireless LAN units	Europe	Access point (Master)	WE70-AP-EU	
		Client (Slave)	WE70-CL-EU	
Directional magnetic-base antenna		1 set with two antennas, 2.4 GHz/5 GHz Dual-band compatible	WE70-AT001H	
DIN rail mounting bracket		For TH35 7.5	WT30-FT001	
		For TH35 15	WT30-FT002	
Antenna extension cable		5 m	WE70-CA5M	

**Note:** Special versions are available for USA, Canada, China and Japan.

**Accessories**

Specifications	Model	Appearance
SD memory card	2 GB	
	4 GB	
DIN track	Length: 0.5 m; height: 7.3 mm	PFP-50N
	Length: 1 m; height: 7.3 mm	PFP-100N
	Length: 1 m; height: 16 mm	PFP-100N2
Battery for NX7/NJ CPU unit (The battery is included with the CPU unit)	CJ1W-BAT01	
End cover (The end cover is included with the CPU unit. Necessary to be connected to the right end of the CPU rack)	NX-END01	
Fan unit (The fan unit is included with the CPU unit)	NX-FAN01	

**Computer software**

Symbol	Specifications	Model
⑥	Sysmac Studio version 1.13 or higher	SYSMAC-SE2□□□ <sup>*1</sup>

\*1 Refer to the Sysmac Studio datasheet (Cat. No. SysCat\_I181E) for detailed information or contact your OMRON representative.

ALL DIMENSIONS SHOWN ARE IN MILLIMETERS.  
To convert millimeters into inches, multiply by 0.03937. To convert grams into ounces, multiply by 0.03527.

Cat. No. SysCat\_I186E-EN-01B In the interest of product improvement, specifications are subject to change without notice.



# SCATTERGOOD & JOHNSON LTD

ELECTRICAL ENGINEERING & FLUID CONTROL DISTRIBUTORS

Est.1899

At Scattergood & Johnson Ltd, we pride ourselves on being a technical distributor to specialist industries.

Working with a range of quality product suppliers across a number of specialist markets, we are not your average 'box shifter' - we are your technical and supply chain partner.

We fully support every product we sell - for free! Our internal team and external sales engineers can answer any product or application question, no matter the complexity.

Backing up this technical ability is a range of 50,000+ products available from stock for nationwide next day delivery (same day if required!), or you can collect what you need from any of our trade counters around the UK.

Select your specialist interest below to learn more about how we can help.



Online, In Branch and On the Road - Scattergood & Johnson Ltd, there when you need us.

# [www.scatts.co.uk](http://www.scatts.co.uk)