

R88D-1SN□□□-ECT

# 1S servo drive

## Sysmac general purpose servo

- 23-bit resolution encoder
- Fast and secure screw-less push-in in all connectors
- Pluggable connectors for easy pre-wiring and system maintenance
- Direct wiring of I/O signals
- Embedded relay for direct motor brake control
- Improved loop control for overshoot and quick setting time
- Safety function built-in:  
 Network Safe Torque Off: PLd (EN ISO 13849-1), SIL2 (IEC 61508)  
 Hardwired Safe Torque Off: PLe (EN ISO 13849-1), SIL3 (IEC 61508)



## Ratings

- 230 VAC single-phase: 100 W to 1.5 kW
- 400 VAC three-phase: 600 W to 15 kW

## System configuration

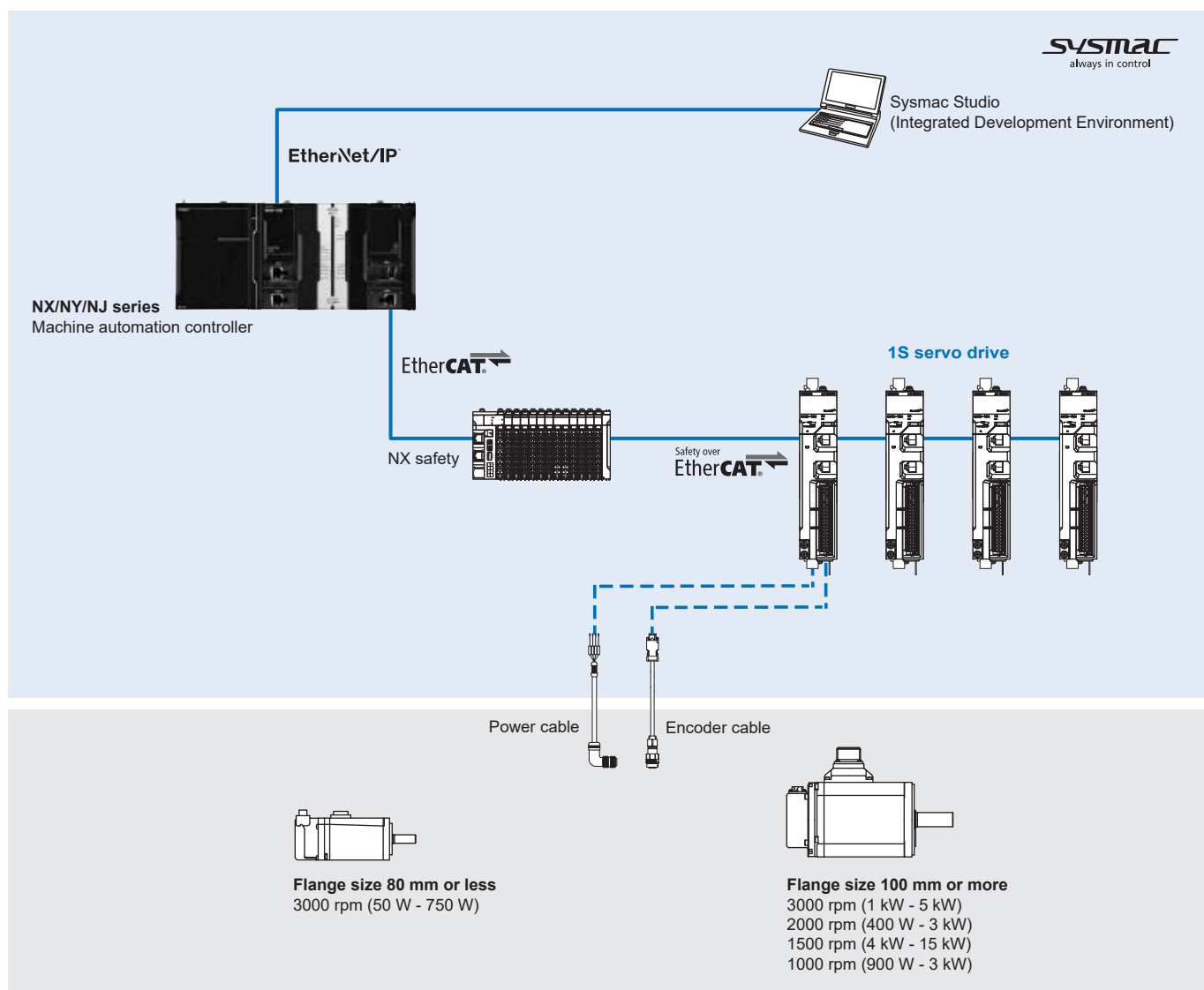

Type designation

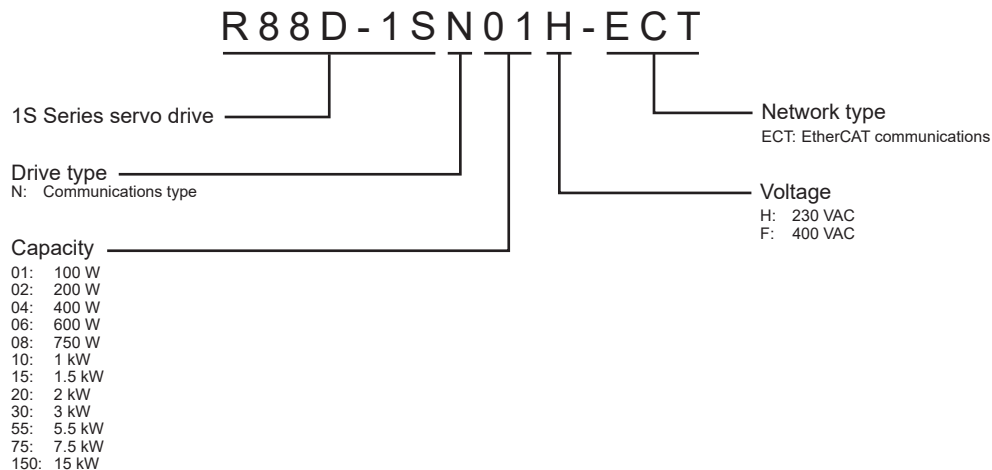

Specifications

Single-phase, 230 V

| Servo drive model              |                                       |                              | R88D-1SN01H-ECT  | R88D-1SN02H-ECT                            | R88D-1SN04H-ECT   | R88D-1SN08H-ECT   | R88D-1SN15H-ECT                        |
|--------------------------------|---------------------------------------|------------------------------|--|--|-------------------|-------------------|--|
| Applicable servo motor         | 3000 r/min                            |                              | R88M-1M05030T<br>R88M-1M10030(H/T)   | R88M-1M20030(H/T)                          | R88M-1M40030(H/T) | R88M-1M75030(H/T) | R88M-1L1K030(H/T)<br>R88M-1L1K530(H/T) |
|                                | 2000 r/min                            |                              | -  | -  | -                 | -                 | R88M-1M1K020(H/T)<br>R88M-1M1K520(H/T) |
|                                | 1000 r/min                            |                              | -  | -  | -                 | -                 | R88M-1M90010T                          |
| Max. applicable motor capacity |                                       | W                            | 100  | 200  | 400               | 750               | 1500                                   |
| Input                          | Control circuit                       | Power supply voltage         | V  | 24 VDC (21.6 to 26.4 V)                    |                   |                   |  |
|                                | Main circuit                          | Power supply voltage         | V  | Single-phase 200 to 240 VAC (170 to 252 V) |                   |                   |  |
|                                |                                       | Frequency                    | Hz   | 50/60 Hz (47.5 to 63 Hz)                   |                   |                   |  |
| Rated input current            | Single-phase                          | Arms                         | 1.8  | 2.7  | 4.6               | 7.3               | 15.7                                   |
| Output                         | Rated output current                  | Arms                         | 0.8  | 1.5  | 2.5               | 4.6               | 9.7                                    |
|                                | Max. current                          | Arms                         | 3.1  | 5.6  | 9.1               | 16.9              | 28.4                                   |
| Basic                          | Ambient operating/storage temperature |                              | 0 to 55°C/-20 to 65°C  |  |                   |                   |  |
|                                | Ambient operating/storage humidity    |                              | 90% RH or less (without condensation)  |  |                   |                   |  |
|                                | Atmosphere                            |                              | Must be free from corrosive gases  |  |                   |                   |  |
|                                | Altitude                              |                              | 1000 m or less   |  |                   |                   |  |
|                                | Vibration resistance (max.)           |                              | 5.88 m/s <sup>2</sup> , 10 to 60 Hz (continuous operation at resonance point is not allowed) |  |                   |                   |  |
| Degree of protection           |                                       | IP20 (Built into IP54 panel) |  |  |                   |                   |  |
| Weight                         | kg                                    | 1.2                          | 1.2  | 1.5  | 2.0               | 3.4               |  |

## Three-phase, 400 V

| Servo drive model              |                                       |                      | R88D-1SN06F-ECT  | R88D-1SN10F-ECT                           | R88D-1SN15F-ECT | R88D-1SN20F-ECT |      |
|--------------------------------|---------------------------------------|----------------------|--|---|-----------------|-----------------|------|
| Applicable servo motor         | 3000 r/min                            |                      | -  | R88M-1L75030C<br>R88M-1L1K030C            | R88M-1L1K530C   | R88M-1L2K030C   |      |
|                                | 2000 r/min                            |                      | R88M-1M40020C<br>R88M-1M60020C   | R88M-1M1K020C                             | R88M-1M1K520C   | R88M-1M2K020C   |      |
|                                | 1000 r/min                            |                      | -  | R88M-1M90010C                             | -               | R88M-1M2K010C   |      |
| Max. applicable motor capacity |                                       |                      | W  | 600                                       | 1000            | 1500            | 2000 |
| Input                          | Control circuit                       | Power supply voltage | V  | 24 VDC (21.6 to 26.4 V)                   |                 |                 |      |
|                                | Main circuit                          | Power supply voltage | V  | Three-phase 380 to 480 VAC (323 to 504 V) |                 |                 |      |
|                                |                                       | Frequency            | Hz   | 50/60 Hz (47.5 to 63 Hz)                  |                 |                 |      |
|                                | Rated input current                   | Three-phase          | Arms   | 2.4                                       | 3.1             | 4.3             | 6.5  |
| Output                         | Rated output current                  |                      | Arms   | 1.8                                       | 4.1             | 4.7             | 7.8  |
|                                | Max. current                          |                      | Arms   | 5.5                                       | 9.6             | 14.1            | 19.8 |
| Basic                          | Ambient operating/storage temperature |                      | 0 to 55°C/-20 to 65°C  |   |                 |                 |      |
|                                | Ambient operating/storage humidity    |                      | 90% RH or less (without condensation)  |   |                 |                 |      |
|                                | Atmosphere                            |                      | Must be free from corrosive gases  |   |                 |                 |      |
|                                | Altitude                              |                      | 1000 m or less   |   |                 |                 |      |
|                                | Vibration resistance (max.)           |                      | 5.88 m/s <sup>2</sup> , 10 to 60 Hz (continuous operation at resonance point is not allowed) |   |                 |                 |      |
| Degree of protection           |                                       |                      | IP20 (Built into IP54 panel)   |   |                 |                 |      |
| Weight                         |                                       |                      | kg   | 3.4                                       | 3.4             | 3.4             | 3.4  |

| Servo drive model              |                                       |                      | R88D-1SN30F-ECT  | R88D-1SN55F-ECT                           | R88D-1SN75F-ECT | R88D-1SN150F-ECT                     |       |
|--------------------------------|---------------------------------------|----------------------|--|---|-----------------|--------------------------------------|-------|
| Applicable servo motor         | 3000 r/min                            |                      | R88M-1L3K030C  | R88M-1L4K030C-□<br>R88M-1L5K030C-□        | -               | -                                    |       |
|                                | 2000 r/min                            |                      | R88M-1M3K020C  | -   | -               | -                                    |       |
|                                | 1500 r/min                            |                      | -  | R88M-1M4K015C-□<br>R88M-1M5K515C-□        | R88M-1M7K515C-□ | R88M-1M11K015C-□<br>R88M-1M15K015C-□ |       |
|                                | 1000 r/min                            |                      | R88M-1M3K010C  | -   | -               | -                                    |       |
| Max. applicable motor capacity |                                       |                      | W  | 3000                                      | 5500            | 7500                                 | 15000 |
| Input                          | Control circuit                       | Power supply voltage | V  | 24 VDC (21.6 to 26.4 V)                   |                 |                                      |       |
|                                | Main circuit                          | Power supply voltage | V  | Three-phase 380 to 480 VAC (323 to 504 V) |                 |                                      |       |
|                                |                                       | Frequency            | Hz   | 50/60 Hz (47.5 to 63 Hz)                  |                 |                                      |       |
|                                | Rated input current                   | Three-phase          | Arms   | 8.4                                       | 16              | 23                                   | 40    |
| Output                         | Rated output current                  |                      | Arms   | 11.3                                      | 14.5            | 22.6                                 | 33.9  |
|                                | Max. current                          |                      | Arms   | 28.3                                      | 42.4            | 56.5                                 | 84.8  |
| Basic                          | Ambient operating/storage temperature |                      | 0 to 55°C/-20 to 65°C  |   |                 |                                      |       |
|                                | Ambient operating/storage humidity    |                      | 90% RH or less (without condensation)  |   |                 |                                      |       |
|                                | Atmosphere                            |                      | Must be free from corrosive gases  |   |                 |                                      |       |
|                                | Altitude                              |                      | 1000 m or less   |   |                 |                                      |       |
|                                | Vibration resistance (max.)           |                      | 5.88 m/s <sup>2</sup> , 10 to 60 Hz (continuous operation at resonance point is not allowed) |   |                 |                                      |       |
| Degree of protection           |                                       |                      | IP20 (Built into IP54 panel)   |   |                 |                                      |       |
| Weight                         |                                       |                      | kg   | 3.4                                       | 9.4             | 9.4                                  | 21    |

## I/O specifications

## Control I/O and safety connector (CN1)

| Pin No. | Signal name | Function                                     | Pin No. | Signal name | Function                                   |   |
|---------|-------------|--|---------|-------------|--|---|
| 1       | EDM+P       | EDM+ output with short-circuit protection    | 21      | EDM-        | EDM- output                                | A monitor signal is output to detect a safety function failure. The Pin No. 22 is reserved.   |
| 2       | EDM+        | EDM+ output without short-circuit protection | 22      | SFA         | Reserved                                   |   |
| 3       | SF1+        | SF1+ input                                   | 23      | SF1+        | SF1+ input                                 | Inputs 1 and 2 for operating the STO function, which are two independent circuits. This input turns OFF the power transistor drive signals in the servo drive to cut off the current output to the motor.   |
| 4       | SF1-        | SF1- input                                   | 24      | SF1-        | SF1- input                                 |   |
| 5       | SF2+        | SF2+ input                                   | 25      | SF2+        | SF2+ input                                 |   |
| 6       | SF2-        | SF2- input                                   | 26      | SF2-        | SF2- input                                 |   |
| 7       | SFB         | Reserved                                     | 27      | NC          | NC   | Reserved. Do not connect.   |
| 8       | /ERR+       | Error output                                 | 28      | /ERR-       | Error output common                        | If the servo drive detects an abnormality, it outputs an error (/ALM) and turns OFF the power drive circuit.  |
| 9       | OUT1+       | General-purpose output 1                     | 29      | OUT1-       | General-purpose output 1 common            | Output functions: Error output (ERR), Servo ready completed output (READY), Positioning completion output 1/2 (INP1/INP2), Motor rotation speed detection output (TGON), Torque limit output (TLMT), Zero speed detection output (ZSP), Speed conformity output (VCMP), Warning output 1/2 (WARN1/WARN2), Speed limiting output (VLIMIT), Error clear attribute output (ERR-ATB), Remote output 1/2/3 (R-OUT1/R-OUT2/R-OUT3), Zone notification output 1/2 (ZONE1/ZONE2), Position command status output (PCMD), Distribution completed output (DEN). |
| 10      | OUT2+       | General-purpose output 2                     | 30      | OUT2-       | General-purpose output 2 common            |   |
| 11      | OUT3+       | General-purpose output 3                     | 31      | OUT3-       | General-purpose output 3 common            |   |
| 12      | IN1         | General-purpose input 1                      | 32      | IN2         | General-purpose input 2                    | Input functions: Positive drive prohibition input (POT), Negative drive prohibition input (NOT), Error stop input (ESTP), External latch input 1/2 (EXT1/EXT2), Home proximity input (DEC), Positive torque limit input (PCL), Negative torque limit input (NCL), Monitor input 1/2/3/4/5/6/7/8 (MON1/MON2/MON3/MON4/MON5/MON6/MON7/MON8), Main circuit power supply ON/OFF input (PRDY).   |
| 13      | IN3         | General-purpose input 3                      | 33      | IN4         | General-purpose input 4                    |   |
| 14      | IN5         | General-purpose input 5                      | 34      | IN6         | General-purpose input 6                    |   |
| 15      | IN7         | General-purpose input 7 (high-speed input)   | 35      | IN8         | General-purpose input 8 (high-speed input) |   |
| 16      | GND         | Encoder GND                                  | 36      | Common      | 12 to 24 VDC power supply                  |   |
| 17      | A+          | Encoder phase A+ output                      | 37      | A-          | Encoder phase A- output                    | Encoder signal output.  |
| 18      | B+          | Encoder phase B+ output                      | 38      | B-          | Encoder phase B- output                    | Line Drive output.  |
| 19      | Z+          | Encoder phase Z+ output                      | 39      | Z-          | Encoder phase Z- output                    | EIARS422A compliant (load resistance: 120 Ω).<br>Max. output frequency: 4 Mpps (when multiplied by 4).  |
| 20      | FG          | FG   | 40      | FG          | FG   | Frame ground.   |

## Encoder connector (CN2)

| Pin No. | Signal name | Function                     |                               |
|---------|-------------|------------------------------|-------------------------------|
| 1       | E5V         | Encoder power supply voltage | Encoder power supply voltage. |
| 2       | E0V         | Encoder power supply GND     |                               |
| 3       | NC          | Not used                     | Not used.                     |
| 4       | NC          | Not used                     |                               |
| 5       | PS+         | Encoder+ phase-S I/O         | Encoder phase-S I/O.          |
| 6       | PS-         | Encoder- phase-S I/O         |                               |
| Shell   | FG          | Frame ground                 | Frame ground.                 |

## USB connector (CN7)

| Pin No. | Signal name | Function            |                                   |
|---------|-------------|---------------------|-----------------------------------|
| 1       | VBUS        | USB signal terminal | Used for computer communications. |
| 2       | D-          |                     |                                   |
| 3       | D+          |                     |                                   |
| 4       | Reserved    | Reserved            | Reserved. Do not connect.         |
| 5       | GND         | Signal ground       | Signal ground.                    |

## Brake interlock connector (CN12)

| Pin No. | Signal name | Function                      |                              |
|---------|-------------|-------------------------------|------------------------------|
| 1       | 0V_BKIR     | 24 V power supply for brake - | 24 V power supply for brake. |
| 2       | +24V_BKIR   | 24 V power supply for brake + |                              |
| 3       | BKIR-       | Brake output -                | Brake output.                |
| 4       | BKIR+       | Brake output +                |                              |

**I/O specifications (specific for 230 V, 100 W to 750 W models)****Main circuit connector (CNA)**

| Pin No. | Signal name | Function  |  |
|---------|-------------|---|--|
| 1       | L1          | Main circuit power supply input                     | Input for the main circuit power supply voltage.<br>Single-phase 200 to 240 VAC (170 to 252 V), 50/60 Hz <sup>*1</sup>   |
| 2       | L2          |   |  |
| 3       | L3          |   |  |
| 4       | B3          | External regeneration resistor connection terminals | If regenerative energy is high, an external regeneration resistor is connected so that the regenerative energy can be absorbed.<br>When an internal regeneration resistor is used:<br>B1 and B2 are open, B2 and B3 are short-circuited <sup>*2</sup> .<br>When an external regeneration resistor is used:<br>The external regeneration resistor is connected between B1 and B2, B2 and B3 are open. |
| 5       | B2          |   |  |
| 6       | P/B1        |   |  |
| 7       | N1          | DC reactor connection terminals                     | When the DC reactor is not used, short-circuit N1 and N2.<br>When the DC reactor is used, connect the DC reactor between N1 and N2.  |
| 8       | N2          |   |  |
| 9       | N3          |   |  |
| 10      | +24V        | Control circuit power supply input                  | Input for the control power supply voltage.<br>24 VDC $\pm$ 10% (21.6 to 26.4 V)<br>Measured current value: 600 mA   |
| 11      | 0V          |   |  |

\*1 When the single-phase input is used, connect between any two phases out of the following: L1, L2 and L3.

\*2 B2 and B3 shall be short-circuited in the factory setting.

**Motor connector (CNC)**

| Pin No. | Signal name | Function                   |  |
|---------|-------------|----------------------------|--|
| 1       | U           | Motor connection terminals | These are the connection terminals to the servo motor. |
| 2       | V           |                            |  |
| 3       | W           |                            |  |

**I/O specifications (specific for 230 V, 1.5 kW model / 400 V, 600 W to 3 kW models)****Main circuit connector A (CNA)**

| Pin No. | Signal name | Function  |  |
|---------|-------------|---|--|
| 1       | B1          | External regeneration resistor connection terminals | If regenerative energy is high, an external regeneration resistor is connected so that the regenerative energy can be absorbed.<br>When an internal regeneration resistor is used:<br>B1 and B2 are open, B2 and B3 are short-circuited <sup>*1</sup> .<br>When an external regeneration resistor is used:<br>The external regeneration resistor is connected between B1 and B2, B2 and B3 are open. |
| 2       | B2          |   |  |
| 3       | B3          |   |  |
| 4       | L3          | Main circuit power supply input                     | Input for the main circuit power supply voltage.<br>Single-phase 200 to 240 VAC (170 to 252 V), 50/60 Hz <sup>*2</sup><br>Three-phase 380 to 480 VAC (323 to 504 V), 50/60 Hz  |
| 5       | L2          |   |  |
| 6       | L1          |   |  |

\*1 B2 and B3 shall be short-circuited in the factory setting.

\*2 When the single-phase input is used, connect between any two phases out of the following: L1, L2 and L3.

**Main circuit connector B (CNB)**

| Pin No. | Signal name | Function                        |   |
|---------|-------------|---------------------------------|---|
| 1       | N3          | DC reactor connection terminals | When the DC reactor is not used, short-circuit N1 and N2.<br>When the DC reactor is used, connect the DC reactor between N1 and N2. |
| 2       | N2          |                                 |   |
| 3       | N1          |                                 |   |
| 4       | P           |                                 |   |

**Motor connector (CNC)**

| Pin No. | Signal name | Function                   |  |
|---------|-------------|----------------------------|--|
| 1       | W           | Motor connection terminals | These are the connection terminals to the servo motor. |
| 2       | V           |                            |  |
| 3       | U           |                            |  |
| 4       | FG          |                            |  |

**Control circuit connector (CND)**

| Pin No. | Signal name | Function                           |  |
|---------|-------------|------------------------------------|--|
| 1       | +24V        | Control circuit power supply input | Input for the control power supply voltage.<br>24 VDC $\pm$ 10% (21.6 to 26.4 V)<br>Measured current value: 900 mA |
| 2       | 0V          |                                    |  |
| 3       | NC          | -                                  |  |

## I/O specifications (specific for 400 V, 5.5 kW to 7.5 kW models)

## Main circuit connector A (CNA)

| Pin No. | Signal name | Function  |   |
|---------|-------------|---|---|
| 1       | L1          | Main circuit power supply input                     | 3-phase 380 to 480 VAC (323 to 504 VAC) 50/60 Hz (47.5 to 63 Hz)  |
| 2       | L2          |   |   |
| 3       | L3          |   |   |
| 4       | B3          | External regeneration resistor connection terminals | When the internal regeneration resistor is used, open between B1 and B2, short-circuit B2 and B3.<br>When the external regeneration resistor is used, connect the external regeneration resistor between B1 and B2, open between B2 and B3. |
| 5       | B2          |   |   |
| 6       | B1          |   |   |

## Main circuit connector B (CNB)

| Pin No. | Signal name | Function                        |   |
|---------|-------------|---------------------------------|---|
| 1       | P           | DC reactor connection terminals | When the DC reactor is not used, short-circuit N1 and N2.<br>When the DC reactor is used, connect the DC reactor between N1 and N2. |
| 2       | N1          |                                 |   |
| 3       | N2          |                                 |   |
| 4       | N3          |                                 |   |

## Motor connector (CNC)

| Pin No. | Signal name | Function                   |  |
|---------|-------------|----------------------------|--|
| 1       | FG          | Motor connection terminals | These are output terminals to the Servomotor.<br>Be sure to wire them correctly. |
| 2       | U           |                            |  |
| 3       | V           |                            |  |
| 4       | W           |                            |  |

## Control circuit connector (CND)

| Pin No. | Signal name | Function                           |   |
|---------|-------------|------------------------------------|---|
| 1       | +24 V       | Control circuit power supply input | 24 VDC (21.6 to 26.4 V)<br>Measured current value: 900 mA |
| 2       | +24 V       |                                    |   |
| 3       | 0 V         |                                    |   |
| 4       | 0V          |                                    |   |

## Main circuit connector E (CNE)

| Pin No. | Signal name | Function   |  |
|---------|-------------|--|--|
| 1       | DB1         | External dynamic brake resistor connection terminals | When the internal dynamic brake resistor is used, open between DB1 and DB2, short-circuit DB2 and DB3.<br>When the external dynamic brake resistor is used, connect the external dynamic brake resistor between DB1 and DB2, open between DB2 and DB3. |
| 2       | DB2         |  |  |
| 3       | DB3         |  |  |

## I/O specifications (specific for 400 V, 15 kW model)

## Main circuit connector A (CNA)

| Pin No. | Signal name   | Function                        |  |
|---------|---|---------------------------------|--|
| 1       | P   | -                               | Do not connect.  |
| 2       | N3  |                                 |  |
| 3       | L3  | Main circuit power supply input | 3-phase 380 to 480 VAC (323 to 504 VAC) 50/60 Hz (47.5 to 63 Hz) |
| 4       | L2  |                                 |  |
| 5       | L1  |                                 |  |
| 6       |  |                                 |  |

## Main circuit connector B (CNB)

| Pin No. | Signal name | Function  |   |
|---------|-------------|---|---|
| 1       | B1          | External regeneration resistor connection terminals | Connect the external regeneration resistor between B1 and B2. This Servo Drive does NOT install internal regeneration resistor. |
| 2       | B2          |   |   |

## Motor connector (CNC)

| Pin No. | Signal name | Function                   |   |
|---------|-------------|----------------------------|---|
| 1       | FG          | Motor connection terminals | These are output terminals to the Servomotor. Be sure to wire them correctly. |
| 2       | U           |                            |   |
| 3       | V           |                            |   |
| 4       | W           |                            |   |

## Control circuit connector (CND)

| Pin No. | Signal name | Function                           |   |
|---------|-------------|------------------------------------|---|
| 1       | +24 V       | Control circuit power supply input | 24 VDC (21.6 to 26.4 V)<br>Measured current value: 1,200 mA |
| 2       | +24 V       |                                    |   |
| 3       | 0 V         |                                    |   |
| 4       | 0V          |                                    |   |

## Main circuit connector E (CNE)

| Pin No. | Signal name | Function   |   |
|---------|-------------|--|---|
| 1       | DB1         | External dynamic brake resistor connection terminals | When the internal dynamic brake resistor is used, open between DB1 and DB2, short-circuit DB2 and DB3. When the external dynamic brake resistor is used, connect the external dynamic brake resistor between DB1 and DB2, open between DB2 and DB3. |
| 2       | DB2         |  |   |
| 3       | DB3         |  |   |

Nomenclature

■ TOP VIEW  
(230 V, 100 W to 750 W models)

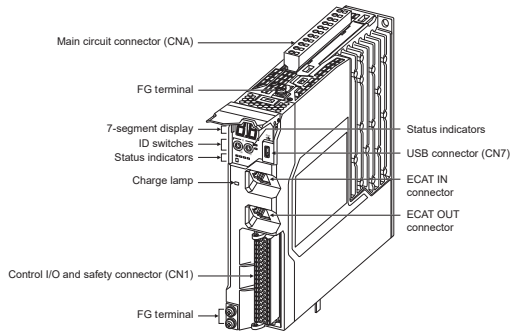

■ BOTTOM VIEW  
(230 V, 100 W to 750 W models)

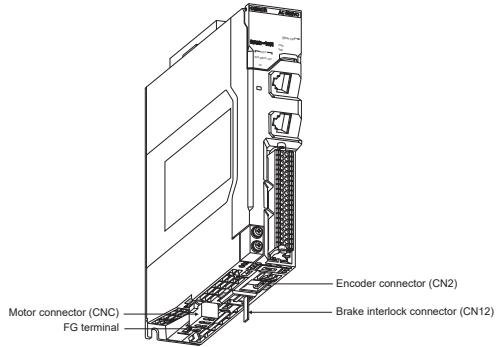

■ TOP VIEW  
(230 V, 1.5 kW model)  
(400 V, 600 W to 3 kW models)

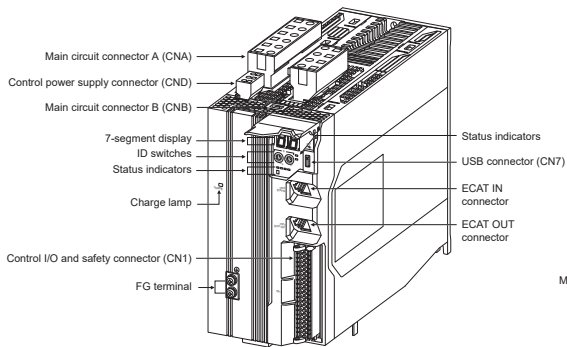

■ BOTTOM VIEW  
(230 V, 1.5 kW model)  
(400 V, 600 W to 3 kW models)

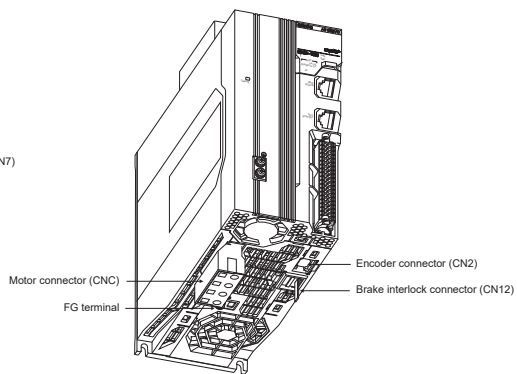

■ TOP VIEW  
(400 V, 5.5 kW to 7.5 kW models)

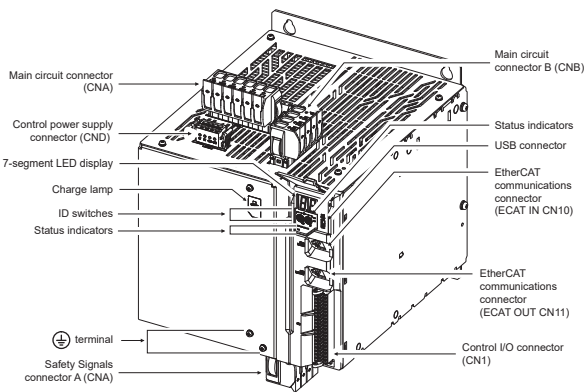

■ BOTTOM VIEW  
(400 V, 5.5 kW to 7.5 kW models)

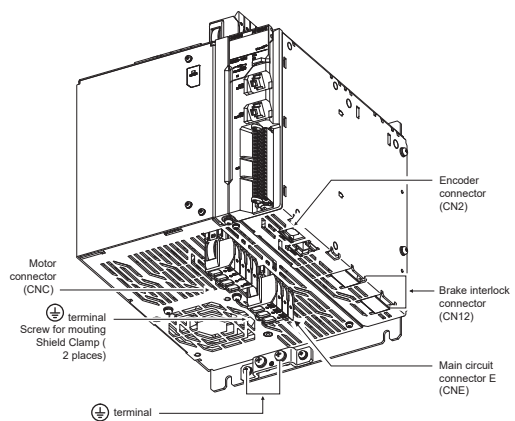

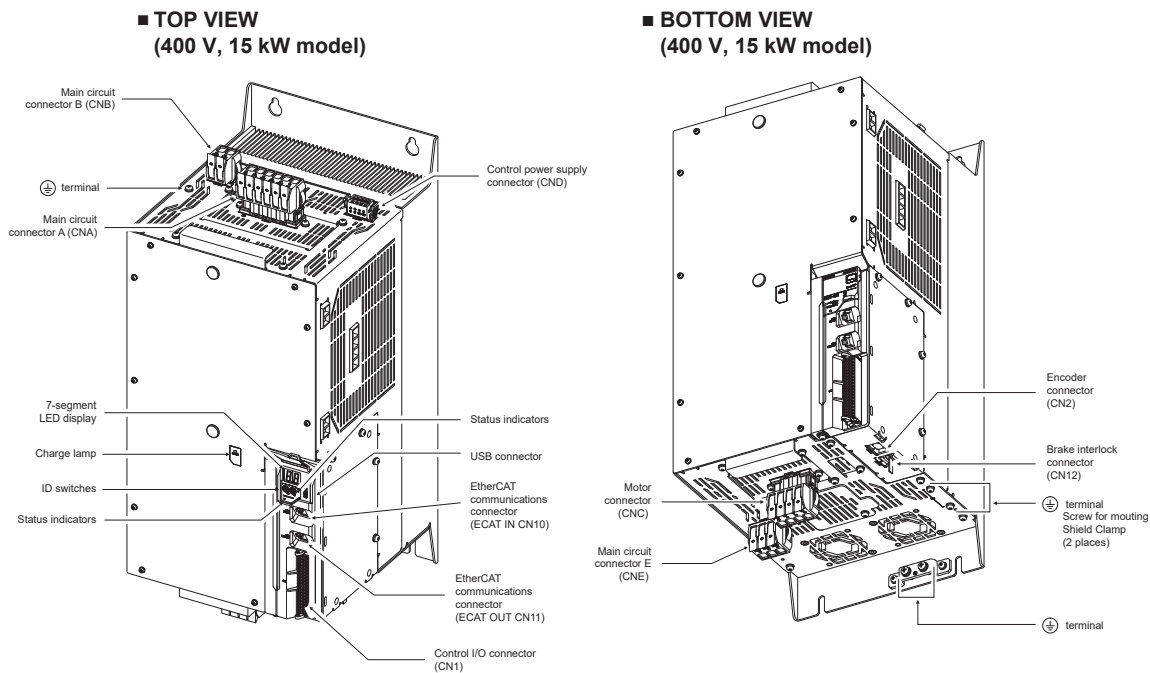

| Name   | Description   |
|--|---|
| Status indicators                            | The following seven indicators are mounted:<br>PWR (Green): Displays the status of the control power supply.<br>ERR (Red): Displays the servo drive error status.<br>ECAT-RUN (Green) and ECAT-ERR (Red): Displays the EtherCAT communications status.<br>ECAT-L/A IN (Green) and ECAT-L/A OUT (Green): Lights or flashes according to the status of a link in the EtherCAT physical layer.<br>FS (Red/Green): Displays the FSoE communications status. |
| 7-segment display                            | A 2-digit 7-segment display shows error numbers, the servo drive status and other information.  |
| ID switches                                  | Two rotary switches (0 to F hex) are used to set the EtherCAT node address.   |
| Charge lamp                                  | Lights when the main circuit power supply is turned ON.   |
| EtherCAT communications connectors           | These connectors (ECAT IN and ECAT OUT) are for EtherCAT communications.  |
| Control I/O and safety connector (CN1)       | Used for command input signals, I/O signals and the safety device connector. The short-circuit wire is installed on the safety signals before shipment.   |
| Encoder connector (CN2)                      | Connector for the encoder installed in the servo motor.   |
| USB connector (CN7)                          | USB-Micro B communications connector for the computer. This connector enables USB 2.0 Full Speed (12 Mbps) communications.  |
| Brake interlock connector (CN12)             | Used for brake interlock signals.   |
| Main circuit connector (CNA) <sup>*1</sup>   | Connector for the main circuit power supply input, control power supply input, external regeneration resistor and DC reactor.   |
| Main circuit connector A (CNA) <sup>*2</sup> | Connector for the main circuit power supply input and external regeneration resistor.   |
| Main circuit connector A (CNA) <sup>*3</sup> | Connector for the main circuit power supply input and AC reactor.   |
| Main circuit connector B (CNB) <sup>*2</sup> | Connector for a DC reactor.   |
| Main circuit connector B (CNB) <sup>*3</sup> | Connector for an external regeneration resistor.  |
| Motor connector (CNC)                        | Connector for the power line to U, V and W phases of the servo motor. The connector differs depending on the model.   |
| Control power supply connector (CND)         | Connector for control power supply input.   |
| Main circuit connector E (CNE) <sup>*4</sup> | Connector for an external dynamic brake resistor.   |
| FG terminals                                 | Terminals for FG connection.  |

<sup>\*1</sup> Specific connector for 230 V, 100 W to 750 W models.

<sup>\*2</sup> Specific connector for 230 V, 1.5 kW model and 400 V, 600 W to 7.5 kW models.

<sup>\*3</sup> Specific connector for 400 V, 15 kW model.

<sup>\*4</sup> Specific connector for 400 V, 5.5 kW to 15 kW models.

Dimensions

Servo drives

R88D-1SN01H-ECT/02H-ECT (230 V, 100 W to 200 W)

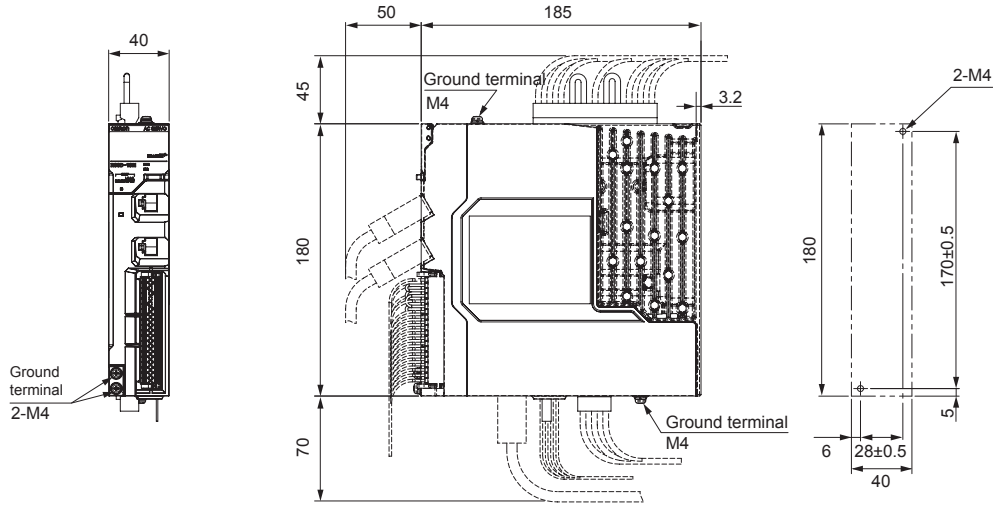

R88D-1SN04H-ECT (230 V, 400 W)

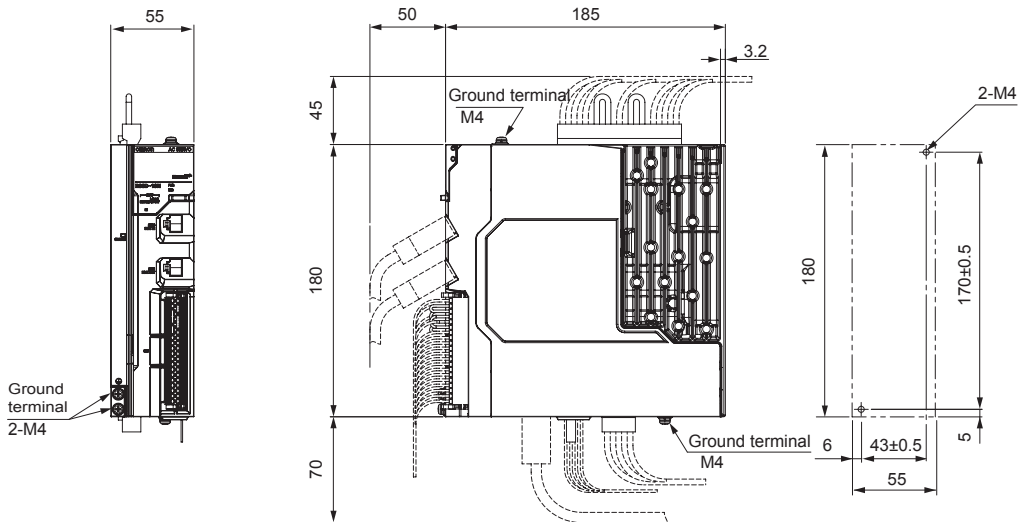

R88D-1SN08H-ECT (230 V, 750 W)

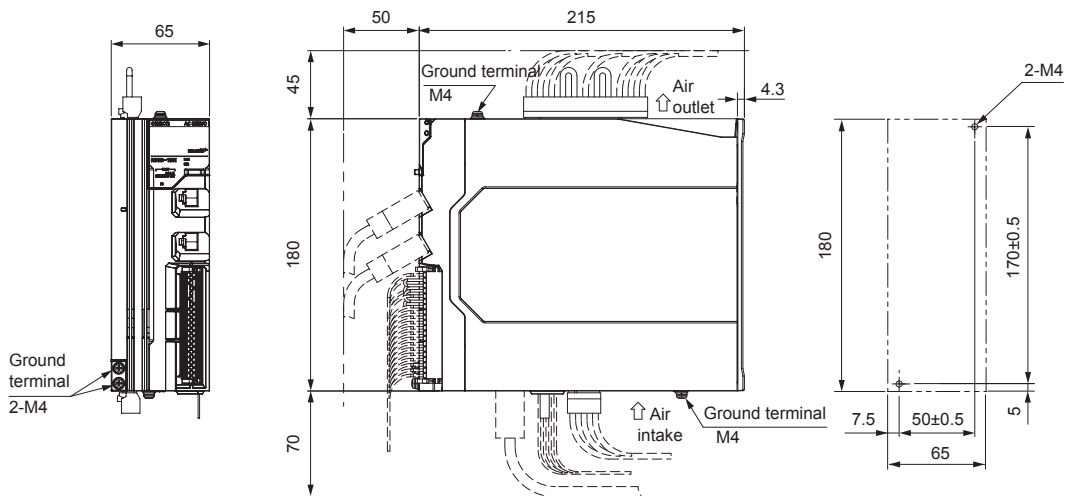

**R88D-1SN15H-ECT (230 V, 1.5 kW)**

**R88D-1SN06F-ECT/10F-ECT/15F-ECT/20F-ECT/30F-ECT (400 V, 600 W to 3 kW)**

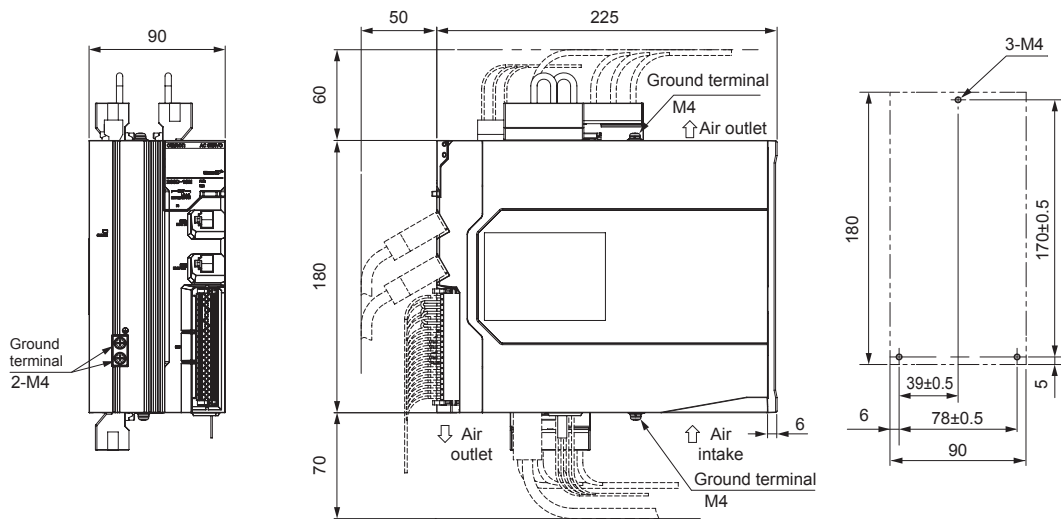

**R88D-1SN55F-ECT/75F-ECT (400 V, 5.5 kW to 7.5 kW)**

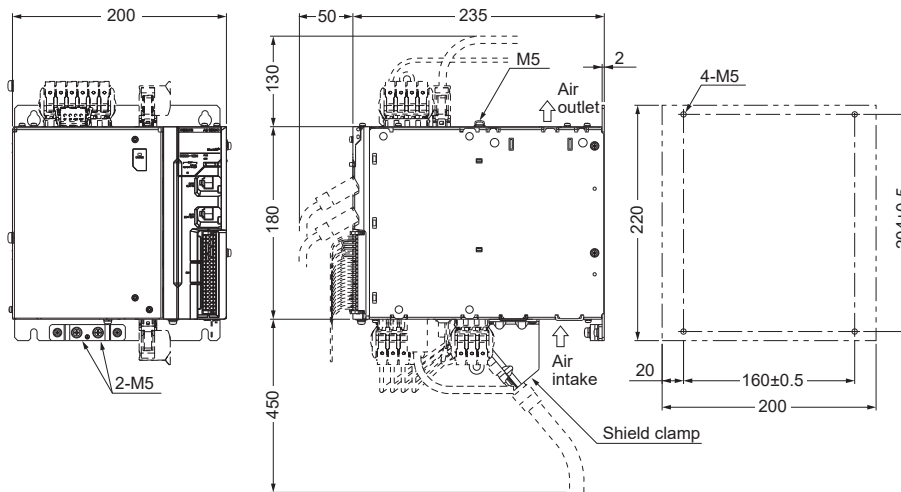

R88D-1SN150F-ECT (400 V, 15 kW)

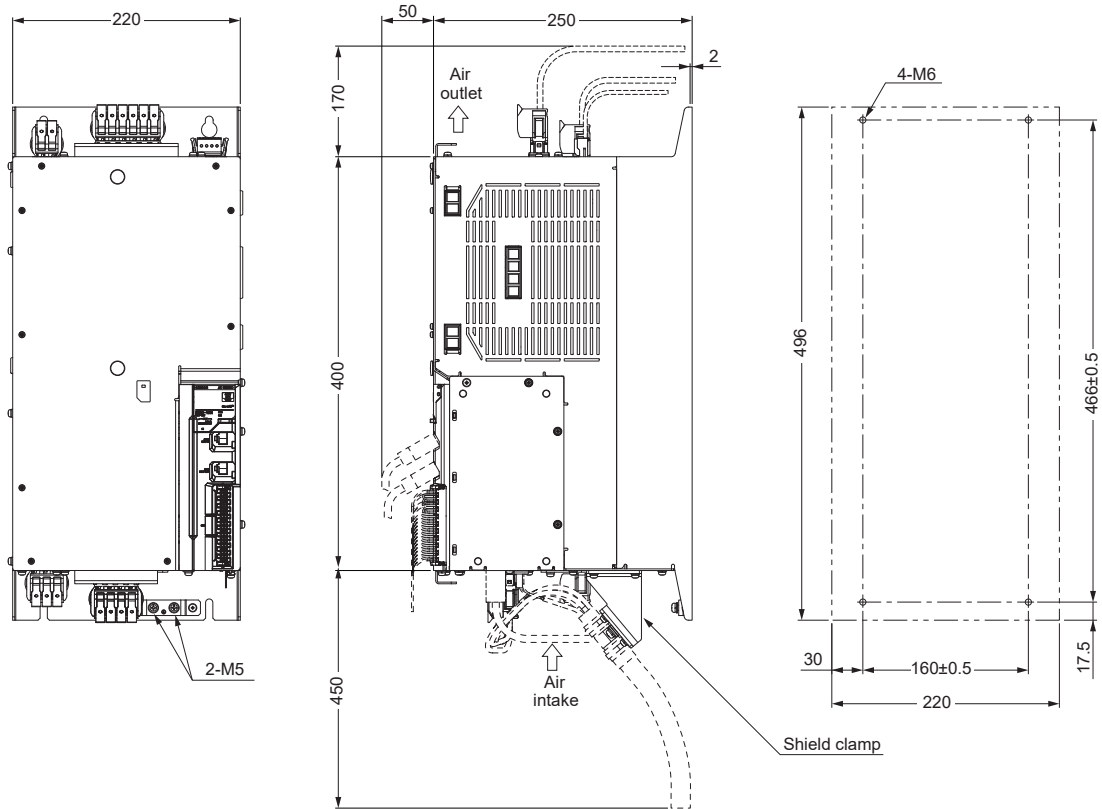

Filters

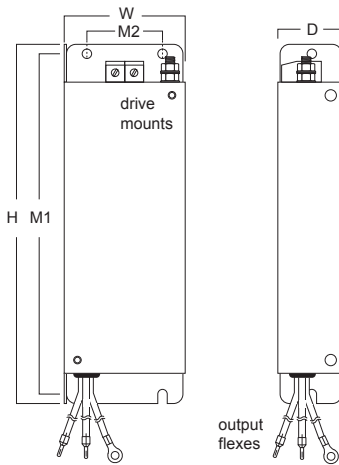

| Filter model    | External dimensions |     |    | Mount dimensions |     |
|-----------------|---------------------|-----|----|------------------|-----|
|                 | H                   | W   | D  | M1               | M2  |
| R88A-F11S103-SE | 220                 | 40  | 35 | 210              | 20  |
| R88A-F11S105-SE |                     | 55  |    |                  | 30  |
| R88A-F11S108-SE |                     | 65  |    |                  | 40  |
| R88A-F11S116-SE |                     | 90  |    |                  | 60  |
| R88A-F11S309-SE |                     |     |    |                  |     |
| R88A-F11S330-SE | 265                 | 200 | 52 | 250              | 160 |
| R88A-F11S350-SE | 545                 | 220 | 65 | 530              | 180 |

Installation

Single-phase, 230 VAC (100 W to 750 W models)

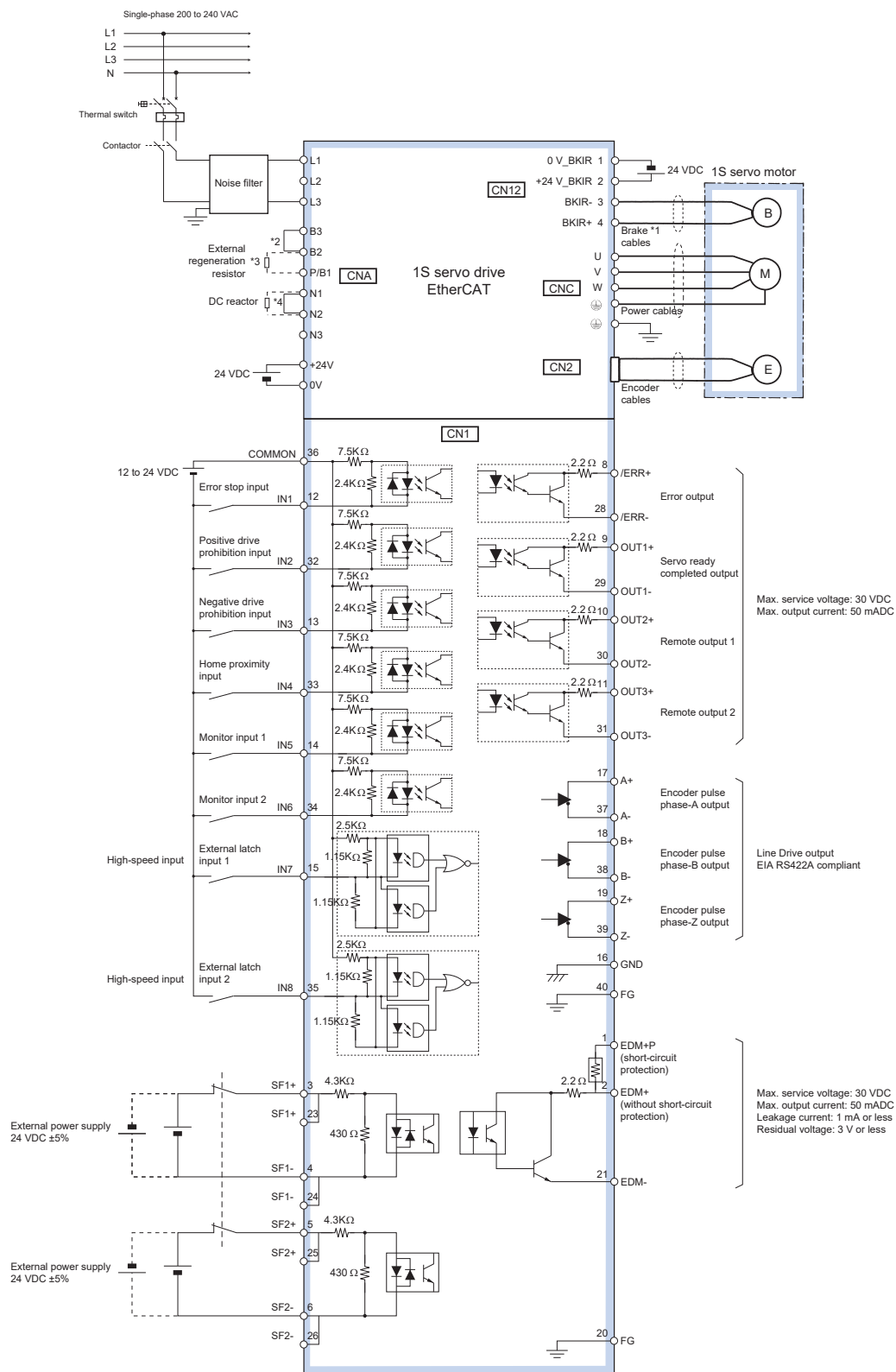

- \*1. There is no polarity on the brake.
- \*2. For 750 W servo drive, B2 and B3 are short-circuited. If the internal regenerative resistor is insufficient, remove the wire between B2 and B3 and connect an external regenerative resistor between B1 and B2.
- \*3. There is no internal regeneration resistor for 100 to 400 W models. When the amount of regeneration is large, connect the necessary regeneration resistor between B1 and B2.
- \*4. To use a DC reactor, remove the short-circuit wire and connect the DC reactor between N1 and N2.

**Note:** The input functions of pins 12 to 15 and 32 to 35, and output functions of pins 9 to 11 and 29 to 31, can be changed via parameter settings.

Single-phase, 230 VAC (1.5 kW model)

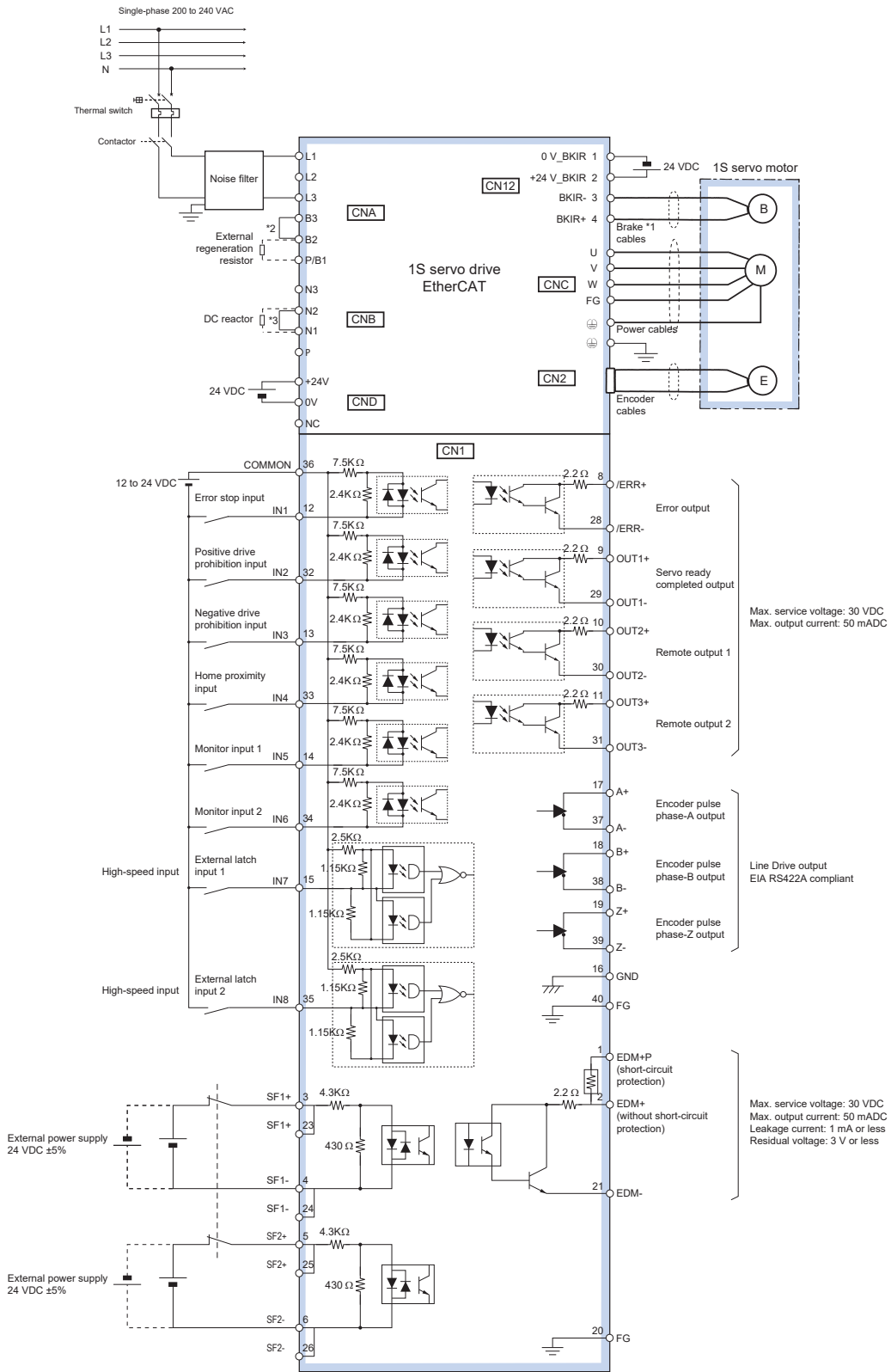

- \*1. There is no polarity on the brake.
- \*2. B2 and B3 are short-circuited. If the internal regenerative resistor is insufficient, remove the wire between B2 and B3 and connect an external regenerative resistor between B1 and B2.
- \*3. To use a DC reactor, remove the short-circuit wire and connect the DC reactor between N1 and N2.

**Note:** The input functions of pins 12 to 15 and 32 to 35, and output functions of pins 9 to 11 and 29 to 31, can be changed via parameter settings.

Three-phase, 400 VAC (600 W to 3 kW models)

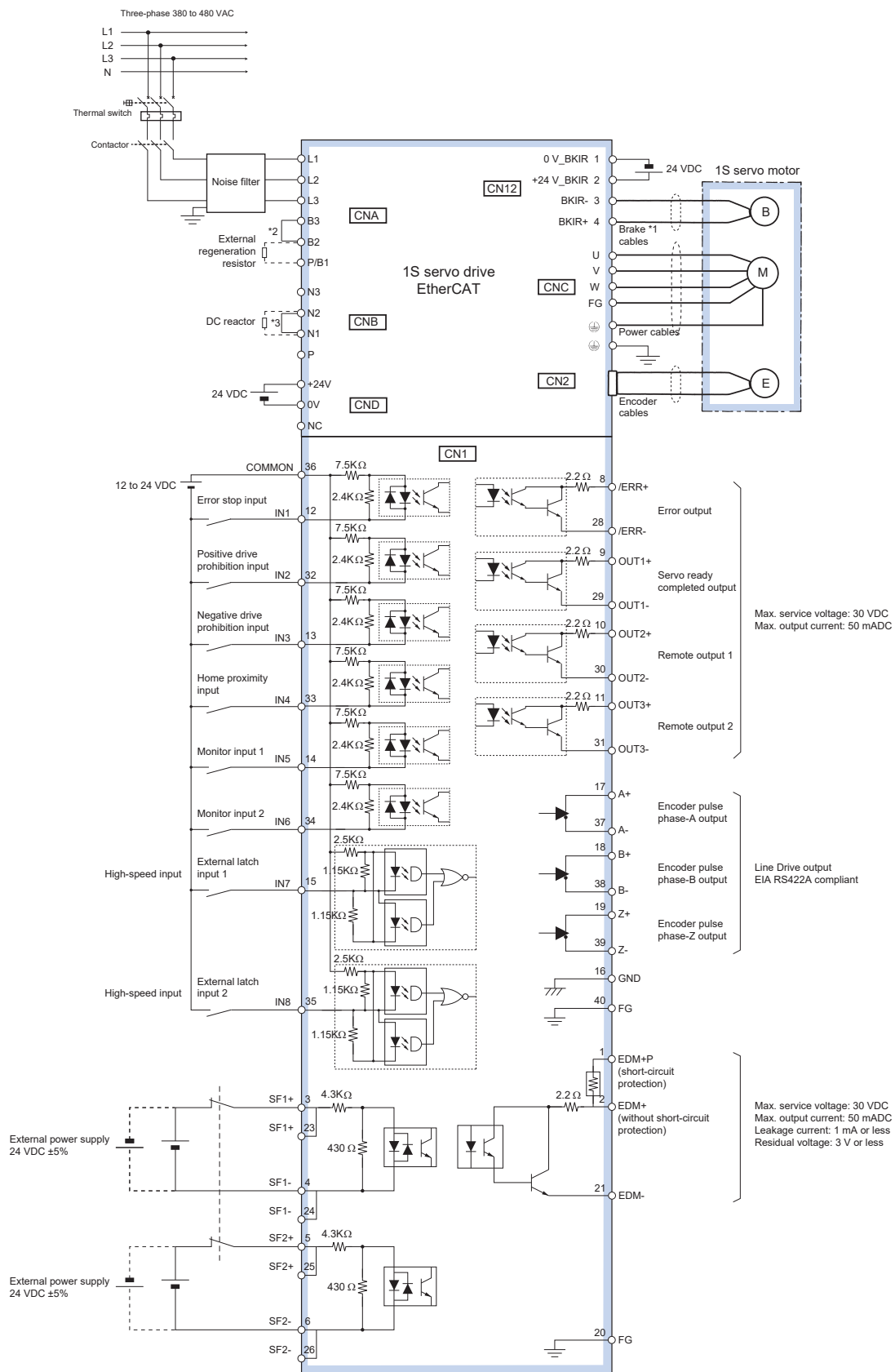

- \*1. There is no polarity on the brake.
- \*2. B2 and B3 are short-circuited. If the internal regenerative resistor is insufficient, remove the wire between B2 and B3 and connect an external regenerative resistor between B1 and B2.
- \*3. To use a DC reactor, remove the short-circuit wire and connect the DC reactor between N1 and N2.

**Note:** The input functions of pins 12 to 15 and 32 to 35, and output functions of pins 9 to 11 and 29 to 31, can be changed via parameter settings.

Three-phase, 400 VAC (5.5 kW to 7.5 kW models)

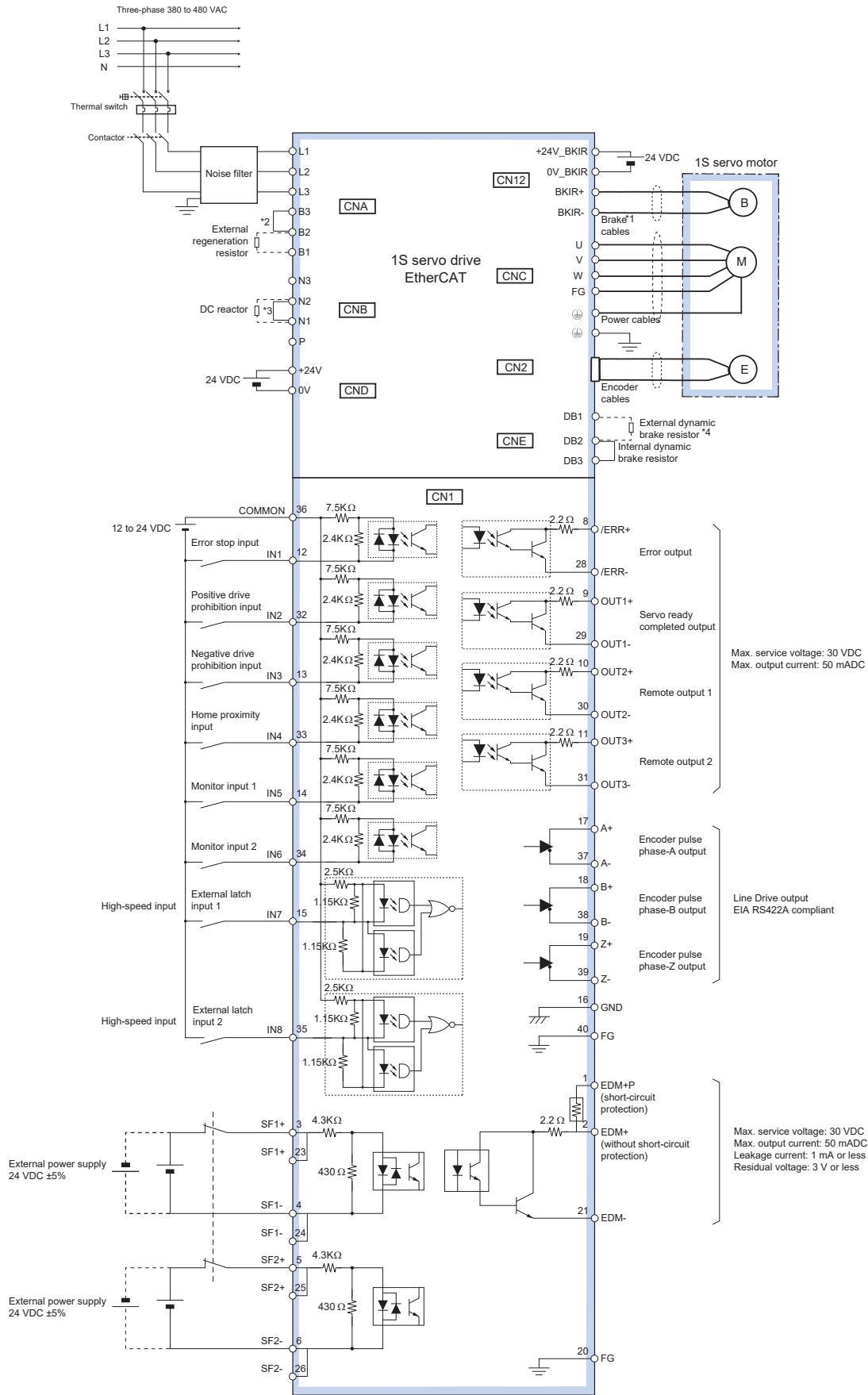

\*1. There is no polarity on the brake.  
 \*2. B2 and B3 are short-circuited. If the internal regenerative resistor is insufficient, remove the wire between B2 and B3 and connect an external regenerative resistor between B1 and B2.  
 \*3. To use a DC reactor, remove the short-circuit wire and connect the DC reactor between N1 and N2.  
 \*4. Short-circuit DB2 and DB3 for models with a built-in dynamic brake resistor. When the amount of braking energy is large, remove the short-circuit wire between DB2 and DB3 and connect a dynamic brake resistor between B1 and B2.

Three-phase, 400 VAC (15 kW model)

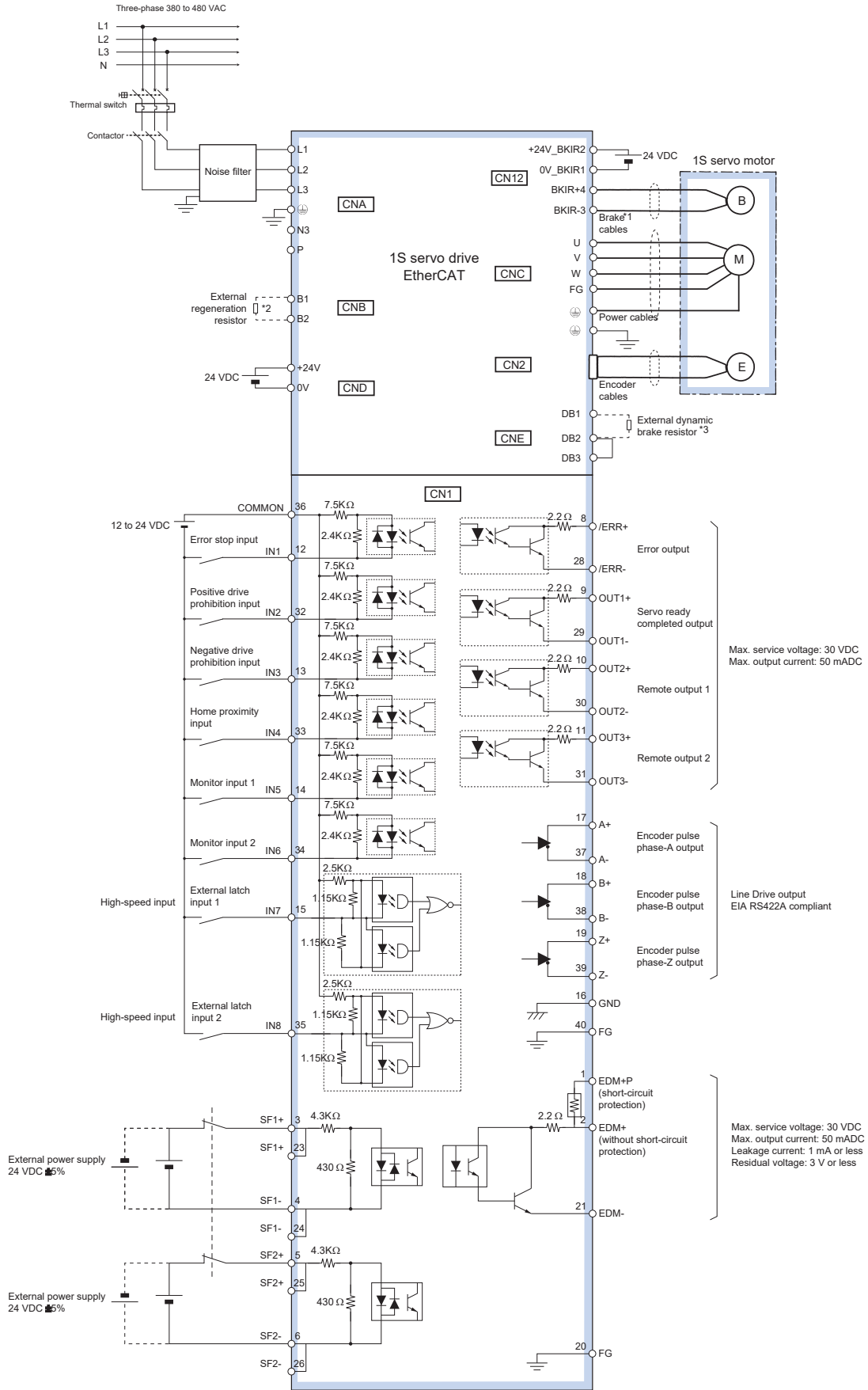

\*1. There is no polarity on the brake.

\*2. \*There is no built-in regeneration resistor. Connect a required regeneration resistor between B1 and B2.

\*3. Short-circuit DB2 and DB3 for models with a built-in dynamic brake resistor. When the amount of braking energy is large, remove the short-circuit wire between DB2 and DB3 and connect a dynamic brake resistor between B1 and B2.

Ordering information

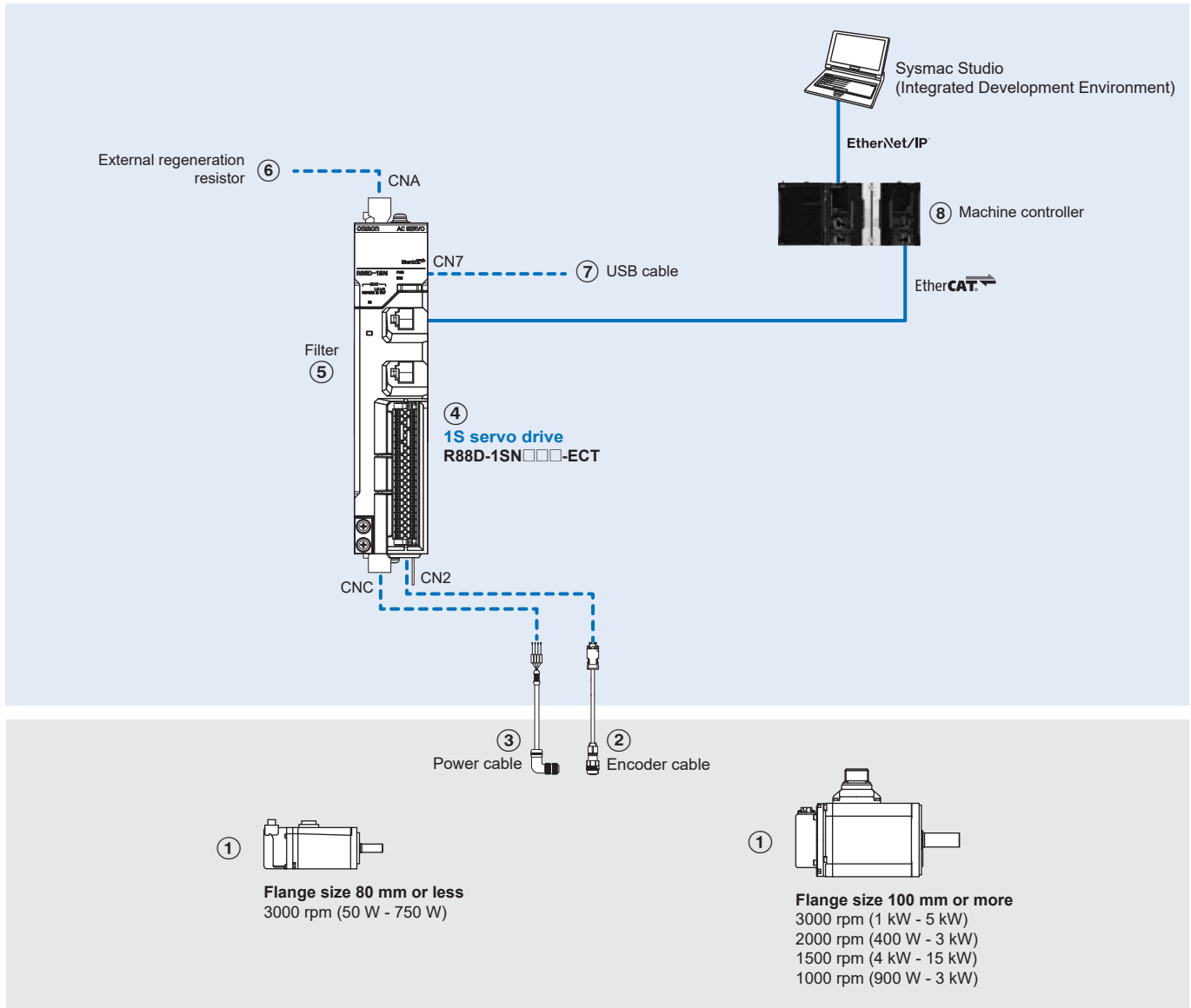

Servo motors, power & encoder cables

①②③ Refer to the 1S servo motor chapter for servo motor, motor cables or connectors selection.

## Servo drives

| Symbol          | Specifications       | Compatible 1S servo motor | Model               |                 |
|-----------------|----------------------|---------------------------|---------------------|-----------------|
| ④               | Single-phase 230 VAC | 50 W                      | R88M-1M05030T-□     | R88D-1SN01H-ECT |
|                 |                      | 100 W                     | R88M-1M10030(H/T)-□ |                 |
|                 |                      | 200 W                     | R88M-1M20030(H/T)-□ | R88D-1SN02H-ECT |
|                 |                      | 400 W                     | R88M-1M40030(H/T)-□ | R88D-1SN04H-ECT |
|                 |                      | 750 W                     | R88M-1M75030(H/T)-□ | R88D-1SN08H-ECT |
|                 |                      | 1.5 kW                    | R88M-1L1K030(H/T)-□ | R88D-1SN15H-ECT |
|                 |                      |                           | R88M-1L1K530(H/T)-□ |                 |
|                 |                      |                           | R88M-1M1K020(H/T)-□ |                 |
|                 |                      |                           | R88M-1M1K520(H/T)-□ |                 |
|                 |                      |                           | R88M-1M90010T-□     |                 |
|                 | Three-phase 400 VAC  | 600 W                     | R88M-1M40020C-□     | R88D-1SN06F-ECT |
|                 |                      |                           | R88M-1M60020C-□     |                 |
|                 |                      | 1 kW                      | R88M-1L75030C-□     | R88D-1SN10F-ECT |
|                 |                      |                           | R88M-1L1K030C-□     |                 |
|                 |                      |                           | R88M-1M1K020C-□     |                 |
|                 |                      |                           | R88M-1M90010C-□     |                 |
|                 |                      | 1.5 kW                    | R88M-1L1K530C-□     | R88D-1SN15F-ECT |
|                 |                      |                           | R88M-1M1K520C-□     |                 |
|                 |                      | 2 kW                      | R88M-1L2K030C-□     | R88D-1SN20F-ECT |
|                 |                      |                           | R88M-1M2K020C-□     |                 |
| R88M-1M2K010C-□ |                      |                           |                     |                 |
| 3 kW            | R88M-1L3K030C-□      | R88D-1SN30F-ECT           |                     |                 |
|                 | R88M-1M3K020C-□      |                           |                     |                 |
|                 | R88M-1M3K010C-□      |                           |                     |                 |
| 5.5 kW          | R88M-1L4K030C-□      | R88D-1SN55F-ECT           |                     |                 |
|                 | R88M-1M4K015C-□      |                           |                     |                 |
|                 | R88M-1L5K030C-□      |                           |                     |                 |
|                 | R88M-1M5K515C-□      |                           |                     |                 |
| 7.5 kW          | R88M-1M7K515C-□      | R88D-1SN75F-ECT           |                     |                 |
| 15 kW           | R88M-1M11K015C-□     | R88D-1SN150F-ECT          |                     |                 |
|                 | R88M-1M15K015C-□     |                           |                     |                 |

## Filters

| Symbol | Applicable 1S servo drive   | Manufacturer           | Rated current | Leakage current | Rated voltage | Model           |
|--------|---|------------------------|---------------|-----------------|---------------|-----------------|
| ⑤      | R88D-1SN01H-ECT, R88D-1SN02H-ECT  | Schaffner EMC Co. Ltd. | 3 A           | 7.83 mA         | 250 VAC       | R88A-FI1S103-SE |
|        | R88D-1SN04H-ECT   |                        | 5 A           |                 |               | R88A-FI1S105-SE |
|        | R88D-1SN08H-ECT   |                        | 8 A           |                 |               | R88A-FI1S108-SE |
|        | R88D-1SN15H-ECT   |                        | 16 A          |                 |               | R88A-FI1S116-SE |
|        | R88D-1SN06F-ECT, R88D-1SN10F-ECT, R88D-1SN15F-ECT, R88D-1SN20F-ECT, R88D-1SN30F-ECT |                        | 9 A           | 1.2 mA          | 400 VAC       | R88A-FI1S309-SE |
|        | R88D-1SN55F-ECT, R88D-1SN75F-ECT  |                        | 30 A          | 0.6 mA          |               | R88A-FI1S330-SE |
|        | R88D-1SN150F-ECT  |                        | 50 A          | 2.4 mA          |               | R88A-FI1S350-SE |

## External regeneration resistor

| Symbol | Resistance value | Regeneration absorption for 120°C temperature rise | Nominal capacity | Model        |
|--------|------------------|--|------------------|--------------|
| ⑥      | 25 Ω             | 24 W   | 120 W            | R88A-RR12025 |
|        | 20 Ω             | 60 W   | 300 W            | R88A-RR30020 |
|        | 25 Ω             |  |                  | R88A-RR30025 |
|        | 33 Ω             |  |                  | R88A-RR30033 |
|        | 16 Ω             |  |                  | R88A-RR30016 |
|        | 10 Ω             |  |                  | R88A-RR30010 |

## ⑦ USB cable

Use a commercially available USB cable that is double-shielded, gold-plated and supports USB 2.0. The Micro B type USB cable can be used.

## Machine controller

| Symbol | Name               | Model                                       |         |
|--------|--------------------|---|---------|
| ⑧      | Industrial PC      | Box PC type                                 | NY512-□ |
|        |                    | Panel PC type (Box PC + Monitor integrated) | NY532-□ |
|        | Modular controller | NX7 series                                  | NX701-□ |
|        |                    | NJ series                                   | NJ□01-□ |
|        |                    | NX1 series                                  | NX102-□ |
|        | Compact controller | NX1P series                                 | NX1P2-□ |

## Servo drive connectors (spare parts)

| Applicable servo drive            | Specifications                         | Model       |
|-----------------------------------|--|-------------|
| R88D-1SN(01H/02H/04H/08H)-ECT     | Main circuit connector (CNA)           | R88A-CN102P |
|                                   | Motor connector (CNC)                  | R88A-CN101A |
| R88D-1SN15H-ECT                   | Main circuit connector A (CNA)         | R88A-CN103P |
| R88D-1SN(06F/10F/15F/20F/30F)-ECT | Main circuit connector B (CNB)         | R88A-CN104P |
|                                   | Motor connector (CNC)                  | R88A-CN102A |
|                                   | Control power supply connector (CND)   | R88A-CN101P |
| R88D-1SN(55F/75F)-ECT             | Main circuit connector A (CNA)         | R88A-CN106P |
|                                   | Main circuit connector B (CNB)         | R88A-CN107P |
|                                   | Motor connector (CNC)                  | R88A-CN103A |
|                                   | Control power supply connector (CND)   | R88A-CN105P |
|                                   | Main circuit connector E (CNE)         | R88A-CN101D |
| R88D-1SN150F-ECT                  | Main circuit connector B (CNB)         | R88A-CN101E |
|                                   | Motor connector (CNC)                  | R88A-CN103A |
|                                   | Control power supply connector (CND)   | R88A-CN105P |
|                                   | Main circuit connector E (CNE)         | R88A-CN101D |
| Common to all models              | Control I/O and safety connector (CN1) | R88A-CN101C |
|                                   | Encoder connector (CN2)                | R88A-CN101R |
|                                   | Brake interlock connector (CN12)       | R88A-CN101B |

## Cable clamp (spare parts)

| Applicable 1S power cable     | Model         |
|-------------------------------|---------------|
| 230 V, 100 W to 750 W models  | R88A-SC011S-E |
| 230 V, 1.5 kW model           | R88A-SC021S-E |
| 400 V, 600 W to 3 kW models   |               |
| 400 V, 5.5 kW to 15 kW models | R88A-SC10CA   |

## Computer software

| Specifications                       | Model         |
|--------------------------------------|---------------|
| Sysmac Studio version 1.16 or higher | SYSMAC-SE2□□□ |

ALL DIMENSIONS SHOWN ARE IN MILLIMETERS.

To convert millimeters into inches, multiply by 0.03937. To convert grams into ounces, multiply by 0.03527.



# SCATTERGOOD & JOHNSON LTD

ELECTRICAL ENGINEERING & FLUID CONTROL DISTRIBUTORS

Est.1899

At Scattergood & Johnson Ltd, we pride ourselves on being a technical distributor to specialist industries.

Working with a range of quality product suppliers across a number of specialist markets, we are not your average 'box shifter' - we are your technical and supply chain partner.

We fully support every product we sell - for free! Our internal team and external sales engineers can answer any product or application question, no matter the complexity.

Backing up this technical ability is a range of 50,000+ products available from stock for nationwide next day delivery (same day if required!), or you can collect what you need from any of our trade counters around the UK.

Select your specialist interest below to learn more about how we can help.



Online, In Branch and On the Road - Scattergood & Johnson Ltd, there when you need us.

# [www.scatts.co.uk](http://www.scatts.co.uk)