

Safety Relay Unit

G9SA

The G9SA Series Offers a Complete Line-up of Compact Units.

- Four kinds of 45-mm wide Units are available:
A 3-safety contact model, a 5-safety contact model, and models with 3 safety contacts and 2 OFF-delay safety contacts.
Also available are 17.5-mm wide Expansion Units with 3 safety contacts and 3 OFF-delay safety contacts.
- Two hand controller (type III C, EN 574)
- Simple expansion connection.
- OFF-delay models have 15-step OFF-delay settings.
- Conforms to EN standards. (BG approval)
- Approved by UL and CSA.
- Both DIN track mounting and screw mounting are possible.
- Suitable for PNP OSSD outputs of safety sensors, F3SN, F3SH, F3S-B, F3S-TGR, F3SL



Ordering Information

Emergency-stop Units

Main contacts	Auxiliary contact	Number of input channels	Rated voltage	Model	Category
3PST-NO	SPST-NC	1 channel or 2 channels possible	24 VAC/VDC 100 to 240 VAC	G9SA-301	4
5PST-NO	SPST-NC	1 channel or 2 channels possible	24 VAC/VDC 100 to 240 VAC	G9SA-501	

Emergency-stop OFF-delay Units

Main contacts	OFF-delay contacts	Auxiliary contact	Number of input channels	OFF-delay time	Rated voltage	Model	Category
3PST-NO	DPST-NO	SPST-NC	1 channel or 2 channels possible	7.5 s	24 VAC/VDC	G9SA-321-T075	Main contacts: 4 OFF-delay contacts: 3
					100 to 240 VAC		
				15 s	24 VAC/VDC	G9SA-321-T15	
					100 to 240 VAC		
				30 s	24 VAC/VDC	G9SA-321-T30	
					100 to 240 VAC		

Note: The following 15-step OFF-delay time settings are available:
 T075: 0.5, 1, 1.5, 2, 2.5, 3, 3.5, 4, 4.5, 5, 5.5, 6, 6.5, 7, and 7.5 s
 T15: 1, 2, 3, 4, 5, 6, 7, 8, 9, 10, 11, 12, 13, 14, and 15 s
 T30: 2, 4, 6, 8, 10, 12, 14, 16, 18, 20, 22, 24, 26, 28, and 30 s

Two-hand Controller

Main contacts	Auxiliary contact	Number of input channels	Rated voltage	Model	Category
3PST-NO	SPST-NC	2 channels	24 VAC/VDC 100 to 240 VAC	G9SA-TH301	4 (IIIc, EN574)

Expansion Unit

321, or G9SA-TH301.

The Expansion Unit connects to a G9SA-301, G9SA-501, G9SA-

Main contacts	Auxiliary contact	Model	Category
3PST-NO	SPST-NC	G9SA-EX301	4

Specifications

Ratings

Power Input

Item	G9SA-301/TH301	G9SA-501	G9SA-321-T□
Power supply voltage	24 VAC/VDC: 24 VAC, 50/60 Hz, or 24 VDC 100 to 240 VAC: 100 to 240 VAC, 50/60 Hz		
Operating voltage range	85% to 110% of rated power supply voltage		
Power consumption (See note.)	24 VAC/VDC: 1.8 VA/1.7 W max. 100 to 240 VAC: 9 VA max.	24 VAC/VDC: 2.8 VA/2.6 W max. 100 to 240 VAC: 11 VA max.	24 VAC/VDC: 3.5 VA/3.3 W max. 100 to 240 VAC: 12.5 VA max.

Note: When an Expansion Unit is connected, the power consumption is increased by 2 VA/2 W max.

Inputs

Item	G9SA-301/321-T□/TH301	G9SA-501
Input current (See note.)	40 mA max.	60 mA max.

Note: When an Expansion Unit is connected, the input current is increased by 30 mA max.

Contacts

Item	G9SA-301/501/321-T□/TH301/EX301/EX031-T□
	Resistive load ($\cos \phi = 1$)
Rated load	250 VAC, 5 A
Rated carry current	5 A

Characteristics

Item	G9SA-301/TH301	G9SA-501/321-T□	G9SA-EX301/EX031-T□
Contact resistance (see note 1)	100 mΩ		
Operating time	30 ms max. (not including bounce time)		
Response time (see note 2)	10 ms max. (not including bounce time)		
Insulation resistance (see note 3)	100 MΩ min. (at 500 VDC)		
Dielectric strength	Between different outputs	2,500 VAC, 50/60 Hz for 1 min	
	Between inputs and outputs		
	Between power inputs and outputs		
	Between power inputs and other inputs (only for 100 to 240-V models)		
Vibration resistance	10 to 55 Hz, 0.75-mm double amplitude		
Shock resistance	Destruction	300 m/s ²	
	Malfuction	100 m/s ²	
Durability	Mechanical	5,000,000 operations min. (at approx. 7,200 operations/hr)	
	Electrical	100,000 operations min. (at approx. 1,800 operations/hr)	
Minimum permissible load (reference value)	5 VDC, 1 mA		
Ambient temperature	Operating: -25°C to 55°C (with no icing or condensation) Storage: -25°C to 85°C (with no icing or condensation)		
Ambient humidity	Operating: 35% to 85% Storage: 35% to 85%		
Terminal tightening torque	0.98 N·m		
Weight (see note 4)	Approx. 210 g	Approx. 270 g	Approx. 130 g
Approved standards	EN954-1, EN60204-1, EN574 (-TH301), UL508, CSA C22.2 No. 14		
EMC	EMI: EN55011 group 1 class A EMS: EN50082-2 group 1		

Note: 1. The contact resistance was measured with 1 A at 5 VDC using the voltage-drop method.

2. The response time is the time it takes for the main contact to open after the input is turned OFF.

3. The insulation resistance was measured with 500 VDC at the same places that the dielectric strength was checked.

4. Weight shown is for 24-VAC/VDC type. For 100 to 240-VAC type, add approximately 20 g.

Application Examples

G9SA-301 (24 VAC/VDC) with 2-channel Limit Switch Input/Auto-reset

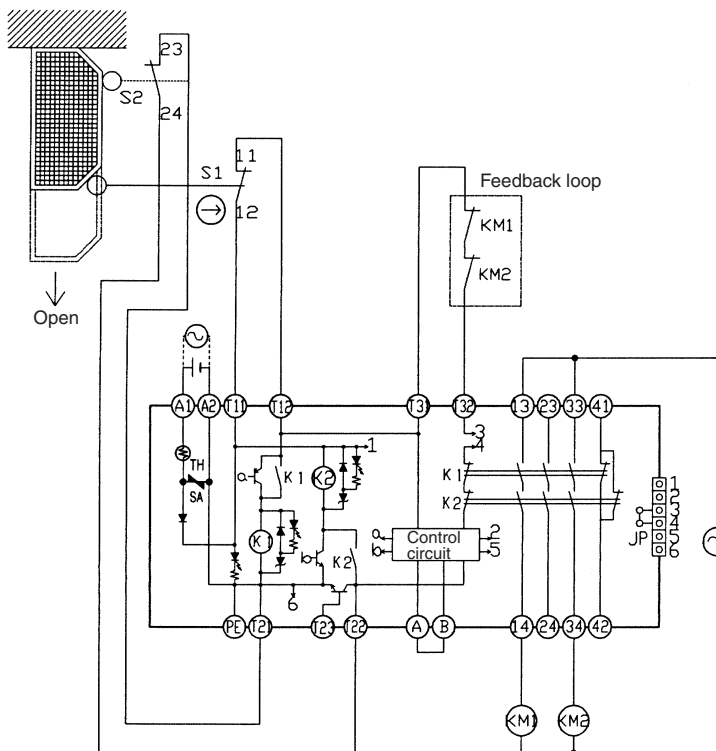

Timing Chart

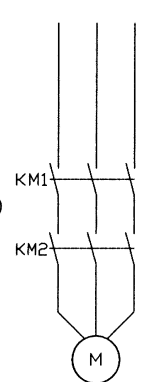
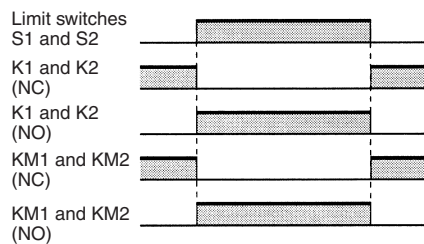

- S1: Safety Limit Switch with direct opening mechanism (D4N or D4B) ⊕
 - S2: Limit switch
 - KM1 and KM2: Magnetic Contactor
 - M: 3-phase motor
- Note:** This circuit achieves EN954-1 Safety Category 4.

G9SA-301 (24 VAC/VDC) with 2-channel Limit Switch Input/Manual-reset

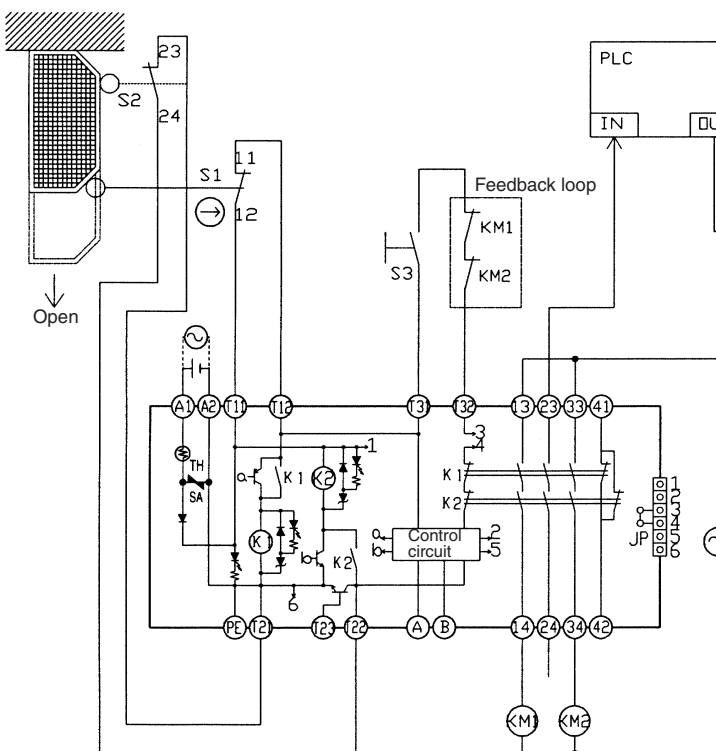

Timing Chart

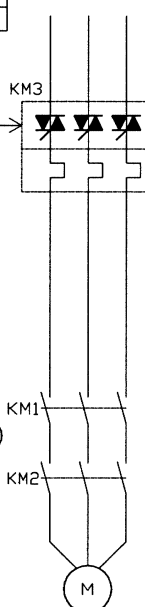
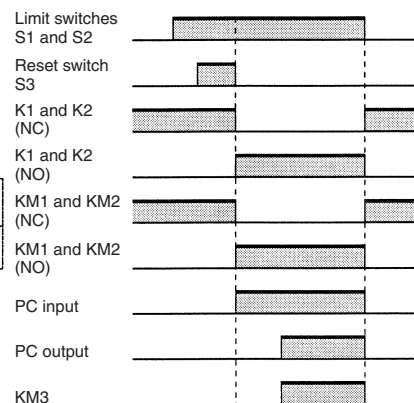

- S1: Safety Limit Switch with direct opening mechanism (D4N or D4B) ⊕
 - S2: Limit switch
 - S3: Reset switch
 - KM1 and KM2: Magnetic Contactor
 - KM3: Solid-state Contactor
 - M: 3-phase motor
- Note:** This circuit achieves EN954-1 Safety Category 4.

G9SA-301 (100 to 240 VAC) with 2-channel Limit Switch Input/Auto-reset

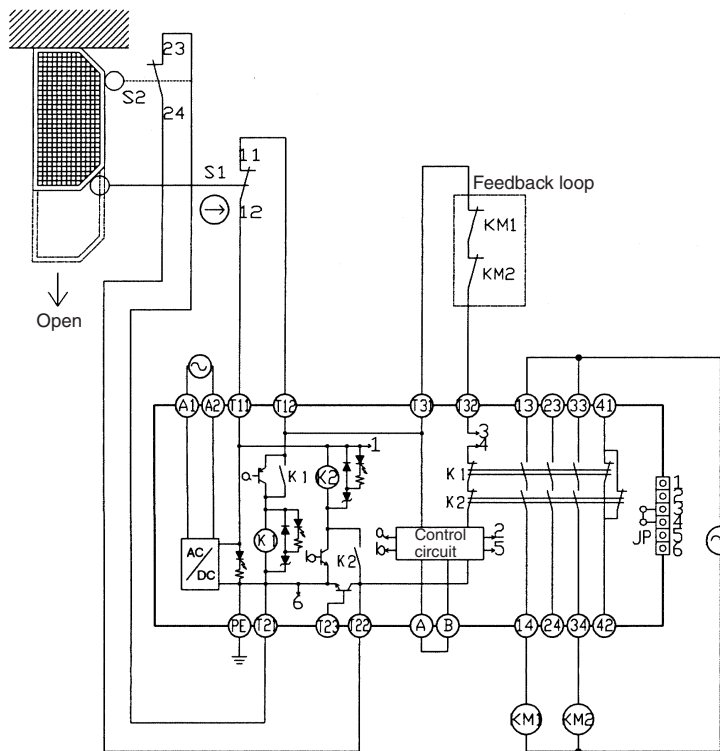

Timing Chart

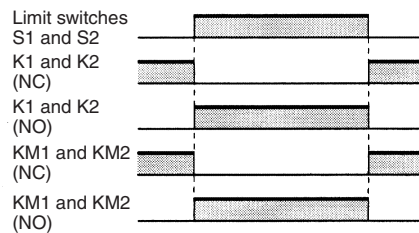

- S1: Safety Limit Switch with direct opening mechanism (D4N or D4B) ⊕
- S2: Limit switch
- KM1 and KM2: Magnetic Contactor
- M: 3-phase motor

Note: This circuit achieves EN954-1 Safety Category 4.

G9SA-301 (24 VAC/VDC) with 2-channel Emergency Stop Switch Input/Manual-reset

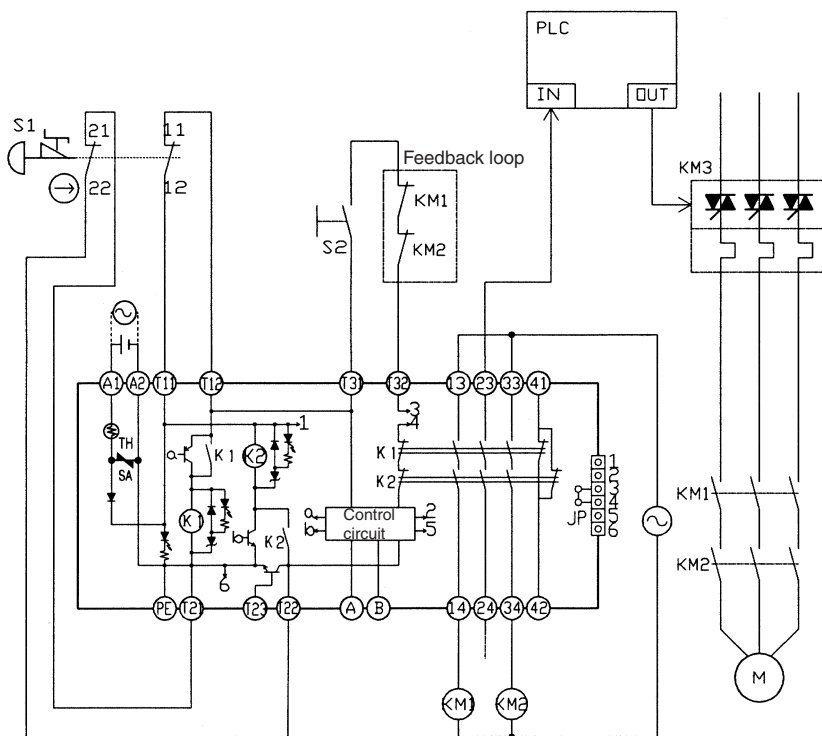

Timing Chart

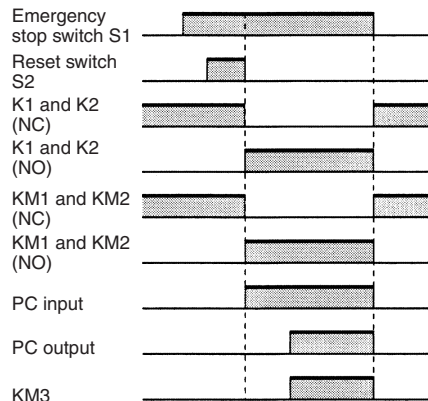

- S1: Emergency stop switch with direct opening mechanism (A165E or A22E) ⊕
- S2: Reset switch
- KM1 and KM2: Magnetic Contactor
- KM3: Solid-state Contactor
- M: 3-phase motor

Note: This circuit achieves EN954-1 Safety Category 4.

G9SA-321-T□ (24 VAC/VDC) with 2-channel Limit Switch Input/Manual-reset

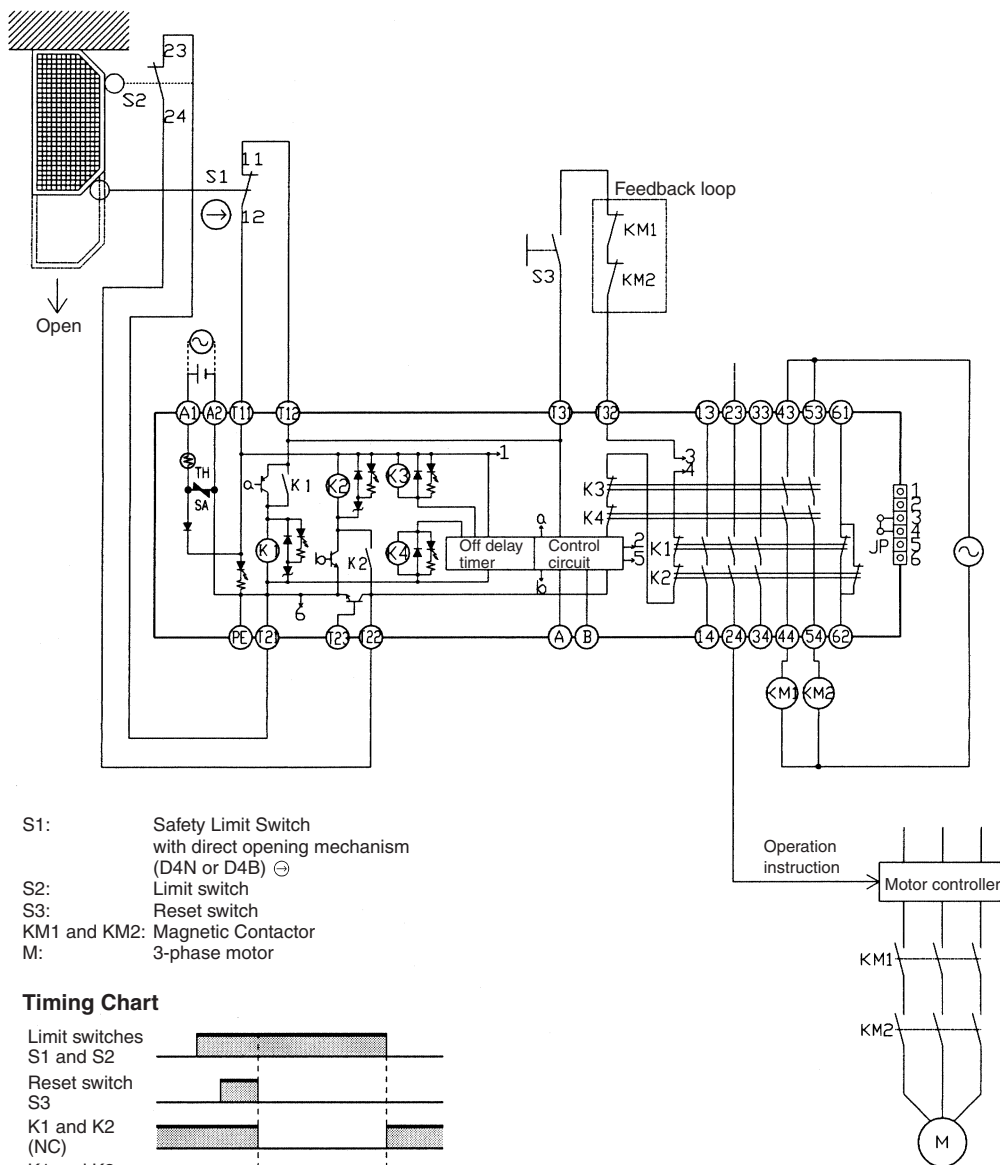

- S1: Safety Limit Switch with direct opening mechanism (D4N or D4B) ⊖
- S2: Limit switch
- S3: Reset switch
- KM1 and KM2: Magnetic Contactor
- M: 3-phase motor

Timing Chart

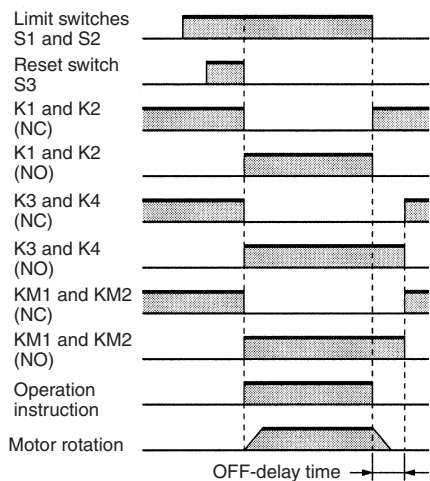

Note: This circuit achieves EN954-1 Safety Category 4. The OFF-delay output, however, achieves EN954-1 Safety Category 3.

G9SA-321-T□ (24 VAC/VDC) + G9SA-EX031-T□ with 2-channel Limit Switch Input/Manual-reset

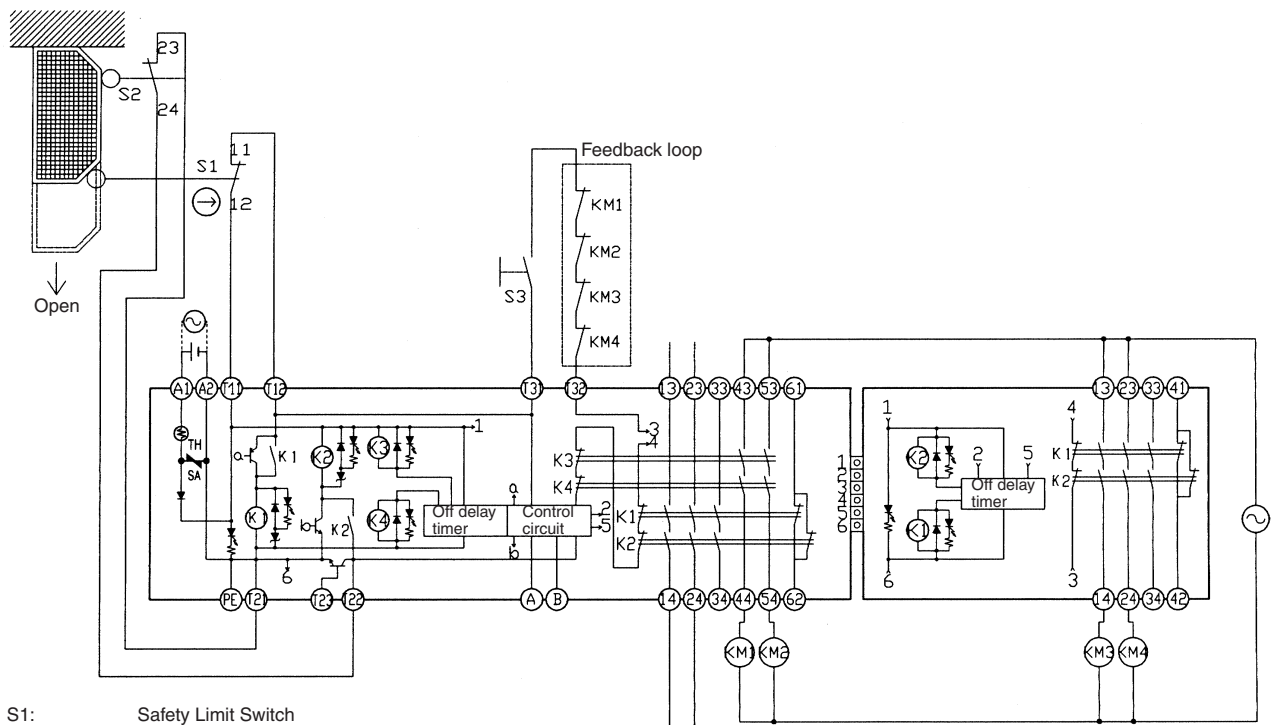

- S1: Safety Limit Switch with direct opening mechanism (D4N or D4B) ⊖
- S2: Limit switch
- S3: Reset switch
- KM1, KM2, KM3, and KM4: Magnetic Contactor
- M1, M2: 3-phase motor

Timing Chart

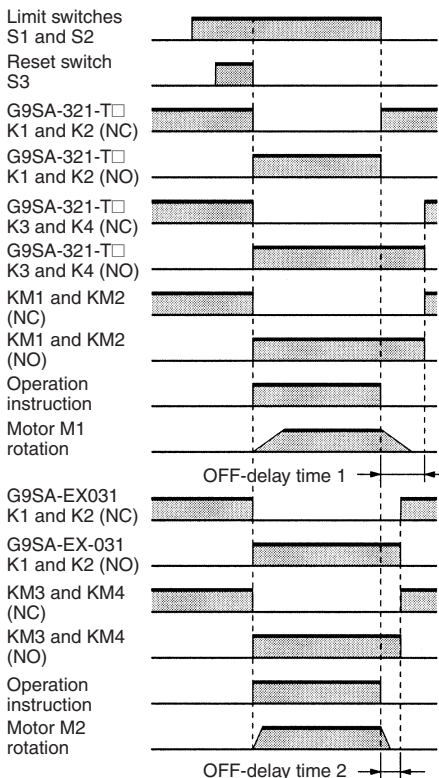

Note: This circuit achieves EN954-1 Safety Category 4. The OFF-delay output, however, achieves EN954-1 Safety Category 3.

G9SA-301 (24 VAC/VDC) with 2-channel Safety Area Sensor/Manual-reset

Timing Chart

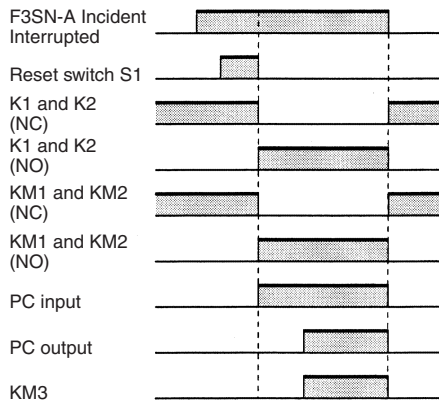

- F3SN-A: Safety area sensor
- S1: Reset switch
- KM1 and KM2: Magnetic Contactor
- KM3: Solid-state Contactor
- M: 3-phase motor
- E1: 24-VDC Power Supply

Note: This circuit achieves EN954-1 Safety Category 4.

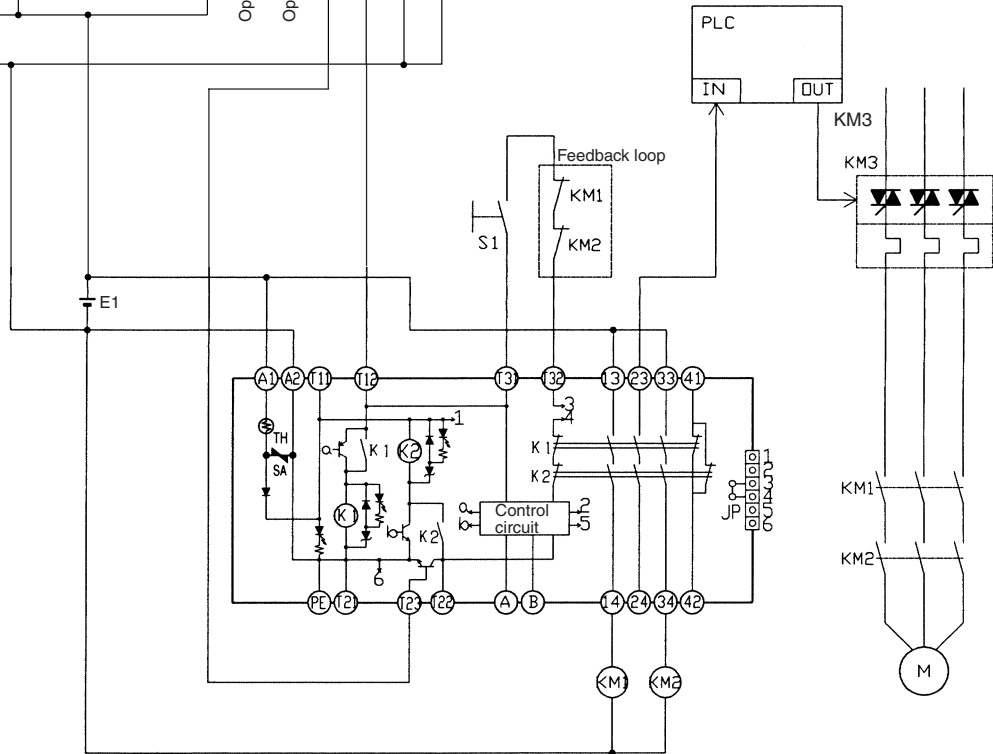
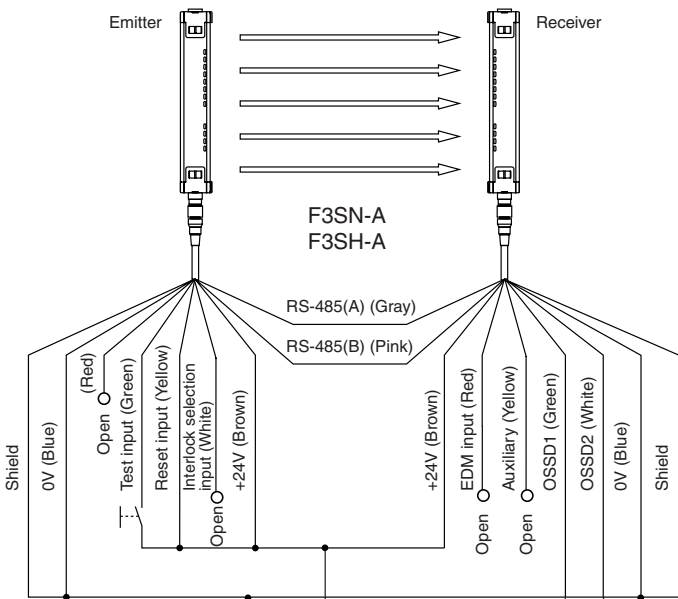

G9SA-TH301 (24 VDC) with 2-hand Inputs/Auto-reset

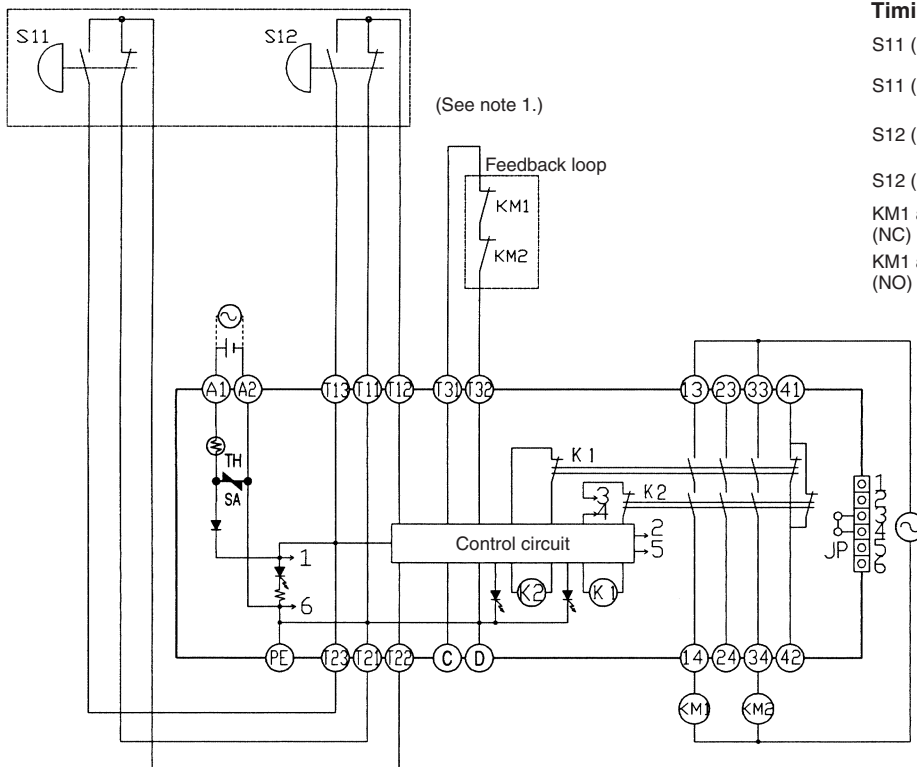

Timing Chart

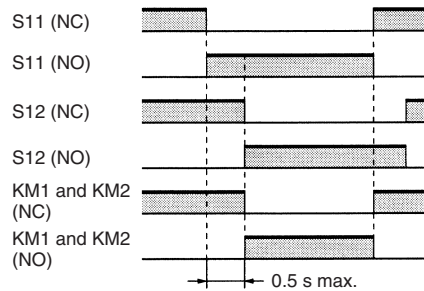

Input time difference operates only when the difference is 0.5 s max.

S11, S12: Two-hand pushbutton switches
 KM1 and KM2: Magnetic Contactor

- Note: 1. Use a 1NC+1NO switch for S11 and S12.
- 2. This circuit achieves EN954-1 Safety Category 4. Typ III C (EN 574)

G9SA-501 (24 VAC/VDC) and G9SA-EX301 with 2-channel Limit Switch Input/Manual-reset

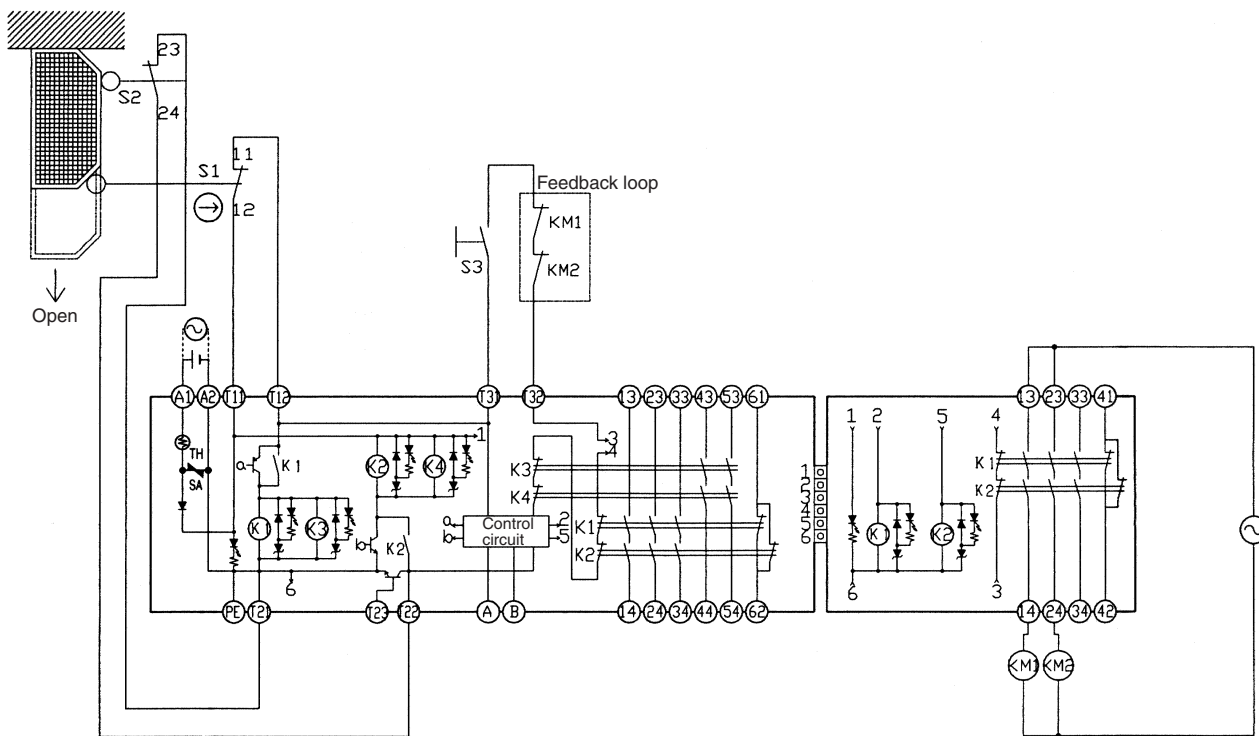

- S1: Safety Limit Switch with direct opening mechanism (D4N or D4B) ⊖
- S2: Limit switch
- S3: Reset switch
- KM1 and KM2: Magnetic Contactor
- M: 3-phase motor

Timing Chart

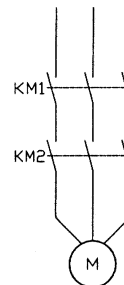
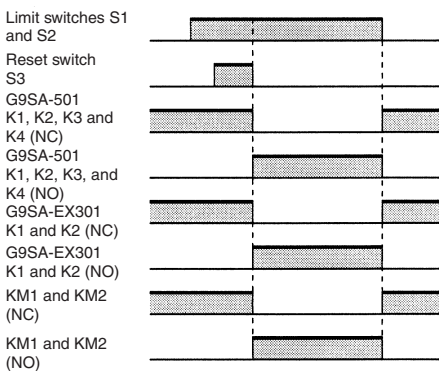

Note: This circuit achieves EN954-1 Safety Category 4.

Dimensions

Note: All units are in millimeters unless otherwise indicated. The diagrams are drawn in perspective.

G9SA-301
G9SA-501
G9SA-321-T□
G9SA-TH301

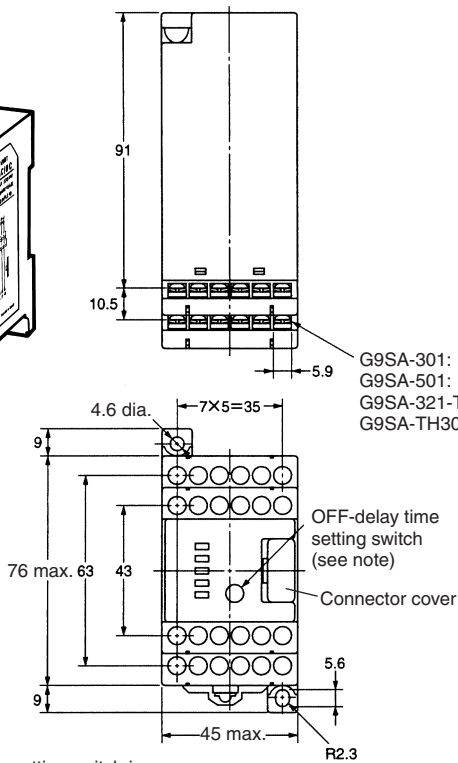
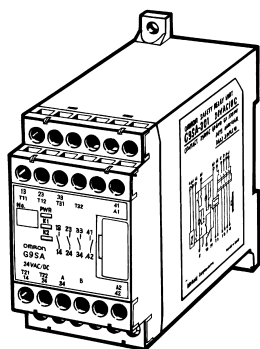

G9SA-301: Twenty, M3
G9SA-501: Twenty-four, M3
G9SA-321-T□: Twenty-four, M3
G9SA-TH301: Twenty-one, M3

Terminal Arrangement

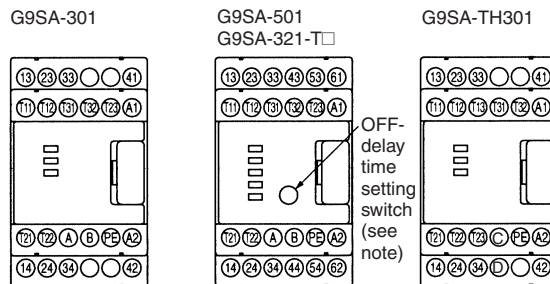

OFF-delay time setting switch (see note)

Mounting Holes

Two, 4.2 dia. or M4

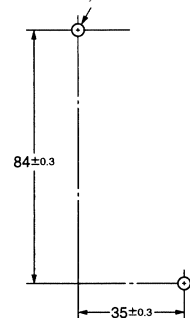

Note: The OFF-delay time setting switch is found on the G9SA-321-T□ only.

G9SA-EX301
G9SA-EX031-T□

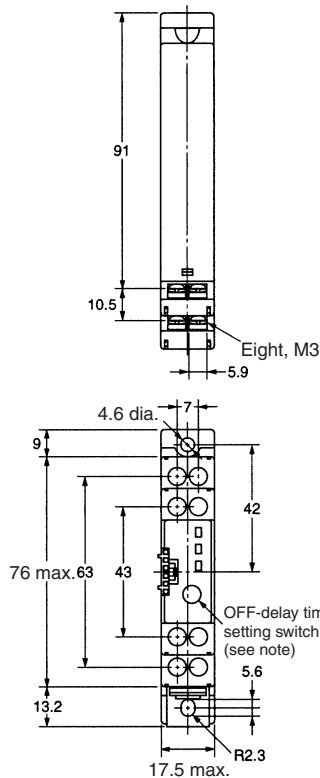
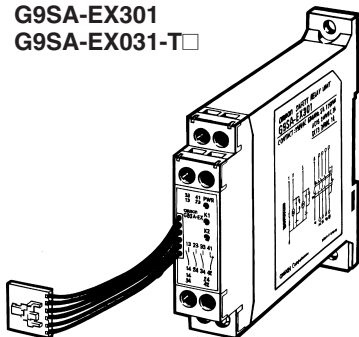

Eight, M3

Mounting Holes

Two, 4.2 dia. or M4

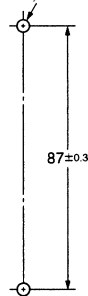

Terminal Arrangement

G9SA-EX301
G9SA-EX031-T□

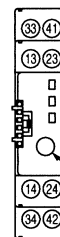

OFF-delay time setting switch (see note)

Note: The OFF-delay time setting switch is found on the G9SA-EX031-T□ only.

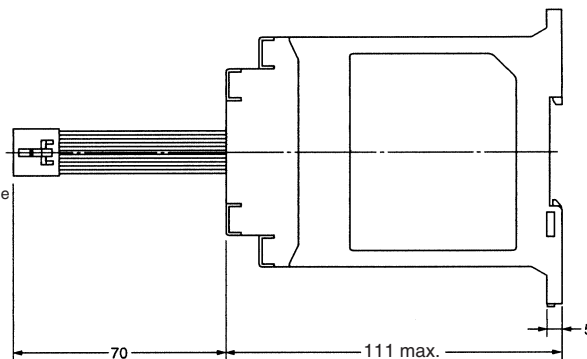

Precautions

Do not touch the terminal area of the Relays or the socket terminal area (charged area) while power is ON. Electric shock will result.

Wiring

Turn OFF the G9SA before wiring the G9SA. Do not touch the terminals of the G9SA while the power is turned ON, because the terminals are charged and may cause an electric shock.

Use the following to wire the G9SA.

Stranded wire: 0.75 to 1.5 mm²

Solid wire: 1.0 to 1.5 mm²

Tighten each screw to a torque of 0.78 to 1.18 N·m, or the G9SA may malfunction or generate heat.

External inputs connected to T11 and T12 or T21 and T22 of the G9SA-301 must be no-voltage contact inputs.

PE is a ground terminal.

When a machine is grounded at the positive, the PE terminal should not be grounded.

Mounting Expansion Units

Turn OFF the G9SA before connecting the Expansion Unit.

When an Expansion Unit is being used, remove the connector cover from the G9SA Safety Relay Unit (G9SA-301, G9SA-501, G9SA-321□, or G9SA-TH301) and insert the connector of the Expansion Unit's connector cable.

Applicable Safety Category (EN954-1)

G9SA-series Relays meet the requirements of Safety Category 4 of the EN954-1 standards when they are used as shown in the examples provided by OMRON. The Relays may not meet the standards in some operating conditions. The OFF-delay output of models G9SA-321-T□ and EX031-T□, however, conform to Safety Category 3.

The applicable safety category is determined from the whole safety control system. Make sure that the whole safety control system meets EN954-1 requirements.

Mounting Multiple Units

When mounting multiple Units close to each other, the rated current will be 3 A. Do not apply a current higher than 3 A.

Connecting Inputs

If using multiple G9SA models, inputs cannot be made using the same switch. This is also true for other input terminals.

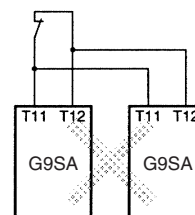

Earth Short

A positive thermistor is built into the G9SA circuits, so you can detect earth short breakdowns and breakdown shorts between channel 1 and channel 2. If the short breakdown is canceled, reset is automatic.

ALL DIMENSIONS SHOWN ARE IN MILLIMETERS.

To convert millimeters into inches, multiply by 0.03937. To convert grams into ounces, multiply by 0.03527.

Cat. No. J121-E2-03A-X

In the interest of product improvement, specifications are subject to change without notice.



SCATTERGOOD & JOHNSON LTD

ELECTRICAL ENGINEERING & FLUID CONTROL DISTRIBUTORS

Est.1899

At Scattergood & Johnson Ltd, we pride ourselves on being a technical distributor to specialist industries.

Working with a range of quality product suppliers across a number of specialist markets, we are not your average 'box shifter' - we are your technical and supply chain partner.

We fully support every product we sell - for free! Our internal team and external sales engineers can answer any product or application question, no matter the complexity.

Backing up this technical ability is a range of 50,000+ products available from stock for nationwide next day delivery (same day if required!), or you can collect what you need from any of our trade counters around the UK.

Select your specialist interest below to learn more about how we can help.



Online, In Branch and On the Road - Scattergood & Johnson Ltd, there when you need us.

www.scatts.co.uk