

1/32 DIN Digital Panel Meter K3GN

Compact and Intelligent Digital Panel Meter

- A single Panel Meter covering a wide range of applications.
 - 3 main applicable functions:
 - Process meter (DC voltage/current input).
 - RPM processor/tachometer (frequency input).
 - Digital data display for PC/PLC (RS-485 communications).
- Easy configuration
 - Multi-range analog input: applicable for all standard analog signals.
 - 6 input ranges available: 4 to 20 mA/0 to 20 mA, 1 to 5 VDC/0 to 5 VDC, ± 5 VDC, ± 10 VDC.
 - 5 KHz max. input-pulse frequency range.
 - Scaling in a wide range of engineering units.
 - Programmable output operation action, decimal point position setting, teaching function for input range, leading zero suppression, average processing.
- Advanced and compact design
 - Very compact 1/32 DIN housing: 48 (W) x 24 (H) x 83 (D).
 - 5-digit display with programmable display color in red or green.
 - Good visibility: High contrast backlit LCD display.
 - High protection against water and dust: NEMA4X/IP66 front panel.
- Selectable outputs: 2 relay outputs, 3 transistor outputs, RS-485, and combinations of these.
- High accuracy: $\pm 0.1\%$ full scale.
- Easy to configure through the front panel or via RS-485.
- EN/IEC conformity with CE marking and UL/CSA approval.



Model Number Structure

Model Number Legend

K3GN - - 24 VDC
 1 2 3

1. Input Type

ND: DC voltage/current, NPN

PD: DC voltage/current, PNP

2. Output Type

C: 2 relay contact outputs (SPST-NO)

T1: 3 transistor outputs (NPN open collector)

T2: 3 transistor outputs (PNP open collector)

3. Communications Output Type

None: Communications not supported

FLK: RS-485

Ordering Information

■ List of Models

Input type	Supply voltage	Output	Communications	
			No communications	RS-485
DC voltage/current, NPN	24 VDC	Dual relays (SPST-NO)	K3GN-NDC 24 VDC	K3GN-NDC-FLK 24 VDC
		Three NPN open collector	K3GN-NDT1 24 VDC	K3GN-NDT1-FLK 24 VDC
DC voltage/current, PNP		Dual relays (SPST-NO)	K3GN-PDC 24 VDC	K3GN-PDC-FLK 24 VDC
		Three PNP open collector	K3GN-PDT2 24 VDC	K3GN-PDT2-FLK 24 VDC

Specifications

■ Ratings

Supply voltage	24 VDC
Operating voltage range	85% to 110% of the rated supply voltage
Power consumption (see note)	2.5 W max. (at max. DC load with all indicators lit)
Insulation resistance	20 MΩ min. (at 500 VDC) between external terminal and case. Insulation provided between inputs, outputs, and power supply.
Dielectric strength	1,000 VAC for 1 min between external terminal and case. Insulation provided between inputs, outputs, and power supply.
Noise immunity	±480 V on power supply terminals in normal mode, ±1,500 V in common mode, ±1 μs, or 100 ns for square-wave noise with 1 ns
Vibration resistance	Malfunction: 10 to 55 Hz, 10 min each in X, Y, and Z directions; acceleration: 9.8 m/s ² Destruction: 10 to 55 Hz, 30 min each in X, Y, and Z directions; acceleration: 19.6 m/s ²
Shock resistance	Malfunction: Models with transistor outputs: 196 m/s ² for 3 times each in X, Y, and Z directions Models with relay contact outputs: 98 m/s ² for 3 times each in X, Y, and Z directions Destruction: 294 m/s ² for 3 times each in X, Y, and Z directions
Ambient temperature	Operating: -10°C to 55°C (with no condensation or icing) Storage: -25°C to 65°C (with no condensation or icing)
Ambient humidity	Operating: 25% to 85% (with no condensation)
EMC	(EMI) EN61326+A1 Industry Emission Enclosure: CISPR 11 Group 1 class A: CISRP16-1/-2 Emission AC Mains: CISPR 11 Group 1 class A: CISRP16-1/-2 (EMS) EN61326+A1 Industry Immunity ESD: EN61000-4-2: 4 kV contact discharge (level 2) 8 kV air discharge (level 3) Immunity RF-interference: EN61000-4-3: 10 V/m (amplitude-modulated, 80 MHz to 1 GHz) (level 3) Immunity Fast Transient Noise: EN61000-4-4: 2 kV (power line) (level 3) Immunity Burst Noise: 1 kV line to line (I/O signal line) Immunity Surge: EN61000-4-5: 1 kV line to line 2 kV line to ground (power line) Immunity Conducted Disturbance EN61000-4-6: 3 V (0.15 to 80 MHz) (level 2) Immunity Voltage Dip/Interrupting EN61000-4-11: 0.5 cycles, 0, 180°, 100% (rated voltage)
Approved standards	UL508, CSA22.2; Conforms to EN61326+A1, EN61010-1 (IEC61010-1) Conforms to VDE0106/P100 (finger protection) when the terminal cover is mounted.
Weight	Approx. 100 g

Note: A control power supply capacity greater than the rated capacity is required when the Digital Panel Meter is turned ON. Do not forget to take this into consideration when using several Digital Panel Meters. When power is supplied, all indicators will light and outputs will be OFF. When using startup compensation time operation, the display will read "00000" and all outputs will be OFF.

■ Characteristics

Input signal	Process voltage (1 to 5 V, 0 to 5 V, $\pm 5V$, $\pm 10 V$) Process current (4 to 20 mA, 0 to 20 mA)	No-voltage contact (30 Hz max. with ON/OFF pulse width of 16 ms min.) Open collector (5 kHz max. with ON/OFF pulse width of 90 μ s min.)	Digital data display (by RS-485 communication)
A/D conversion	Double integral method 14 bit resolution	---	
Sampling period	250 ms	---	
Display refresh period	Sampling period (sampling times multiplied by number of averaging times if average processing is selected.)		
Pulse measurement method	---	Periodic measurement	---
Connectable Sensors	---	ON residual voltage: 2.5 V max. OFF leakage current: 0.1 mA max. Load current: Must have a switching capacity of 15 mA min. Must be able to reliably switch load currents of 5 mA max.	
Max. displayed digits	5 digits (-19999 to 99999)		
Display	7-segment digital display, character height: 7.0 mm		
Polarity display	"..." is displayed automatically with a negative input signal.		
Zero display	Leading zeros are not displayed.		
Scaling function	Programmable with front-panel key inputs (range of display: -19999 to 99999). The decimal point position can be set as desired.		
External controls (see note 1)	HOLD: (Measurement value held) ZERO: (Forced-zero)	---	
Hysteresis setting	Programmable with front-panel key inputs (0001 to 9999).		
Other functions	Programmable Color Display Selectable output operating action Teaching set values Average processing (simple average) Lockout configuration Communications writing control (communications output models only)		
	Forced-zero set with front panel keys Control inputs (HOLD/ZERO) selection via front panel keys Field calibration	Startup compensation time (0.00 to 99.9 s) Auto-zero time (0.0 to 19.9 s)	
Output	Relays: 2 SPST-NO Transistors: 3 NPN open collector 3 PNP open collector Combinations: Communications output (RS-485) + relay outputs (2 SPST-NO); Communications output (RS-485) + transistor outputs (3 NPN open collector); Communications output (RS-485) + transistor outputs (3 PNP open collector)		
Communications	Communications function: RS-485		
Delay in comparative outputs (transistor outputs)	750 ms max.		
Degree of protection	Front panel: NEMA4X for indoor use (equivalent to IP66) Rear case: IEC standard IP20 Terminals: IEC standard IP20		
Memory protection	Non-volatile memory (EEPROM) (possible to rewrite 100,000 times)		

Note 1. The minimum input time for control signals is 80 ms.

2. Refer to *N102 Operation Manual* for more details.

■ Measuring Ranges

Process Voltage/Current Inputs

Input	Measuring range	Measuring accuracy	Input impedance	Displayable range
DC voltage	1.000 to 5.000 V/ 0.000 to 5.000 V	$\pm 0.1\%$ FS ± 1 digit max. (at $23\pm 3^\circ\text{C}$)	1 M Ω min.	-19999 to 99999 (with scaling function)
	-5.000 to 5.000 V	$\pm 0.1\%$ FS ± 1 digit max. (at $23\pm 5^\circ\text{C}$)		
	-10.00 to 10.00 V			
DC current	4.00 to 20.00 mA/ 0.00 to 20.00 mA	$\pm 0.1\%$ FS ± 1 digit max. (at $23\pm 3^\circ\text{C}$)	60 Ω	

No-voltage Contact/Open Collector Inputs

Input	Measuring range	Measuring accuracy (at $23\pm 5^\circ\text{C}$)	Displayable range
No-voltage contact (30 Hz max.) with ON/ OFF pulse width of 16 ms min.	0.05 to 30.00 HZ	$\pm 0.1\%$ FS ± 1 digit max.	-19999 to 99999 (with scaling function)
Open collector (5 kHz max.) with ON/OFF pulse width of 90 μs min.	0 to 5000 HZ		

Digital Data Display (By RS-485 Communications)

Displayable range	-19999 to 99999
-------------------	-----------------

■ Input/Output Ratings

Relay Contact Output

(Incorporating G6K Relays)

Item	Resistive load ($\cos\phi = 1$)
Rated load	1 A at 30 VDC
Rated carry current	1 A max. (at COM terminal)
Max. contact voltage	60 VDC
Max. contact current	1 A (at COM terminal)
Max. switching capacity	30 VA
Min. permissible load (P level, reference value)	10 mV, 10 μA
Mechanical life	50,000,000 times min. (at a switching frequency of 36,000 times/hr)
Electrical life (at an ambient temperature of 23°C)	100,000 times min. (at the rated load with a switching frequency of 1,800 times/hr)

Transistor Output

Rated load voltage	24 VDC
Max. load current	50 mA
Leakage current	100 μA max.

■ Communications Specifications

Item	RS-485
Transmission method	2-wire, half-duplex
Synchronization method	Start-stop synchronization
Baud rate	1,200/2,400/4,800/9,600/19,200 bps
Transmission code	ASCII
Communications	Reading/Writing to the K3GN
	Read/write set values, read/write scaling values, enable/disable the writing of data through communications, forced-zero control, and other data.

Refer to N102 Operation Manual for more details.

Connections

Terminal Arrangement

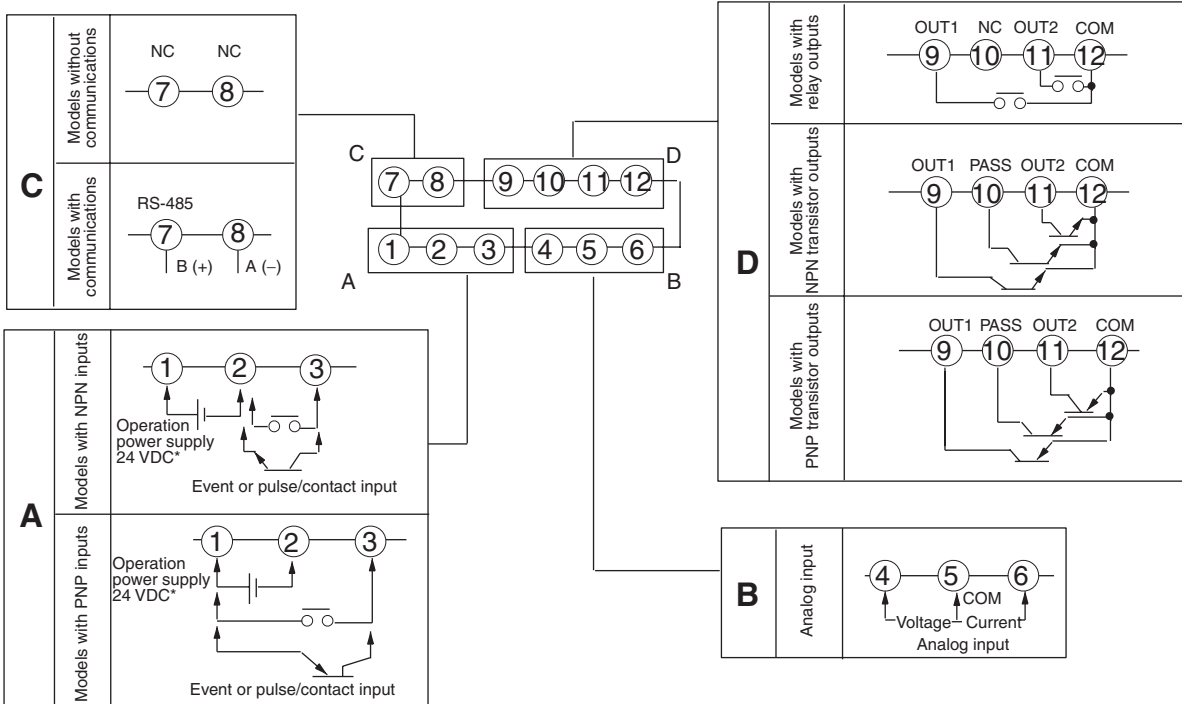
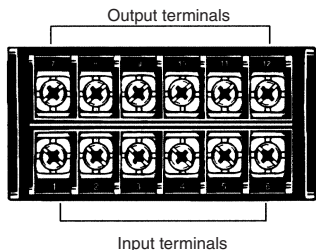

Note: *Operation power supply 24VDC: Recommended DC power supply: eg. OMRON s8VS

Terminal No.	Name	Description
①-②	Operation power	Connect the operation power supply.
③-②	Event input or pulse/contact input	Operates as follows depending on parameter setting: <ul style="list-style-type: none"> • Holds process value. • Calibrate the process value to zero and clear the forced-zero function. • Pulse or contact input.
③-①		
④,⑥-⑤	Analog input	Connect the voltage or current analog input.
⑦-⑧	Communications	RS-485 communications terminals.
⑨,⑪-⑫	Outputs	Outputs relay or transistor outputs. There is also a PASS output for models with transistor outputs.
⑨,⑩,⑪-⑫		

Panel indicators

Wiring

Block Diagram

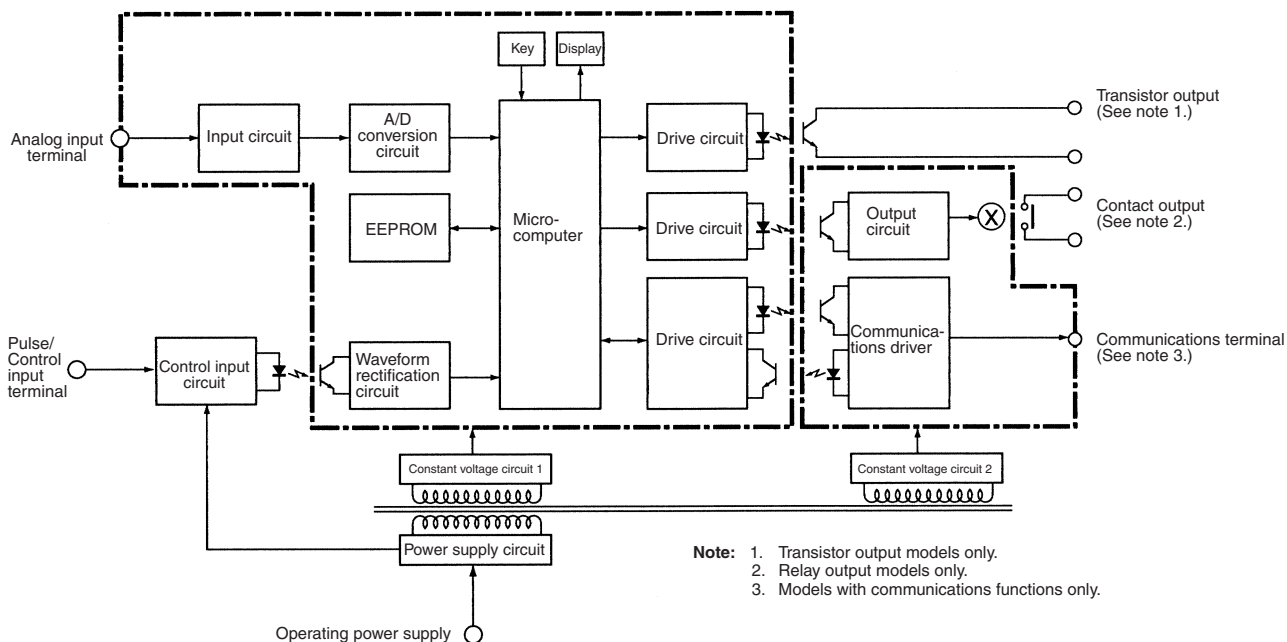

Note: 1. Transistor output models only.
 2. Relay output models only.
 3. Models with communications functions only.

Input Circuits

Analog Input (DC Voltage/Current)

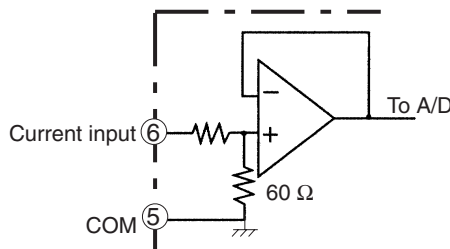
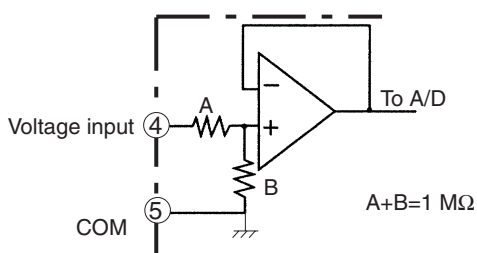

Pulse Input/Control Event Input (HOLD/ZERO)

NPN Input

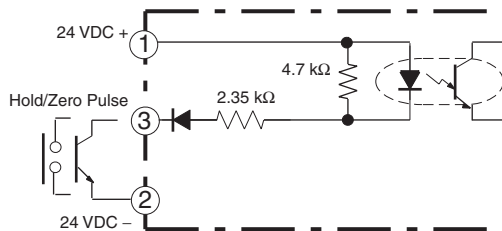

PNP Input

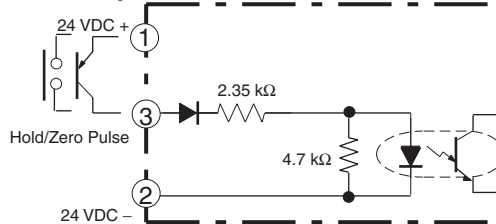

Output Circuits

Contact Output

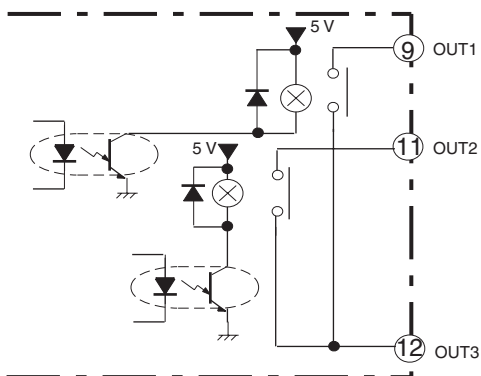

Transistor Output

NPN Output

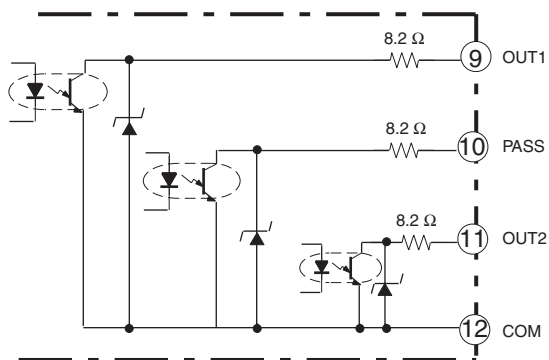

PNP Output

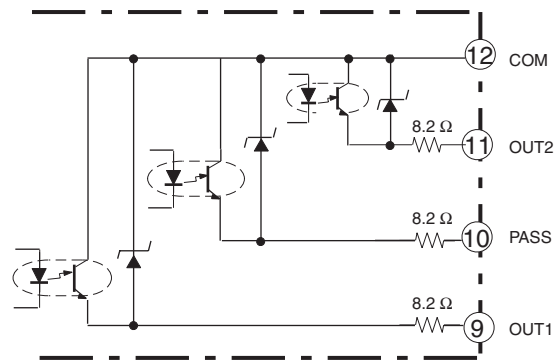

Panel indicators

Operation

■ Main Functions

Input Types and Ranges

Input type (setting parameter)	Function	Input range (setting parameters)	Setting range
Analog input (<i>RnRLG</i>)	Selects DC voltage/current signal input.	4 to 20 mA/0 to 20 mA (<i>4-20</i>) 1 to 5 V/0 to 5 V (<i>1-5</i>) ± 5 V (<i>5</i>) ± 10 V (<i>10</i>)	Displayable from -19999 to 99999 with scaling function. The position of the decimal point can be set as desired.
Pulse input (<i>PULSE</i>)	Selects pulse input signal.	0.05 to 30 Hz (<i>30</i>) 0 to 5 kHz (<i>5K</i>)	
Remote (<i>rnt</i>)	Displays digital data from PLC or PC.	---	

Scaling

Analog (Process) Inputs

The K3GN converts input signals into desired physical values.

INPUT2: Any input value

DISPLAY2: Displayed value corresponding to INPUT2

INPUT1: Any input value

DISPLAY1: Displayed value corresponding to INPUT1

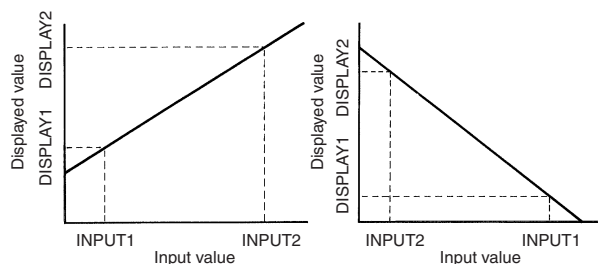

Example: When displaying the rotational speed (rpm) for a machine that generates 5 pulse signals per revolution, D is given by the following:

$$D = f \times 1/5 \times 60,$$

so if $f = 1$, then $D = 12$. Therefore, input 1 for $\bar{c}n^P$ and 12 for $d5P$.

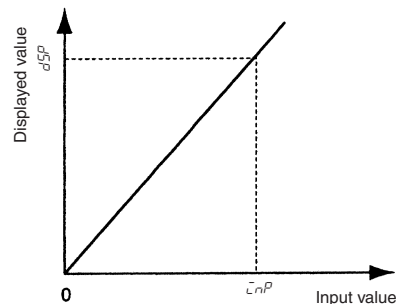

Pulse Frequency

The K3GN converts pulse signal inputs into desired units such as revolutions or rotational speeds.

The slope of the linear relationship between the input value and display value is calculated automatically when an input value and its corresponding display value are entered.

Input value: Any arbitrary input value

Display value: Desired display value corresponding to input value

If scaling for pulse signals is not performed, the input frequency will be displayed.

The relationship between input, f , and display, D , is expressed in the form $D = f \times a$ (multiplication factor). The value of a will vary according to the display unit. For example, if the display unit is rpm, Y is given by the following:

$$D = f \times 1/N \times 60 \text{ (i.e., } a = 1/N \times 60)$$

where N is the number of pulses per revolution and f is the input pulse frequency (Hz).

If the display unit is m/min, Y is given by the following:

$$D = f \times \pi d \times 1/N \times 60 \text{ (i.e., } a = \pi d \times 1/N \times 60)$$

where πd = the wavelength (m) per revolution.

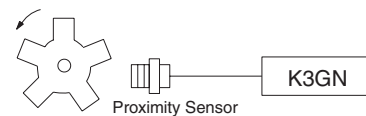

Average Processing

The average processing function stabilizes displayed values by averaging the corresponding input signals that fluctuate dynamically.

Hysteresis

The hysteresis of comparative outputs can be set to prevent the chattering of relay or transistor outputs.

Upper limit (high acting)

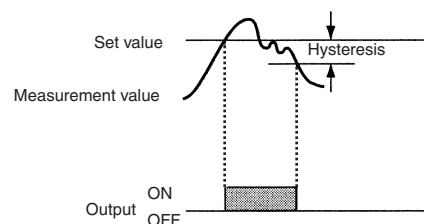

Startup Compensation Time (Pulse Input Only)

The startup compensation time parameter keeps the measurement operation from sending an unnecessary output corresponding to instantaneous, fluctuating input from the moment the K3GN is turned ON until the end of the preset period.

The compensation time can be set in a range from 0.0 to 99.9 seconds as the waiting time until the devices subject to measurement become stable after the startup of the power supply.

Changing the Display Color

The display can be programmed to change color when an output turns ON. In an example, the K3GN can be programmed to display Green for normal, and Red for errors. The color can be set to change from either green to red or red to green when output turns ON. K3GN can also be programmed to display only one unchanging color: Red or Green.

Teaching

An actual measured value as a set value without any front panel key input can be set with the teaching function. Teaching is useful for making settings while checking the operation status of K3GN.

Configurable Output Operating Action

Output 1 and output 2 can be set to operate in one of the 3 following modes:

- Upper limit (High Acting):
The output is turned ON when the measured value is greater than its set value.
 - Lower limit (Low Acting):
The output is turned ON when the measured value is less than its set value.
 - Upper and lower limits (Outside band Acting):
An upper limit (H set value) and lower limit (L set value) can be set independently.
The output is turned ON when the measured value is greater than upper-limit set value or less than the lower-limit set value.
- Only transistor outputs have a PASS output which is output when both OUT1 and OUT2 are OFF.

Upper Limit (High Acting)

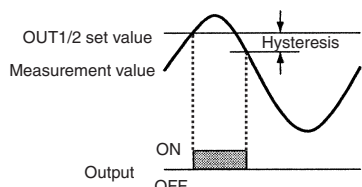

Lower Limit (Low Acting)

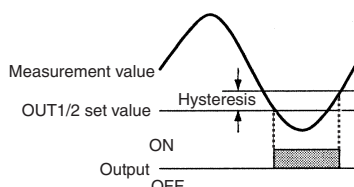

Upper and Lower Limits (Outside Band Acting)

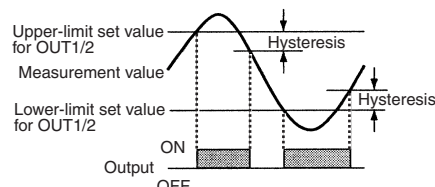

The three types of output operations shown above can be combined as desired. The following are examples of possible combinations.

Upper Limit 2-stage Output

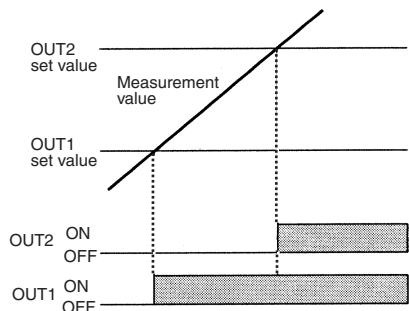

Threshold Output

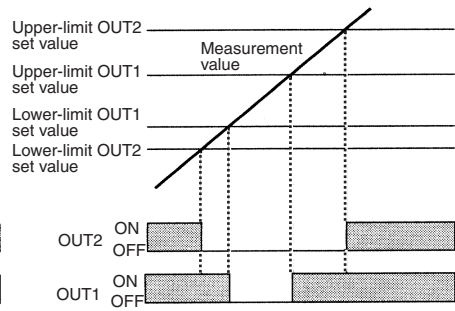

Combination of Upper Limit and Upper/Lower Limits

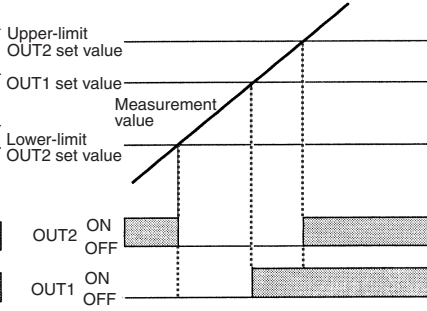

Forced-zero Function

It is possible to shift the zero point to a desired value (such as might be required when adjusting reference values) with one touch of the Up/Zero Key on the front panel.

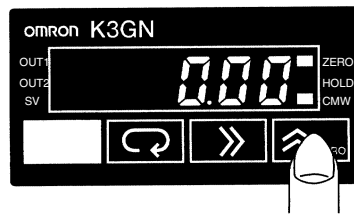

Nomenclature

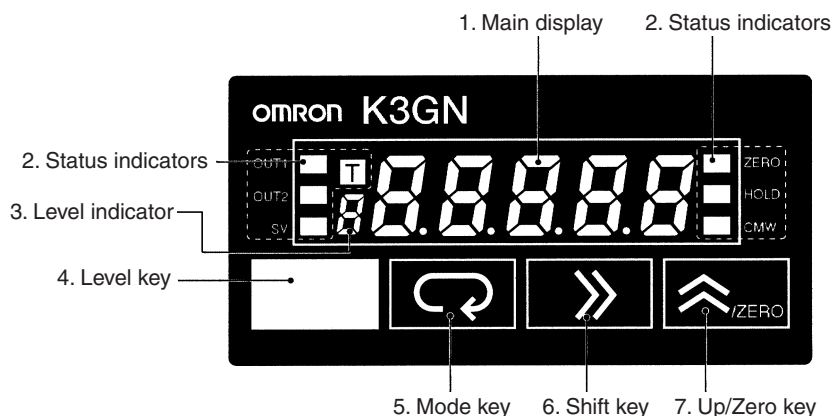

Name	Functions	
1. Main display	Displays process values, parameters, and set values.	
2. Status indicators	OUT1	Lit when output 1 is ON.
	OUT2	Lit when output 2 is ON.
	SV	Lit when a set value is being displayed or changed.
	T	Lit when the teaching function is enabled. Flashes when the K3GN is in teaching operation. Lit when a calibration value is being displayed during user calibration. Flashes while reading a calibration value.
	ZERO	Lit while the forced-zero function is activated.
	HOLD	Lit when HOLD input is ON.
	CMW	Lit when communications writing is "enabled" and is out when it is "disabled."
3. Level indicator	Displays the current level that the K3GN is in. (See below for details.)	
4. Level Key	Used to change the level.	
5. Mode Key	Used to allow the Main display to indicate parameters sequentially.	
6. Shift Key	Used to enable that set value to be changed. When changing a set value, this key is used to move along the digits.	
7. Up/Zero Key	Used to change a set value. Used to set or clear a forced-zero function when a measurement value is being displayed.	

Level indicator	Level
<i>P</i>	Protect
Not lit	Operation
<i>A</i>	Adjustment
<i>S</i>	Initial setting
<i>C</i>	Communications setting
<i>F</i>	Advanced function setting
<i>U</i>	User calibration

Dimensions

Note: All units are in millimeters unless otherwise indicated.

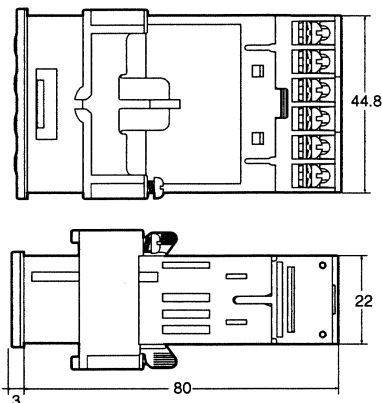
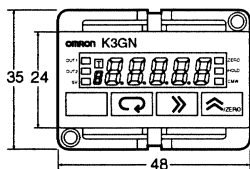

Panel Cutouts

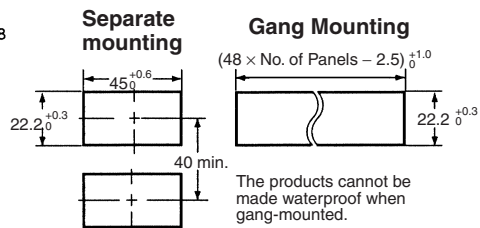

The K3GN uses M3 terminals. A terminal cover is provided.

Main Display Character Size

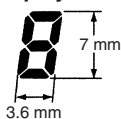

Application Examples

Detection of Dust Exhaust

The change in the density of the dust is detected via the E3SA and discriminated by the K3GN.

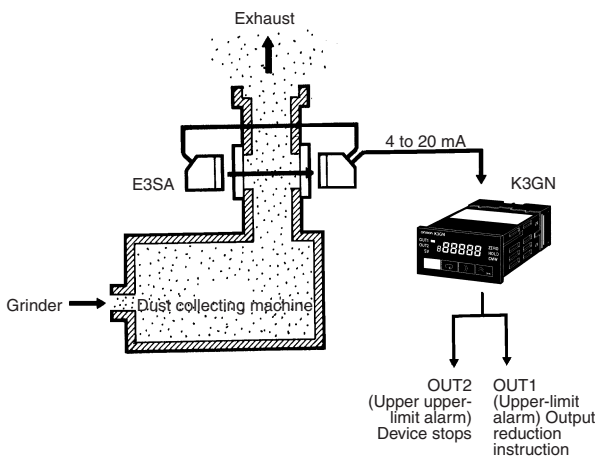

Monitoring of Tank Pressure

The output of the pressure sensor is processed and the pressure is displayed. Remote monitoring of the operation is possible with the communications function.

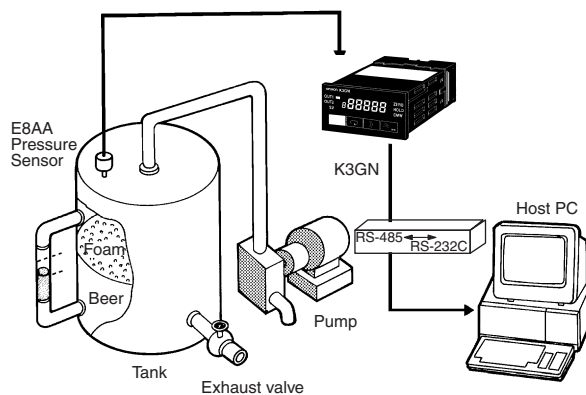

Monitoring of Motor Load Current

If the startup time compensation of the K3GN is enabled, the K3GN will not be influenced by the inrush current from starting the motor, and no signal will be output from the K3GN.

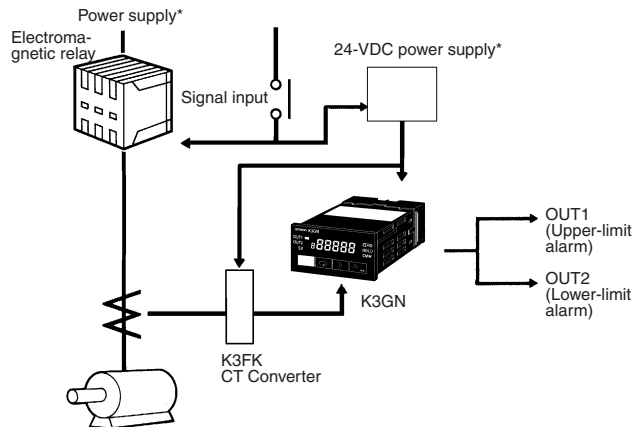

Note: *Power Supply: Recommended DC power supply: eg. OMRON S8VS.

Monitoring Difference between Two Line Speeds

The difference between the two line speeds is calculated by the PLC and the result is written via RS-485 to the K3GN where it is displayed.

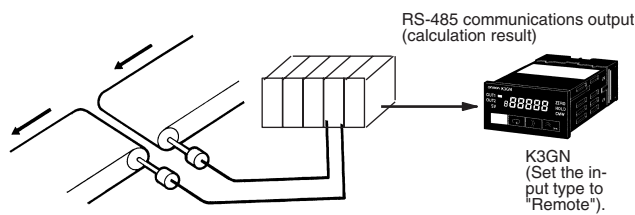

Position Indication on X-Y Table

The position on the X-Y table is calculated by the PLC and the result is written via RS-485 to the K3GN where it is displayed. The scaling function can be used to display the result in millimeter units.

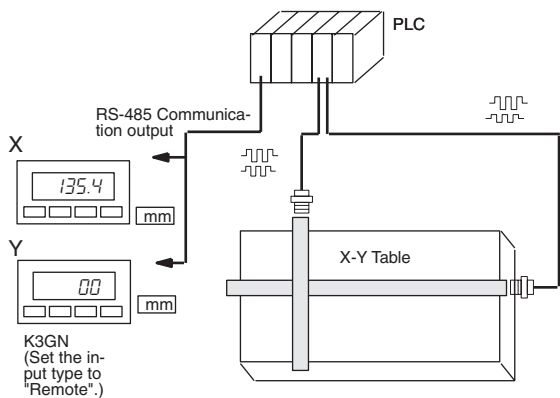

Monitoring the Remaining Quantity of Soup

The distance to the surface of the soup is detected with an ultrasonic sensor and, based on this distance, the K3GN displays the remaining quantity. When the remaining quantity of soup decreases to less than 20%, the K3GN lights the "Replenish" indicator.

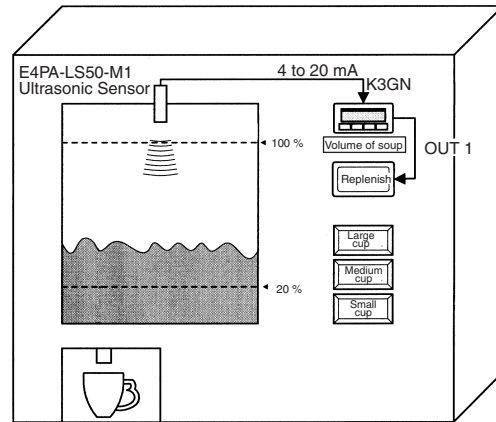

Monitoring Number of Motor Revolutions

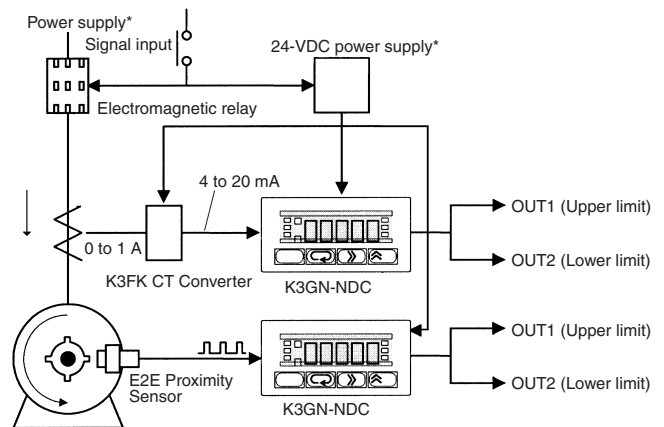

Note: *Power Supply: Recommended DC power supply: eg. OMRON S8VS.

Precautions

⚠ WARNING

Do not touch any of the terminals while power is being supplied. Doing so may result in electric shock. Also, do not touch the terminals with a screwdriver while power is being supplied. Electrical shock may result via the screwdriver.

⚠ Caution

Do not allow metal objects or conductive wire cuttings to enter the product. Doing so may result in electric shock, fire, or malfunction.

⚠ Caution

Do not attempt to disassemble, repair, or alter the product. Doing so may result in electric shock, fire, or malfunction.

⚠ Caution

Do not use the product where flammable or combustion gasses are present.

⚠ Caution

The lifetime of output relays varies greatly with the switching capacity and conditions. Consider the actual operating conditions, and use the product within the rated load and electrical service life.

⚠ Caution

Do not use loads exceeding the rated value. Doing so may result in damage or burning.

⚠ Caution

Use a power supply voltage within the specified ratings. Not doing so may result in damage or burning.

⚠ Caution

Be sure to tighten the terminal screws securely. The recommended tightening torque is 0.5 N·m. Loose screws may result in product failure or malfunction.

⚠ Caution

Perform correct setting of the product according to the application. Failure to do so may cause unexpected operation, resulting in damage to the unit or injury.

⚠ Caution

This product is not a safety device. Product failure may prevent operation of comparative outputs. Take safety measures, such as installing a separate monitoring system, to ensure safety and to prevent serious accidents caused by such failure, thus ensuring safety.

Observe the following precautions to ensure safety:

1. Do not connect anything to unused terminals.
2. Be sure to check each terminal for correct number and polarity before connection. Incorrect or reverse connection may damage or burn out internal components of the K3GN.
3. Do not use the product in locations subject to the following:
 - Dust or explosive gasses (e.g., sulfide gas or ammonia gas).
 - Condensation or icing as a result of high humidity.
 - Outdoors or in direct sunlight.
 - Splashing liquid or oil atmosphere.
 - Direct radiant heat from heating equipment.
 - Extreme changes in temperature.
4. Do not block heat dissipation around the product, i.e., provide sufficient space for heat dissipation. Do not block the ventilation holes on the back of the product.
5. Do not use paint thinner for cleaning. Use commercially available alcohol.

6. Use a power supply meeting the power supply specifications of the K3GN. Be sure that the rated voltage is achieved within 2 s after turning ON the power.
7. Use the K3GN within the specified temperature and humidity ranges. When installing the K3GN in a panel, be sure that the temperature around the K3GN (not the temperature around the panel) does not exceed 55°C. If the K3GN is subject to radiant heat, be sure that the temperature of the surface of the K3GN exposed to the radiant heat does not exceed 55°C by providing a fan or other heat removal method.
8. Store the K3GN within the specified temperature and humidity ranges.
9. Do not lay heavy objects on the product during use or storage. Doing so may deform or deteriorate the K3GN.
10. Conduct aging for 15 minutes min. after power is ON for correct measurement.

Mounting

Recommended panel thickness is 1 to 5 mm.

Insert the K3GN in the square cutout, insert the adapter from the back, and push the K3GN into the cutout as far as possible. Use screws to secure the K3GN. To make the K3GN waterproof, insert watertight packing in the K3GN.

Install the watertight packing in the proper direction. Note that the packing is direction-sensitive.

When gang-mounting two or more products in a cutout, be sure that the ambient temperature does not exceed the specifications.

Mount the K3GN as horizontally as possible.

Separate the K3GN from machines generating high-frequency noise, such as high-frequency welding machines and high-frequency sewing machines.

Operation

A K3GN model with a relay contact or transistor output may not output any alarm signal normally if the model has an error. It is recommended that an independent alarm device be connected to the model.

The parameters are factory-set so that the K3GN will operate normally. The settings of the parameters may be changed according to the application.

Wiring

Wire the power supply with the correct polarity. Wiring with incorrect polarity may result in damage or burning.

Wire the terminals using crimp terminals.

Tighten terminal screws to a torque of approx. 0.5 N·m.

Wire signal lines and power lines separately to reduce the influence of noise.

Use M3 crimp terminals of the type shown below.

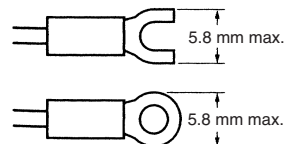

Operating Procedures

■ Initial Settings

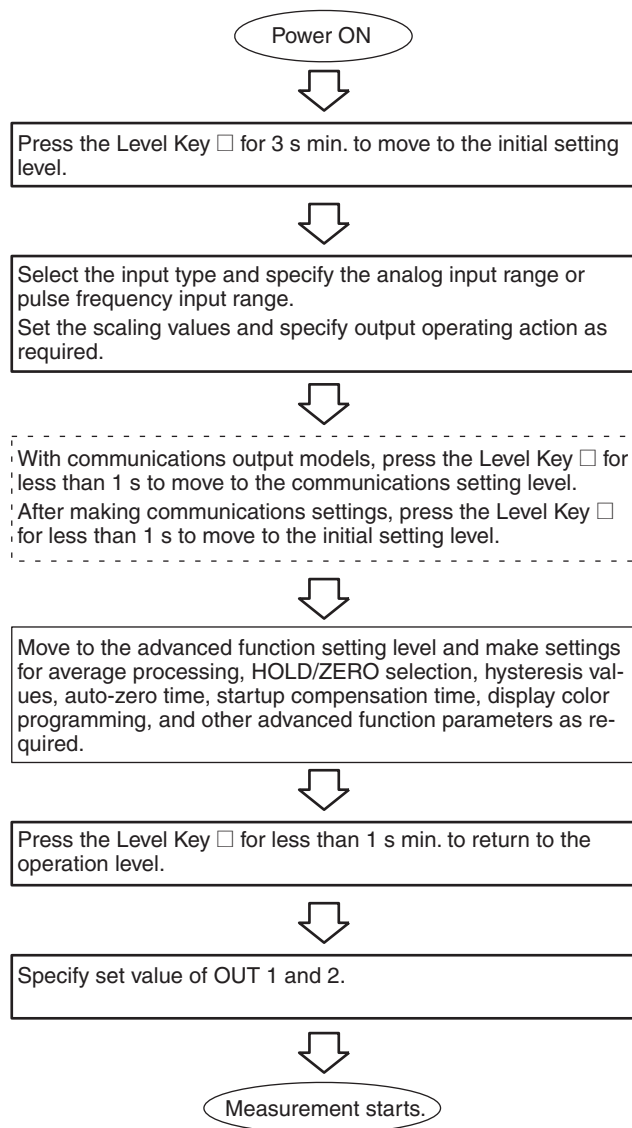

■ Levels

“Level” refers to a grouping of parameters. The following table lists the operations that are possible in each of the levels, and how to move between levels. There are some parameters that are not displayed for certain models.

Level name	Function	Measurement
Protect	Setting lockouts.	Continue
Operation	Displaying process values, setting/clearing forced-zero function, and setting OUT 1/2 set values.	Continue
Adjustment	Setting communications writing control.	Continue
Initial setting	Making initial settings of input type, scaling, output operating action, and other parameters.	Stopped
Communications setting	Setting baud rate, word length, and other communications data.	Stopped
Advanced function setting	Setting average processing, display color settings, and other advanced function parameters.	Stopped
Calibration	Setting user calibration of the inputs.	Stopped

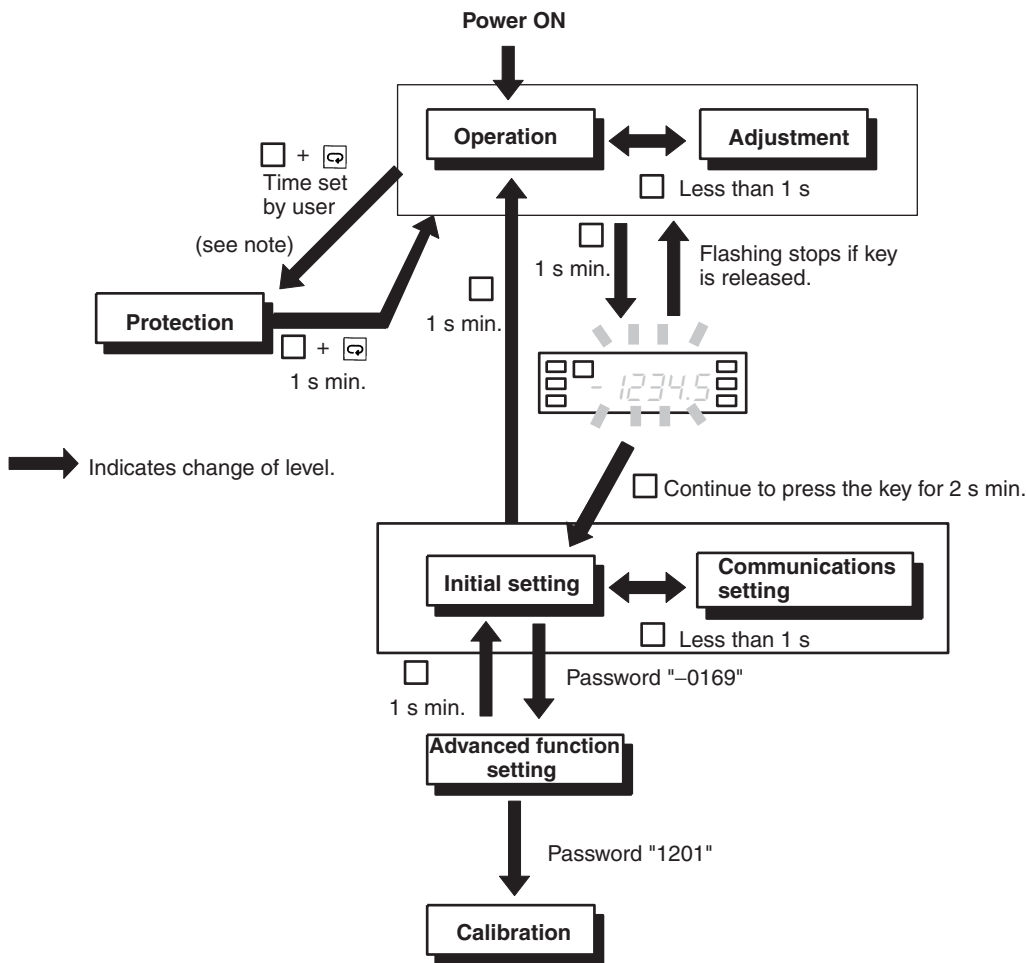

Note: The move to protection level time can be set in the advanced function setting level.

Parameters

- Note:**
1. Some parameters are not displayed for certain models.
 2. The K3GN will stop measurement if the level is changed to the initial setting level, the advanced function setting level, the communications setting level, or the calibration level.
 3. If the input range is changed, some parameters are set to default values. Therefore, set the input range first.
 4. Settings displayed in reverse black/white are defaults.

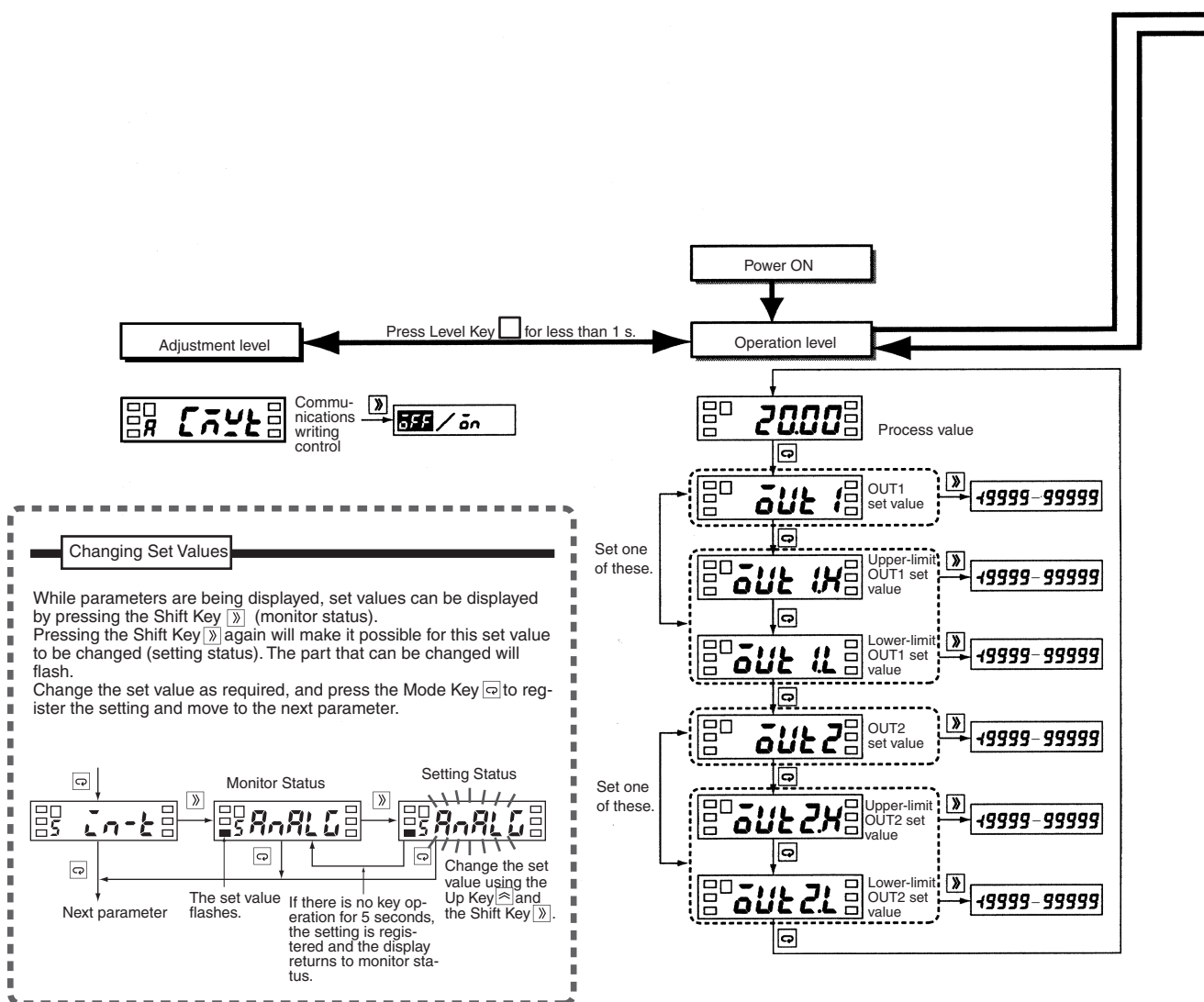

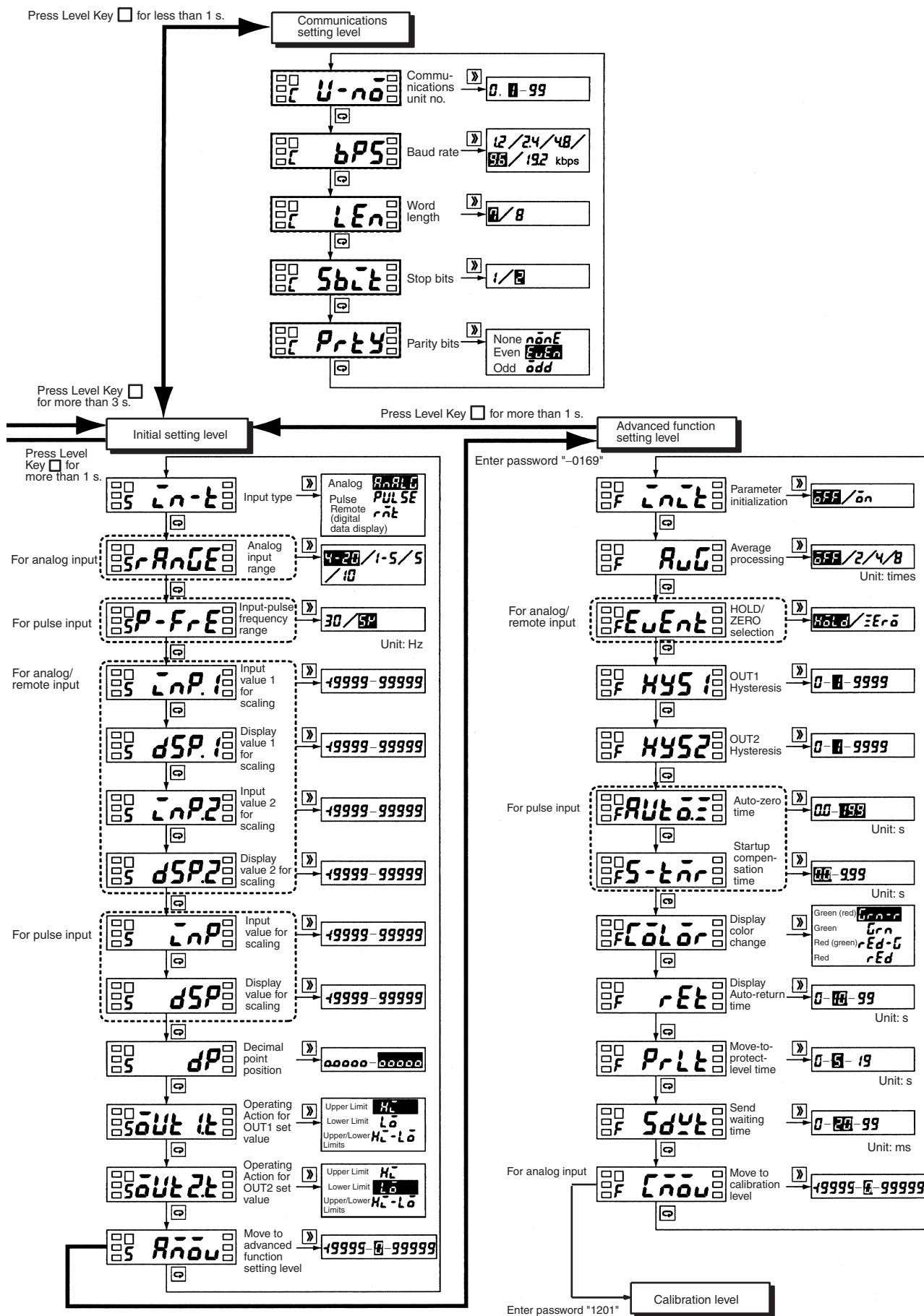

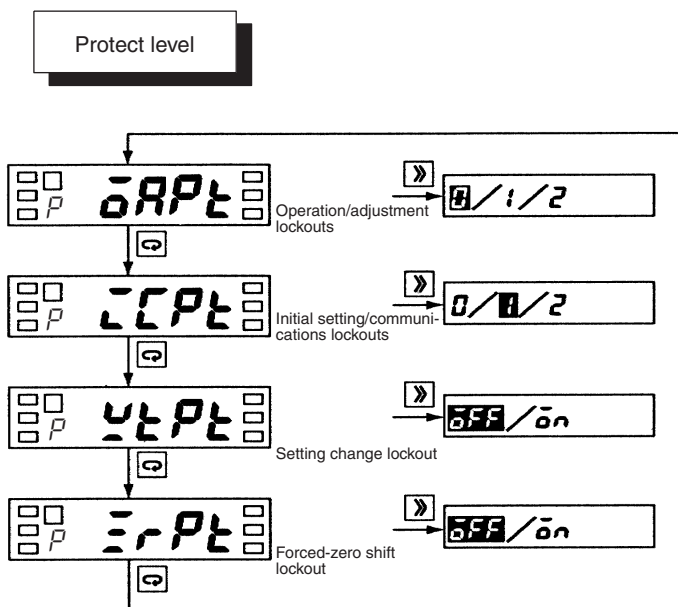

- Prohibits menu display, writing, etc., for operation level and adjustment level.
- Prohibits access to menu display, initial setting level, communications setting level, and advanced function setting level.
- Prohibits setting changes using front panel keys.
- Prohibits use of the forced-zero function using front panel keys.

Operation/Adjustment Lockouts

Prohibits key operations for operation level and adjustment level.

Setting	Operation level		Moving to adjustment level
	Process value display	Set value display	
0	Allowed	Allowed	Allowed
1	Allowed	Allowed	Prohibited
2	Allowed	Prohibited	Prohibited

- Initial setting is 0.
- When the set value is 0 (the initial setting), protection is not set.

Setting Change Lockout

Prohibits setting changes.

Setting	Meaning
OFF	Setting changes using front panel keys allowed (i.e., it is possible to move to the state where changes to settings can be made).
ON	Setting changes using front panel keys prohibited (i.e., it is not possible to move to the state where changes to settings can be made).

- The initial setting is OFF.

Note: Changes to protection level parameters, moving to advanced function setting level, and moving to calibration level are all allowed.

Initial Setting/Communications Lockouts

Prohibits moving to the initial setting level, the communications setting level, and the advanced function setting level.

Setting	Moving to initial setting level	Moving to communications setting level
0	Allowed (message for moving to advanced function setting level displayed)	Allowed
1	Allowed (message for moving to advanced function setting level not displayed)	Allowed
2	Prohibited	Prohibited

- The initial setting is 1.

Forced-zero shift Lockout

Prohibits the setting or clearing of a forced-zero using the front panel key.

Setting	Meaning
OFF	Executing and clearing of forced-zero allowed.
ON	Executing and clearing of forced-zero prohibited.

- The initial setting is OFF.

■ Troubleshooting

When an error occurs, error details will be displayed on the main display. Confirm the error from the main display and take the appropriate countermeasures.

Main display	Level display	Error contents	Countermeasure
E 1111 (E111)	Not lit	RAM memory error	Turn the power supply OFF and ON again. If the same error is displayed even after the power is turned OFF and ON, it is necessary to replace the memory. If normal operation is restored by turning the power supply OFF and ON, it is possible that there is noise interference. Check that there is nothing in the vicinity that may be the source of noise.
E 1111 (E111)	5	EEPROM memory error	
5.Errr (S.Err) (Flashes at 0.5-s intervals)	Not lit	Input error or input range exceeded	All outputs turn OFF. Check for incorrect input wiring, for disconnected power lines, for short-circuiting, and the input type. Bring the input value within range.
99999 (Flashes at 0.5-s intervals)	Not lit	Greater than displayable range	This is not an operational error. These messages are displayed when a value to be displayed lies outside the displayable range, even if the input value is within the input range and the range for which measurement is possible. Bring the input value and display value within range.
- 19999 (Flashes at 0.5-s intervals)	Not lit	Less than displayable range	

Additional Information

■ Application as a Process Meter

The initial settings required when using the K3GN as a process meter are explained below using the following example.

Setting Example

Inputs in the range 1 to 5 V are scaled to the range 0 to 100.0 kg and displayed. If the measurement value goes over 70.0 kg, output 1 turns ON. If the measurement value goes below 50.0 kg, output 2 turns ON.

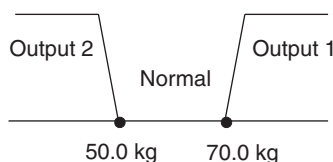
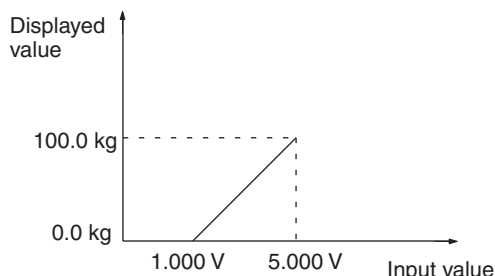

Initial Setting Procedure

- 1. Check the wiring and turn ON the power.**
- 2. Set analog input as the input type.**
If a measurement value is displayed (operation level), move to the initial setting level by holding down the Level Key for 3 s min.
Set parameter \overline{CnT} to $RnALG$.
- 3. Set the analog range to 1 to 5 V.**
Set parameter $rRnGE$ to $1-5$.
- 4. Set the scaling values.**
Set parameter $\overline{CnP.1}$ to 1.000 .
Set parameter $dSP.1$ to 0 .
Set parameter $\overline{CnP.2}$ to 5.000 .
Set parameter $dSP.2$ to 100.0 .
- 5. Set the position of the decimal point.**
Set parameter dP to 0000.0 .
- 6. Operating action for OUT1 and OUT2 set values.**
Set parameter $\overline{OUT.1E}$ to $H\overline{C}$.
Set parameter $\overline{OUT.2E}$ to $L\overline{C}$.
- 7. Set OUT1 set value to 70.0 and OUT2 set value to 50.0.**
If an initial setting level parameter is displayed, press the Level Key for 1 s min. to return to the operation level.
Set parameter $\overline{OUT.1}$ to 70.0 .
Set parameter $\overline{OUT.2}$ to 50.0 .
- 8. Start actual operation.**

■ Application as a Tachometer

The initial settings required when using the K3GN as a tachometer are explained below using the following example.

Setting Example

The speed of a conveyor belt is displayed in m/min units. For every revolution of the shaft, 4 pulses are output. The diameter of the axis of rotation is 12 cm. If the Rotational speed goes over 10.500 m/min, output 1 turns ON. If the speed goes below 9.500 m/min, output 2 turns ON.

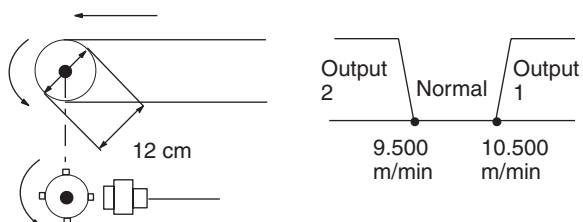

$$\text{Speed (m/min)} = 5654.866... \times \text{Input frequency (Hz)}$$

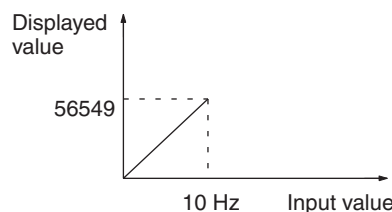

To limit inaccuracies due to scaling, select a round number (e.g., 10) as the input value and select a display value of as many digits as possible. In this example, scaling is performed so that an input value of 10 gives a displayed value of 56549.

Deciding the Scaling Value

$$\text{Rotational speed (m/min)} = \pi \times \text{Diameter (m)} \times \text{Revolutions per minute (rpm)}$$

$$\text{Revolutions per minute (rpm)} = \text{Input frequency (Hz)} \div \text{Number of pulses per revolution} \times 60$$

Applying the appropriate values to these 2 equations gives: Speed (m/min) = 5.654866... × Input frequency (Hz)

Multiply by 1,000 to display the first 3 digits to the right of the decimal point.

Initial Setting Procedure

1. Check the wiring and turn ON the power.

2. Set pulse input as the input type.

If a measurement value is displayed (operation level), move to the initial setting level by holding down the Level Key for 3 s min.

Set parameter $\overline{Cn-1}$ to *PULSE*.

3. Set the pulse frequency to 30 Hz.

The input pulse frequency for the application is approximately 2 Hz and so can be assumed not to exceed 30 Hz. Set parameter $\overline{P-FRE}$ to *30*.

4. Set the scaling values.

Set parameter \overline{CnP} to *10*.

Set parameter \overline{dSP} to *55549*.

5. Set the decimal point.

Set parameter \overline{dP} to *00.000*.

6. Operating action for OUT1 and OUT2 set values.

Set parameter $\overline{OUT-1}$ to *H.L.*

Set parameter $\overline{OUT-2}$ to *L.O.*

7. Set OUT1 set value to 10.500 and OUT2 set value to 9.500.

If an initial setting level parameter is displayed, press the Level Key for 1 s min. to return to the operation level.

Set parameter $\overline{OUT-1}$ to *10.500*.

Set parameter $\overline{OUT-2}$ to *9.500*.

8. Start actual operation.

ALL DIMENSIONS SHOWN ARE IN MILLIMETERS.

To convert millimeters into inches, multiply by 0.03937. To convert grams into ounces, multiply by 0.03527.

Cat. No. N101-E1-03

In the interest of product improvement, specifications are subject to change without notice.



SCATTERGOOD & JOHNSON LTD

ELECTRICAL ENGINEERING & FLUID CONTROL DISTRIBUTORS

Est.1899

At Scattergood & Johnson Ltd, we pride ourselves on being a technical distributor to specialist industries.

Working with a range of quality product suppliers across a number of specialist markets, we are not your average 'box shifter' - we are your technical and supply chain partner.

We fully support every product we sell - for free! Our internal team and external sales engineers can answer any product or application question, no matter the complexity.

Backing up this technical ability is a range of 50,000+ products available from stock for nationwide next day delivery (same day if required!), or you can collect what you need from any of our trade counters around the UK.

Select your specialist interest below to learn more about how we can help.

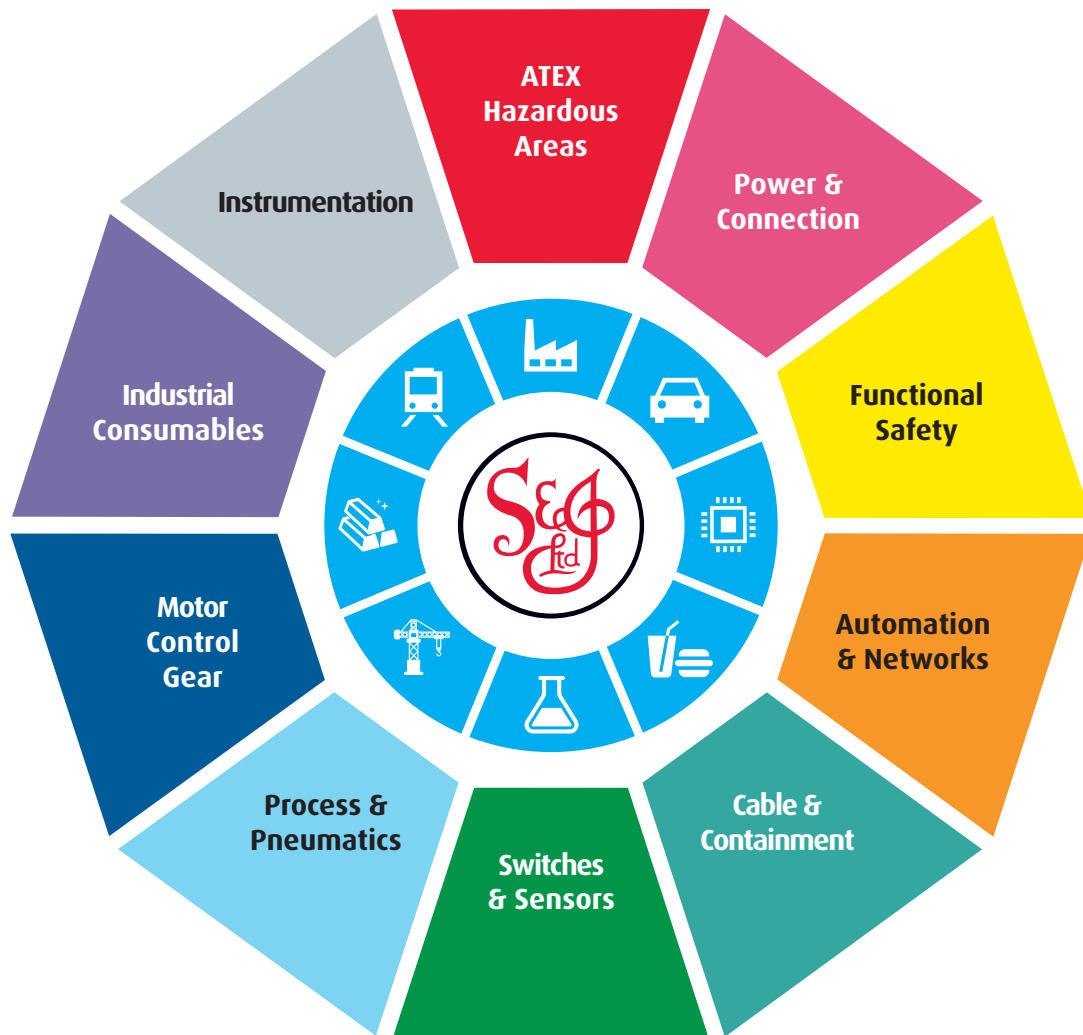

Online, In Branch and On the Road - Scattergood & Johnson Ltd, there when you need us.

www.scatts.co.uk