

New Value For Control Panels

Power Monitors

KM-N2 / KM-N3

**Multi-circuit Power Monitors for Energy Management
Easily Implement All Types of Power Monitoring
with On-panel and In-panel Installation**



- Power Monitors applicable around the globe
- Solve design, installation, and operation topics with one model for each installation type
- Handle circuits up to 3-phase 4-wire and 3-phase 480 V

New Value For Control Panels

Control Panels: The Heart of Manufacturing Sites.

Evolution in control panels results in large evolution in production facilities.

And if control panel design, control panel manufacturing processes, and human interaction with them are innovated, control panel manufacturing becomes simpler and takes a leap forward.

OMRON will continue to achieve a control panel evolution and process innovation through many undertakings starting with the shared Value Design for Panel *1 concept for the specifications of products used in control panels.



*1 Value Design for Panel

Our shared Value Design for Panel (herein after referred to as "Value Design") concept for the specifications of products used in control panels will create new value to our customer's control panels.

Combining multiple products that share the Value Design concept will further increase the value provided to control panels.

Further Evolution
for
Panels

**New Value
For
Control Panels**

Innovation for
panel building
Process

Simple & Easy
for panel business
People

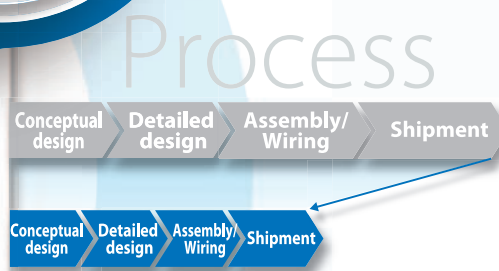

Panels

Process

People



Multi-circuit Power Monitors for Energy Management

Easily Implement All Types of Power Monitoring with On-panel and In-panel Installation

The New KM-N2 and KM-N3 Power Monitors

Energy management starts by continuously monitoring power.

The KN-N2 and KN-N3 enable all types of power measurement with easy installation and easy system construction.

You can mount them on or in control panels and distribution boards and take advantage of their compatibility with power supplies around the world.

Multi-circuit measurements

Three-phase 4-wire	1-circuits
Three-phase 3-wire	2-circuits
Single-phase 3-wire	
Single-phase 2-wire	4-circuits

**Single-phase 100 V to
Three-phase 480 V**

**General-purpose CT
(1 A or 5 A)**



Packed Full of Functions!

**Modbus (RTU)
(RS-485)**

**Four Total Power
Consumption Pulse Outputs**

**IEC Class 0.5S
Accuracy**

**Corresponding
to the Main
International Standards**

Features Common to Both the KM-N2 and KM-N3

Power Monitors for Energy Management That

Easier Application and Greater Work Efficiency for Everyone

System Design Manager

Handle All EMS* Specifications



Energy Manager

No Numeric Value

*EMS: Energy Management System

General-purpose CTs



Corresponding to the Main International Standards



Many Host Communications Methods

PLC Proprietary systems Central monitoring system



RS-485 communications
Modbus(RTU)
CompoWay/F

Total power consumption
pulse outputs

Large Easy-to-read Displays

Actual Size



Multi-address System



Setting	Automatic assignment	Setting	Automatic assignment	Setting
02	03	04	05	09
Three-phase, 3-wire	Three-phase, 3-wire	Single-phase, 3-wire	Single-phase, 2-wire	Three-phase, 4-wire

DIN Rail Installation Type KM-N2



Solve Design, Installation, and Operation Issues

Overlooked 

Installation Manager
Efficient Wiring 



On-panel Installation Type KM-N3



Push-In Plus Terminal Block

The structure of Push-In Plus terminal blocks helps reduce wiring mistakes with easy-to-insert terminals that hold wires firmly (RS-485 communications and pulse output terminals).



Efficient Initial Setting Tool*1

- Easy-to-use setting functions of the communications and measurement conditions
- Save/Load setting by CSV file

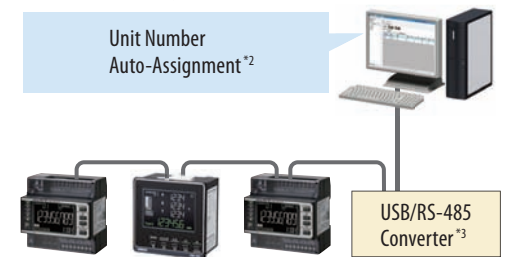

*1. Supported Version of main unit: V2.0.0 or higher for all models.

*2. Except for KM-N2-FLK.

*3. For this software, compatibility of the USB/RS-485 converter has been verified for SI-35USB (LINEEYE Co.,Ltd.). K3SC-10 is not compatible.

Wiring Error Detection

ALARM lamp blinks



KM-N2

! lamp lights up



KM-N3

Power Monitor

KM-N2-FLK

Global Power Monitor for Mounting
Inside Control Panels

- Solve design, installation, and operation topics.
- You can measure up to four circuits with one Power Monitor.
- Use general-purpose CTs and handle a variety of worksites.
- Large, easy-to-read white LCD for improved visibility.
- IEC Class 0.5S high-precision measurements (Power Monitor only).



Refer to Safety Precautions on page 19.

For the most recent information on models that have been certified for safety standards, refer to your OMRON website.

Ordering Information

Power Monitor

Model	Applicable phase wiring methods	Power supply voltage	Dimensions	Communications
KM-N2-FLK	Single-phase, 2-wire: 100 to 277 VAC Single-phase, 3-wire: 100 to 240 VAC (L-N) or 200 to 480 VAC (L-L) Three-phase, 3-wire: 173 to 480 VAC (L-L) Three-phase, 4-wire: 100 to 277 VAC (L-N) or 173 to 480 VAC (L-L)	Same as measured circuits: 100 to 277 VAC (L-N) 173 to 480 VAC (L-L)	90 x 90 x 65 mm (HxWxD)	RS-485 communications, pulse output

To use a commercially available current transformer, use a CT with a secondary current rating of 1 A or 5 A, and a rated load of at least 1.0 VA.

Split Type Current Transformer (CT) (CE marking compliant KM-N2/N3 dedicated products *)

Model	Rated primary current	Rated secondary current
KM-NCT-E100A	100 A	1 A
KM-NCT-E250A	250 A	
KM-NCT-E500A	500 A	

* The KM-NCT-E conforms to the standards shown above ONLY when it is used with a power monitor KM-N2-FLK or KM-N3-FLK to which it is attached. Use of the KM-NCT-E without a power monitor does not conform to these standards.

Note: Select a CT cable that does not exceed the rated load of 1 VA.

Specifications

Ratings (Power Monitor)

Item	Model	KM-N2-FLK
Applicable phase wiring methods		Single-phase two-wire, single-phase three-wire, three-phase three-wire, and three-phase four-wire
Number of measured circuits		Single-phase two-wire: 4 circuits max., Single-phase three-wire or three-phase three-wire: 2 circuits max., Three-phase four-wire: 1 circuit
Power consumption		7 VA max.
Input	Rated input voltages (power supply voltages)	Single-phase, 2-wire: 100 to 277 VAC Single-phase, 3-wire: 100 to 240 VAC (L-N) or 200 to 480 VAC (L-L) Three-phase, 3-wire: 173 to 480 VAC (L-L) Three-phase, 4-wire: 100 to 277 VAC (L-N) or 173 to 480 VAC (L-L)
	Allowable supply voltage range	85% to 115% of rated power supply voltage
	Connectable CTs	General-purpose CT with a rated secondary current of 1 A or 5 A *
	Maximum CT secondary current	6 A
	Rated input frequency	50/60 Hz
Ambient operating temperature		-25 to 55°C (with no condensation or icing)
Ambient operating humidity		25% to 85%
Storage temperature		-25 to 85°C (with no condensation or icing)
Storage humidity		25% to 85%
Operating altitude		2,000 m max.
Installation environment		Overvoltage category II, measurement category II, pollution degree 2
Electromagnetic environment		Industrial electromagnetic environment (EN/IEC 61326-1 Table 2)
Compliant standards		EN 61010-2-030, EN 61326-1, and UL 61010-1

* The KM-series CTs (the KM20-CTF or KM-NCT Series) cannot be used. Use general-purpose CTs with a secondary-side output of 1 A or 5 A.

Split Type Current Transformer (CT) (CE marking compliant KM-N2/N3 dedicated products *)

Item	KM-NCT-E100A	KM-NCT-E250A	KM-NCT-E500A
Rated primary current: In	100 A	250 A	500 A
Rated secondary current: Is	1 A		
Rated frequency	50/60 Hz		
Cable Length	Please refer to <i>Writing to KM-NCT-E□□□A</i>		
Rated load	1 VA		
Insulation resistance	100 MΩ min. (at 500 VDC mega) between core and all output terminals		
Dielectric strength voltage	2300 VAC, 1 minute between core and all output terminals.		
Weight	Approx. 170 g	Approx. 175 g	Approx. 290 g
Maximum wire diameter	24 dia.	24 dia.	36 dia.
Operating temperature and humidity range	-20 to 55 °C, relative humidity: 85% max. with no condensation		
Storage temperature and humidity range	-30 to 90 °C, relative humidity: 85% max. with no condensation		
Applicable standards *	EN61010-1, EN61010-2-030, EN61326-1		
Installation environment	Overvoltage category and measurement category: II, Pollution level: 2		

* The KM-NCT-E conforms to the standards shown above ONLY when it is used with a power monitor KM-N2-FLK or KM-N3-FLK to which it is attached. Use of the KM-NCT-E without a power monitor does not conform to these standards.

Wiring to KM-NCT-E□□□A

- For wiring of the output terminal of CT, use AWG18-14 electric wire (with a cross-section of 0.75-2.0 mm²) and Y-shape terminal compatible with the M3 screw.
- The recommended torque for screwing the M3 screws onto the output terminal is 0.3 N·m. Make sure the Y terminal is pushed all the way in and tightened firmly. After fixing the wiring, confirm that the wire is fixed securely.
- The guideline of the maximum wiring length between KM-N2-FLK or KM-N3-FLK and KM-NCT-E is as follows.
The longer the wire length, the larger the measurement error using the KM-NCT-E becomes.
- The limit of the wiring length can also be calculated by the following formula. Calculate the wiring length limit according to the conductor resistivity of the wiring and keep the wiring length below the limit.
- The limits of the wiring length shown below are for reference only. They do not guarantee proper use.

Wiring diameter	Guideline for wiring length limit
0.75 mm ² (AWG18 equivalent)	15 m
2.0 mm ² (AWG14 equivalent)	43 m

$\text{Wiring extension limit value (one-way) (m)} = \frac{0.475}{\text{conductor resistivity } (\Omega/\text{m})}$

Note: Select a CT cable that does not exceed the rated load of 1 VA.

Performance (Power Monitor)

Item	Model	KM-N2-FLK
Measured items		Total power consumption (active, regenerative, and reactive), power (active and reactive), current, voltage, power factor, and frequency
Measurement specifications	Active power	0.5% (IEC 62053-22 class 0.5S) *
	Reactive power	2% (IEC 62053-23 class 2) *
	Sampling cycle	80 ms for 50 Hz and 66.7 ms for 60 Hz
Insulation resistance		(1) Between all electrical circuits and the case: 20 MΩ min. (at 500 VDC) (2) Between all power supply and voltage inputs and all communications and pulse output terminals: 20 MΩ max. (at 500 VDC)
Dielectric strength		(1) Between all electrical circuits and the case: 2,200 VAC for 1 min (2) Between all voltage and current inputs and all communications and pulse output terminals: 2,200 VAC for 1 min
Vibration resistance		Single amplitude: 0.1 mm, Acceleration: 15 m/s ² , Frequency: 10 to 150 Hz, 10 sweeps for 8 min each along three axes
Shock resistance		150 m/s ² , 3 times each in 6 directions (up/down, left/right, forward/backward)
Indications and operation method		LED/LCD indications and operation buttons
Weight		Approx. 350 g (Power Monitor only)
Degree of protection		IP20
Pulse output	Number of outputs	Number of outputs: 4 (photoMOS relay outputs) Used for the total power consumption pulse output.
	Output capacity	50 mA at 40 VDC ON residual voltage: 1.5 V max. (for output current of 50 mA) OFF leakage current: 0.1 mA max.
	Output unit	Output unit: 1, 10, 100, 1k, 5k, 10k, 50k, or 100k (wh) Pulse ON time: 500 ms (Cannot be changed.)
Communications interface	Communications method	RS-485 (2-wire half-duplex with start-stop synchronization)
	Communications protocol	Modbus (RTU): Binary. CompoWay/F: ASCII
	Baud rate	1.2, 2.4, 4.8, 9.6, 19.2, or 38.4 kbps
	Data length	Data length: 7 or 8 bits Stop bits: 1 or 2 bits Vertical parity: Even, odd, or none
	Maximum transmission distance	1,200 m
	Maximum number of connected Power Monitors	Modbus: 99, CompoWay/F: 31 If you measure more than one circuit with one Power Monitor, the number of circuits is treated as the number of connected Power Monitors.
Dimensions (H×W×D)		90 × 90 × 65 mm (excluding protrusions)
Installation method		DIN Rail mounting
Accessories		Instruction Manual and Compliance Sheet

* The error of the CT or VT is not included. IEC 62053 is an international standard for power metering.

KM-N2-FLK

Part Names and Functions

Power Monitor

Front Panel with Terminal Block Covers Removed

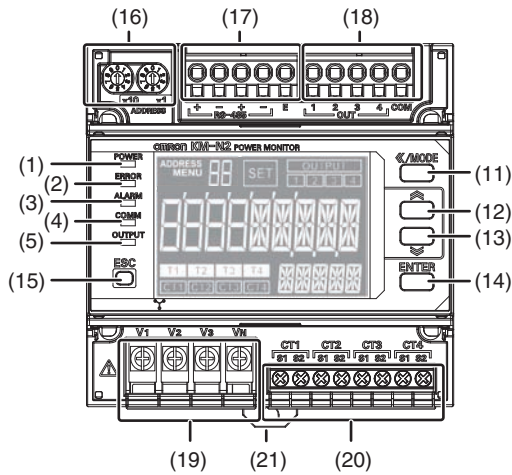

Detailed View of LCD

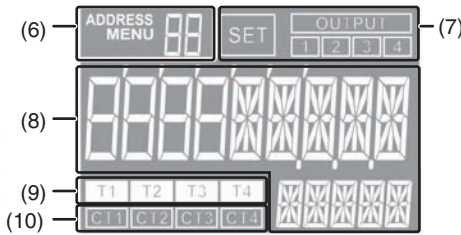

Side View

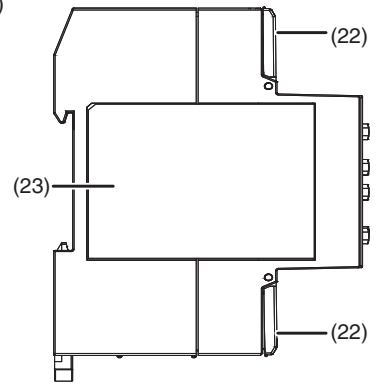

No.	Item	Description	
(1)	Power indicator (green)	Lights when the power supply is turned ON.	
(2)	Error indicator (red)	Flashes when there is an abnormality, such as a failure.	
(3)	Alarm indicator (orange)	Flashes when there is an alarm.	
(4)	Communications indicator (yellow)	Lit during communications.	
(5)	Pulse indicator (yellow)	Lit while pulses are being output from OUT1 (circuit A).	
(6)	Communications address and menu display	When ADDRESS is lit (Measurement Mode), the communications address is being displayed. When MENU is lit (Setting Mode), the menu number is being displayed.	
(7)	Status Indicators	SET	Lit in Setting Mode.
		OUTPUT	Lit while a pulse output is being set up.
		1	Lit while pulses are being output from OUT1.
		2	Lit while pulses are being output from OUT2.
		3	Lit while pulses are being output from OUT3.
(8)	Measured value/set value display	Main display	Displays the measured value or set value.
		Sub display	Displays the measurement unit or setting name.
(9)	Tariff display	Displays the tariff number (T1 to T4) a total active power consumption is being saved.	
(10)	CT usage display	Displays the numbers of the CTs (CT1 to CT4) for which measurement or setting operations are in progress.	
(11)	<</MODE Key	Short press: Changes the circuit or moves the digit. Long press: Changes the mode.	
(12)	▲ Key	Increments the item or value.	
(13)	▼ Key	Decrements the item or value.	
(14)	ENTER Key	Enters the item or value.	
(15)	ESC Key	Cancel	
(16)	Rotary switches	Set the communications address for circuit A. The left switch (x10) sets the tens place and the right switch (x1) sets the ones place.	
(17)	RS-485 communications terminals	RS-485 + (1)	RS-485 + terminal
		RS-485 - (1)	RS-485 - terminal
		RS-485 + (2)	RS-485 + terminal for crossover wiring
		RS-485 - (2)	RS-485 - terminal for crossover wiring
		RS-485 E	RS-485 terminating resistance terminal
(18)	Pulse output terminals	OUT1	Pulse output terminal for circuit A
		OUT2	Pulse output terminal for circuit B
		OUT3	Pulse output terminal for circuit C
		OUT4	Pulse output terminal for circuit D
		COM	Pulse output common terminal
(19)	Voltage input terminals	Terminal used to input the power supply voltage. These terminals are also used for the measured voltage inputs.	
(20)	CT input terminals	Terminals used to connect the CT cables for CT1 to CT4	
(21)	DIN hook	Hook used to mount the Power Monitor to a DIN Track	
(22)	Terminal block covers	Sealed terminal block covers	
(23)	Terminal arrangement label	Label that provides information, such as the model number, power supply voltage, terminal arrangement, and serial number	

Connection Wiring Diagrams

Three-phase, Four-wire Circuit

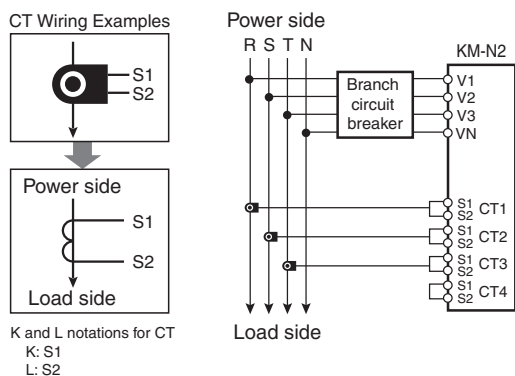

Single-phase, Two-wire Circuit Branched from Single-phase, Three-wire Circuit

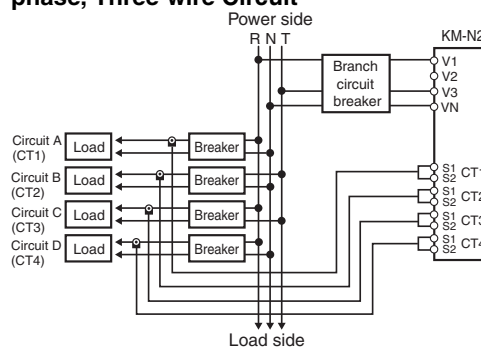

Single-phase, Three-wire Circuit

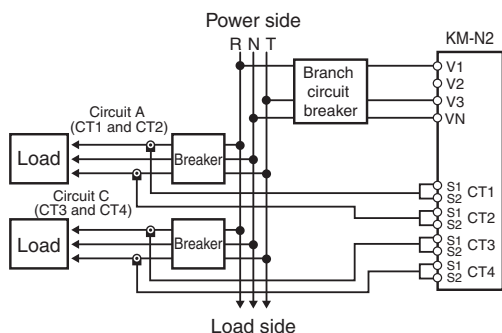

Single-phase, Three-wire Circuit and Single-phase, Two-wire Circuit Branched from Single-phase, Three-wire Circuit

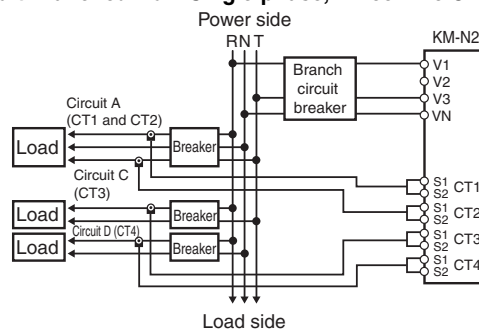

Three-phase, Three-wire Circuit

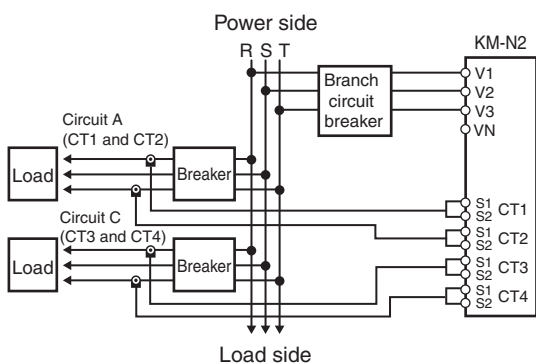

Single-phase, Two-wire Circuit

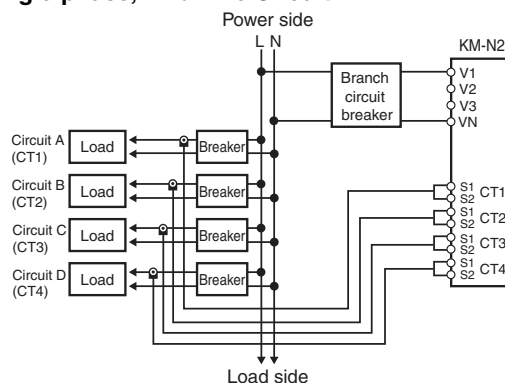

CT Wiring

- For each circuit, one CT is required to measure single-phase two-wire power, two CTs are required to measure single-phase three-wire power or three-phase three-wire power, and three CTs are required to measure three-phase four-wire power.
- Use AWG18 to AWG14 (cross-sectional area: 0.75 to 2.0 mm²) wires with a heat resistance of 85°C min. to connect to the CT input terminals.
- Use ferrules suitable for the wire diameter to connect to the CT input terminals.
- The recommended tightening torque for M3 terminal screws is 0.5 to 0.6 N·m. Push ferrules all the way in and tighten the screws securely.

Voltage Wiring (Power supply voltage and measurement voltage are shared.)

- The Power Monitor has voltage input terminals V1, V2, V3, and VN, which function as both the operating power supply terminals and voltage measurement terminals.
- Connect a branch circuit breaker between the voltage input terminals and the wiring so that the power supply can be turned OFF immediately.
- For safety, always work with the power supply turned OFF both at the main power supply and at the branch circuit breaker.
- Connect the wires in the correct phase sequence. Otherwise, the power and power consumption cannot be measured correctly.
- When wiring the power supply and measured voltage terminals, use round or forked crimp terminals (6.7 mm wide or less) suitable for M3.5 screws and AWG24 to AWG14 (cross-sectional area: 0.2 to 2.0 mm²) wires.
- Recommended tightening torque for M3.5 terminal screws: 0.8 N·m. Push crimp terminals all the way in and tighten the screws securely. After securing the wiring, gently pull on the cables to check that they are held securely.
- Always use the Power Monitor with the terminal covers closed.

KM-N2-FLK

Wiring Diagram

The following table shows the relationship between the wire phases connected to the voltage input terminals and CT input terminals for each phase wiring method.

	Phase wires connected to voltage input terminals				Phase wires connected to CT input terminals				Number of measured circuits
	V1	V2	V3	VN	CT1	CT2	CT3	CT4	
Single-phase, 2-wire	Phase L (VR)	---	---	Phase N (VN)	Phase L 1	Phase L 2	Phase L 3	Phase L 4	4
Single-phase, 3-wire	Phase R (VR)	---	Phase T (VT)	Phase N (VN)	Phase R 1	Phase T 1	Phase R 2	Phase T 2	2
Three-phase, 3-wire	Phase R (VR)	Phase S (VS)	Phase T (VT)	---	Phase R 1	Phase T 1	Phase R 2	Phase T 2	2
Three-phase, 4-wire	Phase R (VR)	Phase S (VS)	Phase T (VT)	Phase N (VN)	Phase R	Phase S	Phase T	---	1

Note: The numbers in "phase L 1" and "phase L 2" indicate the number of the circuit.

RS-485 Communications Wiring Diagram

- The connection configuration is 1:1 or 1:N. For a 1:N configuration, up to 99 nodes can be connected for Modbus and up to 31 nodes can be connected for CompoWay. If you measure more than one circuit with one Power Monitor, the number of circuits is treated as the number of connected Power Monitors.
- The terminal block has push-in terminals. When wiring, observe the Precautions for Correct Use in *Wires and Precautions for Using Push-in Plus Terminal Blocks (RS-485 Communications Terminals and Pulse Output Terminals)*.
- The KM-N2 does not have a FG terminal. Connect only the positive and negative lines for RS-485.
- Use twisted-pair cables.
- Wire the RS-485 communications lines and power lines separately to prevent the influences of noise.
- The maximum transmission distance is 1,200 m.
- Always test communications on the actual system regardless of the transmission distances and number of connected Power Monitors.
- Always close the terminal block covers before you use the Power Monitor.

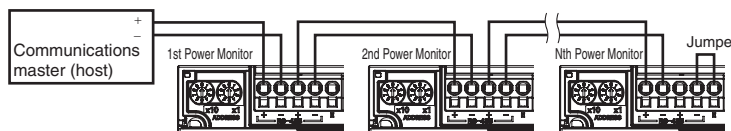

Communications Address Setting

Turn the rotary switches for the 1s and 10s positions and set the communications address for circuit A.

- The value on the rotary switches is assigned as the communications address for circuit A (1st circuit). When multiple addresses are used, the values given in the following table are allocated automatically.
- The communications addresses for circuit B through circuit D cannot be set individually.

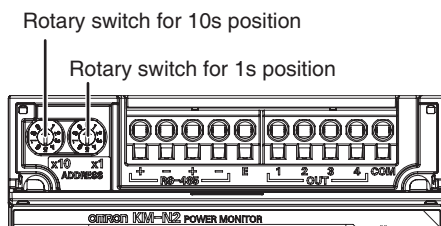

	Circuit A	Circuit B	Circuit C	Circuit D
Three-phase, four-wire	Set value	---	---	---
Single-phase, two-wire circuit branched from single-phase, two-wire circuit or single-phase, three-wire circuit	Set value	Set value +1	Set value +2	Set value +3
Single-phase, three-wire circuit or three-phase, three-wire circuit	Set value	---	Set value +1	---
Single-phase, three-wire circuit and single-phase, two-wire circuit branched from single-phase, three-wire circuit	Set value	---	Set value +1	Set value +2

Terminating Resistance Setting

- The Power Monitor has terminating resistance built in. On the last node on the communications line, connect a jumper between the RS-485 negative terminal and the RS-485 E terminal. The internal terminating resistance will be connected.
- When using a host that does not have built-in terminating resistance, connect terminating resistance to the host as well. The terminating resistance is 120 Ω (1/2 W).
- Do not wire terminating resistance to the KM-N2 partway along the transmission path. Communications failures may occur.

Pulse Output Wiring Diagrams

NPN Output Connection Diagram

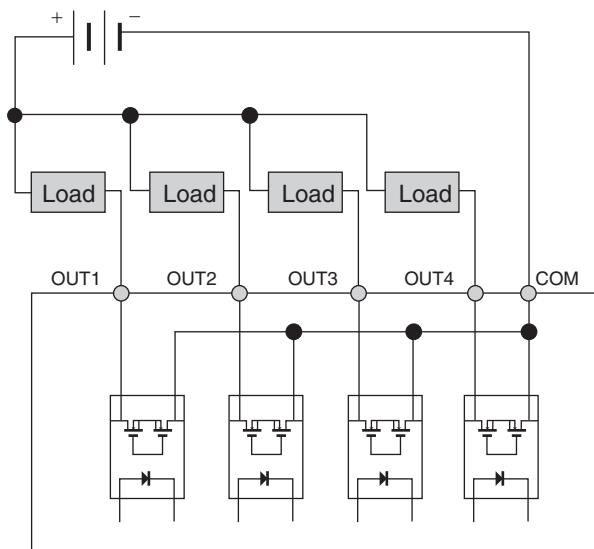

PNP Output Connection Diagram

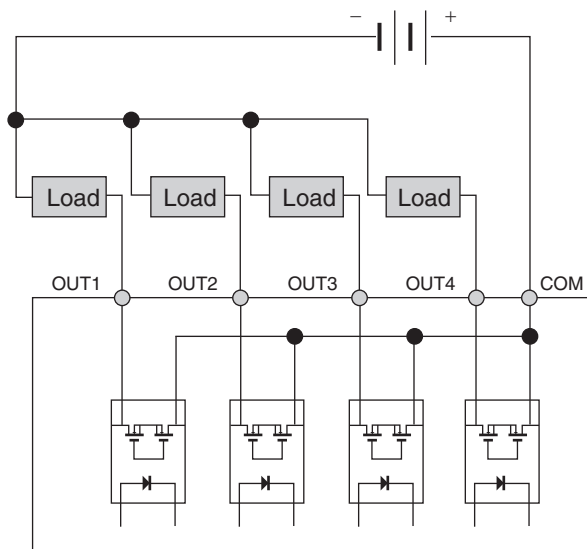

The Power Monitor provides four pulse output terminals. One common is used.

- The terminal block has push-in terminals. When wiring, observe the Precautions for Correct Use in *Wires and Precautions for Using Push-in Plus Terminal Blocks (RS-485 Communications Terminals and Pulse Output Terminals)*.
- Never connect an external power supply directly between an output terminal and the common. Always connect a load.
- Wire signal lines and power lines separately to prevent the influences of noise.
- The outputs are assigned as follows and cannot be changed: OUT1 is for circuit A, OUT2 is for circuit B, OUT3 is for circuit C, and OUT4 is for circuit D.

Dimensions

(Unit: mm)

Power Monitor

KM-N2-FLK

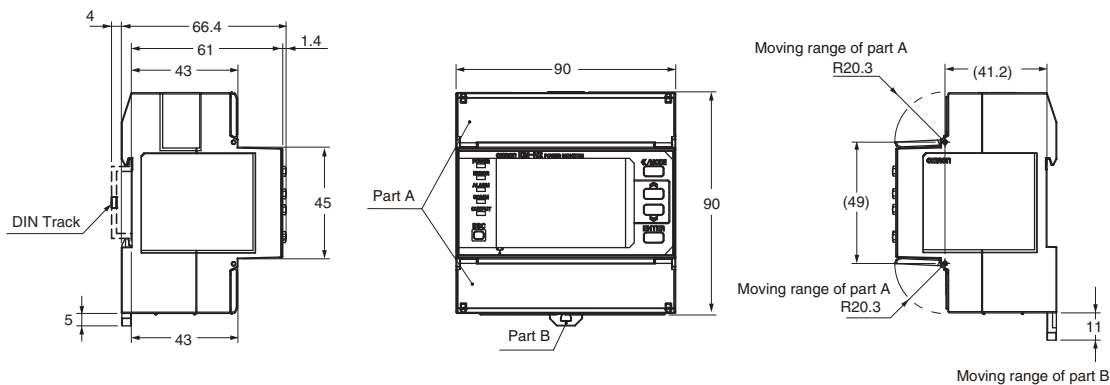

KM-NCT-E100A
KM-NCT-E250A
KM-NCT-E500A
 (CE marking compliant
 KM-N2/N3 dedicated
 products *)

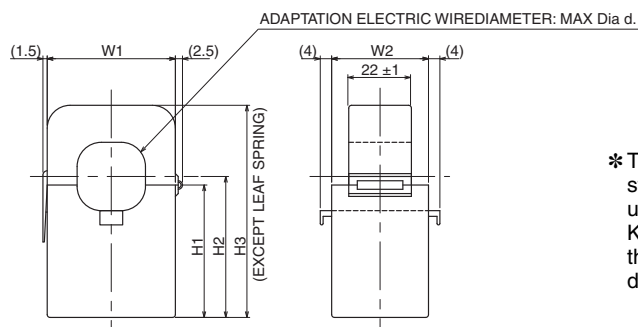

* The KM-NCT-E conforms to the standards shown above ONLY when it is used with a power monitor KM-N2-FLK or KM-N3-FLK to which it is attached. Use of the KM-NCT-E without a power monitor does not conform to these standards.

Dimension (mm)	Dia. d	W1	W2	H1	H2	H3
KM-NCT-E100A	24	45 ± 2	34 ± 2	46.5 ± 1	49.5 ± 1	74.5 ± 1
KM-NCT-E250A	24	45 ± 2	34 ± 2	46.5 ± 1	49.5 ± 1	74.5 ± 1
KM-NCT-E500A	36	57 ± 2	40.5 ± 2	56.5 ± 1	61 ± 1.5	91 ± 2

Power Monitor KM-N3-FLK

Global Power Monitor for On-panel Installation



- Solve design, installation, and operation topics.
- You can measure up to four circuits with one Power Monitor.
- Use general-purpose CTs and handle a variety of worksites.
- Large, easy-to-read white and green LCD for improved visibility.
- IEC Class 0.5S high-precision measurements (Power Monitor only).



NEW

For the most recent information on models that have been certified for safety standards, refer to your OMRON website.

⚠ Refer to Safety Precautions on page 19.

Ordering Information

Power Monitor

Model	Applicable phase wiring methods	Power supply voltage	Dimensions	Communications
KM-N3-FLK	Single-phase, 2-wire: 100 to 277 VAC Single-phase, 3-wire: 100 to 240 VAC (L-N) or 200 to 480 VAC (L-L) Three-phase, 3-wire: 173 to 480 VAC (L-L) Three-phase, 4-wire: 100 to 277 VAC (L-N) or 173 to 480 VAC (L-L)	100 to 240 VAC Separate from measurement voltage.	96 × 96 × 64 mm (H×W×D) (excluding protrusions)	RS-485 communications, pulse output

To use a commercially available current transformer, use a CT with a secondary current rating of 1 A or 5 A, and a rated load of at least 1.0 VA.

Optional Products (Order Separately)

Terminal Covers

Model
E53-COV24 (3pcs)

Mounting Adapter

Model
Y92F-51 (2pcs)

Note: This Mounting Adapter is provided with the KM-N3.

Waterproof Packing

Model
Y92S-P10

Note: This Waterproof Packing is provided with the KM-N3.

Split Type Current Transformer (CT) (CE marking compliant KM-N2/N3 dedicated products *)

Model	Rated primary current	Rated secondary current
KM-NCT-E100A	100 A	1 A
KM-NCT-E250A	250 A	
KM-NCT-E500A	500 A	

* The KM-NCT-E conforms to the standards shown above ONLY when it is used with a power monitor KM-N2-FLK or KM-N3-FLK to which it is attached. Use of the KM-NCT-E without a power monitor does not conform to these standards.

Note: Select a CT cable that does not exceed the rated load of 1 VA.

Specifications

Ratings (Power Monitor)

Item	Model	KM-N3-FLK
Applicable phase wiring methods		Single-phase two-wire, single-phase three-wire, three-phase three-wire, and three-phase four-wire
Number of measured circuits		Single-phase two-wire: 4 circuits max., Single-phase three-wire or three-phase three-wire: 2 circuits max., Three-phase four-wire: 1 circuit
Power supply voltage (operating frequency)		100 to 240 VAC (50/60 Hz)
Power supply allowable voltage range		85% to 110% of rated power supply voltage
Power consumption		7 VA max.
Input	Rated input voltages	Single-phase, 2-wire: 100 to 277 VAC Single-phase, 3-wire: 100 to 240 VAC (L-N) or 200 to 480 VAC (L-L) Three-phase, 3-wire: 173 to 480 VAC (L-L) Three-phase, 4-wire: 100 to 277 VAC (L-N) or 173 to 480 VAC (L-L)
	Allowable supply voltage range	85% to 115% of rated power supply voltage
	Connectable CTs	General-purpose CT with a rated secondary current of 1 A or 5 A *
	Maximum CT secondary current	6 A
	Rated input frequency	50/60 Hz
Ambient operating temperature		-25 to 55°C (with no condensation or icing)
Ambient operating humidity		25% to 85%
Storage temperature		-25 to 85°C (with no condensation or icing)
Storage humidity		25% to 85%
Operating altitude		2,000 m max.
Installation environment		Overvoltage category II, measurement category II, pollution degree 2
Electromagnetic environment		Industrial electromagnetic environment (EN/IEC 61326-1 Table 2)
Compliant standards		EN 61010-2-030, EN 61326-1, and UL 61010-1

* The KM-series CTs (the KM20-CTF or KM-NCT Series) cannot be used. Use general-purpose CTs with a secondary-side output of 1 A or 5 A.

Split Type Current Transformer (CT) (CE marking compliant KM-N2/N3 dedicated products *)

Item	KM-NCT-E100A	KM-NCT-E250A	KM-NCT-E500A
Rated primary current: In	100 A	250 A	500 A
Rated secondary current: Is	1 A		
Rated frequency	50/60 Hz		
Cable Length	Please refer to <i>Writing to KM-NCT-E□□□A</i>		
Rated load	1 VA		
Insulation resistance	100 MΩ min. (at 500 VDC mega) between core and all output terminals		
Dielectric strength voltage	2300 VAC, 1 minute between core and all output terminals.		
Weight	Approx. 170 g	Approx. 175 g	Approx. 290 g
Maximum wire diameter	24 dia.	24 dia.	36 dia.
Operating temperature and humidity range	-20 to 55 °C, relative humidity: 85% max. with no condensation		
Storage temperature and humidity range	-30 to 90 °C, relative humidity: 85% max. with no condensation		
Applicable standards *	EN61010-1, EN61010-2-030, EN61326-1		
Installation environment	Overvoltage category and measurement category: II, Pollution level: 2		

* The KM-NCT-E conforms to the standards shown above ONLY when it is used with a power monitor KM-N2-FLK or KM-N3-FLK to which it is attached. Use of the KM-NCT-E without a power monitor does not conform to these standards.

Wiring to KM-NCT-E□□□A

- For wiring of the output terminal of CT, use AWG18-14 electric wire (with a cross-section of 0.75-2.0mm²) and Y-shape terminal compatible with the M3 screw.
- The recommended torque for screwing the M3 screws onto the output terminal is 0.3 N·m. Make sure the Y terminal is pushed all the way in and tightened firmly. After fixing the wiring, confirm that the wire is fixed securely.
- The guideline of the maximum wiring length between KM-N2-FLK or KM-N3-FLK and KM-NCT-E is as follows.
The longer the wire length, the larger the measurement error using the KM-NCT-E becomes.
- The limit of the wiring length can also be calculated by the following formula. Calculate the wiring length limit according to the conductor resistivity of the wiring and keep the wiring length below the limit.
- The limits of the wiring length shown below are for reference only. They do not guarantee proper use.

Wiring diameter	Guideline for wiring length limit
0.75 mm ² (AWG18 equivalent)	15 m
2.0 mm ² (AWG14 equivalent)	43 m

$$\text{Wiring extension limit value (one-way) (m)} = \frac{0.475}{\text{conductor resistivity } (\Omega/\text{m})}$$

Note: Select a CT cable that does not exceed the rated load of 1 VA.

KM-N3-FLK

Performance (Power Monitor)

Item	Model	KM-N3-FLK
Measured items		Total power consumption (active, regenerative, and reactive), power (active and reactive), current, voltage, power factor, and frequency
Measurement specifications	Active power	0.5% (IEC 62053-22 class 0.5S *)
	Reactive power	2% (IEC 62053-23 class 2) *
	Sampling cycle	80 ms for 50 Hz and 66.7 ms for 60 Hz
Insulation resistance		(1) Between all electrical circuits and the case: 20 MΩ min. (at 500 VDC) (2) Between all power supply and voltage inputs and all communications and pulse output terminals: 20 MΩ max. (at 500 VDC)
Dielectric strength		(1) Between all electrical circuits and the case: 1,400 VAC for 1 min (2) Between all voltage and current inputs and all communications and pulse output terminals: 1,400 VAC for 1 min
Vibration resistance		Single amplitude: 0.1 mm, Acceleration: 15 m/s ² , Frequency: 10 to 150 Hz, 10 sweeps for 8 min each along three axes
Shock resistance		150 m/s ² , 3 times each in 6 directions (up/down, left/right, forward/backward)
Indications and operation method		LCD indications and operation buttons
Weight		Approx. 350 g (Power Monitor only)
Degree of protection		Front: IP65, Rear case: IP20, Terminal: IP00
Pulse output	Number of outputs	Number of outputs: 4 (photoMOS relay outputs) Used for the total power consumption pulse output.
	Output capacity	50 mA at 40 VDC ON residual voltage: 1.5 V max. (for output current of 50 mA) OFF leakage current: 0.1 mA max.
	Output unit	Output unit: 1, 10, 100, 1k, 5k, 10k, 50k, or 100k (wh) Pulse ON time: 500 ms (Cannot be changed.)
Communications interface	Communications method	RS-485 (2-wire half-duplex with start-stop synchronization)
	Communications protocol	Modbus (RTU): Binary. CompoWay/F: ASCII
	Baud rate	1.2, 2.4, 4.8, 9.6, 19.2, or 38.4 kbps
	Data length	Data length: 7 or 8 bits Stop bits: 1 or 2 bits Vertical parity: Even, odd, or none
	Maximum transmission distance	1,200 m
	Maximum number of connected Power Monitors	Modbus: 99, CompoWay/F: 31 If you measure more than one circuit with one Power Monitor, the number of circuits is treated as the number of connected Power Monitors.
Dimensions (HxWxD)		96 × 96 × 64 mm (excluding protrusions)
Installation method		On-panel installation
Accessories		Instruction Manual and Compliance Sheet, Mounting adapter and waterproof packing

* The error of the CT or VT is not included. IEC 62053 is an international standard for power metering.

Part Names and Functions

Power Monitor

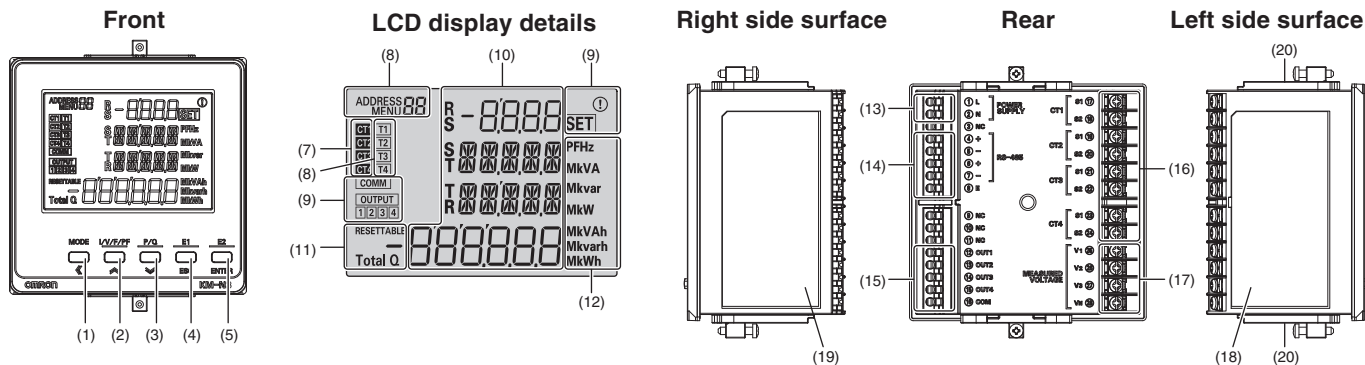

No.	Item	Description
(1)	MODE ◀ key	Long press: The measurement mode is switched with the setup mode. [MODE] key (measurement mode): The measurement circuit is changed. [◀] key (setup mode): Change of the measurement circuit / Digit shifting when a numerical value is input
(2)	I/V/F/PF ▶ key	[I/V/F/PF] key (measurement mode): The display of current, voltage, frequency, or power factor is switched. [▶] key (setup mode): Items or values are changed (up)
(3)	P/Q ⇄ key	[P/Q] key (measurement mode): The display of effective power or reactive power is switched. [⇄] key (setup mode): Items or values are changed (down)
(4)	E1•ESC key	[ESC] key (measurement mode): Cancel [E1] key (setup mode): The display of each integrated electric energy is switched.

No.	Item	Description	
(5)	E2•ENTER key	[ENTER] key (measurement mode): Select/Determine [E2] key (setup mode): The display of each resettable integrated electric energy is switched.	
(6)	Communication address / Menu display	When ADDRESS is lit (in the measurement mode): The communication address is displayed. When MENU is lit (in the setup mode): The menu number is displayed.	
(7)	In-operation CT display	The CT number in the condition of measurement or setup (CT1 to CT4) is displayed.	
(8)	Tariff display	The tariff number which is saving the integrated effective energy (T1 to T4) is displayed.	
(9)	State display	COMM	Blinks when RS-485 communications are in progress.
		OUTPUT	Lit when the pulse output is set.
		1	Lit when pulse is output from OUT 1.
		2	Lit when pulse is output from OUT 2.
		3	Lit when pulse is output from OUT 3.
		4	Lit when pulse is output from OUT 4.
		SET	Lit in the setup mode.
①	Blinks when a warning occurs.		
(10)	Measured value display / Setup value display	First display / instantaneous value display	Instantaneous values or setup values are displayed (on rows No. 1-3).
		Second display / Integrated value display	The integrated value is displayed (on row No. 4).
(11)	Measurement auxiliary display	RESETTABLE	Lit when resettable integrated electric energy is displayed.
		---	Lit when integrated leading reactive electric energy is displayed.
		Total Q	Lit when total integrated reactive electric energy is displayed.
(12)	Unit display	The unit of each measured value is lit.	
(13)	Power supply terminal	Power supply voltage is input to this terminal	
(14)	RS-485 communication terminal	RS-485 + (1)	RS-485 + terminal
		RS-485 - (1)	RS-485 - terminal
		RS-485 + (2)	RS-485 + terminal (for transition wiring)
		RS-485 - (2)	RS-485 - terminal (for transition wiring)
		RS-485E	RS-485 terminating resistor terminal
(15)	Pulse output terminal	OUT1	Circuit A pulse output terminal
		OUT2	Circuit B pulse output terminal
		OUT3	Circuit C pulse output terminal
		OUT4	Circuit D pulse output terminal
		COM	Common terminal for outputting pulse
(16)	CT input terminal	Terminal to connect the CT cable for CT1 to CT4	
(17)	Measured voltage input terminal	Measured voltage is input to this terminal.	
(18)	Terminal array label	Model, power supply voltage, terminal array, serial number, and so on are written on this label.	
(19)	Wiring label	A wiring diagram of voltage and current is written on this label.	
(20)	Mounting adapter	Adapter to fix the main unit to the panel	

Connection Wiring Diagrams

Three-phase, Four-wire Circuit

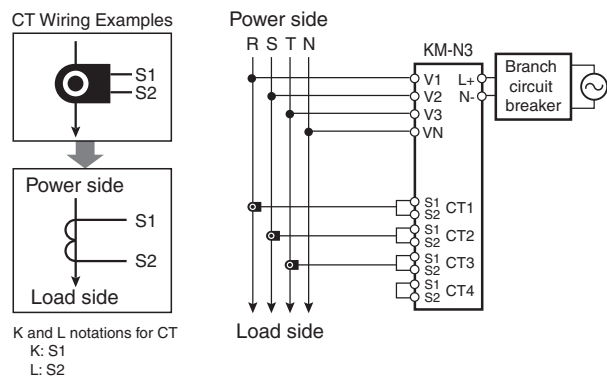

Single-phase, Two-wire Circuit Branched from Single-phase, Three-wire Circuit

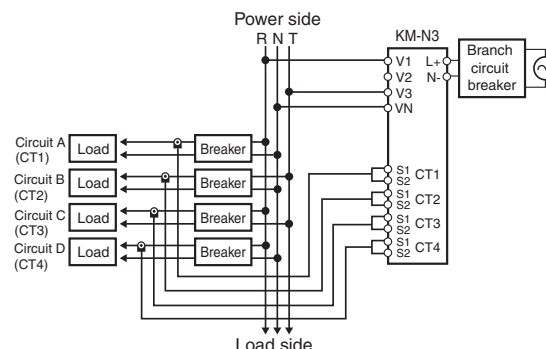

KM-N3-FLK

Single-phase, Three-wire Circuit

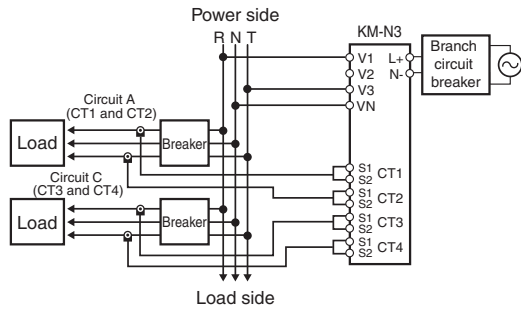

Single-phase, Three-wire Circuit and Single-phase, Two-wire Circuit Branched from Single-phase, Three-wire Circuit

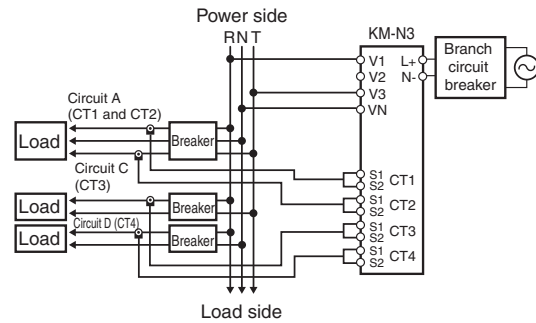

Three-phase, Three-wire Circuit

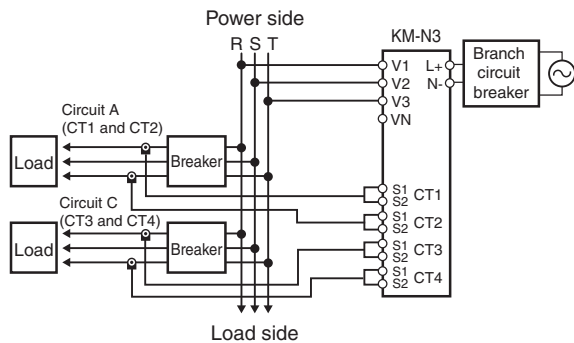

Single-phase, Two-wire Circuit

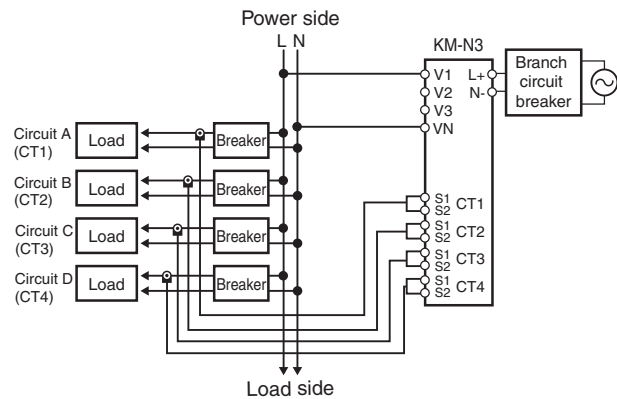

CT Wiring

- For each circuit, one CT is required to measure single-phase two-wire power, two CTs are required to measure single-phase three-wire power or three-phase three-wire power, and three CTs are required to measure three-phase four-wire power.
- Use AWG18 to AWG14 (cross-sectional area: 0.75 to 2.0 mm²) wires and round or forked crimp terminals (5.8 mm wide or less) suitable for M3 screws to connect to the CT input terminals.
- The recommended tightening torque for M3 terminal screws is 0.5 to 0.58 N·m. Push crimp terminals all the way in and tighten the screws securely. After you secure the wires, confirm that they are securely held in place.

Power Supply Wiring

- Connect a branch circuit breaker between the power supply terminal and the wiring so that the power supply can be turned OFF immediately.
- For safety, always work with the power supply turned OFF both at the main power supply and at the branch circuit breaker.
- The terminal block has push-in terminals. When wiring, observe the Precautions for Correct Use in *Wires and Precautions for Using Push-in Plus Terminal Blocks (RS-485 Communications Terminals and Pulse Output Terminals)*.

Wiring Measurement Voltages

- For safety, always work with the power supply turned OFF both at the main power supply.
- Connect the wires in the correct phase sequence. Otherwise, the power and power consumption cannot be measured correctly.
- When wiring the measured voltage terminals, use round or forked crimp terminals (5.8 mm wide or less) suitable for M3 screws and AWG18 to AWG14 (cross-sectional area: 0.75 to 2.0 mm²) wires.
- Recommended tightening torque for M3 terminal screws: 0.5 to 0.58 N·m. Push crimp terminals all the way in and tighten the screws securely. After securing the wiring, gently pull on the cables to check that they are held securely.

Wiring Diagram

The following table shows the relationship between the wire phases connected to the voltage input terminals and CT input terminals for each phase wiring method.

	Phase wires connected to voltage input terminals				Phase wires connected to CT input terminals				Number of measured circuits
	V1	V2	V3	VN	CT1	CT2	CT3	CT4	
Single-phase, 2-wire	Phase L (VR)	---	---	Phase N (VN)	Phase L 1	Phase L 2	Phase L 3	Phase L 4	4
Single-phase, 3-wire	Phase R (VR)	---	Phase T (VT)	Phase N (VN)	Phase R 1	Phase T 1	Phase R 2	Phase T 2	2
Three-phase, 3-wire	Phase R (VR)	Phase S (VS)	Phase T (VT)	---	Phase R 1	Phase T 1	Phase R 2	Phase T 2	2
Three-phase, 4-wire	Phase R (VR)	Phase S (VS)	Phase T (VT)	Phase N (VN)	Phase R	Phase S	Phase T	---	1

Note: The numbers in "phase L 1" and "phase L 2" indicate the number of the circuit.

RS-485 Communications Wiring Diagram

- The connection configuration is 1:1 or 1:N. For a 1:N configuration, up to 99 nodes can be connected for Modbus and up to 31 nodes can be connected for CompoWay. If you measure more than one circuit with one Power Monitor, the number of circuits is treated as the number of connected Power Monitors.
- The terminal block has push-in terminals. When wiring, observe the Precautions for Correct Use in *Wires and Precautions for Using Push-in Plus Terminal Blocks (RS-485 Communications Terminals and Pulse Output Terminals)*.

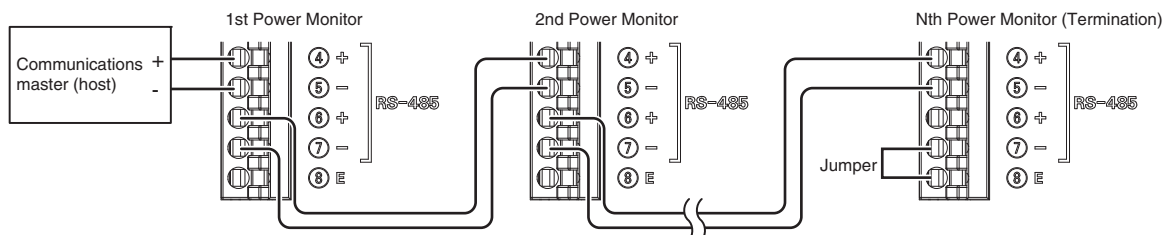

- The KM-N3 does not have a FG terminal. Connect only the positive and negative lines for RS-485.
- Use twisted-pair cables.
- Wire the RS-485 communications lines and power lines separately to prevent the influences of noise.
- The maximum transmission distance is 1,200 m.
- Always test communications on the actual system regardless of the transmission distances and number of connected Power Monitors.

Communications Address Setting

- Change to Setting Mode and set the communications address for circuit A. Refer to the Instruction Manual for the communications address setting method. If the multi-address function is used, the addresses in the following table are automatically allocated based on the communications address set for circuit A (the first circuit).
- The communications addresses for circuit B through circuit D cannot be set individually.

	Circuit A	Circuit B	Circuit C	Circuit D
Three-phase, four-wire	Set value	---	---	---
Single-phase, two-wire circuit branched from single-phase, two-wire circuit or single-phase, three-wire circuit	Set value	Set value +1	Set value +2	Set value +3
Single-phase, three-wire circuit or three-phase, three-wire circuit	Set value	---	Set value +1	---
Single-phase, three-wire circuit and single-phase, two-wire circuit branched from single-phase, three-wire circuit	Set value	---	Set value +1	Set value +2

Terminating Resistance Setting

- The Power Monitor has terminating resistance built in. On the last node on the communications line, connect a jumper between the RS-485 negative terminal and the RS-485 E terminal. The internal terminating resistance will be connected.
- When using a host that does not have built-in terminating resistance, connect terminating resistance to the host as well. The terminating resistance is 120 Ω (1/2 W).
- Do not wire terminating resistance to the KM-N3 partway along the transmission path. Communications failures may occur.

Pulse Output Wiring Diagrams

NPN Output Connection Diagram

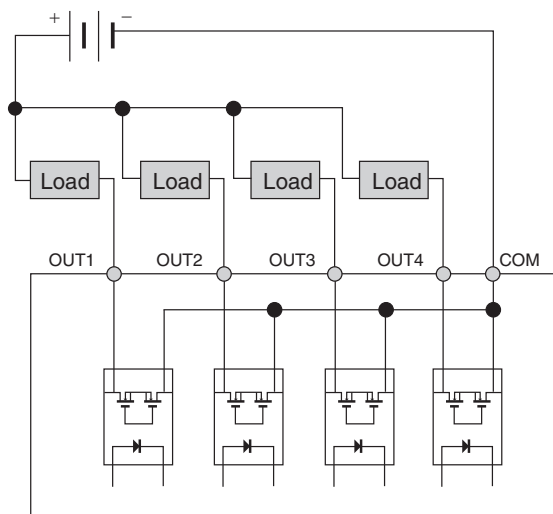

PNP Output Connection Diagram

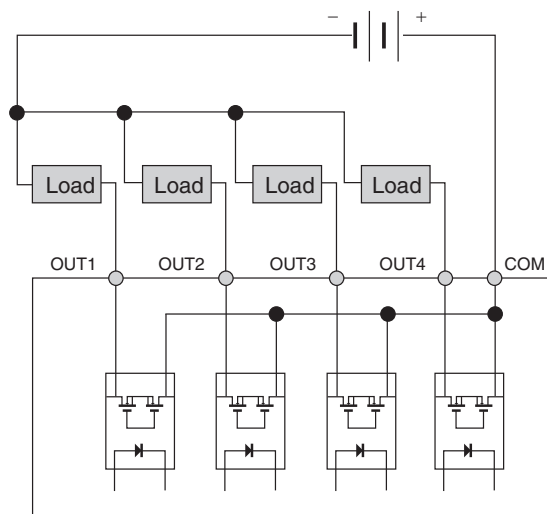

The Power Monitor provides four pulse output terminals. One common is used.

- The terminal block has push-in terminals. When wiring, observe the Precautions for Correct Use in *Wires and Precautions for Using Push-in Plus Terminal Blocks (RS-485 Communications Terminals and Pulse Output Terminals)*.
- Never connect an external power supply directly between an output terminal and the common. Always connect a load.
- Wire signal lines and power lines separately to prevent the influences of noise.
- The outputs are assigned as follows and cannot be changed: OUT1 is for circuit A, OUT2 is for circuit B, OUT3 is for circuit C, and OUT4 is for circuit D.

KM-N3-FLK

Dimensions

(Unit: mm)

Power Monitor

KM-N3-FLK

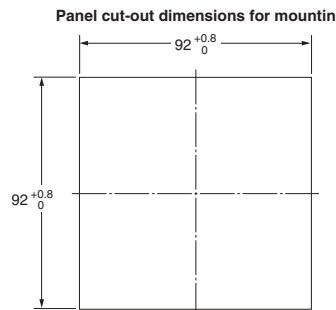
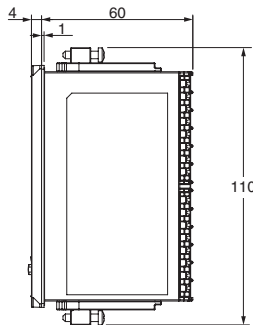
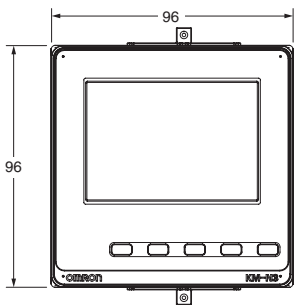
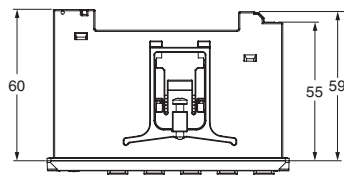

KM-NCT-E100A
KM-NCT-E250A
KM-NCT-E500A
 (CE marking compliant
 KM-N2/N3 dedicated
 products *)

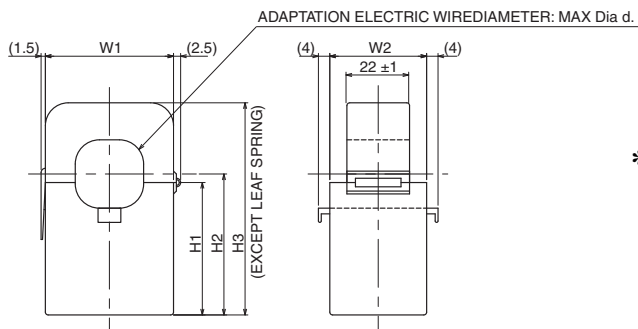

* The KM-NCT-E conforms to the standards shown above ONLY when it is used with a power monitor KM-N2-FLK or KM-N3-FLK to which it is attached. Use of the KM-NCT-E without a power monitor does not conform to these standards.

Dimension (mm)	Dia. d	W1	W2	H1	H2	H3
KM-NCT-E100A	24	45 ±2	34 ±2	46.5 ±1	49.5 ±1	74.5 ±1
KM-NCT-E250A	24	45 ±2	34 ±2	46.5 ±1	49.5 ±1	74.5 ±1
KM-NCT-E500A	36	57 ±2	40.5 ±2	56.5 ±1	61 ±1.5	91 ±2

Optional Products (Order Separately)

Terminal Covers

E53-COV24 (Three Covers provided.)

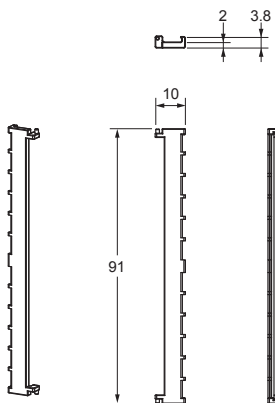

Waterproof Packing

Y92S-P10 (for DIN 96 × 96)

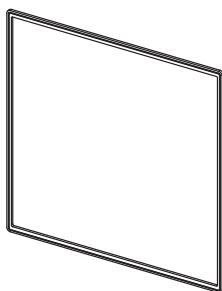

The Waterproof Packing is provided with the KM-N3. Order the Waterproof Packing separately if it becomes lost or damaged. The Waterproof Packing for the front-panel Setup Tool port must be periodically replaced because they may deteriorate, shrink, or harden depending on the operating environment. The replacement period will vary with the operating environment. Check the required period in the actual application. Use 3 years or sooner as a guideline.

Mounting Adapter

Y92F-51 (Two Adapters provided.)

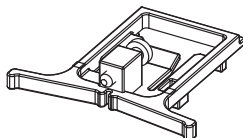

One pair is provided with the KM-N3. Order this Adapter separately if it becomes lost or damaged.

Safety Precautions

Warning Indications

	CAUTION	Indicates a potentially hazardous situation which, if not avoided, may result in minor or moderate injury or in property damage.
---	----------------	--

Caution

Property damage may occasionally occur due to fire. Tighten terminal screws to the specified tightening torque.

Confirm that there is no looseness in the screws after tightening them.

M3.5 screws: 0.8 N·m

M3 screws: 0.5 to 0.6 N·m (KM-N2),
0.5 to 0.58 N·m (KM-N3)



Minor or moderate bodily harm or property damage may occasionally occur due to explosion.

Do not use the Power Monitor near inflammable or explosive gas.



Destruction or rupture may occasionally occur.

Make sure that the power supply voltages and loads are within specifications and ratings.



Electrical shock may occasionally occur.

Do not touch any of the terminals while the power is being supplied.



Electric shock may occasionally occur.

Always turn OFF the power supply to the circuit where a CT is mounted before you connect the CT terminals on the Power Monitor.



Electrical shock, minor injury, fire, or equipment malfunction may occasionally occur.

Do not apply a current that exceeds the maximum current for the CT secondary side to the CT input terminals.



Electrical shock, minor injury, fire, or equipment malfunction may occasionally occur.

Do not disassemble, repair, or modify the Power Monitor.



* CT: Current transformer

	Meaning of Warning Symbols Electric shock may occasionally occur. Use wires with a heat resistance of 85°C min. to connect to the voltage input, CT input, and communications terminals.
---	---

Precautions for Safe Use

Observe the following precautions to ensure the safe usage of the KM-N2/N3.

- Do not store, install, or use the Power Monitor in the following locations.
 - Locations that are greatly affected by vibration or shock
 - Unstable locations
 - Locations where the specified range of temperature or humidity would be exceeded
 - Locations that are subject to rapid changes in temperature or humidity where condensation or icing may occur
 - Outdoors or locations that are subject to direct sunlight, wind, or rain
 - Locations that are affected by static electricity or noise
 - Locations that are affected by electric or magnetic fields
 - Locations that are subject to flooding or oil
 - Locations that are subject to splashing brine
 - Locations that are subject to corrosive gas (particularly sulfide or ammonia gas)
 - Locations that are excessively dusty or dirty
 - Locations with miscible liquids
- Be sure to wire properly with the terminals with correct symbols.
- Please use stranded or solid wires with the specified cross section for wiring of the terminals.
 - KM-N2 voltage input terminal:
AWG24 to AWG14 (cross-sectional area: 0.2 to 2.0 mm²)
 - KM-N2 or N3 CT input terminal:
AWG18 to AWG14 (cross-sectional area: 0.75 to 2.0 mm²)
 - KM-N3 power supply terminal:
AWG20 to AWG16 (cross-sectional area: 0.5 to 1.5 mm²)
 - KM-N3 measured voltage input terminal:
AWG18 to AWG14 (cross-sectional area: 0.75 to 2.0 mm²)
- Be sure to check that the wiring is correct before turning on the power.
- Before using or maintaining the product, thoroughly read and understand this manual.
- Understand the user manuals when you set the Power Monitor.
- Do not pull on the cables.
- Do not use any application methods that are not given in the operation manual. Protection implemented in the equipment could be lost.
- Install and suitably label a switch or circuit breaker that is appropriate for the voltage that is being used and complies with the relevant standards for your country so that the operator can immediately turn OFF the power supply. (USA: Use a UL-listed switch or circuit breaker, Canada: Use a cUL-listed switch or circuit breaker, Other countries: Use a branch circuit breaker that complies with IEC 60947-1 and IEC 60947-3 or with other relevant standards.)
We recommend that you use a branch circuit breaker with a rated current of 1 A.
- Always check the wiring and confirm that it is correct before turning ON the power supply. Incorrect or improper wiring may result in electrical shock, injury, accidents, failure, or malfunction.
- Do not touch any of the terminals while the power is being supplied.
- Do not install the Power Monitors near sources of heat, such as devices with coils or windings.
- When you install the DIN Tracks, make sure that the screws are tightened securely. Mount the Power Monitor securely to the DIN Track. If the Power Monitor is loose, vibration or shock can cause the DIN Track, Power Monitor, or wires to become disconnected (for the KM-N2).
- Use DIN Tracks with a width of 35 mm (OMRON PFP-50N/-100N) (for the KM-N2).
- If you mount the Power Monitor on DIN Track, slide the DIN hook until it securely and audibly locks in place (for the KM-N2).
- To prevent inductive noise, wire the lines connected to the Power Monitor separately from power lines carrying high voltages or currents. Do not wire in parallel with or in the same cable as power lines. Other measures for reducing noise include running lines in separate ducts and using twisted-pair cables.

KM-N2-FLK/KM-N3-FLK

- The Power Monitor is a Class A product (for use in industrial environments). In residential environment areas, it may cause radio interference. If it causes radio interference, the user may be required to take adequate measures to reduce interference.
- Install the product in a panel with a panel thickness of 1 to 8 mm. If a suitable panel thickness is not used or the product is installed incorrectly, the product may come free from the mounting (for the KM-N3).

Precautions for Correct Use

- This Power Monitor is not a Special Measuring Instrument that has passed testing by a specified body under the Measurement Act of Japan. It cannot be used to certify power consumption under Japanese law.
- Make sure that all settings are set suitably for the measurement targets.
- When using the Power Monitor in an Overvoltage Category III environment, externally install varistors between the power supply and voltage measurement inputs to the Power Monitor.
- Do not use the Power Monitor for measurement on the secondary side of an inverter.
- Make sure the rated voltage is reached within 2 seconds after the power is turned ON.
- Always turn OFF all power before cleaning the Power Monitor. Dry wipe the surfaces of the Power Monitor with a soft, dry cloth. Never use any chemical that contains solvents such as paint thinner, benzene, or alcohol.
- OMRON's KM-series CTs (e.g., the KM20-CTF or KM-NCT Series) cannot be used. Use CTs with a secondary-side output of 1 A or 5 A.
- To comply with standards, always use ferrules when you connect to the input terminals on CTs (for the KM-N2).
- The total power consumption and other data is saved every 5 minutes. When the power supply to the Power Monitor is turned OFF, the last 5 minutes worth of data may not have been saved.
- When discarding the Power Meter, properly dispose of it as industrial waste according to all applicable local ordinances.

Mounting to and Removing

Mounting to and Removing from DIN Track (KM-N2)

- **Mounting a Unit**
Pull down the DIN Track hook on the Terminal Unit and catch the top hook on the DIN Track.
Press the Unit onto the DIN Track until the DIN Track hooks are locked in place.

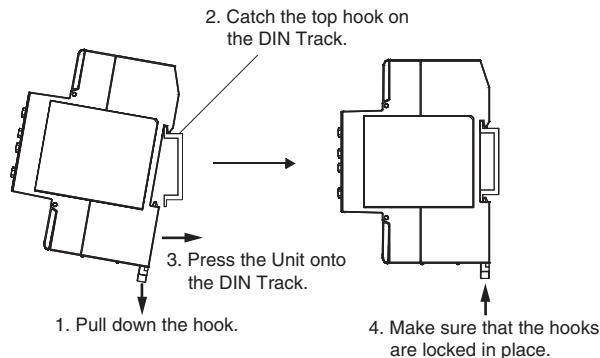

- **Removing a Unit**
Pull down on the DIN Track Hook with a flat-blade screwdriver and lift up the Unit.

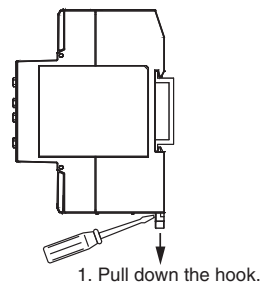

Mounting to a Panel (KM-N3)

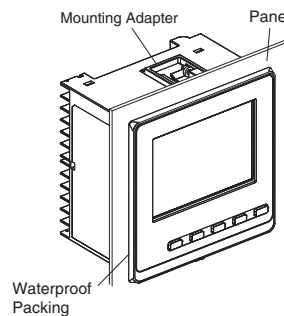

1. In order to make the unit waterproof, with the accessory waterproof packing on the front of the panel, insert the unit into the panel opening.
Unless the waterproof packing is put, the product is not waterproof.
2. Fit the attached mounting adapter into the fixing grooves on the top and bottom faces of the rear case.
3. Push in the mounting adapter from the terminal side until it contacts the panel to fix the main unit tentatively.
4. Fasten the fixing screws of the top and bottom mounting adapter alternately as keeping balance little by little.
Apply a fastening torque of 0.29 to 0.39 N·m.

Mounting the Terminal Cover

Slightly bend the E53-COV24 Terminal Cover to attach it to the terminal block as shown in the following diagram. The Terminal Cover cannot be attached in the opposite direction.

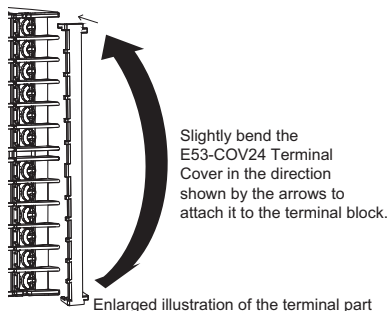

Wires and Precautions for Using Push-in Plus Terminal Blocks (RS-485 Communications Terminals and Pulse Output Terminals)

1. Applicable Wires

- For the KM-N3 power supply wiring, use AWG20 to AWG16 (cross-sectional area: 0.5 to 1.5 mm²) stranded or solid wires.
- Wire used for RS-485 communication terminal and Pulse output terminal. Use stranded or solid wires of AWG24 to AWG16 (cross-sectional area: 0.25 to 1.5 mm²).
- Strip the wires for 10 mm if you use ferrules and for 8 mm if you do not use ferrules.

2. Connecting Wires to the Push-In Plus Terminal Block Part Names of the Terminal Block

When connecting Push-in Plus Terminal Blocks (RS-485 communications terminals and pulse output terminals), use the following procedure.

KM-N2

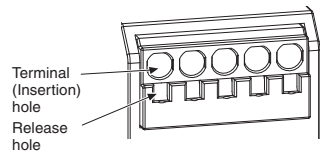

KM-N3

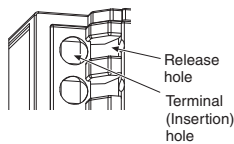

Connecting Wires with Ferrules and Solid Wires

Insert the solid wire or ferrule straight into the terminal block until the end strikes the terminal block.

- If a wire is difficult to connect because it is too thin, use a flat-blade screwdriver in the same way as when connecting stranded wire.

KM-N2

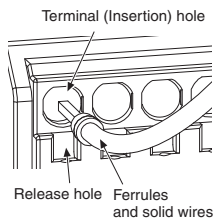

KM-N3

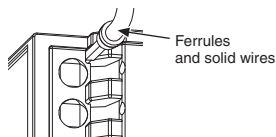

Connecting Stranded Wires

Use the following procedure to connect the wires to the terminal block.

1. Hold a flat-blade screwdriver at an angle and insert it into the release hole.
The angle is the diagram below. If the flat-blade screwdriver is inserted correctly, you will feel the spring in the release hole.
2. With the flat-blade screwdriver still inserted into the release hole, insert the wire into the terminal hole until it strikes the terminal block.
3. Remove the flat-blade screwdriver from the release hole.

KM-N2

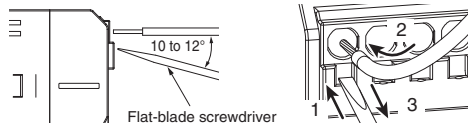

KM-N3

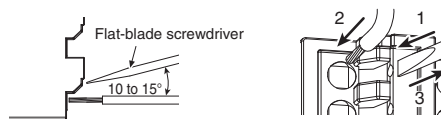

Checking Connections

- After the insertion, pull gently on the wire to make sure that it will not come off and the wire is securely fastened to the terminal block.
- To prevent short circuits, insert the stripped part of a stranded or solid wire or the conductor part of a ferrule until it is hidden inside the terminal insertion hole. (See the following diagram.)

KM-N2

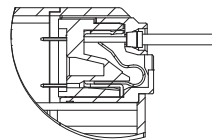

KM-N3

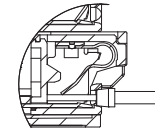

3. Removing Wires from the Push-In Plus Terminal Block

Use the following procedure to remove wires from the terminal block. The same method is used to remove stranded wires, solid wires, and ferrules.

1. Hold a flat-blade screwdriver at an angle and insert it into the release hole.
2. With the flat-blade screwdriver still inserted into the release hole, remove the wire from the terminal insertion hole.
3. Remove the flat-blade screwdriver from the release hole.

KM-N2

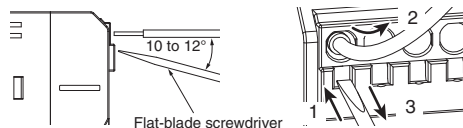

KM-N3

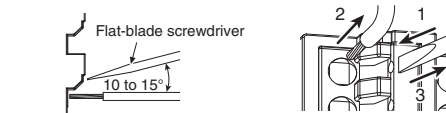

KM-N2-FLK/KM-N3-FLK

4. Recommended Ferrules and Crimp Tools

Recommended ferrules

Applicable wire		Ferrule Conductor length (mm)	Stripping length (mm) (Ferrules used)	Recommended ferrules		
(mm ²)	(AWG)			Phoenix Contact product	Weidmuller product	Wago product
0.25 *1	24	8	10	AI 0,25-8	H0.25/12	216-301
		10	12	AI 0,25-10	---	---
0.34 *1	22	8	10	AI 0,34-8	H0.34/12	216-302
		10	12	AI 0,34-10	---	---
0.5	20	8	10	AI 0,5-8	H0.5/14	216-201
		10	12	AI 0,5-10	H0.5/16	216-241
0.75	18	8	10	AI 0,75-8	H0.75/14	216-202
		10	12	AI 0,75-10	H0.75/16	216-242
1/1.25	18/17	8	10	AI 1-8	H1.0/14	216-203
		10	12	AI 1-10	H1.0/16	216-243
1.25/1.5 *2	17/16	8	10	AI 1,5-8	H1.5/14	216-204
		10	12	AI 1,5-10	H1.5/16	216-244
Recommended crimp tool				CRIMPFOX6 CRIMPFOX6-F CRIMPFOX10S	PZ6 roto	Variocrimp4

- Note:**
1. Make sure that the outer diameter of the wire coating is smaller than the inner diameter of the insulation sleeve of the recommended ferrule.
 2. Make sure that the ferrule processing dimensions conform to the following figures.

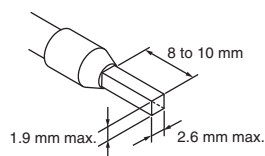

- *1. If you use AWG24 to AWG22 (0.25 to 0.34 mm²) wires, UL certification will not apply.
- *2. Do not connect ferrules for the applicable wires (AWG17 to AWG16 (1.25 to 1.5 mm²) to adjacent terminal (insertion) holes.

Recommended Flat-blade Screwdriver

Use a flat-blade screwdriver to connect and remove wires.

Use the following flat-blade screwdriver.

The following table shows manufacturers and models as of 2015/Dec.

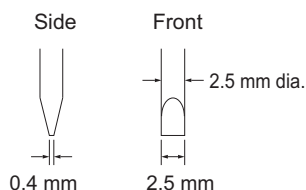

Model	Manufacturer
ESD0.40 × 2.5	Wera
SZF 0.4 × 2.5 SZF 0-0.4 × 2.5 *	Phoenix Contact
0.4 × 2.5 × 75 302	Wiha
AEF.2.5 × 75	Facom
210-719	Wago
SDI 0.4 × 2.5 × 75	Weidmuller

* SZF 0-0.4 × 2.5 (Phoenix Contact) is can be arranged from Omron XW4Z-00B.

Terms and Conditions Agreement

Read and understand this catalog.

Please read and understand this catalog before purchasing the products. Please consult your OMRON representative if you have any questions or comments.

Warranties.

- (a) Exclusive Warranty. Omron's exclusive warranty is that the Products will be free from defects in materials and workmanship for a period of twelve months from the date of sale by Omron (or such other period expressed in writing by Omron). Omron disclaims all other warranties, express or implied.
- (b) Limitations. OMRON MAKES NO WARRANTY OR REPRESENTATION, EXPRESS OR IMPLIED, ABOUT NON-INFRINGEMENT, MERCHANTABILITY OR FITNESS FOR A PARTICULAR PURPOSE OF THE PRODUCTS. BUYER ACKNOWLEDGES THAT IT ALONE HAS DETERMINED THAT THE PRODUCTS WILL SUITABLY MEET THE REQUIREMENTS OF THEIR INTENDED USE.

Omron further disclaims all warranties and responsibility of any type for claims or expenses based on infringement by the Products or otherwise of any intellectual property right. (c) Buyer Remedy. Omron's sole obligation hereunder shall be, at Omron's election, to (i) replace (in the form originally shipped with Buyer responsible for labor charges for removal or replacement thereof) the non-complying Product, (ii) repair the non-complying Product, or (iii) repay or credit Buyer an amount equal to the purchase price of the non-complying Product; provided that in no event shall Omron be responsible for warranty, repair, indemnity or any other claims or expenses regarding the Products unless Omron's analysis confirms that the Products were properly handled, stored, installed and maintained and not subject to contamination, abuse, misuse or inappropriate modification. Return of any Products by Buyer must be approved in writing by Omron before shipment. Omron Companies shall not be liable for the suitability or unsuitability or the results from the use of Products in combination with any electrical or electronic components, circuits, system assemblies or any other materials or substances or environments. Any advice, recommendations or information given orally or in writing, are not to be construed as an amendment or addition to the above warranty.

See <http://www.omron.com/global/> or contact your Omron representative for published information.

Limitation on Liability; Etc.

OMRON COMPANIES SHALL NOT BE LIABLE FOR SPECIAL, INDIRECT, INCIDENTAL, OR CONSEQUENTIAL DAMAGES, LOSS OF PROFITS OR PRODUCTION OR COMMERCIAL LOSS IN ANY WAY CONNECTED WITH THE PRODUCTS, WHETHER SUCH CLAIM IS BASED IN CONTRACT, WARRANTY, NEGLIGENCE OR STRICT LIABILITY.

Further, in no event shall liability of Omron Companies exceed the individual price of the Product on which liability is asserted.

Suitability of Use.

Omron Companies shall not be responsible for conformity with any standards, codes or regulations which apply to the combination of the Product in the Buyer's application or use of the Product. At Buyer's request, Omron will provide applicable third party certification documents identifying ratings and limitations of use which apply to the Product. This information by itself is not sufficient for a complete determination of the suitability of the Product in combination with the end product, machine, system, or other application or use. Buyer shall be solely responsible for determining appropriateness of the particular Product with respect to Buyer's application, product or system. Buyer shall take application responsibility in all cases.

NEVER USE THE PRODUCT FOR AN APPLICATION INVOLVING SERIOUS RISK TO LIFE OR PROPERTY OR IN LARGE QUANTITIES WITHOUT ENSURING THAT THE SYSTEM AS A WHOLE HAS BEEN DESIGNED TO ADDRESS THE RISKS, AND THAT THE OMRON PRODUCT(S) IS PROPERLY RATED AND INSTALLED FOR THE INTENDED USE WITHIN THE OVERALL EQUIPMENT OR SYSTEM.

Programmable Products.

Omron Companies shall not be responsible for the user's programming of a programmable Product, or any consequence thereof.

Performance Data.

Data presented in Omron Company websites, catalogs and other materials is provided as a guide for the user in determining suitability and does not constitute a warranty. It may represent the result of Omron's test conditions, and the user must correlate it to actual application requirements. Actual performance is subject to the Omron's Warranty and Limitations of Liability.

Change in Specifications.

Product specifications and accessories may be changed at any time based on improvements and other reasons. It is our practice to change part numbers when published ratings or features are changed, or when significant construction changes are made. However, some specifications of the Product may be changed without any notice. When in doubt, special part numbers may be assigned to fix or establish key specifications for your application. Please consult with your Omron's representative at any time to confirm actual specifications of purchased Product.

Errors and Omissions.

Information presented by Omron Companies has been checked and is believed to be accurate; however, no responsibility is assumed for clerical, typographical or proofreading errors or omissions.

Products That Create New Value in Control Panels



Switch Mode Power Supplies
S8VK-S



Uninterruptible Power Supply (UPS)
S8BA



Power Monitors
KM-N2/KM-N3



Measuring and Monitoring Relays
K8DT



Solid-state Timers
H3DT



Solid-state Timers
H3Y(N)-B



Solid-state Timers
H3RN-B



Liquid Leakage Sensor Amplifiers
K7L-B



Sockets for Relays with Forcibly Guided Contacts (for G7SA)
P7SA-PU



Common Sockets (for MY/H3Y(N)-B)
PYF-PU(-L)



Common Sockets (for G2R-S/H3RN-B/K7L-B)
P2RF-PU



Slim I/O Relays
G2RV-SR



Slim I/O Relays
G3RV-SR



I/O Relay Terminals
G70V



Pushbutton Switches Push-in Plus Terminal Block Series
A22N-P/A30N-P/M22N-P



Solid State Relays for Heaters
G3PJ



DIN Track Terminal Block
XW5T



Digital Temperature Controllers
E5CC-B/E5EC-B

Panel Assist Web

www.ia.omron.com/solution/panel/



Innovation in Control Panel Building
Cat. No. Y218

OMRON Corporation Industrial Automation Company
Tokyo, JAPAN

Contact: www.ia.omron.com

Regional Headquarters

OMRON EUROPE B.V.
Wegalaan 67-69-2132 JD Hoofddorp
The Netherlands
Tel: (31)2356-81-300/Fax: (31)2356-81-388

OMRON ASIA PACIFIC PTE. LTD.

No. 438A Alexandra Road # 05-05/08 (Lobby 2),
Alexandra Technopark,
Singapore 119967
Tel: (65) 6835-3011/Fax: (65) 6835-2711

OMRON ELECTRONICS LLC
2895 Greenspoint Parkway, Suite 200
Hoffman Estates, IL60169 USA
Tel: (1) 847-843-7900/Fax: (1) 847-843-7787

OMRON (CHINA) CO., LTD.
Room 2211, Bank of China Tower,
200 Yin Cheng Zhong Road,
PuDong New Area, Shanghai, 200120, China
Tel: (86) 21-5037-2222/Fax: (86) 21-5037-2200

Authorized Distributor:

© OMRON Corporation 2016-2018 All Rights Reserved.
In the interest of product improvement,
specifications are subject to change without notice.

CSM_3_8_0419
Cat. No. N213-E1-05

0818(0316)



SCATTERGOOD & JOHNSON LTD

ELECTRICAL ENGINEERING & FLUID CONTROL DISTRIBUTORS

Est.1899

At Scattergood & Johnson Ltd, we pride ourselves on being a technical distributor to specialist industries.

Working with a range of quality product suppliers across a number of specialist markets, we are not your average 'box shifter' - we are your technical and supply chain partner.

We fully support every product we sell - for free! Our internal team and external sales engineers can answer any product or application question, no matter the complexity.

Backing up this technical ability is a range of 50,000+ products available from stock for nationwide next day delivery (same day if required!), or you can collect what you need from any of our trade counters around the UK.

Select your specialist interest below to learn more about how we can help.

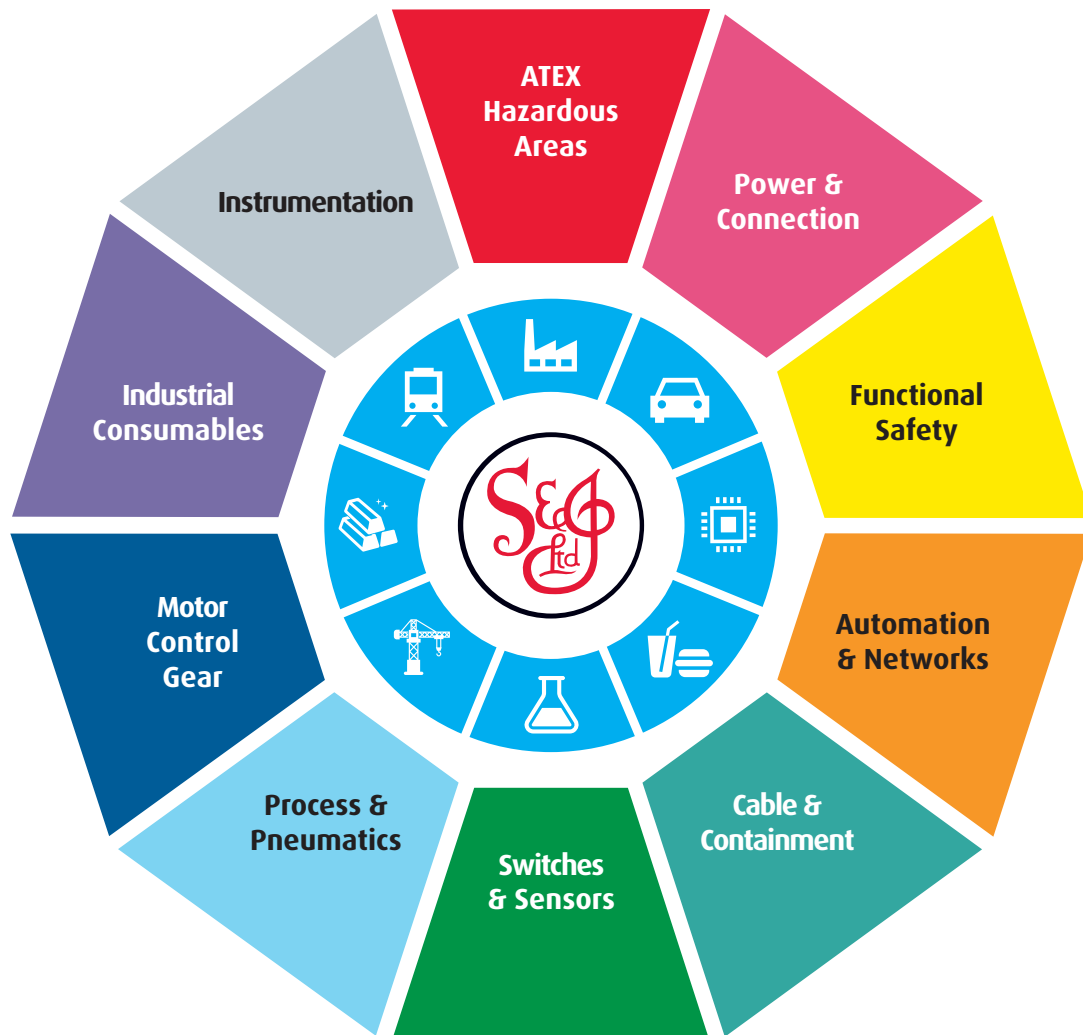

Online, In Branch and On the Road - Scattergood & Johnson Ltd, there when you need us.

www.scatts.co.uk