

NX-series Communications Interface Units

NX-CIF

CSM_NX-CIF_DS_E_8_1

Provides simplicity and flexibility in connecting serial devices to EtherCAT

- Mount to the NX-series EtherCAT Coupler Unit and connect various types of serial devices.
- The serial line monitor on the Sysmac Studio helps easily and reliably connect serial devices.



Features

- Just 12 mm wide, saving space in your cabinet.
- Three models are available with a choice of one RS-422A/485, one RS-232C, or two RS-232C ports.
- Screwless push-in terminal block (1-port model) and D-Sub connector (2-port model) significantly reduce wiring work.
- No-protocol communications are supported as the communications protocol.
- The maximum baud rate is 230.4 kbps. The baud rate can be selected to match the connected serial devices.
- The settings are backed up and saved in the EtherCAT Coupler Unit. This facilitates commissioning and maintenance.
- The serial line monitor enables you to check the communications status with serial devices on the Sysmac Studio for easy and reliable startup of the devices.

System Configuration

System Configuration in the Case of a CPU Unit

The following figure shows a system configuration when a group of NX Units is connected to an NX-series CPU Unit.

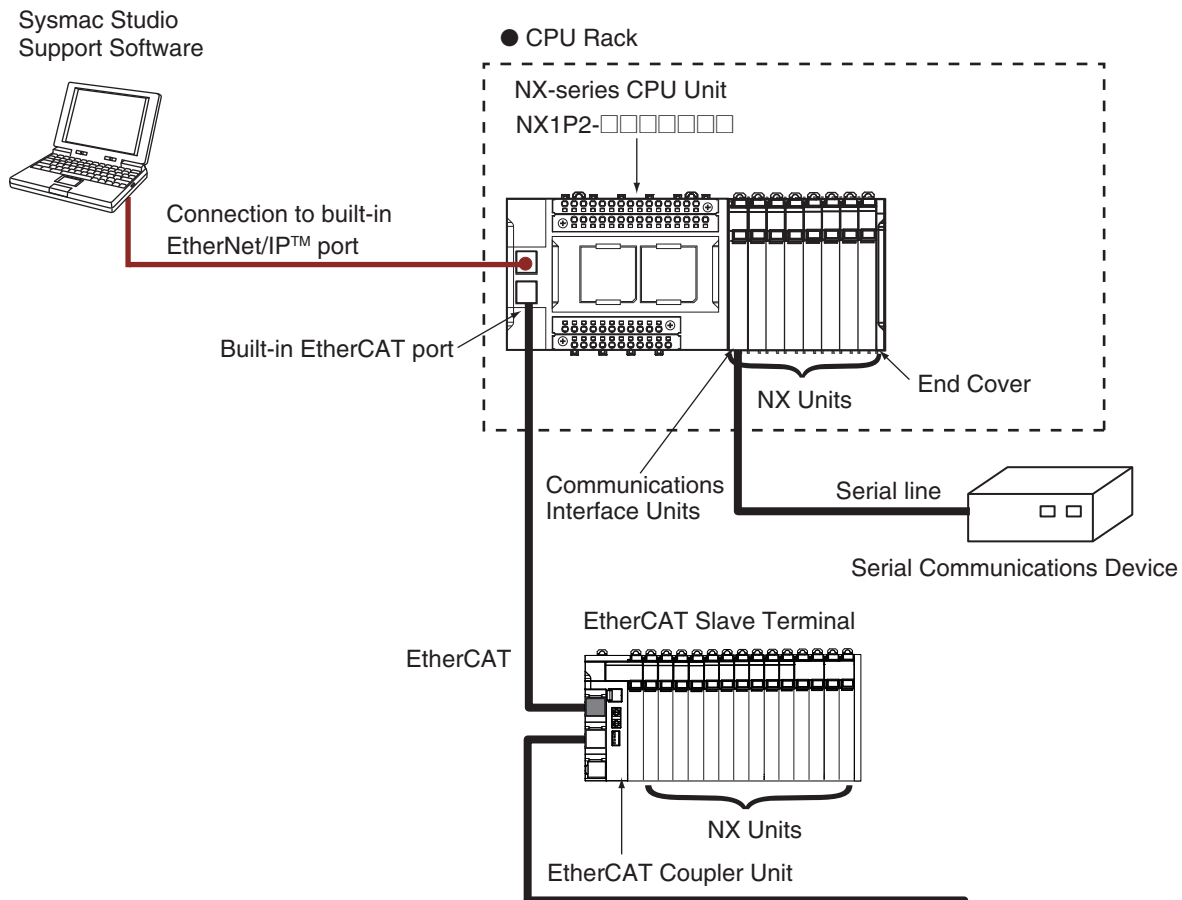

Sysmac is a trademark or registered trademark of OMRON Corporation in Japan and other countries for OMRON factory automation products. EtherCAT® is a registered trademark of Beckhoff Automation GmbH for their patented technology. EtherNet/IP™ is the trademarks of ODVA. Other company names and product names in this document are the trademarks or registered trademarks of their respective companies.

System Configuration of Slave Terminals

The following figure shows an example of the system configuration when an EtherCAT Coupler Unit is used as a Communications Coupler Unit.

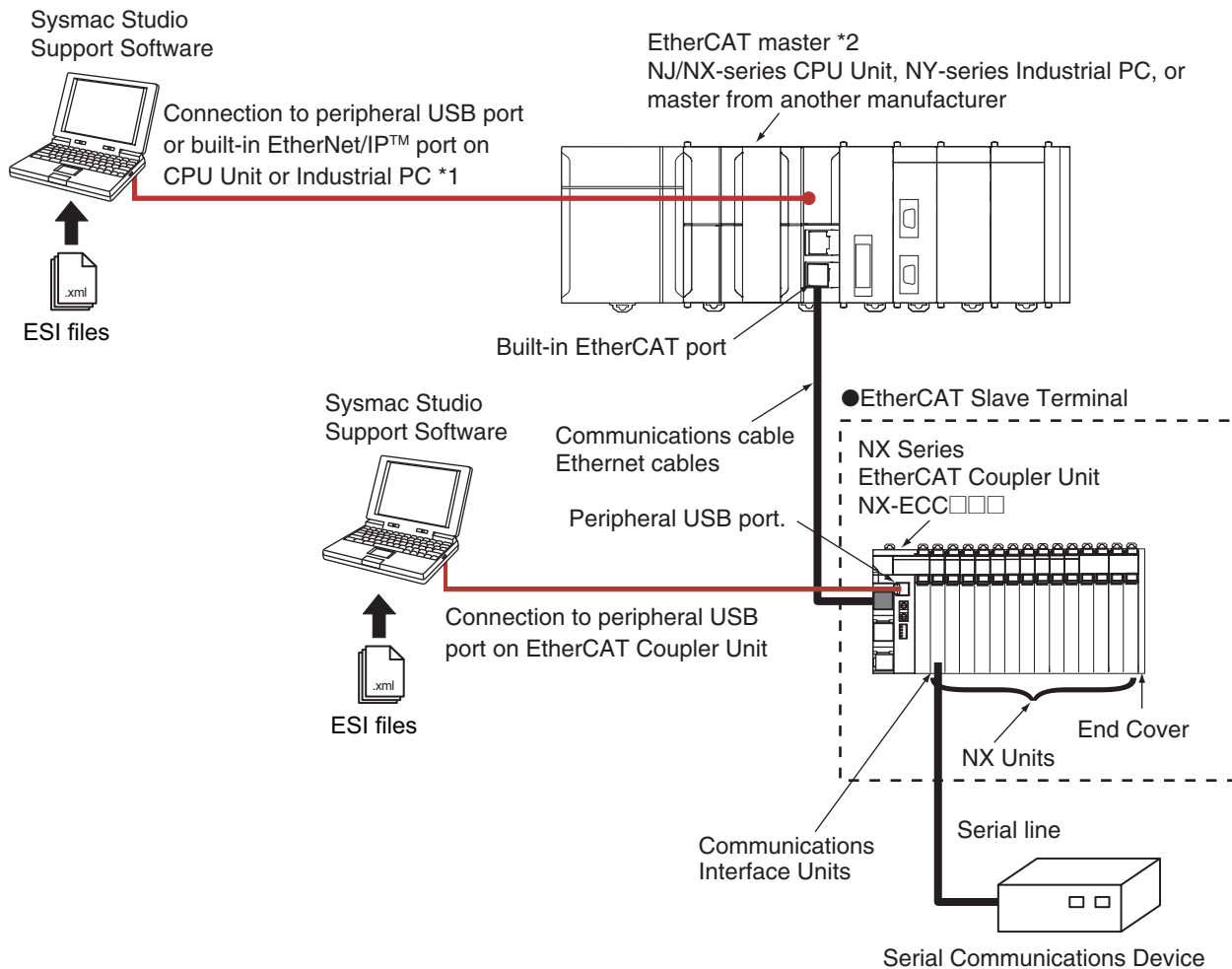

*1. The connection method for the Sysmac Studio depends on the model of the CPU Unit or Industrial PC.

*2. An EtherCAT Slave Terminal cannot be connected to any of the OMRON CJ1W-NC□81/□82 Position Control Units even though they can operate as EtherCAT masters.

Note: For whether NX Units can be connected to the CPU Unit or Communications Coupler Unit to be used, refer to the version information.

Ordering Information

Applicable standards

Refer to the OMRON website (www.ia.omron.com) or ask your OMRON representative for the most recent applicable standards for each model.

Communications Interface Units

Product name	Serial interface	External connection terminals	Number of serial ports	Communications protocol	Model
	RS-232C	Screwless Clamping Terminal Block	1 port	No-protocol Signal lines	NX-CIF101
	RS-422A/485				NX-CIF105
	RS-232C	D-Sub connector	2 ports		NX-CIF210

Optional Products

Product name	Specification	Model
Unit/Terminal Block Coding Pins	Pins for 10 Units (30 terminal block pins and 30 Unit pins)	NX-AUX02

Product name	Specification				Model
	No. of terminals	Terminal number indications	Ground terminal mark	Terminal current capacity	
Terminal Block *	16	A/B	Present	10 A	NX-TBC162

* These options can be used with the NX-CIF101 and NX-CIF105. (They cannot be used with the NX-CIF210.)

Accessories

Not included.

Serial Line Monitor

On the Sysmac Studio, the monitor data is displayed in the CIF Serial Line Monitor tab page. The configuration of the CIF Serial Line Monitor tab page is shown below. The data values are shown from left to right along a time scale. The left edge is the starting point of the monitor.

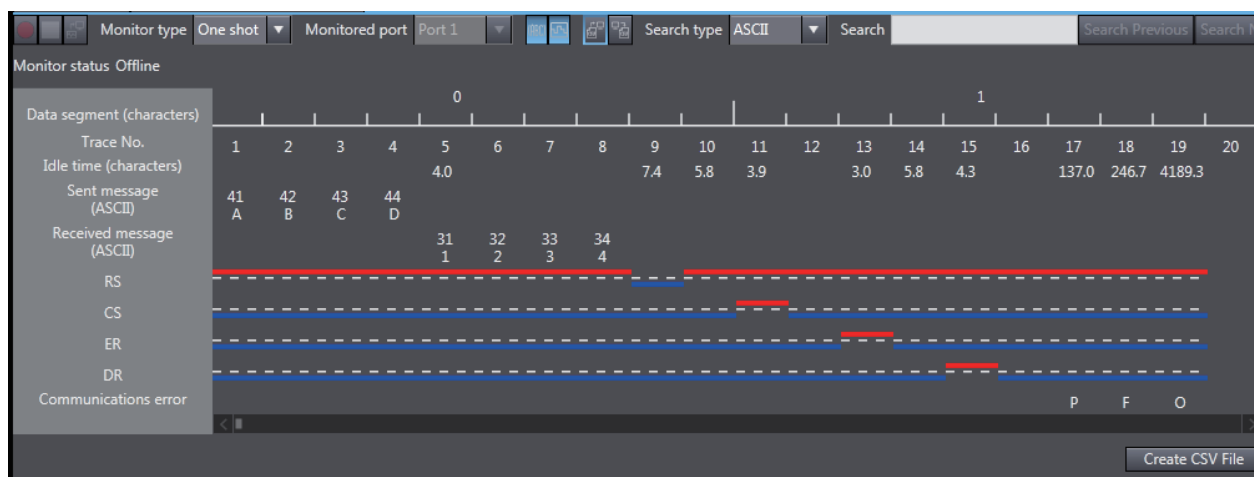

General Specification

Item		Specification
Enclosure		Mounted in a panel.
Grounding method		Ground of 100 Ω or less. If a conductive DIN Track is used, a Communications Interface Units is grounded through the DIN Track from the System Power Supply Unit. If a non-conductive DIN Track is used, a Communications Interface Units is grounded from the FG terminal.
Operating environment	Ambient operating temperature	0 to 55°C
	Ambient operating humidity	10% to 95% (with no condensation or icing)
	Atmosphere	Must be free from corrosive gases.
	Ambient storage temperature	-25 to 70°C (with no condensation or icing)
	Altitude	2,000 m max.
	Pollution degree	2 or less: Meets IEC 61010-2-201.
	Noise immunity	2 kV on power supply line (Conforms to IEC 61000-4-4.)
	Overvoltage category	Category II: Meets IEC 61010-2-201.
	EMC immunity level	Zone B
	Vibration resistance	Conforms to IEC 60068-2-6. 5 to 8.4 Hz with 3.5-mm amplitude, 8.4 to 150 Hz, Acceleration of 9.8 m/s ² , 100 min in X, Y, and Z directions (10 sweeps of 10 min each = 100 min total)
	Shock resistance	Conforms to IEC 60068-2-27. 147 m/s ² , 3 times each in X, Y, and Z directions
	Insulation resistance	20 M Ω min. between isolated circuits (at 100 VDC)
Dielectric strength	510 VAC between isolated circuits for 1 minute with leakage current of 5 mA max.	
Applicable standards *		cULus: Listed (UL508), ANSI/ISA 12.12.01, EU: EN 61131-2, NK, LR, RCM, and KC: KC Registration

* Refer to the OMRON website (<http://www.ia.omron.com/>) or consult your OMRON representative for the most recent applicable standards for each model.

Specifications of Individual Units

NX-CIF101

Item	Specification	
Number of ports	1	
Communications ports	RS-232C	
Communications protocol	No-protocol	
Communications specifications	Communications method	Full duplex
	Signal lines *1	---
	Baud rate [bps] *1	1,200, 2,400, 4,800, 9,600, 19,200, 38,400, 57,600, 115,200, or 230,400
	Data length [bits] *1	7 or 8
	Parity *1	Even, odd, or none
	Start bits [bits]	Always 1.
	Stop bits [bits] *1	1 or 2
	Flow control *1	None, RS/CS flow control, or Xon/Xoff control
	Flow control target *1	Send/receive, send only, or receive only
	Initial RS signal value *1 *2	ON or OFF
	Number of characters to determine the end *1 *3	0 to 10,000 (in increments of 0.1 character) 0: The end is not detected.
	Maximum communications distance [m]	15 *4
	Connection configuration	1:1
I/O refreshing method	Free-Run refreshing only	
PDO data size [bytes] *1	Inputs or outputs: 4, 8, 12, 16, 20, 24, 28, 32, 36, 40, 44, 48, 52, 56, 60, 64, 68, 72, 76, or 80	
Transmission buffering enable/disable setting *1	Enabled or disabled	
Functions to back up data	Provided. *5	
Terminating resistance setting	---	
Isolation method	No isolation	
Power consumption	<ul style="list-style-type: none"> Connected to a CPU Unit 1.10 W max. Connected to a Communications Coupler Unit 0.90 W max. 	
Weight	66 g max.	
Installation orientation and restrictions	Installation orientation: <ul style="list-style-type: none"> Connected to a CPU Unit: Possible in upright installation. Connected to a Communications Coupler Unit: Possible in 6 orientations. Restrictions: There are no restrictions.	

*1. Setting is possible in the Unit operation settings of the Sysmac Studio.

*2. This is the value of the RS signal when the port enters the Operational state or immediately after the port is restarted. The initial value is disabled when RS/CS flow control is set.

*3. This setting is provided for communications protocols that assume the end of the data if data is not received for a specific period of time. For example, if the number of characters to determine the end is set to 35, the end of the data will be assumed if data is not received for the time required to receive 3.5 characters.

*4. If the baud rate is set to higher than 19,200 bps, refer to the manual for the remote communications device.

*5. The settings that are backed up are saved in memory in the Communications Coupler Unit. The settings that are backed up are not saved in the Communications Interface Units.

NX-CIF105

Item	Specification	
Number of ports	1	
Communications ports	RS-422A/485	
Communications protocol	No-protocol	
Communications specifications	Communications method	Half duplex for two-wire connection, Full duplex for four-wire connection
	Signal lines *1	Two lines or four lines
	Baud rate [bps] *1	1,200, 2,400, 4,800, 9,600, 19,200, 38,400, 57,600, 115,200, or 230,400
	Data length [bits] *1	7 or 8
	Parity *1	Even, odd, or none
	Start bits [bits]	Always 1.
	Stop bits [bits] *1	1 or 2
	Flow control *1	None or Xon/Xoff control
	Flow control target *1	Send/receive, send only, or receive only
	Initial RS signal value *1 *2	ON or OFF
	Number of characters to determine the end *1 *3	0 to 10,000 (in increments of 0.1 character) 0: The end is not detected.
	Maximum communications distance [m]	1,200 *4
	Connection configuration	1:N Maximum value of N is 32. You can change between two-wire and four-wire connections.
I/O refreshing method	Free-Run refreshing only	
PDO data size [bytes] *1	Inputs or outputs: 4, 8, 12, 16, 20, 24, 28, 32, 36, 40, 44, 48, 52, 56, 60, 64, 68, 72, 76, or 80	
Transmission buffering enable/disable setting *1	Enabled or disabled	
Functions to back up data	Provided. *5	
Terminating resistance setting	Possible	
Isolation method	Power supply: transformer and photocoupler Signals: Digital isolators	
Power consumption	<ul style="list-style-type: none"> Connected to a CPU Unit 1.65 W max. Connected to a Communications Coupler Unit 1.45 W max. 	
Weight	69 g max.	
Installation orientation and restrictions	Installation orientation: <ul style="list-style-type: none"> Connected to a CPU Unit: Possible in upright installation. Connected to a Communications Coupler Unit: Possible in 6 orientations. Restrictions: There are no restrictions.	

*1. Setting is possible in the Unit operation settings of the Sysmac Studio.

*2. This is the value of the RS signal when the port enters the Operational state or immediately after the port is restarted. The initial value is disabled when RS/CS flow control is set. It is also disabled for the NX-CIF105.

*3. This setting is provided for communications protocols that assume the end of the data if data is not received for a specific period of time. For example, if the number of characters to determine the end is set to 35, the end of the data will be assumed if data is not received for the time required to receive 3.5 characters.

*4. The maximum total cable length for multidrop connections is 1,200 m.

*5. The settings that are backed up are saved in memory in the Communications Coupler Unit. The settings that are backed up are not saved in the Communications Interface Units.

NX-CIF210

Item	Specification	
Number of ports	2	
Communications ports	RS-232C	
Communications protocol	No-protocol	
Communications specifications	Communications method	Full duplex
	Signal lines *1	---
	Baud rate [bps] *1	1,200, 2,400, 4,800, 9,600, 19,200, 38,400, 57,600, 115,200, or 230,400
	Data length [bits] *1	7 or 8
	Parity *1	Even, odd, or none
	Start bits [bits]	Always 1.
	Stop bits [bits] *1	1 or 2
	Flow control *1	None, RS/CS flow control, or Xon/Xoff control
	Flow control target *1	Send/receive, send only, or receive only
	Initial RS signal value *1 *2	ON or OFF
	Number of characters to determine the end *1 *3	0 to 10,000 (in increments of 0.1 character) 0: The end is not detected.
	Maximum communications distance [m]	15 *4
	Connection configuration	1:1
I/O refreshing method	Free-Run refreshing only	
PDO data size [bytes] *1	Inputs or outputs: 4, 8, 12, 16, 20, 24, 28, 32, 36, 40, 44, 48, 52, 56, 60, 64, 68, 72, 76, or 80	
Transmission buffering enable/disable setting *1	Enabled or disabled	
Functions to back up data	Provided. *5	
Terminating resistance setting	---	
Isolation method	No isolation	
Power consumption	<ul style="list-style-type: none"> Connected to a CPU Unit 1.15 W max. Connected to a Communications Coupler Unit 0.95 W max. 	
Weight	91 g max.	
Installation orientation and restrictions	Installation orientation: <ul style="list-style-type: none"> Connected to a CPU Unit: Possible in upright installation. Connected to a Communications Coupler Unit: Possible in 6 orientations. Restrictions: There are no restrictions.	

*1. Setting is possible in the Unit operation settings of the Sysmac Studio.

*2. This is the value of the RS signal when the port enters the Operational state or immediately after the port is restarted. The initial value is disabled when RS/CS flow control is set.

*3. This setting is provided for communications protocols that assume the end of the data if data is not received for a specific period of time. For example, if the number of characters to determine the end is set to 35, the end of the data will be assumed if data is not received for the time required to receive 3.5 characters.

*4. If the baud rate is set to higher than 19,200 bps, refer to the manual for the remote communications device.

*5. The settings that are backed up are saved in memory in the Communications Coupler Unit. The settings that are backed up are not saved in the Communications Interface Units.

Version Information

Connecting with CPU Units

Refer to the user's manual for the CPU Unit for the CPU Unit to which NX Units can be connected.

NX Unit		Corresponding unit versions/versions	
Model	Unit version	CPU Unit	Sysmac Studio
NX-CIF101	Ver.1.0	Ver.1.13	Ver.1.17
NX-CIF105			
NX-CIF210			

Note: Some Units do not have all of the versions given in the table. If a Unit does not have the specified version, support is provided by the oldest available version after the specified version. Refer to the user's manuals for the specific Units for the relation between models and versions.

Connecting with an EtherCAT Coupler Unit

NX Unit		Corresponding unit versions/versions		
Model	Unit version	EtherCAT Coupler Unit	CPU Units or Industrial PCs *	Sysmac Studio
NX-CIF101	Ver.1.0	Ver.1.0	Ver.1.11	Ver.1.15
NX-CIF105				
NX-CIF210				

Note: Some Units do not have all of the versions given in the above table. If a Unit does not have the specified version, support is provided by the oldest available version after the specified version. Refer to the user's manuals for the specific Units for the relation between models and versions.

* The serial communications instructions for the CIF Units are supported by CPU Units with unit version 1.11 or later. If it is not used, it is available for a CPU Unit with unit version 1.10. Refer to the Instructions Reference Manual for the CPU Unit or Industrial PC for the serial communications instructions for the CIF Units.

Connecting with an EtherNet/IP Coupler Unit

NX Unit		Corresponding unit versions/versions					
Model	Unit version	Application with an NJ/NX/NY-series Controller *1			Application with a CS/CJ/CP-series PLC *2		
		EtherNet/IP Coupler Unit *3	CPU Unit or Industrial PC	Sysmac Studio	EtherNet/IP Coupler Unit *3	Sysmac Studio	NX-IO Configurator *4
NX-CIF101	Ver.1.0	Ver.1.2	Ver.1.14	Ver.1.19	Ver.1.2	Ver.1.19	Ver.1.00
NX-CIF105							
NX-CIF210							

Note: Some Units do not have all of the versions given in the above table. If a Unit does not have the specified version, support is provided by the oldest available version after the specified version. Refer to the user's manuals for the specific Units for the relation between models and versions.

- *1 Refer to the user's manual for the EtherNet/IP Coupler Units for information on the unit versions of EtherNet/IP Units that are compatible with EtherNet/IP Coupler Units.
- *2 Refer to the user's manual for the EtherNet/IP Coupler Units for information on the unit versions of CPU Units and EtherNet/IP Units that are compatible with EtherNet/IP Coupler Units.
- *3 Serial communications instructions for CIF Units cannot be used if they are connected to an EtherNet/IP Coupler Unit.
- *4 For connection to an EtherNet/IP Coupler Unit with unit version 1.0, You can connect only to the peripheral USB port on the EtherNet/IP Coupler Unit. You cannot connect with any other path. If you need to connect by another path, use an EtherNet/IP Coupler Unit with unit version 1.2 or later.

External Interface

NX-CIF101/-CIF105

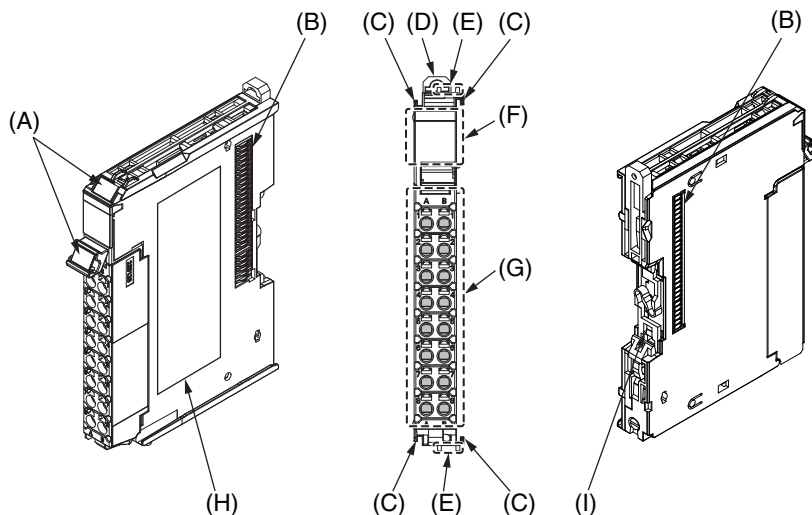

Letter	Name	Description
(A)	Marker attachment location	This is where the markers are attached. OMRON markers are pre-installed at the factory. You can also install commercially available markers.
(B)	NX bus connector	This connector is used to connect each Unit.
(C)	Unit hookup guides	These guides are used to connect two Units.
(D)	DIN Track mounting hooks	These hooks are used to mount the NX Unit to a DIN Track.
(E)	Protrusions for removing the Unit	These protrusions are to hold onto when you need to pull out the Unit.
(F)	Indicators	The indicators show the current operating status of the Unit.
(G)	Terminal block	This terminal block is used to connect the external serial communications device.
(H)	Unit specifications	The specifications of the Unit are given here.
(I)	DIN Track contact plate	This plate is connected internally to the functional ground terminal on the terminalblock.

Terminal Block

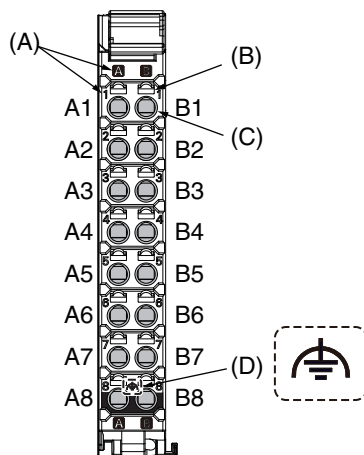

Letter	Name	Description
(A)	Terminal number indication	The terminal numbers are given by column letters A and B, and row numbers 1 to 8. The combination of the column and row gives the terminal numbers from A1 to A8 and B1 to B8.
(B)	Release hole	Insert a flat-blade screwdriver into this hole to connect and remove the wire.
(C)	Terminal hole	The wire is inserted into this hole.
(D)	Ground terminal mark	This mark indicates the ground terminals.

Applicable Terminal Blocks for Each Unit Model

Model	Terminal Blocks				
	Terminal Block	No. of terminals	Terminal number indications	Ground terminal mark	Terminal current capacity
NX-CIF101	NX-TBC162	16	A/B	Present	10 A
NX-CIF105	NX-TBC162	16	A/B	Present	10 A

Applicable Wires

Using Ferrules

If you use ferrules, attach the twisted wires to them.

Observe the application instructions for your ferrules for the wire stripping length when attaching ferrules.

Always use plated one-pin ferrules. Do not use unplated ferrules or two-pin ferrules.

The applicable ferrules, wires, and crimping tool are given in the following table.

Terminal types	Manufacturer	Ferrule model	Applicable wire (mm ² (AWG))	Crimping tool
Terminals other than ground terminals	Phoenix Contact	AI0,34-8	0.34 (#22)	Phoenix Contact (The figure in parentheses is the applicable wire size.) CRIMPFOX 6 (0.25 to 6 mm ² , AWG 24 to 10)
		AI0,5-8	0.5 (#20)	
		AI0,5-10		
		AI0,75-8	0.75 (#18)	
		AI0,75-10		
		AI1,0-8	1.0 (#18)	
		AI1,0-10		
		AI1,5-8	1.5 (#16)	
Ground terminals	Phoenix Contact	AI1,5-10		
		AI2,5-10	2.0 *1	
Terminals other than ground terminals	Weidmuller	H0.14/12	0.14 (#26)	Weidmuller (The figure in parentheses is the applicable wire size.) PZ6 Roto (0.14 to 6 mm ² , AWG 26 to 10)
		H0.25/12	0.25 (#24)	
		H0.34/12	0.34 (#22)	
		H0.5/14	0.5 (#20)	
		H0.5/16		
		H0.75/14	0.75 (#18)	
		H0.75/16		
		H1.0/14	1.0 (#18)	
		H1.0/16		
		H1.5/14	1.5 (#16)	
		H1.5/16		

*1. Some AWG 14 wires exceed 2.0 mm² and cannot be used in the screwless clamping terminal block.

When you use any ferrules other than those in the above table, crimp them to the twisted wires so that the following processed dimensions are achieved.

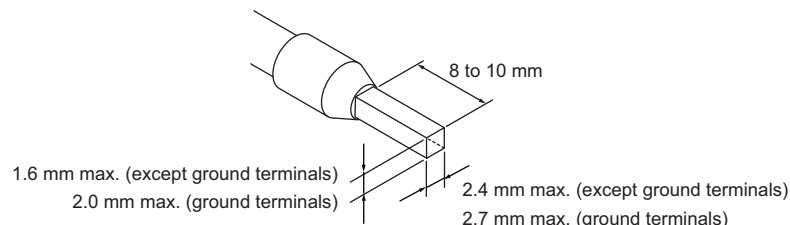

Using Twisted Wires/Solid Wires

If you use the twisted wires or the solid wires, use the following table to determine the correct wire specifications.

Terminals		Wire type				Wire size	Conductor length (stripping length)
		Twisted wires		Solid wire			
Classification	Current capacity	Plated	Unplated	Plated	Unplated		
All terminals except ground terminals	2 A max.	Possible	Possible	Possible	Possible	0.08 to 1.5 mm ² AWG28 to 16	8 to 10 mm
	Greater than 2 A and 4 A or less		Not Possible	Possible *1	Not Possible		
	Greater than 4 A		Possible *1	Not Possible	Not Possible		
Ground terminals	---	Possible	Possible	Possible *2	Possible *2	2.0 mm ²	9 to 10 mm

*1 Secure wires to the screwless clamping terminal block. Refer to the Securing Wires in the USER'S MANUAL for how to secure wires.

*2 With the NX-TB□□□1 Terminal Block, use twisted wires to connect the ground terminal. Do not use a solid wire.

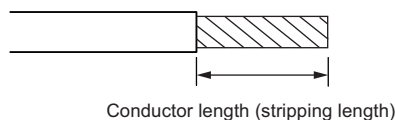

<Additional Information> If more than 2 A will flow on the wires, use plated wires or use ferrules.

NX-CIF210

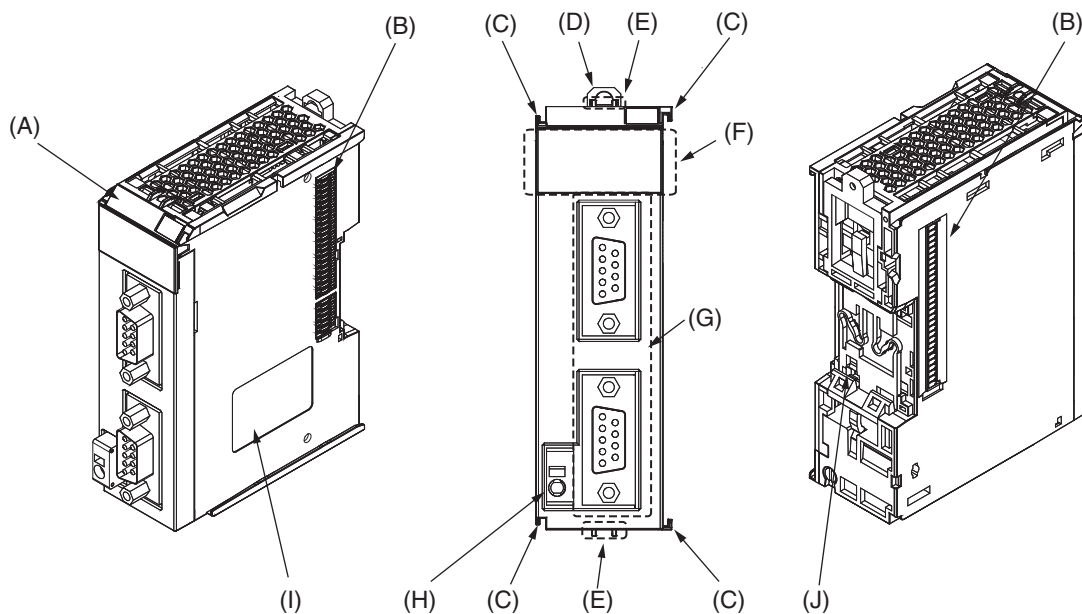

Letter	Name	Description
(A)	Marker attachment location	This is where the markers are attached. OMRON markers are pre-installed at the factory. You can also install commercially available markers.
(B)	NX bus connector	This connector is used to connect each Unit.
(C)	Unit hookup guides	These guides are used to connect two Units.
(D)	DIN Track mounting hooks	These hooks are used to mount the NX Unit to a DIN Track.
(E)	Protrusions for removing the Unit	These protrusions are to hold onto when you need to pull out the Unit.
(F)	Indicators	The indicators show the current operating status of the Unit.
(G)	D-Sub connector	This connector is used to connect the external serial communications device. This is the D-Sub connector plug. The top is port 1 and the bottom is port 2.
(H)	FG terminal	This is the external ground connection terminal. It is a screwless clamping terminal.
(I)	Unit specifications	The specifications of the Unit are given here.
(J)	DIN Track contact plate	This plate is connected internally to the functional ground terminal on the terminal block.

(Unit: mm)

Dimensions

NX-CIF101 and NX-CIF105

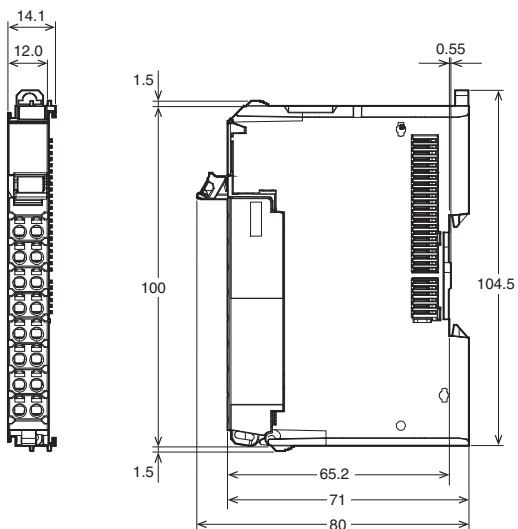

NX-CIF210

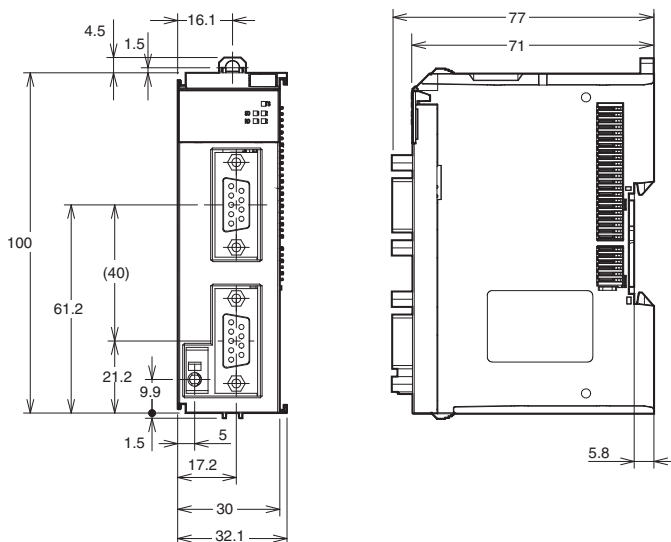

Installation Heights

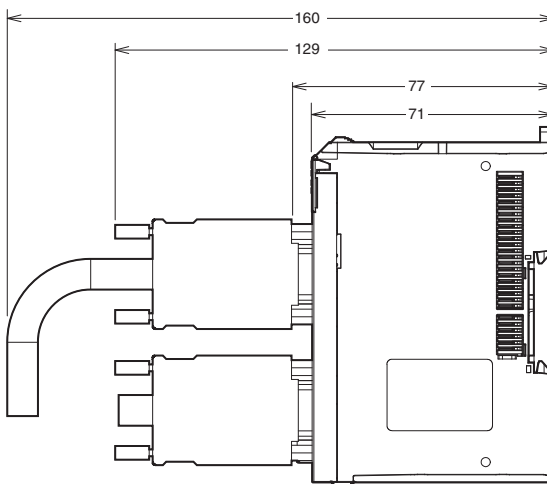

Related Manuals

Man. No	Model	Manual	Application	Description
W540	NX-CIF□□□	NX-series Communications Interface Units User's Manual	Learning how to use NX-series Communications Interface Units	The hardware, setup methods, and functions of the NX-series Communications Interface Unit are described.

Terms and Conditions Agreement

Read and understand this catalog.

Please read and understand this catalog before purchasing the products. Please consult your OMRON representative if you have any questions or comments.

Warranties.

(a) Exclusive Warranty. Omron's exclusive warranty is that the Products will be free from defects in materials and workmanship for a period of twelve months from the date of sale by Omron (or such other period expressed in writing by Omron). Omron disclaims all other warranties, express or implied.

(b) Limitations. OMRON MAKES NO WARRANTY OR REPRESENTATION, EXPRESS OR IMPLIED, ABOUT NON-INFRINGEMENT, MERCHANTABILITY OR FITNESS FOR A PARTICULAR PURPOSE OF THE PRODUCTS. BUYER ACKNOWLEDGES THAT IT ALONE HAS DETERMINED THAT THE PRODUCTS WILL SUITABLY MEET THE REQUIREMENTS OF THEIR INTENDED USE.

Omron further disclaims all warranties and responsibility of any type for claims or expenses based on infringement by the Products or otherwise of any intellectual property right. (c) Buyer Remedy. Omron's sole obligation hereunder shall be, at Omron's election, to (i) replace (in the form originally shipped with Buyer responsible for labor charges for removal or replacement thereof) the non-complying Product, (ii) repair the non-complying Product, or (iii) repay or credit Buyer an amount equal to the purchase price of the non-complying Product; provided that in no event shall Omron be responsible for warranty, repair, indemnity or any other claims or expenses regarding the Products unless Omron's analysis confirms that the Products were properly handled, stored, installed and maintained and not subject to contamination, abuse, misuse or inappropriate modification. Return of any Products by Buyer must be approved in writing by Omron before shipment. Omron Companies shall not be liable for the suitability or unsuitability or the results from the use of Products in combination with any electrical or electronic components, circuits, system assemblies or any other materials or substances or environments. Any advice, recommendations or information given orally or in writing, are not to be construed as an amendment or addition to the above warranty.

See <http://www.omron.com/global/> or contact your Omron representative for published information.

Limitation on Liability: Etc.

OMRON COMPANIES SHALL NOT BE LIABLE FOR SPECIAL, INDIRECT, INCIDENTAL, OR CONSEQUENTIAL DAMAGES, LOSS OF PROFITS OR PRODUCTION OR COMMERCIAL LOSS IN ANY WAY CONNECTED WITH THE PRODUCTS, WHETHER SUCH CLAIM IS BASED IN CONTRACT, WARRANTY, NEGLIGENCE OR STRICT LIABILITY.

Further, in no event shall liability of Omron Companies exceed the individual price of the Product on which liability is asserted.

Suitability of Use.

Omron Companies shall not be responsible for conformity with any standards, codes or regulations which apply to the combination of the Product in the Buyer's application or use of the Product. At Buyer's request, Omron will provide applicable third party certification documents identifying ratings and limitations of use which apply to the Product. This information by itself is not sufficient for a complete determination of the suitability of the Product in combination with the end product, machine, system, or other application or use. Buyer shall be solely responsible for determining appropriateness of the particular Product with respect to Buyer's application, product or system. Buyer shall take application responsibility in all cases.

NEVER USE THE PRODUCT FOR AN APPLICATION INVOLVING SERIOUS RISK TO LIFE OR PROPERTY OR IN LARGE QUANTITIES WITHOUT ENSURING THAT THE SYSTEM AS A WHOLE HAS BEEN DESIGNED TO ADDRESS THE RISKS, AND THAT THE OMRON PRODUCT(S) IS PROPERLY RATED AND INSTALLED FOR THE INTENDED USE WITHIN THE OVERALL EQUIPMENT OR SYSTEM.

Programmable Products.

Omron Companies shall not be responsible for the user's programming of a programmable Product, or any consequence thereof.

Performance Data.

Data presented in Omron Company websites, catalogs and other materials is provided as a guide for the user in determining suitability and does not constitute a warranty. It may represent the result of Omron's test conditions, and the user must correlate it to actual application requirements. Actual performance is subject to the Omron's Warranty and Limitations of Liability.

Change in Specifications.

Product specifications and accessories may be changed at any time based on improvements and other reasons. It is our practice to change part numbers when published ratings or features are changed, or when significant construction changes are made. However, some specifications of the Product may be changed without any notice. When in doubt, special part numbers may be assigned to fix or establish key specifications for your application. Please consult with your Omron's representative at any time to confirm actual specifications of purchased Product.

Errors and Omissions.

Information presented by Omron Companies has been checked and is believed to be accurate; however, no responsibility is assumed for clerical, typographical or proofreading errors or omissions.

2020.2

In the interest of product improvement, specifications are subject to change without notice.

OMRON Corporation
Industrial Automation Company

<http://www.ia.omron.com/>

(c)Copyright OMRON Corporation 2020 All Right Reserved.



SCATTERGOOD & JOHNSON LTD

ELECTRICAL ENGINEERING & FLUID CONTROL DISTRIBUTORS

Est.1899

At Scattergood & Johnson Ltd, we pride ourselves on being a technical distributor to specialist industries.

Working with a range of quality product suppliers across a number of specialist markets, we are not your average 'box shifter' - we are your technical and supply chain partner.

We fully support every product we sell - for free! Our internal team and external sales engineers can answer any product or application question, no matter the complexity.

Backing up this technical ability is a range of 50,000+ products available from stock for nationwide next day delivery (same day if required!), or you can collect what you need from any of our trade counters around the UK.

Select your specialist interest below to learn more about how we can help.

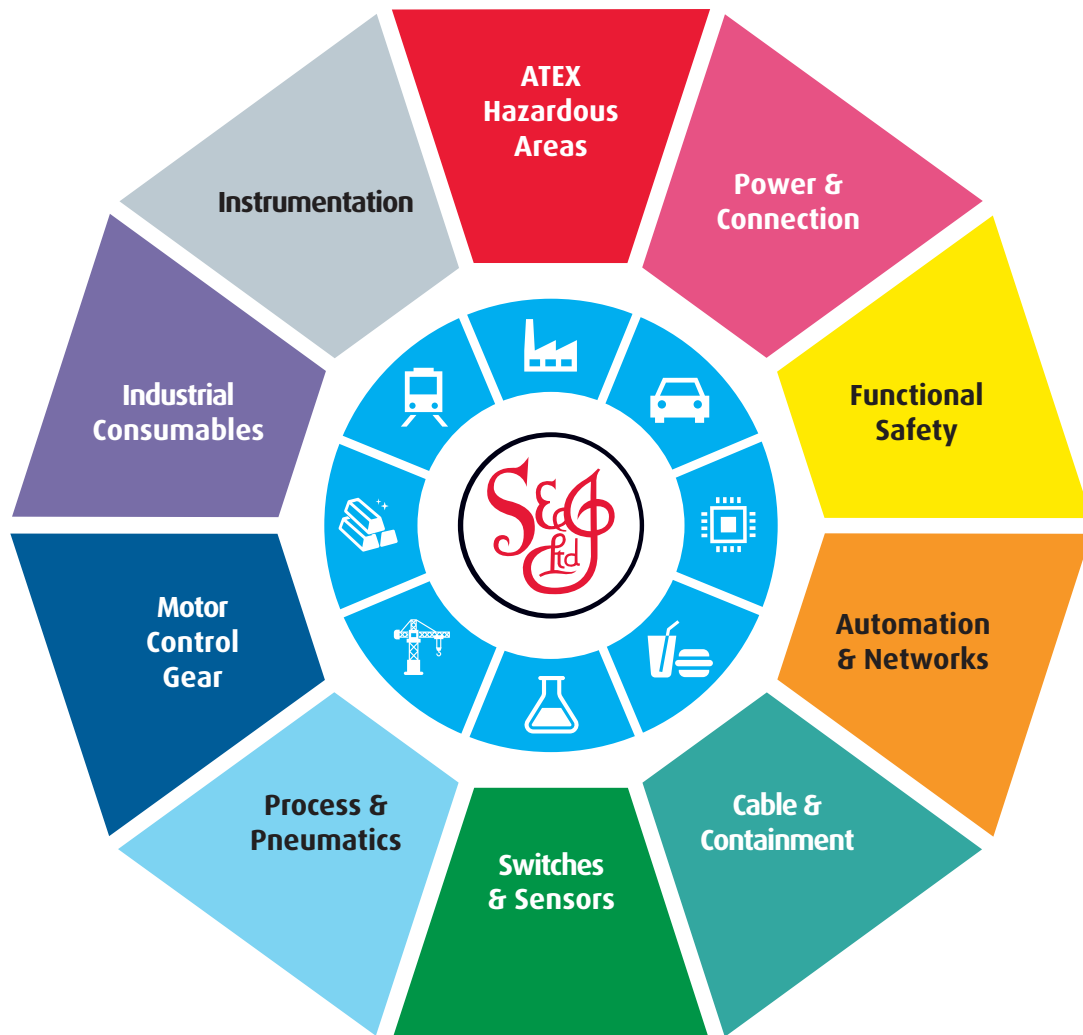

Online, In Branch and On the Road - Scattergood & Johnson Ltd, there when you need us.

www.scatts.co.uk