

# NX-series High-speed Analog Input Unit

# NX-HAD□□□

CSM\_NX-HAD\_\_\_DS\_E\_DITA\_4\_1

## Simultaneous sampling of 4 channels with sampling times down to 5 $\mu$ s

- NX-series High-speed Analog Input Unit
- Multi-range inputs: Voltage and current
- Highest resolution: 1/64,000



NX-HAD□□□

## Features

- Continuously samples analog input signals from 4 channels every 5  $\mu$ s, independent of the controller's task period
- AD conversion over multiple channels maintains synchronization and sampling speed, regardless of the number of channels
- Fully insulated channels suppress interference, enabling data collection with less noise effects
- Sampling starts by external trigger input
- Various trigger functions to specify the timing to acquire data
- Detachable terminals for easy maintenance
- Push-in connections speed up installation

EtherCAT® is a registered trademark and patented technology, licensed by Beckhoff Automation GmbH, Germany.

EtherNet/IP™ and DeviceNet™ are trademarks of ODVA.

Other company names and product names in this document are the trademarks or registered trademarks of their respective companies.

## System Configurations

### Connected to a CPU Unit

(D) Support Software  
Sysmac Studio

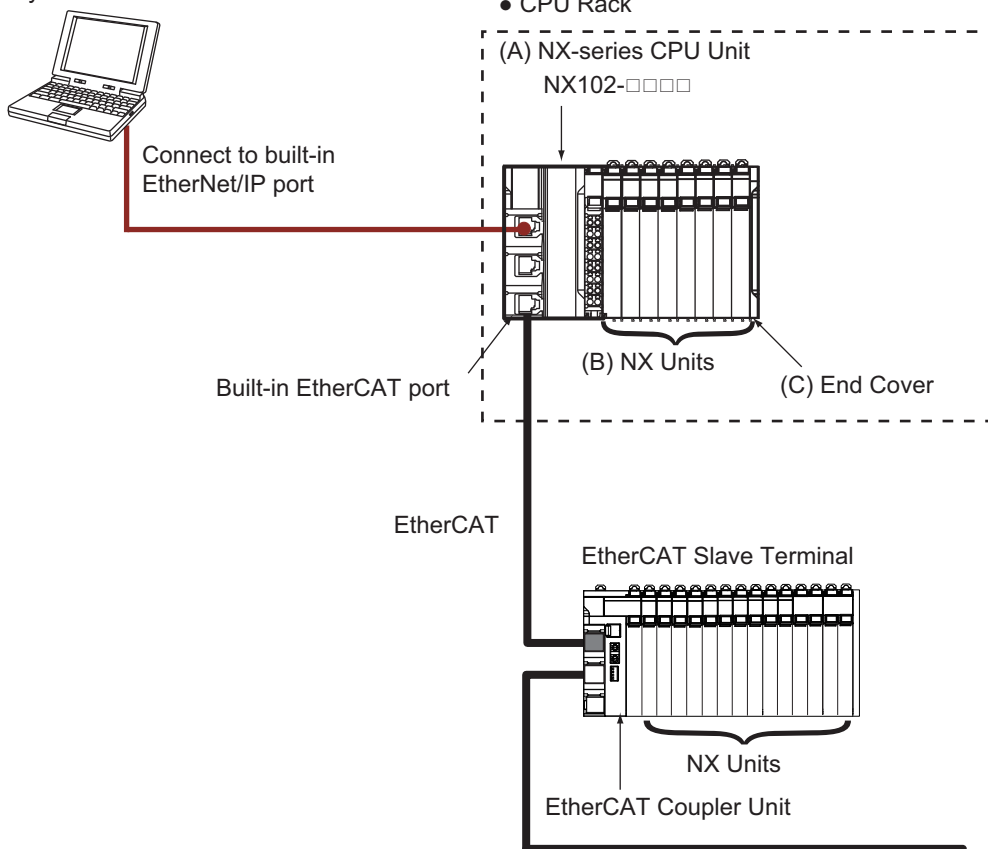

Letter	Item	Description
(A)	NX-series CPU Unit	The Unit that serves as the center of control for a Machine Automation Controller. It executes tasks, refreshes I/O for other Units and slaves, etc. NX Units can be connected to an NX102 CPU Unit.
(B)	NX Units	The NX Units perform I/O processing with connected external devices. The NX Units exchange data with the CPU Unit through I/O refreshing. A maximum of 32 NX Units can be connected to an NX102 CPU Unit.
(C)	End Cover	The End Cover is attached to the end of the CPU Rack.
(D)	Support Software (Sysmac Studio)	A computer software application for setting, programming, debugging, and troubleshooting NJ/NX/NY-series Controllers. For an NX102 CPU Unit, this application performs setting operation by making a connection to a built-in EtherNet/IP port.

## Connected to an EtherCAT Coupler Unit

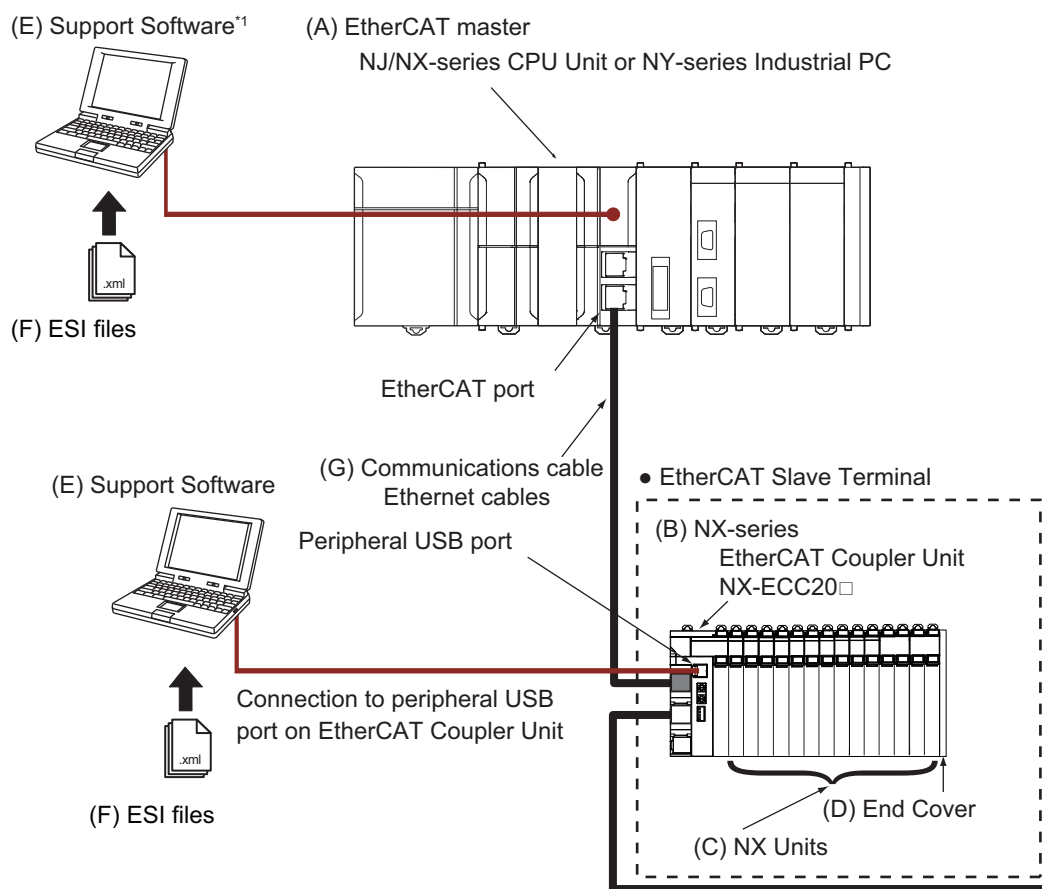

\*1. The connection method for the Support Software depends on the model of the CPU Unit or Industrial PC.

Letter	Item	Description
(A)	EtherCAT master <sup>*1</sup>	The EtherCAT master manages the network, monitors the status of slaves, and exchanges I/O data with slaves. The High-speed Analog Input Units can be connected with the following OMRON master products. <ul style="list-style-type: none"> <li>• NJ/NX-series CPU Units</li> <li>• NY-series Industrial PCs (NX5□□-1□00 and NY5□□5□00)</li> </ul> They cannot be connected to other manufacturers' master products, or other OMRON master products.
(B)	EtherCAT Coupler Unit	The EtherCAT Coupler Unit serves as an interface for process data communications on the EtherCAT network between the NX Units and the EtherCAT master. The I/O data for the NX Units is accumulated in the EtherCAT Coupler Unit and then all of the data is exchanged with the EtherCAT master at the same time. The EtherCAT Coupler Unit can also perform message communications (SDO communications) with the EtherCAT master.
(C)	NX Units	The NX Units perform I/O processing with connected external devices. The NX Units perform process data communications with the EtherCAT master through the EtherCAT Coupler Unit.
(D)	End Cover	The End Cover is attached to the end of the Slave Terminal.
(E)	Support Software <sup>*2</sup>	The Support Software runs on a personal computer and it is used to configure the EtherCAT network and EtherCAT Slave Terminal, and to program, monitor, and troubleshoot the Controllers.
(F)	ESI (EtherCAT Slave Information) file	The ESI file contains information that is unique to the EtherCAT Slave Terminal in XML format. You can load an ESI file into the Support Software to easily allocate Slave Terminal process data and make other settings. The ESI files for OMRON EtherCAT slaves are installed in the Support Software. You can obtain the ESI files for the latest models through the Support Software's automatic update function.
(G)	Communications cable	Use a double-shielded cable with aluminum tape and braiding of Ethernet category 5 (100Base-TX) or higher, and use straight wiring.

\*1. An Ether CAT Slave Terminal cannot be connected to any of the OMRON CJ1W-NC□81/□82 Position Control Units even though they can operate as EtherCAT masters.

\*2. The term Support Software indicates software that is provided by OMRON.

## Ordering Information

### High-speed Analog Input Units

The models and outline of specifications are given below.

Analog input section					Trigger input section		I/O refreshing method	Model
Number of points	Input range	Resolution	Input method	Conversion time	Number of points	Internal I/O common		
4	-10 to 10 V -5 to 5 V 0 to 10 V 0 to 5 V 1 to 5 V 0 to 20 mA 4 to 20 mA	<ul style="list-style-type: none"> <li>Input range of -10 to 10 V or -5 to 5 V: 1/64,000 (full scale)</li> <li>Other input range: 1/32,000 (full scale)</li> </ul>	Differential input	5 μs per channel	4	NPN	Synchronous I/O refreshing	NX-HAD401
						PNP		NX-HAD402

### Optional Products

Product name	Specifications	Model
Unit/Terminal Block Coding Pin	For 10 units (30 terminal block pins and 30 unit pins)	NX-AUX02

Product name	Specifications			Model
	No. of terminals	Ground terminal mark	Terminal current capacity	
Terminal Block	16	None	10 A	NX-TBA162
				NX-TBB162

### Accessories

Not included.

### Collection of software functional components Sysmac Library

Please download it from following URL and install to Sysmac Studio.

[http://www.ia.omron.com/sysmac\\_library/](http://www.ia.omron.com/sysmac_library/)

Product name	Specifications	Model
High-Speed Analog Inspection Library	The High-speed Analog Inspection Library records analog input values acquired by the NX series High-speed Analog Input Units in time. This library provides functions required for product inspections during production processes, including calculation of feature values (e.g., maximum, minimum, and mean), comparison with master data, and data file storage.	SYSMAC-XR016

## General Specifications

This section provides the general specifications of the High-speed Analog Input Units.

Item		Specification
<b>Enclosure</b>		Mounted in a panel
<b>Grounding methods</b>		Ground of 100 Ω or less
<b>Operating environment</b>	<b>Ambient operating temperature</b>	0 to 55°C
	<b>Ambient operating humidity</b>	10% to 95% (with no condensation or icing)
	<b>Atmosphere</b>	Must be free from corrosive gases.
	<b>Ambient storage temperature</b>	-25 to 70°C (with no condensation or icing)
	<b>Altitude</b>	2,000 m max.
	<b>Pollution degree</b>	2 or less: Meets IEC 61010-2-201.
	<b>Noise immunity</b>	Conforms to IEC 61000-4-4, 2 kV (power supply line)
	<b>Overvoltage category</b>	Category II: Meets IEC 61010-2-201.
	<b>EMC immunity level</b>	Zone B
	<b>Vibration resistance</b>	Conforms to IEC 60068-2-6. 5 to 8.4 Hz with amplitude of 3.5 mm, 8.4 to 150 Hz, acceleration of 9.8 m/s <sup>2</sup> 100 min each in X, Y, and Z directions (10 sweeps of 10 min each = 100 min total)
	<b>Shock resistance</b>	Conforms to IEC 60068-2-27, 147 m/s <sup>2</sup> , 3 times each in X, Y, and Z directions
	<b>Insulation resistance</b>	Refer to the individual specifications of NX Units.
<b>Dielectric strength</b>	Refer to the individual specifications of NX Units.	
<b>Applicable standards</b>		cULus: Listed (UL61010-2-201), ANSI/ISA 12.12.01, EU: EN 61131-2, RCM, KC (KC Registration), and EAC, NK, LR

**Note: 1.** The specifications of insulation resistance and dielectric strength vary with NX Unit Models.

**2.** Refer to the OMRON website ([www.ia.omron.com](http://www.ia.omron.com)) or ask your OMRON representative for the most recent applicable standards for each model.

## Specifications of Individual Units

### NX-HAD401

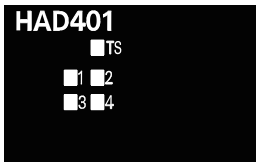
<b>Unit name</b>		High-speed Analog Input Unit	<b>Model</b>	NX-HAD401	
<b>External connection terminals</b>		Screwless clamping terminal block (16 terminals ×2)			
<b>I/O refreshing method</b>		Synchronous I/O refreshing			
<b>Indicators</b>		TS indicator, IN indicator 			
<b>Analog input section</b>	<b>Number of points</b>	4 points	<b>Trigger input section</b>	<b>Number of points</b>	4 points
	<b>Input method</b>	Differential input		<b>Internal I/O common</b>	NPN
	<b>Input range</b>	Voltage: • -10 to 10 V • -5 to 5 V • 0 to 10 V • 0 to 5 V • 1 to 5 V Current: • 0 to 20 mA • 4 to 20 mA		<b>Rated input voltage</b>	24 VDC (20.4 to 28.8 VDC)
	<b>Input conversion range</b>	• Input range of -10 to 10 V or -5 to 5 V -1% to 101% (full scale) • Other input ranges -2% to 102% (full scale)		<b>Input current</b>	3.5 mA typical (24 VDC)
	<b>Absolute maximum rating</b>	Voltage: ±15 V Input current: ±30 mA		<b>ON voltage/ON current</b>	15 VDC min./3 mA min. (between IOV and each signal)
	<b>Input impedance</b>	Voltage: 1 MΩ min. Current: 250 Ω		<b>OFF voltage/OFF current</b>	5 VDC max./1 mA max. (between IOV and each signal)
	<b>Resolution</b>	• Input range of -10 to 10 V or -5 to 5 V 1/64000 (full scale) • Other input ranges 1/32000 (full scale)		<b>ON/OFF response time</b>	1 μs max./1 μs max.
	<b>Overall accuracy</b>	25°C ±0.1% (full scale) 0 to 55°C ±0.2% (full scale)		<b>Input filter time</b>	No filter, 4 μs, 8 μs (default), 16 μs, 32 μs, 64 μs, 128 μs, 256 μs
	<b>Conversion time</b>	5 μs per channel <sup>1)</sup>			
<b>Dimensions</b>	24 (W) × 100 (H) × 71 (D)	<b>Isolation method</b>	Between the analog input and the NX bus: Power = Transformer, Signal = Digital isolator Between analog inputs: Power = Transformer, Signal = Digital isolator Between the trigger input and the NX bus: Signal = Digital isolator Between the analog input and the trigger input: Power = Transformer, Signal = Digital isolator		
<b>Insulation resistance</b>	20 MΩ min. between isolated circuits (at 100 VDC)	<b>Dielectric strength</b>	510 VAC between isolated circuits for 1 minute at a leakage current of 5 mA max.		
<b>I/O power supply method</b>	Supply from the NX Bus	<b>Current capacity of I/O power supply terminals</b>	IOV: 0.1 A max. per terminal IOG: 0.1 A max. per terminal		
<b>NX Unit power consumption</b>	• Connected to a CPU Unit 3.30 W max. • Connected to a Communications Coupler Unit 2.95 W max.	<b>Current consumption from I/O power supply</b>	30 mA max.		
<b>Weight</b>	140 g max.				

# NX-series High-speed Analog Input Unit NX-HAD□□□

### Circuit Configuration

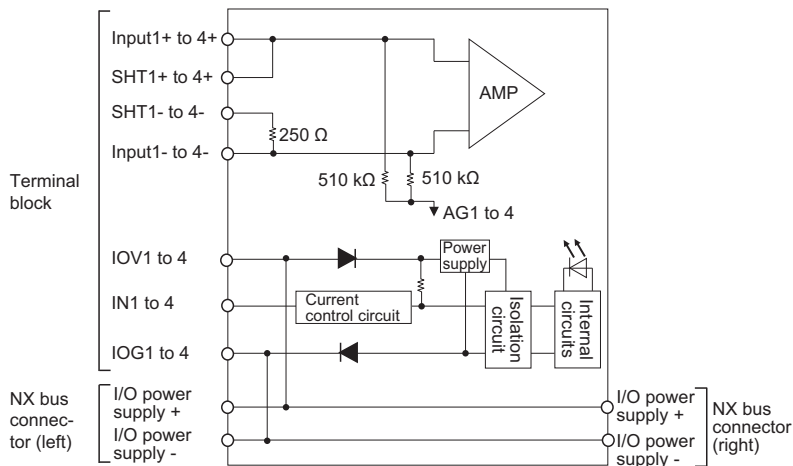

The following channels are individually isolated.

- Input1+, Input1-, SHT1+, SHT1-
- Input2+, Input2-, SHT2+, SHT2-
- Input3+, Input3-, SHT3+, SHT3-
- Input4+, Input4-, SHT4+, SHT4-

### Installation orientation and restrictions<sup>2</sup>

- Installation orientation:
- Connected to a CPU Unit  
Possible in upright installation.
  - Connected to a Communications Coupler Unit  
Possible in upright installation.
- Restrictions: No restrictions

### Terminal connection diagram

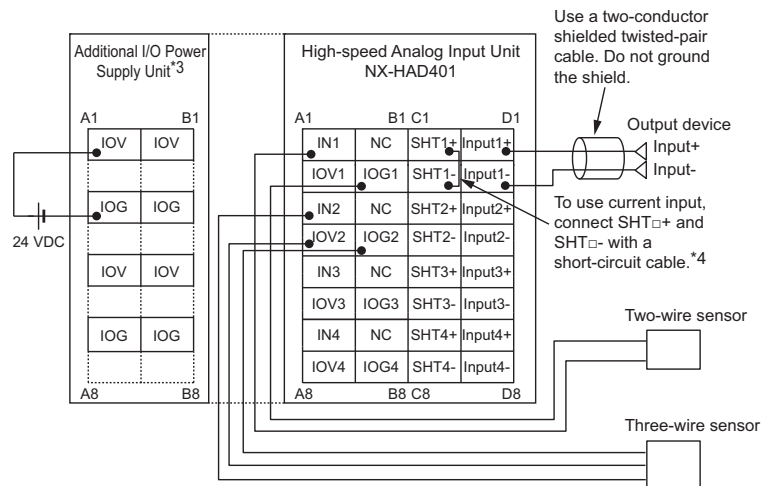

### Input disconnection detection<sup>5</sup>

- When the input range is 1 to 5 V or 4 to 20 mA: Supported
- Other input range: Not supported

- \*1. This is the minimum value. The Units perform conversion in the sampling period determined based on the Number of Samplings Setting. The sampling period must be set to this value or longer.
- \*2. The following Unit cannot be connected next to the Unit.
  - Relay Output Unit (NX-OC□□□□)
- \*3. Besides the Additional I/O Power Supply Unit, there are Units that can supply I/O power to the NX bus. For example, you can use a Connected Communications Coupler Unit. If you use this Unit to supply I/O power to the High-speed Analog Input Units, the Additional I/O Power Supply Unit is unnecessary. The Additional I/O Power Supply Unit is also unnecessary if you do not use the trigger inputs of the High-speed Analog Input Units.
- \*4. Short-circuit cables are not included in the product. The cable length must be 4 cm or less and allow for wiring to the screwless clamping terminal block. Be sure to use cables and ferrules that are applicable to the screwless clamping terminal block. If the cable is too long, the analog input values may not be accurate.
- \*5. To use this function, set the Disconnection Detection Enable/Disable to Enable.

## NX-series High-speed Analog Input Unit NX-HAD□□□

## NX-HAD402

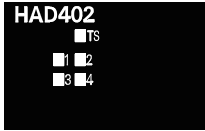
<b>Unit name</b>		High-speed Analog Input Unit	<b>Model</b>	NX-HAD402	
<b>External connection terminals</b>		Screwless clamping terminal block (16 terminals ×2)			
<b>I/O refreshing method</b>		Synchronous I/O refreshing			
<b>Indicators</b>		TS indicator, IN indicator 			
<b>Analog input section</b>	<b>Number of points</b>	4 points	<b>Trigger input section</b>	<b>Number of points</b>	4 points
	<b>Input method</b>	Differential input		<b>Internal I/O common</b>	PNP
	<b>Input range</b>	Voltage: • -10 to 10 V • -5 to 5 V • 0 to 10 V • 0 to 5 V • 1 to 5 V Current: • 0 to 20 mA • 4 to 20 mA		<b>Rated input voltage</b>	24 VDC (20.4 to 28.8 VDC)
	<b>Input conversion range</b>	• Input range of -10 to 10 V or -5 to 5 V -1% to 101% (full scale) • Other input ranges -2% to 102% (full scale)		<b>Input current</b>	3.5 mA typical (24 VDC)
	<b>Absolute maximum rating</b>	Voltage: ±15 V Input current: ±30 mA		<b>ON voltage/ON current</b>	15 VDC min./3 mA min. (between IOG and each signal)
	<b>Input Impedance</b>	Voltage: 1 MΩ min. Current: 250 Ω		<b>OFF voltage/OFF current</b>	5 VDC max./1 mA max. (between IOG and each signal)
	<b>Resolution</b>	• Input range of -10 to 10 V or -5 to 5 V 1/64000 (full scale) • Other input ranges 1/32000 (full scale)		<b>ON/OFF response time</b>	1 μs max./1 μs max.
	<b>Overall accuracy</b>	25°C ±0.1% (full scale) 0 to 55°C ±0.2% (full scale)		<b>Input filter time</b>	No filter, 4 μs, 8 μs (default), 16 μs, 32 μs, 64 μs, 128 μs, 256 μs
	<b>Conversion time</b>	5 μs per channel <sup>1</sup>			
	<b>Dimensions</b>	24 (W) × 100 (H) × 71 (D)		<b>Isolation method</b>	Between the analog input and the NX bus: Power = Transformer, Signal = Digital isolator Between analog inputs: Power = Transformer, Signal = Digital isolator Between the trigger input and the NX bus: Signal = Digital isolator Between the analog input and the trigger input: Power = Transformer, Signal = Digital isolator
<b>Insulation resistance</b>	20 MΩ min. between isolated circuits (at 100 VDC)	<b>Dielectric strength</b>	510 VAC between isolated circuits for 1 minute at a leakage current of 5 mA max.		
<b>I/O power supply method</b>	Supply from the NX bus	<b>Current capacity of I/O power supply terminals</b>	IOV: 0.1 A max. per terminal IOG: 0.1 A max. per terminal		
<b>NX Unit power consumption</b>	• Connected to a CPU Unit 3.30 W max. • Connected to a Communications Coupler Unit 2.95 W max.	<b>Current consumption from I/O power supply</b>	30 mA max.		
<b>Weight</b>	140 g max.				

# NX-series High-speed Analog Input Unit NX-HAD□□□□

**Circuit Configuration**

The following channels are individually isolated.

- Input1+, Input1-, SHT1+, SHT1-
- Input2+, Input2-, SHT2+, SHT2-
- Input3+, Input3-, SHT3+, SHT3-
- Input4+, Input4-, SHT4+, SHT4-

**Installation orientation and restrictions<sup>2</sup>**

Installation orientation:

- Connected to a CPU Unit  
Possible in upright installation.
- Connected to a Communications Coupler Unit  
Possible in upright installation.

Restrictions: No restrictions

**Terminal connection diagram**

Use a two-conductor shielded twisted-pair cable. Do not ground the shield.

To use current input, connect SHT□+ and SHT□- with a short-circuit cable.\*4

**Input disconnection detection<sup>5</sup>**

- When the input range is 1 to 5 V or 4 to 20 mA: Supported
- Other input range: Not supported

- \*1. This is the minimum value. The Units perform conversion in the sampling period determined based on the Number of Samplings Setting. The sampling period must be set to this value or longer.
- \*2. The following Unit cannot be connected next to the Unit.
  - Relay Output Unit (NX-OC□□□□)
- \*3. Besides the Additional I/O Power Supply Unit, there are Units that can supply I/O power to the NX bus. For example, you can use a Connected Communications Coupler Unit. If you use this Unit to supply I/O power to the High-speed Analog Input Units, the Additional I/O Power Supply Unit is unnecessary. The Additional I/O Power Supply Unit is also unnecessary if you do not use the trigger inputs of the High-speed Analog Input Units.
- \*4. Short-circuit cables are not included in the product. The cable length must be 4 cm or less and allow for wiring to the screwless clamping terminal block. Be sure to use cables and ferrules that are applicable to the screwless clamping terminal block. If the cable is too long, the analog input values may not be accurate.
- \*5. To use this function, set the Disconnection Detection Enable/Disable to Enable.

## Version Information

### Connected to a CPU Unit

Refer to the user's manual for the CPU Unit for details on the CPU Units to which NX Units can be connected.

NX Unit		Corresponding unit versions/versions *	
Model	Unit version	CPU Unit	Sysmac Studio
NX-HAD401	Ver.1.0	Ver. 1.18	Ver.1.23
NX-HAD402			

\* Some Units do not have all of the versions given in the above table. If a Unit does not have the specified version, support is provided by the oldest available version after the specified version. Refer to the user's manuals for the specific Units for the relation between models and versions.

### Connected to an EtherCAT Coupler Unit

The items that are used in the version combination table are given below.

NX Unit		Corresponding unit versions/versions *		
Model	Unit version	EtherCAT Coupler Unit	CPU Unit or Industrial PC	Sysmac Studio
NX-HAD401	Ver.1.0	Ver.1.0	Ver. 1.18	Ver.1.23
NX-HAD402				

\* Some Units do not have all of the versions given in the above table. If a Unit does not have the specified version, support is provided by the oldest available version after the specified version. Refer to the user's manuals for the specific Units for the relation between models and versions.

NX-series High-speed Analog Input Unit NX-HAD□□□

## External Interface

This section describes the names and functions of the parts of the High-speed Analog Input Units.

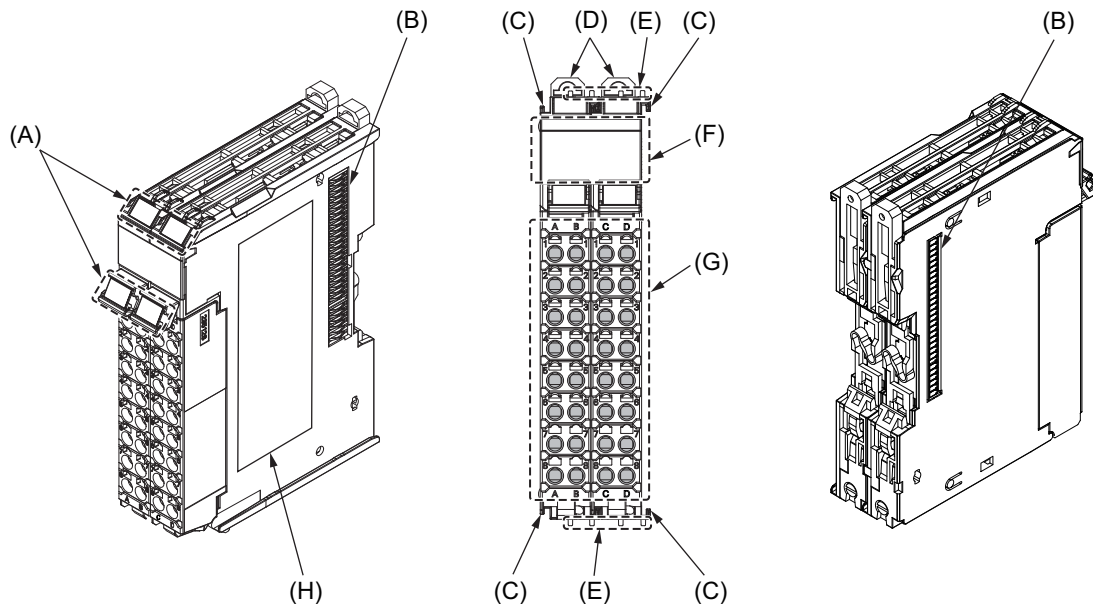

Letter	Name	Description
(A)	Marker attachment locations	The locations where markers are attached. The markers made by OMRON are installed for the factory setting. Commercially available markers can also be installed.
(B)	NX bus connector	This connector is used to connect each Unit.
(C)	Unit hookup guides	These guides are used to connect two Units.
(D)	DIN Track mounting hooks	These hooks are used to mount the NX Unit to a DIN Track.
(E)	Protrusions for removing the Unit	The protrusions to hold when removing the Unit.
(F)	Indicators	The indicators show the current operating status of the Unit.
(G)	Terminal block	The terminal block is used to connect external devices.
(H)	Unit specifications	The specifications of the Unit are given.

Refer to *Installation* in the hardware user's manual for the connected CPU Unit or the user's manual for the Communications Coupler Unit for details on attaching markers.

Refer to *NX-series Analog I/O Units User's Manual for High-speed Analog Input Units (W592)* for details on the indicators.

Refer to *NX-series Analog I/O Units User's Manual for High-speed Analog Input Units (W592)* for details on the terminal blocks.

## Terminal Blocks

### Applicable Terminal Blocks

The following indicates the terminal blocks that are applicable to the High-speed Analog Input Units.

Unit model number	Terminal blocks			
	Model	Number of terminals	Ground terminal mark	Current capacity
NX-HAD40E	NX-TBA161 NX-TBB161	16	Not provided	4 A
	NX-TBA162 NX-TBB162	16	Not provided	10 A

NX-TBA162 and NX-TBB162 are installed for the factory setting.

## Applicable Wires

### Using Ferrules

If you use ferrules, attach the twisted wires to them.

Observe the application instructions for your ferrules for the wire stripping length when attaching ferrules.

Always use plated one-pin ferrules. Do not use unplated ferrules or two-pin ferrules.

The applicable ferrules, wires, and crimping tools are given in the following table.

Terminal type	Manufacturer	Ferrule model	Applicable wire (mm <sup>2</sup> (AWG))	Crimping tool	
All terminals except ground terminals	Phoenix Contact	AI0,34-8	0.34 (#22)	Phoenix Contact (Applicable wire sizes are given in parentheses.) CRIMPFOX 6 (0.25 to 6 mm <sup>2</sup> , AWG24 to 10)	
		AI0,5-8	0.5 (#20)		
		AI0,5-10			
		AI0,75-8	0.75 (#18)		
		AI0,75-10			
		AI1,0-8	1.0 (#18)		
		AI1,0-10			
		AI1,5-8	1.5 (#16)		
AI1,5-10					
Ground terminals		AI2,5-10	2.0 <sup>*1</sup>		
All terminals except ground terminals	Weidmuller	H0.14/12	0.14 (#26)		Weidmuller (Applicable wire sizes are given in parentheses.) PZ6 Roto (0.14 to 6 mm <sup>2</sup> , AWG26 to 10)
		H0.25/12	0.25 (#24)		
		H0.34/12	0.34 (#22)		
		H0.5/14	0.5 (#20)		
		H0.5/16			
		H0.75/14	0.75 (#18)		
		H0.75/16			
		H1.0/14	1.0 (#18)		
		H1.0/16			
		H1.5/14	1.5 (#16)		
H1.5/16					

\*1. Some AWG14 wires exceed 2.0 mm<sup>2</sup> and cannot be used in the screwless clamping terminal block.

When you use any ferrules other than those in the above table, crimp them to the twisted wires so that the following processed dimensions are achieved.

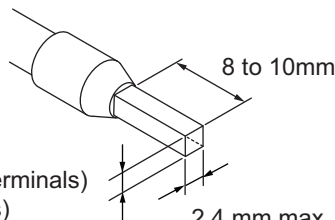

1.6 mm max. (except ground terminals)  
2.0 mm max. (ground terminals)

2.4 mm max. (except ground terminals)  
2.7 mm max. (ground terminals)

### Using Twisted or Solid Wires

If you use twisted wires or solid wires, use the following table to determine the correct wire specifications.

Terminals		Wire type				Wire size	Conductor length (stripping length)
Classification	Current capacity	Twisted wires		Solid wire			
		Plated	Unplated	Plated	Unplated		
All terminals except ground terminals	2 A max.	Possible	Possible	Possible	Possible	0.08 to 1.5 mm <sup>2</sup> (AWG28 to 16)	8 to 10 mm
	Greater than 2 A and 4 A or less		Not possible	Possible <sup>*1</sup>	Not possible		
Greater than 4 A	Possible <sup>*1</sup>	Not possible		Not possible			
Ground terminals	---	Possible	Possible	Possible <sup>*2</sup>	Possible <sup>*2</sup>	2.0 mm <sup>2</sup>	9 to 10 mm

\*1. Secure wires to the screwless clamping terminal block. Refer to *NX-series Analog I/O Units User's Manual for High-speed Analog Input Units (W592)* for how to secure wires.

\*2. With the NX-TB□□□1 Terminal Block, use twisted wires to connect the ground terminal. Do not use a solid wire.

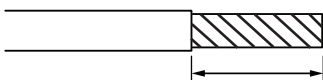

Conductor length (stripping length)

# Dimensions

(Unit: mm)

## 24 mm Width

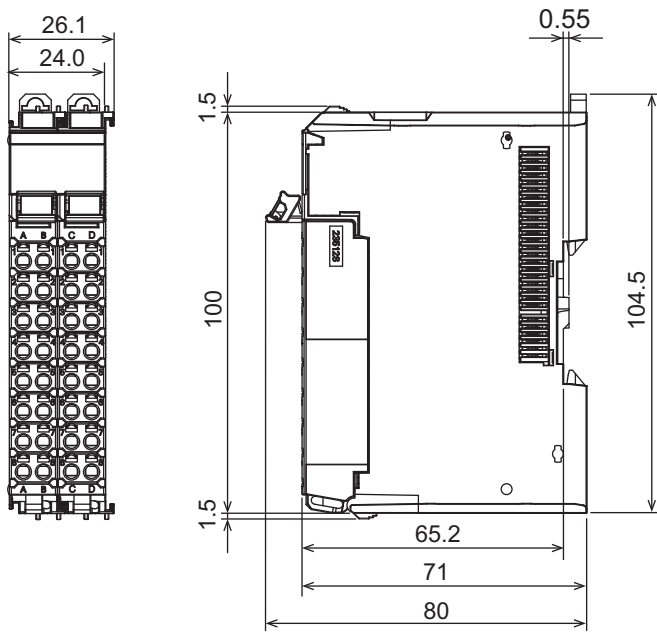

## NX-series High-speed Analog Input Unit NX-HAD□□□

## Related Manuals

The following table shows related manuals. Use these manuals for reference.

Manual name	Cat. No.	Model	Application	Description
NX-series Analog I/O Units User's Manual for High-speed Analog Input Units	W592	NX-HAD□□□	Learning how to use NX-series High-speed Analog Input Units	The hardware, setup methods, and functions of the NX-series High-speed Analog Input Units are described.
NX-series Data Reference Manual	W525	NX-□□□□□□	Referencing lists of the data that is required to configure systems with NX-series Units.	Lists of the power consumptions, weights, and other NX Unit data that is required to configure systems with NX-series Units are provided.
NX-series System Units User's Manual	W523	NX-PD1□□□ NX-PF0□□□ NX-PC0□□□ NX-TBX01	Learning how to use NX-series System Units.	The hardware and functions of the NX-series System Units are described.
Sysmac Studio Version 1 Operation Manual	W504	SYSMAC-SE2□□□	Learning about the operating procedures and functions of the Sysmac Studio.	Describes the operating procedures of the Sysmac Studio.
Sysmac Library User's Manual for High-speed Analog Inspection Library	W607	SYSMAC-XR016	Learning the function block specifications in the High-speed Analog Inspection Library.	Information required to use the High-speed Analog Inspection Library is described.
NJ/NX-series Troubleshooting Manual	W503	NX701-□□□□ NX102-□□□□ NX1P2-□□□□ NJ501-□□□□ NJ301-□□□□ NJ101-□□□□	Learning about the errors that may be detected in an NJ/NX-series Controller.	Concepts on managing errors that may be detected in an NJ/NX-series Controller and information on individual errors are described.
NY-series Troubleshooting Manual	W564	NY532-1□□□ NY512-1□□□	Learning about the errors that may be detected in an NY-series Industrial PC.	Concepts on managing errors that may be detected in an NY-series Controller and information on individual errors are described.
NX-series EtherCAT® Coupler Unit User's Manual	W519	NX-ECC□□□	Learning how to use the NX-series EtherCAT Coupler Unit and EtherCAT Slave Terminals.	The following items are described: the overall system and configuration methods of an EtherCAT Slave Terminal (which consists of an NX-series EtherCAT Coupler Unit and NX Units), and information on hardware, setup, and functions to set up, control, and monitor NX Units through EtherCAT.
NX-series CPU Unit Hardware User's Manual	W535	NX701-□□□□	Learning the basic specifications of the NX701 CPU Units, including introductory information, designing, installation, and maintenance. Mainly hardware information is provided.	An introduction to the entire NX701 system is provided along with the following information on the CPU Unit. <ul style="list-style-type: none"> <li>• Features and system configuration</li> <li>• Introduction</li> <li>• Part names and functions</li> <li>• General specifications</li> <li>• Installation and wiring</li> <li>• Maintenance and inspection</li> </ul>
NX-series NX102 CPU Unit Hardware User's Manual	W593	NX102-□□□□	Learning the basic specifications of the NX102 CPU Units, including introductory information, designing, installation, and maintenance. Mainly hardware information is provided.	An introduction to the entire NX102 system is provided along with the following information on the CPU Unit. <ul style="list-style-type: none"> <li>• Features and system configuration</li> <li>• Introduction</li> <li>• Part names and functions</li> <li>• General specifications</li> <li>• Installation and wiring</li> <li>• Maintenance and Inspection</li> </ul>
NX-series NX1P2 CPU Unit Hardware User's Manual	W578	NX1P2-□□□□	Learning the basic specifications of the NX1P2 CPU Units, including introductory information, designing, installation, and maintenance. Mainly hardware information is provided.	An introduction to the entire NX1P2 system is provided along with the following information on the CPU Unit. <ul style="list-style-type: none"> <li>• Features and system configuration</li> <li>• Introduction</li> <li>• Part names and functions</li> <li>• General specifications</li> <li>• Installation and wiring</li> <li>• Maintenance and Inspection</li> </ul>

## NX-series High-speed Analog Input Unit NX-HAD□□□

Manual name	Cat. No.	Model	Application	Description
NJ-series CPU Unit Hardware User's Manual	W500	NJ501-□□□□ NJ301-□□□□ NJ101-□□□□	Learning the basic specifications of the NJ-series CPU Units, including introductory information, designing, installation, and maintenance. Mainly hardware information is provided.	An introduction to the entire NJ-series system is provided along with the following information on the CPU Unit. <ul style="list-style-type: none"> <li>• Features and system configuration</li> <li>• Introduction</li> <li>• Part names and functions</li> <li>• General specifications</li> <li>• Installation and wiring</li> <li>• Maintenance and inspection</li> </ul>
NY-series IPC Machine Controller Industrial Panel PC Hardware User's Manual	W557	NY532-1□□□	Learning the basic specifications of the NY-series Industrial Panel PCs, including introductory information, designing, installation, and maintenance. Mainly hardware information is provided.	An introduction to the entire NY-series system is provided along with the following information on the Industrial Panel PC. <ul style="list-style-type: none"> <li>• Features and system configuration</li> <li>• Introduction</li> <li>• Part names and functions</li> <li>• General specifications</li> <li>• Installation and wiring</li> <li>• Maintenance and inspection</li> </ul>
NY-series IPC Machine Controller Industrial Box PC Hardware User's Manual	W556	NY512-1□□□	Learning the basic specifications of the NY-series Industrial Box PCs, including introductory information, designing, installation, and maintenance. Mainly hardware information is provided.	An introduction to the entire NY-series system is provided along with the following information on the Industrial Box PC. <ul style="list-style-type: none"> <li>• Features and system configuration</li> <li>• Introduction</li> <li>• Part names and functions</li> <li>• General specifications</li> <li>• Installation and wiring</li> <li>• Maintenance and inspection</li> </ul>
NJ/NX-series CPU Unit Software User's Manual	W501	NX701-□□□□ NX102-□□□□ NX1P2-□□□□ NJ501-□□□□ NJ301-□□□□ NJ101-□□□□	Learning how to program and set up an NJ/NX-series CPU Unit. Mainly software information is provided.	The following information is provided on a Controller built with an NJ/NX-series CPU Unit. <ul style="list-style-type: none"> <li>• CPU Unit operation</li> <li>• CPU Unit features</li> <li>• Initial settings</li> <li>• Programming based on IEC 61131-3 language specifications</li> </ul>
NY-series IPC Machine Controller Industrial Panel PC / Industrial Box PC Software User's Manual	W558	NY532-1□□□ NY512-1□□□	Learning how to program and set up the Controller functions of an NY-series Industrial PC.	The following information is provided on the NY-series Controller functions. <ul style="list-style-type: none"> <li>• Controller operation</li> <li>• Controller features</li> <li>• Controller settings</li> <li>• Programming based on IEC 61131-3 language specifications</li> </ul>
NJ/NX-series CPU Unit Built-in EtherCAT® Port User's Manual	W505	NX701-□□□□ NX102-□□□□ NX1P2-□□□□ NJ501-□□□□ NJ301-□□□□ NJ101-□□□□	Using the built-in EtherCAT port on an NJ/NX-series CPU Unit.	Information on the built-in EtherCAT port is provided. This manual provides an introduction and provides information on the configuration, features, and setup.
NY-series IPC Machine Controller Industrial Panel PC / Industrial Box PC Built-in EtherCAT® Port User's Manual	W562	NY532-1□□□ NY512-1□□□	Using the built-in EtherCAT port in an NY-series Industrial PC.	Information on the built-in EtherCAT port is provided. This manual provides an introduction and provides information on the configuration, features, and setup.
NJ/NX-series Instructions Reference Manual	W502	NX701-□□□□ NX102-□□□□ NX1P2-□□□□ NJ501-□□□□ NJ301-□□□□ NJ101-□□□□	Learning detailed specifications on the basic instructions of an NJ/NX-series CPU Unit.	The instructions in the instruction set (IEC 61131-3 specifications) are described.
NY-series Instructions Reference Manual	W560	NY532-1□□□ NY512-1□□□	Learning detailed specifications on the basic instructions of an NY-series Industrial PC.	The instructions in the instruction set (IEC 61131-3 specifications) are described.

## Terms and Conditions Agreement

### Read and understand this catalog.

Please read and understand this catalog before purchasing the products. Please consult your OMRON representative if you have any questions or comments.

### Warranties.

(a) Exclusive Warranty. Omron's exclusive warranty is that the Products will be free from defects in materials and workmanship for a period of twelve months from the date of sale by Omron (or such other period expressed in writing by Omron). Omron disclaims all other warranties, express or implied.

(b) Limitations. OMRON MAKES NO WARRANTY OR REPRESENTATION, EXPRESS OR IMPLIED, ABOUT NON-INFRINGEMENT, MERCHANTABILITY OR FITNESS FOR A PARTICULAR PURPOSE OF THE PRODUCTS. BUYER ACKNOWLEDGES THAT IT ALONE HAS DETERMINED THAT THE PRODUCTS WILL SUITABLY MEET THE REQUIREMENTS OF THEIR INTENDED USE.

Omron further disclaims all warranties and responsibility of any type for claims or expenses based on infringement by the Products or otherwise of any intellectual property right. (c) Buyer Remedy. Omron's sole obligation hereunder shall be, at Omron's election, to (i) replace (in the form originally shipped with Buyer responsible for labor charges for removal or replacement thereof) the non-complying Product, (ii) repair the non-complying Product, or (iii) repay or credit Buyer an amount equal to the purchase price of the non-complying Product; provided that in no event shall Omron be responsible for warranty, repair, indemnity or any other claims or expenses regarding the Products unless Omron's analysis confirms that the Products were properly handled, stored, installed and maintained and not subject to contamination, abuse, misuse or inappropriate modification. Return of any Products by Buyer must be approved in writing by Omron before shipment. Omron Companies shall not be liable for the suitability or unsuitability or the results from the use of Products in combination with any electrical or electronic components, circuits, system assemblies or any other materials or substances or environments. Any advice, recommendations or information given orally or in writing, are not to be construed as an amendment or addition to the above warranty.

See <http://www.omron.com/global/> or contact your Omron representative for published information.

### Limitation on Liability: Etc.

OMRON COMPANIES SHALL NOT BE LIABLE FOR SPECIAL, INDIRECT, INCIDENTAL, OR CONSEQUENTIAL DAMAGES, LOSS OF PROFITS OR PRODUCTION OR COMMERCIAL LOSS IN ANY WAY CONNECTED WITH THE PRODUCTS, WHETHER SUCH CLAIM IS BASED IN CONTRACT, WARRANTY, NEGLIGENCE OR STRICT LIABILITY.

Further, in no event shall liability of Omron Companies exceed the individual price of the Product on which liability is asserted.

### Suitability of Use.

Omron Companies shall not be responsible for conformity with any standards, codes or regulations which apply to the combination of the Product in the Buyer's application or use of the Product. At Buyer's request, Omron will provide applicable third party certification documents identifying ratings and limitations of use which apply to the Product. This information by itself is not sufficient for a complete determination of the suitability of the Product in combination with the end product, machine, system, or other application or use. Buyer shall be solely responsible for determining appropriateness of the particular Product with respect to Buyer's application, product or system. Buyer shall take application responsibility in all cases.

NEVER USE THE PRODUCT FOR AN APPLICATION INVOLVING SERIOUS RISK TO LIFE OR PROPERTY OR IN LARGE QUANTITIES WITHOUT ENSURING THAT THE SYSTEM AS A WHOLE HAS BEEN DESIGNED TO ADDRESS THE RISKS, AND THAT THE OMRON PRODUCT(S) IS PROPERLY RATED AND INSTALLED FOR THE INTENDED USE WITHIN THE OVERALL EQUIPMENT OR SYSTEM.

### Programmable Products.

Omron Companies shall not be responsible for the user's programming of a programmable Product, or any consequence thereof.

### Performance Data.

Data presented in Omron Company websites, catalogs and other materials is provided as a guide for the user in determining suitability and does not constitute a warranty. It may represent the result of Omron's test conditions, and the user must correlate it to actual application requirements. Actual performance is subject to the Omron's Warranty and Limitations of Liability.

### Change in Specifications.

Product specifications and accessories may be changed at any time based on improvements and other reasons. It is our practice to change part numbers when published ratings or features are changed, or when significant construction changes are made. However, some specifications of the Product may be changed without any notice. When in doubt, special part numbers may be assigned to fix or establish key specifications for your application. Please consult with your Omron's representative at any time to confirm actual specifications of purchased Product.

### Errors and Omissions.

Information presented by Omron Companies has been checked and is believed to be accurate; however, no responsibility is assumed for clerical, typographical or proofreading errors or omissions.

2020.2

In the interest of product improvement, specifications are subject to change without notice.

**OMRON Corporation**  
Industrial Automation Company

<http://www.ia.omron.com/>

(c)Copyright OMRON Corporation 2020 All Right Reserved.



# SCATTERGOOD & JOHNSON LTD

ELECTRICAL ENGINEERING & FLUID CONTROL DISTRIBUTORS

Est.1899

At Scattergood & Johnson Ltd, we pride ourselves on being a technical distributor to specialist industries.

Working with a range of quality product suppliers across a number of specialist markets, we are not your average 'box shifter' - we are your technical and supply chain partner.

We fully support every product we sell - for free! Our internal team and external sales engineers can answer any product or application question, no matter the complexity.

Backing up this technical ability is a range of 50,000+ products available from stock for nationwide next day delivery (same day if required!), or you can collect what you need from any of our trade counters around the UK.

Select your specialist interest below to learn more about how we can help.



Online, In Branch and On the Road - Scattergood & Johnson Ltd, there when you need us.

# [www.scatts.co.uk](http://www.scatts.co.uk)