

NX-series Safety Control Units

NX-SL/SI/SO

CSM_NX-SL_SI_SO_E_4_9

Integration of Safety into Machine Automation Enables Simple, Flexible System Configuration.

- EN ISO13849-1 (PLe/Safety Category4), IEC 61508 (SIL3) certified.
- One connection using Safety over EtherCAT (FSoE) * protocol enables flexible configuration by mixing the Safety Units with standard NX I/O.
- Hardware and safety circuits can be configured using the Sysmac Studio (Ver. 1.07)



For the most recent information on models that have been certified for safety standards, refer to your OMRON website.

* Safety over EtherCAT (FSoE): The open protocol Safety over EtherCAT (abbreviated with FSoE "FailSafe over EtherCAT") defines a safety related communication layer for EtherCAT. Safety over EtherCAT meets the requirements of IEC 61508 SIL 3 and enables the transfer of safe and standard information on the same communication system without limitations with regard to transfer speed and cycle time.

Features

- Integrated safety into machine automation possible by connecting with the NX-series EtherCAT Coupler.
- The Safety CPU Unit controls up to 128 Safety I/O Units.
- 4 or 8 points per Safety Input Unit. The 4-point Safety Input Unit can be directly connected with OMRON Non-contact Switches and Singlebeam Sensors.
- 2 or 4 points per Safety Output Unit. The 2-point Safety Output Unit is characterized by large output breaking current of 2.0 A.
- The Safety Units can be freely allocated in any combination with standard NX I/O.
- Compliant with IEC61131-3
- Safety programs can be standardized and reused efficiently by using POU's for design and operation.

Sysmac is a trademark or registered trademark of OMRON Corporation in Japan and other countries for OMRON factory automation products. EtherCAT® is registered trademark and patented technology, licensed by Beckhoff Automation GmbH, Germany. Safety over EtherCAT® is registered trademark and patented technology, licensed by Beckhoff Automation GmbH, Germany. ODVA, CIP™, CompoNet™, DeviceNet™, EtherNet/IP™, and CIP Safety™ are trademarks of ODVA. Other company names and product names in this document are the trademarks or registered trademarks of their respective companies.

System Configuration

EtherCAT System

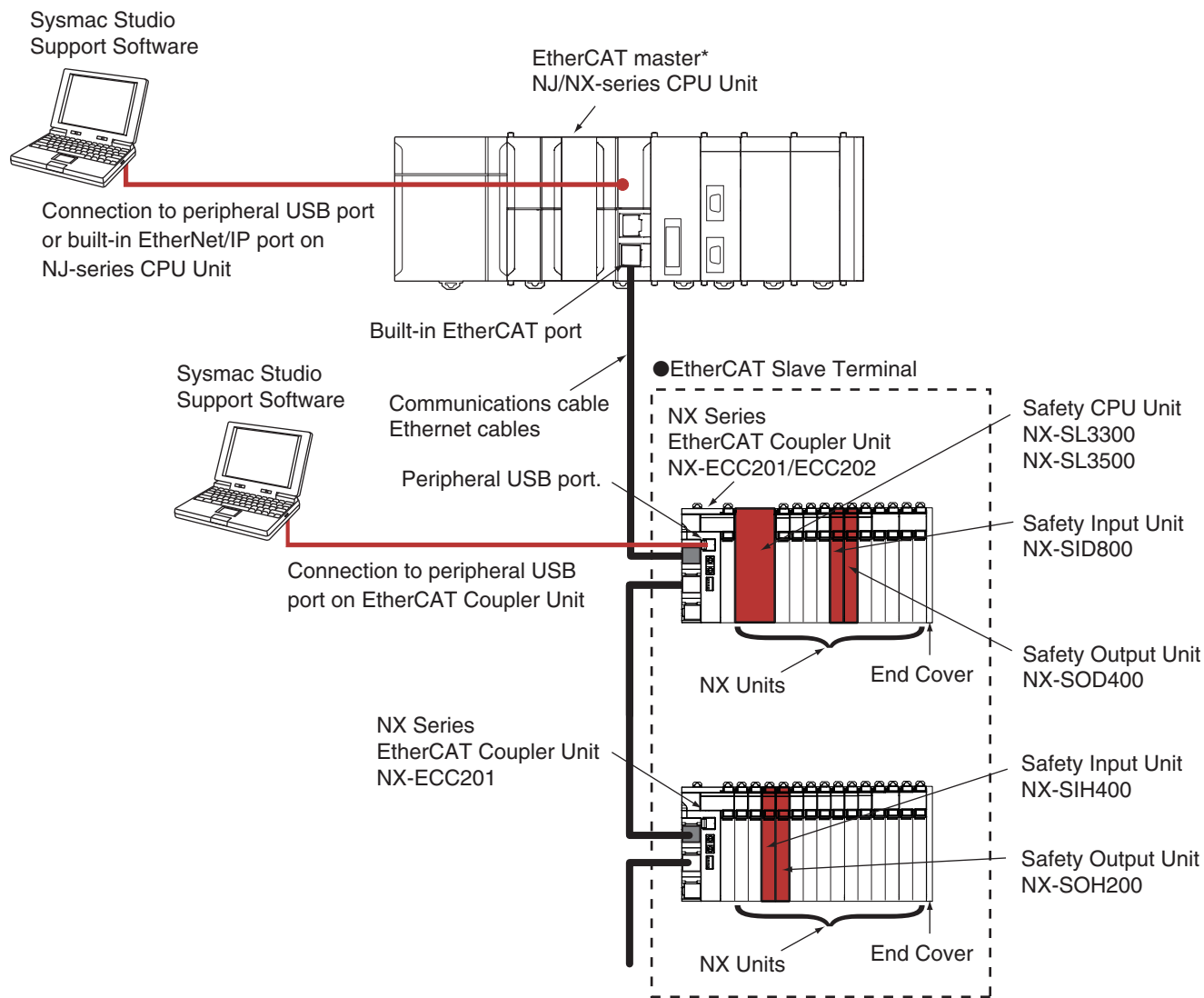

* OMRON CJ1W-NC□81/□82 Position Control Units cannot be connected to the EtherCAT Slave Terminal even though they support EtherCAT.

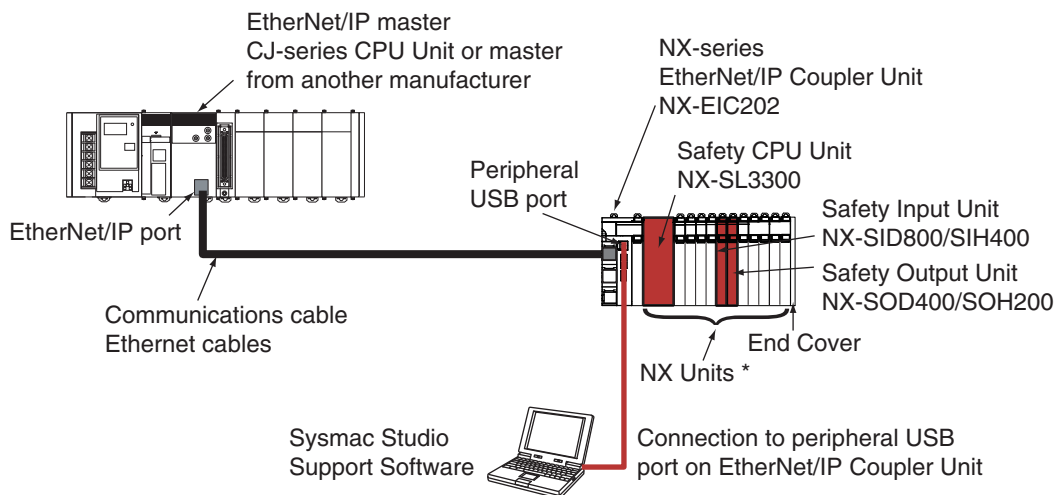

Stand-alone System



* Refer to *NX-series EtherNet/IP™ Coupler Unit Datasheet* for the NX Units that can be connected to the NX-series EtherNet/IP Coupler Unit.



Ordering Information

Safety CPU Unit

Unit type	Appearance	Specifications				Unit version	Model
		Maximum number of safety I/O points	Program capacity	Number of safety I/O connections	I/O refreshing method		
Safety CPU Unit (NX-SL3□□0)		256 points	512KB	32	Free-Run refreshing	Ver. 1.1	NX-SL3300
		1024 points	2048KB	128	Free-Run refreshing	Ver. 1.1	NX-SL3500

Note: Refer to the NX-CSG/SL5/SI/SO Datasheet (www.ia.omron.com/) for details of the NX-SL5□□□ Safety CPU Unit.

Safety Input Units



Unit type	Appearance	Specifications							Unit version	Model
		Number of safety input points	Number of test output points	Internal I/O common	Rated input voltage	OMRON special safety input devices	Number of safety slave connections	I/O refreshing method		
Safety Input Units		4 points	2 points	Sinking inputs (PNP)	24 VDC	Can be connected. *	1	Free-Run refreshing	Ver. 1.1	NX-SIH400
		8 points	2 points	Sinking inputs (PNP)	24 VDC	Cannot be connected.	1	Free-Run refreshing	Ver. 1.0	NX-SID800

* The following OMRON special safety input devices can be connected directly without a special controller.

For detail of connectable OMRON special safety input devices, refer to NX-series Safety Control Units User's Manual (Cat.No.Z930).

Type	Model and corresponding PL and safety category
OMRON Single-beam Safety Sensors	E3ZS and E3FS
OMRON Non-contact Door Switches	D40Z D40A
OMRON Safety Mats	UM, UMA
OMRON Safety Edges	SGE (4-wire connection)

Safety Output Units

Unit type	Appearance	Specifications						Unit version	Model
		Number of safety output points	Internal I/O common	Maximum load current	Rated voltage	Number of safety slave connections	I/O refreshing method		
Safety Output Units		2 points	Sourcing outputs (PNP)	2.0 A/point, 4.0 A/Unit at 40°C, and 2.5 A/Unit at 55°C The maximum load current depends on the installation orientation and ambient temperature.	24 VDC	1	Free-Run refreshing	Ver. 1.0	NX-SOH200
		4 points	Sourcing outputs (PNP)	0.5 A/point and 2.0 A/Unit	24 VDC	1	Free-Run refreshing	Ver. 1.0	NX-SOD400

Option



Product Name	Specification	Model			
Unit/Terminal Block Coding Pins	For 10 Units (Terminal Block: 30 pins, Unit: 30 pins)	NX-AUX02			
Product name	Specification				Model
	No. of terminals	Terminal number indications	Ground terminal mark	Terminal current capacity	
Terminal Block	8	A/B	None	10A	NX-TBA082
	16	A/B	None	10A	NX-TBA162

Accessories

Not included.

Configuration Devices

NX-series Communications Coupler Units

Product name	Appearance	Supported communications protocol	NX Unit power consumption	Maximum I/O power supply current	Model
EtherCAT Coupler Unit *1		Communications cycle in DC Mode *2 250 to 4,000 μs	1.45 W or lower	4A	NX-EEC201
		Communications cycle in DC Mode *2 125 to 10,000 μs	1.25 W or lower	10A	NX-EEC202
					NX-EEC203
EtherNet/IP Coupler Unit *1		EtherNet/IP	1.60 W or lower	10A	NX-EIC202

Note: For details, refer to your local OMRON website.

*1 One End Cover NX-END01 is provided with the NX-series Communications Coupler Units.

*2 This depends on the specifications of the EtherCAT master. For example, the values are as follows when the EtherCAT Coupler Unit is connected to the built-in EtherCAT port on an NJ5-series CPU Unit: 500 μs, 1,000 μs, 2,000 μs, and 4,000 μs. Refer to the NJ/NX-series CPU Unit Built-in EtherCAT Port User's Manual (Cat. No. W505) for the specifications of the built-in EtherCAT ports on NJ/NX-series CPU Units. This also depends on the unit configuration.

Automation Software Sysmac Studio

Please purchase a DVD and required number of licenses the first time you purchase the Sysmac Studio. DVDs and licenses are available individually. Each model of licenses does not include any DVD.

Product name	Specifications			Model
		Number of licenses	Media	
Sysmac Studio NX-I/O Edition Ver.1.□□ *1	Sysmac Studio NX-I/O Edition is a limited license that provides selected functions required for EtherNet/IP Coupler settings. * Because this product is a license only, you need the Sysmac Studio Standard Edition DVD media to install it.	1 license	---	SYSMAC-NE001L
Sysmac Studio Safety Edition Ver.1.□□ *2	Sysmac Studio Safety Edition is a license including necessary setting functions for the safety control system. * Because this product is a license only, you need the Sysmac Studio Standard Edition DVD media to install it.	1 license	---	SYSMAC-FE001L
Sysmac Studio Standard Edition Ver.1.□□ *3*4	The Sysmac Studio is the software that provides an integrated environment for setting, programming, debugging and maintenance of machine automation controllers including the NJ/NX-series CPU Units, NY-series Industrial PC, EtherCAT Slave, and the HMI.	1 license *5	---	SYSMAC-SE201L
	Sysmac Studio runs on the following OS. Windows 7(32-bit/64-bit version)/8(32-bit/64-bit version)/8.1(32-bit/64-bit version)/10(32-bit/64-bit version) * Refer to your OMRON website for details such as supported models and functions.	(Media only)	DVD	SYSMAC-SE200D

*1 With the NX-I/O Edition, you can use only the setup functions for EtherNet/IP Coupler.

*2 Safety Edition can be used with Communication Control Unit and EtherNet/IP Coupler Unit.

*3 The Sysmac Studio Standard Edition with license(s) (SYSMAC-SE□□□L) provides functions of the NX-I/O Edition (SYSMAC-NE001L).

*4 With the Sysmac Studio Standard Edition with license(s) (SYSMAC-SE□□□L) version 1.10 or higher, you can use the setup functions for the EtherNet/IP Coupler.

*5 Multi licenses are available for the Sysmac Studio (3, 10, 30, or 50 licenses).

Specifications

Regulations and Standards

NX-series Safety Control Units NX-SL3/SI/SO

Certification body	Standards
TÜV Rheinland *	<ul style="list-style-type: none"> • EN ISO 13849-1 • EN ISO 13849-2 • IEC 61508 parts 1-7 • IEC/EN 62061 • IEC/EN 61131-2 • IEC 61326-3-1
UL	<ul style="list-style-type: none"> • NRAG (UL 508 and ANSI/ISA 12.12.01) • NRAG7 (CSA C22.2 No. 142 and CSA C22.2 No. 213)

* The FSoE was certified for applications in which OMRON FSoE devices are connected to each other.

The NX-series Safety Control Units allow you to build a safety control system that meets the following standards.

- Requirements for SIL 3 (Safety Integrity Level 3) in IEC 61508, EN 62061, (Functional Safety of Electrical/Electronic/Programmable Electronic Safety-related Systems)
- Requirements for PLe (Performance Level e) and for safety category 4 in EN ISO13849-1



The NX-series Safety Control Units are also registered for RCM, EAC, and KC compliance.

General Specifications

Item	Specification	
Enclosure	Mounted in a panel (open)	
Grounding method	Ground to 100 Ω or less.	
Operating environment	Ambient operating temperature	0 to 55°C (The upper limit of the ambient operating temperature is restricted by the installation orientation.)
	Ambient operating humidity	10% to 95% (with no condensation or icing)
	Atmosphere	Must be free from corrosive gases.
	Ambient storage temperature	-25 to 70°C (with no condensation or icing)
	Altitude	2,000 m max.
	Pollution degree	2 or less.
	Noise immunity	Conforms to IEC 61131-2. 2 kV on power supply line (Conforms to IEC 61000-4-4.)
	Insulation class	Class III (SELV)
	Overvoltage category	II
	EMC immunity level	Zone B
	Vibration resistance	Conforms to IEC 60068-2-6. 5 to 8.4 Hz with 3.5-mm amplitude, 8.4 to 150 Hz, acceleration of 9.8 m/s ² , 100 minutes each in X, Y, and Z directions (10 sweeps of 10 min each = 100 min total)
	Shock resistance	Conforms to IEC 60068-2-27. 147 m/s ² , 3 times each in X, Y, and Z directions
	Insulation resistance	20 MΩ between isolated circuits (at 100 VDC)
	Dielectric strength	510 VAC for 1 min between isolated circuits, leakage current: 5 mA max.
Installation method	DIN Track (IEC 60715 TH35-7.5/TH35-15)	

Specifications of Individual Units



Safety CPU Unit NX-SL3300/SL3500

Unit name	Safety CPU Unit	
Model	NX-SL3300	NX-SL3500
Maximum number of safety I/O points	256 points	1024 points
Program capacity	512 KB	2048 KB
Number of safety master connections	32	128
I/O refreshing method	Free-Run refreshing	
External connection terminals	None	
Indicators	[FS] LED, [VALID] LED, [DEBUG] LED, [TS] LED, [RUN] LED 	[FS] LED, [VALID] LED, [DEBUG] LED, [TS] LED, [RUN] LED 
Dimensions	30 × 100 × 71 mm (W × H × D)	
I/O power supply method	Not supplied.	
Current capacity of I/O power supply terminals	No I/O power supply terminals	
NX Unit power consumption *1	<ul style="list-style-type: none"> Connected to a CPU Unit 1.25 W max. Connected to a Communications Coupler Unit 0.90 W max. 	
Current consumption from I/O power supply	No consumption	
Weight	75 g max.	
Installation orientation and restrictions	Installation orientation: <ul style="list-style-type: none"> Connected to a CPU Unit *2 Possible in the upright installation orientation. Connected to a Communications Coupler Unit Six possible orientations. Restriction: None	

*1 The cable length for the Units that supply power to the corresponding Unit must be up to 20 m.

*2 Only NX102 CPU Units can be connected. NX1P2 CPU Units cannot be connected.

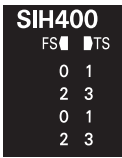
Safety Input Units NX-SIH400/SID800

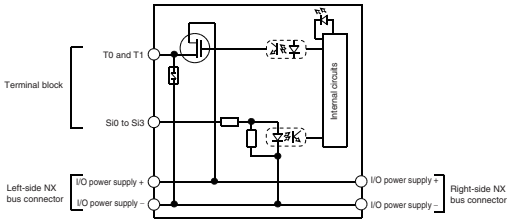
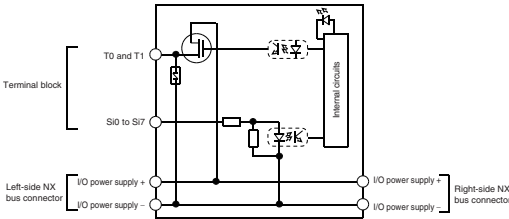
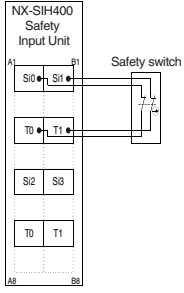
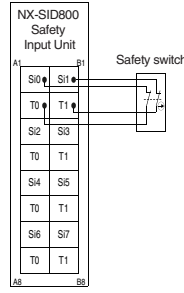
Unit name	Safety Input Unit	
Model	NX-SIH400	NX-SID800
Number of safety input points	4 points	8 points
Number of test output points	2 points	2 points
Internal I/O common	PNP (sinking inputs)	
Rated input voltage	24 VDC (20.4 to 28.8 VDC)	
OMRON special safety input devices	Can be connected.	Cannot be connected.
Number of safety slave connections	1	
I/O refreshing method	Free-Run refreshing	
External connection terminals	Screwless clamping terminal block (8 terminals)	Screwless clamping terminal block (16 terminals)
Indicators	[TS] LED, [FS] LED, [IN] LED, [IN ERR] LED	[TS] LED, [FS] LED, [IN] LED, [IN ERR] LED
		
Safety input current	4.5 mA typical	3.0 mA typical
Safety input ON voltage	11 VDC min.	15 VDC min.
Safety input OFF voltage/OFF current	5 VDC max., 1 mA max.	
Test output type	Sourcing outputs (PNP)	
Test output load current	25 mA max.	50 mA max.
Test output residual voltage	1.2 V max. (Between IOV and all output terminals)	
Test output leakage current	0.1 mA max.	
Dimensions	12 × 100 × 71 mm (W × H × D)	
Isolation method	Photocoupler isolation	
Insulation resistance	20 MΩ min. between isolated circuits (at 100 VDC)	
Dielectric strength	510 VAC for 1 min between isolated circuits, leakage current: 5 mA max.	
I/O power supply method	Power supplied from the NX bus	
Current capacity of I/O power supply terminals	No applicable terminals.	
NX Unit power consumption	<ul style="list-style-type: none"> Connected to a CPU Unit or a Communication Control Unit 1.10 W max. Connected to a Communications Coupler Unit 0.70 W max. 	<ul style="list-style-type: none"> Connected to a CPU Unit or a Communication Control Unit 1.10 W max. Connected to a Communications Coupler Unit 0.75 W max.
Current consumption from I/O power supply	20 mA max.	
Weight	70 g max.	
Circuit layout		
Terminal connection diagram	<p>Si0 to Si3: Safety input terminals T0 and T1: Test output terminals</p>  <p>Refer to User's manual (Cat.No.Z930) for details.</p>	<p>Si0 to Si7: Safety input terminals T0 and T1: Test output terminals</p>  <p>Refer to User's manual (Cat.No.Z930) for details.</p>
Installation orientation and restrictions	<p>Installation orientation:</p> <ul style="list-style-type: none"> Connected to a CPU Unit or a Communication Control Unit Possible in the upright installation orientation. Connected to a Communications Coupler Unit 6 possible orientations. <p>Restrictions: Maximum ambient temperature is 50°C for any orientation other than upright installation.</p>	
Protective functions	Overvoltage protection circuit and short detection (test outputs)	

Safety Output Units NX-SOH200/SOD400

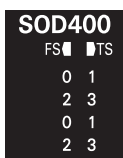
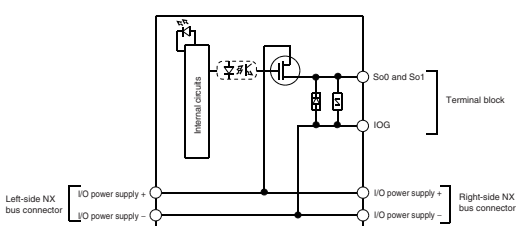
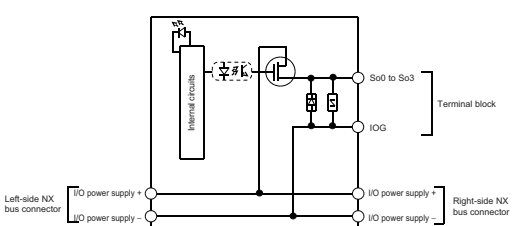
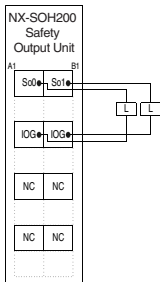
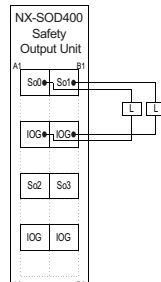
Unit name	Safety Output Unit	
Model	NX-SOH200	NX-SOD400
Number of safety output points	2 points	4 points
Internal I/O common	PNP (sourcing outputs)	
Maximum load current	2.0 A/point 4.0 A/Unit at 40°C 2.5 A/Unit at 55°C The maximum load current depends on the installation orientation and ambient temperature	0.5 A/point and 2.0 A/Unit
Rated voltage	24 VDC (20.4 to 28.8 VDC)	
Number of safety slave connections	1	
I/O refreshing method	Free-Run refreshing	
External connection terminals	Screwless clamping terminal block (8 terminals)	
Indicators	<p>[TS] LED, [FS] LED, [OUT] LED, [OUT ERR] LED</p> 	<p>[TS] LED, [FS] LED, [OUT] LED, [OUT ERR] LED</p> 
Safety output ON residual voltage	1.2 V max. (Between IOV and all output terminals)	
Safety output OFF residual voltage	2 V max. (Between IOG and all output terminals)	
Safety output leakage current	0.1 mA max.	
Dimensions	12 × 100 × 71 mm (W × H × D)	
Isolation method	Photocoupler isolation	
Insulation resistance	20 MΩ min. between isolated circuits (at 100 VDC)	
Dielectric strength	510 VAC for 1 min between isolated circuits, leakage current: 5 mA max.	
I/O power supply method	Power supplied from the NX bus	
Current capacity of I/O power supply terminals	IOG: 2 A max./terminal	IOG (A3 and B3): 2 A max./terminal IOG (A7 and B7): 0.5 A max./terminal
NX Unit power consumption	<ul style="list-style-type: none"> Connected to a CPU Unit or a Communication Control Unit 1.05 W max. Connected to a Communications Coupler Unit 0.70 W max. 	<ul style="list-style-type: none"> Connected to a CPU Unit or a Communication Control Unit 1.10 W max. Connected to a Communications Coupler Unit 0.75 W max.
Current consumption from I/O power supply	40 mA max.	60 mA max.
Weight	65 g max.	
Circuit layout		
Terminal connection diagram	<p>So0 and So1: Safety output terminals IOG: I/O power supply 0 V</p>  <p>Refer to User's manual (Cat.No.Z930) for details.</p>	<p>So0 to So3: Safety output terminals IOG: I/O power supply 0 V</p>  <p>Refer to User's manual (Cat.No.Z930) for details.</p>

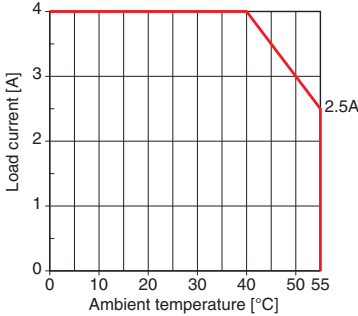
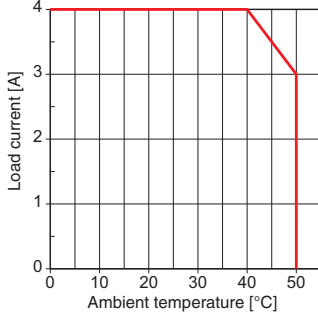
Unit name	Safety Output Unit	
Model	NX- SOH200	NX-SOD400
Installation orientation and restrictions	<p>Installation orientation:</p> <ul style="list-style-type: none"> • Connected to a CPU Unit or a Communication Control Unit Possible in the upright installation orientation. • Connected to a Communications Coupler Unit 6 possible orientations <p>Restrictions: For upright installation, the ambient temperature is restricted as shown below depending on the total Unit load current.</p>  <p>For all installation orientations other than upright installation, the ambient temperature is restricted as shown below according to the total Unit load current.</p> 	
Protective functions	Overvoltage protection circuit and short detection	

Function Specifications

	Item	Function	
Setting Parameters	Safety I/O Settings	You make a setting for safety process data communications and connection with safety I/O devices.	
	Safety Process Data Communications Settings	You select Safety I/O Units to perform safety process data communications (FSOE communications) and make necessary settings.	
	Safety Device Allocation Settings	You set the connection between Safety I/O Units and safety devices.	
	EtherNet/IP Safety Connection Settings #1	You can register target devices of EtherNet/IP Safety network and configure the connection settings.	
	Standard I/O Settings	Exposed Variable Settings	You set whether to expose global variables of the Safety CPU Unit. The values of exposed variables can be referenced from NJ/NX-series CPU Units and NY-series Industrial PCs.
		Standard Process Data Communications #2	You set the devices and ports of the Standard I/O Units for the exposed variables of the Safety CPU Unit.
	Safety Task Settings		You define the execution cycle and timing of the safety task and programs to be executed in the task.
		Assigning Programs	You assign safety programs to execute to the task.
I/O Map Settings		The ports of Safety I/O Units used in safety process data communications are displayed. You assign device variables used in safety programs to the I/O ports.	
Creating Safety Programs	Instruction List (Toolbox)	A hierarchy of the functions and function blocks that you can use is displayed in the Toolbox. You can drag the required functions and function blocks onto the FBD editor to insert it to a safety program.	
	FBD Programming		You connect variables, functions, and function blocks with connecting lines to build networks. The FBD editor is used to enter them.
		Adding FBD Networks	You create FBD networks on the FBD editor to create algorithms.
		Inserting and Deleting Functions and Function blocks	You insert and delete functions and function blocks on the FBD editor.
		Entry Assistance	When you enter functions, function blocks, or parameters, each character that you enter from the keyboard narrows the list of candidates that is displayed for selection.
		Commenting Out FBD Networks	You can comment out each FBD network. When a network is commented out, it is no longer executed.
	Converting Programs into Function Blocks #1	You can convert the safety program into user-defined function block.	
	Automatic Programming #1	A safety programs can be automatically generated from input and output signals and expected values of the program.	
	Creating Variables	You create variables used in safety programs in the global or local variable table.	
	User-defined Function Blocks		You create user-defined function blocks.
		Help Reference #3	You can display the user-defined function block help with the popup menu or shortcut key.
	Export/Import		POUs can be exported and imported.
		Programs #4	You can export/import POU's.
		User-defined Function Blocks #3	You can export/import user-defined function blocks.
Searching and Replacing		You can search for and replace strings in the variable tables, programs, and function blocks of a Safety CPU Unit.	
Debugging	Monitoring	Variables are monitored during safety program execution. You can monitor the present values of device variables assigned to Safety I/O Units and user-defined variables. The values can be monitored on the FBD editor or Watch Tab Page.	
	Changing the Present Values of Variables	You can change the present values of user-defined variables and device variables as required. You can do this on the FBD editor or Watch Tab Page.	
	Forced Refreshing		The inputs from external devices and outputs to external devices are refreshed with a specified value on the Sysmac Studio. The specified value is retained even if the value of the variable is overwritten from the user program.
			You can use forced refreshing on the FBD editor or Watch Tab Page.
	Offline Debugging #5		You can check if the control program logic works as designed in advance using a special debugging function for the Simulator without connecting online with the Safety CPU Unit.
		Initial Value Settings #6	You can set the initial values of variables when you start execution of simulation.
		Feedback Settings #6	You can set input status that is linked to changes in output status when simulator is running.
Simple Automatic Test #7	You can check that expected values of the outputs to the inputs of the program are designed as intended using the Simulator functions of the Safety CPU Unit.		
User Memory Usage Monitor #6		The memory usage of the safety control system and usage of safety network such as I/O data size are displayed.	
Debugging	Online Functional Test #1	This function helps you to check the safety functional operation of the safety system. You can produce output device operation relative to the input and check whether the system operates as expected. It is possible to output the check results.	
Safety	Safety Validation	You append the "safety-validated" information to a safety program when you can ensure safety of the program after you complete debugging.	
	Changing Operating Mode	There are four operating modes; PROGRAM mode, DEBUG mode (STOPPED), DEBUG mode (RUN), and RUN mode. The RUN mode can be selected only for the validated safety programs.	
Maintenance	Generating Safety Data Logging Settings File #1	Settings to use the safety data logging function can be generated as a file.	
	Generating Safety Unit Restore File #1	A file of safety program and settings to be transferred to the Safety CPU Unit using an SD memory card is generated for Safety Unit Restore function.	

Item		Function
Security Measures	Prevention of Incorrect Connections	Setting the Node Name
	Prevention of Incorrect Operation	Safety Password
	Prevention of Theft of Assets	Data Protection (Programs) *4
		Data Protection (User-defined Function Blocks) *3
		You set a unique name for each Safety CPU Unit to confirm that you operate the correct Safety CPU Unit.
		You can prevent unauthorized access to safety functions of Safety CPU Units by setting a safety password for online operations that affect the safety functions.
		You can set passwords for individual programs to prohibit displaying or changing them.
		You can set passwords for individual user-defined function blocks to prohibit displaying or changing them.

Note: Supported only by the Sysmac Studio version 1.07 or higher.

*1. Supported only by the Sysmac Studio version 1.24 or higher.

*2. Supported if the EtherNet/IP Coupler is selected with Sysmac Studio version 1.11 or higher.

*3. Supported only by the Sysmac Studio version 1.12 or higher.

*4. Supported only by the Sysmac Studio version 1.17 or higher.

*5. Supported only by the Sysmac Studio version 1.08 or higher.

*6. Supported only by the Sysmac Studio version 1.10 or higher.

*7. Supported only by the Sysmac Studio version 1.15 or higher.

Refer to the *SYSMAC-SE□□□□ Datasheet* (www.ia.omron.com/) for function specifications of the Safety Control Unit.

Version Information

- Relationship between Unit Versions and Sysmac Studio Versions

EtherCAT Slave Terminal and EtherNet/IP Slave Terminal

- This configuration is used to connect the Safety Control Unit to the EtherCAT Coupler Units, and the EtherCAT Slave Terminal to the built-in EtherCAT master of the CPU Unit via EtherCAT.
- This configuration is used to connect the Safety Control Units to the EtherNet/IP Coupler Units.

NX Unit		Corresponding version *1				
Model number	Unit version	EtherCAT Coupler Unit NX-ECC20□	NJ/NX-series CPU Units *2	Sysmac Studio	EtherNet/IP Coupler Unit (NX-EIC202)	Sysmac Studio
NX-SL3300	1.0	1.1 or later	1.06 or later	1.07 or later	---	---
	1.1			1.10 or later	1.0 or later	1.10 or later
NX-SL3500	1.0	1.2 or later	1.07 or later	1.08 or later	---	---
	1.1			1.10 or later	---	---
NX-SIH400	1.0	1.1 or later	1.06 or later	1.07 or later	---	---
	1.1			1.10 or later	1.0 or later	1.10 or later
NX-SID800	1.0			1.07 or later		
NX-SOH200						
NX-SOD400						

*1 Some Units do not have all of the versions given in the above table.

If a Unit does not have the specified version, support is provided by the oldest available version after the specified version.

Refer to the user's manuals for the specific Units for the relation between models and versions.

*2 These Units cannot be mounted to Machine Automation Controllers with NX1P CPU Units. Mount and use an EtherCAT Coupler Unit instead.

CPU Rack

- This configuration is used to connect the Safety Control Units to the CPU Units.

Safety Control Unit model and version		NX bus master: CPU Unit	
Model	Unit version	NX102 CPU Units	Sysmac Studio
NX-SL3300	Ver. 1.0	Ver. 1.30	Ver. 1.22
	Ver. 1.1		
NX-SL3500	Ver. 1.0	Ver. 1.31	Ver. 1.24
	Ver. 1.1		
NX-SL5500	Ver. 1.3	---	---
NX-SL5700	Ver. 1.2	Ver. 1.31	Ver. 1.24
	Ver. 1.3		
NX-SIH400	Ver. 1.0	Ver. 1.30	Ver. 1.22
	Ver. 1.1		
NX-SID800	Ver. 1.0		
NX-SOH200			
NX-SOD400			

External Interface

Safety CPU Unit

NX-SL3300/SL3500

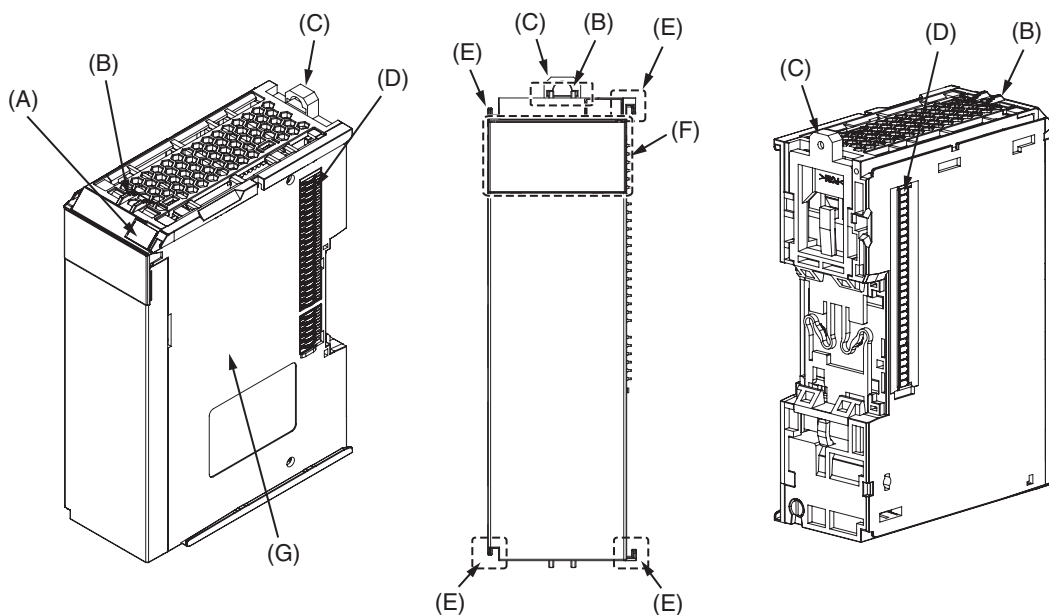

Letter	Item	Specification
(A)	Marker attachment locations	The locations where markers are attached. The markers made by OMRON are installed for the factory setting. Commercially available markers can also be installed.
(B)	Protrusions for removing the Unit	The protrusions to hold when removing the Unit.
(C)	DIN Track mounting hooks	These hooks are used to mount the NX Unit to a DIN Track.
(D)	NX bus connector	This is the NX-series bus connector. It is used to connect an NX-series Safety I/O Unit or other NX Unit.
(E)	Unit hookup guides	These guides are used to connect two Units.
(F)	Indicators	The indicators show the current operating status of the NX Unit or signal I/O status.
(G)	Unit specifications	The specifications of the NX Unit are given here.

Safety Input Unit NX-SIH400/SID800
Safety Output Unit NX-SOH200/SOD400

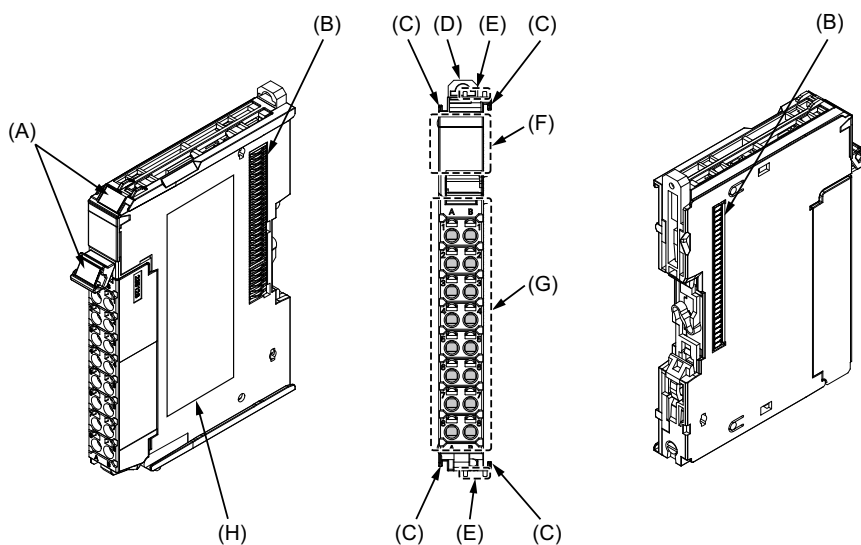

Letter	Item	Specification
(A)	Marker attachment locations	The locations where markers are attached. The markers made by OMRON are installed for the factory setting. Commercially available markers can also be installed.
(B)	NX bus connector	This is the NX-series bus connector. Connect this connector to another Unit, such as the NX-series Safety CPU Unit or a Safety I/O Unit.
(C)	Unit hookup guides	These guides are used to connect two Units.
(D)	DIN Track mounting hooks	These hooks are used to mount the NX Unit to a DIN Track.
(E)	Protrusions for removing the Unit	The protrusions to hold when removing the Unit.
(F)	Indicators	The indicators show the current operating status of the NX Unit or signal I/O status.
(G)	Terminal block	The terminal block is used to connect to external devices. It connects the safety outputs. The number of terminals depends on the NX Unit.
(H)	Unit specifications	The specifications of the NX Unit are given here.

Terminal Blocks

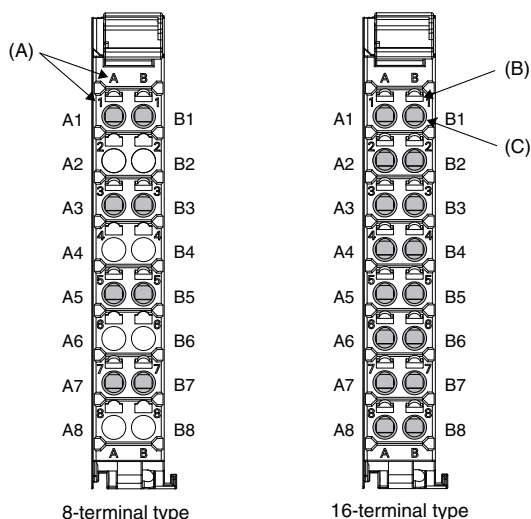

Letter	Item	Specification
(A)	Terminal number indications	The terminal numbers are given by column letters A and B, and row numbers 1 to 8. The combination of the column and row gives the terminal numbers from A1 to A8 and B1 to B8. The terminal number indicators are the same regardless of the number of terminals on the terminal block, as shown above.
(B)	Release holes	Insert a flat-blade screwdriver into these holes to connect and remove the wires.
(C)	Terminal holes	The wires are inserted into these holes.

Applicable Terminal Blocks for Each Unit Model

Unit model number	Terminal Blocks				
	Model	No. of terminals	Terminal number indications	Ground terminal mark	Terminal current capacity
NX-SIH400	NX-TBA082	8	A/B	None	10A
NX-SID800	NX-TBA162	16	A/B	None	10A
NX-SOH200	NX-TBA082	8	A/B	None	10A
NX-SOD400	NX-TBA082	8	A/B	None	10A

Applicable Wires

Using Ferrules

If you use ferrules, attach the twisted wires to them.

Observe the application instructions for your ferrules for the wire stripping length when attaching ferrules.

Always use plated one-pin ferrules. Do not use unplated ferrules or two-pin ferrules.

The applicable ferrules, wires, and crimping tool are given in the following table.

Terminal types	Manufacturer	Ferrule model number	Applicable wire (mm ² (AWG))	Crimping tool
Terminals other than ground terminals	Phoenix Contact	AI0,34-8	0.34 (#22)	Phoenix Contact (The figure in parentheses is the applicable wire size.) CRIMPFOX 6 (0.25 to 6 mm ² , AWG24 to 10)
		AI0,5-8	0.5 (#20)	
		AI0,5-10		
		AI0,75-8	0.75 (#18)	
		AI0,75-10		
		AI1,0-8	1.0 (#18)	
		AI1,0-10		
		AI1,5-8	1.5 (#16)	
Ground terminals	Phoenix Contact	AI1,5-10		
		AI2,5-10	2.0 *	
Terminals other than ground terminals	Weidmuller	H0.14/12	0.14 (#26)	Weidmuller (The figure in parentheses is the applicable wire size.) PZ6 Roto (0.14 to 6 mm ² , AWG 26 to 10)
		H0.25/12	0.25 (#24)	
		H0.34/12	0.34 (#22)	
		H0.5/14	0.5 (#20)	
		H0.5/16		
		H0.75/14	0.75 (#18)	
		H0.75/16		
		H1.0/14	1.0 (#18)	
		H1.0/16		
		H1.5/14	1.5 (#16)	
		H1.5/16		

* Some AWG 14 wires exceed 2.0 mm² and cannot be used in the screwless clamping terminal block.

When you use any ferrules other than those in the above table, crimp them to the twisted wires so that the following processed dimensions are achieved.

Finished Dimensions of Ferrules

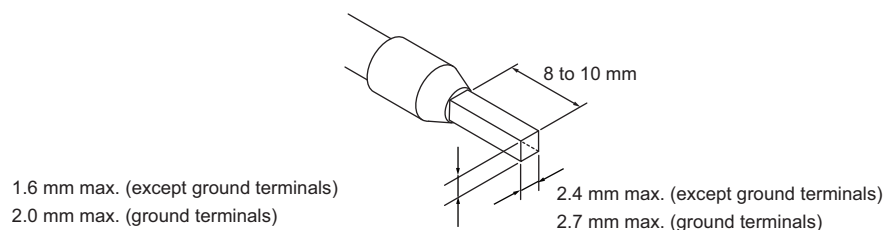

Using Twisted Wires/Solid Wires

If you use the twisted wires or the solid wires, use the following table to determine the correct wire specifications.

Terminals		Wire type				Wire size	Conductor length (stripping length)
		Twisted wires		Solid wire			
Classification	Current capacity	Plated	Unplated	Plated	Unplated		
All terminals except ground terminals	2 A max.		Possible	Possible	Possible	0.08 to 1.5 mm ² AWG28 to 16	8 to 10 mm
	Greater than 2 A and 4 A or less	Possible	Not Possible	Possible *1	Not Possible		
	Greater than 4 A	Possible *1	Possible	Not Possible	Not Possible		
Ground terminals	---	Possible	Possible	Possible *2	Possible *2	2.0 mm ²	9 to 10 mm

*1 Secure wires to the screwless clamping terminal block. Refer to the *Securing Wires* in the USER'S MANUAL for how to secure wires.

*2 With the NX-TB□□□1 Terminal Block, use twisted wires to connect the ground terminal. Do not use a solid wire.

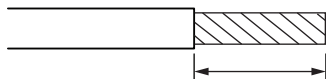

Conductor length (stripping length)

<Additional Information> If more than 2 A will flow on the wires, use plated wires or use ferrules.

Dimensions

(Unit/mm)

Safety CPU Unit NX-SL3300/SL3500

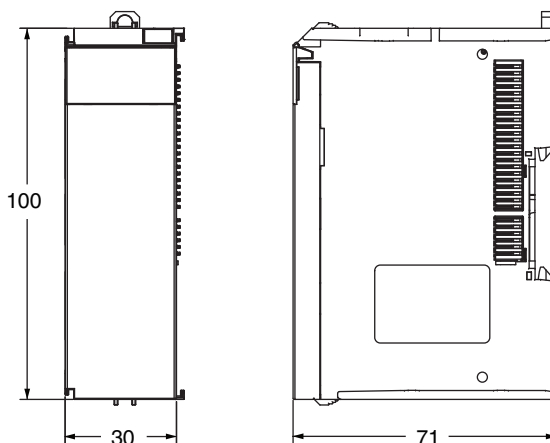

Safety Input Units NX-SIH400/SID800 Safety Output Units NX-SOH200/SOD400

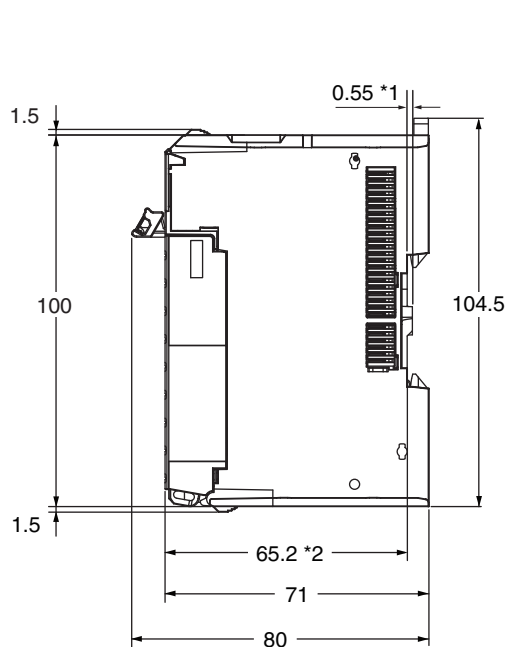

*1 The dimension is 1.35 mm for Units with lot numbers through December 2014.

*2 The dimension from the attachment surface of the DIN Track to the front surface of the Safety I/O Unit.

Related Manuals

Cat. No.	Model number	Manual name	Application	Description
Z930	NX-SL□□□□ NX-SI□□□□ NX-SO□□□□	NX-series Safety Control Unit User's Manual	Learning how to use NX-series Safety Control Units.	Describes the hardware, setup methods, and functions of the NX-series Safety Control Units.
Z931	NX-SL□□□□	NX-series Safety Control Unit Instructions Reference Manual	Learning about the specifications of instructions for the Safety CPU Unit.	Describes the instructions for the Safety CPU Unit. When programming, use this manual together with the <i>NX-series Safety Control Units User's Manual</i> (Cat. No. Z930).
W504	SYSMAC-SE2□□□	Sysmac Studio Version 1 Operation Manual	Learning about the operating procedures and functions of the Sysmac Studio.	Describes the operating procedures of the Sysmac Studio.
W519	NX-ECC□□□	NX-series EtherCAT® Coupler Unit User's Manual	Learning how to use the NX-series EtherCAT Coupler Unit and EtherCAT Slave Terminals.	The following items are described: the overall system and configuration methods of an EtherCAT Slave Terminal (which consists of an NX-series EtherCAT Coupler Unit and NX Units), and information on hardware, setup, and functions to set up, control, and monitor NX Units through EtherCAT.
W536	NX-EIC□□□	NX-series Ether-Net/IP™ Coupler Unit User's Manual	NX-EIC□□□ Learning how to use an NX-series EtherNet/IP Coupler Unit and EtherNet/IP Slave Terminals	The following items are described: the overall system and configuration methods of an EtherNet/IP Slave Terminal (which consists of an NX-series EtherNet/IP Coupler Unit and NX Units), and information on hardware, setup, and functions to set up, control, and monitor NX Units through EtherNet/IP.

Terms and Conditions Agreement

Read and understand this catalog.

Please read and understand this catalog before purchasing the products. Please consult your OMRON representative if you have any questions or comments.

Warranties.

(a) Exclusive Warranty. Omron's exclusive warranty is that the Products will be free from defects in materials and workmanship for a period of twelve months from the date of sale by Omron (or such other period expressed in writing by Omron). Omron disclaims all other warranties, express or implied.

(b) Limitations. OMRON MAKES NO WARRANTY OR REPRESENTATION, EXPRESS OR IMPLIED, ABOUT NON-INFRINGEMENT, MERCHANTABILITY OR FITNESS FOR A PARTICULAR PURPOSE OF THE PRODUCTS. BUYER ACKNOWLEDGES THAT IT ALONE HAS DETERMINED THAT THE PRODUCTS WILL SUITABLY MEET THE REQUIREMENTS OF THEIR INTENDED USE.

Omron further disclaims all warranties and responsibility of any type for claims or expenses based on infringement by the Products or otherwise of any intellectual property right. (c) Buyer Remedy. Omron's sole obligation hereunder shall be, at Omron's election, to (i) replace (in the form originally shipped with Buyer responsible for labor charges for removal or replacement thereof) the non-complying Product, (ii) repair the non-complying Product, or (iii) repay or credit Buyer an amount equal to the purchase price of the non-complying Product; provided that in no event shall Omron be responsible for warranty, repair, indemnity or any other claims or expenses regarding the Products unless Omron's analysis confirms that the Products were properly handled, stored, installed and maintained and not subject to contamination, abuse, misuse or inappropriate modification. Return of any Products by Buyer must be approved in writing by Omron before shipment. Omron Companies shall not be liable for the suitability or unsuitability or the results from the use of Products in combination with any electrical or electronic components, circuits, system assemblies or any other materials or substances or environments. Any advice, recommendations or information given orally or in writing, are not to be construed as an amendment or addition to the above warranty.

See <http://www.omron.com/global/> or contact your Omron representative for published information.

Limitation on Liability: Etc.

OMRON COMPANIES SHALL NOT BE LIABLE FOR SPECIAL, INDIRECT, INCIDENTAL, OR CONSEQUENTIAL DAMAGES, LOSS OF PROFITS OR PRODUCTION OR COMMERCIAL LOSS IN ANY WAY CONNECTED WITH THE PRODUCTS, WHETHER SUCH CLAIM IS BASED IN CONTRACT, WARRANTY, NEGLIGENCE OR STRICT LIABILITY.

Further, in no event shall liability of Omron Companies exceed the individual price of the Product on which liability is asserted.

Suitability of Use.

Omron Companies shall not be responsible for conformity with any standards, codes or regulations which apply to the combination of the Product in the Buyer's application or use of the Product. At Buyer's request, Omron will provide applicable third party certification documents identifying ratings and limitations of use which apply to the Product. This information by itself is not sufficient for a complete determination of the suitability of the Product in combination with the end product, machine, system, or other application or use. Buyer shall be solely responsible for determining appropriateness of the particular Product with respect to Buyer's application, product or system. Buyer shall take application responsibility in all cases.

NEVER USE THE PRODUCT FOR AN APPLICATION INVOLVING SERIOUS RISK TO LIFE OR PROPERTY OR IN LARGE QUANTITIES WITHOUT ENSURING THAT THE SYSTEM AS A WHOLE HAS BEEN DESIGNED TO ADDRESS THE RISKS, AND THAT THE OMRON PRODUCT(S) IS PROPERLY RATED AND INSTALLED FOR THE INTENDED USE WITHIN THE OVERALL EQUIPMENT OR SYSTEM.

Programmable Products.

Omron Companies shall not be responsible for the user's programming of a programmable Product, or any consequence thereof.

Performance Data.

Data presented in Omron Company websites, catalogs and other materials is provided as a guide for the user in determining suitability and does not constitute a warranty. It may represent the result of Omron's test conditions, and the user must correlate it to actual application requirements. Actual performance is subject to the Omron's Warranty and Limitations of Liability.

Change in Specifications.

Product specifications and accessories may be changed at any time based on improvements and other reasons. It is our practice to change part numbers when published ratings or features are changed, or when significant construction changes are made. However, some specifications of the Product may be changed without any notice. When in doubt, special part numbers may be assigned to fix or establish key specifications for your application. Please consult with your Omron's representative at any time to confirm actual specifications of purchased Product.

Errors and Omissions.

Information presented by Omron Companies has been checked and is believed to be accurate; however, no responsibility is assumed for clerical, typographical or proofreading errors or omissions.

2019.7

In the interest of product improvement, specifications are subject to change without notice.

OMRON Corporation
Industrial Automation Company

<http://www.ia.omron.com/>

(c)Copyright OMRON Corporation 2019 All Right Reserved.



SCATTERGOOD & JOHNSON LTD

ELECTRICAL ENGINEERING & FLUID CONTROL DISTRIBUTORS

Est.1899

At Scattergood & Johnson Ltd, we pride ourselves on being a technical distributor to specialist industries.

Working with a range of quality product suppliers across a number of specialist markets, we are not your average 'box shifter' - we are your technical and supply chain partner.

We fully support every product we sell - for free! Our internal team and external sales engineers can answer any product or application question, no matter the complexity.

Backing up this technical ability is a range of 50,000+ products available from stock for nationwide next day delivery (same day if required!), or you can collect what you need from any of our trade counters around the UK.

Select your specialist interest below to learn more about how we can help.



Online, In Branch and On the Road - Scattergood & Johnson Ltd, there when you need us.

www.scatts.co.uk