

## Power Monitor

model **KM-N2-FLK**

## Users Manual

---

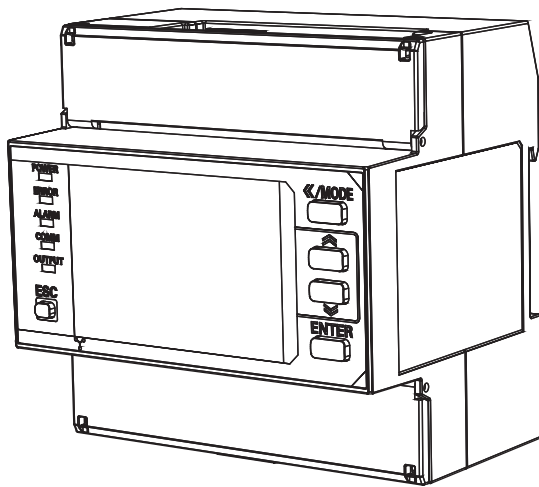

Thank you for purchasing this power monitor, model KM-N2-FLK (referred to as model KM-N2 in this manual).

This Users Manual describes the functions, performance, and application methods needed for optimum use of the unit.

Please observe the following when using this unit.

- This product is designed for use by qualified personnel with a knowledge of electrical systems.
- Before using the product, thoroughly read and understand this Users Manual to ensure correct use.
- Keep this Users Manual in a safe location so that it is available for reference whenever required.

1. Overview of the unit

2. Installation and wiring

3. Basic use

4. Settings needed to measure electricity

5. Other Functions

6. Detailed settings for communications

7. Troubleshooting

8. Appendices

# Index

---

Agreement regarding use .....	4
Safety precautions .....	7
Important safety points .....	9
Precautions for correct use.....	10
Manual revision history .....	11

## 1. Overview of the unit

1.1 Main features .....	12
1.2 Device configuration .....	13
1.3 Names of the parts and their functions.....	14
1.4 Dimensions .....	19
1.5 Multi-circuit metering .....	21
1.6 Multi-address system.....	23
1.7 Mode configuration .....	24

## 2. Installation and wiring

2.1 Attaching the body of the unit.....	25
2.2 Wiring the CTs .....	27
2.3 Wiring for power and monitored voltage input.....	29
2.4 Fitting the CTs to the measuring wires .....	31
2.5 Pulse output wiring .....	32
2.6 RS-485 wiring.....	36
2.7 Wiring diagrams .....	38

## 3. Basic use

3.1 Turning the power on.....	41
3.2 Switching between modes.....	42
3.3 How to read the measurements .....	44
3.4 How to read the setting values.....	49

## Index(continued)

---

### 4. Settings needed to measure electricity

4.1 Setting items for measuring electricity .....	53
4.2 Circuit settings .....	54
4.3 RS-485 communication settings .....	59
4.4 Pulse output settings .....	62

### 5. Other Functions

5.1 Voltage assignment.....	63
5.2 Measuring high voltage .....	64
5.3 Display unit conversion.....	65
5.4 Power saving mode.....	67
5.5 Warning for voltage miss-wiring.....	68
5.6 Tariff feature.....	69
5.7 Change password.....	70
5.8 Checking software version.....	71
5.9 Initialize .....	72

### 6. Detailed settings for communication

6.1 Overview of communications.....	74
6.2 Modbus.....	75
6.3 CompoWay/F.....	84
6.4 Address map.....	98

### 7. Troubleshooting

7.1 Warnings .....	102
7.2 Troubleshooting .....	103

### 8 Appendices

8.1 Specifications .....	106
8.2 ASCII code table .....	109
8.3 14 segment displays and 7 segment displays.....	111

# Agreement regarding use

---

Unless otherwise specifically agreed, you agree that the conditions in this agreement apply to your use of this Omron product, irrespective of the place of purchase.

## 1. Definitions

This defines some terms used in this agreement.

- (1) Omron products: FA system equipment, general-purpose control devices, sensors, and electronic/mechanical components under Omron brand.
- (2) Catalogs: Omron catalogues, including, without limitation, Omron "Best" Control Equipment Catalog, and General Catalog for Electronic/Mechanical Components, specifications, instructions and user manuals for Omron Products, whether or not provided electronically.
- (3) Usage Conditions: Usage conditions, rating, performance, operating environment, handling instructions, warnings, restrictions on use, etc. of Omron Products described in the Catalogs.
- (4) Customer Application: Any application of Omron Products by a customer to include, but are not limited to, embedding and/or using Omron Products in their parts/components, electronic substrates, devices, equipment or systems manufactured by customers.
- (5) Fitness: (a) fitness for a particular purpose, (b) performance, (c) non-infringement of third-party intellectual property, (d) compliance with laws and regulations and (e) conformity to standards of an Omron Product in the Customer Application.

## 2. Cautions regarding content

Be aware of the following points with regard to the content of Catalogs.

- (1) Rated values and performance values are based on stand-alone tests using each separate condition, and Omron does NOT warrant any rated values and performance values for multiple composite conditions.
- (2) Reference data is provided for your reference only. Omron does NOT warrant that Omron Products work properly at all times as provided in the reference data.
- (3) Application examples are provided for your reference only. Omron does NOT warrant the Fitness of Omron Products under such application.
- (4) Omron may discontinue the production of Omron Products or change their specifications for the purpose of improving such products or for other reasons entirely at its own discretion.

## 3. Precautions

You are deemed to accept the following terms when you adopt or use Omron Products:

- (1) Use Omron Products in compliance with Usage Conditions including rating and performance.
- (2) Confirm Fitness of Omron Products in Customer Application and use your own judgment to determine the appropriateness of using them in such application. Omron does NOT warrant the Fitness of Omron Products in Customer Application.
- (3) Confirm beforehand that Omron Products are properly wired and installed for their intended use in your overall system.
- (4) When using Omron Products, make sure to (i) maintain a margin of safety in relation to the published rated and performance values, such as introducing redundancy, (ii) design to minimize risks to any Customer Application in case of failure of any Omron Products, (iii) adopt system-wide safety measures to notify risks to users, and (iv) conduct regular maintenance on Omron Products and Customer Application.

## Agreement regarding use (continued)

---

- (5) Omron Products are designed and manufactured as general-purpose products for use in general industrial products. They are not intended to be used in the applications described below, therefore if you use Omron products in these applications, Omron provides no warranty for Omron products. However, this excepts cases where the use is a special use intended by Omron or where Omron has specifically agreed, even when used in the following applications.
- (a) Applications with stringent safety requirements (For example, nuclear power control equipment, combustion equipment, aerospace equipment, railway equipment, elevator and lift equipment, amusement equipment, medical equipment, safety equipment, and other applications that could cause physical injury or result in the loss of life.)
  - (b) Applications that require high reliability (For example, supply systems for gas, water and electricity, etc., 24 hour continuous operating systems, financial settlement systems and other applications that handle rights and property.)
  - (c) Applications under severe conditions or in severe environments (For example, outdoor equipment, equipment exposed to chemical contamination, equipment exposed to electromagnetic interference and equipment exposed to vibration and shocks.)
  - (d) Applications under conditions or environments not described in catalogs or other publications.
- (6) In addition to the applications listed in 3.(5) (a) to (d), the products in this publication are not intended for use in automobiles (including for two-wheeled vehicles, and this description applies hereafter). Do not use for applications involving fitting to automobiles. Consult Omron staff for information about products suitable for use in automobiles.

## Agreement regarding use (continued)

---

### 4. Warranty

The warranty for Omron Products are as follows:

- (1) Warranty period: The Warranty shall apply for one year from the date of purchase.  
(Unless otherwise described in Catalogs.)
- (2) Warranty content: Omron will provide, at its own discretion, either of the following two services as the sole remedy for a malfunctioning Omron Product:
  - (a) Repair of the malfunctioning Omron Product(s) at an Omron maintenance service location at no charge to the customer (This repair service is not available for electronic/mechanical parts.)
  - (b) Replacement of the malfunctioning Omron Product(s) with the same number of replacement/alternative products at no charge to the customer.
- (3) Exceptions: This warranty of Omron Products does not apply if the cause of the malfunction falls under any of the following:
  - (a) Usage in a manner other than the original intended use for the Omron Products.
  - (b) Usage other than as described in the Usage Conditions.
  - (c) Usage that is not in accordance with Section 3 (Precautions) above.
  - (d) Modification or repair made to the Omron Products by other than Omron personnel.
  - (e) Software program by other than Omron staff
  - (f) Causes which could not have been foreseen with the level of science and technology at the time of shipping from Omron.
  - (g) Causes other than those above originating from other than Omron or Omron Products (including force majeure such as natural disasters).

### 5. Limitation of liability

The warranty express in this agreement is the entire warranty for this Omron product.

Omron and dealers selling Omron products accept no responsibility for damages arising from the use of Omron products.

### 6. Export control

Comply with the applicable laws and regulations of Japan and related nations relating to security export controls when exporting or providing this Omron product or technical documents to non-residents. If you do not comply with these laws and regulations, we may be unable to supply you with Omron products or technical documents.

#### Notice

- It is not permitted to reproduce, copy, or reprint this manual in part or in full without permission.
- Changes to this manual may be made without notice.
- Every effort has been made to ensure the accuracy of this manual, however please contact us or your dealer at one of the addresses shown at the back of this manual if you find any unclear points or errors. At this time, please also advise us of the catalog number found at the back of this manual.

# Safety precautions

---

## Regarding the displays used to ensure safe operation and their meanings

The following indications and symbols are used in this manual for precautions so that you can use the product safely. The precautions here include important information regarding safety. Please follow these instructions.

The indications and symbols are as follows.

## Warning displays



**Caution**

Indicates a potentially hazardous situation which, if not avoided, will result in minor or moderate injury, or there may be property damage.

## Meanings of the symbols

---



- **Mandatory actions**  
Indicates a general action that must be performed by the user.
- 



- **Explosion caution**  
Indicates possibility of explosion under special conditions.
- 



- **Electrical shock caution**  
Indicates possibility of electric shock under special conditions.
- 













- **Disassembly prohibition**  
This indicates that there is the danger of electric shock or other injury if the unit is disassembled.
- 



- **General prohibitions**  
Indicates a general prohibition without particular categorization.
-

## Safety precautions (continued)

 <b>Caution</b>	
<p>Property damage may occur due to fire. Tighten the terminal screws to the specified torques. After tightening the screw, check that the screw is not loose. M3.5 screw : 0.8N·m M3 screw : 0.5 to 0.6N·m M3 screw (KM-NCT-E's output terminal) : 0.3N·m</p>	
<p>Minor or moderate injury or property damage may occur due to explosion. Do not use in locations exposed to flammable or explosive gases.</p>	
<p>Breakdown or explosion may occasionally occur. Use the power voltage and load within the specified and rate ranges.</p>	
<p>Electric shock may occasionally occur. Do not touch any of the terminals while the power is being supplied.</p>	
<p>Electric shock may occasionally occur. Always make sure that the power to the circuit the CT is being attached to is turned OFF before connecting the CT*.</p>	
<p>Electric shock may occasionally occur. Be sure to mount to coated wire with at least the basic insulation when mounting KM-NCT-E.</p>	
<p>Burns may occasionally occur. Do not touch the product while power is being supplied or immediately after power is turned OFF. Use the electric wire that heat resistant temperature is 85 degrees or more when wiring to the product.</p>	
<p>Minor electric shock, fire, or malfunction may occasionally occur. Do not supply a current to the CT input terminal that exceeds the maximum CT secondary current.</p>	
<p>Minor electric shock, fire, or malfunction may occasionally occur. Never disassemble, modify, or repair the product.</p>	

\* CT: Current Transformer

# Important safety points

---

Observe the following to ensure safe use of model KM-N2.

- Do not use or store the product in any of the following locations.
  - Locations subject to shock or vibration
  - Unstable locations
  - Locations subject to temperatures or humidity outside rated ranges
  - Locations subject to condensation as the result of severe changes in temperature
  - Outside or otherwise exposed to direct sunlight and weather
  - Locations subject to static electricity or other forms of noise
  - Locations exposed to electromagnetic fields
  - Locations subject to exposure to water or oil.
  - Locations subject to exposure to salt water spray.
  - Locations subject to corrosive gases (in particular, sulfide gas and ammonia gas).
  - Locations subject to dust (including iron dust).
  - Locations subject to exposure to solvents
- Use AWG24 to 14 to wire the power and input voltage terminals. The heat resistant temperature of the wire is 85 degrees or more.
- Use AWG18 to 14 to wire the CT terminals. The heat resistant temperature of the wire is 85 degrees or more.
- Use AWG24 to 14 to wire the communication terminals. The heat resistant temperature of the wire is 85 degrees or more.
- For wiring to KM-NCT-E's output terminal, use a Y-shape terminal compatible with AWG18 to 14 electric wire (with a cross-section of 0.75 to 2.0mm<sup>2</sup>) and M3 screw.
- The recommended tightening torque of the M3 screw of KM-NCT-E's output terminal is 0.3N·m.
- When mounting the KM-NCT-E to the measurement wire, push the fitting claw until it clicks.
- Be sure to wire properly with the correct terminal number. Do not wire unused terminals.
- Be sure to check that the wiring is correct before turning on the power.
- Before using or maintaining the product, thoroughly read and understand the instruction manual.
- Understand the user manual before setting the device.
- Do not pull cables.
- Use only as described in the INSTRUCTION MANUAL. Using the unit in a manner not described may result in the safety functionality of the device being compromised.
- In order that workers may turn off the power immediately, install a branch circuit breaker conforming to requirements in the country where the device is being used (USA: UL Listed, CANADA: cUL Listed, other country: e.g. IEC60947-1 and IEC60947-3 ) and display instructions properly.  
<Recommended ratings of a branch circuit breaker>  
Rated current : 1A.
- Always check the wiring and confirm that it is correct before turning ON the power supply. Incorrect or improper wiring may result in electrical shock, injury, accidents, failure, or malfunction.
- KM-NCT-E is a dedicated CT for KM-N2-FLK and KM-N3-FLK. Do not use it for other power monitors.
- The surface temperature of the CT may become high due to the heat generated by the primary power cable. Be sure to check that the surface temperature of the CT went down before touching the CT immediately after turning ON the power supply.
- Do not install the product close to heat-producing devices (those using coil elements, for instance).
- Ensure the screws fixing the DIN rails are tight. Also ensure that the DIN rails and the body are attached properly. Looseness may cause the DIN rails, body, and wires to separate if vibrations or impacts occur.
- Use 35mm width DIN rails (OMRON, model PFP-50N/-100N).
- When mounting the product on the DIN rail, slide the DIN hook unit until a clicking sound is heard.
- Separate the product wiring from high-voltage or high-current power lines to prevent inductive noise. Do not place the product wiring parallel to or in the same ducts or conduits as power lines. Use separate ducts, separate conduits, or shielded cables to prevent noise.
- This is a "class A" product. In residential areas it may cause radio interference. The user may be required to take adequate measures to reduce interference if this occurs.

# Precautions for correct use

---

- This product is not categorized as "a specified measuring instrument" officially approved by an organization specified in relevant measurement acts. It cannot be used to certify power usage.
- Set the parameters of the product so that they are suitable for the system being measured.
- Mount this product on DIN rails for use.
- Use varistors between the outer power and voltage measuring input wires when this product is installed in an overvoltage category III environment.
- This product cannot be used to measure the inverter's secondary side.
- Ensure that the rated voltage is reached within 2 seconds of turning the power on.
- Do not use thinners for cleaning. Use commercial alcohol.
- When cleaning the unit, make sure the power is off and wipe the surface of the unit with a soft dry cloth. Do not use chemicals including solvents such as thinners, benzine, or alcohol.
- You cannot use the CT dedicated for use with the Omron KM series (model series KM20-CTF, model series KM-NCT). Use a CT whose secondary output is 1A or 5A.
- Use ferrule terminals to connect CTs to the CT terminals on the main unit to ensure the assembly complies with standards.
- The data for active energy is saved at 5 minute intervals. The data for the 5 minutes preceding the unit powering off may not be saved under some circumstances.
- Dispose of this product appropriately as industrial refuse in accordance with local and national regulations.
- This product is intended for use in industrial environments. Do not use it in residential environment.

---

## Trademark Information

- Modbus is a registered trademark of Schneider Electric.
  - Other company names and product names in this document are the trademarks or registered trademarks of their respective companies.
-

# Manual revision history

---

A manual revision code appears as a suffix to the catalog number on the front cover and back cover of the manual.

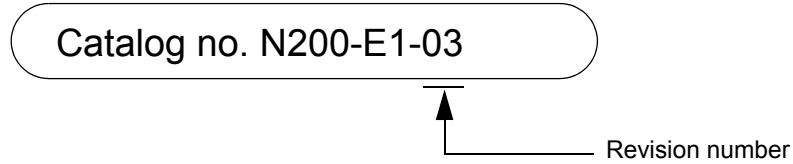

Revision number	Date of revision	Reason for revision, pages revised
01 A	April 2016	First edition
02	July 2017	Description of operability-confirmed converter: Modified
03	May 2018	Description of dedicated CT: Added

# 1.1 Main features

---

- Supports international standards

It complies with the international IEC accuracy standards and can be connected using generic CTs.

- Multi-circuit metering

Multi-circuit metering is possible with one unit, with up to four circuits metered by 1-phase 2-wire, and up to 2 circuits metered by 1-phase 3-wire and 3-phase 3-wire. It is also possible to measure multiple 1-phase 2-wire with different phases branching off a 1-phase 3-wire, and to simultaneously measure both 1-phase 3-wire and 1-phase 2-wire.

- Multi-address system

There can be a maximum of 4 circuits in one unit. The circuits act as independent power monitors, each able to measure, each having different settings, and each able to be allocated different communications addresses. You can manage individual circuits as electricity monitors from a host system, so it is easy to build a communications system and add places for measuring.

- Pulse output

The unit has 4 ports for outputting pulses each time the active energy exceeds set values. You can allocate each circuit a pulse output port in a multi-circuit metering setup.

- RS-485 communications

You can use the Modbus (\*1) and CompoWay/F (\*2) protocols for RS-485 communications.

\*1. Modbus is a communications control system that conforms with the RTU Mode of the Modbus Protocol.

\*2. CompoWay/F is Omron's unified communication procedure for general serial communications. It has a unified framework format and has commands compliant with FINS which works well with Omron programmable controllers, for instance, simplifying communications between host devices (computers for example) and components.

## 1.2 Device configuration

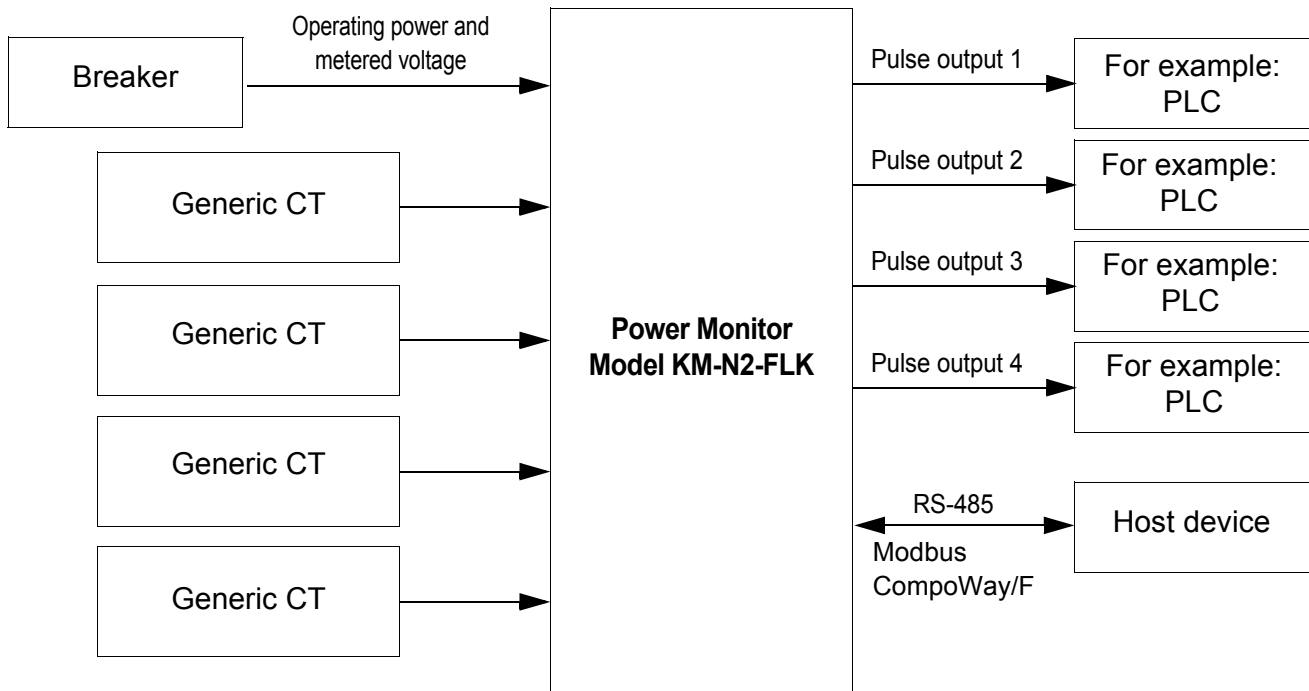

- The CT of OMRON's dedicated KM series output type cannot be used with this product.
- Although a generic CT with the secondary side output of 1A or 5A can be connected, CTs dedicated for use with KM-N2-LFK and KM-N3-FLK of 1A output type are available as listed on the table below. By using a CT listed below in combination with a KM-N2-FLK, the CE standard is supported including the use of CT and power monitors.
- A cable to connect the CT and power monitor is separately required.

Name	Model	Description
CT dedicated for 1A output type	KM-NCT-E100A	Rated 100A, output 1A
	KM-NCT-E250A	Rated 250A, output 1A
	KM-NCT-E500A	Rated 500A, output 1A

# 1.3 Names of the parts and their functions

**[Main unit]**

**Front**

Terminal panel cover removed

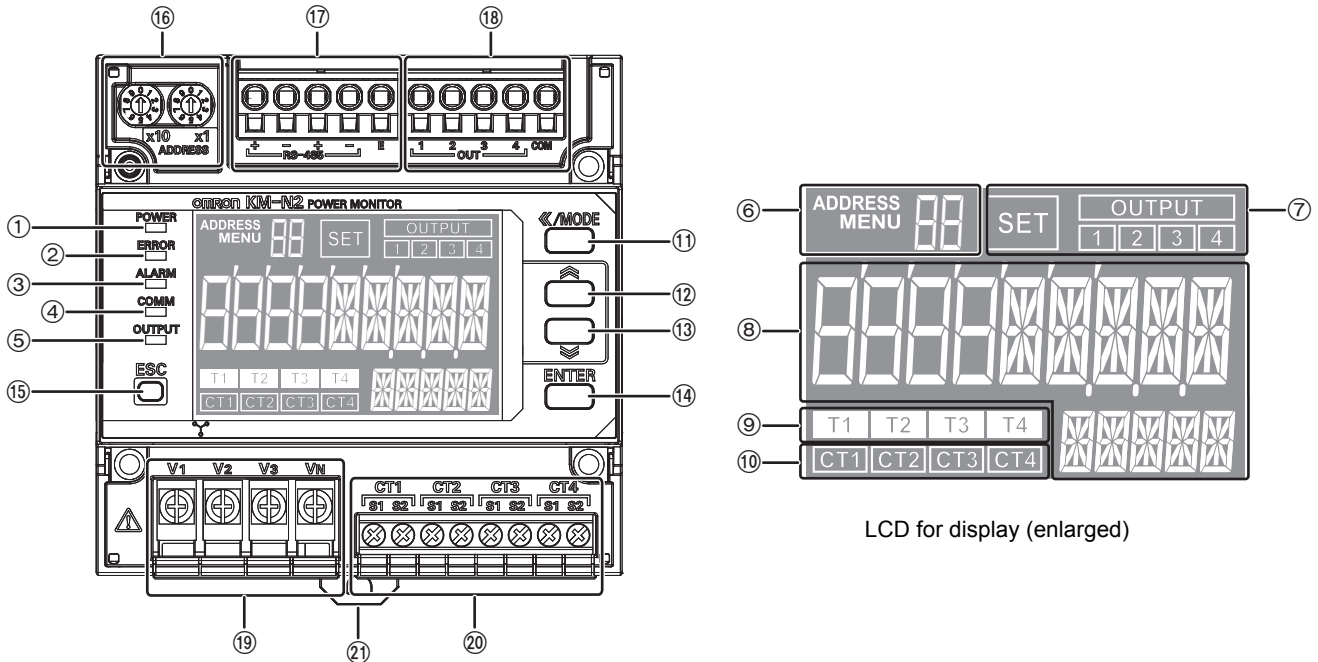

LCD for display (enlarged)

Name		Description
①	Power LED (green)	Lights when power is supplied
②	Error LED (red)	Flashes when there is an error such as a malfunction
③	Alarm LED (orange)	Flashes to indicate a warning
④	Communication LED (yellow)	Lights when communicating
⑤	Pulse LED (yellow)	Lights during pulse output
⑥	Communication address/Menu display	When ADDRESS is illuminated (in measuring mode): Displays the communication address
		When MENU is illuminated (in setting mode): Displays the menu number
⑦	OUTPUT	Lights when setting pulse output
	1	Lights when outputting pulse from OUT1
	2	Lights when outputting pulse from OUT2
	3	Lights when outputting pulse from OUT3
	4	Lights when outputting pulse from OUT4
	SET	Lights in setting mode
⑧	Main display	Displays measured values and setting values (9 places on the upper line)
	Sub display	Displays the units for the measured values and the names of the setting items (5 places on the lower line)
⑨	Tariff display	Displays the tariff number (T1 to T4) when saving active energy (import)

## 1.3 Names of the parts and their functions (continued)

Name		Description
⑩CT usage display		Displays the CT number (CT1 to CT4) when measuring or setting
⑪<</MODE key		Short press: switch circuit/move place Press and hold: switch mode
⑫⤴Key		Change setting or value (up)
⑬⤵Key		Change setting or value (down)
⑭ENTER key		Confirm setting or value
⑮ESC key		Cancels items or values
⑯Rotary SW		Sets the communication address* (left (x10): increase in units of ten, right (x1): increase in units of 1)
⑰RS-485 communication terminals	RS-485+(1)	RS-485+ terminal
	RS-485-(1)	RS-485- terminal
	RS485+(2)	RS-485+ terminal (for crossover wiring)
	RS485-(2)	RS-485- terminal (for crossover wiring)
	RS485 E	RS-485 terminating resistor terminals
⑱Pulse output terminal	OUT1	Pulse output 1 terminal
	OUT2	Pulse output 2 terminal
	OUT3	Pulse output 3 terminal
	OUT4	Pulse output 4 terminal
	COM	Common terminal for pulse output
⑲Voltage input terminals		Terminals for inputting the power and voltage (combined with the input for measured voltage)
⑳CT input terminals		Terminal for connecting the CT cables for CT1 to CT4
㉑DIN Hook		Hook for attaching to the DIN rail

\* Refer to "1.6 Multi-address system" (⇒ 23) for circuit A.

### 1.3 Names of the parts and their functions (continued)

Right side surface

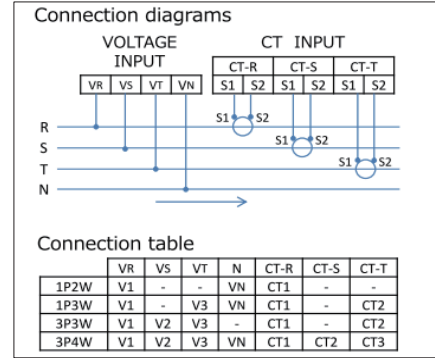
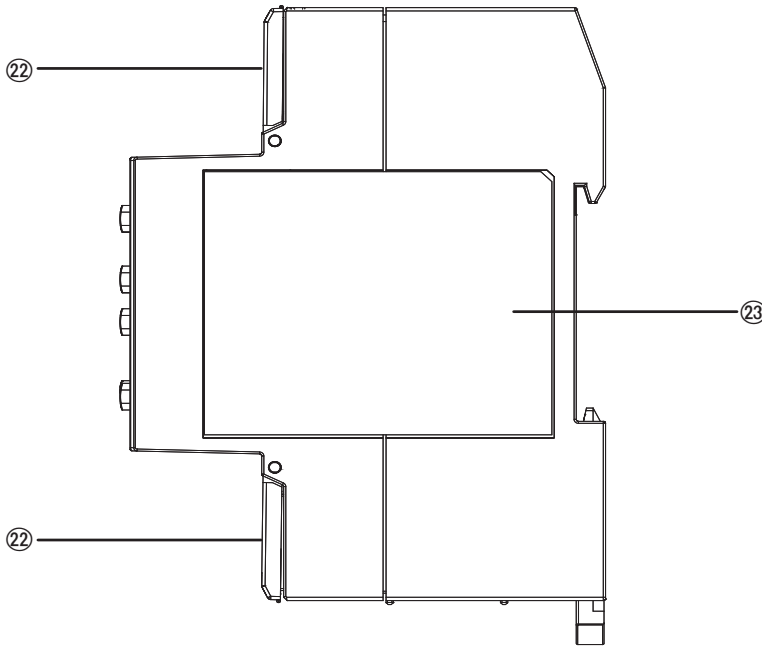

Enlarged terminal layout label

Name	Description
② Terminal layout label	Label with information such as the model, power voltage, connector layout, and serial number
③ Terminal panel cover	Terminal panel cover with seal

## 1.3 Names of the parts and their functions (continued)

### [Dedicated CT]

KM-NCT-E100A, -250A

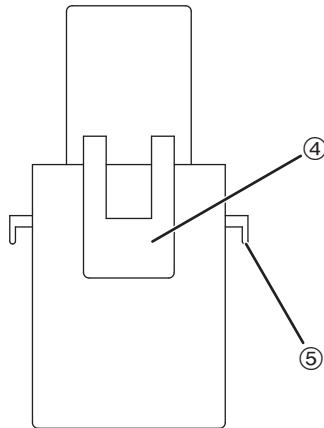

(Front)

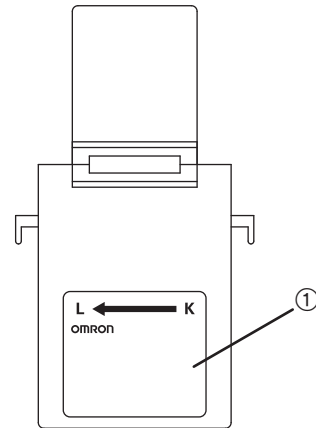

(Back)

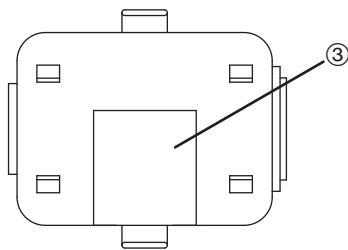

(Bottom)

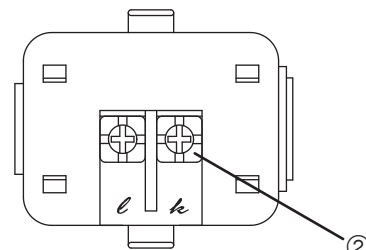

(Bottom (terminal cover removed))

Name	Function
① Label	Polarity of the primary side wiring, and models are written on this label
② Output terminal block	Secondary side current is output to this terminal block
③ Terminal cover	Protective cover of the output terminal block
④ Fitting claw	Claw that clamps the wire and fits the top and bottom of the transformer
⑤ Fixing claw	Used to reinforce the retention of the unit and insulation lock

## 1.3 Names of the parts and their functions (continued)

KM-NCT-E500A

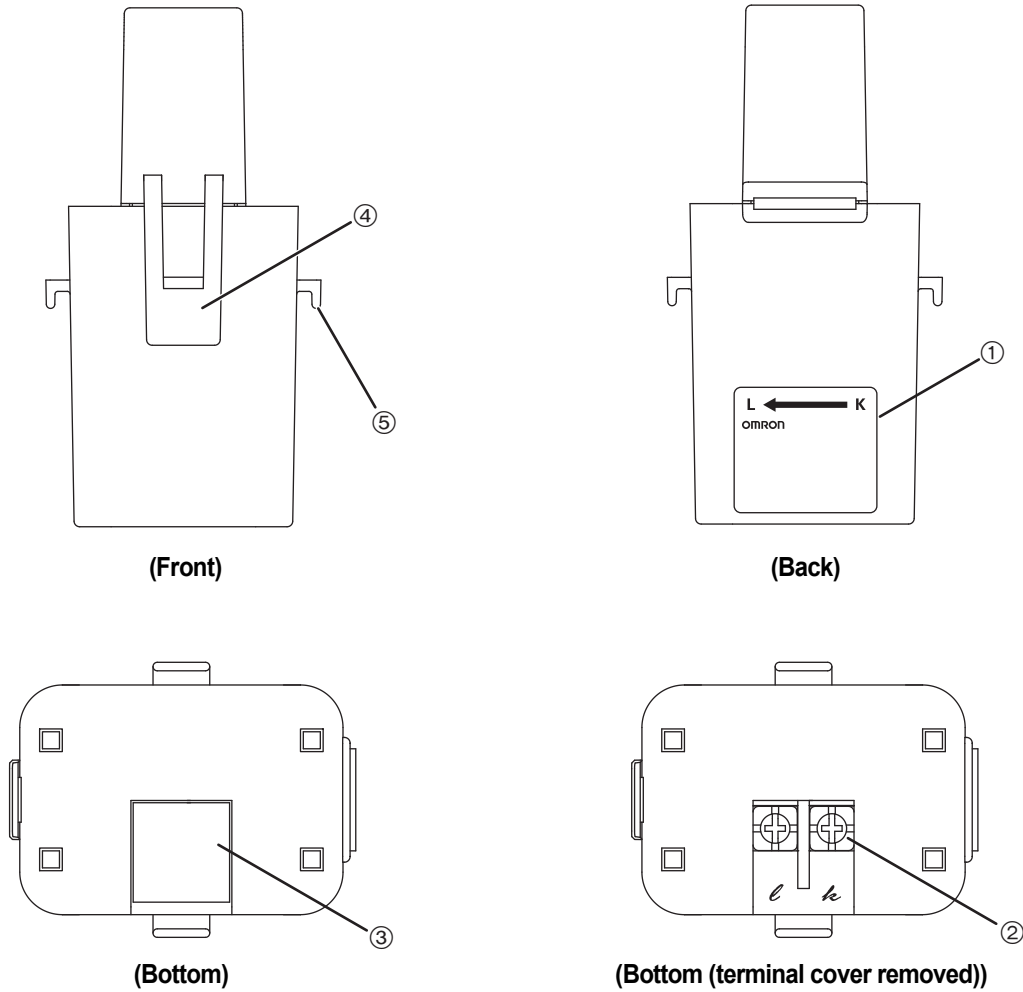

Name	Function
① Label	Polarity of the primary side wiring, and models are written on this label
② Output terminal block	Secondary side current is output to this terminal block
③ Terminal cover	Protective cover of the output terminal block
④ Fitting claw	Claw that clamps the wire and fits the top and bottom of the transformer
⑤ Fixing claw	Used to reinforce the retention of the unit and insulation lock

# 1.4 Dimensions

## [Main unit]

Units (mm)

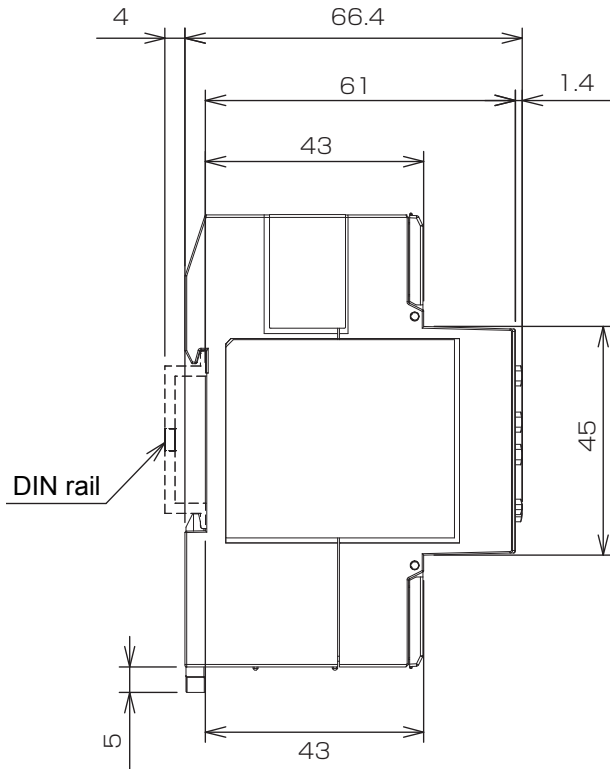

(Left side surface)

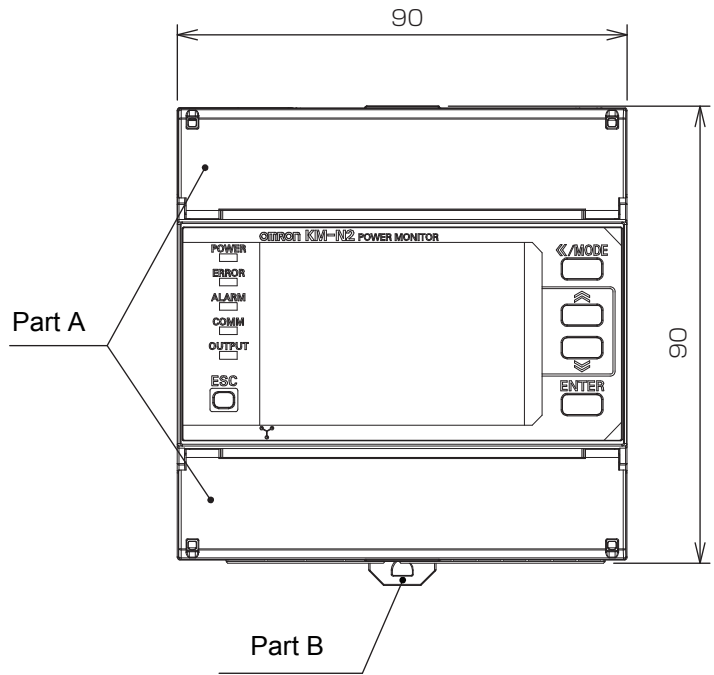

(Front)

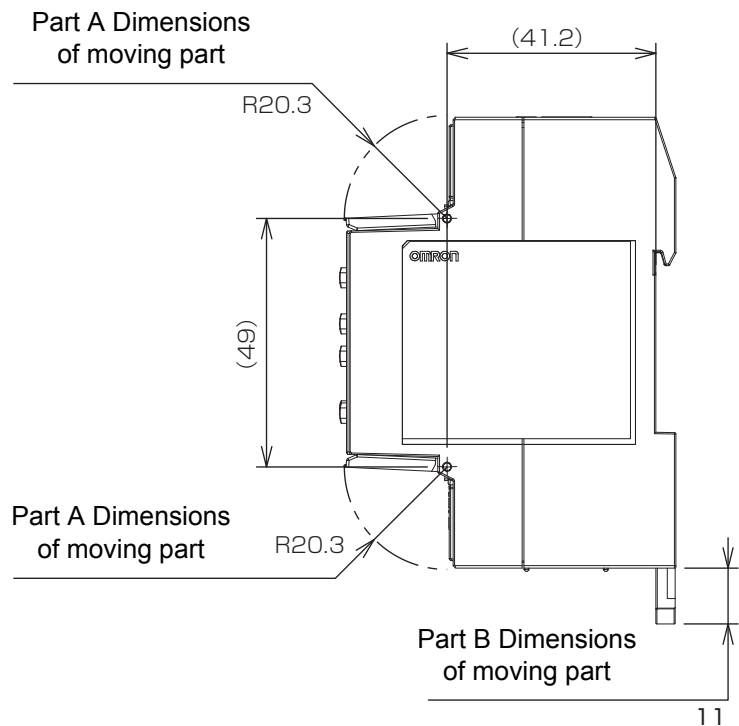

(Right side surface)

## 1.4 Dimensions (continued)

### [Dedicated CT] KM-NCT-E100A, -250A

Units (mm)

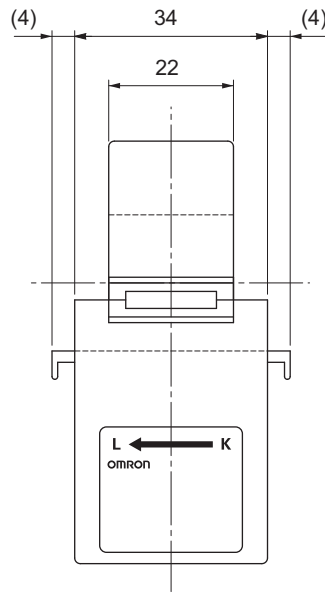
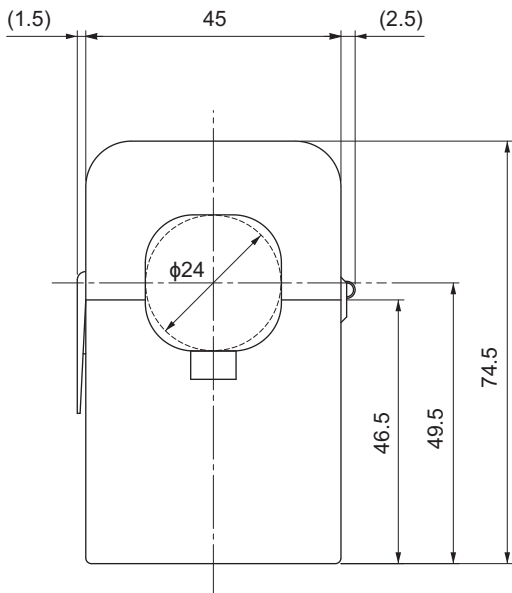

CT INNER DIAMETER

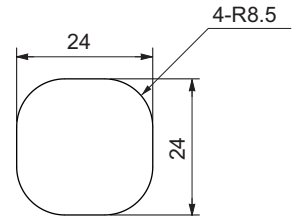

### KM-NCT-E500A

Units (mm)

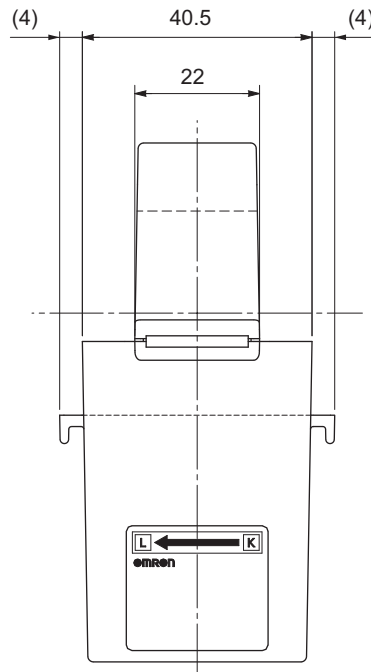
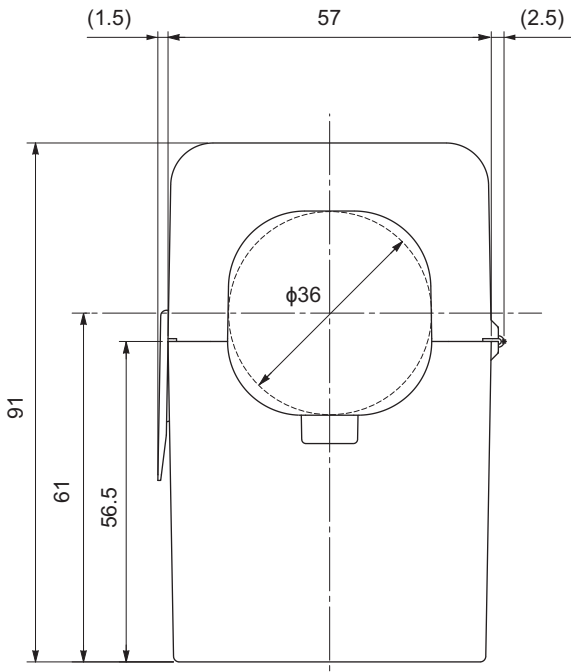

CT INNER DIAMETER

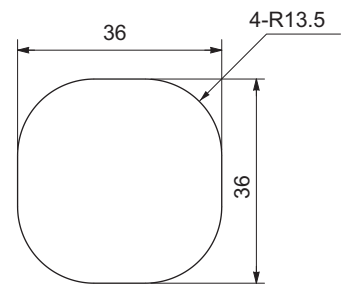

## 1.5 Multi-circuit metering

Multi-circuit metering is possible with this product. Measuring circuit refers to the measurement point where electricity measuring is conducted. Furthermore, this product measures voltage commonly across all circuits and measures current with each separate circuit by using generic CTs.

### ● Maximum number of measuring circuits for each phase and wire type

You can connect up to 4 generic CTs to this unit. The phase and wire types and the usable number of measuring circuits are shown in the following table.

Refer to "2.7Wiring diagrams (⇒ 38)" for more on wiring each of the phase and wire types.

Phase and wire type	Abbreviations for phase and wire types	Maximum number of measuring circuits	Circuits used
3-phase 4-wire	3P4W	1 circuit	Circuit A
1-phase 2-wire	1P2W	4 circuit	Circuit A, Circuit B, Circuit C, Circuit D
1-phase 3-wire	1P3W	2 circuit	Circuit A, Circuit C
3-phase 3-wire	3P3W	2 circuit	Circuit A, Circuit C
1-phase 2-wire voltage selected	1P2W2	4 circuit	Circuit A, Circuit B, Circuit C, Circuit D
1-phase 3-wire composite	1P3W2	1-phase 3-wire: 1 circuit	Circuit A
		1-phase 2-wire: 2 circuit	Circuit C, Circuit D

- Set 1-phase 2-wire voltage selected when measuring multiple 1-phase 2-wire with different phases branching off a 1-phase 3-wire switchboard. You can measure 1-phase 2-wire by selecting the corresponding voltage.
- Set 1-phase 3-wire composite to measure both the main 1-phase 3-wire switchboard and a 1-phase 2-wire branching off.  
You can measure 1-phase 2-wire by selecting the corresponding voltage.
- Refer to "5.1Voltage assignment (⇒ 63)" for more on 1-phase 2-wire voltage selected and 1-phase 3-wire composite.

## 1.5 Multi-circuit metering (continued)

- **Allocating the circuits used and the CTs for each phase and wire type**

The following table shows the phase and wire types and the CT allocations for each measuring circuits. As circuit A is used irrespective of the phase and wire type, you must make settings for measurement ("Circuit A settings(⇒ 54)").

By enabling circuits B to D to increase the number of measurement points ("Settings for circuits B to D (when measuring 2 circuits or more) (⇒ 56)"), you can meter electricity using the required number of circuits. This are disabled by default.

Phase and wire type	Abbreviations for phase and wire types	Measuring circuits			
		Circuit A	Circuit B	Circuit C	Circuit D
3-phase 4-wire	3P4W	CT1, CT2, CT3	—	—	—
1-phase 2-wire	1P2W	CT1	CT2	CT3	CT4
1-phase 3-wire	1P3W	CT1, CT2	—	CT3, CT4	—
3-phase 3-wire	3P3W	CT1, CT2	—	CT3, CT4	—
1-phase 2-wire voltage selected	1P2W2	CT1	CT2	CT3	CT4
1-phase 3-wire composite	1P3W2	CT1, CT2	—	CT3	CT4

## 1.6 Multi-address system

This product is a multi-address system where different communications addresses (numbered in order) are allocated to each circuit. The communications addresses correspond to each measuring point, so data transmission management from the host device is simplified.

The following diagram is an overview of the multi-address system.

The measurement values and setting values for individual circuits are accessed via communications addresses for each of the circuits. The common settings are common to all of the circuits, so they can be accessed using any of the communications addresses, which allows changes to settings for all of the circuits at once.

Refer to "6.Detailed settings for communications (⇒ 74)" for details about commands, responses, and address maps.

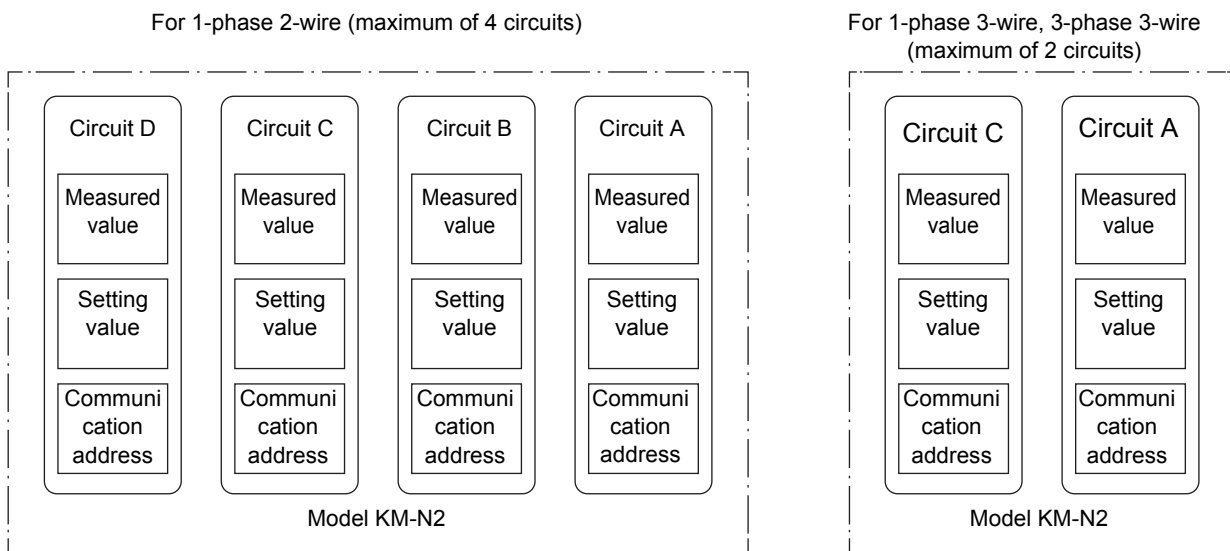

### Caution

- Each circuit on this product needs to be allocated different communications addresses (numbered in order). Even if you connect several of these products on the same RS-485 line, all of the circuits need to be allocated different communications addresses.

# 1.7 Mode configuration

This model has three modes: measuring mode, setting mode, and communication setting mode.

- Measuring mode: The measured values for each circuit are displayed.
- Setting mode: By operating keys on the body of the unit you can change settings for each of the circuits, and make common settings for communications, output, the display, etc.
- Communication setting mode: Make settings on the units using RS-485 communication.

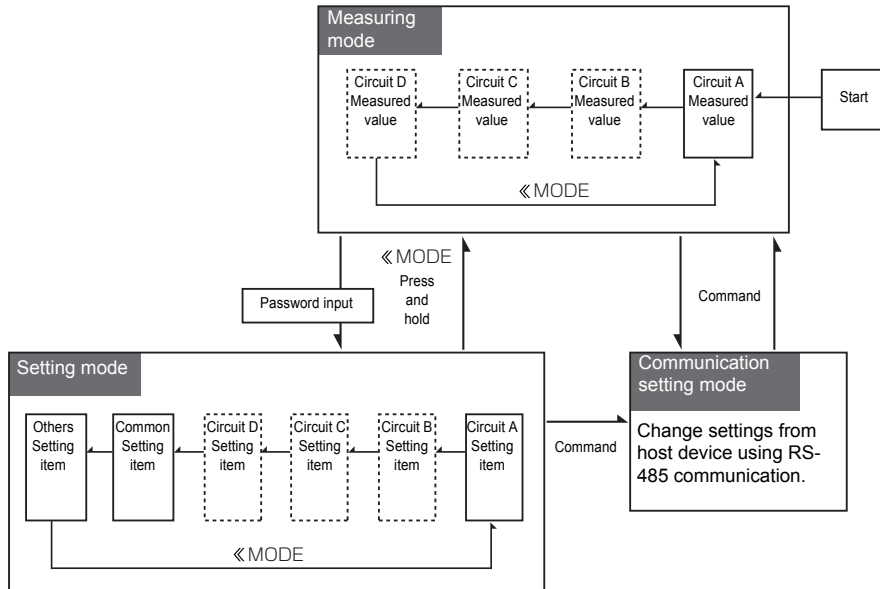

- In the measuring mode and setting mode, the circuit B to D items are displayed by switching the enable/disable settings for each of the circuits to "ON" (enabled). (The circuits indicated inside the dotted lines in the above diagram are "OFF" (disabled) in the default state.)

## 2.1 Attaching the body of the unit

For safety purposes, install the unit in a location where you won't touch the terminals when operating the main unit. For example, install so that the terminals are hidden within the control board so that a person working on the unit will not be able to touch live wires.

### 1 Fix the DIN rail to the installation location

– DIN rail (recommended product): Model PFP-50N/-100N (from Omron)

### 2 Pull down the DIN hook on the bottom of the body of the unit

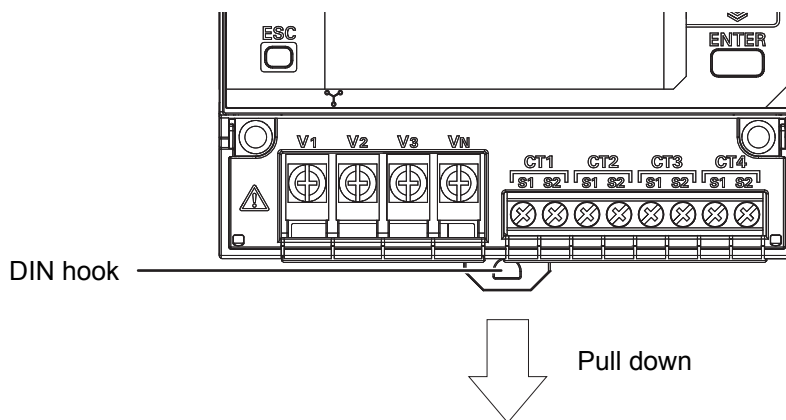

### 3 Fit the flanges of the body onto the DIN rail as shown in the below diagram, and click into place

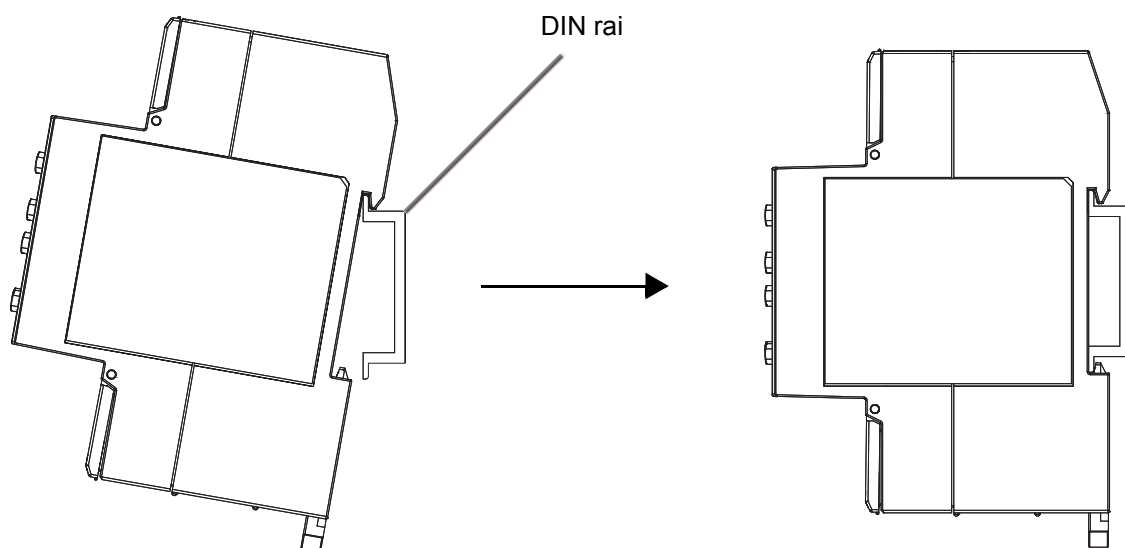

### 2.1 Attaching the body of the unit (continued)

#### 4 Raise the DIN hook and fix the body to the DIN rail

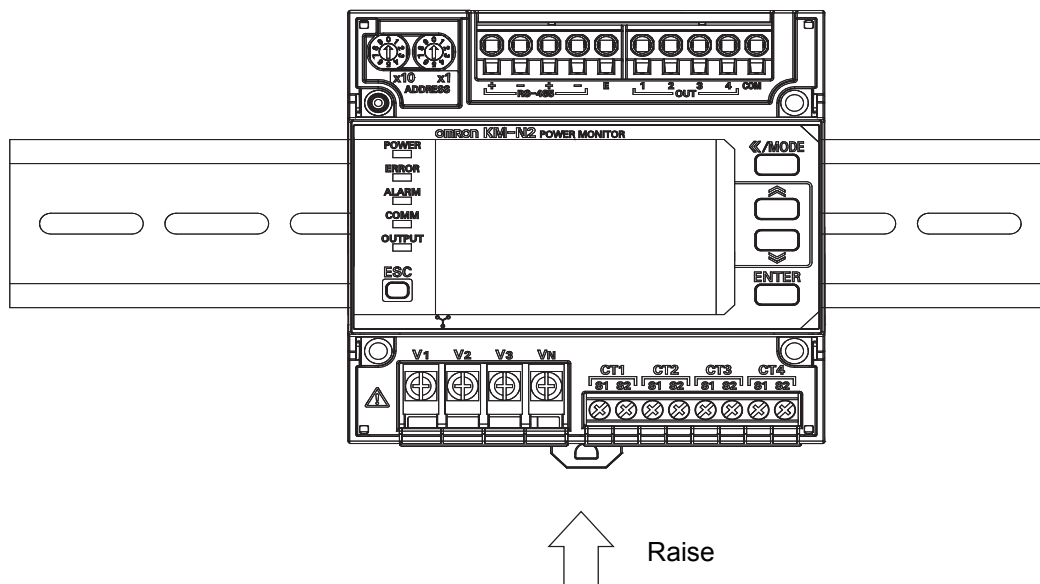

#### Detaching the body of the unit

When removing the body from the DIN rail, use a flathead screwdriver to flick open the DIN hook and open downwards.

#### Important

- Ensure that the DIN rails and the body are attached properly. Looseness may cause the DIN rails, body, and wires to separate if vibrations or impacts occur.
- Fix end plates to the body units at each end of the DIN rail.  
These stop the units from jumping off the DIN rail due to vibration or impacts.  
– End plate (recommended part): model PFP-M (from Omron)
- Make sure you install so there is space for wiring above and below the body of the unit.  
(about 50mm above the unit and 30mm below the unit)

#### Information

- You can attach multiple model KM-N2 to the DIN rail and fit the bodies next to each other.

## 2.2 Wiring the CTs

You can connect up to a maximum of 4 generic CTs to this unit ( $\Rightarrow$  21). The number of CTs used depends on the phase and wire type of the power source being monitored. The following table shows the phase and wire types and the CTs to use for each. For example, use CT1 when measuring only one 1-phase 2-wire circuit. Further, when measuring two 1-phase 3-wire circuits, use CT1 and CT2 for circuit A and use CT3 and CT4 for circuit C.

The layout of CT input terminals is as follows.

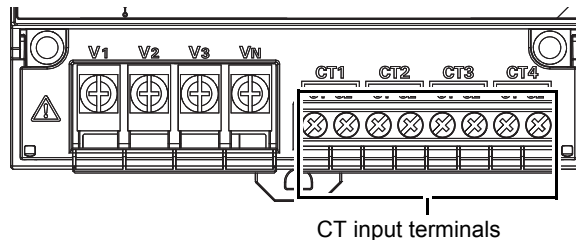

The following table shows the phase and wire types and the CT allocations for each measuring circuits.

Phase and wire type	Abbreviations for phase and wire types	Measuring circuits			
		Circuit A	Circuit B	Circuit C	Circuit D
3-phase 4-wire	3P4W	CT1, CT2, CT3	—	—	—
1-phase 2-wire	1P2W	CT1	CT2	CT3	CT4
1-phase 3-wire	1P3W	CT1, CT2	—	CT3, CT4	—
3-phase 3-wire	3P3W	CT1, CT2	—	CT3, CT4	—
1-phase 2-wire voltage selected	1P2W2	CT1	CT2	CT3	CT4
1-phase 3-wire composite	1P3W2	CT1, CT2	—	CT3	CT4

- Connect the CT cables for CT1/CT2/CT3/CT4 to the terminals on the main unit that are labeled CT1/CT2/CT3/CT4.
- For details about how to wire the CTs, refer to the manual of the CTs you are using.

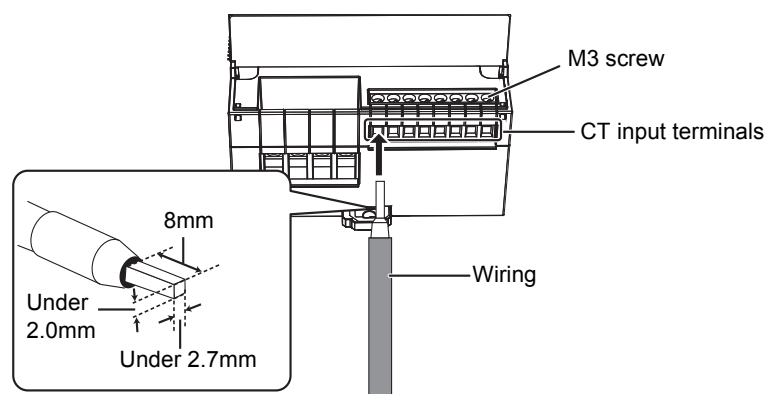

### Important

- Do not try to connect or disconnect CTs or CT cables during measurement or while the power of this product is on. There is a danger of electric shock. Furthermore, this may cause this unit and the CT to malfunction.
- For wiring to the CT input terminals, use 18 to 14 AWG (cross section surface area of 0.75 to 2.0mm<sup>2</sup>) electrical wire.
- Use ferrule terminals suitable for the wire diameter to connect to the CT input terminals.
- The recommended torque for the 3mm screws is between 0.5 and 0.6Nm. Make sure the ferrule terminal is pushed all the way in and tightened firmly. After fixing the wiring in place, pull gently to confirm that the wiring is fixed firmly.

## 2.2 Wiring the CTs (continued)

### Using KM-NCT-E□□□A

The wiring method when using the KM-NCT-E□□□A, a dedicated CT for 1A output, is as follows.

- For wiring of the output terminal of CT, use AWG18-14 electric wire (with a cross-section of 0.75-2.0mm<sup>2</sup>) and Y-shape terminal compatible with the M3 screw.
- The recommended torque for screwing the M3 screws onto the output terminal is 0.3 N·m. Make sure the Y terminal is pushed all the way in and tightened firmly. After fixing the wiring, confirm that the wire is fixed securely.
- The guideline of the maximum wiring length between the main unit and CT is as follows.

Wiring diameter	Guideline for wiring length limit
0.75 mm <sup>2</sup> (AWG18 equivalent)	15m
2.0 mm <sup>2</sup> (AWG14 equivalent)	43m

- The limit of the wiring length can also be calculated by the following formula. Calculate the wiring length limit according to the conductor resistivity of the wiring and keep the wiring length below the limit.
- The limits of the wiring length as shown on the table and expression below are for reference only. They do not guarantee proper use. They do not guarantee proper use.

$$\text{Wiring extension limit value (one-way) (m)} = 0.475 / \text{conductor resistivity } (\Omega/\text{m})$$

## 2.3 Wiring for power and monitored voltage input

Voltage input terminals V1/V2/V3/VN on this product act as both operating power terminals and as voltage measuring terminals.

The layout of voltage input terminals is as follows.

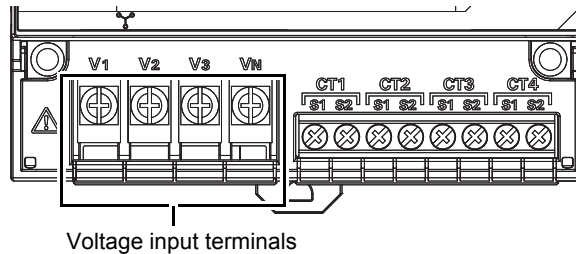

Phase and wire type	Voltage input terminals			
	V1	V2	V3	VN
4-phase 3-wire	R	S	T	N
1-phase 2-wire	L	—	—	N
1-phase 3-wire	R	—	T	N
3-phase 3-wire	R	S	T	—

### Information

- R/S/T/N may be labeled U/V/W/O or L1/L2/L3/N in some cases.
- R/N/T may be labeled U/O/W or L1/N/L2 in some cases.

To wire the voltage input terminal, loosen the 3.5mm screw on the terminal panel, push the wire completely into the terminal, and fix in place with the crimping terminal.

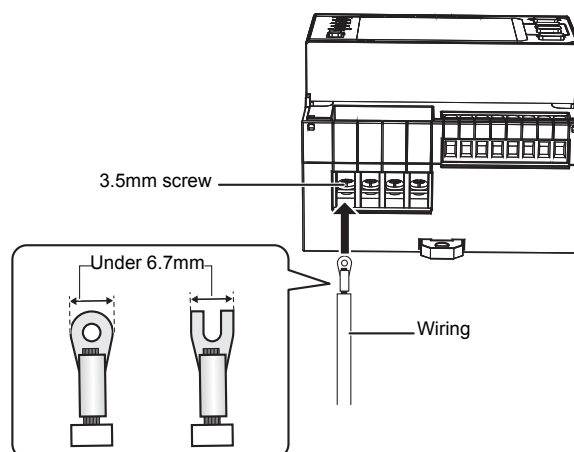

### Information

- The terminal panel cover fixes in place when you open it fully so it won't get in your way when you are tightening the screws, etc.

### 2.3 Wiring for power and monitored voltage input (continued)

Wire the device according to the phase and wire type as shown in the following diagram.

Install a branch circuit breaker between the wiring for each of R/S/T/N, L/N and R/N/T so that the power can be turned off immediately.

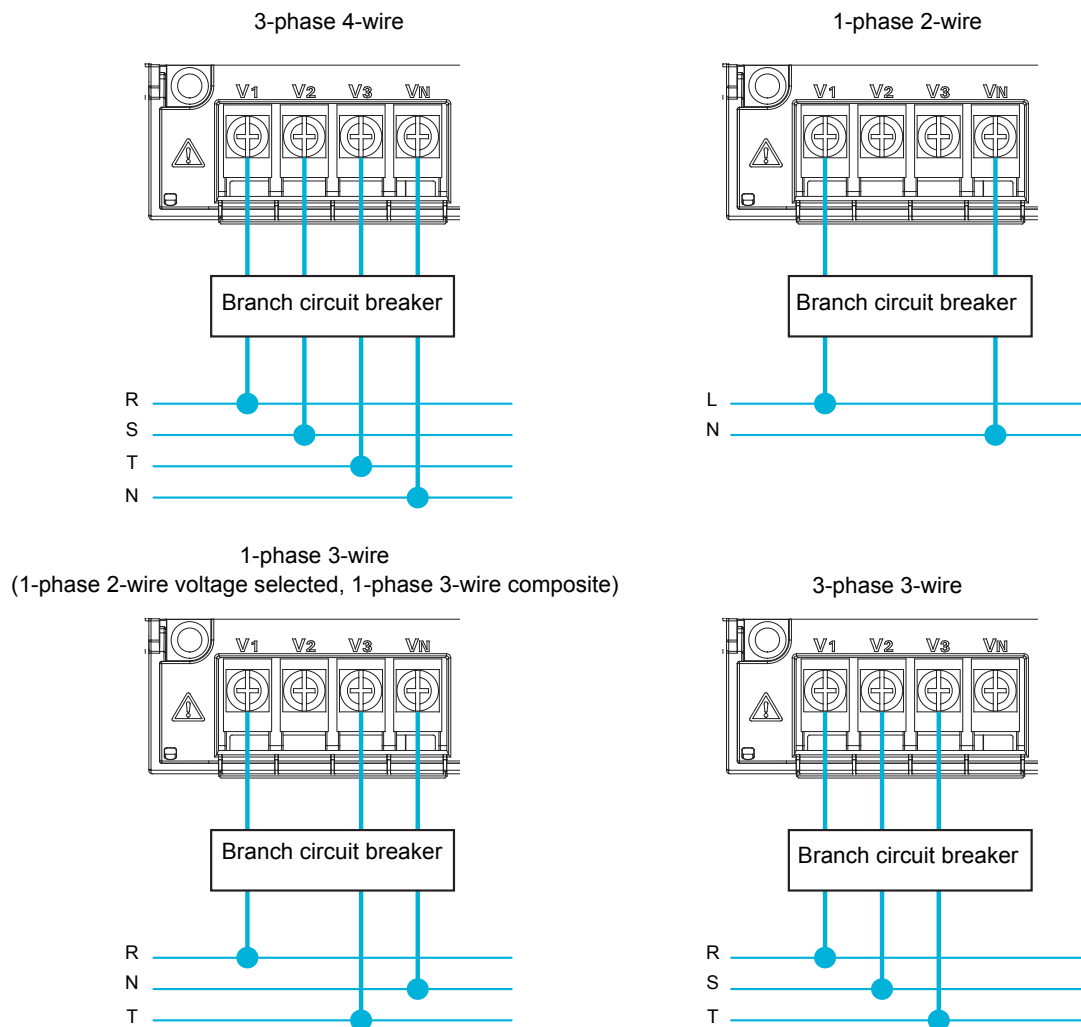

#### Important

- For safety purposes, turn off the mains power and set the branch circuit breaker to off to ensure there is no power supply while you are working.
- Wire correctly so the phase sequence is correct. You will be unable to measure the power and energy correctly if you fail to do so.
- For the wiring for the power and measured voltage, use 24 to 14 AWG (cross section surface area of 0.2 to 2.0mm<sup>2</sup>) electrical wire and ring or U-shaped crimp connectors suitable for 3.5mm screws.
- The recommended torque for screwing the 3.5mm screws is 0.8Nm. Make sure the crimping terminal is pushed all the way in and tightened firmly. After fixing the wiring in place, pull gently to confirm that the wiring is fixed firmly.
- During use, make sure the terminal panel cover is closed.

## 2.4 Fitting the CTs to the measuring wires

When monitoring one circuit with 1-phase 2-wire, you need one CT. When monitoring one circuit with 1-phase 3-wire, you need 2 CTs. When monitoring one circuit with 3-phase 4-wire, you need 3 CTs. The following diagram is an example of fitting CTs when monitoring one circuit with 1-phase 2-wire.

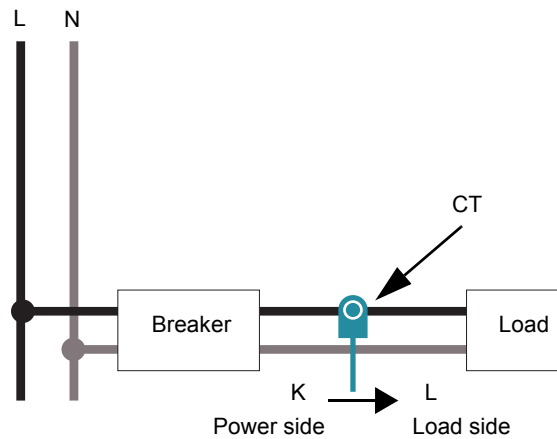

- For details about how to connect the CTs to the measuring wires, refer to the manual of the CTs you are using.
- Fit the CTs to the measuring wires after connecting the CT cables to the unit.
- Attach to the L-phase if measuring 1-phase 2-wire.  
Attach to the R-phase and T-phase if measuring 1-phase 3-wire or 3-phase 3-wire.  
Attach to the R-phase, S-phase, and T-phase if measuring 3-phase 4-wire.
- Refer to "2.7 Wiring diagrams (⇒ 38)" for more on attaching CTs according to the phase and wire types.
- CTs have polarity. Check the directionality of the power side (K) and the load side (L) before connecting. You will be unable to measure correctly if you make a mistake with the directions.

### Important

- **Electric shock may occasionally occur.**  
**Always make sure that the power is turned OFF before connecting the CT.**
- **Make sure that the primary electrical wire clamped at the CT is insulated coated wire.**
- **Do not expose the CTs to excessive vibrations or impacts.**

## 2.5 Pulse output wiring

Wire the pulse output terminals if using the pulse output feature. The layout of pulse output terminals is as follows.

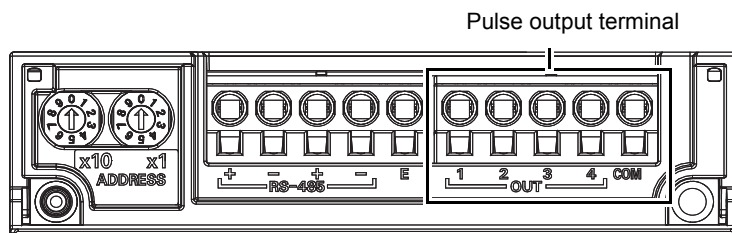

Terminal number	Terminal name	Description
1	OUT1	Pulse output 1
2	OUT2	Pulse output 2
3	OUT3	Pulse output 3
4	OUT4	Pulse output 4
5	COM	Common (common to the four outputs)

Push the wire to the very back of the pulse output terminals while pressing on the release hole. Refer to "Cautions when connecting the Push-In Plus terminal (RS-485 communication terminal and pulse output terminal)(⇒ 34)" for details about wiring and connections.

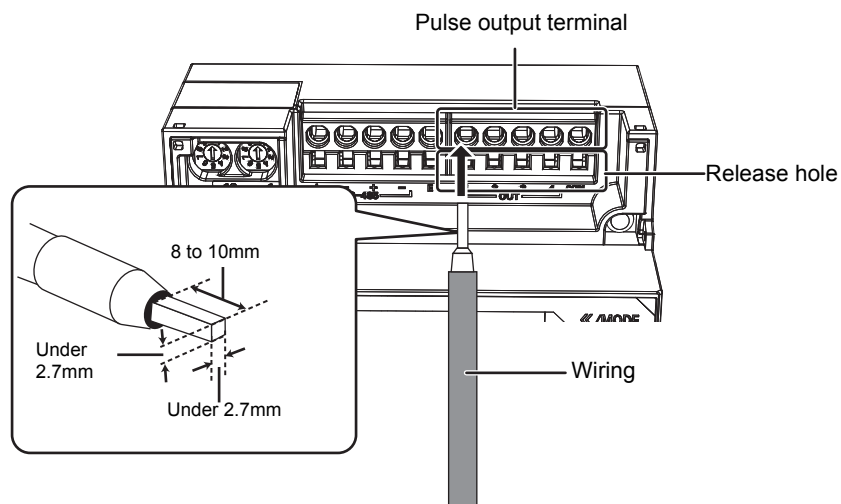

## 2.5 Pulse output wiring (continued)

The following diagram shows wiring for pulse output.

This unit is equipped with 4 pulse outputs. The common terminal (number 5) is a common terminal.

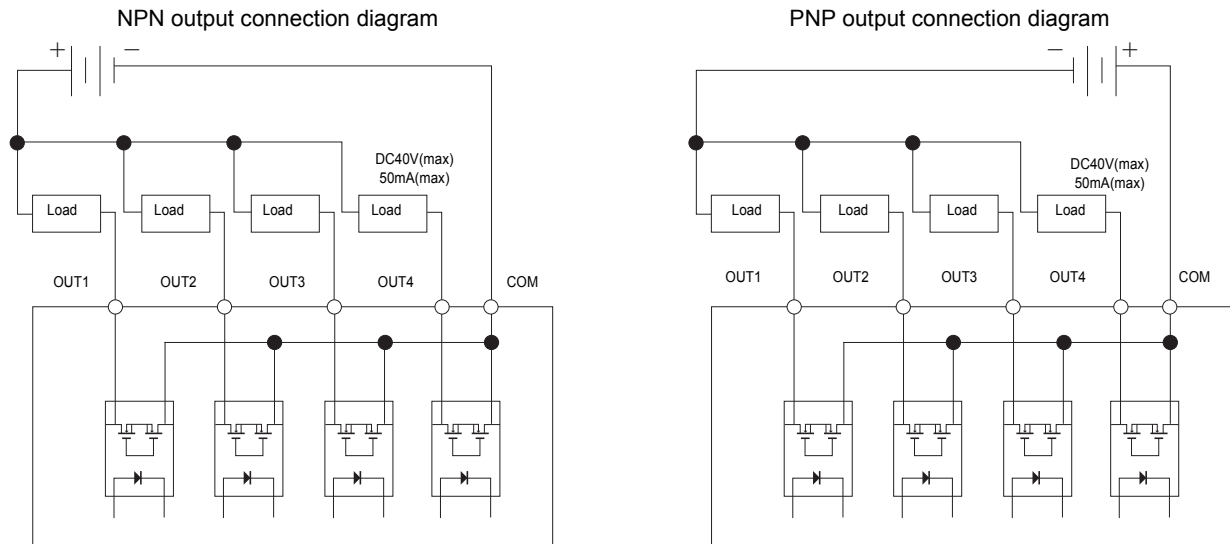

The table below shows the output specifications.

<b>Output capacity</b>	DC40V, 50mA or less
<b>Residual voltage when ON</b>	Less than 1.5V (when output current is 50mA)
<b>Current leakage when OFF</b>	0.1mA or less
<b>Pulse output units</b>	1,10,100,1k,5k,10k,50k,100kWh
<b>Pulse ON time</b>	500ms fixed

### Important

- The terminal panel is the push-in type. Also read "Cautions when connecting the Push-In Plus terminal (RS-485 communication terminal and pulse output terminal) (⇒ 34)" when wiring.
- Do not directly connect an external power source to OUT or COM. Make sure the load is connected.
- For wiring to the pulse output terminals, use 24 to 14 AWG (cross section surface area of 0.2 to 2.0mm<sup>2</sup>) electrical wire.
- Single wires, stranded wires, and ferrule terminals can be used. The recommended stripped wire length when using single wires or stranded wire is 8 to 10mm (however, 10mm must be used when using AWG14).
- To avoid the influence of noise, use separate wiring for the signals and for the power.
- Output for circuit A is allocated to OUT1, circuit B to OUT2, circuit C to OUT3, and circuit D to OUT4. These allocations are fixed.

### 2.5 Pulse output wiring (continued)

#### Cautions when connecting the Push-In Plus terminal (RS-485 communication terminal and pulse output terminal)

Follow the below steps when connecting the Push-In Plus terminal

##### 1 Connecting Wires to Push-In Plus Terminal Block

###### • Part Names of the Terminal Block

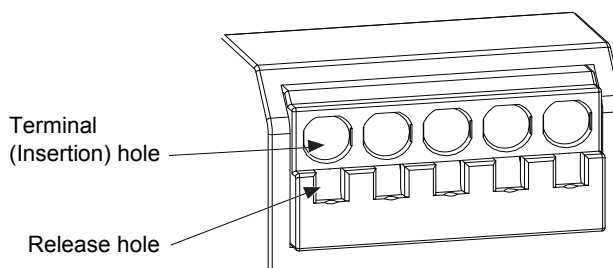

###### • Connecting Wires with Ferrules and Solid Wires

Insert the solid wire or ferrule straight into the terminal block until the end strikes the terminal block.

If a wire is difficult to connect because it is too thin, use a flat-blade screwdriver in the same way as when connecting stranded wire.

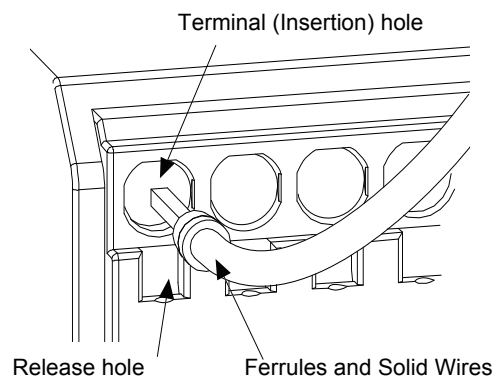

###### • Connecting Stranded Wires

Use the following procedure to connect the wires to the terminal block.

- 1 Hold a flat-blade screwdriver at an angle and insert it into the release hole. The angle should be between 10° and 12°. If the flat-blade screwdriver is inserted correctly, you will feel the spring in the release hole.
- 2 With the screwdriver still inserted into the release hole, insert the wire into the terminal hole until it strikes the terminal block.
- 3 Remove the flat-blade screwdriver from the release hole.

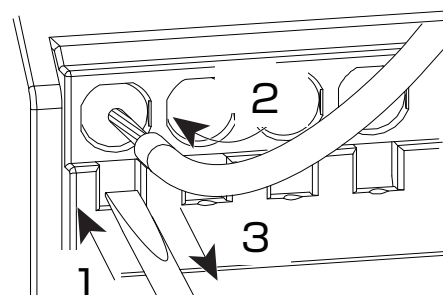
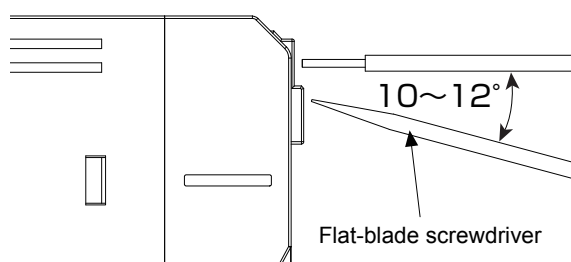

## 2.5 Pulse output wiring (continued)

### • Checking Connections

- After the insertion, pull gently on the wire to make sure that it will not come off and the wire is securely fastened to the terminal block.
- To prevent short circuits, insert the stripped part of a stranded or solid wire or the conductive part of a ferrule until it is hidden inside the terminal insertion hole. (See right diagram.)

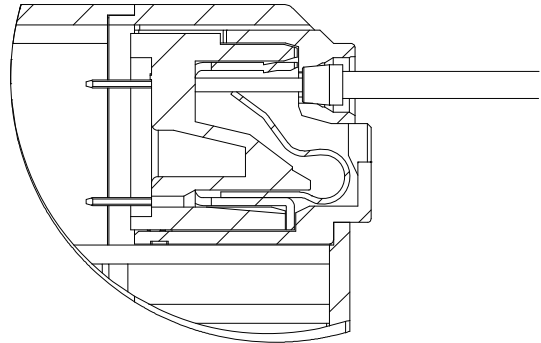

### 2 Removing Wires from Push-In Plus Terminal Block

Use the following procedure to remove wires from the terminal block. The same method is used to remove stranded wires, solid wires, and ferrules.

- 1 Hold a flat-blade screwdriver at an angle and insert it into the release hole.
- 2 With the screwdriver still inserted into the release hole, remove the wire from the terminal insertion hole.
- 3 Remove the flat-blade screwdriver from the release hole.

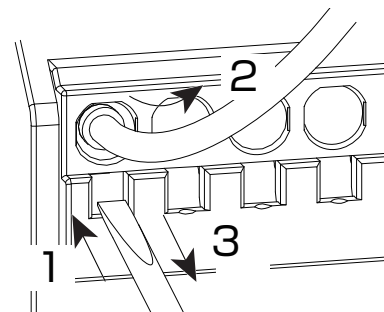
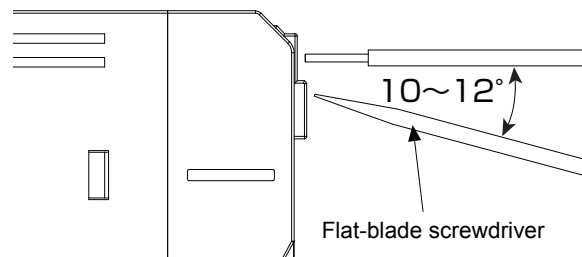

### 2 Removing Wires from Push-In Plus Terminal Block

#### • Recommended Flat-blade Screwdriver

Use a flat-blade screwdriver to connect and remove wires.

Use the following flat-blade screwdriver.

Model	Manufacturer
XW4Z-00B	Omron

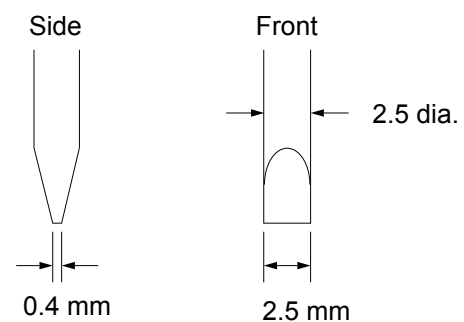

## 2.6 RS-485 wiring

Wire the RS-485 terminals if using the RS-485 communication feature. The layout of RS-485 terminals is as follows.

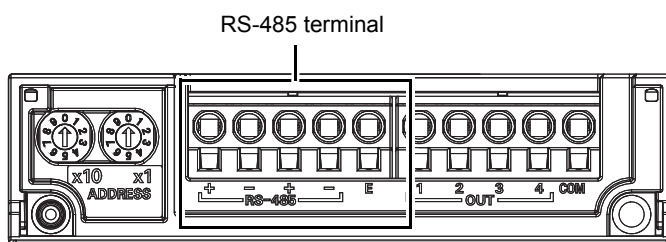

Terminal number	Terminal name	Description
1	RS-485+	+terminal for RS-485
2	RS-485-	-terminal for RS-485
3	RS-485+	RS-485+terminal (for crossover wiring)
4	RS-485-	RS-485-terminal (for crossover wiring)
5	RS-485 E	Terminating resistor for RS-485 (ON when shorted with terminal number 4)

Terminal number 1 and 3 and terminal number 2 and 4 are electrically connected inside this product. Push the wire to the very back of the RS-485 terminal while pressing on the release hole.

Refer to "Cautions when connecting the Push-In Plus terminal (RS-485 communication terminal and pulse output terminal)(⇒ 34)" for details about wiring and connections.

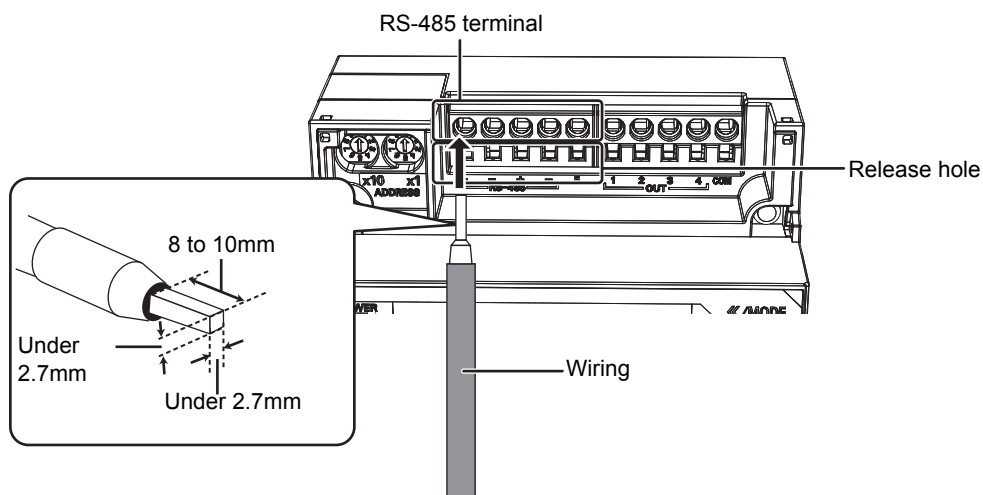

## 2.6 RS-485 wiring (continued)

The following diagram shows wiring for RS-485 communication.

The configuration of the connection should be either 1:1 or 1:N. If the 1:N connection is Modbus, up to 99 of this product can be connected. If CompoWay/F, up to 31 can be connected. Enable the terminating resistor that shorts terminal numbers 4 and 5 in the end unit.

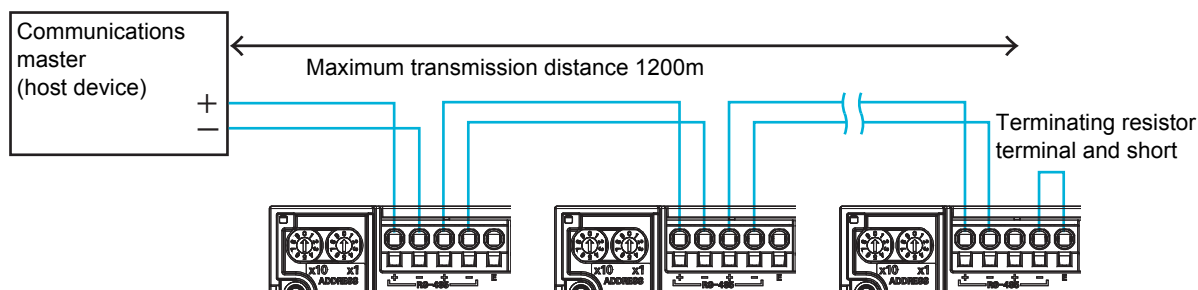

### Setting the communication address

When wiring is finished, turn the rotary switch to set the communication address.

The value on the left is circuit A communication address tens place and the value on the right is the ones.

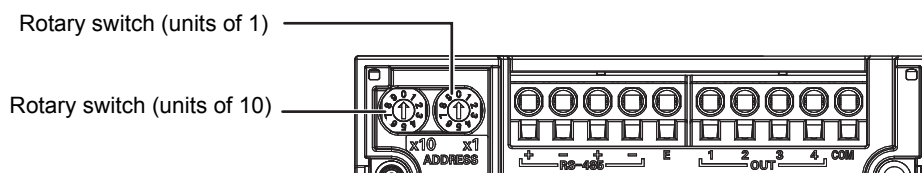

### Important

- The terminal panel is the push-in type. Also read "Cautions when connecting the Push-In Plus terminal (RS-485 communication terminal and pulse output terminal) (⇒ 34)" when wiring.
- Only the communication address for circuit A can be set with the rotary switch. Refer to "Settings for circuits B to D (when measuring 2 circuits or more)" (⇒ 56) to set the communications addresses for circuits B to D.
- The addresses for circuits B to D are automatically set, where 1 is added for each circuit in order to the address set for circuit A. Refer to "Settings for circuits B to D (when measuring 2 circuits or more) (⇒ 56)" for details.
- If the communications address exceeds 99 when multi-circuit metering, the value is invalid.
- If the host device you are using does not have its own built in terminating resistor, connect a terminating resistor to the host device. The terminating resistance is 120Ω (1/2W).
- Do not wire in a terminating resistor terminal on any of these products that are along the transmission path. This can cause communication failures.
- There is no FG terminal on this product. Connect only the + wire and – wire of RS-485.
- Use twisted pair cables.
- For wiring to the RS-485 terminals, use 24 to 14 AWG (cross section surface area of 0.2 to 2.0mm<sup>2</sup>) electrical wire.
- Single wires, stranded wires, and ferrule terminals can be used. The recommended stripped wire length when using single wires or stranded wire is 8 to 10mm (however, 10mm must be used when using AWG14).
- To avoid the influence of noise, use separate wiring for the RS-485 communications and for the power.
- Irrespective of the transmission distance and number of units connected, perform communications checks with the actual units.
- During use, make sure the terminal panel cover is closed.

### [Reference]

- If the upstream device does not support RS-485 communications, refer to the table below to select a converter for your purpose.

Protocol	KM-N Setting Tool	USB/RS-485 converter operability confirmed
Modbus	Yes	SI-35USB (LINEEYE Co., Ltd.)
	No	
CompoWay/F	Yes	K3SC-10 (Omron), SI-35USB (LINEEYE Co.,Ltd.)
	No	

## 2.7 Wiring diagrams

The below table shows the wiring for voltage, current, and CT by each phase and wire type.

### ■ For 3-phase 4-wire

3-phase 4-wire measures one circuit, as shown in the following diagram.

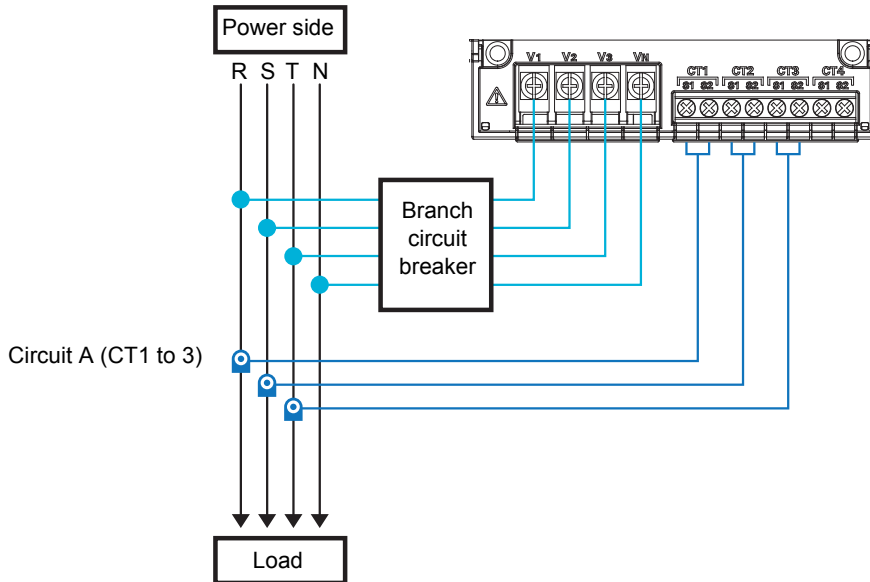

### ■ For 1-phase 2-wire

As shown below, 1-phase 2-wire can measure a maximum of 4 circuits. The CT must be attached to the L-phase.

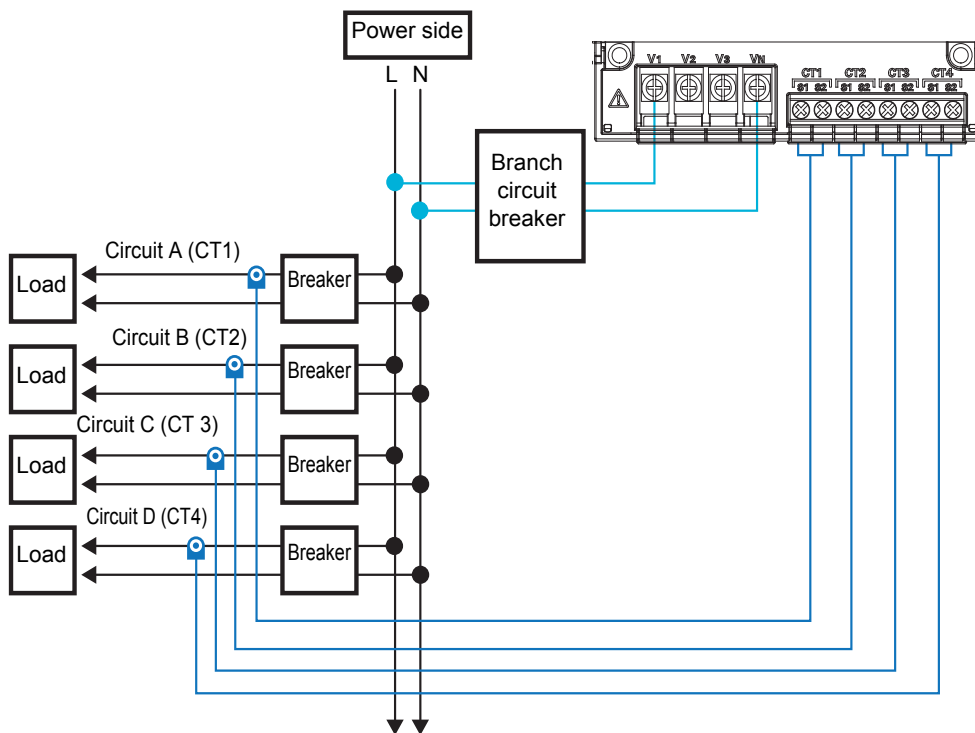

## 2.7 Wiring diagrams (continued)

### ■ For 1-phase 3-wire

As shown below, 1-phase 3-wire can measure a maximum of 2 circuits. Use CT1,CT2 when measuring only 1 circuit. The CT must be attached to the R-phase and the T-phase.

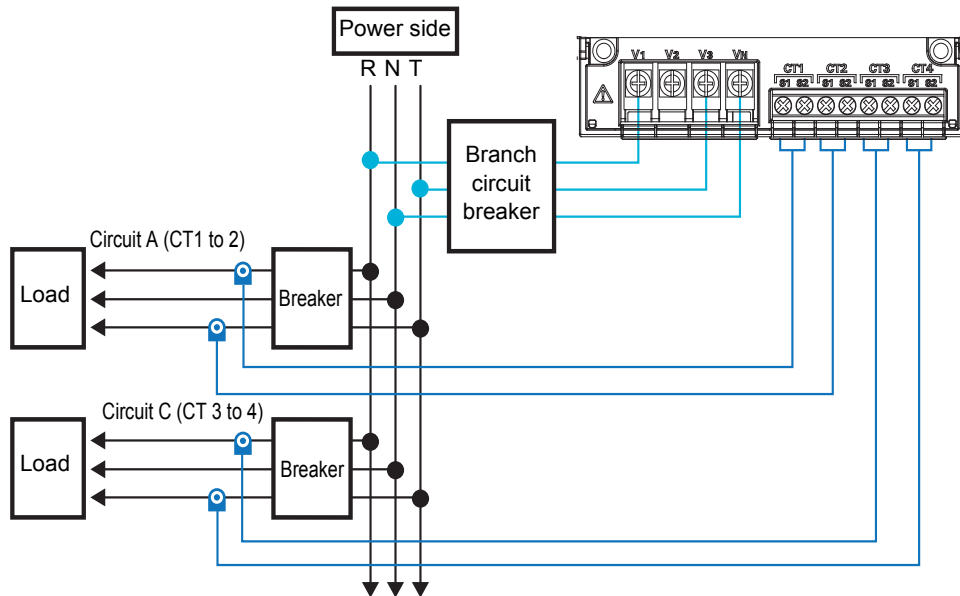

### ■ For 3-phase 3-wire

As shown below, 3-phase 3-wire can measure a maximum of 2 circuits. Use CT1,CT2 when measuring only 1 circuit. The CT must be attached to the R-phase and the T-phase.

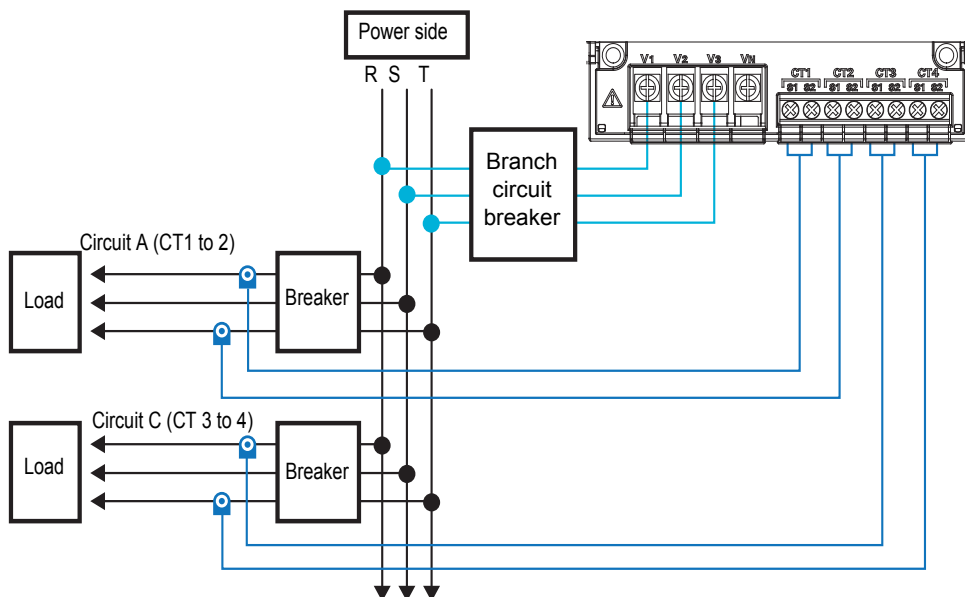

## 2.7 Wiring diagrams (continued)

The following wiring is also possible as a further method of measuring.

### ■ For 1-phase 2-wire voltage selected

The 1-phase 2-wire branching off from the 1-phase 3-wire is measured. With this connection, a setting is required according to which of R-N phase, T-N phase, or R-T phase is connected to the 1-phase 2-wire circuit. (⇒ 63) The CT must be attached to the R-phase or the T-phase.

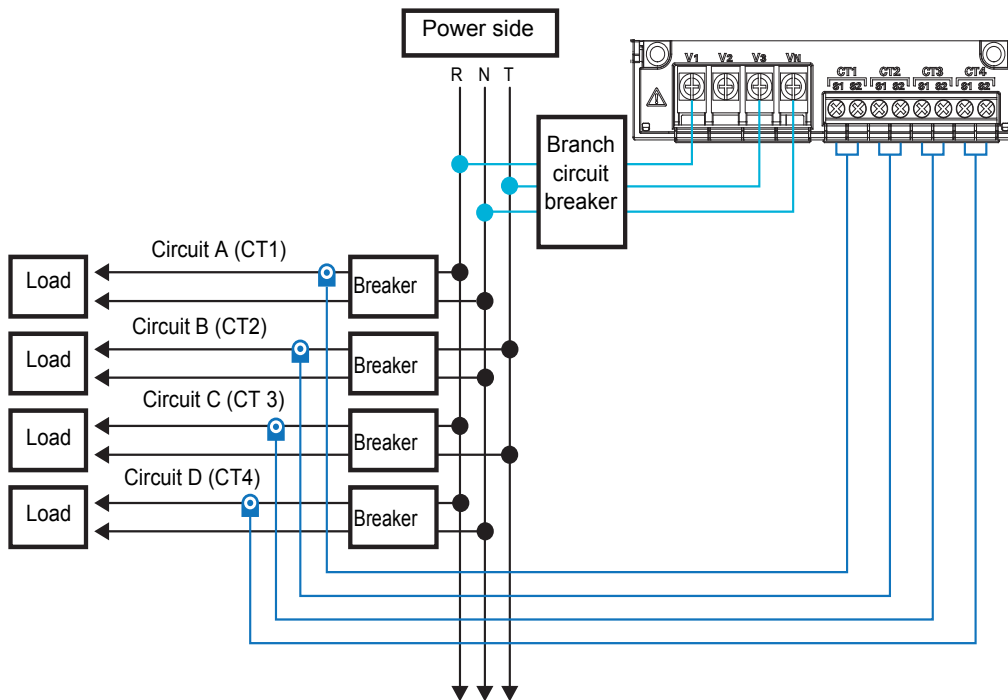

### ■ For 1-phase 3-wire composite

The 1-phase 3-wire circuit and the 1-phase 2-wire branching off from it are measured at the same time. With this connection, a setting is required according to which of R-N phase, T-N phase, or R-T phase is connected to the 1-phase 2-wire circuit. (⇒ 63) The 1-phase 2-wire circuit CT must be attached to the R-phase or the T-phase.

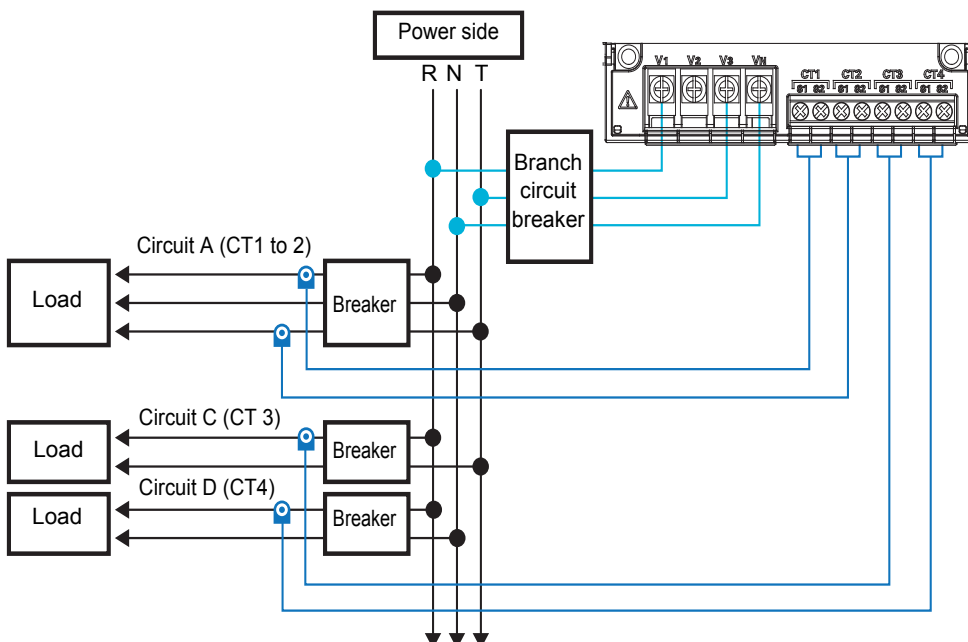

## 3.1 Turning the power on

### Important

- Before turning on the power, ensure that there are no problems with the wiring.

Turn the branch circuit breaker on and then turn this product on.

- The software version is shown on the main display, the model number "KM-N2" is shown on the sub-display, and all of the LEDs light.
- After this, the measuring mode is moved to automatically and the active energy (import) (kWh) for circuit A is displayed.

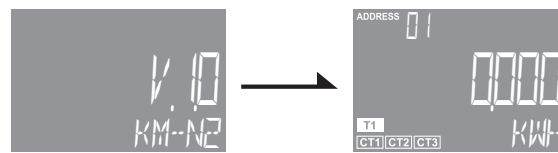
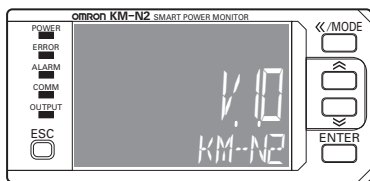

(Example of Ver.1.0.X)

## 3.2 Switching between modes

### Switching between the measuring mode and the setting mode

Switch between the measuring mode and setting mode by pressing and holding the [←/MODE] key.

- "Press and hold" means pressing the key for 1 or more seconds.

#### ■ Measuring mode → Setting mode

- Screen to enter the password
- Enter password (password authentication OK)
- "SET MODE" displayed → Setting mode

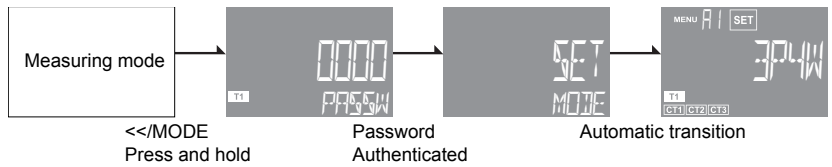

#### ■ Setting mode → Measuring mode

- ① If settings are not changed in the setting mode "MEASR MODE" displayed → Measuring mode
- ② If settings are changed in the setting mode "SAVE" display → restart → Measuring mode – Restarting is done automatically.

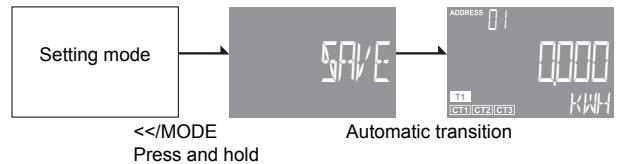
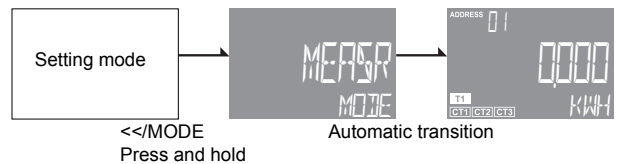

### Switching between the measuring mode and the communication setting mode

You can switch between the communication setting mode and the measuring mode by sending particular commands. Refer to "6.Detailed settings for communications (⇒ 74)" for details about the commands to move to each mode.

#### ■ Switching from measuring mode to communication setting mode

- Command sent → "COMM MODE" displayed ("COMM MODE" is displayed while in communication setting mode)

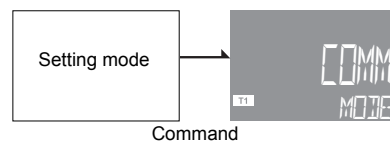

#### ■ Switching from communication setting mode to measuring mode

- Command sent → "MEASR MODE" displayed → Measuring mode
- ① If settings are not changed in the communication setting mode "MEASR MODE" displayed → Measuring mode
- ② If settings are changed in the communication setting mode "SAVE" displayed → restart → Measuring mode – Restarting is done automatically.

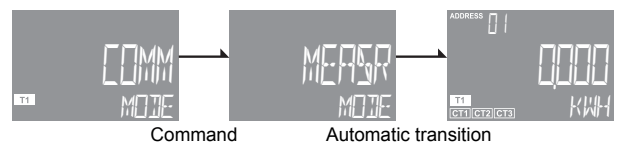

## 3.2 Switching between modes (continued)

### Switching between the setting mode and the communication setting mode

You can switch between the setting mode and the communication setting mode by sending particular commands. Refer to "6.Detailed settings for communications (⇒ 74)" for details about the commands.

It is not possible to move from the communication setting mode to the setting mode.

#### ■ Switching from the setting mode to the communication setting mode

Command sent → "COMM MODE" displayed

("COMM MODE" is displayed while in communication setting mode)

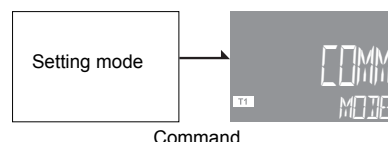

### How to enter the password

- When moving from the measuring mode to the setting mode, you need to enter the password that has been set.
- The default password is "0001".
- You can set a password of 4 numerals between 0000 and 9999. Change the password as necessary. (5.7Change password (⇒ 70))

#### ■ Enter the password (Ex.: enter password "3060")

- ① Enter "3060" with the [↵][⇐] keys in the password entry screen.
  - Press the [⇐/MODE] key to move one place to the left.
  - If you press the [⇐/MODE] key on the end at the left, the cursor moves to the right end.
- ② The password is verified when you press the [ENTER] key and "OK" is displayed. After this, the transition to setting mode is automatic.



"NG" is displayed if the password you entered was wrong. Reenter the password.



# 3.3 How to read the measurements

The measurements are shown for circuits A to D in the measuring mode. Depending on the phase and wire type selected, the display changes as follows.

The parts in broken lines (circuits B to D) are displayed if you have enabled the circuit settings (⇒ 56).

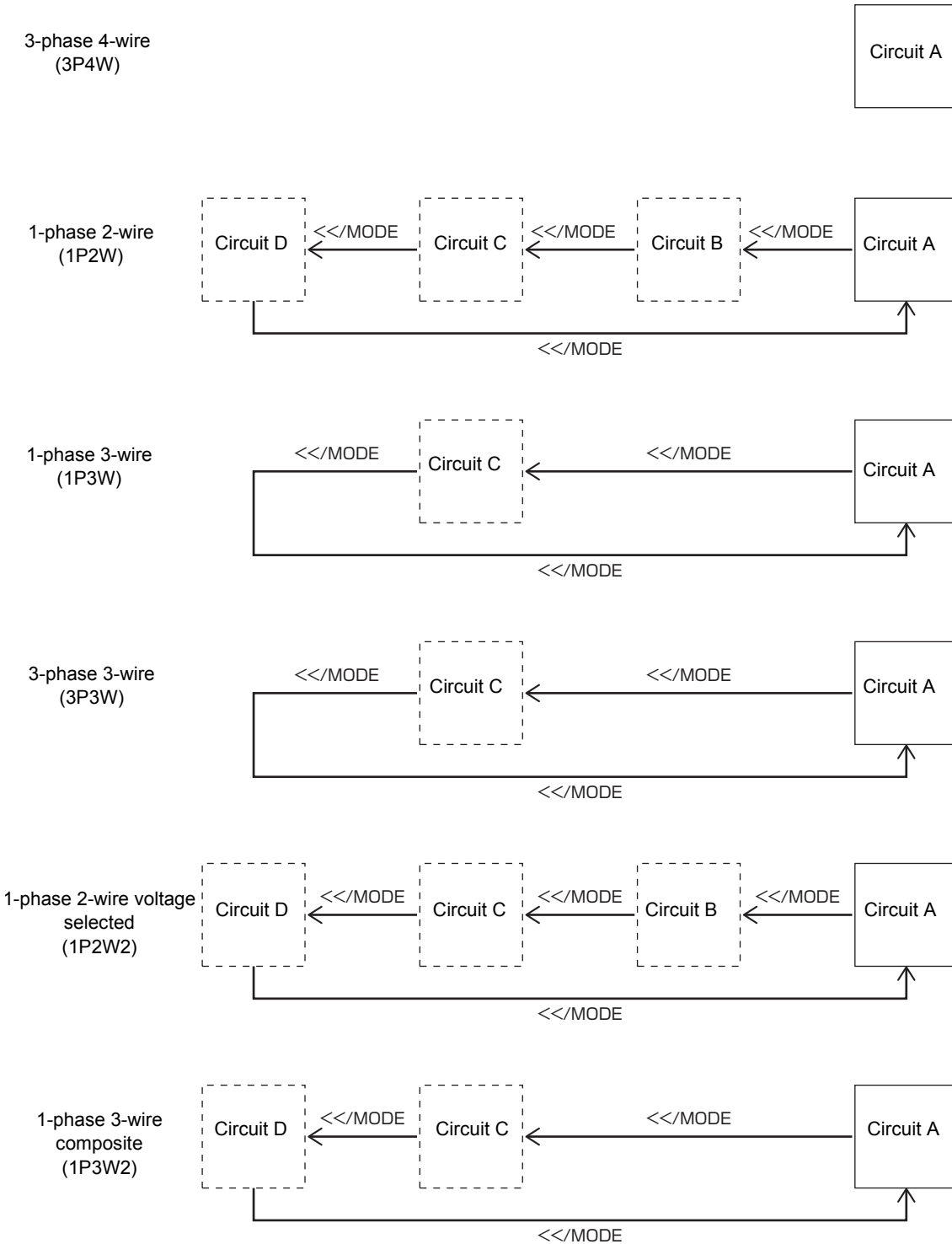

## 3.3 How to read the measurements (continued)

### ● Switching circuits

Press the [◀/MODE] key to switch the circuit displayed. The measuring items are displayed after the screen for showing the destination circuit.

- The measuring items for circuits B to D are displayed when the circuit settings are enabled (ON).
- With 3P4W, only circuit A is displayed. With 1P3W and 3P3W, only circuits A and C are displayed.
- Press the [↗][↘] keys to switch the items measured.

(Display example for 1-phase 2-wire (1P2W))

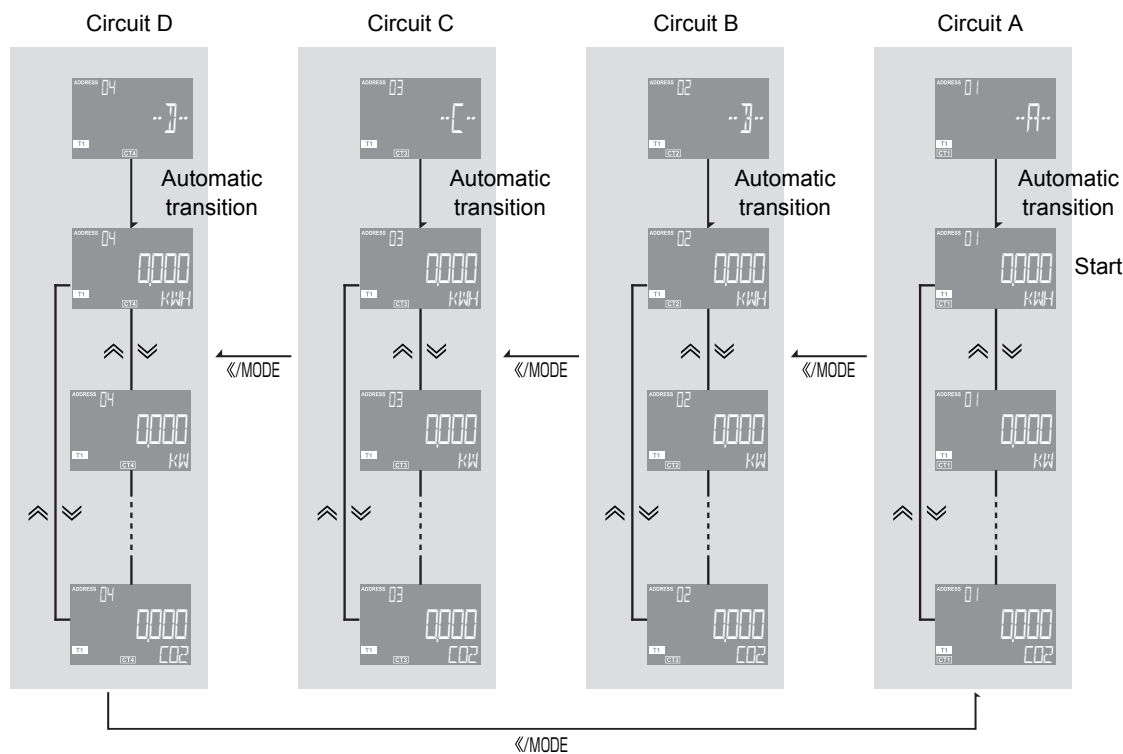

### ● Switching the measured values display

Press the [↗][↘] keys to switch the items measured. Depending on the phase and wire type, some items are not displayed.

- Refer to "Measurement display list (⇒ 46)" for details about measuring items.

#### ■ Display of CTs used

The measurements are shown for each of the circuits in the measuring mode. The CTs being used by each circuit are displayed in the display of CTs used at this time.

For example, for 1-phase 3-wire or 3-phase 3-wire, the measurement display for circuit A also displays CT1 and CT2 as shown at right.

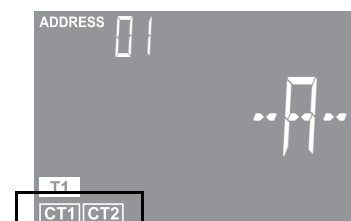

### 3.3 How to read the measurements (continued)

#### ■ Measurement display list

Order of display	Item	Main display/numerals	Sub display/units	Remarks
1	Active energy (import)	0.000 to 999999.999	KWH	Units automatically switch*
		1000.000 to 999999.999	MWH	
2	Active power	-99999.999 to 999999.999	KW	
3	Current 1	0.000 to 999999.999	$I_{LR}$ : 3-phase 4-wire	
			$I$ : 1-phase 2-wire	
			$I_{LN}$ : 1-phase 3-wire	
			$I_{LR}$ : 3-phase 3-wire	
			$I$ : 1-phase 2-wire voltage selected	
			$I$ (Circuit A only $I_{LN}$ ) : 1-phase 3-wire composite	
4	Current 2	0.000 to 999999.999	$I_{LS}$ : 3-phase 4-wire	
			None : 1-phase 2-wire	
			$I_{LN}$ : 1-phase 3-wire	
			$I_{LS}$ : 3-phase 3-wire	
			None : 1-phase 2-wire voltage selected	
			None (Circuit A only $I_{LN}$ ) : 1-phase 3-wire composite	
5	Current 3	0.000 to 999999.999	$I_{LT}$ : 3-phase 4-wire	
			None : 1-phase 2-wire voltage selected	
			$I_{LT}$ : 1-phase 3-wire	
			$I_{LT}$ : 3-phase 3-wire	
			None : 1-phase 2-wire voltage selected	
			None (Circuit A only $I_{LT}$ ) : 1-phase 3-wire composite	
6	Phase voltage 1	0.0 to 99999999.9	$V_{LR}$ : 3-phase 4-wire	*1 Varies according to the voltage assignment settings *2 Varies according to the voltage assignment settings
			$V$ : 1-phase 2-wire	
			$V_{LN}$ : 1-phase 3-wire	
			None : 3-phase 3-wire	
			$V_{LR}, V_{LT}, V_{LR-T}$ *1 : 1-phase 2-wire voltage selected	
			$V_{LR}, V_{LT}, V_{LR-T}$ (Circuit A only $V_{LN}$ )*2 : 1-phase 3-wire composite	
7	Phase voltage 2	0.0 to 99999999.9	$V_{LS}$ : 3-phase 4-wire	
			None : 1-phase 2-wire	
			None : 1-phase 3-wire	
			None : 3-phase 3-wire	
			None : 1-phase 2-wire voltage selected	
			None : 1-phase 3-wire composite	
8	Phase voltage 3	0.0 to 99999999.9	$V_{LT}$ : 3-phase 4-wire	
			None : 1-phase 2-wire	
			$V_{LT}$ : 1-phase 3-wire	
			None : 3-phase 3-wire	
			None : 1-phase 2-wire voltage selected	
			None (Circuit A only $V_{LT}$ ) : 1-phase 3-wire composite	

\* The units change automatically the maximum value is reached, with the display value on the unit returning to 0, but recording continues. Accurate values can be obtained by using the communication function.

### 3.3 How to read the measurements (continued)

Order of display	Item	Main display/numerals	Sub display/units	Remarks
9	Inter-wire voltage 1	0.0 to 99999999.9	$V_{R-S}$ : 3-phase 4-wire	
			None : 1-phase 2-wire	
			None : 1-phase 3-wire	
			$V_{R-T}$ : 3-phase 3-wire	
			None : 1-phase 2-wire voltage selected	
			None : 1-phase 3-wire composite	
10	Inter-wire voltage 2	0.0 to 99999999.9	$V_{R-T}$ : 3-phase 4-wire	
			None : 1-phase 2-wire	
			$V_{R-S}$ : 1-phase 3-wire	
			$V_{R-T}$ : 3-phase 3-wire	
			None : 1-phase 2-wire voltage selected	
			None (Circuit A only $V_{R-S}$ ) : 1-phase 3-wire composite	
11	Inter-wire voltage 3	0.0 to 99999999.9	$V_{S-T}$ : 3-phase 4-wire	
			None : 1-phase 2-wire	
			None : 1-phase 3-wire	
			$V_{S-T}$ : 3-phase 3-wire	
			None : 1-phase 2-wire voltage selected	
			None : 1-phase 3-wire composite	
12	Frequency	45.0 to 65.0	Hz	
13	Power factor	-1.00 to 1.00	PF	
14	Reactive power	-99999.999 to 999999.999	kVAr	
15	Active energy (export)	0.000 to 999999.999	-kWh	Units automatically switch*
		1000.000 to 999999.999	-MWh	
16	Cumulative total reactive power	0.000 to 999999.999	kVArh	Units automatically switch*
		1000.000 to 999999.999	MVArh	
17	Reactive energy (import)	0.000 to 999999.999	-kVArh	Units automatically switch*
		1000.000 to 999999.999	-MVArh	
18	Reactive energy (export)	0.000 to 999999.999	±kVArh	Units automatically switch*
		1000.000 to 999999.999	±MVArh	
19	T1 Active energy (import)	0.000 to 999999.999	kWh	Units automatically switch*
		1000.000 to 999999.999	MWh	
20	T2 Active energy (import)	0.000 to 999999.999	kWh	Units automatically switch*
		1000.000 to 999999.999	MWh	
21	T3 Active energy (import)	0.000 to 999999.999	kWh	Units automatically switch*
		1000.000 to 999999.999	MWh	
22	T4 Active energy (import)	0.000 to 999999.999	kWh	Units automatically switch*
		1000.000 to 999999.999	MWh	

\* The units change automatically the maximum value is reached, with the display value on the unit returning to 0, but recording continues. Accurate values can be obtained by using the communication function.

## 3.3 How to read the measurements (continued)

Order of display	Item	Main display/numerals	Sub display/units	Remarks
23	Active energy (import) (resettable)	0.000 to 999999.999	KWH (flashes)	Units automatically switch*
		1000.000 to 999999.999	MWH (flashes)	
24	Active energy (export) (resettable)	0.000 to 999999.999	--KWH (flashes)	Units automatically switch*
		1000.000 to 999999.999	--MWH (flashes)	
25	Cumulative total reactive power (resettable)	0.000 to 999999.999	KVARH (flashes)	Units automatically switch*
		1000.000 to 999999.999	MVARH (flashes)	
26	Reactive energy (import) (resettable)	0.000 to 999999.999	--KVARH (flashes)	Units automatically switch*
		1000.000 to 999999.999	--MVARH (flashes)	
27	Reactive energy (export) (resettable)	0.000 to 999999.999	÷KVARH (flashes)	Units automatically switch*
		1000.000 to 999999.999	÷MVARH (flashes)	
28	T1 Active energy (import) (resettable)	0.000 to 999999.999	KWH (flashes)	Units automatically switch*
		1000.000 to 999999.999	MWH (flashes)	
29	T2 Active energy (import) (resettable)	0.000 to 999999.999	KWH (flashes)	Units automatically switch*
		1000.000 to 999999.999	MWH (flashes)	
30	T3 Active energy (import) (resettable)	0.000 to 999999.999	KWH (flashes)	Units automatically switch*
		1000.000 to 999999.999	MWH (flashes)	
31	T4 Active energy (import) (resettable)	0.000 to 999999.999	KWH (flashes)	Units automatically switch*
		1000.000 to 999999.999	MWH (flashes)	
32	Conversion value	0.000 to 999999.999	X X X (Setting can be changed)	Units automatically switch*
		1000.000 to 999999.999	K X X X (Setting can be changed)	
		1000.000 to 999999.999	M X X X (Setting can be changed)	

\* The units change automatically the maximum value is reached, with the display value on the unit returning to 0, but recording continues. Accurate values can be obtained by using the communication function.

## 3.4 How to read the setting values

The setting mode is organized into the categories "Individual setting items for circuits A to D", "Common settings", and "Other settings".

Category	Description
Circuits (A, B, C, D)	Individual setting items for the circuits
Common (CMMN)	Setting items common to all of the circuits (communication, pulse output, etc.)
Others (ETC)	Settings for initializing, resetting cumulative values, etc.

Depending on the phase and wire type selected, the displayed settings change as follows. The setting items for circuits in the broken lines are displayed if you have enabled the circuits.

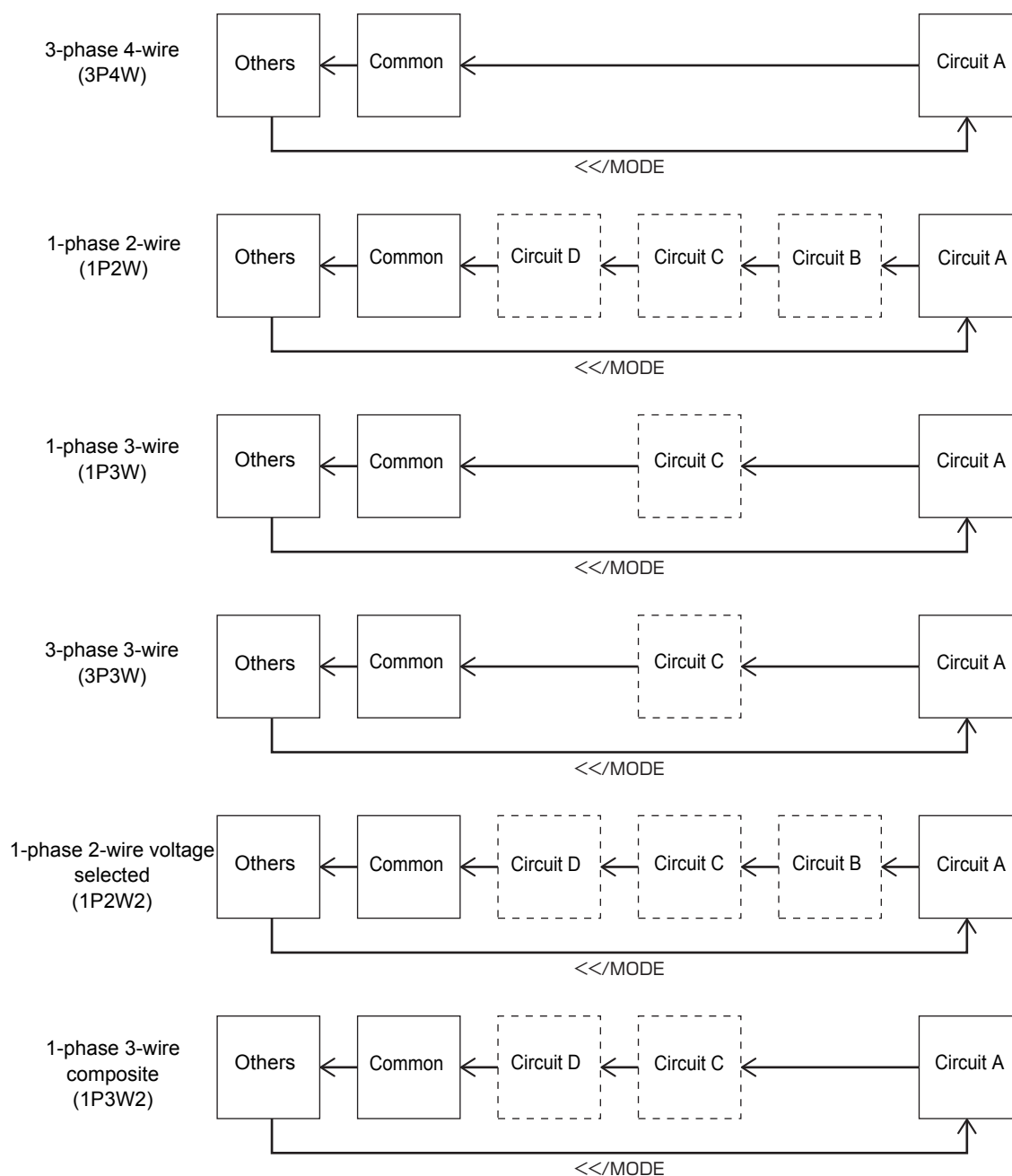

### 3.4 How to read the setting values (continued)

#### ● How to switch setting items

When the [◀/MODE] key is pressed, the setting items are displayed after the screen for showing the destination circuit.

- The setting items for circuits B to D are displayed when the circuit settings are enabled (ON).
- Press the [⏴][⏵] keys to switch the setting items.
- Refer to "Setting item list (⇒ 51)" for details about all of the setting items.

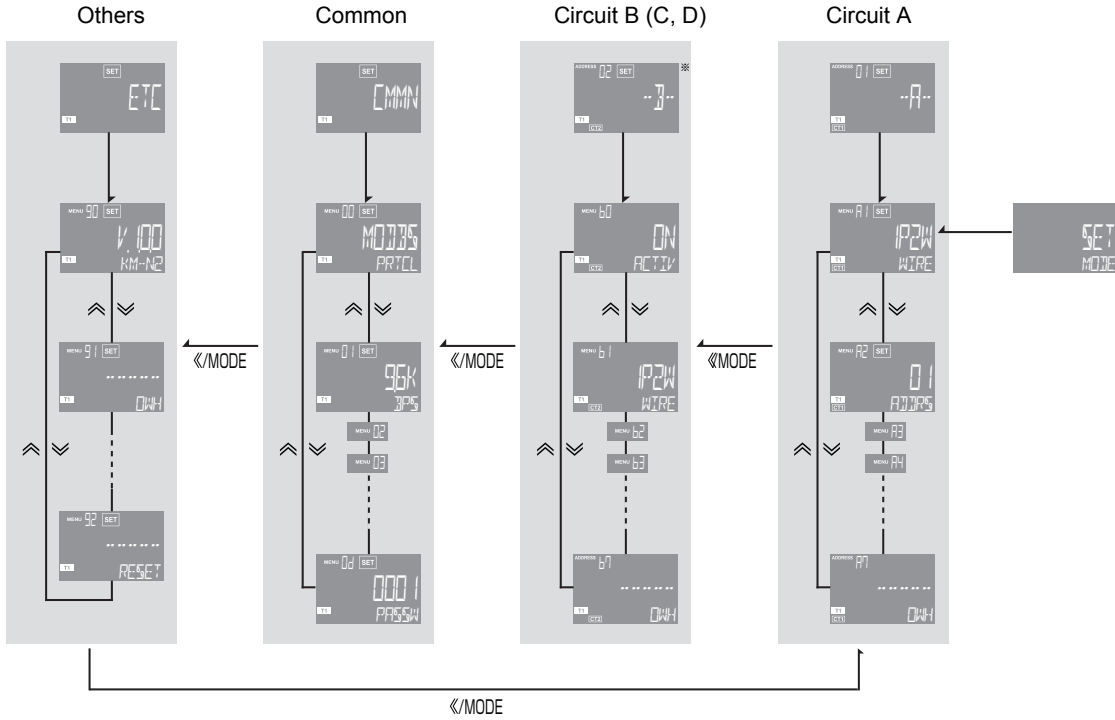

\* For circuit C the MENU No. are c0, c1, c2, c3, ... c7  
 For circuit D the MENU No. are d0, d1, d2, d3, ... d7

## 3.4 How to read the setting values (continued)

### ■ Setting item list

Category	MENU No.	Setting Item	Main display Display of options and input values	Sub display Unit	Default Value	Remarks
Circuit A	A1	Phase and wire type	3P4W / 1P2W / 1P3W / 3P3W / 1P2W2 / 1P3W2	WIRE	3P4W	3P4W: 3-phase 4-wire, 1P2W: 1-phase 2-wire 1P3W: 1-phase 3-wire, 3P3W: 3-phase 3-wire 1P2W2: 1-phase 2-wire voltage selected 1P3W2: 1-phase 3-wire composite
	A2	Communication address*	Modbus : --, 01 to 99, CompoWay/F : -- 00 to 99,	ADDRS	-- (invalid value)	Set a different number for each circuit.
	A3	CT secondary side current	1A / 5A	CT2ND	5A	Set to match the rating of the CT to be used.
	A4	CT primary side current	1 to 99999	CT1ST	5	Rated values for the primary side of the CT to be connected. Set CT individually.
	A5	Voltage assignment	V_R / V_T / V_R-T	V-SET	V_R	Set the voltage phase for 1-phase 2-wire circuits when 1P2W2 is selected.
	A6	Pulse output ON/OFF	ON / OFF	OUT	OFF	
	A7	Active energy reset	----	0WH	----	Clear the active energy for the circuit.
Circuit B	B0	Circuit B ON/OFF	ON / OFF	ACTIV	OFF	ON: Circuit enabled, measuring and setting possible. OFF: Circuit disabled, measuring and setting not possible.
	B1	Phase and wire type	3P4W / 1P2W / 1P3W / 3P3W / 1P2W2 / 1P3W2	WIRE	--	Phase and wire type set in MENU No. A1
	B2	Communication address*	Modbus : --, 01 to 99, CompoWay/F : -- 00 to 99,	ADDRS	-- (invalid value)	Set a different number for each circuit.
	B3	CT secondary side current	1A / 5A	CT2ND	5A	Set to match the rating of the CT to be used.
	B4	CT primary side current	1 to 9999	CT1ST	5	Rated values for the primary side of the CT to be connected. Set CT individually.
	B5	Voltage assignment	V_R / V_T / V_R-T	V-SET	V_R	Set the voltage phase for 1-phase 2-wire circuits when 1P2W2 is selected.
	B6	Pulse output ON/OFF	ON / OFF	OUT	OFF	
B7	Active energy reset	----	0WH	----	Clear the active energy for the circuit.	
Circuit C	C0	Circuit C ON/OFF	ON / OFF	ACTIV	OFF	ON: Circuit enabled, measuring and setting possible. OFF: Circuit disabled, measuring and setting not possible.
	C1	Phase and wire type	3P4W / 1P2W / 1P3W / 3P3W / 1P2W2 / 1P3W2	WIRE	--	Phase and wire type set in MENU No. A1
	C2	Communication address*	Modbus : --, 01 to 99, CompoWay/F : -- 00 to 99,	ADDRS	-- (invalid value)	Set a different number for each circuit.
	C3	CT secondary side current	1A / 5A	CT2ND	5A	Set to match the rating of the CT to be used.
	C4	CT primary side current	1 to 99999	CT1ST	5	Set CT individually.
	C5	Voltage assignment	V_R / V_T / V_R-T	V-SET	V_R	Set the voltage phase for 1-phase 2-wire circuits when 1P2W2 or 1P3W2 is selected.
	C6	Pulse output ON/OFF	ON / OFF	OUT	OFF	
C7	Active energy reset	----	0WH	----	Clear the active energy for the circuit.	
Circuit D	D0	Circuit D ON/OFF	ON / OFF	ACTIV	OFF	ON: Circuit enabled, measuring and setting possible. OFF: Circuit disabled, measuring and setting not possible.
	D1	Phase and wire type	3P4W / 1P2W / 1P3W / 3P3W / 1P2W2 / 1P3W2	WIRE	--	Phase and wire type set in MENU No. A1
	D2	Communication address*	Modbus : --, 01 to 99, CompoWay/F : -- 00 to 99,	ADDRS	-- (invalid value)	Set a different number for each circuit.
	D3	CT secondary side current	1A / 5A	CT2ND	5A	Set to match the rating of the CT to be used.
	D4	CT primary side current	1 to 99999	CT1ST	5	Set CT individually.
	D5	Voltage assignment	V_R / V_T / V_R-T	V-SET	V_R	Set the voltage phase for 1-phase 2-wire circuits when 1P2W2 or 1P3W2 is selected.
	D6	Pulse output ON/OFF	ON / OFF	OUT	OFF	
D7	Active energy reset	----	0WH	----	Clear the active energy for the circuit.	

\* The communication address can only be set using the rotary switch. You cannot set it with the [↵] and [↶] keys.

## 3.4 How to read the setting values (continued)

Circuit	MENU No.	Setting Item	Main display Display of options and input values	Sub display Unit	Default Value	Remarks
Comm on CMMN	00	Protocol	MODBS / COMPF	PRTCL	MODBS	
	01	Communication speed	1.2K / 2.4K / 4.8K 9.6K / 19.2K / 38.4K(bps)	BPS	9.6K	
	02	Data length	7 / 8	LNGLH	8	Modbus: 8 (fixed) CompoWay/F: Select between 7 or 8
	03	Stop bit	1 / 2	STOP	1	
	04	Parity	NONE / ODD / EVEN	PRTY	EVEN	
	05	Transmission wait time	00 to 99	WAIT	20	
	06	VT ratio	1.00 to 999.99	VT-R	1.00	Set the ratio between the primary voltage and the secondary voltage when voltage using VT is input
	07	Conversion rate	0.000 to 99.999	RATE	10.000	Set the conversion factor by which active energy is multiplied for each circuit
	08	Conversion display units	3 places: XXX Each place: 0 to 9, A to Z, /, -, _	CHAR	CO2	Set the units for the conversion value using any 3 characters
	09	Pulse output units	1 / 10 / 100 / 1K / 5K 10K / 50K / 100K (Wh)	WH/P	100	
	0A	Automatic LCD off	OFF / 1.0 / 5.0 / 10.0 (minutes)	DISP	5.0	OFF means alight constantly
	0B	Warning ON/OFF	ON / OFF	ALARM	ON	Set the output for the warning for voltage miss-wiring (Output even when pulse output warning is OFF)
	0C	Tariff ON/OFF	ON / OFF	TARIF	ON	
0D	Change password	0000 to 9999	PASSW	0001	Change the password used when making settings.	
Others ETC	90	Software version display	V.1.0.0	KM-N2	---	The main display shows an example when the version is 1.0.0.
	91	All active energy reset	----	0WH	----	Clear the active energy for all circuits.
	92	Initialize	----	RESET	----	Restore the factory defaults. All settings and all measured values are initialized.

## 4.1 Setting items for measuring electricity

The following are the setting items for measuring electricity.

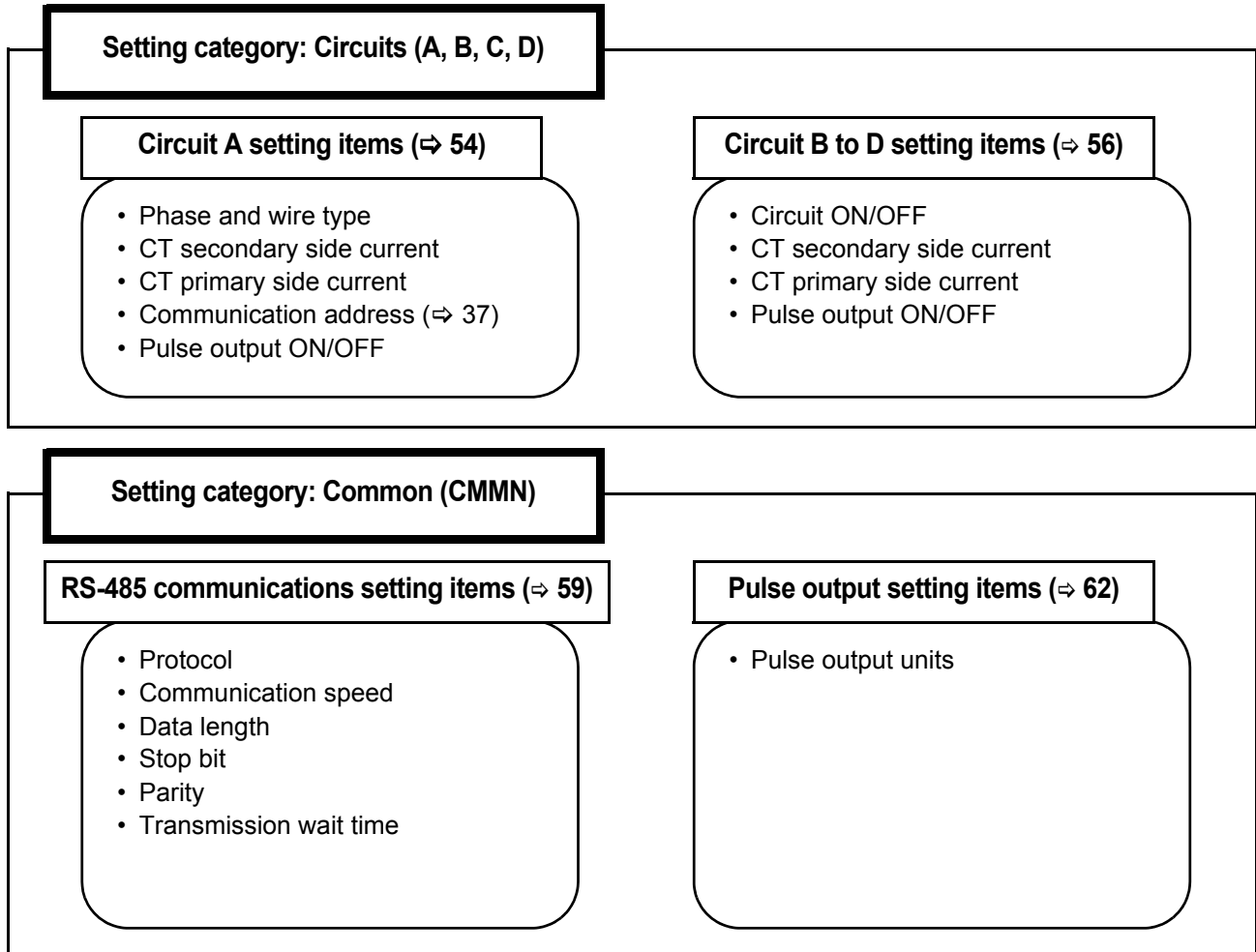

# 4.2 Circuit settings

Correct measurement requires the correct settings for phase and wire type, CT secondary side, and CT primary side. If points of measurement are added, enable the use of circuits B to D and set them.

## ● Circuit A settings

The following are the setting items required for measuring with circuit A.

When RS-485 communication is to be used, set the communication address beforehand (⇒ 37).

You can cancel a change by pressing the [ESC] key before confirming the change.

### 1 Moving to setting mode

- ① After turning on the power, the measuring mode is moved to automatically and the active energy (import) for circuit A is displayed.
- ② Press and hold the [←/MODE] key to move from the measuring mode to the password entry screen.
- ③ Press the [↵][⇐] keys and enter the password "0001 (default value)".
  - Press the [←/MODE] key to move one place to the left.
  - If you press the [←/MODE] key on the end at the left, the cursor moves to the right end.
- ④ The password is verified when you press the [ENTER] key and "OK" is displayed.
- ⑤ The screen then moves to the settings mode and the "SET MODE" screen is shown for about 1 second. After the "SET MODE" screen is shown for about 1 second, the screen moves to the settings category display screen for circuit A.

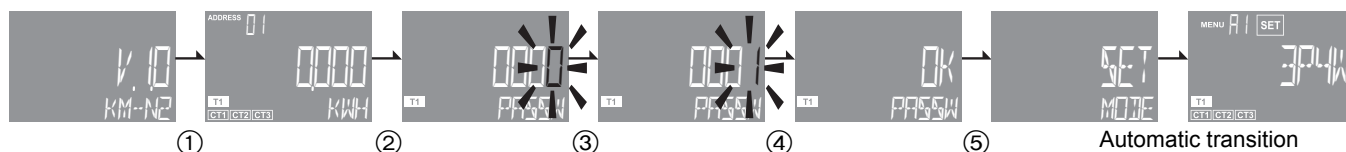

### 2 Set the phase and wire type (Ex.; set to 1-phase 3-wire)

- ① Transition from the settings category display screen for circuit A to the settings for circuit A is automatic. "Phase and wire type (MENU A1)" is displayed.
- ② Press the [ENTER] key to enter the setting mode. The setting value in the main display flashes.
- ③ Press the [↵][⇐] keys to select "1P3W" (1-phase 3-wire).
- ④ Press the [ENTER] key to confirm your selection.

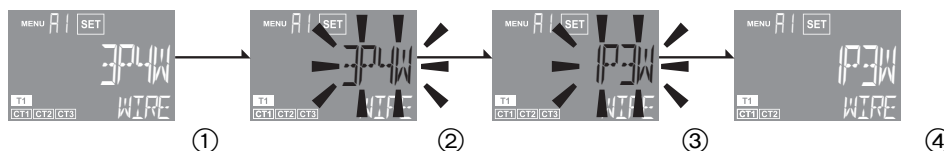

#### Caution

When the phase and wire type is changed, the enable/disable settings for circuits B to D are switched to "OFF" (disabled).

## 4.2 Circuit settings (continued)

### 3 Set the CT secondary side current (Ex.: set to 1A)

- ① From the circuit A setting item, press the [↵][⇐] keys to move to "CT secondary current (MENU A3)".
- ② Press the [ENTER] key to enter the setting mode. The setting value in the main display flashes.
- ③ Press the [↵][⇐] keys to select "1A".
- ④ Press the [ENTER] key to confirm your selection.

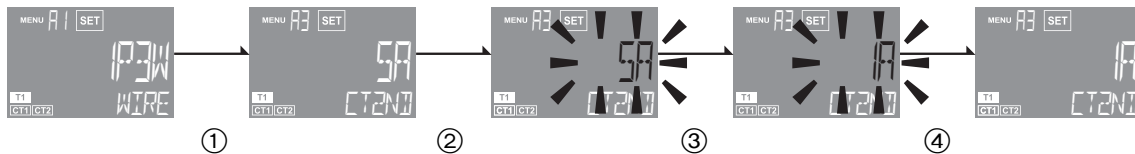

### 4 Set the CT primary side current (Ex.: set to 50A)

- ① From the circuit A setting item, press the [↵][⇐] keys to move to "CT primary current (MENU A4)".
- ② Press the [ENTER] key to enter the setting mode.
- ③ Press the [↵][⇐] keys to change the value to "50".
  - Press the [←/MODE] key to move one place to the left.
  - If you press the [←/MODE] key on the end at the left, the cursor moves to the right end.
- ④ Press the [ENTER] key to confirm your change.

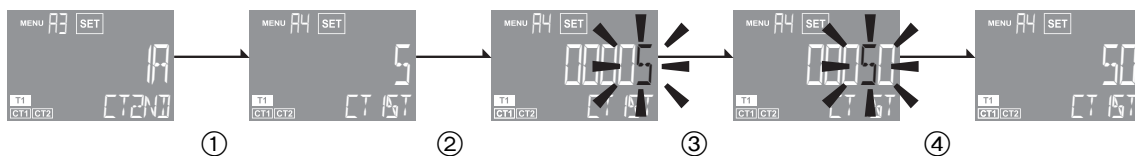

### 5 Set pulse output ON or OFF (MENU A6) (Ex.: set to ON)

- ① From the circuit A setting item, press the [↵][⇐] keys to move to "Pulse output ON/OFF (MENU A6)".
- ② Press the [ENTER] key to enter the setting mode.
- ③ Press the [↵][⇐] keys to select "ON".
- ④ Press the [ENTER] key to confirm your selection.

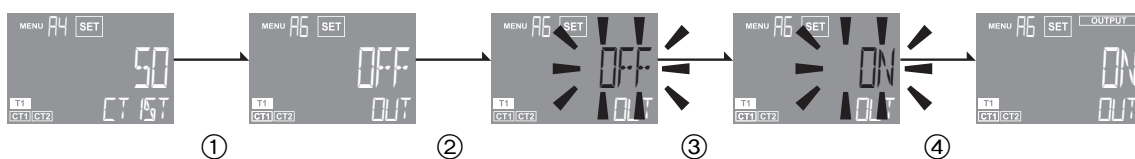

## 4.2 Circuit settings (continued)

### ● Settings for circuits B to D (when measuring 2 circuits or more)

This product can measure up to 4 circuits. If you increase the number of circuits, you must enable the circuits and set the items for them. (⇒ 21) Make sure you disable those circuits you are not using.

You cannot set the communications addresses for circuits B to D individually. The values are automatically set as follows according to the value on the rotary switch.

Phase and wire type	Communication address			
	Circuit A	Circuit B	Circuit C	Circuit D
3-phase 4-wire	Value set on the rotary switch	—	—	—
1-phase 2-wire		(Value of Circuit A + 1)	(Value of Circuit A + 2)	(Value of Circuit A + 3)
1-phase 3-wire		—	(Value of Circuit A + 1)	—
3-phase 3-wire		—	(Value of Circuit A + 1)	—
1-phase 2-wire voltage selected		(Value of Circuit A + 1)	(Value of Circuit A + 2)	(Value of Circuit A + 3)
1-phase 3-wire composite		—	(Value of Circuit A + 1)	(Value of Circuit A + 2)

#### Caution

- If the communications address exceeds 99 when multi-circuit metering, the value is invalid.

## 4.2 Circuit settings (continued)

### 1 Enable just those circuits from B to D that will be used (Ex.: enable circuit C)

If a measured value is displayed, press and hold the [←/MODE] key and enter your password to switch to the setting mode.

- ① Press the [←/MODE] key to move to the settings category display screen for circuit C.  
"Circuit C ON/OFF (MENU C0)" is displayed.
- ② Press the [ENTER] key to enter the setting mode.
- ③ Press the [↵][⇩] keys to select "ON".
- ④ Press the [ENTER] key to confirm your selection.

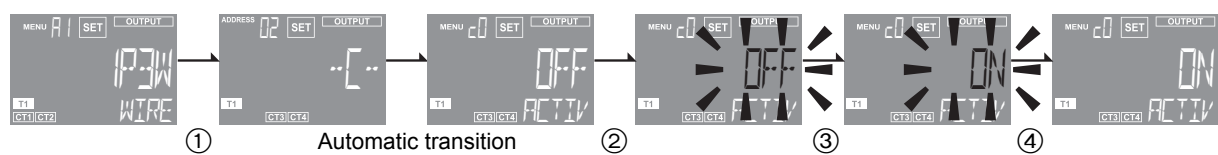

### 2 Set the CT secondary current for the circuits enabled from B to D (Ex.: set the CT secondary current for circuit C to 1A)

- ① From the circuit C setting item, press the [↵][⇩] keys to move to "CT secondary current (MENU C3)".
- ② Press the [ENTER] key to enter the setting mode. The setting value in the main display flashes.
- ③ Press the [↵][⇩] keys to select "1A".
- ④ Press the [ENTER] key to confirm your selection.

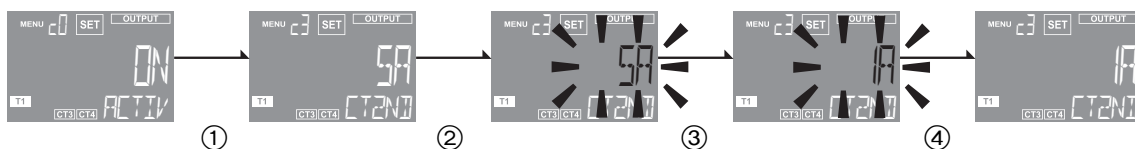

### 4.2 Circuit settings (continued)

#### 3 Set the CT primary current for the circuits enabled from B to D (Ex.: set the CT primary current for circuit C to 50A)

- ① From the circuit C setting item, press the [ $\wedge$ ][ $\vee$ ] keys to move to "CT primary current (MENU C4)".
- ② Press the [ENTER] key to enter the setting mode.
- ③ Press the [ $\wedge$ ][ $\vee$ ] keys to change the value to "50".
  - Press the [←/MODE] key to move one place to the left.
  - If you press the [←/MODE] key on the end at the left, the cursor moves to the right end.
- ④ Press the [ENTER] key to confirm your selection.

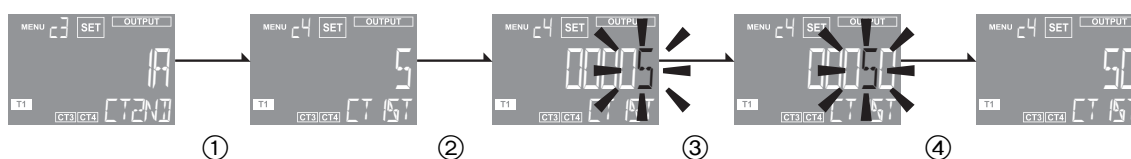

#### 4 Set pulse output ON or OFF (MENU C6) (Ex.: set circuit C to ON)

- ① From the circuit C setting item, press the [ $\wedge$ ][ $\vee$ ] keys to move to "Pulse output ON/OFF (MENU C6)".
- ② Press the [ENTER] key to enter the setting mode.
- ③ Press the [ $\wedge$ ][ $\vee$ ] keys to select "ON".
- ④ Press the [ENTER] key to confirm your selection.

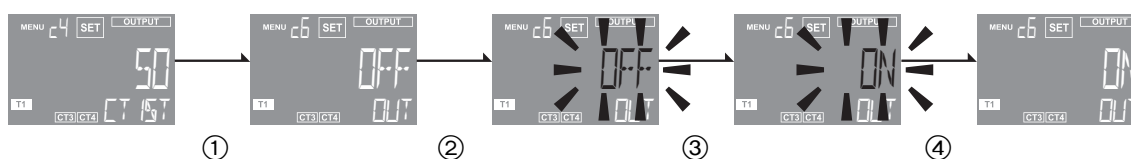

The MENU No. for allocating pulse terminals for circuits B to D are circuit B "B6", circuit C "C6", and circuit D "D6".

#### Caution

- The phase and wire type is set in circuit A. The phase and wire type set for circuit A is shown in the circuit B to D setting items (MENU B1, C1, and D1) and cannot be changed.
- Depending on the phase and wire type set for circuit A, there will be circuits that are unavailable for use. The setting items for circuits unavailable for use will not be displayed.
- You need to set the current for the CT secondary side and CT primary side for each circuit. Confirm the rated values for the CT you are using and set correctly.

## 4.3 RS-485 communication settings

For communications settings other than the communications address, set in the common settings in the settings mode. All circuits will have the same setting.

- You can cancel a change by pressing the [ESC] key before confirming the change.

### ■ Set the protocol (Ex.: set to CompoWay/F)

This unit support the Modbus and CompoWay/F communications protocols. The initial setting is Modbus.

If a measured value is displayed, press and hold the [←/MODE] key and enter your password to switch to the setting mode.

- Press the [←/MODE] key to move to the common settings "CMMN" category display screen. After this, the screen moves automatically to the common settings items and "Protocol (MENU 00)" is displayed.
- Press the [ENTER] key to enter the setting mode.
- Press the [↗][↘] keys to select "COMPF".
- Press the [ENTER] key to confirm your selection.

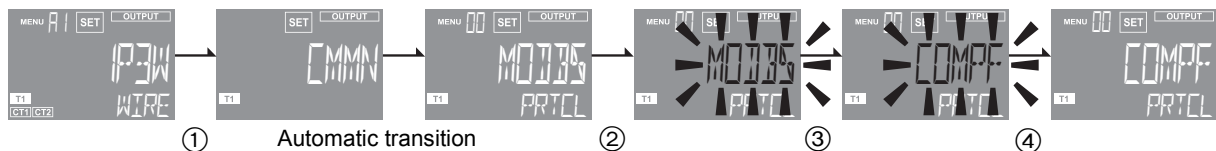

### ■ Set the communication speed (Ex.: set to 38.4 kbps)

- Press the [←/MODE] key to move to the common settings "CMMN" category display screen.
- From the common setting items, press the [↗][↘] keys to move to "Communication speed (MENU 01)".
- Press the [ENTER] key to enter the setting mode.
- Press the [↗][↘] keys to select "38.4K".
- Press the [ENTER] key to confirm your selection.

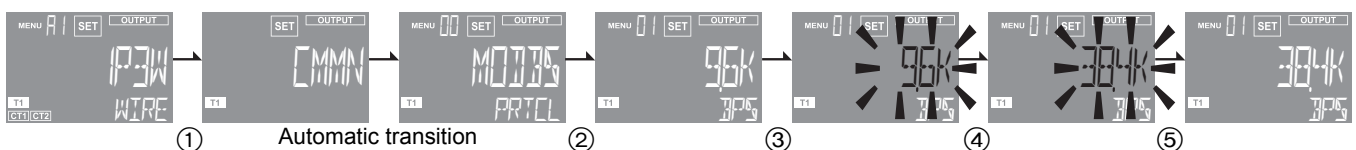

### 4.3 RS-485 communication settings (continued)

#### ■ Set the data bit length (Ex.: set to 7 bits)

Can only be set when the protocol is CompoWay/F.

- ① Press the [←/MODE] key to move to the common settings "CMMN" category display screen.
- ② From the common setting items, press the [↵][⇐] keys to move to "Data length (MENU 02)".
- ③ Press the [ENTER] key to enter the setting mode.
- ④ Press the [↵][⇐] keys to select "7".
- ⑤ Press the [ENTER] key to confirm your selection.



#### Caution

- If the protocol is Modbus, the data bit length is fixed at 8bits.

#### ■ Set the stop bit length (Ex.: set to 2 bits)

Can only be set when the protocol is CompoWay/F.

- ① Press the [←/MODE] key to move to the common settings "CMMN" category display screen.
- ② From the common setting items, press the [↵][⇐] keys to move to "Stop bit length (MENU 03)".
- ③ Press the [ENTER] key to enter the setting mode.
- ④ Press the [↵][⇐] keys to select "2".
- ⑤ Press the [ENTER] key to confirm your selection.

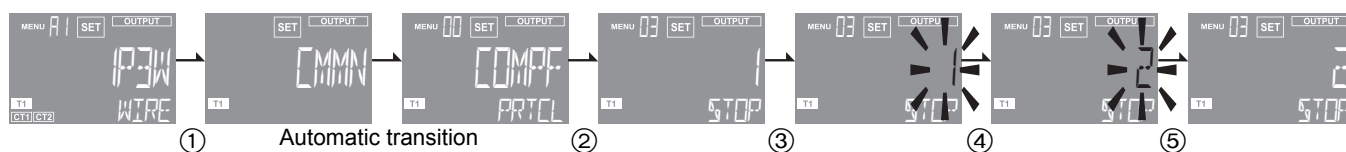

#### Caution

- If the protocol is Modbus, then the stop bit length is automatically set according to the vertical parity setting (⇒ 61) as follows:
  - "2" if the vertical parity is "NONE"
  - "1" if the vertical parity is "ODD" or "EVEN"

## 4.3 RS-485 communication settings (continued)

### ■ Set the vertical parity (Ex.: set to ODD)

Select "NONE" for no parity, "EVEN" for even parity, and "ODD" for odd parity.

- ① Press the [←/MODE] key to move to the common settings "CMMN" category display screen.
- ② From the common setting items, press the [↵][↵] keys to move to "Parity (MENU 04)".
- ③ Press the [ENTER] key to enter the setting mode.
- ④ Press the [↵][↵] keys to select "ODD".
- ⑤ Press the [ENTER] key to confirm your selection.



### ■ Set the transmission wait time (Ex.: set to 15 msec)

You can set the time to wait between when a response is created and when it is sent. The setting can be changed in units of 1ms. The default value is 20ms.

- ① Press the [←/MODE] key to move to the common settings "CMMN" category display screen.
- ② From the common setting items, press the [↵][↵] keys to move to "Transmission wait time (MENU 05)".
- ③ Press the [ENTER] key to enter the setting mode.
- ④ Press the [↵][↵] keys to change the value to "15".
  - Press the [←/MODE] key to move one place to the left.
  - If you press the [←/MODE] key on the end at the left, the cursor moves to the right end.
- ⑤ Press the [ENTER] key to confirm your change.

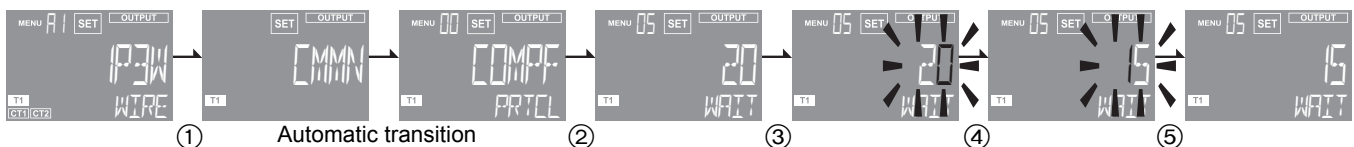

# 4.4 Pulse output settings

This product has 4 pulse output ports (OUT1, OUT2, OUT3, OUT4). You can set output ON or OFF for each output port in the pulse output settings.

When the active energy exceeds the output units, a pulse wave is output from the ports for which pulse output is set to ON.

The following diagram shows pulse output waveforms. The ON output width is fixed at 500ms. The OFF sustained width after output is 100ms.

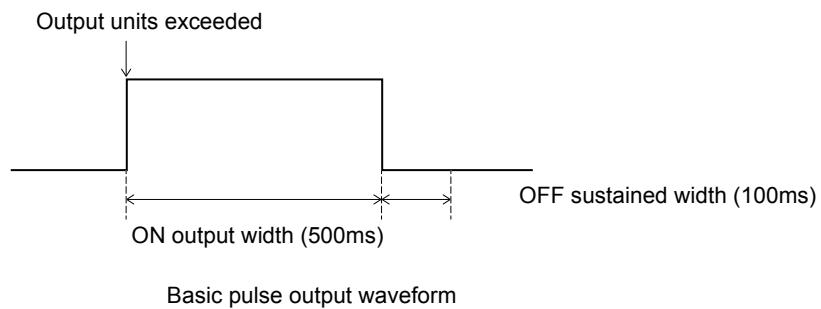

An alarm is displayed when there is a pulse output error (⇒ 102). A pulse output error may be either of the following states.

- The output unit is exceeded again while still in the ON output state.  
Action when error occurs: The pulse output continues for more than 500ms due to the unit being exceeded again.
- Output unit is exceeded within the OFF sustained width.  
Action when error occurs: Pulse is output within the time of the OFF sustained width.

### ■ Set the pulse output units (Ex.: set to 10kWh/pulse)

Pulse output units settings are common to all ports. The default value is 100Wh/pulse. You can cancel a change by pressing the [ESC] key before confirming the change.

- ① Press the [←/MODE] key to move to the common settings "CMMN" category display screen.
- ② From the common setting items, press the [↵][⇐] keys to move to "Pulse output units (MENU 09)".
- ③ Press the [ENTER] key to enter the setting mode.
- ④ Press the [↵][⇐] keys to select "10k".
- ⑤ Press the [ENTER] key to confirm your selection.

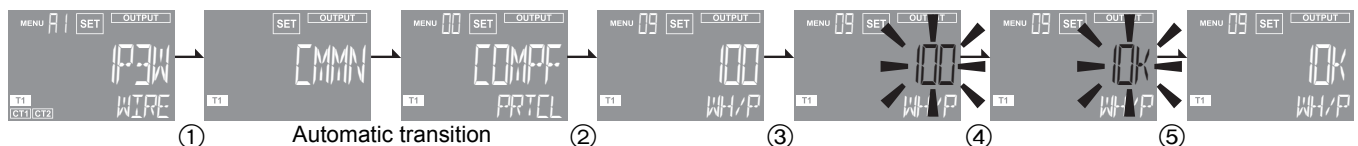

## 5.1 Voltage assignment

If the phase and wire type has been set to 1-phase 2-wire voltage selected (1P2W2) or 1-phase 3-wire composite (1P3W2), then you need to set the voltage for the 1-phase 2-wire circuit doing the measuring. Set either R-N phase or T-N phase if the input voltage is AC100V, and set R-T phase of the input voltage is AC200V.

As the following diagram shows, the 1-phase 2-wire circuit for which the voltage allocation is set is circuit A, circuit B, circuit C, and circuit D for 1P2W2 wiring and circuit C and circuit D in the 1P3W2 wiring diagram.

You need to allocate voltage for each circuit.

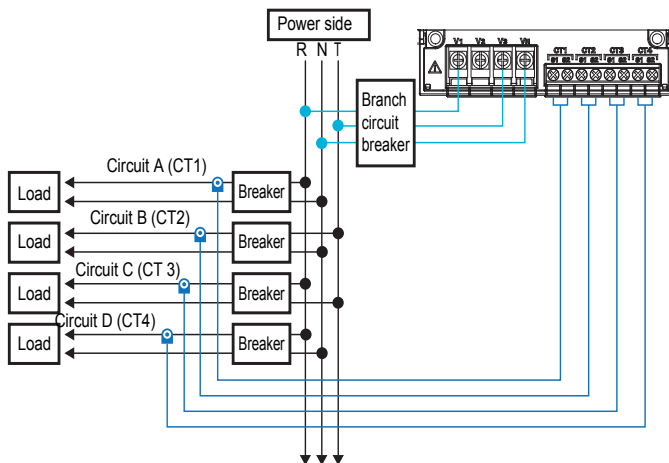

Wiring diagram for 1-phase 2-wire voltage selected

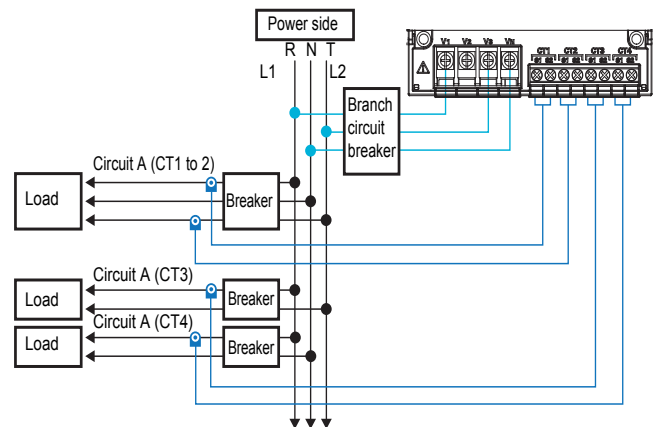

Wiring diagram for 1-phase 3-wire composite

### ■ Set the voltage assignment (Ex.: set the voltage assignment for circuit C to V\_R-T)

If a measured value is displayed, press and hold the [ $\ll$ /MODE] key and enter your password to switch to the setting mode.

- ① Press the [ $\ll$ /MODE] key to move to the settings category display screen for circuit C.
- ② From the circuit C setting item, press the [ $\wedge$ ][ $\vee$ ] keys to move to "Voltage assignment (MENU C5)".
- ③ Press the [ENTER] key to enter the setting mode.
- ④ Press the [ $\wedge$ ][ $\vee$ ] keys to select "V\_R-T".
- ⑤ Press the [ENTER] key to confirm your selection.

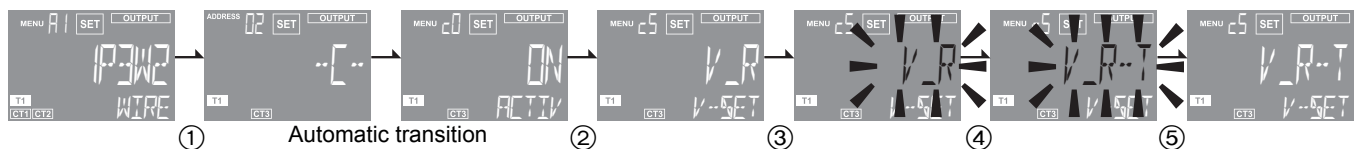

#### Information

- The MENU No. for allocating voltage for circuit A is "A5".
- The MENU No. for allocating voltage for circuits B to D are circuit B "B5", circuit C "C5", and circuit D "D5".

## 5.2 Measuring high voltage

When measuring 6600V within a cubicle, for example, and the measured voltage exceeds 480V, you need to use a transformer to convert the voltage to fit within the input voltage range of this unit. Set the multiplication factor from the primary voltage value and the secondary voltage value. For example, if the primary voltage is 880V and the secondary voltage is 110V, this becomes  $880/110=8.00$ .

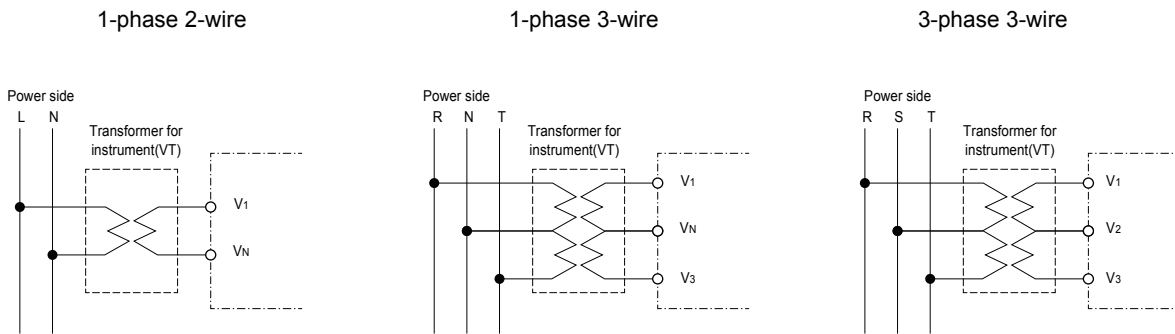

### ■ Set the VT ratio (Ex.: set to 8.00)

If a measured value is displayed, press and hold the [ $\ll$ /MODE] key and enter your password to switch to the setting mode.

- ① Press the [ $\ll$ /MODE] key to move to the common settings "CMMN" category display screen.
- ② From the common setting items, press the [ $\wedge$ ][ $\vee$ ] keys to move to "VT ratio (MENU 06)".
- ③ Press the [ENTER] key to enter the setting mode. The second decimal place of the setting value in the main display flashes.
- ④ Press the [ $\wedge$ ][ $\vee$ ] keys to change the value to "8.00".
  - Press the [ $\ll$ /MODE] key to move one place to the left.
  - If you press the [ $\ll$ /MODE] key on the end at the left, the cursor moves to the right end.
- ⑤ Press the [ENTER] key to confirm your change.

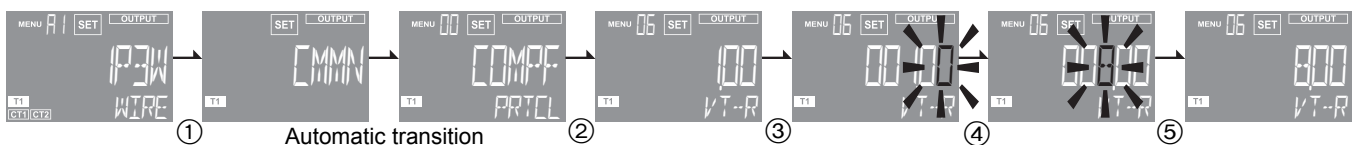

### Caution

- When measuring voltage under 480V, accuracy can be improved by directly entering the voltage rather than by using a transformer.

## 5.3 Display unit conversion

You can multiply the active energy for each circuit by a specified factor and display the result along with a unit. You can convert the active energy to a monetary figure or volume of CO<sub>2</sub>. You can include any 3 letters of the alphabet or numbers for the units displayed.

### ■ Set the conversion rate (Ex.: set to 0.300)

If a measured value is displayed, press and hold the [←/MODE] key and enter your password to switch to the setting mode.

- ① Press the [←/MODE] key to move to the common settings "CMMN" category display screen.
- ② From the common setting items, press the [↵][↵] keys to move to "Conversion rate (MENU 07)".
- ③ Press the [ENTER] key to enter the setting mode. The third decimal place of the setting value in the main display flashes. The decimal point cannot be changed.
- ④ Press the [↵][↵] keys to change the value to "0.300".
  - Press the [←/MODE] key to move one place to the left.
  - If you press the [←/MODE] key on the end at the left, the cursor moves to the right end.
- ⑤ Press the [ENTER] key to confirm your change.

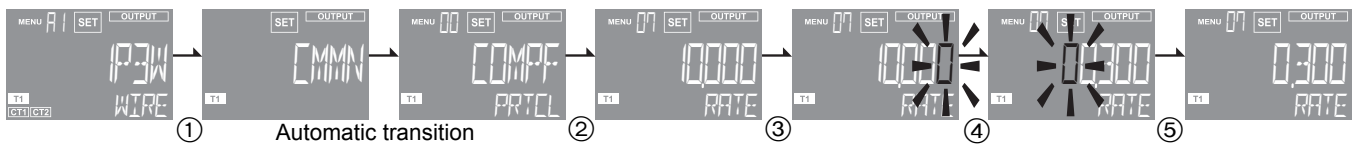

### 5.3 Display unit conversion (continued)

#### ■ Set the conversion display units (Ex.: set to \_KG)

If a measured value is displayed, press and hold the [←/MODE] key and enter your password to switch to the setting mode.

- ① Press the [←/MODE] key to move to the common settings "CMMN" category display screen.
- ② From the common setting items, press the [↵][⇐] keys to move to "Conversion display units (MENU 08)".
- ③ Press the [ENTER] key to enter the setting mode. The rightmost value of the setting value in the main display flashes.
- ④ Press the [↵][⇐] keys to change the value to "\_KG".
  - Press the [←/MODE] key to move one place to the left.
  - If you press the [←/MODE] key on the end at the left, the cursor moves to the right end.
- ⑤ Press the [ENTER] key to confirm your change.

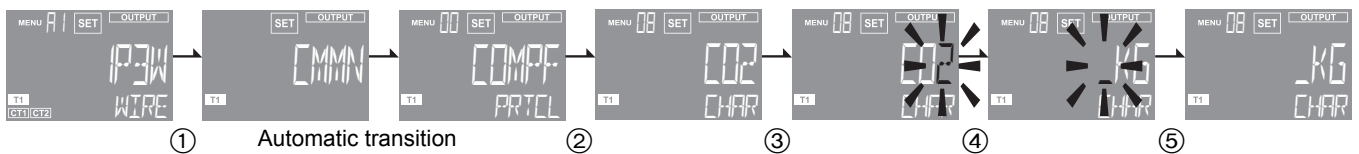

#### Caution

- Use 3 characters, being alphanumeric characters or symbols, for the conversion display units.

#### Information

- If a space is required for the displayed units, you can use the underscore ( \_ ) instead.
- You can enter the following characters in each of the places in the conversion display unit setting.  
Numbers: 0 to 9, alphabet: A to Z, symbols: - (hyphen), \_ (underscore), and / (slash)
- If lower case letters are set from the host device by communication, they are automatically changed to upper case.
- Refer to "8.2 ASCII code table (⇒ 109)" for the ASCII codes for each of the characters.

## 5.4 Power saving mode

This feature turns the LCD display off after the set time elapses. When the LCD is off, it can be turned on again by operating any key.

### ■ Set the automatic LCD off time (Ex.: set to 10 minutes)

If a measured value is displayed, press and hold the [←/MODE] key and enter your password to switch to the setting mode.

- ① Press the [←/MODE] key to move to the common settings "CMMN" category display screen.
- ② From the common setting items, press the [↵][↵] keys to move to "Automatic LCD off(MENU A0)".
- ③ Press the [ENTER] key to enter the setting mode.
- ④ Press the [↵][↵] keys to select "10.0".
- ⑤ Press the [ENTER] key to confirm your selection.

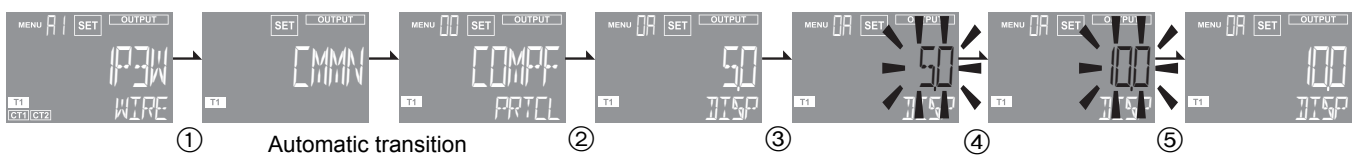

## 5.5 Warning for voltage miss-wiring

This feature shows alarms when voltage phase for the phase and wire type is open, when the wrong phase sequence (for 1-phase 3-wire, 3-phase 3-wire, and 3-phase 4-wire) is detected, when the active power is a negative value, or when the frequency goes out of the rated range (⇒ 102).

- If the V1 voltage phase is under 85V, this is "VR open phase warning".
- If the V2 voltage phase is under 85V, this is "VS open phase warning"
- If the V3 voltage phase is under 85V, this is ""VT open phase warning"
- A phase sequence error occurs when the phase sequence for 3-phase 4-wire, 1-phase 3-wire, and 3-phase 3-wire is incorrect.
- If the phase of the voltage and current differ and the active power is a negative value, the error is "Active power is a negative value".
- If the frequency goes out of the range between 45 and 65Hz, the error is "Input frequency error warning".

### Information

- If the alarm LED flashes, it cancels after you make corrections to the wiring and input and then restart the unit.

### ■ Set the warning for voltage miss-wiring (Ex.; set to OFF)

If a measured value is displayed, press and hold the [←/MODE] key and enter your password to switch to the setting mode.

- ① Press the [←/MODE] key to move to the common settings "CMMN" category display screen.
- ② From the common setting items, press the [↗][↘] keys to move to "Warning ON/OFF (MENU 0B)".
- ③ Press the [ENTER] key to enter the setting mode.
- ④ Press the [↗][↘] keys to select "OFF".
- ⑤ Press the [ENTER] key to confirm your selection.



## 5.6 Tariff feature

This feature allows you to select a location to save cumulative active energy data from T1 to T4.

Using the tariff feature allows you to, for example, change the location to save active energy so that you can later on check the sum of active energy during a particular time period (for example, night and day when the electricity charges are different).

- The current tariff default value is T1.
- The value for the current tariff can only be changed from the communication settings (⇒ 74).

### ■ Set the tariff function (Ex.: set to OFF)

If a measured value is displayed, press and hold the [←/MODE] key and enter your password to switch to the setting mode.

- ① Press the [←/MODE] key to move to the common settings "CMMN" category display screen.
- ② From the common setting items, press the [↵][⇩] keys to move to "Tariff ON/OFF (MENU 0C)".
- ③ Press the [ENTER] key to enter the setting mode.
- ④ Press the [↵][⇩] keys to select "OFF".
- ⑤ Press the [ENTER] key to confirm your selection.

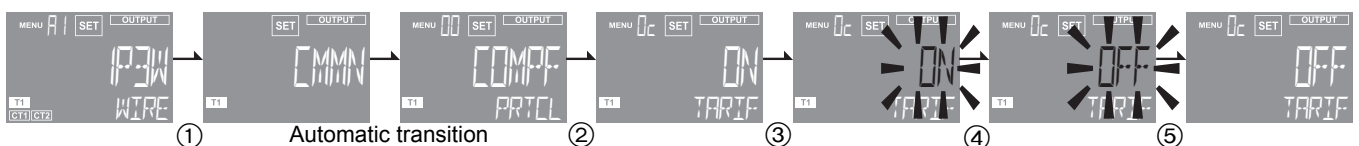

# 5.7 Change password

- This enables you to change the password that you need to enter when moving from the measuring mode to the setting mode.
- You can set a password of 4 numerals between 0000 and 9999.
- The default password is "0001".
- There is no functionality to disable the password setting.

## ■ Set the password (Ex.: set to 3060)

If a measured value is displayed, press and hold the [←/MODE] key and enter your password to switch to the setting mode.

- ① Press the [←/MODE] key to move to the common settings "CMMN" category display screen.
- ② From the common setting items, press the [↵][↵] keys to move to "Change password (MENU 0D)".
- ③ Press the [ENTER] key to enter the setting mode.
- ④ Press the [↵][↵] keys to change to "3060".
  - Press the [←/MODE] key to move one place to the left.
  - If you press the [←/MODE] key on the end at the left, the cursor moves to the right end.
- ⑤ "ONCE AGAIN" is displayed when you press the [ENTER] key.
- ⑥ The screen to enter the password the second time is displayed.
- ⑦ Input the password you entered in ④ (3060) again.
- ⑧ "OK" is displayed when you press the [ENTER] key, the display transitions to the "Change password (MENU 0D)" display, and the password has been changed successfully.

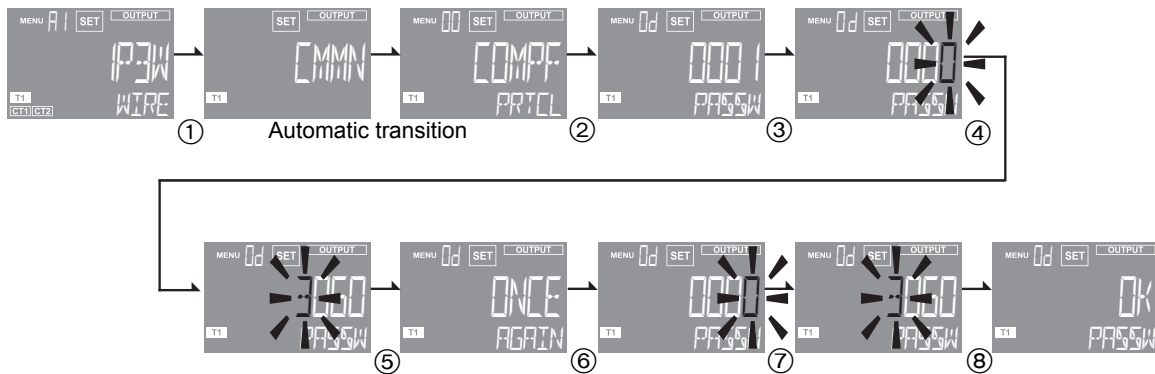

NG is displayed if the password you entered the first time and the second time are different, and the display returns to "Change password (MENU 0D)".

Change the password again.



### Important

- You will be unable to reset the password if you forget it. Take care to note the password carefully when changing it.
- If you forget the password, contact the place of purchase or the manufacturer.

## 5.8 Checking software version

You can check the version of software this product is using.

### ■ Checking software version

If a measured value is displayed, press and hold the [←/MODE] key and enter your password to switch to the setting mode.

- ① Press the [←/MODE] key to move to the other settings "ETC" category display screen.  
Next, the display automatically transitions to the "Check software version (MENU 90)" screen, displaying the software version on the upper line and the product model on the lower line.

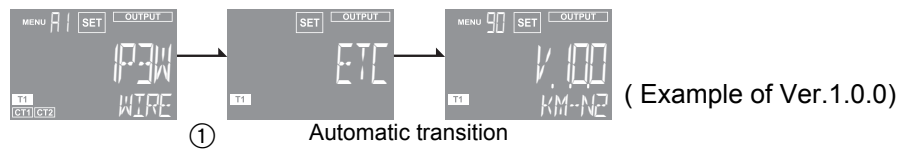

# 5.9 Initialize

There are three different types of initialization.

- (1) Resetting the active energy for each circuit
- (2) Resetting the active energy for all circuits
- (3) Resetting the active energy and setting values for all circuits

- Setting values remain unchanged if you do either (1) or (2).
- The settings for each of the circuits are also reset if you do (3). The unit restarts after you do this.

## ■ Resetting the active energy for each circuit (example: resetting circuit A)

If a measured value is displayed, press and hold the [←/MODE] key and enter your password to switch to the setting mode.

- ① From the circuit A setting items, press the [↗][↘] keys to move to "Active energy reset (MENU A7)".
- ② When you press and hold the [ENTER] key, the dashes (-) reduce from the left side of the main screen.
- ③ Keep pressing the [ENTER] key.
- ④ When the dashes (-) disappear, and "DONE" flashes on the screen, the active energy for Circuit A has been reset.

After completing initialization, "MENU 07" is displayed again.



### Information

- The MENU No. for resetting active energy values for circuits B to D are circuit B "B7", circuit C "C7", and circuit D "D7".

## 5.9 Initialize (continued)

### ■ Resetting the active energy for all circuits

If a measured value is displayed, press and hold the [←/MODE] key and enter your password to switch to the setting mode.

- ① Press the [←/MODE] key to move to the other settings "ETC" category display screen.
- ② From the other setting items, press the [↑][↓] keys to move to "All active energy reset (MENU 91)".
- ③ When you press and hold the [ENTER] key, the dashes (-) reduce from the left side of the main screen.
- ④ Keep pressing the [ENTER] key.
- ⑤ When the dash (-) disappears, and "DONE" flashes on the screen, the active energy for all circuits has been reset.

After completing initialization, "MENU 91" is displayed again.

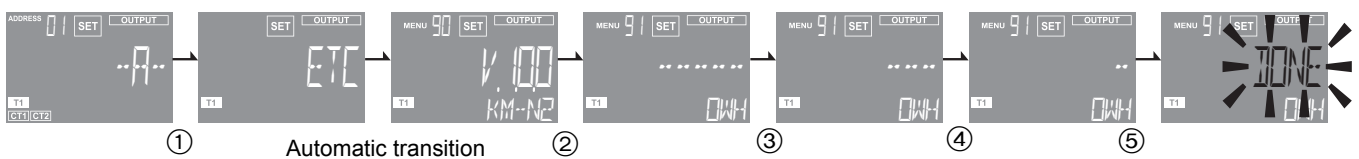

### ■ Resetting the active energy and setting values for all circuits

If a measured value is displayed, press and hold the [←/MODE] key and enter your password to switch to the setting mode.

- ① Press the [←/MODE] key to move to the other settings "ETC" category display screen.
- ② From the other setting items, press the [↑][↓] keys to move to "Initialize (MENU 92)".
- ③ When you press and hold the [ENTER] key, the dashes (-) reduce from the left side of the main screen.
- ④ Keep pressing the [ENTER] key.
- ⑤ When the dash (-) disappears, and "DONE" flashes on the screen, the active energy and setting values for all circuits has been reset.

After initializing, press and hold the [←/MODE] key to move to the measuring mode and restart the unit.

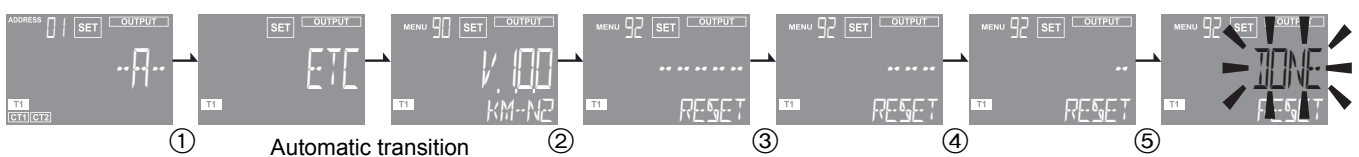

#### Information

- You can cancel the reset by pressing [ESC] before "DONE" is displayed.

## 6.1 Overview of communications

Using the communications features enables you to create programs on host devices (such as computers) to collect the data measured by this product and to change its settings.

Each circuit on this product is allocated different communications addresses (numbered in order). (⇒ 23)

Even if you connect several of these products on the same RS-485 line, all of the circuits need to be allocated different communications addresses.(⇒ 59)

Circuits are identified by their communications addresses. These are indicated in the address maps in "6.4 Address map(⇒ 98)" and the addresses for each circuit are all the same.

You can use the Modbus and CompoWay/F protocols for communication.

### ■ Communications specifications

Communications protocols	Modbus	CompoWay/F
Transmission connections	Multi-drop (1:N connection)	
Communication system	2 line half duplex	
Sync method	Asynchronous	
Baud rate	2.4, 4.8, <u>9.6</u> , 19.2, 38.4kbps	
Transfer code	Binary	ASCII
Data bit length	<u>8 bits (fixed)</u>	7 or 8 bits
Stop bit length	With parity: <u>1 bit</u> Without parity: 2 bits	1 or 2 bits
Error detection	Vertical parity (none, <u>odd</u> , even) Check code: CRC-16	Vertical parity (none, odd, even) Check code: BCC
Flow control	None	
Interface	RS-485	
Retry function	None	
Communication response Transmission wait time	0 to 99 (ms), <u>Default 20 (ms)</u>	
Transmission buffer	230 (byte)	

\* Default values are underlined.

### ■ Transmission procedure

The host device (a computer, for example) sends the command frame and model KM-N2 sends the response frame that corresponds to the command content. So 1 response frame is sent in response to one command frame. The command frame and response frame act as follows.

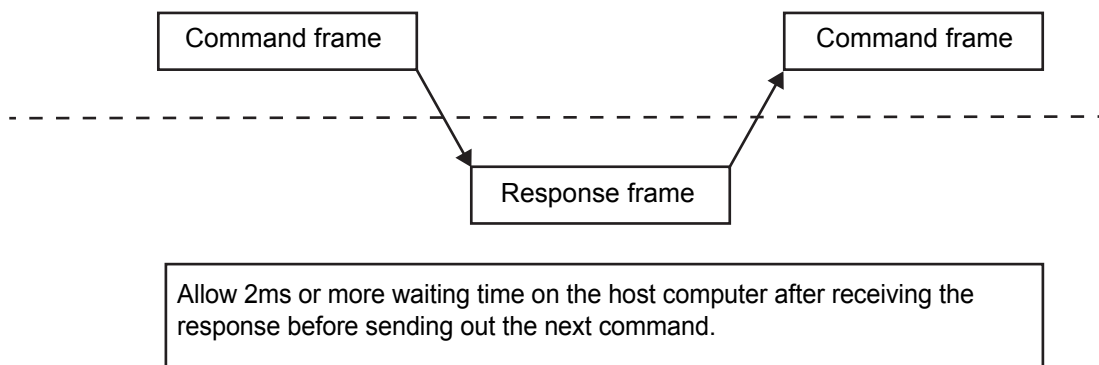

## 6.2 Modbus

### ● Data format

In the following explanations, values preceded by H' (as in H'02) indicate hexadecimal values. The numbers under the frame sections are the number of bytes. Also, the transfer code is binary for Modbus.

#### ■ Command frame

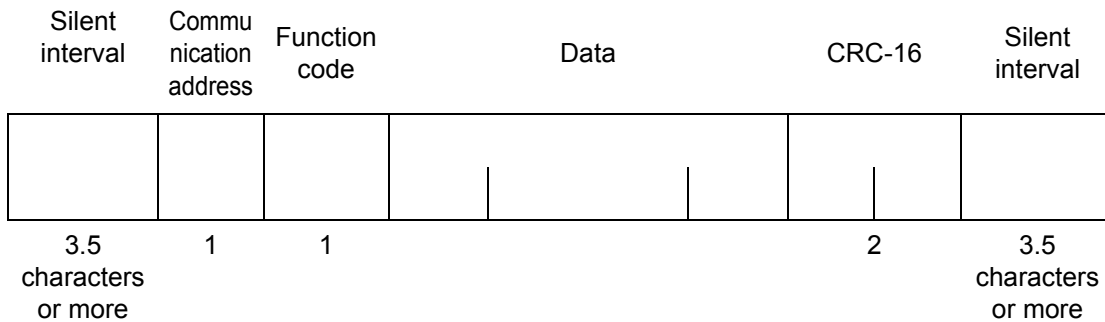

Silent interval	A non-communication time of 3.5 characters worth of time or more
Communication address	<ul style="list-style-type: none"> <li>Specifies the "Communication address" of this product.</li> <li>Figures in hexadecimal format between H'01 to H'63 (01 to 99) can be set.</li> <li>Specify H'00 to communicate to all at the same time. There will be no response if this is specified however.</li> </ul>
Function code	Code to indicate the type of command.
Data	Data text to match the function code.
CRC-16	Cyclical Redundancy Check This check code is for the communication address until the end of the data.

#### ■ Response frame when normal

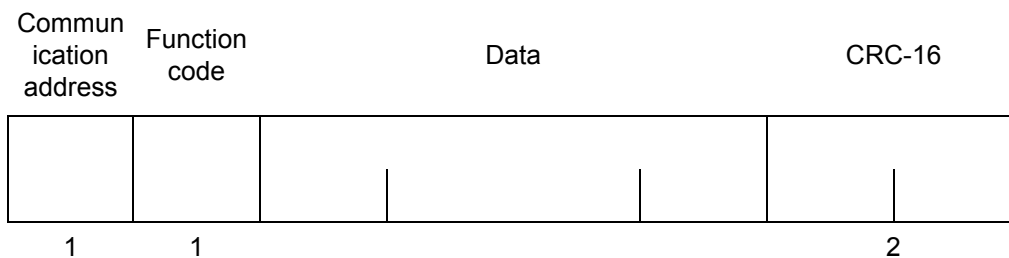

Communication address	The number specified by the command from is inserted as is. The communication address that returned the response.
Function code	Function code that was received.
Data	Data received.
CRC-16	Cyclical Redundancy Check This check code is for the communication address until the end of the data.

## 6.2 Modbus (continued)

### ■ Response frame when there is an error

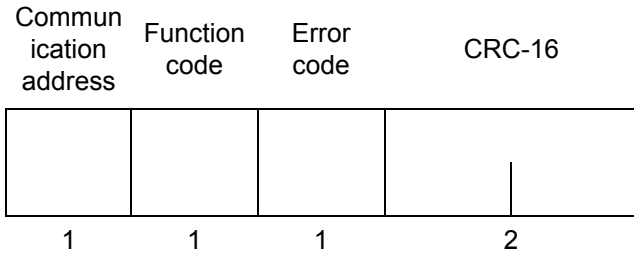

Communication address	The number specified by the command from is inserted as is. This is the communication address that returned the response.
Function code	In the response frame when an error occurs, the addition of "H'80" to the received function code indicates that it is an error response. For example: If the response is H'03 normally, then a response when there is an error would be H'83.
Error code	An exit code to describe an error.
CRC-16	Cyclical Redundancy Check This check code is for the communication address until the end of the data.

### ■ An example for CRC-16 calculation

The work for calculation (16 bit register: CRC register hereunder) is processed byte by byte in the message.

- ① Make the initial value of the CRC register H'FFFF
- ② Use an XOR on the lower 8 bits of the CRC register and the first byte of data, return that result to the CRC register, then while embedding the "0", move the CRC register 1 bit to the right
- ③ If the bit shifted from the LSB is "0", repeat step ② (the following bit shift process). If the bit shifted from the LSB is a "1", use an XOR calculation on the CRC register and H'A001, returning that result to the CRC register
- ④ Repeat steps ③ and ④ until 8 bits worth of data has been shifted
- ⑤ If the end of the message is not reached, use an XOR on the CRC register and the next byte of data, return that result to the CRC register and repeat step ③
- ⑥ The calculated result (the value of the CRC register) is appended to the message starting from the lower byte

### Example of appending the calculated result

If the calculated CRC value is H'1234, it is appended to the command frame as below.

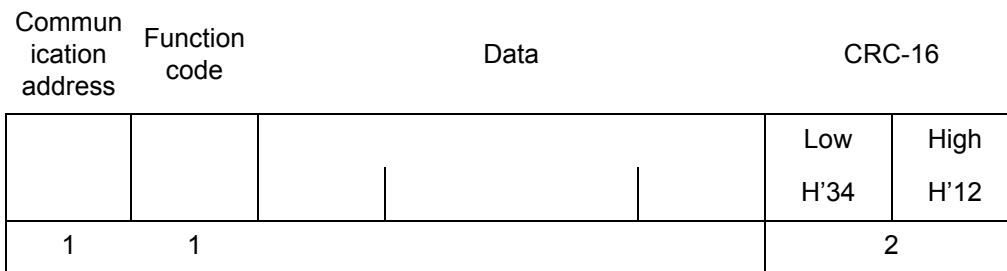

Range of CRC-16 calculation

## 6.2 Modbus (continued)

### ● List of function codes (FC)

Function code	Name	Description
03(H'03)	Variable area reading	Variable area is read successively.
16(H'10)	Variable area writing	Variable area is written successively.
06(H'06)	Command	Operations are performed according to commands.
08(H'08)	Echo back test	Echo back test is performed.

### ● List of error codes

Error code	Name	Description	Error detection Priority
H'01	Function code error	Using an unsupported function code.	1
H'02	Variable address error	Invalid value specified for variable address.	2
H'03	Variable data error	Data is invalid. <ul style="list-style-type: none"> <li>• Mismatch with the number of elements</li> <li>• Data outside of range</li> </ul>	3
H'04	Operation error	The mode is not appropriate.	4
H'05	Status error (error is occurring)	A malfunction has occurred and the unit continues to be unusable.	5

## 6.2 Modbus (continued)

### ● Service details

#### ■ Variable area read (03: H'03)

This service allows you to read all variable areas.

Reading of the variable areas is conducted by setting the required data in the following command frame. To read setting values "Parameter area list (⇒ 100)", you need to first move to the setting mode with a command. To read measurement values "List of variable areas (measurement values) (⇒ 98)", you can be in either the measuring mode or the setting mode. Also, measuring continues even while in the setting mode.

#### Command frame

Commu- nication address	Function code	Start reading address	Number of elements	CRC-16
1	H'03	2	2	2

- **Start reading address**  
Specify the address for the measurement value or setting data you want to read. Refer to "6.4 Address map (⇒ 98)" for the address.
- **Number of elements**  
Specify the number of pieces of data that you want to read times 2 as the number of elements. Only the consecutive addresses can be read in a batch.  
Range: H'0002 to 0032 (2 to 50).
- **CRC-16**  
This is a check code calculated from the communication address until the end of the data. Refer to "An example for CRC-16 calculation" for the calculation. (⇒ 76)

## 6.2 Modbus (continued)

### Response frame

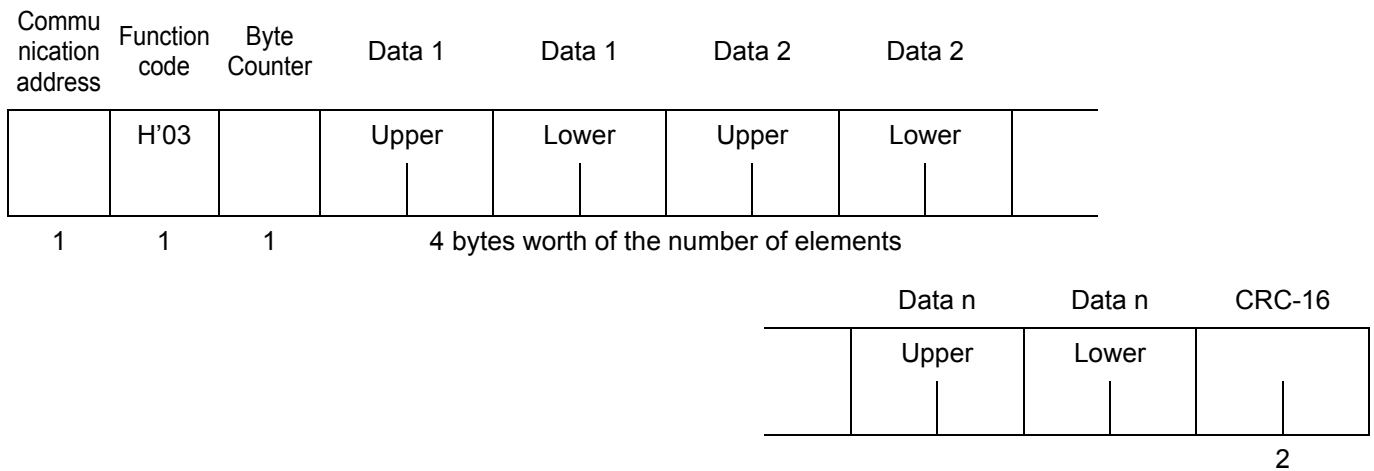

- **Byte counter**  
The number of bytes of the read data is put here.
- **Data 1 to n**  
The value of the read data is put here.
- **CRC-16**  
This is a check code calculated from the communication address until the end of the data.  
Refer to "An example for CRC-16 calculation" for the calculation. (⇒ 76)

### Command/Response example

The following is an example of reading voltage 1.  
(Communication address: When H'01)

#### Command

Communication address	Function code	Start reading address	Number of elements	CRC-16
01	03	0000	0002	C40B

#### Response

Communication address	Function code	Byte Counter	Data 1	Data 1	CRC-16
01	03	04	0000	0960	FC4B

## 6.2 Modbus (continued)

### ■ Variable area writing (16: H'10)

Writing to the variable areas is conducted by setting the required data in the following command frame. The parameter area can be written to. Before writing, you need to first move to the setting mode with a command. The content written is reflected by moving to the measuring mode in response to an instruction after writing of the parameters. Measuring continues even while in the setting mode.

#### Command frame

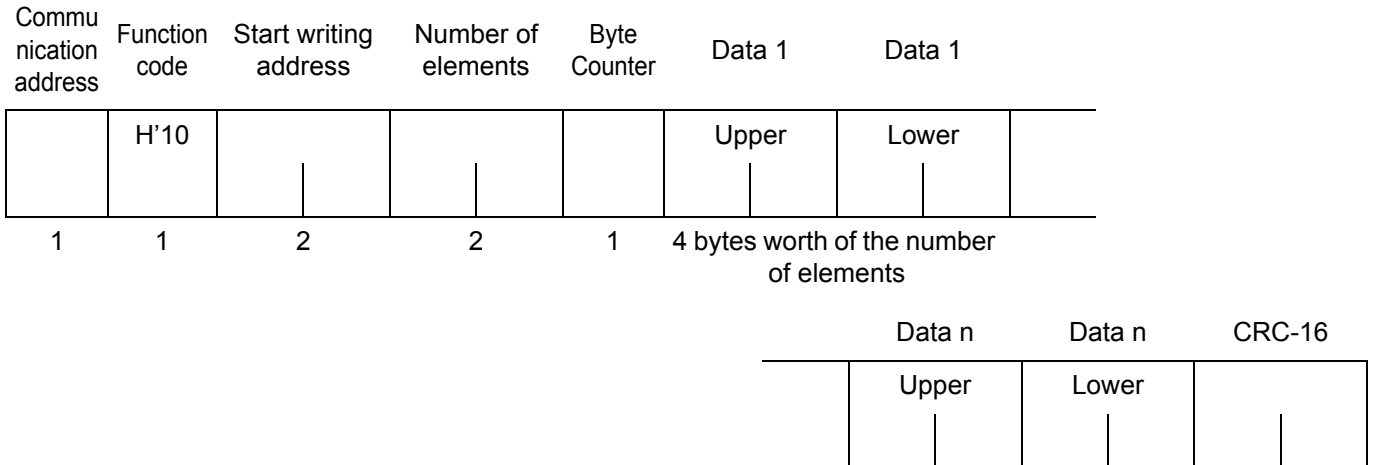

- Start writing address**  
 Specify the address for setting data you want to write. Refer to "6.4 Address map (⇒ 98)" for the address.
- Number of elements**  
 Specify the number of pieces of data that you want to write times 2 as the number of elements.  
 Range: H'0002 to 0032 (2 to 50).
- Byte counter**  
 Specify the number of bytes for written data.
- CRC-16**  
 This is a check code calculated from the communication address until the data immediately preceding.  
 Refer to "An example for CRC-16 calculation" for the calculation. (⇒ 76)

## 6.2 Modbus (continued)

### Response frame

Communication address	Function code	Start writing address	Number of elements	CRC-16
1	H'10	2	2	2

- **Start writing address**

The start writing address that was received.

- **Number of elements**

The number of elements that were received.

- **CRC-16**

This is a check code calculated from the communication address until the data immediately preceding. Refer to "An example for CRC-16 calculation" for the calculation. (⇒ 76)

### Command/Response example

The following shows an example of writing when changing the phase and wire type to 1-phase 2-wire.

(Communication address: When H'01)

Address: H'2000 Written data: H'00000000

#### Command

Communication address	Function code	Start writing address	Number of elements	Byte Counter	Data 1	Data 1	CRC-16
01	10	2000	0002	04	0000	0000	6A6E

#### Response

Communication address	Function code	Byte Counter	Number of elements	CRC-16
01	10	04	0002	DD00

## 6.2 Modbus (continued)

### ■ Command (06: H'06)

#### Command frame

Communication address	Function code	Start writing address	Written data	CRC-16
1	H'06	H'FF Fixed	H'FF Fixed	2
1		2	2	2

#### Response frame

Communication address	Function code	Start writing address	Written data	CRC-16
1	H'06	H'FF Fixed	H'FF Fixed	2
1		2	2	2

- **Start writing address**

Set "FFFF" as the dedicated address for commands.

- **Written data**

The written data is 4 places consisting of the command code plus the related information. Commands are as follows. Specify command codes using hexadecimal numbers.

Instruction code	Related information	Instruction details
03(H'03)	00	Resets any active energy values that can be reset (individual units)
04(H'04)	00	Move to measuring mode
07(H'07)	00	Moving to setting mode
09(H'09)	00	Initialize (any active energy values that can be reset and setting values)

## 6.2 Modbus (continued)

### Command/Response example

The following is an example of an instruction for clearing the active energy.

(Communication address: When H'01)

Command code: "03" Related information: "00"

#### Command

Communication address	Function code	Start writing address	Written data	CRC-16
01	06	FFFF	0300	891E

#### Response

Communication address	Function code	Start writing address	Written data	CRC-16
01	06	FFFF	0300	891E

### ■ Echo back test (08: H'08)

#### Command frame

Communication address	Function code	Start writing address	Test data	CRC-16
	H'08	H'00 Fixed   Fixed		
1	1	2	2	2

#### Response frame

Communication address	Function code	Start writing address	Test data	CRC-16
	H'08	H'00 Fixed   Fixed		
1	1	2	2	2

- **Start writing address**

Set "0000" as the address for the echo back test.

- **Test data**

This is any data in 2-byte HEX format.

# 6.3 CompoWay/F

## ● Data format

In the following explanations, values preceded by H' (as in H'02) indicate hexadecimal values. Only items expressed as normal numerals or characters indicate ASCII characters.

The numbers under the frame sections are the number of bytes.

### ■ Command frame

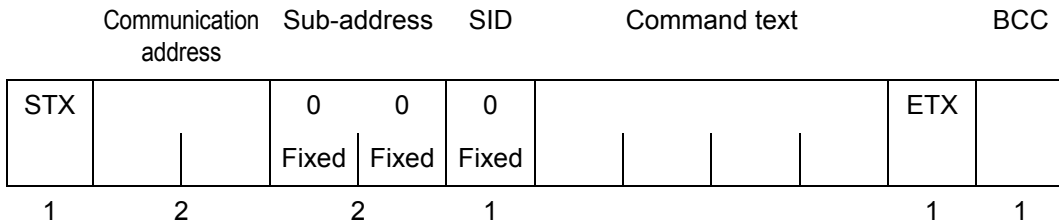

STX	This is the start code for the communication frame (H'02). • Make sure you set this code as the first byte.
Communication address	Specify the "communications address" of this product. • You can set a number between 00 and 99 or XX (upper case). • Specify "XX" to communicate to all at the same time. There will be no response if this is specified however. • Specify the communications address between 00 and 99 (BCD). There will be no response to any other communications address.
Sub-address	Not used for this product. Specify "00".
SID	Not used for this product. Specify "0".
Command text	This part describes the command.
ETX	Code to indicate the end of text. • Make sure you set the H'03 code as the end byte.
BCC	The block check character. • The BCC shall be the value gained from an exclusive OR (XOR) function conducted on each byte from the communications address to ETX.

### ■ Example of BCC calculation

The block check character (BCC) is calculated using an exclusive OR function on each byte of the values between the communications address and ETX, then that 8-bit data is set in the BCC section.

	Communication address	Sub-address	SID	Command text	ETX	BCC
02H	0(30H)   0(30H)	0(30H)   0(30H)	0(30H)	0(30H)   5(35H)   0(30H)   3(33H)	03H	35H
	BCC calculation range					

$$BCC = 30H \oplus 30H \oplus 30H \oplus 30H \oplus 30H \oplus 30H \oplus 35H \oplus 30H \oplus 33H \oplus 03H = 35H$$

The calculation result 35H is set in the BCC section.

## 6.3 CompoWay/F (continued)

### ■ Response frame

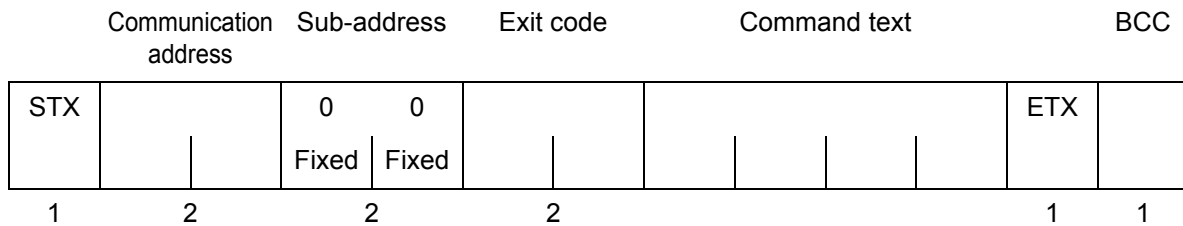

Exit code	Name	Description	Error detection Priority
00	Normal end	This indicates that the command ended normally and that there was no error.	None
0F	FINS command error	The specified FINS command could not be executed. Determine the reason for non-execution from the FINS response code.	3
14	Format error	<ul style="list-style-type: none"> <li>The numbers 0 to 9 and letters A to F are used in command text (except in echo back tests).</li> <li>There is no SID or command text. Alternatively, there is no command text. MRC/SRC in the command text is incomplete.</li> </ul>	2
16	Sub-address error	<ul style="list-style-type: none"> <li>The sub-address is invalid.</li> </ul>	1

- The exit code is returned as the reply when 1 command frame is received when sent to this unit.
- There is no response if the command is not complete between ETX and BCC.
- The error detection priority is the order when more than one error occurs.

### ■ Example exit codes

The following is an example of exit codes when the command did not end normally.  
For example: When there is no command text

#### Command

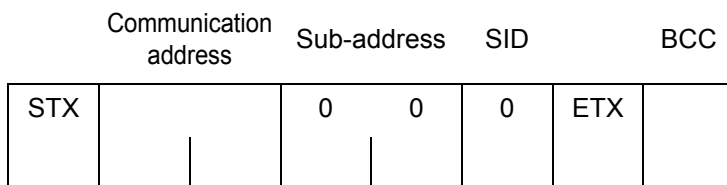

#### Response

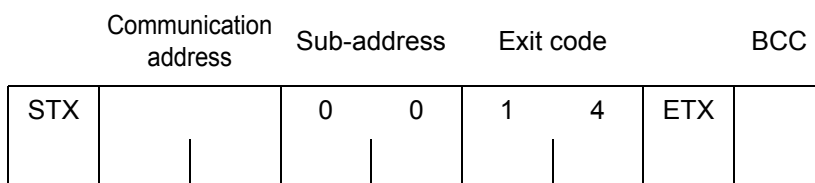

The exit code will be "14" (format error).

### 6.3 CompoWay/F (continued)

For example: The sub-address is less than 2 characters and there is no SID or FINS-mini

**Command**

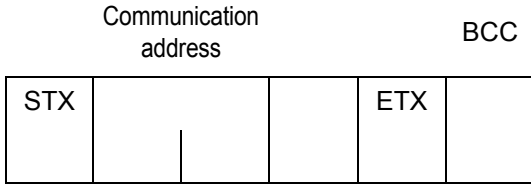

The sub-address lacks a character

**Response**

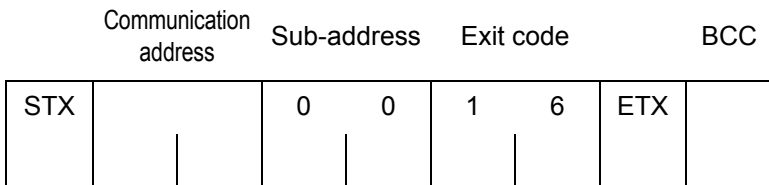

The sub-address is "00" and the exit code is "16" (a sub-address error).

- The composition of the Protocol Data Unit (PDU)**

Command text (or PDU) consists of the main request code (MRC), the sub-request code (SRC), and the data required by these, and these are transferred.

**Service request PDU**



Continuing on from the above MRC and SRC, main response codes (MRES) and sub-response codes (SRES) are transferred to the response frame, and then the data is transferred.

**Service response PDU (normal)**

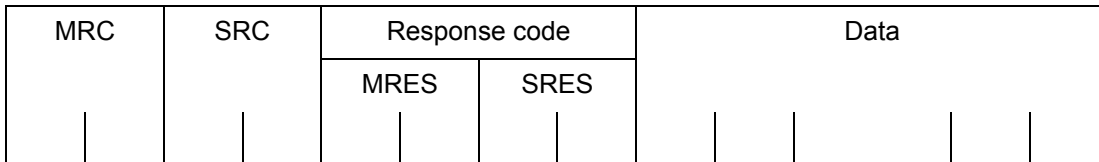

If the specified command text could not be executed, then the service response PDU will consist of only the MRC/ SRC and response code.

## 6.3 CompoWay/F (continued)

### ● Type code

The type codes used with this product are as follows.

#### ■ Variable area

Variable type code	Description
C0	The measured values

#### ■ Parameter area

Variable type code	Description
C000	The parameter values for various settings

### ● List of services

MRC	SRC	Service name	Processing
01	01	Read variable area	Variable area is read.
02	01	Read parameter area	Parameter area is read.
02	02	Write parameter area	The parameter area is written.
05	03	Read unit properties	The model and the communication buffer size are read.
06	01	Read controller status	Operating status is read.
08	01	Echo back test	Echo back test is performed.
30	05	Command	Operations are performed according to commands.

## 6.3 CompoWay/F (continued)

### ● List of response codes

#### When normal end

code	Name	Description	Priority
0000	Normal end	No error.	None

#### When an error occurs

code	Name	Description	Priority
0401	Unsupported command	This is an unsupported service function.	1
1001	Over command length	The command length is too long.	2
1002	Insufficient command length	The command is not long enough.	3
1003	Mismatched element and data numbers	There is a mismatch between the number of elements and the number of pieces of data.	6
1100	Parameter error	The parameter value is unsupported.	8
1101	Area type error	An unsupported area type has been specified.	4
1103	Start writing address out of range error	The value of the start writing address is out of range.	5
110B	Response length too long	The length exceeds the communications buffer.	7
2203	Operation error	Cannot process the command.	10
3000	Status error (error is occurring)	The unit is malfunctioning.	11
3003	Read only	Writing to the variable area.	9

## 6.3 CompoWay/F (continued)

### ● Service details

Addresses, numbers of elements, and data are shown in hexadecimal notation.

#### ■ Variable area read (0101)

Variable area is read.

##### Service request PDU

MRC		SRC		Variable Type		Start reading address				Bit Position		Number of elements			
0	1	0	1	C	0					0	0				
2		2		2		4				2					

##### Service response PDU (normal)

MRC		SRC		Response code				Read data (For the number of elements)							
0	1	0	1												
2		2		4				8×n(n:0 to 25)							

- **Variable type and address to start reading**

Refer to "6.4 Address map" for the different variable types and the start reading address. (⇒ 98)

- **Bit position**

This product does not support bit access. Fixed at "00".

- **Number of elements**

Specifies the number of variables to read.

Number of elements	Processing
0000	Nothing is read and the end is normal. (Read data is not appended to the service response PDU)
0001 to 0019	A maximum of 25 (H'19) are read and the end is normal.

- When the start reading address is an address within the variable area and the end reading address (the start reading address plus the number of elements) exceeds the valid addresses of the variable area, then if the number of data up to the end of the end address is within the range specified by the number of elements, reading is done and the end is normal. In this case, the number of data read will be fewer than the number of elements specified in the command. Further, if the start reading address is outside of the variable area, there will be a start address out of range error.

- **Response code**

Refer to "List of response codes" for details about each response code. (⇒ 88)

## 6.3 CompoWay/F (continued)

### Example of read variable area communications

This example shows how to read the two measurement values with one command when the measurement is of voltage 1 at 103.7V and voltage 2 at 103.6V

#### Command

"(H'02)	<u>00</u>	<u>00</u>	<u>0</u>	<u>01</u>	<u>01</u>	<u>C0</u>	<u>0000</u>	<u>00</u>	<u>0002</u>	<u>(H'03)</u>	<u>(H'42)</u> "
STX	Commu- nication address	Sub- address	SID	MRC	SRC	Variable Type	Start reading address	Bit Positio- n	Number of elements	ETX	BCC

#### Response

"(H'02)	<u>00</u>	<u>00</u>	<u>00</u>	<u>01</u>	<u>01</u>	<u>0000</u>	<u>0000040D</u>	<u>0000040C</u>	<u>(H'03)</u>	<u>(H'02)</u> "
STX	Commu- nication address	Sub- address	Exit code	MRC	SRC	Respon- se code	Voltage 1	Voltage 2	ETX	BCC

This product converts measured values to hexadecimal without decimal points for response. H'0000040D would be 1037 (in decimal).

## 6.3 CompoWay/F (continued)

### ■ Read parameter area (0201)

Parameter area is read.

#### Service request PDU

MRC	SRC	Parameter type	Start reading address	Number of elements
0   2	0   1	C   0   0   0		
2	2	4	4	4

#### Service response PDU (normal)

MRC	SRC	Response code	Parameter Type	Start reading address	Number of elements	Read data (For the number of elements)
0   2	0   1					
2	2	4	4	4	4	8×n (n: 0 to 25)

- **Variable type and address to start reading**  
Refer to "Address map" for the variable types and the start reading address.(⇒ 98)
- **Number of elements**  
Specifies the number of variables to read.

Number of elements	Processing
8000	Nothing is read and the end is normal. (Read data is not appended to the service response PDU)
8001 to 8019	A maximum of 25 (H'19) are read and the end is normal. • The uppermost but must always be set to 1.

- When the start reading address is an address within the variable area and the end reading address (the start reading address plus the number of elements) exceeds the valid addresses of the variable area, then if the number of data up to the end of the end address is within the range specified by the number of elements, reading is done and the end is normal. In this case, the number of data read will be fewer than the number of elements specified in the command. Further, if the start reading address is outside of the variable area, there will be a start address out of range error.
- **Response code**  
Refer to "List of response codes" for details about each response code. (⇒ 88)

## 6.3 CompoWay/F (continued)

### Example of read parameter area communications

This example shows how to read two settings with one command where the phase and wire type is set to 1-phase 2-wire and the communications address is 10

Command

"(H'02)	<u>10</u>	<u>00</u>	<u>0</u>	<u>02</u>	<u>01</u>	<u>C000</u>	<u>1000</u>	<u>8002</u>	<u>(H'03)</u>	<u>(H'49)"</u>
STX	Commu- nication address	Sub- address	SID	MRC	SRC	Parameter Type	Start reading address	Number of element s	ETX	BCC

Response

"(H'02)	<u>10</u>	<u>00</u>	<u>00</u>	<u>02</u>	<u>01</u>	<u>0000</u>	<u>1000</u>	<u>8002</u>		
STX	Commu- nication address	Sub- address	Exit code	MRC	SRC	Parameter Type	Start reading address	Number of element s		
						<u>00000000</u>	<u>0000000A</u>		<u>(H'03)</u>	<u>(H'08)"</u>
						Phase and wire type	Communication address		ETX	BCC

- If the phase and wire type is 1-phase 2-wire, H'00000000 is read. The communications address will be H'0000000A=10 (decimal).

## 6.3 CompoWay/F (continued)

### ■ Write parameter area (0202)

Writing to the parameter area starts.

This service is made valid by using a command to move to the settings mode. The content written is reflected by moving to the measuring mode in response to an instruction after writing of the parameters.

#### Service request PDU

MRC	SRC	Parameter type	Start writing address	Number of elements	Written data (For the number of elements)
0   2	0   2	C   0   0   0			
2	2	4	4	4	8×n(n:0 to 25)

#### Service response PDU (normal)

MRC	SRC	Response code
0   2	0   2	
2	2	4

- **Variable type and address to start writing**

Refer to "Address map" for the different variable types and the start writing address.(⇒ 98)

- **Number of elements**

Specifies the number of variables to be written.

Number of elements	Processing
8000	Nothing is written and the end is normal. (Written data is not appended to the service response PDU)
8001 to 8019	A maximum of 25 (H'19) are written and the end is normal. • The uppermost bit must always be set to 1.

- When the start writing address is an address within the variable area and the end writing address (the start writing address plus the number of elements) exceeds the valid addresses of the variable area, then if the number of data up to the end of the end address is within the range specified by the number of elements, writing is done and the end is normal. In this case, the number of data written will be fewer than the number of elements specified in the command. Further, if the start writing address is outside of the variable area, there will be a start address out of range error.
- Response code  
Refer to "List of response codes" for details about each response code. (⇒ 88)

### 6.3 CompoWay/F (continued)

**Example of write parameter communications**

Example of a command to set the CT secondary side to 1A

Command

"(H'02)	00	00	0	02	02	C000	100A	8001	00000000	(H'03)	(H'48)"
STX	Commu- nication address	Sub- address	SID	MRC	SRC	Parameter Type	Start writing address	Number of element s	Written data CT used:1A	ETX	BCC

Response

"(H'02)	00	00	00	02	02	0000	(H'03)	(H'03)"
STX	Commu- nication address	Sub- address	Exit code	MRC	SRC	Response code	ETX	BCC

The address for the CT secondary side is 100A, and setting the used CT to 1A is H'00000000.

■ **Read unit properties (0503)**

The model and buffer size are read.

**Service request PDU**

MRC	SRC
0   5	0   3
2	2

**Service response PDU**

MRC	SRC	Response code	Model	Buffer size
0   5	0   3			0   0   E   6
2	2	4	10	4

• **Model**

The model is displayed in 10 bytes of ASCII code. Space codes are used if the model doesn't take up 10 bytes. For example: This will be as follows for model KM-N2-FLK

K	M	-	N	2	-	F	L	K	
---	---	---	---	---	---	---	---	---	--

• **Buffer size**

The buffer size 230 is read as "00E6" (fixed value).

• **Response code**

Refer to "List of response codes" for details about each response code. (⇒ 88)

## 6.3 CompoWay/F (continued)

### ■ Controller status read (0601)

Reads operational state and error status.

#### Service request PDU

MRC	SRC
0   6	0   1
2	2

#### Service response PDU (normal)

MRC	SRC	Response code	Operational state	Related information
0   6	0   1			
2	2	4	2	2

#### • Operational state

Operational state	Description
00	The unit is measuring without error.
01	An error has occurred and measuring has stopped.

#### • Related information

Bit position	Meaning	Description
B0(LSB)	Memory error	0: no error, 1: error
B1	VR open phase warning	0: No warning, 1: Warning
B2	VS open phase warning	0: No warning, 1: Warning
B3	VT open phase warning	0: No warning, 1: Warning
B4	Input frequency warning	0: No warning, 1: Warning
B5	Phase sequence error	0: No warning, 1: Warning
B6	Active power is a negative value	0: No warning, 1: Warning
B7(MSB)	Pulse output warning	0: No warning, 1: Warning

- If there is one pulse output warning from amongst OUT1 to 4, the B7 will be 1.

#### • Response code

Refer to "List of response codes" for details about each response code. (⇒ 88)

#### Example of bit information for related information

If a memory error (B0) occurs, the bits in the related information of the status information appear as follows. Displayed as "01" in the PDU.

B7	B6	B5	B4	B3	B2	B1	B0
0	0	0	0	0	0	0	1

## 6.3 CompoWay/F (continued)

### ■ Echo back test (0801)

Echo back test is performed.

#### Service request PDU

MRC		SRC		Test data															
0	8	0	1																
2		2		0 to 200															

#### Service response PDU (normal)

MRC		SRC		Response code				Test data											
0	8	0	1																
2		2		4				0 to 200											

- **Test data**

Set any test data within the range 0 to 200.

- **Response code**

Refer to "List of response codes" for details about each response code. (⇒ 88)

## 6.3 CompoWay/F (continued)

### ■ Command (3005)

Used when remotely controlling the unit.

#### Service request PDU

MRC		SRC		Instruction code	Related information
3	0	0	5		
2		2		2	2

#### Service response PDU (normal)

MRC		SRC		Response code	
3	0	0	5		
2		2		4	

- **List of command codes and related information**

Related information is fixed at 00.

Instruction code	Related information	Instruction details
03	00	Resets any active energy values that can be reset (individual units)
04	00	Move to measuring mode
07	00	Moving to setting mode
09	00	Initialize (any active energy values that can be reset and setting values)

- **Response code**

Refer to "List of response codes" for details about each response code. (⇒ 88)

## 6.4 Address map

### • List of variable areas (measurement values)

Used when remotely controlling the unit.

address		Item		R/W
Modbus	CompoWay/F	Parameter name	Monitor value	
0000	0000	Voltage 1 (V)	H'00000000 to H'0098967F (0 to 9999999) 10 times the voltage	R
0002	0001	Voltage 2 (V)		R
0004	0002	Voltage 3 (V)		R
0006	0003	Current 1 (A)	H'00000000 to H'05F5E0FF (0 to 99999999) 1000 times the current	R
0008	0004	Current 2 (A)		R
000A	0005	Current 3 (A)		R
000C	0006	Power factor	H'FFFFFF9C to H'00000064 (-100 to 100) 100 times the power factor	R
000E	0007	Frequency (Hz)	H'000001C2 to H'0000028A (450 to 650) 10 times the frequency	R
0010	0008	Active power (W)	H'80000000 to H'7FFFFFFF (-214748368 to 2147483647) 10 times the active and reactive power	R
0012	0009	Reactive power (Var)		R
0014	000A	Voltage V1-V2 (V)	H'00000000 to H'0098967F (0 to 9999999) 10 times the voltage	R
0016	000B	Voltage V1-V3 (V)		R
0018	000C	Voltage V2-V3 (V)		R
0200	0100	Active energy (import) (not resettable) (Wh)	H'00000000 to H'3B9AC9FF (0 to 999999999) Value that is 1 times each value	R
0202	0101	Active energy (export) (not resettable) (Wh)		R
0204	0102	Reactive energy (import) (not resettable) (Varh)		R
0206	0103	Reactive energy (export) (not resettable) (Varh)		R
0208	0104	Cumulative total reactive power (not resettable) (Varh)		R
020A	0105	T1 Active energy (import) (not resettable) (Wh)		R
020C	0106	T2 Active energy (import) (not resettable) (Wh)		R
020E	0107	T3 Active energy (import) (not resettable) (Wh)		R
0210	0108	T4 Active energy (import) (not resettable) (Wh)		R
0220	0110	Active energy (import) (not resettable) (kWh)		R
0222	0111	Active energy (export) (not resettable) (kWh)		R
0224	0112	Reactive energy (import) (not resettable) (kVarh)		R
0226	0113	Reactive energy (export) (not resettable) (kVarh)		R

## 6.4 Address map (continued)

address		Item		R/W
Modbus	CompoWay/F	Parameter name	Monitor value	
0228	0114	Cumulative total reactive power (not resettable) (kVarh)	H'00000000 to H'3B9AC9FF (0 to 999999999) Value that is 1 times each value	R
022A	0115	T1 Active energy (import) (not resettable) (kWh)		R
022C	0116	T2 Active energy (import) (not resettable) (kWh)		R
022E	0117	T3 Active energy (import) (not resettable) (kWh)		R
0230	0118	T4 Active energy (import) (not resettable) (kWh)		R
0240	0120	Active energy (import) (resettable) (Wh)		R
0242	0121	Active energy (export) (resettable) (Wh)		R
0244	0122	Reactive energy (import) (resettable) (Varh)		R
0246	0123	Reactive energy (export) (resettable) (Varh)		R
0248	0124	Cumulative total reactive power (resettable) (Varh)		R
024A	0125	T1 Active energy (import) (resettable) (Wh)		R
024C	0126	T2 Active energy (import) (resettable) (Wh)		R
024E	0127	T3 Active energy (import) (resettable) (Wh)		R
0250	0128	T4 Active energy (import) (resettable) (Wh)		R
0260	0130	Active energy (import) (resettable) (kWh)		R
0262	0131	Active energy (export) (resettable) (kWh)		R
0264	0132	Reactive energy (import) (resettable) (kVarh)		R
0266	0133	Reactive energy (export) (resettable) (kVarh)		R
0268	0134	Cumulative total reactive power (resettable) (kVarh)		R
026A	0135	T1 Active energy (import) (resettable) (kWh)		R
026C	0136	T2 Active energy (import) (resettable) (kWh)		R
026E	0137	T3 Active energy (import) (resettable) (kWh)		R
0270	0138	T4 Active energy (import) (resettable) (kWh)		R
0300	0180	Conversion value (e.g. JPY)		R
0302	0181	Conversion value (e.g. K.JPY)		R

- Current 2 is the value measured by either CT2 or CT4.
- Current 3 is the measured value calculated from current 1 and current 2.
- Figures with units of Wh and kWh can be read to the cumulative value. You can use the most easy to read according to the changes in the cumulative value.
- Negative numbers are shown as two's complement.
- Only the consecutive address items can be read in a batch.

## 6.4 Address map (continued)

## ● Parameter area list

Address		Type	Parameter name	Setting (monitor) value	R/W
Modbus	CompoWay/F				
2000	1000	Unit Individual setting	Phase and wire type	H'00000000:1P2W H'00000001:1P3W H'00000002:3P3W H'00000003:1P2W2 H'00000004:1P3W2 H'00000005:3P4W	R/W
2002	1001		Communication address	H'00000001 to H'00000063 (1 to 99): Modbus H'00000000 to H'00000063 (0 to 99): when CompoWay/F	R
2010	1008		Pulse output ON/OFF	H'00000000:OFF H'00000001:ON	R/W
2012	1009		Voltage selected	H'00000000:V_R H'00000001:V_T H'00000002:V_R-T	R/W
2014	100A		CT secondary side current	H'00000000:1A H'00000001:5A	R/W
2016	100B		CT primary side current	H'00000000 to H'0001869F (0 to 99999) 1 times the current	R/W
2200	1100	Common settings	Protocol	H'00000000:CompoWay/F H'00000001:Modbus	R/W
2202	1101		Communication speed	H'00000000:1200bps H'00000001:2400bps H'00000002:4800bps H'00000003:9600bps H'00000004:19200bps H'00000005:38400bps	R/W
2204	1102		Data length	H'00000000:7bit H'00000001:8bit	R/W
2206	1103		Stop bit	H'00000000:1bit H'00000001:2bit	R/W
2208	1104		Parity	H'00000000:NONE H'00000001:ODD H'00000002:EVEN	R/W
220A	1105		Transmission wait time	H'00000000 to H'00000063 (0 to 99) Wait time in msec units	R/W
220C	1106		Pulse output units	H'00000000:1Wh H'00000001:10Wh H'00000002:100Wh H'00000003:1kWh H'00000004:5kWh H'00000005:10kWh H'00000006:50kWh H'00000007:100kWh	R/W

## 6.4 Address map (continued)

address		Type	Parameter name	Setting (monitor) value	R/W
Modbus	CompoWay/F				
220E	1107	Common settings	VT ratio	H'00000064 to H'0001869F (100 to 99999) 100 times the VT ratio	R/W
2210	1108		Conversion factor	H'00000000 to H'0001869F (0 to 99999) 1000 times the factor	R/W
2212	1109		Conversion units (characters)	Characters in hexadecimal display of 3 characters worth of ASCII code	R/W
2214	110A		Automatic LCD off time	H'00000000:OFF H'00000001:1 minute H'00000002:5 minutes H'00000003:10 minutes	R/W
2218	110C		Alarm ON/OFF	H'00000000:OFF H'00000001:ON	R/W
221A	110D		Tariff ON/OFF	H'00000000:OFF H'00000001:ON	R/W
221C	110E		Current tariff	H'00000000:T1 H'00000001:T2 H'00000002:T3 H'00000003:T4	R/W
2400	1200		Model 1 (KM-N)	The model is shown in ASCII code, with the first 1 to 4 characters starting on the left when the display is 12 characters aligned to the left.	R
2402	1201		Model 2 (2-FL)	The model is shown in ASCII code, with characters 5 to 8 starting on the left when the display is 12 characters aligned to the left.	R
2404	1202		Model 3 (K (sp)(sp)(sp))	The model is shown in ASCII code, with characters 9 to 12 starting on the left when the display is 12 characters aligned to the left. (sp) indicates a space	R
2406	1203		Software version	For example: H'00000100→Ver1.0.0	R
2408	1204		Status information	Refer "Controller status read (0601)"	R
240A	1205		Buffer size	H'000000E6 (230 fixed)	R

## 7.1 Warnings

Warnings come as errors and alarms. The types of errors and alarms are described below.

Warning type		Description	Display		Action to take
			LCD display	LED display	
Error	Setting value error	Internal memory corrupted	E-M1	Error LED flashing	Repair is necessary. Contact the place of purchase or the manufacturer.
	Measured value error	Internal memory corrupted	E-M2		
	Calibration value error	A calibration value is corrupted	E-M3		
Alarm	Input frequency warning	Measured frequency is outside rated ranges	A-F1	Alarm LED flashing	Input the power and voltage with the frequency within the rated ranges.
	VR open phase warning	The voltage has not reached the rated value.	A-VR		There may be an issue such as the wiring to the voltage input terminal being loose, so that voltage does not reach the rated value for each phase due to miss-wiring. Redo the wiring correctly to match the phase and wire type you are using.
	VS open phase warning		A-VS		
	VT open phase warning		A-VT		
	Phase sequence error	The phase sequence is wrong for 3-phase 4-wire, 1-phase 3-wire, or 3-phase 3-wire connection.	A-W2		The wiring to the voltage input terminal does not match the phase and wire type you are using. Redo the wiring correctly to match the phase and wire type you are using.
	Active power is a negative value	Active power is a negative value. (The voltage and current phase may not match due to incorrect wiring.)	A-W3		Redo the wiring correctly according to the situation.*
	Pulse 1 Output warning	<ul style="list-style-type: none"> <li>Pulse is output again while a pulse is being output</li> <li>Pulse is output during a period when the pulse is off</li> </ul>	A-P1		Change the pulse output unit so that pulses are not output while other pulses are being output.
	Pulse 2 Output warning		A-P2		
	Pulse 3 Output warning		A-P3		
	Pulse 4 Output warning		A-P4		

\* If you intend to meter negative values (exported energy), then no correction is necessary. Metering continues normally even when a warning is displayed (A-W3). Set "Warning ON/OFF (MENU 0B)" to OFF if you do not require the warnings (A-F1, A-VR, A-VS, A-VT, A-W2, A-W3). (⇒ 68)

※ To cancel the alarm, take the actions described to remove the cause, then switch the power on again.

## 7.2 Troubleshooting

Check if an issue is covered by the following items if the product doesn't seem to be working correctly.

Phenomena	Description	Action to take	Page
The main unit doesn't start	Is the power LED off?	The unit isn't being supplied with power. Check that the voltage terminals have been wired and that voltage within the rated range is being supplied.	⇒ 29
	Is the power LED lit but the LCD display is off?	The power saving mode is working. The LCD will light again when you press any of the switches.	⇒ 67
Cannot measure voltage	Are the voltage connections and phase correct?	Check that the voltage connection matches the phase and wire type you have selected.	⇒ 38
	Have you selected 1P2W2 (1-phase 2-wire voltage selected) or 1P3W2 (1-phase 3-wire composite) as the phase and wire type?	If you have selected 1P2W2 or 1P3W2 as the phase and wire type, set the correct voltage allocation for the branching 1-phase 2-wire.	⇒ 63
Cannot measure current	Is the CT connected?	Connect the CT to the main unit. Also check if the CT has become separated from the electric wire.	⇒ 27
	Is the connection positioning of the measuring circuits and the CT terminals correct?	Circuit A uses CTs 1, 2, or 3, circuit B uses CT 2, circuit C uses CT 3 or 4, and circuit D uses CT 4. Connect properly according to the connection diagrams.	⇒ 27
Voltage and current can be measured, but power cannot be measured	Are the CT fitted back to front?	If negative electricity is being measured, there is a chance that all of the fitted CTs have been fitted back to front. Alternatively, if electricity is being measured is a value near 0, there is a chance that one of the fitted CTs has been fitted back to front.	⇒ 31
	Is the voltage phase correct?	Power cannot be correctly measured if the phase of the voltage is not correct. If the function for warning about miss-wiring is on, "A-VR", "A-VS", "A-VT" and "A-W2" are displayed. Wire correctly.	⇒ 38, 68
	Have you selected 1P2W2 (1-phase 2-wire voltage selected) or 1P3W2 (1-phase 3-wire composite) as the phase and wire type?	If you have selected 1P2W2 or 1P3W2 as the phase and wire type, set the correct voltage allocation for the branching 1-phase 2-wire.	⇒ 63

## 7.2 Troubleshooting (continued)

Phenomena	Description	Action to take	Page
There is a large discrepancy in measured values	Does the selected phase and wire type match the wiring?	Wire correctly.	⇒ 38
	Does the CT match the secondary current and primary current settings of the CT?	Check the secondary current and primary current of the CT you are using and set the right values.	⇒ 13
		If you are using multi-circuit metering, the secondary current and primary current of all of the circuits you are using need to be set.	⇒ 56
		With multi-circuit metering, CT1 corresponds to circuit A, CT2 corresponds to circuits A and B, CT3 corresponds to circuits A and C, and CT4 corresponds to circuits C and D.	⇒ 56
	Has the input exceeded the input range of the CT?	Check the secondary current and primary current of the CTs you are using and use CTs that have appropriate rated current values for the circuit being measured.	⇒ 13
	Is the phase and wire type setting correct?	Check the phase and wire type for the measuring circuits and make the correct settings.	⇒ 54
Pulse is not output	Is the pulse output wiring correct?	Wire correctly.	⇒ 32
	Is the pulse output set?	You need to set which of the OUT1/OUT2/OUT3/OUT4 pulse output terminals to output from. The default is for all of them to be OFF (no pulse output). Make sure they have been set.	⇒ 62
	Is the pulse output unit too large for the active energy?	If the pulse output units are too large for the increases in active energy, the interval between pulse outputs will be wide. Reduce the pulse output units.	⇒ 62

## 7.2 Troubleshooting (continued)

Phenomena	Description	Action to take	Page
RS-485 communications not possible	Is the wiring correct?	Wire correctly.	⇒ 36
	Are the communications settings correct?	Check that the communications settings between this product and the host system match.	⇒ 59
	Have you connected fewer units than the maximum number of units you can connect on the same line?	The maximum number of units you can connect when the protocol is Modbus is 99 units, and when the protocol is CompoWay/F the maximum is 31. (The parent device is not included in either of these numbers.)	⇒ 36
	Have you set separate communications addresses for each circuit?	Make sure the communications addresses do not duplicate across circuits when using multi-circuit metering. Also, if you connect several of these products, allocate all of the circuits different communications addresses.	⇒ 56
I have forgotten the password and cannot get into the setting mode	—	Contact the place of purchase or the manufacturer.	—

## 8.1 Specifications

### ■ Main unit specifications

Item	Description
Rated input voltage (Common voltage and current)	3-phase 4-wire: AC100 to 277V (L-N), AC173 to 480VAC (L-L) 1-phase 2-wire: AC100 to 277V 1-phase 3-wire: AC100 to 240V (L-N), AC200 to 480VAC (L-L) 3-phase 3-wire: AC173 to 480VAC (L-L)
Rated frequency	50/60Hz
Allowable power supply voltage range	Rated input voltage 85 to 115%
Power consumption	7VA or less
Ambient operating temperature	-25 to 55°C (with no icing or condensation)
Ambient operating humidity	25 to 85%RH
Storage temperature	-25 to 85°C(with no icing or condensation)
Storage humidity	25 to 85%RH
Dielectric strength voltage	1) Between electronic circuitry and case: AC2200V for 1 minute 2) Between the set of power and voltage inputs and the set of communication terminals and pulse output terminals: AC2200V for 1 minute
Insulation resistance	1) Between electronic circuitry and case: 20MΩ max. (at DC500V mega) 2) Between the set of power and voltage inputs and the set of communication terminals and pulse output terminals: 20MΩ max. (at DC500V mega)
Vibration resistance	Single amplitude: 0.1 mm, Acceleration: 15m/s <sup>2</sup> , Frequency: 10 to 150 Hz 10 sweeps for eight minutes along the three axes
Shock resistance	150m/s <sup>2</sup> , 3 times each in the up, down, left, right, forward, and back directions
Electromagnetic environment	Industrial electromagnetic environment (EN/IEC 61326-1 Table 2)
Display and Operation	LED, LCD display, buttons (Up, down, <</MODE, ENTER, ESC) Rotary switch (one each for units of 10 and units of 1) Reset switch
Weight	Approximately 350g (main unit), approximately 450g (when in packaging)
Mounting	Attaching the DIN rail
Altitude	Under 2000 m
Installation environment	Overvoltage category and measurement category: II,, Pollution level: 2
Applicable standards	EN61010-2-030, EN61326-1, UL61010-1
Supplied Accessories	Instruction Manual, compliance sheet

## 8.1 Specifications (continued)

### ■ Input specifications

Item	Description
Applicable circuit type	3-phase 4-wire, 1-phase 2-wire, 1-phase 3-wire, 3-phase 3-wire
Number of measuring circuits	3-phase 4-wire : maximum of 1 circuit 1-phase 2-wire: : maximum of 4 circuits 1-phase 3-wire, 3-phase 3-wire : maximum of 2 circuits
Connectable CTs	Generic CT (secondary rating: 1A/5A)*
CT secondary side rated current	1A
Maximum current for CT secondary side	6A

\* You cannot use the CT dedicated for use with the Omron KM series (model series KM-NCT, model series KM20-CTF, etc.). Use a generic CT whose secondary output is 1A or 5A.

### ■ Output specifications

Item	Description
Pulse output (Active energy)	Number of output points : 4 (PhotoMOS relay outputs)
	Output capacity : DC40V, 50mA or less
	Residual voltage when ON : Less than 1.5V (when output current is 50mA)
	Current leakage when OFF : 0.1mA maximum
	Output units : 1, 10, 100, 1k, 5k, 10k, 50k, 100k (Wh)
Pulse ON time : 500ms fixed	
RS-485	Protocol : Modbus(RTU), CompoWay/F
	Sync method : Asynchronous
	Communication speed : 38400, 19200, 9600, 4800, 2400, 1200bps
	Maximum transmission distance : 1200m
	Maximum number of devices connected : 99 (Modbus), 31 (CompoWay/F)

### ■ Measurement specifications

Item	Description
Active power	0.5%* (IEC62053-22 class 0.5S) **
Reactive power	2% *(IEC62053-23 class 2) **
Measurement frequency	80ms (at 50Hz), 66.7ms (at 60Hz)
Functions	Simple measurement, conversion

\* This does not include the measuring error margin of the generic CT.

\*\*IEC62053 is an international standard dealing with electricity metering.

## 8.1 Specifications (continued)

### ■ Dedicated CT specifications

Model	KM-NCT-E100A	KM-NCT-E250A	KM-NCT-E500A
Rated primary current: $I_n$	100 A	250 A	500 A
Rated secondary current: $I_s$	1 A		
Rated frequency	50/60 Hz		
Overcurrent withstand capability (continuous)	1.2 $I_n$		
Overcurrent withstand capability (1 sec)	4 $I_n$		
Output characteristics	±3% FS	±1% FS	
Phase error	±180 minutes (1.0 $I_n$ ) ±240 minutes (0.2 $I_n$ )	±60 minutes (1.0 $I_n$ ) ±90 minutes (0.2 $I_n$ )	
Rated load	1 VA		
Insulation resistance	100M $\Omega$ min. (at DC500V mega) between core and all output terminals		
Dielectric strength voltage	AC2300V, 1 minute between core and all output terminals		
Weight	Approx. 170g	Approx. 175g	Approx. 290g
Maximum wire diameter	24 dia.	24 dia.	36 dia.
Output overvoltage protection	Built-in clamp element		
Operating temperature and humidity range	-20 to 55°C, relative humidity: 85% max. with no condensation		
Storage temperature and humidity range	-30 to 90°C, relative humidity: 85% max. with no condensation		
Applicable standards *	EN61010-1, EN61010-2-030, EN61326-1		
Installation environment	Overvoltage category and measurement category: II, Pollution level: 2		

\* Only applied when attached to the main unit.

\* UL standards are not supported.

## 8.2 ASCII code table

Binary	Decimal	Hexadecimal	Character	Binary	Decimal	Hexadecimal	Character
0000000	0	0	NUM	0100000	32	20	SP
0000001	1	1	SHO	0100001	33	21	!
0000010	2	2	STX	0100010	34	22	"
0000011	3	3	ETX	0100011	35	23	#
0000100	4	4	EOT	0100100	36	24	\$
0000101	5	5	ENQ	0100101	37	25	%
0000110	6	6	ACK	0100110	38	26	&
0000111	7	7	BEL	0100111	39	27	'
0001000	8	8	BS	0101000	40	28	(
0001001	9	9	TAB	0101001	41	29	)
0001010	10	A	LF	0101010	42	2A	*
0001011	11	B	VT	0101011	43	2B	+
0001100	12	C	FF	0101100	44	2C	,
0001101	13	D	CR	0101101	45	2D	-
0001110	14	E	SO	0101110	46	2E	.
0001111	15	F	SI	0101111	47	2F	/
0010000	16	10	DEL	0110000	48	30	0
0010001	17	11	DC1	0110001	49	31	1
0010010	18	12	DC2	0110010	50	32	2
0010011	19	13	DE3	0110011	51	33	3
0010100	20	14	DE4	0110100	52	34	4
0010101	21	15	NAK	0110101	53	35	5
0010110	22	16	SYN	0110110	54	36	6
0010111	23	17	ETB	0110111	55	37	7
0011000	24	18	CNL	0111000	56	38	8
0011001	25	19	EM	0111001	57	39	9
0011010	26	1A	SUB	0111010	58	3A	:
0011011	27	1B	ESC	0111011	59	3B	;
0011100	28	1C	FS	0111100	60	3C	<
0011101	29	1D	GS	0111101	61	3D	=
0011110	30	1E	RS	0111110	62	3E	>
0011111	31	1F	US	0111111	63	3F	?

## 8.2 ASCII code table (continued)

Binary	Decimal	Hexadecimal	Character	Binary	Decimal	Hexadecimal	Character
1000000	64	40	@	1100000	96	60	`
1000001	65	41	A	1100001	97	61	a
1000010	66	42	B	1100010	98	62	b
1000011	67	43	C	1100011	99	63	c
1000100	68	44	D	1100100	100	64	d
1000101	69	45	E	1100101	101	65	e
1000110	70	46	F	1100110	102	66	f
1000111	71	47	G	1100111	103	67	g
1001000	72	48	H	1101000	104	68	h
1001001	73	49	I	1101001	105	69	i
1001010	74	4A	J	1101010	106	6A	j
1001011	75	4B	K	1101011	107	6B	k
1001100	76	4C	L	1101100	108	6C	l
1001101	77	4D	M	1101101	109	6D	m
1001110	78	4E	N	1101110	110	6E	n
1001111	79	4F	O	1101111	111	6F	o
1010000	80	50	P	1110000	112	70	p
1010001	81	51	Q	1110001	113	71	q
1010010	82	52	R	1110010	114	72	r
1010011	83	53	S	1110011	115	73	s
1010100	84	54	T	1110100	116	74	t
1010101	85	55	U	1110101	117	75	u
1010110	86	56	V	1110110	118	76	v
1010111	87	57	W	1110111	119	77	w
1011000	88	58	X	1111000	120	78	x
1011001	89	59	Y	1111001	121	79	y
1011010	90	5A	Z	1111010	122	7A	z
1011011	91	5B	[	1111011	123	7B	{
1011100	92	5C	\(¥)	1111100	124	7C	
1011101	93	5D	]	1111101	125	7D	}
1011110	94	5E	^	1111110	126	7E	~
1011111	95	5F	_	1111111	127	7F	DEL

## 8.3 14 segment displays and 7 segment displays

The following are some examples of 14 segment displays and 7 segment displays as shown on the LCD of this product.

(example of 14 segment display)

A B C D E F G H I J K L M N O

P Q R S T U V W X Y Z

1 2 3 4 5 6 7 8 9 0 + - \_ /

(example of 7 segment display)

A B C D

1 2 3 4 5 6 7 8 9 0 -

**OMRON Corporation Industrial Automation Company**  
Kyoto, JAPAN

Contact: [www.ia.omron.com](http://www.ia.omron.com)

**Regional Headquarters**

**OMRON EUROPE B.V.**

Wegalaan 67-69, 2132 JD Hoofddorp  
The Netherlands  
Tel: (31)2356-81-300/Fax: (31)2356-81-388

**OMRON ELECTRONICS LLC**

2895 Greenspoint Parkway, Suite 200  
Hoffman Estates, IL 60169 U.S.A.  
Tel: (1) 847-843-7900/Fax: (1) 847-843-7787

**OMRON ASIA PACIFIC PTE. LTD.**

No. 438A Alexandra Road # 05-05/08 (Lobby 2),  
Alexandra Technopark,  
Singapore 119967  
Tel: (65) 6835-3011/Fax: (65) 6835-2711

**OMRON (CHINA) CO., LTD.**

Room 2211, Bank of China Tower,  
200 Yin Cheng Zhong Road,  
PuDong New Area, Shanghai, 200120, China  
Tel: (86) 21-5037-2222/Fax: (86) 21-5037-2200

**Authorized Distributor:**

© OMRON Corporation 2016-2018 All Rights Reserved.  
In the interest of product improvement,  
specifications are subject to change without notice.

**Cat. No. N200-E1-03**

0518