

Machine Automation Controller

NX-series

NX1P2 CPU Unit

Hardware User's Manual

NX1P2-□□□□□□

NX1P2-□□□□□□□1



CPU Unit



NOTE

- All rights reserved. No part of this publication may be reproduced, stored in a retrieval system, or transmitted, in any form, or by any means, mechanical, electronic, photocopying, recording, or otherwise, without the prior written permission of OMRON.
- No patent liability is assumed with respect to the use of the information contained herein. Moreover, because OMRON is constantly striving to improve its high-quality products, the information contained in this manual is subject to change without notice.
- Every precaution has been taken in the preparation of this manual. Nevertheless, OMRON assumes no responsibility for errors or omissions. Neither is any liability assumed for damages resulting from the use of the information contained in this publication.

Trademarks

- Sysmac and SYSMAC are trademarks or registered trademarks of OMRON Corporation in Japan and other countries for OMRON factory automation products.
- Microsoft, Windows, Excel, and Visual Basic are either registered trademarks or trademarks of Microsoft Corporation in the United States and other countries.
- EtherCAT® is registered trademark and patented technology, licensed by Beckhoff Automation GmbH, Germany.
- ODVA, CIP, CompoNet, DeviceNet, and EtherNet/IP are trademarks of ODVA.
- The SD and SDHC logos are trademarks of SD-3C, LLC.  

Other company names and product names in this document are the trademarks or registered trademarks of their respective companies.

Copyrights

- Microsoft product screen shots reprinted with permission from Microsoft Corporation.
- This product incorporates certain third party software. The license and copyright information associated with this software is available at http://www.fa.omron.co.jp/nj_info_e/.

Introduction

Thank you for purchasing an NX-series CPU Unit.

This manual contains information that is necessary to use the NX-series CPU Unit. Please read this manual and make sure you understand the functionality and performance of the NX-series CPU Unit before you attempt to use it in a control system.

Keep this manual in a safe place where it will be available for reference during operation.

Intended Audience

This manual is intended for the following personnel, who must also have knowledge of electrical systems (an electrical engineer or the equivalent).

- Personnel in charge of introducing FA systems.
- Personnel in charge of designing FA systems.
- Personnel in charge of installing and maintaining FA systems.
- Personnel in charge of managing FA systems and facilities.

For programming, this manual is intended for personnel who understand the programming language specifications in international standard IEC 61131-3 or Japanese standard JIS B 3503.

Applicable Products

This manual covers the following products.

- NX-series CPU Units
NX1P2-□□□□□□
NX1P2-□□□□□□1
- Serial Communications Option Board
NX1W-CIF□□
- Analog I/O Option Board
NX1W-ADB21
NX1W-DAB21V
NX1W-MAB221

Part of the specifications and restrictions for the CPU Units are given in other manuals. Refer to *Relevant Manuals* on page 2 and *Related Manuals* on page 41.

Relevant Manuals

The following table provides the relevant manuals for the NX-series CPU Units. Read all of the manuals that are relevant to your system configuration and application before you use the NX-series CPU Unit.

Most operations are performed from the Sysmac Studio Automation Software. Refer to the *Sysmac Studio Version 1 Operation Manual* (Cat. No. W504) for information on the Sysmac Studio.

Purpose of use	Manual								
	Basic information				NJ/NX-series Motion Control User's Manual	NJ/NX-series CPU Unit Motion Control Instructions Reference Manual	NJ/NX-series CPU Unit Built-in EtherCAT Port User's Manual	NJ/NX-series CPU Unit Built-in EtherNet/IP Port User's Manual	NJ/NX-series Troubleshooting Manual
	NX-series NX1P2 CPU Unit Hardware User's Manual	NJ/NX-series CPU Unit Software User's Manual	Built-in I/O and Option Board User's Manual	NX-series NX1P2 CPU Unit Instructions Reference Manual					
Introduction to NX1P2 CPU Units	●								
Setting devices and hardware									
Using motion control					●				
Using EtherCAT	●					●			
Using EtherNet/IP							●		
Software settings									
Using motion control					●				
Using EtherCAT		●				●			
Using EtherNet/IP							●		
Using the NX1P2 CPU Unit functions			●						
Writing the user program									
Using motion control					●	●			
Using EtherCAT		●		●			●		
Using EtherNet/IP								●	
Programming error processing									●
Using the NX1P2 CPU Unit functions			●						
Testing operation and debugging									
Using motion control					●				
Using EtherCAT		●					●		
Using EtherNet/IP								●	
Using the NX1P2 CPU Unit functions			●						
Learning about error management and corrections									●

Purpose of use	Manual						
	Basic information			Motion Control User's Manual	Motion Control Instructions Reference Manual	Built-in EtherCAT Port User's Manual	Built-in EtherNet/IP Port User's Manual
	NJ/NX-series Hardware User's Manual	NJ/NX-series CPU Unit Software User's Manual	NX-series NX1P2 CPU Unit Built-in I/O and Option Board User's Manual				
Maintenance							
Using motion control				●			
Using EtherCAT	●					●	
Using EtherNet/IP							●

Manual Structure

Page Structure

The following page structure is used in this manual.

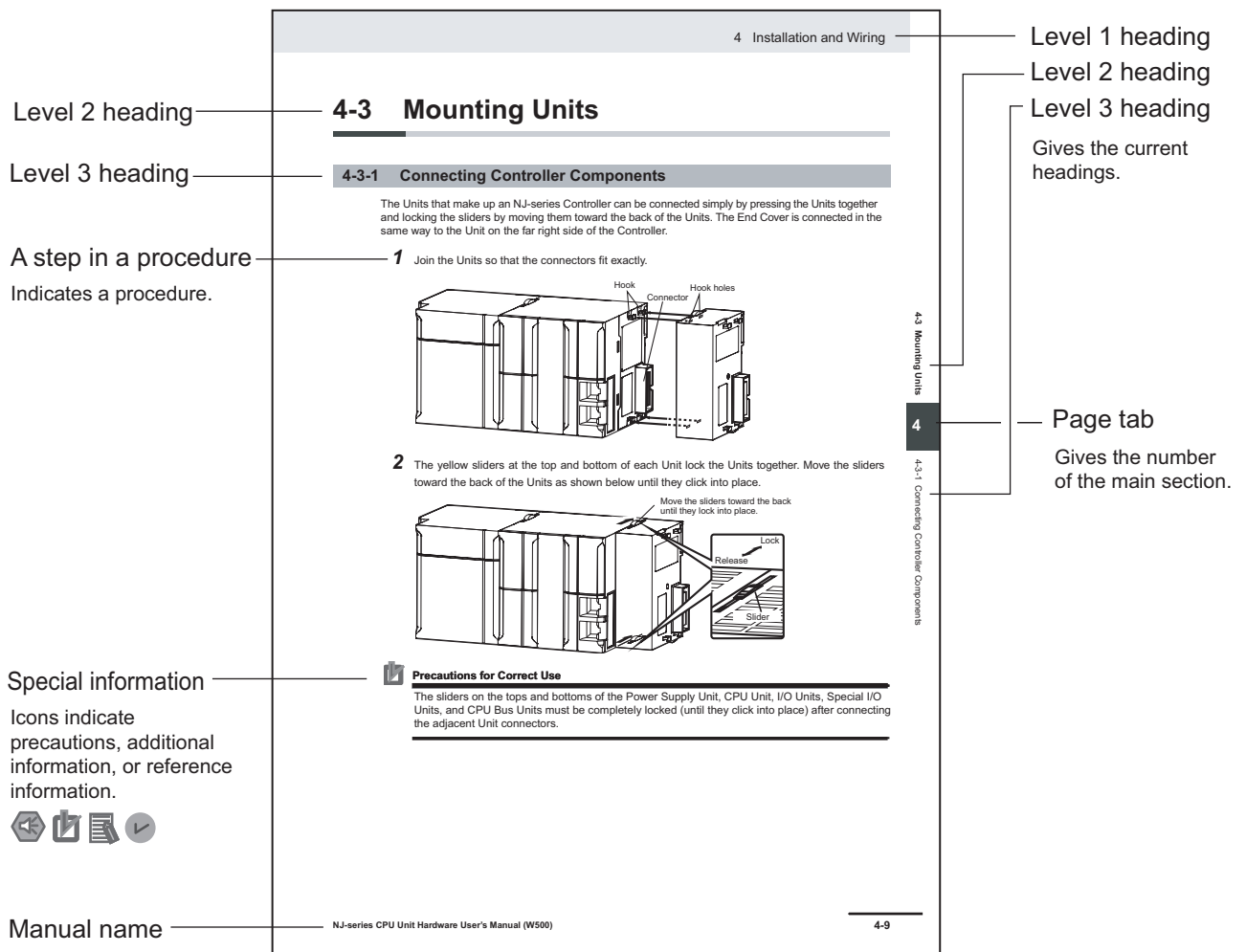

Note This illustration is provided only as a sample. It may not literally appear in this manual.

Special Information

Special information in this manual is classified as follows:



Precautions for Safe Use

Precautions on what to do and what not to do to ensure safe usage of the product.



Precautions for Correct Use

Precautions on what to do and what not to do to ensure proper operation and performance.



Additional Information

Additional information to read as required.
This information is provided to increase understanding or make operation easier.



Version Information

Information on differences in specifications and functionality for CPU Units with different unit versions and for different versions of the Sysmac Studio is given.

Precaution on Terminology

In this manual, "download" refers to transferring data from the Sysmac Studio to the physical Controller and "upload" refers to transferring data from the physical Controller to the Sysmac Studio. For the Sysmac Studio, "synchronization" is used to both "upload" and "download" data. Here, "synchronize" means to automatically compare the data for the Sysmac Studio on the computer with the data in the physical Controller and transfer the data in the direction that is specified by the user.

Sections in this Manual

1	Introduction to NX-series Controllers	1
2	System Configuration	2
3	Configuration Units	3
4	Designing the Power Supply System	4
5	Installation and Wiring	5
6	Troubleshooting	6
7	Inspection and Maintenance	7
A	Appendices	A
I	Index	I

CONTENTS

Introduction	1
Intended Audience	1
Applicable Products	1
Relevant Manuals	2
Manual Structure	4
Page Structure	4
Special Information	5
Precaution on Terminology	5
Sections in this Manual	7
Terms and Conditions Agreement	12
Warranty, Limitations of Liability	12
Application Considerations	13
Disclaimers	13
Safety Precautions	15
Definition of Precautionary Information	15
Symbols	15
WARNING	16
Cautions	18
Precautions for Safe Use	20
Precautions for Correct Use	31
Regulations and Standards	35
Conformance to EU Directives	35
Conformance to UL and CSA Standards	36
Conformance to KC Certification	36
Conformance to Shipbuilding Standards	36
Software Licenses and Copyrights	37
Versions	38
Checking Versions	38
Unit Versions of CPU Units and Sysmac Studio Versions	40
Related Manuals	41
Terminology	44
Revision History	49

Section 1 Introduction to NX-series Controllers

1-1 The NX-series Controller	1-2
1-1-1 Features	1-3
1-1-2 Introduction to the System Configurations	1-6
1-2 Specifications	1-9
1-3 Overall Operating Procedure for the CPU Unit	1-14

1-3-1	Overall Procedure	1-14
1-3-2	Procedure Details.....	1-15

Section 2 System Configuration

2-1	Basic System Configuration	2-2
2-1-1	EtherCAT Network Configuration	2-3
2-1-2	NX Unit Configuration	2-4
2-2	Connecting to the Sysmac Studio.....	2-7
2-3	Network Configuration	2-8

Section 3 Configuration Units

3-1	CPU Units	3-2
3-1-1	Models and Specifications	3-2
3-1-2	Part Names and Functions.....	3-5
3-1-3	Operation Status Indicators.....	3-7
3-1-4	Terminal Blocks	3-12
3-1-5	Battery.....	3-18
3-1-6	ID Information Indication	3-20
3-2	SD Memory Cards	3-21
3-2-1	Models and Specifications	3-21
3-2-2	Purpose	3-21
3-3	Serial Communications Option Board	3-22
3-3-1	Models and Specifications	3-22
3-3-2	Purpose.....	3-23
3-3-3	Part Names and Functions.....	3-23
3-4	Analog I/O Option Board	3-26
3-4-1	Models and Specifications	3-26
3-4-2	Purpose.....	3-27
3-4-3	Part Names and Functions.....	3-27
3-5	Power Supply-related Units	3-31
3-6	NX Units	3-32
3-7	Sysmac Studio	3-33
3-7-1	Model Numbers.....	3-33
3-7-2	Connection	3-33

Section 4 Designing the Power Supply System

4-1	Power Supply System and Design Concepts.....	4-2
4-1-1	Power Supply System and Types of Power Supplies	4-2
4-1-2	NX-series Power Supply-related Units.....	4-4
4-1-3	Design Concepts for Power Supply to the CPU Rack.....	4-6
4-2	Designing the NX Unit Power Supply System.....	4-7
4-2-1	Procedure for Designing the NX Unit Power Supply System.....	4-7
4-2-2	Calculation Example for the NX Unit Power Supply.....	4-8
4-3	Designing the I/O Power Supply System.....	4-10
4-3-1	I/O Power Supply Method	4-10
4-3-2	Designing the I/O Power Supply from the NX Bus.....	4-11
4-3-3	Designing the I/O Power Supply from External Sources.....	4-16
4-3-4	Designing I/O Power Supply for the Built-in I/O	4-17
4-3-5	Restrictions on Inrush Current for ON/OFF Operation.....	4-18
4-4	Selecting External Power Supplies and Protective Devices.....	4-19

4-4-1	Selecting the Unit Power Supply	4-19
4-4-2	Selecting the I/O Power Supplies	4-21
4-4-3	Selecting Protective Devices	4-22

Section 5 Installation and Wiring

5-1	Processing at Power ON and Power OFF	5-3
5-1-1	Power ON Operation	5-3
5-1-2	Power OFF Operation	5-5
5-1-3	Resetting the Controller from the Sysmac Studio	5-7
5-2	Fail-safe Circuits	5-8
5-3	Mounting Units	5-11
5-3-1	Installation in a Control Panel	5-12
5-3-2	Preparations for Installation	5-16
5-3-3	Installing the CPU Unit	5-18
5-3-4	Installing and Connecting NX Units	5-20
5-3-5	Mounting the End Cover	5-24
5-3-6	Mounting the End Plates	5-25
5-3-7	Attaching Markers	5-26
5-3-8	Installing and Removing the SD Memory Card	5-27
5-3-9	Attaching and Removing Option Boards	5-32
5-3-10	Battery Installation	5-33
5-3-11	Removing CPU Unit	5-36
5-3-12	Removing NX Units	5-37
5-3-13	Assembled Appearance and Dimensions	5-38
5-4	Wiring	5-42
5-4-1	Wiring the Unit Power Supply	5-43
5-4-2	Wiring the Additional NX Unit Power Supply Unit	5-43
5-4-3	Wiring the Additional I/O Power Supply Unit	5-43
5-4-4	Wiring the Protective Devices	5-43
5-4-5	Grounding	5-44
5-4-6	Wiring the Built-in EtherCAT Port	5-49
5-4-7	Wiring the Built-in EtherNet/IP Port	5-49
5-4-8	Wiring to the CPU Unit Terminal Block	5-49
5-4-9	Wiring the built-in I/O	5-63
5-4-10	Wiring the NX1W-CIF01 Serial Communications Option Board	5-67
5-4-11	Wiring the NX1W-CIF11/-CIF12 Serial Communications Option Board	5-72
5-4-12	Wiring the Analog I/O Option Board	5-75
5-5	Control Panel Installation	5-81
5-5-1	Temperature	5-81
5-5-2	Humidity	5-83
5-5-3	Vibration and Shock	5-83
5-5-4	Atmosphere	5-83
5-5-5	Electrical Environment	5-84
5-5-6	Grounding	5-88

Section 6 Troubleshooting

6-1	Overview of Troubleshooting	6-2
------------	--	------------

Section 7 Inspection and Maintenance

7-1	Cleaning and Maintenance	7-2
7-1-1	Cleaning	7-2
7-1-2	Periodic Inspections	7-3
7-1-3	Unit Replacement Precautions	7-4
7-2	Replacing the Battery	7-6

Appendices

A-1	Specifications	A-2
A-2	Dimensions	A-3
A-2-1	NX-series NX1P2 CPU Units	A-3
A-2-2	End Cover	A-4
A-2-3	SD Memory Card	A-4
A-2-4	Option Boards	A-5
A-3	Version Information	A-6
A-3-1	Relationship between Unit Versions of CPU Units and Sysmac Studio Versions	A-6
A-3-2	Functions That Were Added or Changed for Each Unit Version	A-7
A-4	Support Functions of the CPU Units and Restrictions on the NX Units	A-9

Index

Terms and Conditions Agreement

Warranty, Limitations of Liability

Warranties

● Exclusive Warranty

Omron's exclusive warranty is that the Products will be free from defects in materials and workmanship for a period of twelve months from the date of sale by Omron (or such other period expressed in writing by Omron). Omron disclaims all other warranties, express or implied.

● Limitations

OMRON MAKES NO WARRANTY OR REPRESENTATION, EXPRESS OR IMPLIED, ABOUT NON-INFRINGEMENT, MERCHANTABILITY OR FITNESS FOR A PARTICULAR PURPOSE OF THE PRODUCTS. BUYER ACKNOWLEDGES THAT IT ALONE HAS DETERMINED THAT THE PRODUCTS WILL SUITABLY MEET THE REQUIREMENTS OF THEIR INTENDED USE.

Omron further disclaims all warranties and responsibility of any type for claims or expenses based on infringement by the Products or otherwise of any intellectual property right.

● Buyer Remedy

Omron's sole obligation hereunder shall be, at Omron's election, to (i) replace (in the form originally shipped with Buyer responsible for labor charges for removal or replacement thereof) the non-complying Product, (ii) repair the non-complying Product, or (iii) repay or credit Buyer an amount equal to the purchase price of the non-complying Product; provided that in no event shall Omron be responsible for warranty, repair, indemnity or any other claims or expenses regarding the Products unless Omron's analysis confirms that the Products were properly handled, stored, installed and maintained and not subject to contamination, abuse, misuse or inappropriate modification. Return of any Products by Buyer must be approved in writing by Omron before shipment. Omron Companies shall not be liable for the suitability or unsuitability or the results from the use of Products in combination with any electrical or electronic components, circuits, system assemblies or any other materials or substances or environments. Any advice, recommendations or information given orally or in writing, are not to be construed as an amendment or addition to the above warranty.

See <http://www.omron.com/global/> or contact your Omron representative for published information.

Limitation on Liability; Etc

OMRON COMPANIES SHALL NOT BE LIABLE FOR SPECIAL, INDIRECT, INCIDENTAL, OR CONSEQUENTIAL DAMAGES, LOSS OF PROFITS OR PRODUCTION OR COMMERCIAL LOSS IN ANY

WAY CONNECTED WITH THE PRODUCTS, WHETHER SUCH CLAIM IS BASED IN CONTRACT, WARRANTY, NEGLIGENCE OR STRICT LIABILITY.

Further, in no event shall liability of Omron Companies exceed the individual price of the Product on which liability is asserted.

Application Considerations

Suitability of Use

Omron Companies shall not be responsible for conformity with any standards, codes or regulations which apply to the combination of the Product in the Buyer's application or use of the Product. At Buyer's request, Omron will provide applicable third party certification documents identifying ratings and limitations of use which apply to the Product. This information by itself is not sufficient for a complete determination of the suitability of the Product in combination with the end product, machine, system, or other application or use. Buyer shall be solely responsible for determining appropriateness of the particular Product with respect to Buyer's application, product or system. Buyer shall take application responsibility in all cases.

NEVER USE THE PRODUCT FOR AN APPLICATION INVOLVING SERIOUS RISK TO LIFE OR PROPERTY OR IN LARGE QUANTITIES WITHOUT ENSURING THAT THE SYSTEM AS A WHOLE HAS BEEN DESIGNED TO ADDRESS THE RISKS, AND THAT THE OMRON PRODUCT(S) IS PROPERLY RATED AND INSTALLED FOR THE INTENDED USE WITHIN THE OVERALL EQUIPMENT OR SYSTEM.

Programmable Products

Omron Companies shall not be responsible for the user's programming of a programmable Product, or any consequence thereof.

Disclaimers

Performance Data

Data presented in Omron Company websites, catalogs and other materials is provided as a guide for the user in determining suitability and does not constitute a warranty. It may represent the result of Omron's test conditions, and the user must correlate it to actual application requirements. Actual performance is subject to the Omron's Warranty and Limitations of Liability.

Change in Specifications

Product specifications and accessories may be changed at any time based on improvements and other reasons. It is our practice to change part numbers when published ratings or features are changed, or when significant construction changes are made. However, some specifications of the Product may

be changed without any notice. When in doubt, special part numbers may be assigned to fix or establish key specifications for your application. Please consult with your Omron's representative at any time to confirm actual specifications of purchased Product.

Errors and Omissions



Information presented by Omron Companies has been checked and is believed to be accurate; however, no responsibility is assumed for clerical, typographical or proofreading errors or omissions.

Safety Precautions





Definition of Precautionary Information

The following notation is used in this manual to provide precautions required to ensure safe usage of an NX-series Controller. The safety precautions that are provided are extremely important to safety. Always read and heed the information provided in all safety precautions.

The following notation is used.

 WARNING	Indicates a potentially hazardous situation which, if not avoided, could result in death or serious injury. Additionally, there may be severe property damage.
 Caution	Indicates a potentially hazardous situation which, if not avoided, may result in minor or moderate injury, or property damage.

Symbols

	The circle and slash symbol indicates operations that you must not do. The specific operation is shown in the circle and explained in text. This example indicates prohibiting disassembly.
	The triangle symbol indicates precautions (including warnings). The specific operation is shown in the triangle and explained in text. This example indicates a precaution for electric shock.
	The triangle symbol indicates precautions (including warnings). The specific operation is shown in the triangle and explained in text. This example indicates a general precaution.
	The filled circle symbol indicates operations that you must do. The specific operation is shown in the circle and explained in text. This example shows a general precaution for something that you must do.
	The triangle symbol indicates precautions (including warnings). The specific operation is shown in the triangle and explained in text. This example indicates a precaution for high temperatures.

WARNING**⚠ WARNING****During Power Supply**

Do not touch any of the terminals or terminal blocks while the power is being supplied. Doing so may result in electric shock.



Do not attempt to take any Unit apart.

In particular, high-voltage parts are present in the Power Supply Unit while power is supplied or immediately after power is turned OFF. Touching any of these parts may result in electric shock. There are sharp parts inside the Unit that may cause injury.

**Fail-safe Measures**

Provide safety measures in external circuits to ensure safety in the system if an abnormality occurs due to malfunction of the CPU Unit, slaves, or Units or due to other external factors affecting operation. Not doing so may result in serious accidents due to incorrect operation.



Emergency stop circuits, interlock circuits, limit circuits, and similar safety measures must be provided in external control circuits.



The Controller outputs may remain ON or OFF due to deposition or burning of the output relays or destruction of the output transistors. As a countermeasure for such problems, external safety measures must be provided to ensure safe operation of the system.



The CPU Unit will turn OFF digital outputs on the CPU Rack in the following cases.

- While the CPU Unit is on standby until RUN mode is entered after the power is turned ON
- If an error occurs in the power supply
- If a system initialization error occurs

Digital outputs on the CPU Rack will produce outputs according to the settings in the following cases.

- If a CPU Unit error or CPU Unit reset occurs
- If a major fault level Controller error occurs

External safety measures must be provided to ensure safe operation of the system in such cases.



If there is interference in remote I/O communications or if a major fault level error occurs, output status will depend on the products that are used.

Confirm the operation that will occur when there is interference in communications or a major fault level error, and implement safety measures.

Correctly set all of the settings in the slaves and Units.



If external power supplies for Units, slaves or other devices are overloaded or short-circuited, the voltage will drop, outputs will turn OFF, and the system may be unable to read inputs. Provide external safety measures in controls with monitoring of external power supply voltage as required so that the system operates safely in such a case.



Unintended outputs may occur when an error occurs in variable memory. As a counter-measure for such problems, external safety measures must be provided to ensure safe operation of the system.



Provide measures in the communications system and user program to ensure safety in the overall system even if errors or malfunctions occur in data link communications or remote I/O communications.



The NX-series Controller continues normal operation for a certain period of time when a momentary power interruption occurs. This means that the NX-series Controller may receive incorrect signals from external devices that are also affected by the power interruption.



Accordingly, take suitable actions, such as external fail-safe measures and interlock conditions, to monitor the power supply voltage of the external device as required.

You must take fail-safe measures to ensure safety in the event of incorrect, missing, or abnormal signals caused by broken signal lines, momentary power interruptions, or other causes.



Not doing so may result in serious accidents due to incorrect operation.

Voltage and Current Inputs

Make sure that the voltages and currents that are input to the slaves and Units are within the specified ranges.

Inputting voltages or currents that are outside of the specified ranges may cause accidents or fire.



Downloading

Always confirm safety at the destination before you transfer a user program, configuration data, setup data, or device variables from the Sysmac Studio.

The devices or machines may perform unexpected operation regardless of the operating mode of the CPU Unit.



Actual Operation

Check the user program, data, and parameter settings for proper execution before you use them for actual operation.



Cautions

⚠ Caution

Application

Do not touch any Unit when power is being supplied or immediately after the power supply is turned OFF. Doing so may result in burn injury.



Wiring

Be sure that all terminal screws and cable connector screws are tightened to the torque specified in the relevant manuals. The loose screws may result in fire or malfunction.



When you connect a computer or other peripheral device to a Controller that has a non-isolated DC power supply, either ground the 0-V side of the external power supply for the Unit power supply or do not ground it at all.

If the peripheral devices are grounded incorrectly, the external power supply for the Unit power supply may be short-circuited. Never ground the 24-V side of the power supply, as shown in the following figure.

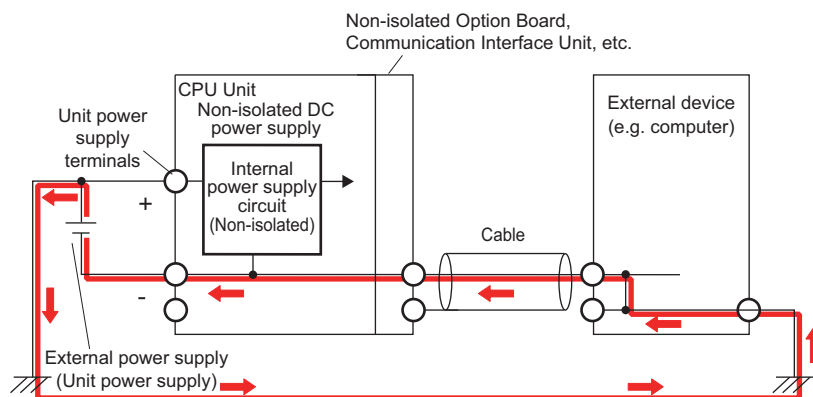

Online Editing

Execute online editing only after confirming that no adverse effects will be caused by deviations in the timing of I/O. If you perform online editing, the task execution time may exceed the task period, I/O may not be refreshed with external devices, input signals may not be read, and output timing may change.



EtherCAT Communications

If the cable redundancy function is enabled, always write a program to confirm that the network is in the cable redundancy status. If the program is not written, you cannot check that the network is not in the cable redundancy status due to a disconnection on the ring topology.

Use the `_EC_RingBreaking` system-defined variable to confirm that the network is in the cable redundancy status.



Version Information

The cable redundancy function can be used with project unit version 1.40 or later.

Precautions for Safe Use

Transporting and Disassembly

- Do not attempt to disassemble, repair, or modify any Units. Doing so may result in malfunction or fire.
- Do not drop any Unit or subject it to abnormal vibration or shock. Doing so may result in Unit malfunction or burning.
- When transporting any Unit, use the special packing box for it. Also, do not subject the Unit to excessive vibration or shock during transportation.

Mounting

- Always turn OFF the power supply before mounting the Units. If the power supply is not OFF, the Unit may result in malfunction or may be damaged.
- Do not apply labels or tape to the Unit. When the Unit is installed or removed, adhesive or scraps may adhere to the pins in the NX bus connector, which may result in malfunctions.
- Do not touch the pins in the NX bus connector on the Unit. Dirt may adhere to the pins in the NX bus connector, which may result in malfunctions.

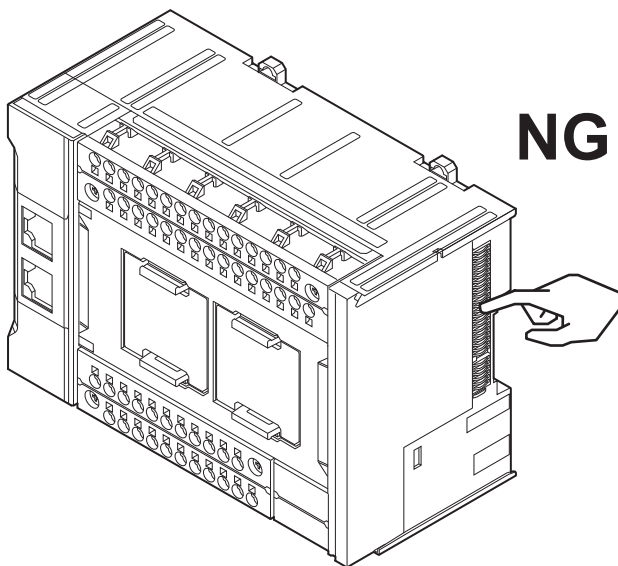

- Do not write on the CPU Unit with ink within the restricted region that is shown in the following figure. Also do not get this area dirty. When the Unit is installed or removed, ink or dirt may adhere to the pins in the NX bus connector, which may result in malfunctions in the Unit. Refer to the user's manual for the connected NX Unit for information on the restricted region for the NX Unit.

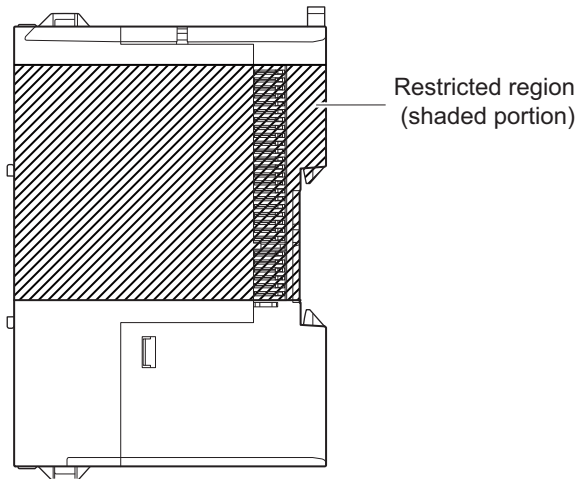

- The End Cover has a metal portion and is heavier than it looks. Be careful not to drop it when handling.

Installation

- Always connect to a ground of 100 Ω or less when installing the Units.

Wiring

- Follow the instructions in this manual to correctly perform wiring.
Double-check all wiring and switch settings before turning ON the power supply.
- Use the methods that are specified in this manual for wiring the terminal blocks.
- Use crimp terminals for wiring the M3 screw terminal blocks. Do not connect bare stranded wires directly to the M3 screw terminal blocks.
- Use the correct wiring parts and tools when you wire the system. Otherwise, cables may be disconnected to cause short-circuit or wire breakage.
- Do not pull on the cables or bend the cables beyond their natural limit.
Do not place heavy objects on top of the cables or other wiring lines. Doing so may break the cables.
- Mount terminal blocks, connectors, and Option Boards only after checking the mounting location carefully.
- Be sure that the terminal blocks, communications cables, and Option Boards with tightening screws or locking devices are properly tightened to or locked into place.
- If the external power supply to a built-in output, Output Unit or slave has polarity, connect it with the correct polarity. If the polarity is reversed, current may flow in the reverse direction and damage the connected devices regardless of the operation of the Controller.
- When you insert a flat-blade screwdriver into a release hole on a screwless clamping terminal block of CPU Unit, press it down with a force of 30N or less. Applying excessive force may damage the terminal block.
- Do not incline or twist the flat-blade screwdriver while it is in a release hole on a screwless clamping terminal block of CPU Unit. Doing so may damage the terminal block.

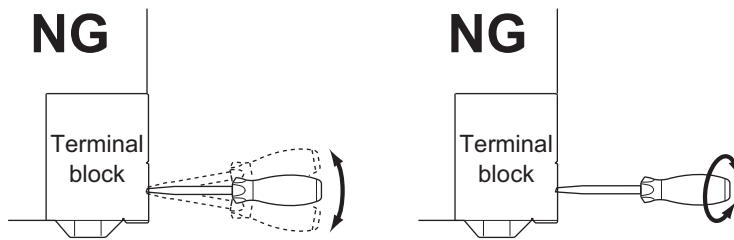

- The angle at which you insert a screwdriver in the release holes on the screwless clamping terminal blocks of the CPU Unit is different from that on the screwless clamping terminal blocks of NX Units. Check the wiring method for the NX Unit and perform wiring correctly. Refer to the user's manual of the specific NX Unit for how to wire an NX Unit.

Power Supply Design

- Select an external power supply with sufficient capacity by considering the power supply capacity or inrush current when the power is turned ON that is specified in this manual. Otherwise, the external power supply may not be turned ON or malfunction due to unstable power supply voltage.
- Use the I/O power supply current for the CPU Rack of NX1P2 CPU Unit at 4 A or less. Using the currents that are outside of the specifications may cause failure or damage.
- Use all Units within the I/O power supply ranges that are given in the specifications.
- Do not apply voltages that exceed the rated value to any Input Unit, slave, or input built in the CPU Unit.
- Do not apply voltages or connect loads to the Output Units, slaves, or CPU Unit's internal outputs in excess of the ratings.
- Surge current occurs when the power supply is turned ON. When selecting fuses or breakers for external circuits, consider the above precaution and allow sufficient margin in shut-off performance. Refer to this manual for surge current specifications.
- If the full dielectric strength voltage is applied or turned OFF using the switch on the tester, the generated impulse voltage may damage the Power Supply Unit. Use the adjustment on the tester to gradually increase and decrease the voltage.
- Install external breakers and take other safety measures against short-circuiting and overcurrents in external wiring.
- Do not apply voltages or connect loads in excess of the maximum switching capacity.

Turning ON the Power Supply

- It takes approximately 20 seconds to enter RUN mode after the power supply is turned ON. During that time, digital outputs on the CPU Rack will be OFF. The slave outputs behave according to the setting values.
Use the system-defined variables and the NX Unit device variables in the user program to confirm that I/O data communications are established before attempting control operations. External communications are also not performed during startup.
- Configure the external circuits so that the power supply to the control system turns ON only after the power supply to the Controller has turned ON. If the power supply to the Controller is turned ON after the control power supply, temporary errors may result in incorrect control system signals

because the output terminals on Output Units may momentarily turn ON when power supply is turned ON to the Controller.

- If you transfer data from a backup file on an SD Memory Card to the Controller when the power supply is turned ON, properly select the data groups to transfer. If the data for an unintended data group is transferred to the Controller, it may cause the equipment to operate unpredictably.
- You cannot obtain normal input data from NX Units while the Units are restarting. Use the system-defined variables or device variables for the NX Units on the CPU Unit in the user program to check the validity of the I/O data before you attempt control operations.

Actual Operation

- If you change the fail-soft operation setting, the output status when the error occurs may also change. Confirm safety before you change the setting.
- If you use fail-soft operation, write programming to determine whether Unit I/O data is valid. Without such programming, the user program cannot distinguish between Units for which I/O refreshing is continued and Units for which I/O refreshing is stopped.

Turning OFF the Power Supply

- Never turn OFF the power supply to the Controller when the BUSY indicator is flashing. While the BUSY indicator is lit, the user program and settings in the CPU Unit are being backed up in the built-in non-volatile memory. This data will not be backed up correctly if the power supply is turned OFF. Also, a major fault level Controller error will occur the next time you start operation, and operation will stop.
- Do not turn OFF the power supply or remove the SD Memory Card while SD Memory Card access is in progress (i.e., while the SD BUSY indicator flashes). Data may become corrupted, and the Controller will not operate correctly if it uses corrupted data. To remove the SD Memory Card from the CPU Unit while the power supply is ON, press the SD Memory Card power supply switch and wait for the SD BUSY indicator and SD PWR indicator to turn OFF before you remove the SD Memory Card.
- Do not disconnect the cable or turn OFF the power supply to the Controller when downloading data or the user program from Support Software.
- Always turn OFF the power supply to the Controller before you attempt any of the following.
 - a) Mounting or removing the Units
 - b) Assembling the Units
 - c) Setting DIP switches or rotary switches
 - d) Connecting cables or wiring the system
 - e) Connecting or disconnecting the terminal blocks or connectors
 - f) Mounting or removing the Option Boards

The Power Supply Unit may continue to supply power to the rest of the Controller for a few seconds after the power supply turns OFF. The POWER indicator is lit during this time. Confirm that the POWER indicator is not lit before you perform any of the above.

Operation

- Confirm that no adverse effect will occur in the system before you attempt any of the following.

- a) Changing the operating mode of the CPU Unit (including changing the setting of the Startup Mode)
 - b) Changing the user program or settings
 - c) Changing set values or present values
 - d) Forced refreshing
 - e) Starting the CPU Unit with the battery exhausted
 - f) Restarting a slave or Unit after you change any settings
 - g) Transferring a backup file on the SD Memory Card
- After you change any slave or Unit settings, carefully check the safety of the controlled system before you restart the Unit.
 - If two different function modules are used together, such as when you use EtherNet/IP and EtherCAT slaves, take suitable measures in the user program and external controls to ensure that safety is maintained in the controlled system if one of the function modules stops. The relevant outputs will behave according to the slave or Unit specifications if a partial fault level error occurs in one of the function modules.
 - Always confirm safety at the connected equipment before you reset Controller errors with an event level of partial fault or higher for the EtherCAT Master Function Module.
When the error is reset, all slaves that were in any state other than Operational state due to a Controller error with an event level of partial fault or higher (in which outputs are disabled) will go to Operational state and the outputs will be enabled.
Before you reset all errors or restart a slave, confirm that no Controller errors with an event level of partial fault have occurred for the EtherCAT Master Function Module.

Battery Backup

- If you use the clock data in the user program and turn OFF the power supply for a long time, use a Battery which is sold separately.
The Battery is not mounted when the product is at factory setting. The clock data is retained by the built-in capacitor. The capacitor is charged while the power is supplied and discharged while the power is not supplied. If the power OFF time rate is high, the clock data is initialized and malfunctions may occur in the program for which the clock data is used.
- If you use the Battery, connect the Sysmac Studio and set the **Battery-related error detection to Use**. The **Battery-related error detection** is set to **Do not use** at the factory setting because the Battery is not built in. If the Battery-related error detection is set to **Do not use**, an error cannot be detected when the Battery is exhausted and malfunctions may occur in the program for which the clock data is used.

Debugging

- Forced refreshing ignores the results of user program execution and refreshes I/O with the specified values. If forced refreshing is used for inputs for which I/O refreshing is not supported, the inputs will first take the specified values, but they will then be overwritten by the user program. Be careful that this operation differs from the force-set/reset functionality of the CJ/CP-series PLCs.
- You cannot upload or download information for forced refreshing with the Sysmac Studio.
After downloading data that contains forced refreshing, change to RUN mode and then use the Sysmac Studio to perform the operation for forced refreshing.

Depending on the difference in the forced status, the control system may operate unexpectedly.

- Do not specify the same address for the AT specification for more than one variable.

Doing so would allow the same entity to be accessed with different variable names, which would make the user program more difficult to understand and possibly cause programming mistakes.

General Communications

- When you use data link communications, check the error information that is given in `_ErrSta` (Controller Error Status) to make sure that no error has occurred in the source device. Create a user program that uses reception data only when there is no error in the source device.

If there is an error in the source device, the data for the data link may contain incorrect values.

- Unexpected operation may result if inappropriate data link tables are set. Even if appropriate data link tables have been set, confirm that the controlled system will not be adversely affected before you transfer the data link tables. The data links start automatically after the data link tables are transferred.

EtherNet/IP Communications

- Make sure to use the communications distance, number of nodes connected, and method of connection for EtherNet/IP within specifications. Do not connect EtherNet/IP communications to EtherCAT or other networks. An overload may cause the network to fail or malfunction.
- All related EtherNet/IP nodes are reset when you transfer settings for the built-in EtherNet/IP port (including IP addresses and tag data links settings). The settings can only be enabled after the reset. Confirm that the system will not be adversely affected by resetting nodes before you transfer the settings.
- If EtherNet/IP tag data links (cyclic communications) are used with a repeating hub, the communications load on the network will increase. This will increase collisions and may prevent stable communications. Do not use repeating hubs on networks where tag data links are used. Use an Ethernet switch instead.

EtherCAT Communications

- Make sure to use the communications distance, number of nodes connected, and method of connection for EtherCAT within specifications.
Do not connect EtherCAT communications to EtherNet/IP, a standard in-house LAN, or other networks. An overload may cause the network to fail or malfunction.
- Malfunctions or unexpected operation may occur for some combinations of EtherCAT revisions of the master and slaves. If you disable the revision check in the network settings, use the Sysmac Studio to check the slave revision settings in the master and the actual slave revisions, and then make sure that functionality is compatible in the slave manuals or other references. You can check the actual slave revisions from the Sysmac Studio or on slave nameplates.
- After you transfer the user program, the CPU Unit is restarted and communications with the EtherCAT slaves are cut off. During that period, the slave outputs behave according to the slave specifications. The time that communications are cut off depends on the EtherCAT network configuration. Before you transfer the user program, confirm that the system will not be adversely affected.

- If the **Fail-soft Operation Setting** is set to *Stop*, process data communications will stop for all slaves when an EtherCAT communications error is detected in a slave. At that time, the Servo Drive will operate according to the Servo Drive specifications. Make sure that the *Fail-soft Operation setting* results in safe operation when a device error occurs.
- EtherCAT communications are not always established immediately after the power supply is turned ON. Use the system-defined variables in the user program to confirm that communications are established before attempting control operations.
- If noise occurs or an EtherCAT slave is disconnected from the network, any current communications frames may be lost. If frames are lost, slave I/O data is not communicated, and unintended operation may occur. The slave outputs will behave according to the slave specifications. Refer to the manual for the slave. If a noise countermeasure or slave replacement is required, perform the following processing.
 - a) Program the Input Data Invalid system-defined variable as an interlock condition in the user program.
 - b) Set the **PDO communications timeout detection count** setting in the EtherCAT master to at least 2. Refer to the *NJ/NX-series CPU Unit Built-in EtherCAT Port User's Manual* (Cat. No. W505) for details.
- When an EtherCAT slave is disconnected, communications will stop and control of the outputs will be lost not only for the disconnected slave, but for all slaves connected after it through to the physical end node. Confirm that the system will not be adversely affected before you disconnect a slave.
- I/O data communications of NX bus are not always established immediately after the power supply is turned ON. Use the system-defined variables and the EtherCAT Coupler Unit device variables in the user program to confirm that I/O data communications are established before attempting control operations.
- You cannot use standard Ethernet hubs or repeater hubs with EtherCAT communications. If you use one of these, a major fault level error or other error may occur.
- Confirm that all of the slaves are connected before you set the transmission delay time by the actual measurement. If the transmission delay time is exceeded from the set values due to the changes of the unit configuration, such as when the disabled slave is connected to the actual configuration after the setting, it may cause illegal communications with slaves.
- If you use the cable redundancy function while slaves from other manufacturers are connected on the ring topology, disconnect and connect communications cables that are connected to the slaves from other manufacturers on the ring topology or turn OFF and ON the power supply to the slaves from other manufacturers. Use the *Frame reception timeout count* in the Master Diagnosis/Statistics Information to confirm that frames are not lost consecutively.
- If you use the cable redundancy function, confirm that the task execution time is within the task period while the cable for the end port of the ring is disconnected. When a disconnection occurred on the ring topology, the transmission delay time is increased and the task execution time may be longer.



Version Information

The cable redundancy function can be used with project unit version 1.40 or later.

Motion control

- Confirm the axis number carefully before you perform an MC Test Run.

- The motor is stopped if communications are interrupted between the Sysmac Studio and the CPU Unit during an MC Test Run. Connect the communications cable between the computer and CPU Unit securely and confirm that the system will not be adversely affected before you perform an MC Test Run.
- Always execute the Save Cam Table instruction if you change any of the cam data from the user program in the CPU Unit or from the Sysmac Studio. If the cam data is not saved, the previous condition will be restored when the power is turned ON again, possibly causing unexpected machine operation.
- The positive drive prohibit input (POT), negative drive prohibit input (NOT), and home proximity input (DEC) of the Servo Drive are used by the MC Function Module as the positive limit input, negative limit input, and home proximity input. Make sure that the signal widths for all of these input signals are longer than the control period of the MC Function Module. If the input signal widths are shorter than the control period, the MC Function Module may not be able to detect the input signals, resulting in incorrect operation.
- If you make any changes in the Detailed Settings Area of the **Axis Basic Settings** Display of the Sysmac Studio, make sure that the devices or machines perform the expected operation before you start actual operation.

If the relationship between the functions of the Motion Control Function Module and the EtherCAT slave process data that is assigned to the axes is not correct, the devices or machines may perform unexpected operation.

- Always use the axis at a constant velocity for the MC_DigitalCamSwitch (Enable Digital Cam Switch) instruction.

If you set the Count Mode to Rotary Mode, the following operation will occur if you use OnCompensation or OffCompensation and the axis velocity changes abruptly.

- If the value of OnCompensation or OffCompensation is equivalent to the time for half a rotation or more, InOperation will be FALSE.
- If the value of OnCompensation results in exceeding LastOnPosition, the output timing will be unstable.

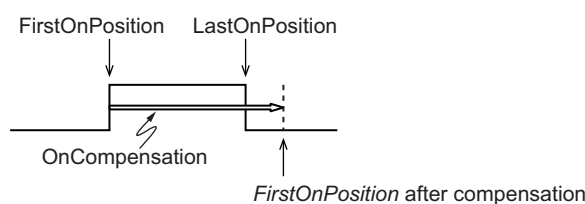

- If the value of OffCompensation results in exceeding FirstOnPosition, the output timing will be unstable.

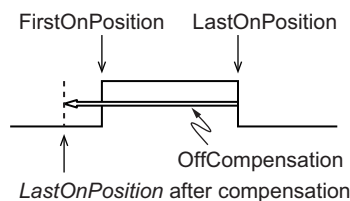

- Use the NX_AryDOutTimeStamp (Write Digital Output Array with Specified Time Stamp) instruction only after you confirm that InOperation from the MC_DigitalCamSwitch (Enable Digital Cam Switch) instruction is TRUE.

- If you change the unit conversion settings, perform homing again. If you do not perform homing, unintended operation of the controlled system may occur.

Restoring Data

- You cannot back up, restore, or compare some or all of the settings for certain slaves and Units. Also, you cannot back up, restore, or compare data for disabled slaves or Units. After you restore data, sufficiently confirm that operation is correct before you start actual operation.
- If any of the following conditions is met, clear the absolute encoder home offsets from the list of data items to restore, and then restore the data. Then, define the absolute encoder home again. If you do not define home, unintended operation of the controlled system may occur.
 - a) The Servomotor or Servo Drive was changed since the data was backed up.
 - b) The absolute encoder was set up after the data was backed up.
 - c) The absolute data for the absolute encoder was lost.

Transferring Programs

- When you use the program transfer from SD Memory Card whose Startup Mode setting is set to RUN mode, the operating mode changes to RUN after the transfer is completed regardless of the status and setting before the transfer. Use this function after you confirm that system startup does not cause any problem.
- Always confirm safety at the connected equipment before you perform the following operations when the device output hold configuration is set to enable. The equipment may operate unexpectedly because the last status for outputs is retained.
 - a) Changing the operating mode of the CPU Unit
 - b) When downloaded
- When you transfer the values retained in the memory of the CJ-series Units, always check the set values of the Device Output Hold Configuration and make sure that the destination is safe. The devices or machines may perform unexpected operation regardless of the operating mode of the CPU Unit.

Battery Installation and Replacement

- The Battery may leak, rupture, heat, or ignite. Never short-circuit, charge, disassemble, heat, or incinerate the Battery or subject it to strong shock.
- Dispose of any Battery that has been dropped on the floor or otherwise subjected to excessive shock. Batteries that have been subjected to shock may leak if they are used.
- Apply power for at least five minutes before changing the Battery. Install a new Battery within five minutes (at 25°C) of turning OFF the power supply. If power is not supplied for at least 5 minutes, the retained clock data may be initialized.
- We recommend mounting or replacing the Battery with the power turned OFF to prevent the CPU Unit's sensitive internal components from being damaged by static electricity and to prevent malfunctions. The Battery can be mounted or replaced without turning OFF the power supply. To do so, always touch a grounded piece of metal to discharge static electricity from your body before you start the procedure.

If the Low Battery Voltage error occurs after you mount the Battery, connect the Sysmac Studio and clear the error.

Unit Replacement

- Make sure that the required data, including the user program, configurations, settings, and variables, is transferred to a CPU Unit that was replaced and to externally connected devices before re-starting operation. Be sure to include the tag data link settings and routing tables, which are stored in the CPU Unit.
- The absolute encoder home offsets are retained in the CPU Unit as absolute encoder information. When you change the combination of the CPU Unit and Servomotor, e.g., when you add or replace a Servomotor, define the absolute encoder home again.
- Always turn OFF the Unit power supply and I/O power supply before you remove the NX Unit.

Disposal

- Dispose of the Units and Batteries according to local ordinances as they apply.



廢電池請回收

- The following information must be displayed for all products that contain primary lithium batteries with a perchlorate content of 6 ppb or higher when shipped to or transported through the State of California, USA.
Perchlorate Material - special handling may apply.
See www.dtsc.ca.gov/hazardouswaste/perchlorate.
- The Battery is a primary lithium battery with a perchlorate content of 6 ppb or higher. Place the above information on the individual boxes and shipping boxes when shipping finished products that contain a CPU Unit with a mounted Battery to the State of California, USA.

Backup

- We recommend that you back up the present values of variables while the retained variables are not refreshed.
If you back up while the values of retained variables are refreshed, the data may not be saved correctly.
For information on Backup Functions and a backup for present values of variables, refer to the *NJ/NX-series CPU Unit Software User's Manual (Cat. No. W501)*.

Designing Tasks

- If the following variables are specified for a condition expression when the execution condition is a condition expression for a variable, event tasks may not be executed when conditions are met or event tasks may be executed when conditions are not met.
 - a) Structure members whose data size is 16 bits or more, except for system-defined variables for motion control

b) Array elements whose data size is 16 bits or more

For information on event task execution conditions, refer to the *NJ/NX-series CPU Unit Software User's Manual (Cat. No. W501)*.

Precautions for Correct Use

Storage and Installation

- Follow the instructions in this manual to correctly perform installation.
- Do not operate or store the Controller in the following locations. Doing so may result in burning, in operation stopping, or in malfunction.
 - a) Locations subject to direct sunlight
 - b) Locations subject to temperatures or humidity outside the range specified in the specifications
 - c) Locations subject to condensation as the result of severe changes in temperature
 - d) Locations subject to corrosive or flammable gases
 - e) Locations subject to dust (especially iron dust) or salts
 - f) Locations subject to exposure to water, oil, or chemicals
 - g) Locations subject to shock or vibration
- Take appropriate and sufficient countermeasures when installing the Controller in the following locations.
 - a) Locations subject to strong, high-frequency noise
 - b) Locations subject to static electricity or other forms of noise
 - c) Locations subject to strong electromagnetic fields
 - d) Locations subject to possible exposure to radioactivity
 - e) Locations close to power lines
- Before touching a Unit, be sure to first touch a grounded metallic object in order to discharge any static build-up.
- Install the Controller away from sources of heat and ensure proper ventilation. Not doing so may result in malfunction, in operation stopping, or in burning.

Mounting

- When you install the Unit, be careful not to touch or bump the pins in the NX bus connector.
- When you handle the Unit, be careful not to apply stress to the pins in the NX bus connector. If the Unit is installed and the power supply is turned ON when the pins in the NX bus connector are deformed, contact failure may cause malfunctions.
- Always mount an End Cover to the end of the CPU Rack to protect the last Unit on the CPU Rack. Not mounting the End Cover may result in malfunction or failure of the CPU Unit.
- After you mount the Unit, always secure it with End Plates at both sides. If you do not secure it, the Unit may be damaged or malfunction.
- If you use DIN Track Insulation Spacers to install a CPU Rack, the height will be increased by approximately 10 mm. Make sure that the CPU Rack and connecting cables do not come into contact with other devices.

Wiring

- Do not allow foreign matter to enter the openings in the Unit. Doing so may result in Unit burning, electric shock, or failure.

- Do not allow wire clippings, shavings, or other foreign material to enter any Unit. Otherwise, Unit burning, failure, or malfunction may occur. Cover the Units or take other suitable countermeasures, especially during wiring work.
- For EtherCAT and EtherNet/IP, use the connection methods and cables that are specified in the *NJ/NX-series CPU Unit Built-in EtherCAT Port User's Manual* (Cat. No. W505) and the *NJ/NX-series CPU Unit Built-in EtherNet/IP Port User's Manual* (Cat. No. W506). Otherwise, communications may be faulty.
- Use the rated power supply voltage for the Units that supply power. Take appropriate measures to ensure that the specified power with the rated voltage and frequency is supplied in places where the power supply is unstable.
- Make sure that the current capacity of the wire is sufficient. Otherwise, excessive heat may be generated. When cross-wiring terminals, the total current for all the terminals will flow in the wire. When wiring cross-overs, make sure that the current capacity of each of the wires is not exceeded.
- If you use reed switches for the input contacts for AC Input Units, use switches with a current capacity of 1 A or greater.
If reed switches with smaller allowable currents are used, the contacts may fuse due to surge currents.

Operation

- Confirm the device output hold configuration before you change the operating mode of the CPU Unit or execute the download.
- Take safety measures for the controlled system as well.

Error Processing

- In applications that use the results of instructions that read the error status, consider the affect on the system when errors are detected and program error processing accordingly. For example, even the detection of a minor error, such as Battery replacement during operation, can affect the system depending on how the user program is written.
- If you change the event level of a Controller error, the output status when the error occurs may also change. Confirm safety before use.

Restoring and Automatically Transferring Data

- When you edit the restore command file or the automatic transfer command file, do not change anything in the file except for the “yes” and “no” specifications for the selectable data groups. If you change anything else in the file, the Controller may perform unexpected operation when you restore or automatically transfer the data.
- To prevent an unexpected restoration, set to enter the password for each execution before the restore operation.

Transferring Programs

- If you use the program transfer from SD Memory Card, set to enter the password for each execution to prevent an unexpected program transfer.

Replacing Slaves and Units

- If you replace a slave or Unit, refer to the operation manual for the slave or Unit for information on the data required for individual slaves or Units and redo the necessary settings.

Task Settings

- If a Task Period Exceeded error occurs, shorten the programs to fit in the task period or increase the setting of the task period.

Motion control

- Use the system-defined variable in the user program to confirm that EtherCAT communications are established before you attempt to execute motion control instructions. Motion control instructions are not executed normally if EtherCAT communications are not established.
- Use the system-defined variables to monitor for errors in communications with the slaves that are controlled by the motion control function module. Motion control instructions are not executed normally if an error occur in slave communications.
- Before you start an MC Test Run, make sure that the operation parameters are set correctly.
- Do not download motion control settings during an MC Test Run.

EtherCAT Communications

- If you need to disconnect the cable from an EtherCAT slave during operation, first disconnect the software connection to the EtherCAT slave or disable the EtherCAT slave and all of the EtherCAT slaves that are connected after it.
- Set the Servo Drives to stop operation if an error occurs in EtherCAT communications between the Controller and a Servo Drive.
- Make sure that all of the slaves to be restored are participating in the network before you reset a Network Configuration Verification Error, Network Configuration Verification Error (Mismatched Slave), Network Configuration Verification Error (Slave Unconnected), Network Configuration Verification Error (Unnecessary Slave Connected), Network Configuration Verification Error (Incorrect Ring Wiring), Process Data Communications Error, Illegal Slave Disconnection Detected or Link OFF Error in the EtherCAT Master Function Module. If any slave is not participating when any of these errors is reset, the EtherCAT Master Function Module may access slave with a different node address than the specified node address or the error may not be reset correctly.
- Always use the specified EtherCAT slave cables. If you use any other cable, the EtherCAT master or the EtherCAT slaves may detect an error and one of the following may occur.
 - a) Continuous refreshing of process data communications will not be possible.
 - b) Continuous refreshing of process data communications will not end during the set cycle.

Battery Replacement

- Be sure to mount a Battery within two years of the production date shown on the Battery label.
- Turn ON the power after replacing the Battery for a CPU Unit that has been unused for a long time. Leaving the CPU Unit unused again without turning ON the power even once after the Battery is replaced may result in a shorter Battery life.
- If you use the Battery, use the CJ1W-BAT01 Battery Set which is sold separately.

SD Memory Cards

- Insert the SD Memory Card all the way.
- Do not turn OFF the power supply to the Controller during SD Memory Card access. The files may be corrupted.
If there is a corrupted file in the SD Memory Card, the file is automatically deleted by the restoration function when the power supply is turned ON.
- If you use an OMRON SD Memory Card, the end of the life of the SD Memory Card can be detected in the following ways.
 - a) `_Card1Deteriorated` (SD Memory Card Life Warning Flag) system-defined variable
 - b) SD Memory Card Life Exceeded event in the event logWhen the end of the life is detected in any of the above ways, replace the SD Memory Card.

Online Editing

- When performing online editing, the CPU Unit saves a program updated by the online editing to built-in non-volatile memory. Sysmac Studio shows a message that it is in a backup operation. Do not turn OFF the power supply to the Controller while this message is displayed. If the power supply to the Controller is turned OFF, a Controller error will occur when the power supply is turned ON next time.

Debugging

- If you use data tracing to sample following variables, correct data may not be sampled.
 - a) Structure members whose data size is 16 bits or more, except for system-defined variables for motion control
 - b) Array elements whose data size is 16 bits or more
- For information on data tracing, refer to the *NJ/NX-series CPU Unit Software User's Manual (Cat. No. W501)*.

Regulations and Standards

Conformance to EU Directives

Applicable Directives

- EMC Directives
- Low Voltage Directive

Concepts

● EMC Directives

OMRON devices that comply with EU Directives also conform to the related EMC standards so that they can be more easily built into other devices or the overall machine. The actual products have been checked for conformity to EMC standards.*1

Whether the products conform to the standards in the system used by the customer, however, must be checked by the customer. EMC-related performance of the OMRON devices that comply with EU Directives will vary depending on the configuration, wiring, and other conditions of the equipment or control panel on which the OMRON devices are installed. The customer must, therefore, perform the final check to confirm that devices and the overall machine conform to EMC standards.

*1. Applicable EMC (Electromagnetic Compatibility) standards are as follows: EMS (Electromagnetic Susceptibility): EN 61131-2 EMI (Electromagnetic Interference): EN 61131-2 (Radiated emission: 10-m regulations).

● Low Voltage Directive

Always ensure that devices operating at voltages of 50 to 1,000 VAC and 75 to 1,500 VDC meet the required safety standards. The applicable directive is EN 61010-2-201.

● Conformance to EU Directives

The NX-series Units comply with EU Directives. To ensure that the machine or device in which the NX-series Units are used complies with EU Directives, the following precautions must be observed.

- The NX-series Units must be installed within a control panel.
- You must use SELV power supply for the DC power supplies that are connected as the Unit power supplies and I/O power supplies for the NX-series Units. EMC standard compliance was confirmed for the OMRON S8VK-S Series DC Power Supplies.
- NX-series Units that comply with EU Directives also conform to the Common Emission Standard. Radiated emission characteristics (10-m regulations) may vary depending on the configuration of the control panel used, other devices connected to the control panel, wiring, and other conditions.

You must therefore confirm that the overall machine or equipment in which the NX-series Units are used complies with EU Directives.

- This is a Class A product (for industrial environments). In a residential environment, it may cause radio interference. If radio interference occurs, the user may be required to take appropriate measures.

Conformance to UL and CSA Standards

Some NX-series products comply with UL and CSA standards.

If you use a product that complies with UL or CSA standards and must apply those standards to your machinery or devices, refer to the *Instruction Sheet* that is provided with the product. The *Instruction Sheet* provides the application conditions for complying with the standards.

Conformance to KC Certification

When you use this product in South Korea, observe the following precautions.

사용자 안내문
이 기기는 업무용 환경에서 사용할 목적으로 적합성평가를 받은 기기로서 가정용 환경에서 사용하는 경우 전파간섭의 우려가 있습니다.

This product meets the electromagnetic compatibility requirements for business use. There is a risk of radio interference when this product is used in home.

Usage Conditions for KC Certification

Take the same measures as those described in *Conformance to EU Directives* on page 35. In addition, attach a clamp core to the port side of the EtherNet/IP cable.

The recommended clamp core is given below.

Recommended Clamp Core

Manufacturer	Product	Model	Turns of cable
NEC TOKIN	Clamp core	ESD-SR-250	1 turn

Conformance to Shipbuilding Standards

This product complies with the following shipbuilding standards. Applicability to the shipbuilding standards is based on certain usage conditions. It may not be possible to use the product in some locations. Contact your OMRON representative before attempting to use a Controller on a ship.

Usage Conditions for NK and LR Shipbuilding Standards

- This product must be installed within a control panel.
- Gaps in the door to the control panel must be completely filled or covered with gaskets or other material.
- The following noise filter must be connected to the power supply line.

Noise Filter

Manufacturer	Model
Cosel Co., Ltd.	TAH-06-683

Software Licenses and Copyrights

This product incorporates certain third party software. The license and copyright information associated with this software is available at http://www.fa.omron.co.jp/nj_info_e/.

Versions

Hardware revisions and unit versions are used to manage the hardware and software in NX-series Units and EtherCAT slaves.

The hardware revision or unit version is updated each time there is a change in hardware or software specifications. Even when two Units or EtherCAT slaves have the same model number, they will have functional or performance differences if they have different hardware revisions or unit versions.

Checking Versions

You can check versions in the ID information indications on the product or with the Sysmac Studio.

Checking Unit Versions on ID Information Indications

The unit version is given on the ID information indication on the side of the product. The ID information on an NX-series NX1P2-□□□□□□ CPU Unit is shown below.

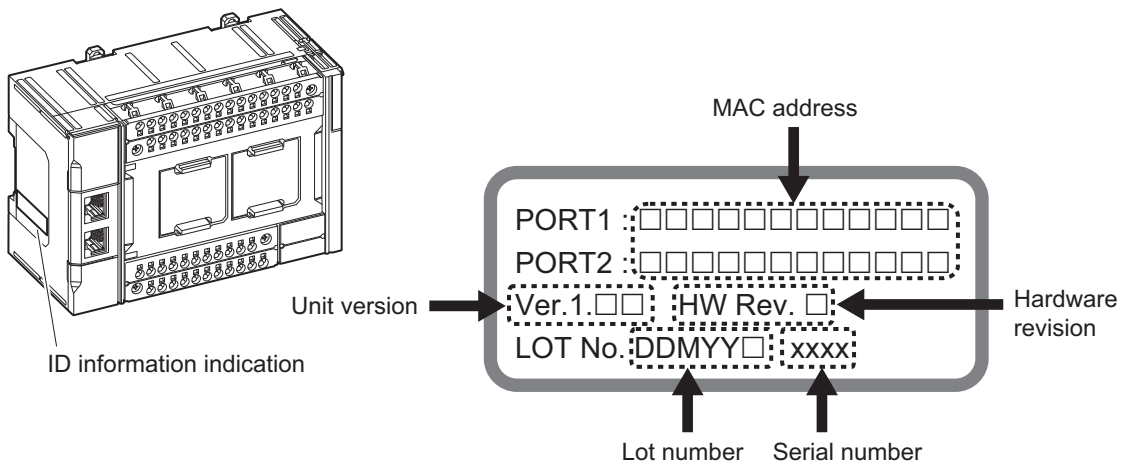

Note The hardware revision is not displayed for the Unit that the hardware revision is in blank.

Checking Unit Versions with the Sysmac Studio

● Checking the Unit Version of a Unit

You can use the **Production Information** while the Sysmac Studio is online to check the unit version of a Unit. You can do this for the CPU Unit, NX Units on the CPU Rack, and Option Boards. Use the following procedure to check the unit version.

- 1 Right-click **CPU Rack** under **Configurations and Setup - CPU/Expansion Racks** in the Multi-view Explorer and select **Display Production Information**.
The **Production Information** Dialog Box is displayed.
- 2 Click the **Show Detail** or **Show Outline** Button at the lower right of the **Production Information** Dialog Box.
The view will change between the **Production information** details and outline.

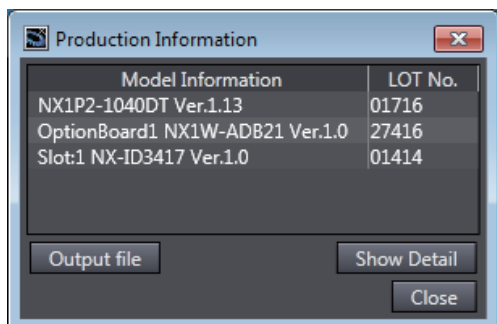

Outline View

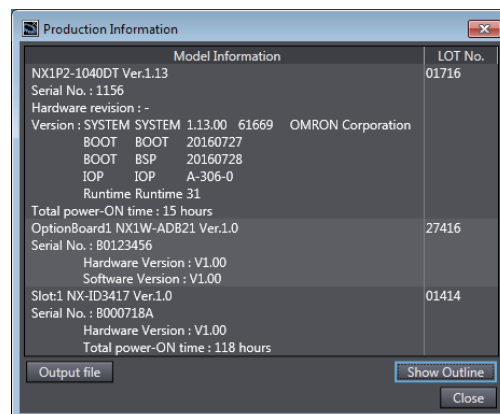

Detail View

The information that is displayed is different for the Outline View and Detail View. The Detail View displays the unit version, hardware version, and software versions. The Outline View displays only the unit version.

Note The hardware revision is separated by "/" and displayed on the right of the hardware version. The hardware revision is not displayed for the Unit that the hardware revision is in blank.

● Checking the Unit Version of an EtherCAT Slave

You can use the **Production Information** while the Sysmac Studio is online to check the unit version of an EtherCAT slave. Use the following procedure to check the unit version.

- 1 Double-click **EtherCAT** under **Configurations and Setup** in the Multiview Explorer. Or, right-click **EtherCAT** under **Configurations and Setup** and select **Edit** from the menu.
The EtherCAT Tab Page is displayed for the Controller Configurations and Setup Layer.
- 2 Right-click the master on the EtherCAT Tab Page and select **Display Production Information**.
The Production Information Dialog Box is displayed. The unit version is displayed after "Rev."

● Changing Information Displayed in Production Information Dialog Box

- 1 Click the **Show Detail** or **Show Outline** Button at the lower right of the **Production Information** Dialog Box.

The view will change between the **Production information** details and outline.

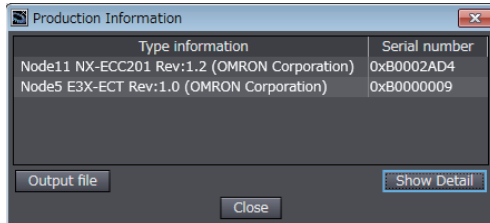

Outline View

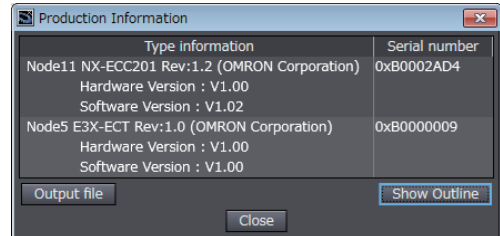

Detail View

Unit Versions of CPU Units and Sysmac Studio Versions

The functions that are supported depend on the unit version of the NX-series CPU Unit. The version of Sysmac Studio that supports the functions that were added for an upgrade is also required to use those functions.

Refer to *A-3 Version Information* on page A-6 for the relationship between the unit versions of the CPU Units and the Sysmac Studio versions, and for the functions that are supported by each unit version.

Related Manuals

The following manuals are related. Use these manuals for reference.

Manual name	Cat. No.	Model numbers	Application	Description
NX-series NX1P2 CPU Unit Hardware User's Manual	W578	NX1P2-□□□□	Learning the basic specifications of the NX1P2 CPU Units, including introductory information, designing, installation, and maintenance. Mainly hardware information is provided.	An introduction to the entire NX1P2 system is provided along with the following information on the CPU Unit. <ul style="list-style-type: none"> • Features and system configuration • Introduction • Part names and functions • General specifications • Installation and wiring • Maintenance and inspection
NX-series NX1P2 CPU Unit Built-in I/O and Option Board User's Manual	W579	NX1P2-□□□□	Learning about the details of functions only for an NX-series NX1P2 CPU Unit and an introduction of functions for an NJ/NX-series CPU Unit.	Of the functions for an NX1P2 CPU Unit, the following information is provided. <ul style="list-style-type: none"> • Built-in I/O • Serial Communications Option Boards • Analog I/O Option Boards An introduction of following functions for an NJ/NX-series CPU Unit is also provided. <ul style="list-style-type: none"> • Motion control functions • EtherNet/IP communications functions • EtherCAT communications functions
NJ/NX-series CPU Unit Software User's Manual	W501	NX701-□□□□ NX102-□□□□ NX1P2-□□□□ NJ501-□□□□ NJ301-□□□□ NJ101-□□□□	Learning how to program and set up an NJ/NX-series CPU Unit. Mainly software information is provided.	The following information is provided on a Controller built with an NJ/NX-series CPU Unit. <ul style="list-style-type: none"> • CPU Unit operation • CPU Unit features • Initial settings • Programming based on IEC 61131-3 language specifications
NJ/NX-series Instructions Reference Manual	W502	NX701-□□□□ NX102-□□□□ NX1P2-□□□□ NJ501-□□□□ NJ301-□□□□ NJ101-□□□□	Learning detailed specifications on the basic instructions of an NJ/NX-series CPU Unit.	The instructions in the instruction set (IEC 61131-3 specifications) are described.
NJ/NX-series CPU Unit Motion Control User's Manual	W507	NX701-□□□□ NX102-□□□□ NX1P2-□□□□ NJ501-□□□□ NJ301-□□□□ NJ101-□□□□	Learning about motion control settings and programming concepts.	The settings and operation of the CPU Unit and programming concepts for motion control are described.
NJ/NX-series Motion Control Instructions Reference Manual	W508	NX701-□□□□ NX102-□□□□ NX1P2-□□□□ NJ501-□□□□ NJ301-□□□□ NJ101-□□□□	Learning about the specifications of the motion control instructions.	The motion control instructions are described.

Manual name	Cat. No.	Model numbers	Application	Description
NJ/NX-series CPU Unit Built-in EtherCAT® Port User's Manual	W505	NX701-□□□□ NX102-□□□□ NX1P2-□□□□ NJ501-□□□□ NJ301-□□□□ NJ101-□□□□	Using the built-in EtherCAT port on an NJ/NX-series CPU Unit.	Information on the built-in EtherCAT port is provided. This manual provides an introduction and provides information on the configuration, features, and setup.
NJ/NX-series CPU Unit Built-in EtherNet/IP™ Port User's Manual	W506	NX701-□□□□ NX102-□□□□ NX1P2-□□□□ NJ501-□□□□ NJ301-□□□□ NJ101-□□□□	Using the built-in EtherNet/IP port on an NJ/NX-series CPU Unit.	Information on the built-in EtherNet/IP port is provided. Information is provided on the basic setup, tag data links, and other features.
NJ/NX-series Troubleshooting Manual	W503	NX701-□□□□ NX102-□□□□ NX1P2-□□□□ NJ501-□□□□ NJ301-□□□□ NJ101-□□□□	Learning about the errors that may be detected in an NJ/NX-series Controller.	Concepts on managing errors that may be detected in an NJ/NX-series Controller and information on individual errors are described.
Sysmac Studio Version 1 Operation Manual	W504	SYSMAC -SE2□□□	Learning about the operating procedures and functions of the Sysmac Studio.	Describes the operating procedures of the Sysmac Studio.
NX-series EtherCAT® Coupler Unit User's Manual	W519	NX-ECC□□□	Learning how to use the NX-series EtherCAT Coupler Unit and EtherCAT Slave Terminals.	The following items are described: the overall system and configuration methods of an EtherCAT Slave Terminal (which consists of an NX-series EtherCAT Coupler Unit and NX Units), and information on hardware, setup, and functions to set up, control, and monitor NX Units through EtherCAT.
NX-series Data Reference Manual	W525	NX-□□□□□□	Referencing lists of the data that is required to configure systems with NX-series Units.	Lists of the power consumptions, weights, and other NX Unit data that is required to configure systems with NX-series Units are provided.
NX-series NX Units User's Manual	W521	NX-ID□□□□ NX-IA□□□□ NX-OC□□□□ NX-OD□□□□ NX-MD□□□□	Learning how to use NX Units.	Describes the hardware, setup methods, and functions of the NX Units. Manuals are available for the following Units. Digital I/O Units, Analog I/O Units, System Units, Position Interface Units, Communications Interface Units, Load Cell Input Unit, and IO-Link Master Units.
	W522	NX-AD□□□□ NX-DA□□□□		
	W592	NX-HAD□□□		
	W566	NX-TS□□□□ NX-HB□□□□		
	W523	NX-PD1□□□ NX-PF0□□□ NX-PC0□□□ NX-TBX01		
	W524	NX-EC0□□□ NX-ECS□□□ NX-PG0□□□		
	W540	NX-CIF□□□		
	W565	NX-RS□□□□		
	W567	NX-ILM□□□		

Manual name	Cat. No.	Model numbers	Application	Description
NX-series Safety Control Unit User's Manual	Z930	NX-SL□□□□ NX-SI□□□□ NX-SO□□□□	Learning how to use NX-series Safety Control Units.	Describes the hardware, setup meth- ods, and functions of the NX-series Safety Control Units.
NA-series Programmable Terminal Software User's Manual	V118	NA5-□W□□□□	Learning about NA- series PT pages and object functions.	Describes the pages and object functions of the NA-series Program- mable Terminals.
NS-series Programmable Terminals Programming Manual	V073	NS15-□□□□□ NS12-□□□□□ NS10-□□□□□ NS8-□□□□□ NS5-□□□□□	Learning how to use the NS-series Pro- grammable Termi- nals.	Describes the setup methods, func- tions, etc. of the NS-series Program- mable Terminals.

Terminology

Term	Description
AT	One of the attributes of a variable. This attribute allows the user to specify what is assigned to a variable. An I/O port or an address in memory used for CJ-series Units can be specified.
CJ-series Unit	Any of the CJ-series Units that can be used with an NJ-series Controller.
memory used for CJ-series Units	One type of I/O memory that contains addresses to which variables can be assigned, for example, when accessing a CJ-series Unit or CJ-series network. It can be accessed only with variables with an AT attribute.
CPU Unit	The Unit that serves as the center of control for a Machine Automation Controller. The CPU Unit executes tasks, refreshes I/O for other Units and slaves, etc. The NJ/NX-series CPU Units include the NX701-□□□□, NX102-□□□□, NX1P2-□□□□, NJ501-□□□□.
EtherCAT Master Function Module	One of the function modules. This function module controls the EtherCAT slaves as the EtherCAT master.
EtherNet/IP Function Module	One of the function modules. This function module controls the built-in EtherNet/IP port.
FB	An acronym for "function block."
FUN	An abbreviation for "function."
I/O port	A logical interface that is used by the CPU Unit to exchange data with an external device (slave or Unit).
I/O map settings	Settings that assign variables to I/O ports. Assignment information between I/O ports and variables.
I/O refreshing	Cyclic data exchange with external devices that is performed with predetermined memory addresses.
MC Test Run	A function to check motor operation and wiring from the Sysmac Studio.
NX bus	The NX-series internal bus. NX102 and NX1P2 CPU Units have the NX bus.
NX Bus Function Module	One of the function modules. This function module controls NX Units attached to the right side of the CPU Unit.
NX Units	Any of the NX-series Units that perform I/O processing with connected external devices. The Communications Coupler Units are not included with the NX Units.
PDO communications	An abbreviation for process data communications. Data is exchanged between the master and slaves on a process data communications cycle. (The process data communications cycle is the same as the task period of the primary periodic task.)
PLC Function Module	One of the function modules. This function module executes the user program, sends commands to the Motion Control Function Module, and provides an interface to the USB and SD Memory Card.
POU	An acronym for "program organization unit". A POU is a unit in a program execution model that is defined in IEC 61131-3. A POU contains an algorithm and a local variable table and forms the basic unit used to build a user program. There are three types of POUs: programs, functions, and function blocks.
SDO communications	One type of EtherCAT communications in which service data objects (SDOs) are used to transmit information whenever required.
Sysmac Studio	A computer software application for setting, programming, debugging, and troubleshooting NJ/NX-series Controllers. It also provides operations for motion control and a Simulator.
upload	To transfer data from the Controller to the Sysmac Studio with the synchronization operation of the Sysmac Studio.
information	One of the event levels for Controller events or user-defined events. These are not errors, but appear in the event log to notify the user of specific information.
Event Setup	Settings that define user-defined errors and user-defined information.
event task	A task that executes a user program only once when the task execution conditions are met.
event log	A function that recognizes and records errors and other events.
inline ST	ST programming that is included within a ladder diagram.

Term	Description
edge	One of the attributes of a variable. This attribute makes a BOOL variable pass TRUE to a function block when the variable changes from FALSE to TRUE or when it changes from TRUE to FALSE.
cam data variable	A variable that represents the cam data as a structure array. A cam data variable is an array structure that consists of phases and displacements.
observation	One of the event levels for Controller events or user-defined events. These are minor errors that do not affect control operations, but appear in the event log to notify the user of specific information.
function module	One of the functional units of the software configuration of the CPU Unit.
basic data type	Any of the data types that are defined by IEC 61131-3. They include Boolean, bit string, integer, real, duration, date, time of day, date and time, and text string data types. "Basic data type" is used as opposed to derivative data types, which are defined by the user.
forced refreshing	Forcing the refreshing of an input from an external device or an output to an external device, e.g., when the user debugs a program. Addresses that are subject to forced refreshing can still be overwritten from the user program.
union	One of the derivative data types. It allows you to handle the same data as different data types.
global variable	A variable that can be read or written from all POU's (programs, functions, and function blocks).
minor fault level Controller error	An error for which some of the control operations for one of the function modules in the NJ/NX-series Controller stop. An NJ/NX-series CPU Unit continues operation even after a minor fault level Controller error occurs.
Special Unit Setup	A generic term for the settings for a Special Unit, including the settings in allocated DM Area words.
structure	One of the derivative data types. It consists of multiple data types placed together into a layered structure.
Constant	One of the attributes of a variable. If you specify the Constant attribute for a variable, the value of the variable cannot be written by any instructions, ST operators, or CIP message communications.
Controller	The range of devices that are directly controlled by the CPU Unit. In the NX-series System, the Controller includes the CPU Rack and EtherCAT slaves (including general-purpose slaves and Servo Drives). In the NJ-series System, the Controller includes the CPU Rack, Expansion Racks, and EtherCAT slaves (including general-purpose slaves and Servo Drives).
Controller error	Errors that are defined by the NJ/NX-series System. "Controller error" is a collective term for major fault level, partial fault level, minor fault level, and observation Controller events.
Controller event	One of the events in the NJ/NX-series System. Controller events are errors and information that are defined by the system for user notification. A Controller event occurs when the system detects a factor that is defined as a Controller event.
Controller information	Information that is defined by the NJ/NX-series System that is not an error. It represents an information Controller event.
Servo Drive/encoder input slave	Any of the EtherCAT slaves that is assigned to an axis. In the NJ/NX-series System, it would be a Servo Drive or Encoder Input Slave Unit.
axis	A functional unit within the Motion Control Function Module. An axis is assigned to the drive mechanism in an external Servo Drive or the sensing mechanism in an external Encoder Input Slave Unit.
axes group	A functional unit that groups together axes within the Motion Control Function Module.
Axes Group Variable	A system-defined variable that is defined as a structure and provides status information and some of the axes parameters for an individual axes group. An Axes Group Variable is used to specify an axes group for motion control instructions and to monitor the command interpolation velocity, error information, and other information for the axes group.

Term	Description
Axis Variable	A system-defined variable that is defined as a structure and provides status information and some of the axis parameters for an individual axis. An Axis Variable is used to specify an axis for motion control instructions and to monitor the command position, error information, and other information for the axis.
system common processing	System processing that is performed by the CPU Unit to perform I/O refreshing and the user program execution within a task. Exclusive control of variables between tasks, data trace processing, and other processing is performed.
system service	Processing that is performed by the CPU Unit in unused time between task processing. The system service includes communications processing, SD Memory Card access processing, self-diagnosis processing, and other processing.
system-defined variable	A variable for which all attributes are defined by the system and cannot be changed by the user.
Initial Value	One of the attributes of a variable. The variable is set to the initial value in the following situations. <ul style="list-style-type: none"> • When power is turned ON • When the CPU Unit changes to RUN mode • When you specify to initialize the values when the user program is transferred • When a major fault level Controller error occurs
slave	A device that performs remote I/O for a master.
Slave Terminal	A building-block remote I/O terminal to which a Communications Coupler Unit and NX Units are mounted. A Slave Terminal is one type of slave.
slave and Unit configurations	A generic term for the EtherCAT configuration and Unit configuration.
absolute encoder home offset	This data is used to restore in the CPU Unit the actual position of a Servo Drive with an absolute encoder. The offset is the difference between the command position after homing and the absolute data that is read from the absolute encoder.
project unit version	A unit version to be set for the project. It is set for the project in the Select Device Area of the Project Properties Dialog Box on the Sysmac Studio.
major fault level Controller error	An error for which all NJ/NX-series Controller control operations stop. The CPU Unit immediately stops user program execution and turns OFF the loads for all slaves and Units (including remote I/O).
download	To transfer data from the Sysmac Studio to the Controller with the synchronization operation of the Sysmac Studio.
task	An attribute that defines when a program is executed.
task period	The interval at which the primary periodic task or a periodic task is executed.
Communications Coupler Unit	The generic name of an interface unit for remote I/O communications on a network between NX Units and a host network master. For example, an EtherCAT Coupler Unit is a Communications Coupler Unit for an EtherCAT network.
periodic task	A tasks for which user program execution and I/O refreshing are performed each period.
device	A general term for any Unit or slave that is refreshed by the I/O refreshing that is performed by the CPU Unit. Specifically, it refers to EtherCAT slaves, NX Units on the CPU Unit, built-in I/O, Option Boards, and CJ-series Units.
device output	An output for any Unit or slave that is refreshed by the I/O refreshing that is performed by the CPU Unit.
device variable	A variable that is used to access a specific device through an I/O port.
synchronization	A function that automatically compares the information in the NJ/NX-series Controller with the information in the Sysmac Studio, displays any differences and locations in a hierarchical form, and can be used to synchronize the information.
namespace	A system that is used to group and nest the names of functions, function block definitions, and data types.
Network Publish	One of the attributes of a variable. This attribute allows you to use CIP message communications or tag data links to read/write variables from another Controller or from a host computer.
array specification	One of the variable specifications. An array variable contains multiple elements of the same data type. The elements in the array are specified by serial numbers called subscripts that start from the beginning of the array.

Term	Description
derivative data type	A data type that is defined by the user. Structures, unions, and enumerations are derivative data types.
Range Specification	One of the variable specifications. You can specify a range for a variable in advance. The variable can take only values that are in the specified range.
general-purpose slave	Any of the EtherCAT slaves that cannot be assigned to an axis.
function	A POU that is used to create an object that determines a unique output for the same input, such as for data processing.
function block	A POU that is used to create an object that can have a different output for the same input, such as for a timer or counter.
partial fault level Controller error	An error for which all of the control operations for one of the function modules in the NJ/NX-series Controller stop. An NJ/NX-series CPU Unit continues operation even after a partial fault level Controller error.
primary periodic task	The task with the highest priority.
program	Along with functions and function blocks, one of the three types of POUs. Programs are assigned to tasks to execute them.
process data communications	One type of EtherCAT communications in which process data objects (PDOs) are used to exchange information cyclically and in realtime. Process data communications are also called PDO communications.
variable	A representation of data, such as a numeric value or character string, that is used in a user program. You can change the value of a variable by assigned the required value. "Variable" is used as opposed to "constant," for which the value does not change.
variable memory	A memory area that contains the present values of variables that do not have AT specifications. It can be accessed only with variables without an AT attribute.
Retain	One of the attributes of a variable. The values of variables with a Retain attribute are held at the following times. (Variables without a Retain attribute are set to their initial values.) <ul style="list-style-type: none"> • When power is turned ON after a power interruption • When the CPU Unit changes to RUN mode • When you specify to not initialize the values when the user program is transferred
instruction	The smallest unit of the processing elements that are provided by OMRON for use in POU algorithms. There are ladder diagram instructions (program inputs and outputs), function instructions, function block instructions, and ST statements.
main memory	The memory inside the CPU Unit that is used by the CPU Unit to execute the OS and user program.
Motion Control Function Module	One of the function modules. The MC Function Module performs motion control based on commands from the motion control instructions that are executed in the user program.
motion control instruction	A function block instruction that executes motion control. The Motion Control Function Module supports instructions that are based on function blocks for PLCopen® motion control as well as instructions developed specifically for the Motion Control Function Module.
user-defined event	One of the events in the NJ/NX-series System. These events are defined by the user. "User-defined events" is a generic term for user-defined errors and user-defined information.
user-defined variable	A variable for which all of the attributes are defined by the user and can be changed by the user.
user program	All of the programs in one project.
Unit	A device that mounts to the CPU Rack or an Expansion Rack.
Unit configuration	The configuration information for the Units that are set on the Sysmac Studio. This information tells what Unit models are connected to the CPU Unit and where they are connected.
literal	A constant expression that is used in a user program.
enumeration	One of the derivative data types. This data type takes one item from a prepared name list of enumerators as its value.
enumerator	One of the values that an enumeration can take expressed as a character string. The value of an enumeration is one of the enumerators.

Term	Description
local variable	A variable that can be accessed only from inside the POU in which it is defined. "Local variable" is used as opposed to "global variable." Local variables include internal variables, input variables, output variables, in-out variables, and external variables.

Revision History

A manual revision code appears as a suffix to the catalog number on the front and back covers of the manual.

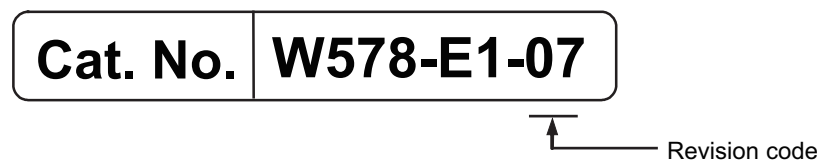

Revision code	Date	Revised content
01	October 2016	Original production
02	April 2017	Made changes accompanying release of unit version 1.14 of the CPU Unit.
03	October 2017	Made changes accompanying release of unit version 1.16 of the CPU Unit. Added Shipbuilding Standard (LR).
04	April 2018	Corrected mistakes.
05	April 2019	Made changes accompanying release of unit version 1.21 of the CPU Unit. Corrected mistakes.
06	July 2019	Made changes accompanying release of unit version 1.40 of the CPU Unit.
07	October 2019	Added information on the NX1P2-9B□□□□□.

1

Introduction to NX-series Controllers

This section describes the features, basic system configuration, specifications, and overall operating procedure of an NX-series Controller NX1P2.

1-1	The NX-series Controller	1-2
1-1-1	Features.....	1-3
1-1-2	Introduction to the System Configurations.....	1-6
1-2	Specifications	1-9
1-3	Overall Operating Procedure for the CPU Unit	1-14
1-3-1	Overall Procedure.....	1-14
1-3-2	Procedure Details	1-15

1-1 The NX-series Controller

The SYSMAC NX-series are next-generation machine automation controllers that provide the functionality and high-speed performance that are required for machine control. They provide the safety, reliability, and maintainability that are required of industrial controllers.

The NX-series Controllers provide the functionality of previous OMRON PLCs, and they also provide the functionality that is required for motion control. Synchronized control of I/O devices on high-speed EtherCAT can be applied to safety devices, vision systems, motion equipment, discrete I/O, and more. Especially, the NX-series NX1P2 Controller can perform I/O operation with a mounted NX Unit or Option Board, and with the built-in I/O.

OMRON offers the new Sysmac Series of control devices designed with unified communications specifications and user interface specifications. The NX-series Machine Automation Controllers are part of the Sysmac Series. You can use them together with EtherCAT slaves, other Sysmac products, and the Sysmac Studio Automation Software to achieve optimum functionality and ease of operation.

With a system that is created from Sysmac products, you can connect components and commission the system through unified concepts and usability.

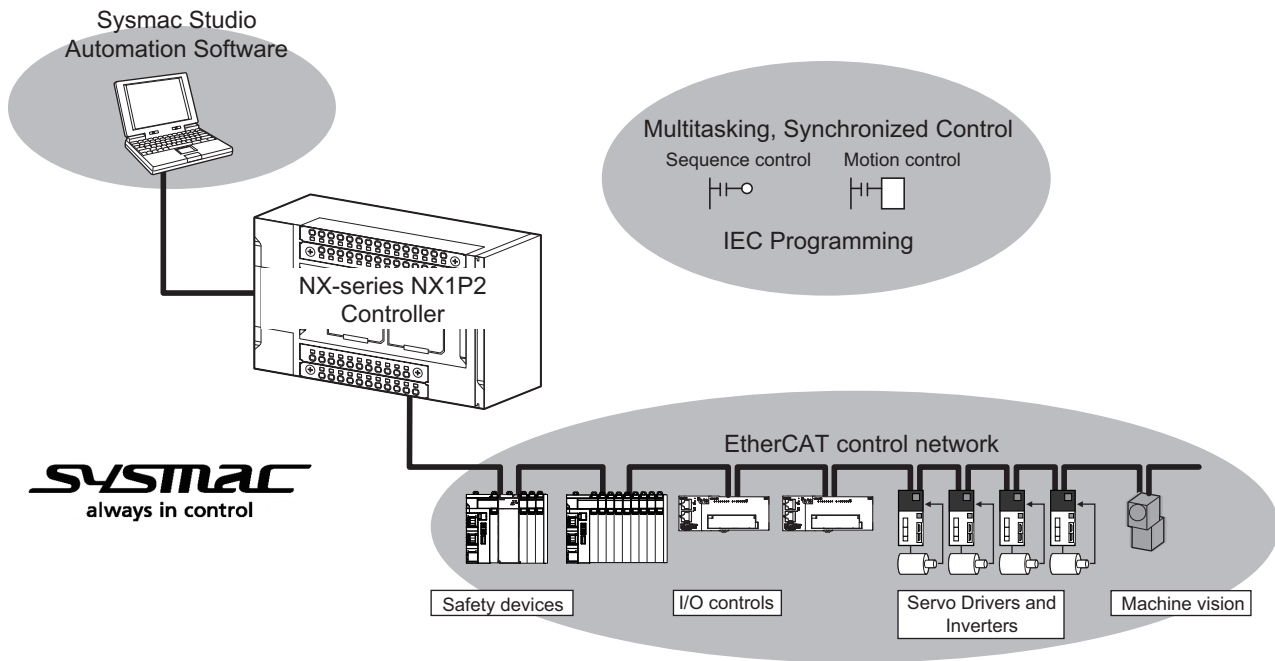

1-1-1 Features

Hardware Features

● Standard-feature EtherCAT Control Network Support

All CPU Units provide an EtherCAT master port for EtherCAT communications.

EtherCAT is an advanced industrial network system that achieves faster, more-efficient communications. It is based on Ethernet. Each node achieves a short fixed communications cycle time by transmitting Ethernet frames at high speed.

The standard-feature EtherCAT control network allows you to connect all of the devices required for machine control (e.g., I/O systems, Servo Drives, Inverters, and machine vision) to the same network.

● Support for EtherCAT Slave Terminals

You can use EtherCAT Slave Terminals to save space. You can also flexibly build systems with the wide variety of NX Units.

● Achieving a Safety Subsystem on EtherCAT

You can use NX-series Safety Control Units to integrate safety controls in a sequence and motion control system as a subsystem on EtherCAT.

● Standard-feature EtherNet/IP Communications Port

A CPU Unit provides an EtherNet/IP communications port for EtherNet/IP communications as a standard feature.

EtherNet/IP is a multi-vendor industrial network that uses Ethernet. You can use it for networks between Controllers or as a field network. The use of standard Ethernet technology allows you to connect to many different types of general-purpose Ethernet devices.

● Built-in I/O Available

The Controller has the built-in I/O. You can connect small I/O devices inside the control panel at a low cost.

● NX-series Units Connectable

Up to eight NX Units including NX-series Digital I/O Units, Analog I/O Units, and other I/O Units can be connected to the CPU Unit.



Precautions for Correct Use

You cannot mount NX-series Safety Control Units on the CPU Unit and use them. Use NX-series Safety Control Units as a subsystem on EtherCAT.

● Option Boards Connectable

One or two Option Boards to add the serial communications or analog I/O function can be connected to the CPU Unit.

The Serial Communications Option Board enables you to connect general-purpose components such as a bar code reader.

The Analog I/O Option Board allows inputs from devices such as variable resistors, process-control sensor, and inverter control.

● **Battery-free Operation**

The following data (other than the clock data) is retained in the built-in non-volatile memory.

- User program
- Set values
- Variables retained during power interruption
- Event logs

The retention period for the clock data is limited*1.

When the clock data is not needed or the equipment's power OFF time is shorter than the clock data retention period, the battery-free operation is possible and man-hours for battery replacement can be reduced.

If you turn OFF the power supply to the equipment for a longer period of time than the clock data retention period, mount a battery which is sold separately.

*1. Approximately 10 days at an ambient temperature of 40°C. Refer to *3-1-5 Battery* on page 3-18 for detail.

● **Standard-feature SD Memory Card Slot**

You can access an SD Memory Card that is mounted in the CPU Unit from the user program.

● **Highly Reliable Hardware**

The NX-series Controllers provide the hardware reliability and RAS functions that you expect of a PLC.

Software Features

● **Integrated Sequence Control and Motion Control**

An NX-series CPU Unit can perform both sequence control and motion control. You can simultaneously achieve both sequence control and multi-axes synchronized control. Sequence control, motion control, and I/O refreshing are all executed in the same control period.

The same control period is also used for the process data communications cycle for EtherCAT. This enables precise sequence and motion control in a fixed period with very little deviation.

● **Programming Languages Based on the IEC 61131-3 International Standard**

The NJ-series Controllers support language specifications that are based on IEC 61131-3. To these, OMRON has added our own improvements. Motion control instructions that are based on PLCopen® standards and an instruction set (POUs) that follows IEC rules are provided.

● **Programming with Variables to Eliminate Worrying about the Memory Map**

You access all data through variables in the same way as for the advanced programming languages that are used on computers. Memory in the CPU Unit is automatically assigned to the variables that you create so that you do not have to remember the physical addresses.

- **A Wealth of Security Features**

The many security features of the NX-series Controllers include operation authority settings and restriction of program execution with IDs.

- **Complete Controller Monitoring**

The CPU Unit monitors events in all parts of the Controller, including mounted NX Units and EtherCAT slaves.

Troubleshooting information for errors is displayed on the Sysmac Studio or on an NS-series PT. Events are also recorded in logs.

- **Sysmac Studio Automation Software**

The Sysmac Studio provides an integrated development environment that covers not only the Controller, but also covers peripheral devices and devices on EtherCAT. You can use consistent procedures for all devices regardless of the differences in the devices. The Sysmac Studio supports all phases of Controller application, from designing through debugging, simulations, commissioning, and changes during operation.

- **A Wealth of Simulation Features**

The many simulation features include execution, debugging, and task execution time estimates on a virtual controller.

1-1-2 Introduction to the System Configurations

The NX-series Controller NX1P2 supports the following system configurations.

Basic System Configurations

The NX-series Controller NX1P2 basic configurations include the EtherCAT network configuration, NX Unit configuration, and the Support Software.

- EtherCAT Network Configuration

You can use the built-in EtherCAT port to connect to EtherCAT Slave Terminals, to general-purpose slaves for analog and digital I/O, and to Servo Drives and encoder input slaves. An EtherCAT network configuration enables precise sequence and motion control in a fixed cycle with very little deviation.

- NX Unit configuration

The CPU Unit can be connected with up to eight NX Units (NX-□□□□□□) including NX-series Digital I/O Units, Analog I/O Units, and other I/O Units. These NX Units can be flexibly combined with the CPU Unit and configure a CPU Rack to support various applications.

- Support Software

You can connect the Support Software through an Ethernet cable that is connected to the built-in EtherNet/IP port in the CPU Unit.

Refer to 3-7-2 *Connection* on page 3-33 for details on the connection configuration of the Support Software.

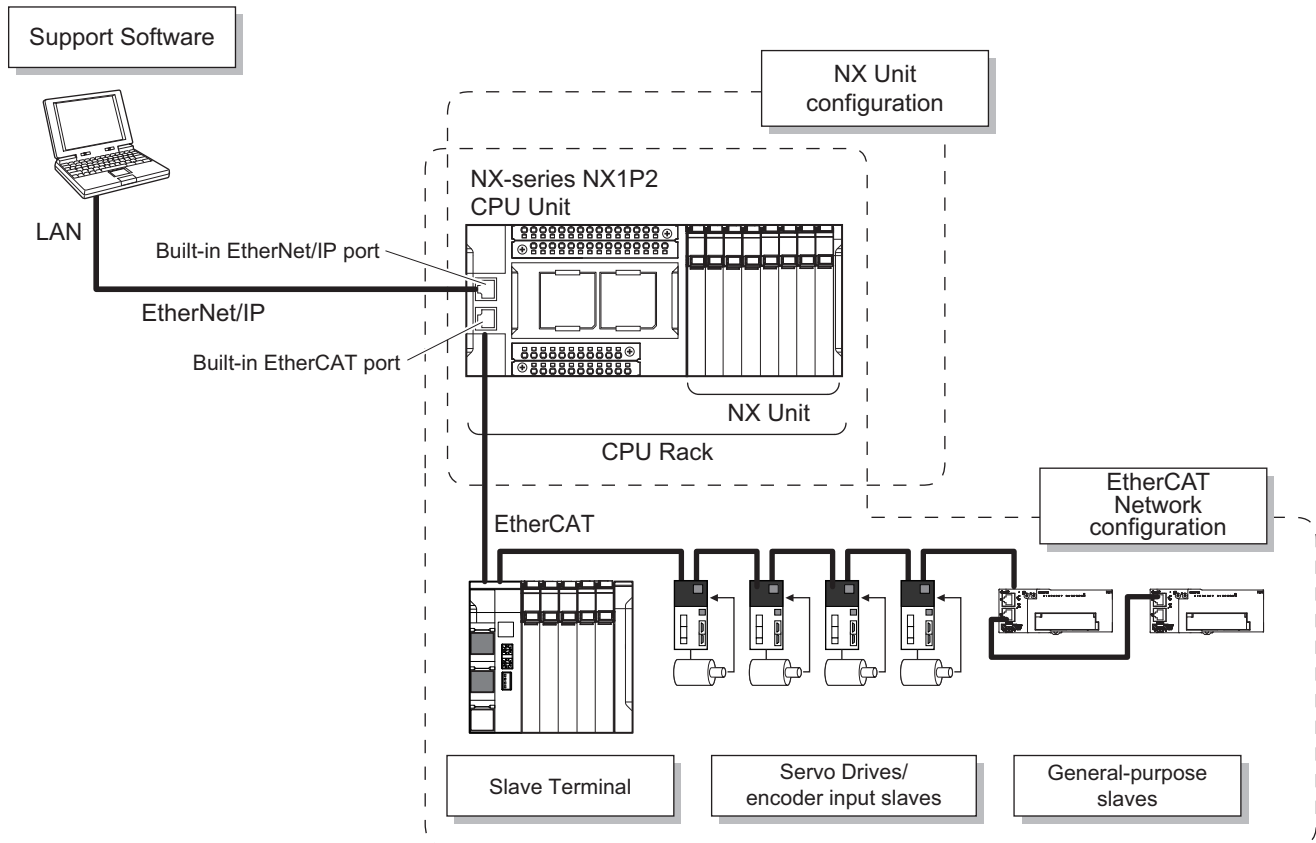

Network Configurations

- Host computers, HMIs, and other NJ/NX-series Controllers are connected to the built-in EtherNet/IP port.
- A DeviceNet network is connected to a CJ-series DeviceNet Unit mounted to the NJ-series CPU Unit.
- A serial communications network is connected to the following Units.
Serial Communications Option Board
NX-series Communications Interface Unit
CJ-series Serial Communications Unit

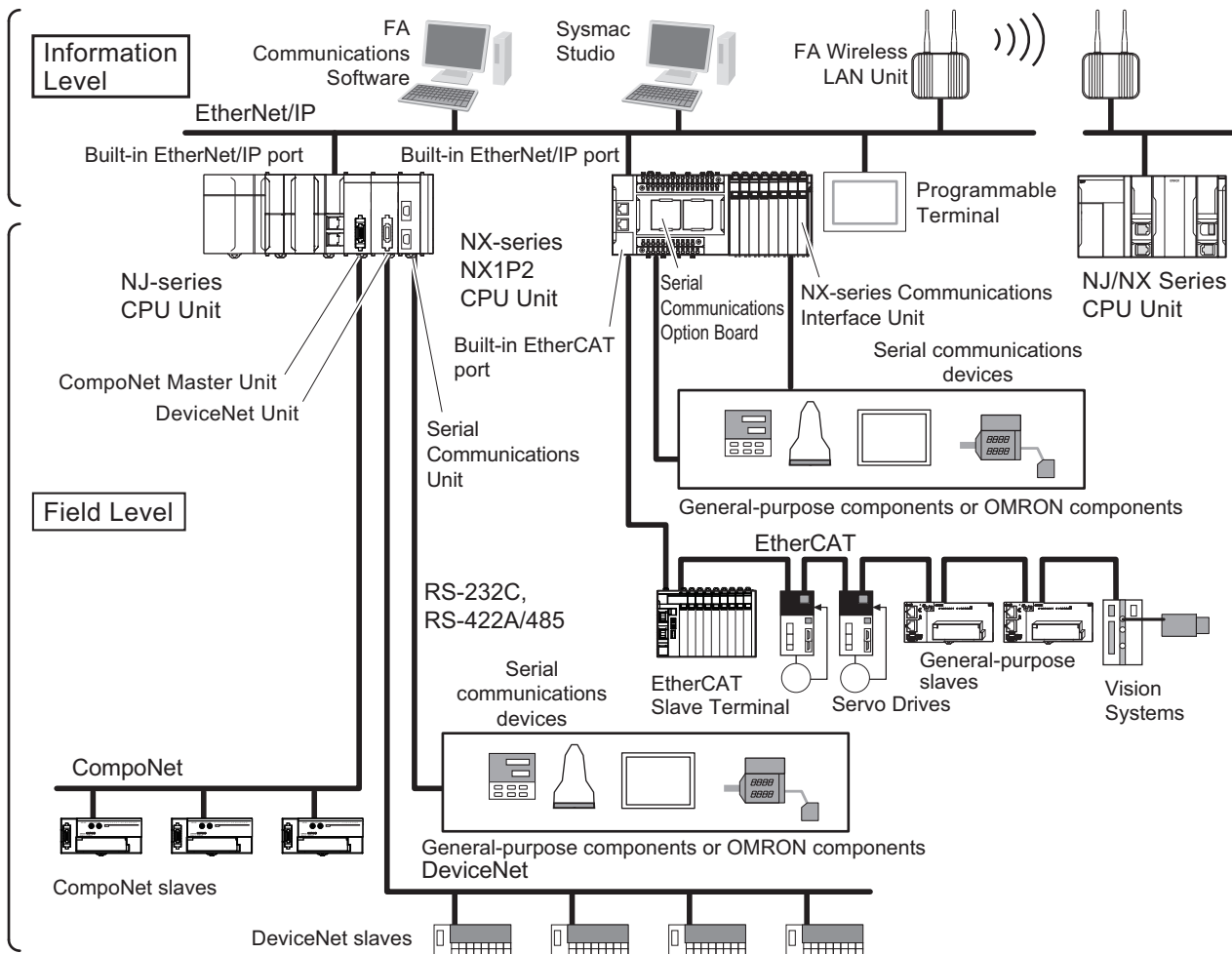

Refer to the *NJ/NX-series CPU Unit Software User's Manual (Cat. No. W501)* for details on the network configuration.

Support Software

You can use the following Support Software to set up, monitor, and debug an NX-series Controller.

- **Sysmac Studio**

The Sysmac Studio is the main Support Software that you use for an NX-series Controller. On it, you can set up the Controller configurations, parameters, and programs, and you can debug and simulate operation.

- **Other Support Software**

The following Support Software is also included in the Sysmac Studio Software Package Standard Edition.

Configuration software	Application
Sysmac Studio	The Sysmac Studio is used for sequence control, motion control, and all other operations except those described below.
Network Configurator	The Network Configurator is used for tag data links on EtherNet/IP ports. *1
CX-Integrator	The CX-Integrator is used for remote I/O communications with a CJ-series DeviceNet Unit or CJ-series CompoNet Master Unit.
CX-Protocol	The CX-Protocol is used for protocol macros with the CJ-series Serial Communications Units.
CX-Designer	The CX-Designer is used to create screens for NS-series PTs.

*1. If the NJ/NX-series Controller is a target device, you may also use Sysmac Studio version 1.10 or higher. Use the Network Configurator if a CS/CJ-series PLC operates as the originator device.

1-2 Specifications

This section gives the main specifications of the NX-series NX1P2 CPU Units.

Item			NX1P2-				
			11□□□□/ 11□□□□1	10□□□□/ 10□□□□1	90□□□□/ 90□□□□1	9B□□□□/ 9B□□□□1	
Proc- essing time	Instruction execution times	LD instruction	3.3 ns				
		Math instructions (for long real data)	70 ns or more				
Pro- gram- ming	Program ca- pacity* ¹	Size	1.5 MB		1.0 MB		
		Quantity	Number of POU defi- nitions	450			
			Number of POU in- stances	1,800			
		Memory ca- pacity for variables* ²	Retain at- tributes	Size	32 kB		
	Number of variables			5,000			
	No Retain attributes		Size	2 MB			
			Number of variables	90,000			
	Data types	Number of data types	1,000				
	Memory for CJ-series Units (Can be specified with AT specifica- tions for var- iables.)	CIO Area	0 to 6,144 words (0 to 6,143) ^{*3}				
		Work Area	0 to 512 words (W0 to W511) ^{*3}				
		Holding Area	0 to 1,536 words (H0 to H1,535) ^{*4}				
		DM Area	0 to 16,000 words (D0 to D15,999) ^{*4}				
EM Area		---					

Item			NX1P2-			
			11□□□□/ 11□□□□1	10□□□□/ 10□□□□1	90□□□□/ 90□□□□1	9B□□□□/ 9B□□□□1
Motion control	Number of controlled axes*5	Maximum number of controlled axes	12 axes	10 axes	4 axes	2 axes
		Motion control axes	8 axes	6 axes	---	
		Single-axis position control axes	4 axes			2 axes
		Maximum number of used real axes	8 axes	6 axes	4 axes	2 axes
		Used motion control servo axes	4 axes	2 axes	---	
		Used single-axis position control servo axes	4 axes			2 axes
		Maximum number of axes for linear interpolation axis control	4 axes per axes group		---	
		Number of axes for circular interpolation axis control	2 axes per axes group		---	
		Maximum number of axes groups	8 axes groups		---	
		Motion control period	Same as the period for primary periodic task			
	Cams	Number of cam data points	Maximum points per cam table	65,535 points		---
			Maximum points for all cam tables	262,140 points		---
		Maximum number of cam tables	80 tables		---	
	Position units	Pulse, mm, μm, nm, degree, and inch				
	Override factors	0.00% or 0.01% to 500.00%				

Item		NX1P2-				
		11□□□□/ 11□□□□1	10□□□□/ 10□□□□1	90□□□□/ 90□□□□1	9B□□□□/ 9B□□□□1	
Built-in Ether- Net/IP port	Number of ports	1				
	Physical layer	10BASE-T, 100BASE-TX				
	Frame length	1,514 bytes max.				
	Media access method	CSMA/CD				
	Modulation	Baseband				
	Topology	Star				
	Baud rate	100 Mbps (100BASE-TX)				
	Transmission media	STP (shielded, twisted-pair) cable of Ethernet category 5, 5e or higher				
	Maximum transmission distance between Ethernet switch and node	100 m				
	Maximum number of cascade connections	There are no restrictions if an Ethernet switch is used.				
	CIP service: Tag data links (cyclic communications)	Maximum number of connections	32			
		Packet interval ^{*6}	Can be set for each connection. 2 to 10,000 ms in 1-ms increments			
		Permissible communications band	3,000 pps ^{*7} (including heartbeat)			
		Maximum number of tag sets	32			
		Tag types	Network variables CIO, Work, Holding and DM Areas			
		Number of tags per connection (i.e., per tag set)	8 (7 tags if Controller status is included in the tag set.)			
		Maximum number of tags	256			
		Maximum link data size per node (total size for all tags)	19,200 bytes			
		Maximum data size per connection	600 bytes			
		Maximum number of registrable tag sets	32 (1 connection = 1 tag set)			
	Maximum tag set size	600 bytes (Two bytes are used if Controller status is included in the tag set.)				
Multi-cast packet filter ^{*8}	Supported					
CIP message service: Explicit messages	Class 3 (number of connections)	32 (clients plus server)				
	UCMM (non-connection type)	Maximum number of clients that can communicate at one time	32			
		Maximum number of servers that can communicate at one time	32			
Number of TCP sockets	30					

Item		NX1P2-				
		11□□□□/ 11□□□□1	10□□□□/ 10□□□□1	90□□□□/ 90□□□□1	9B□□□□/ 9B□□□□1	
Built-in Ether-CAT port	Communications standard	IEC 61158 Type12				
	EtherCAT master specifications	Class B (Feature Pack Motion Control compliant)				
	Physical layer	100BASE-TX				
	Modulation	Baseband				
	Baud rate	100 Mbps (100BASE-TX)				
	Duplex mode	Auto				
	Topology	Line, daisy chain, branching and ring*9				
	Transmission media	Twisted-pair cable of category 5 or higher (double-shielded straight cable with aluminum tape and braiding)				
	Maximum transmission distance between nodes	100 m				
	Maximum number of slaves	16	8			
	Range of node addresses that can be set	1 to 192				
	Maximum process data size	Input: 1,434 bytes Output: 1,434 bytes *10				
	Maximum process data size per slave	Input: 1,434 bytes Output: 1,434 bytes				
	Communications cycle	2,000 μs to 8,000 μs in 250-μs increments			4,000 μs to 8,000 μs in 250-μs increments	
Sync jitter	1 μs max.					
Serial Communications (Serial Communications Option Board)	Communications method	Half duplex				
	Synchronization method	Start-stop synchronization				
	Baud rate	1.2/2.4/4.8/9.6/19.2/38.4/57.6/115.2 kbps				
	Transmission distance	Depends on Option Board.				
	Supported protocol	Host link, Modbus-RTU master, and no-protocol				
Unit configuration	Maximum number of connectable Units	Maximum number of NX Units that can be mounted to the CPU Unit	8			
		Maximum number of NX Units for entire controller	24 On CPU Rack: 8 On EtherCAT Slave Terminals: 16			
	Power supply	Model	A non-isolated power supply for DC input is built into the CPU Unit.			
		Power OFF detection time	2 to 8 ms			
Option Board	Number of slots	2	2	1		
Built-in I/O	Input	Number of points	24	24	14	*11
	Output	Number of points	16	16	10	*12
		Load-short circuit protection	11□□DT/10□□DT/9024DT/9B□□DT: Not provided(NPN) 11□□DT1/10□□DT1/9024DT1/9B□□DT1: Provided(PNP)			

Item		NX1P2-			
		11□□□□/ 11□□□□1	10□□□□/ 10□□□□1	90□□□□/ 90□□□□1	9B□□□□/ 9B□□□□1
Internal clock	Accuracy	At ambient temperature of 55°C: -3.5 to 0.5 min error per month At ambient temperature of 25°C: -1.5 to 1.5 min error per month At ambient temperature of 0°C: -3 to 1 min error per month			
	Retention time of built-in capacitor	At ambient temperature of 40°C: 10 days			

- *1. Execution objects and variable tables (including variable names)
- *2. Memory used for CJ-series Units is included.
- *3. The value can be set in 1-word increments. The value is included in the total size of variables without a Retain attribute.
- *4. The value can be set in 1-word increments. The value is included in the total size of variables with a Retain attribute.
- *5. Refer to the *NJ/NX-series CPU Unit Motion Control User's Manual (Cat. No. W507)* for description of this term.
- *6. Data will be refreshed at the set interval, regardless of the number of nodes.
- *7. "pps" means packets per second, i.e., the number of communications packets that can be sent or received in one second.
- *8. As the EtherNet/IP port implements the IGMP client, unnecessary multi-cast packets can be filtered by using an Ethernet switch that supports IGMP Snooping.
- *9. A ring topology can be used with project unit version 1.40 or later.
- *10. However, for project unit version earlier than 1.40, the data must be within one frame.
- *11. NX1P2-9B40□□□: 24 and NX1P2-9B24□□□: 14
- *12. NX1P2-9B40□□□: 16 and NX1P2-9B24□□□: 10

1-3 Overall Operating Procedure for the CPU Unit

This section gives the overall operating procedure for the NX1P2 CPU Unit and then describes it in more detail.

1-3-1 Overall Procedure

The overall procedure to use an NX1P2 CPU Unit is given below.

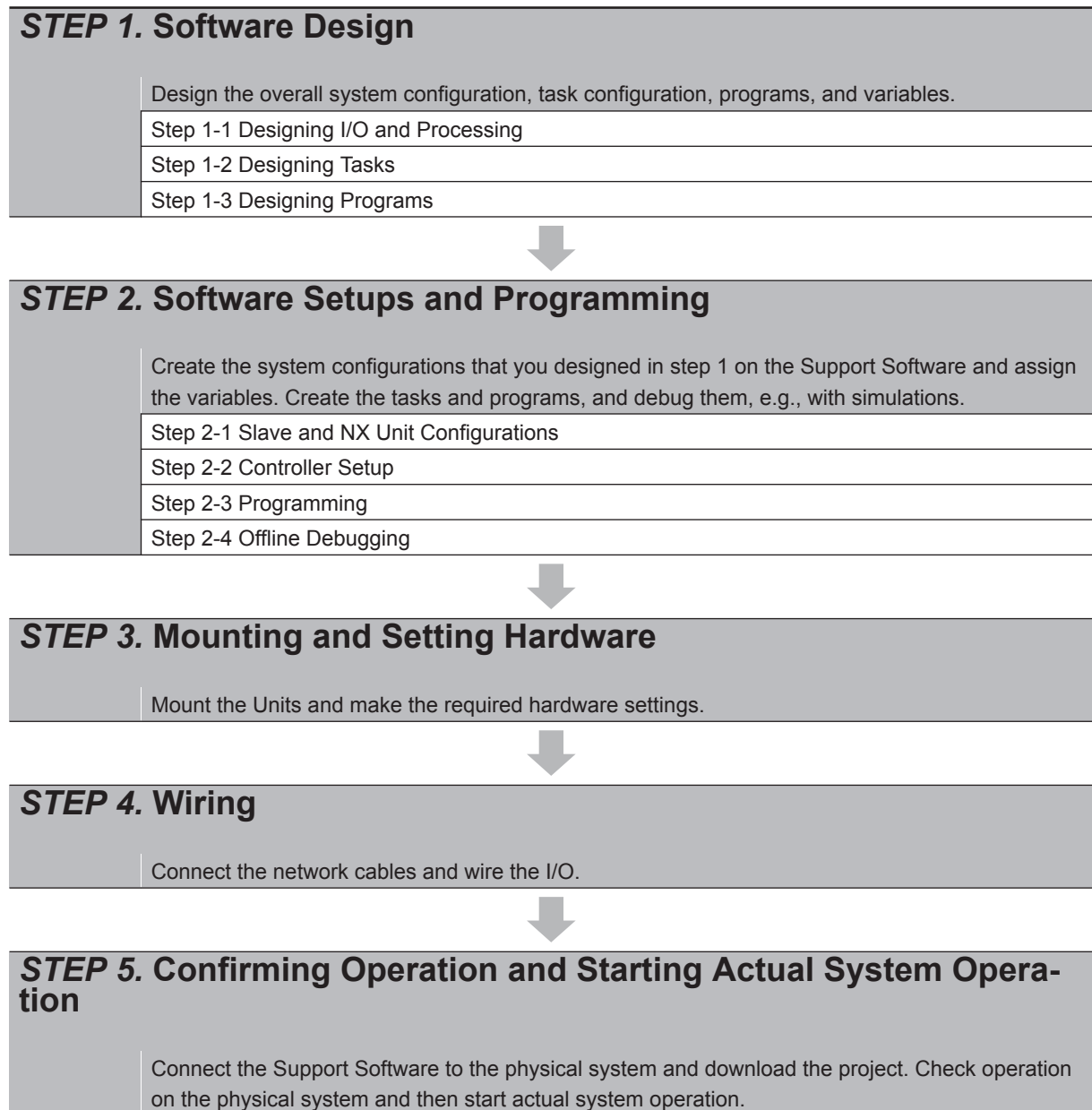

1-3-2 Procedure Details

STEP1. Software Design

Step	Description	Reference
Step 1-1 Designing I/O and Processing	<ul style="list-style-type: none"> External I/O devices and Unit configuration Refresh periods for external devices Program contents 	<i>NJ/NX-series CPU Unit Software User's Manual (Cat. No. W501)</i>



Step 1-2 Designing Tasks	<ul style="list-style-type: none"> Task configuration Relationship between tasks and programs Task periods Slave, NX Unit, and built-in I/O refresh times Exclusive control methods for variables between tasks 	<i>NJ/NX-series CPU Unit Software User's Manual (Cat. No. W501)</i>
-------------------------------------	--	---



Step 1-3 Designing Programs		
POU (Program Organization Unit) Design	<ul style="list-style-type: none"> Programs Functions and function blocks Determining the algorithm languages 	<i>NJ/NX-series CPU Unit Software User's Manual (Cat. No. W501)</i>
Variable Design	<ul style="list-style-type: none"> Defining variables that you can use in more than one POU and variables that you use in only specific POU Defining the variables names for the device variables that you use to access slaves, NX Units, and the built-in I/O Defining the attributes of variables, such as the Name and Retain attributes Designing the data types of variables 	<i>NJ/NX-series CPU Unit Software User's Manual (Cat. No. W501)</i>



STEP2. Software Setups and Programming

Step	Description	Sysmac Studio Operations	Reference
Project Creation	<ol style="list-style-type: none"> Create a project in the Sysmac Studio. Select a Controller. 	Select New Project Select the device in the Project Properties Dialog Box	<i>Sysmac Studio Version 1 Operation Manual (Cat. No. W504)</i>



The following *Controller Configurations* and Setup and the *Programming and Task Settings* can be performed in either order.

Step 2-1 Slave and NX Unit Configurations			
1) Creating the Slave and NX Unit Configurations	<ol style="list-style-type: none"> Creating the slave configuration and NX Unit configuration either offline or online. (For online configuration, make the online connection that is described in step 5.) Setting up any Slave Terminals that are used. 	EtherCAT Tab Page CPU and Expansion Racks Tab Page Slave Terminal Tab Page	<i>NJ/NX-series CPU Unit Software User's Manual (Cat. No. W501)</i> <i>NX-series EtherCAT Coupler Units User's Manual (Cat. No. W519)</i>



2) Assigning Device Variables to I/O Ports	Registering device variables in variable tables (Variable names are user defined or automatically created.)	I/O Map	<i>NJ/NX-series CPU Unit Software User's Manual (Cat. No. W501)</i>
---	---	---------	---



(The following step is for motion control.)

3) Creating the Axes and Assigning Them to the Servo Drive/Encoder Input Slaves	Creating the axes and setting them as real axes or virtual axes. Creating axes groups to perform interpolated axes control.	Configurations and Setup – Motion Control Setup	<i>NJ/NX-series CPU Unit Software User's Manual (Cat. No. W501)</i>
--	--	--	---



Step 2-2 Controller Setup	Setting the following parameters from the Sysmac Studio		<i>NJ/NX-series CPU Unit Software User's Manual (Cat. No. W501)</i>
	Setting the initial values for the PLC Function Module	Configurations and Setup – Controller Setup – Operation Settings	3-1-5 Battery on page 3-18
	Setting the battery-related error detection when the battery is mounted	Configurations and Setup – Controller Setup – Operation Settings	
	Setting the initial values for the NX Bus Function Module	Configurations and Setup – CPU/Expansion Racks – CPU Rack	
	(To use motion control) Setting the initial settings for the Motion Control Function Module	Configurations and Setup – Motion Control Setup	
	Setting the initial values for the EtherCAT Master Function Module	Configurations and Setup – EtherCAT	
	Setting the initial values for the EtherNet/IP Function Module	Configurations and Setup – Controller Setup – Built-in EtherNet/IP Port Settings	
	Setting the initial values for the built-in I/O	Configurations and Setup – Controller Setup – Built-in I/O Settings	<i>NX-series NX1P2 CPU Unit Built-in I/O and Option Board User's Manual (Cat. No. W579)</i>
	Setting the initial values for an Option Board	Configurations and Setup – Controller Setup – Option Board Settings	



Step 2-3 Programming			
1) Registering Variables	<ul style="list-style-type: none"> Registering the variables used by more than one POU in the global variable table with Sysmac Studio Registering the local variable table for each program Registering the local variable table for each function block and function 	Global Variable Table Editor Local Variable Table Editor	<i>Sysmac Studio Version 1 Operation Manual (Cat. No. W504)</i> <i>NJ/NX-series CPU Unit Software User's Manual (Cat. No. W501)</i>
2) Writing Algorithms for POUs	Writing the algorithms for the POUs (programs, function blocks, and functions) in the required languages	Programming Editor	<i>NJ/NX-series CPU Unit Software User's Manual (Cat. No. W501)</i> <i>NJ/NX-series Instructions Reference Manua (Cat. No. W502)</i> <i>NJ/NX-series Motion Control Instructions Reference Manual (Cat. No. W508)</i>
3) Setting the Tasks	Making task settings	Configurations and Setup – Task Settings	<i>NJ/NX-series CPU Unit Software User's Manual (Cat. No. W501)</i>



Step 2-4 Offline Debugging	Checking the algorithms and task execution times on the Simulator (virtual controller)		<i>NJ/NX-series CPU Unit Software User's Manual (Cat. No. W501)</i>
---------------------------------------	--	--	---



STEP3. Mounting and Setting Hardware

Step	Description	Reference
1) Mounting	<ul style="list-style-type: none"> Connecting adjacent Units Mounting to DIN Track 	<i>5-3 Mounting Units on page 5-11</i>
2) Setting Hardware	<ul style="list-style-type: none"> Setting the node addresses of the EtherCAT slaves 	Operation manuals for the EtherCAT slaves



STEP4. Wiring

Step	Description	Reference
1) Connecting the Power Supply to the CPU Unit	<ul style="list-style-type: none"> Connecting the power supply and ground wires 	<i>Section 4 Designing the Power Supply System on page 4-1</i> <i>5-4 Wiring on page 5-42</i>
2) Connecting Ethernet Cable	<ul style="list-style-type: none"> Connecting the built-in EtherCAT port Connecting the built-in EtherNet/IP port 	<i>NJ/NX-series CPU Unit Built-in Ether-CAT Port User's Manual (Cat. No. W505)</i> <i>NJ/NX-series CPU Unit Built-in EtherNet/IP Port User's Manual (Cat. No. W506)</i>

3) Wiring I/O	<ul style="list-style-type: none"> • Wiring the built-in I/O • Wiring I/O for NX Units • Wiring an Option Board 	<p>5-4-9 <i>Wiring the built-in I/O</i> on page 5-63</p> <p>Manuals for the specific NX Units</p> <p>5-4-10 <i>Wiring the NX1W-CIF01 Serial Communications Option Board</i> on page 5-67</p> <p>5-4-12 <i>Wiring the Analog I/O Option Board</i> on page 5-75</p>
	<ul style="list-style-type: none"> • Wiring I/O to EtherCAT slaves 	<p>Operation manuals for the EtherCAT slaves</p> <p>5-4 <i>Wiring</i> on page 5-42</p>
4) Connecting the Computer That Runs the Sysmac Studio	<ul style="list-style-type: none"> • Connecting the built-in EtherNet/IP port 	<p><i>Sysmac Studio Version 1 Operation Manual (Cat. No. W504)</i></p>



STEP5. Checking Operation and Starting Operation on the Actual System

Step	Description	Sysmac Studio Operations	Reference
1) Online Connection to Sysmac Studio and Project Download	<p>Turn ON the power supply to the Controller and place the Sysmac Studio online. Then, download the project. *1</p> <p>Perform this step before you create the slave configuration or NX Unit configuration from the mounted Units in step 2-1.</p>	<p>Controller – Communications Setup – Controller – Synchronization</p>	<p><i>NJ/NX-series CPU Unit Software User's Manual (Cat. No. W501)</i></p>



2) Clock Data Setting	<p>Set the clock data with the clock function when the battery is mounted.</p>	<p>Controller – Controller Clock</p>	<p><i>NJ/NX-series CPU Unit Software User's Manual (Cat. No. W501)</i></p>
------------------------------	--	---	--



3) Operation Check on Controller	<ol style="list-style-type: none"> 1. Check the wiring by using forced refreshing of real I/O from the I/O Map or Watch Tab Page. 2. For motion control, use the MC Test Run operations in PROGRAM mode to check the wiring. Then check the motor rotation directions for jogging, travel distances for relative positioning (e.g., for electronic gear settings), and homing operation. 3. Change the Controller to RUN mode and check the operation of the user program. 	<p>---</p>	<p><i>NJ/NX-series CPU Unit Software User's Manual (Cat. No. W501)</i></p>
---	---	------------	--



4) Actual Controller Operation	<p>Start actual operation.</p>	<p>---</p>	<p>---</p>
---------------------------------------	--------------------------------	------------	------------

*1. Use the Synchronize Menu of the Sysmac Studio to download the project.

2

System Configuration

This section describes the basic system configuration used for NX-series NX1P2 Controllers.

2-1	Basic System Configuration	2-2
2-1-1	EtherCAT Network Configuration	2-3
2-1-2	NX Unit Configuration	2-4
2-2	Connecting to the Sysmac Studio	2-7
2-3	Network Configuration.....	2-8

2-1 Basic System Configuration

An NX-series Controller NX1P2 supports the following two types of configurations.

- Basic Configuration

The basic configurations include the CPU Unit and the Configuration Units that are controlled directly by the CPU Unit. There are two basic configurations.

- a) EtherCAT network configuration
- b) NX Unit configuration

- Other Network Configurations

These are the configurations of the systems that are connected to the CPU Unit's built-in EtherNet/IP ports and Communications Units.

Basic Controller Configuration

- **EtherCAT Network Configuration**

With an NX-series CPU Unit, you can use an EtherCAT network as a basic system.

With the EtherCAT network system of the NX-series CPU Unit, the period for sequence processing and motion processing in the CPU Unit is the same as the EtherCAT communications period.

This enables high-precision sequence control and motion control with a constant period and little fluctuation.

For information on EtherCAT, refer to the *NJ/NX-series CPU Unit Built-in EtherCAT Port User's Manual* (Cat. No. W505).

- **NX Unit Configuration**

The CPU Rack consists of the following items.

- NX1P2 CPU Unit
- NX Unit NX-□□□□□□□□
- End Cover NX-END02

Up to eight NX Units can be connected.

By using the NX Units that support synchronous I/O refreshing, all I/O refreshing is synchronized with the task period of the primary periodic task of the CPU Unit.

This enables high-precision synchronized control with a stable fixed period.

2-1-1 EtherCAT Network Configuration

The EtherCAT network configuration consists of an NX-series NX1P2 CPU Unit, an End Cover, and the EtherCAT slaves.

You use the built-in EtherCAT port on the NX-series NX1P2 CPU Unit to connect EtherCAT slaves.

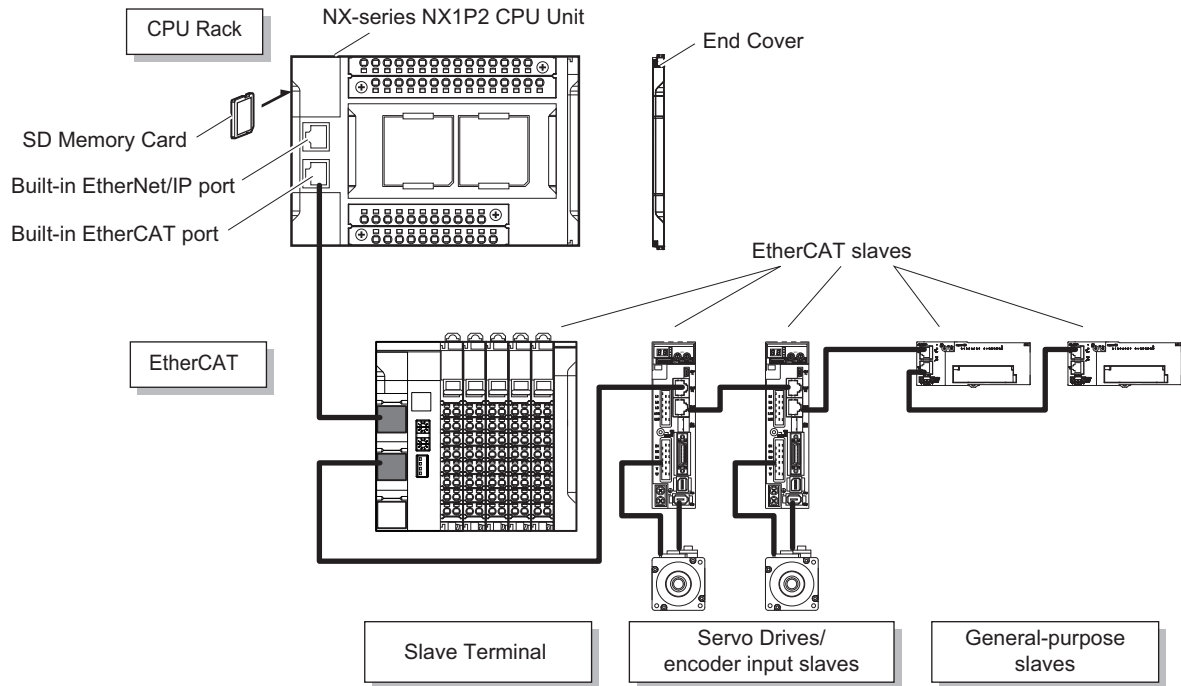

For information on the system configuration of an EtherCAT network, refer to the *NJ/NX-series CPU Unit Built-in EtherCAT Port User's Manual* (Cat. No. W505).

Refer to *2-1-2 NX Unit Configuration* on page 2-4 for information on the CPU Unit and End Cover.

2-1-2 NX Unit Configuration

The following shows the configuration of NX Units.

CPU Rack

The CPU Rack consists of an NX-series NX1P2 CPU Unit, NX Units, and an End Cover. Up to eight NX Units can be connected.

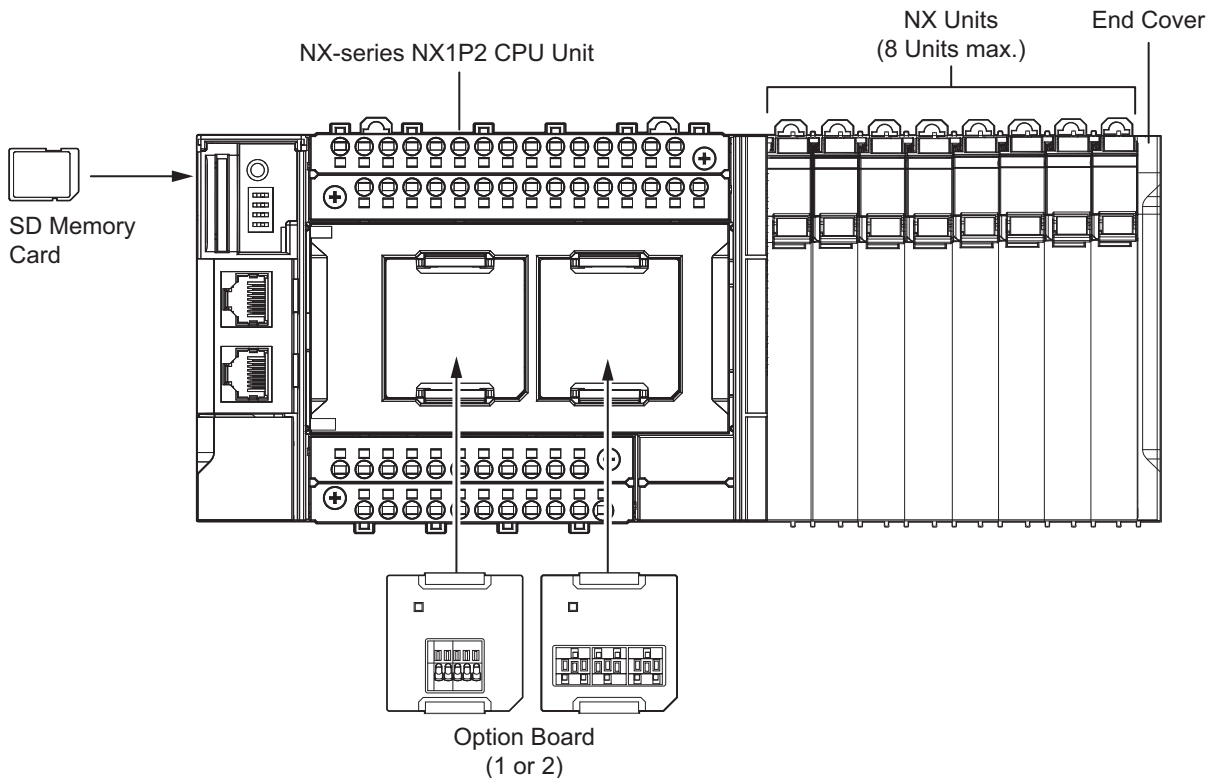

Series	Configuration	Remarks	
NX-series	NX-series NX1P2 CPU Unit	One required for every CPU Rack.	
	End Cover	Must be connected to the right end of the CPU Rack. One End Cover is provided with the CPU Unit.	
	NX Unit	Digital I/O Unit	Up to eight Units can be mounted on each CPU Rack. Refer to <i>A-4 Support Functions of the CPU Units and Restrictions on the NX Units</i> on page A-9 for information such as restrictions on the NX Units. For information on the most recent lineup of NX Units, refer to NX-series catalogs or OMRON websites, or ask your OMRON representative.
		Analog I/O Unit	
		System Unit	
		Position Interface Unit	
		Communications Interface Unit	
Load Cell Input Unit			
Option Board	Serial Communications Option Board	One or two Option Boards can be connected to the CPU Unit.	
	Analog I/O Option Board		
NJ/NX-series	SD Memory Card	Install as required.	

Configuration Units

● NX-series NX1P2 CPU Unit

The Unit that serves as the center of control for a Machine Automation Controller. It executes tasks, refreshes I/O for other Units and slaves, etc. In the NX-series, this type of Units is called NX1P2 CPU Unit.

Refer to *3-1 CPU Units* on page 3-2 for the models and specifications of individual NX-series NX1P2 CPU Unit.

● SD Memory Card

With the NX-series NX1P2 CPU Unit, various data can be saved, backed up, restored, and compared using the SD Memory Card.

Refer to *3-2 SD Memory Cards* on page 3-21 for the models and specifications of individual SD Memory Cards.

● NX Unit

The NX Units perform I/O processing with connected external devices. These Units are NX-series NX-□□□□□□ Units.

Up to eight NX Units can be connected to the CPU Unit.

Refer to *A-4 Support Functions of the CPU Units and Restrictions on the NX Units* on page A-9 for information such as restrictions on the NX Units.



Precautions for Correct Use

You cannot mount NX-series Safety Control Units on the CPU Unit and use them. Use NX-series Safety Control Units as a subsystem on EtherCAT.

● End Cover

A cover to protect the NX Unit and CPU Unit. This is provided with the CPU Unit. The model number is NX-END02.

● Option Board

The Option Boards are used to add the serial communications function or analog I/O function to the CPU Unit.

The Option Boards are mounted to the option board slot on the CPU Unit. The number of Option Boards that can be mounted to the CPU Unit depends on the number of slots on the CPU Unit.

Refer to *1-2 Specifications* on page 1-9 for the number of the option board slots on the CPU Unit.

Refer to *3-3 Serial Communications Option Board* on page 3-22 or *3-4 Analog I/O Option Board* on page 3-26 for the models and specifications of the Option Boards.

● Recommended Communications Cables for EtherCAT and EtherNet/IP

EtherCAT communications are performed in accordance with the 100BASE-TX standard. Refer to the *NJ/NX-series CPU Unit Built-in EtherCAT Port User's Manual* (Cat. No. W505) for recommended cables.

EtherNet/IP communications are performed in accordance with the 100BASE-TX or 10BASE-T standard. Refer to the *NJ/NX-series CPU Unit Built-in EtherNet/IP Port User's Manual* (Cat. No. W506) for recommended cables.

2-2 Connecting to the Sysmac Studio

Connect the NX-series NX1P2 CPU Unit and the Sysmac Studio through EtherNet/IP.
Refer to *3-7-2 Connection* on page 3-33 for information on how to make the connection between the NX-series NX1P2 CPU Unit and the Sysmac Studio.

2-3 Network Configuration

You can make networks in the following layers with an NJ/NX-series Controller.

For details on communications networks that you can connect to, refer to the *NJ/NX-series CPU Unit Software User's Manual (Cat. No. W501)*.

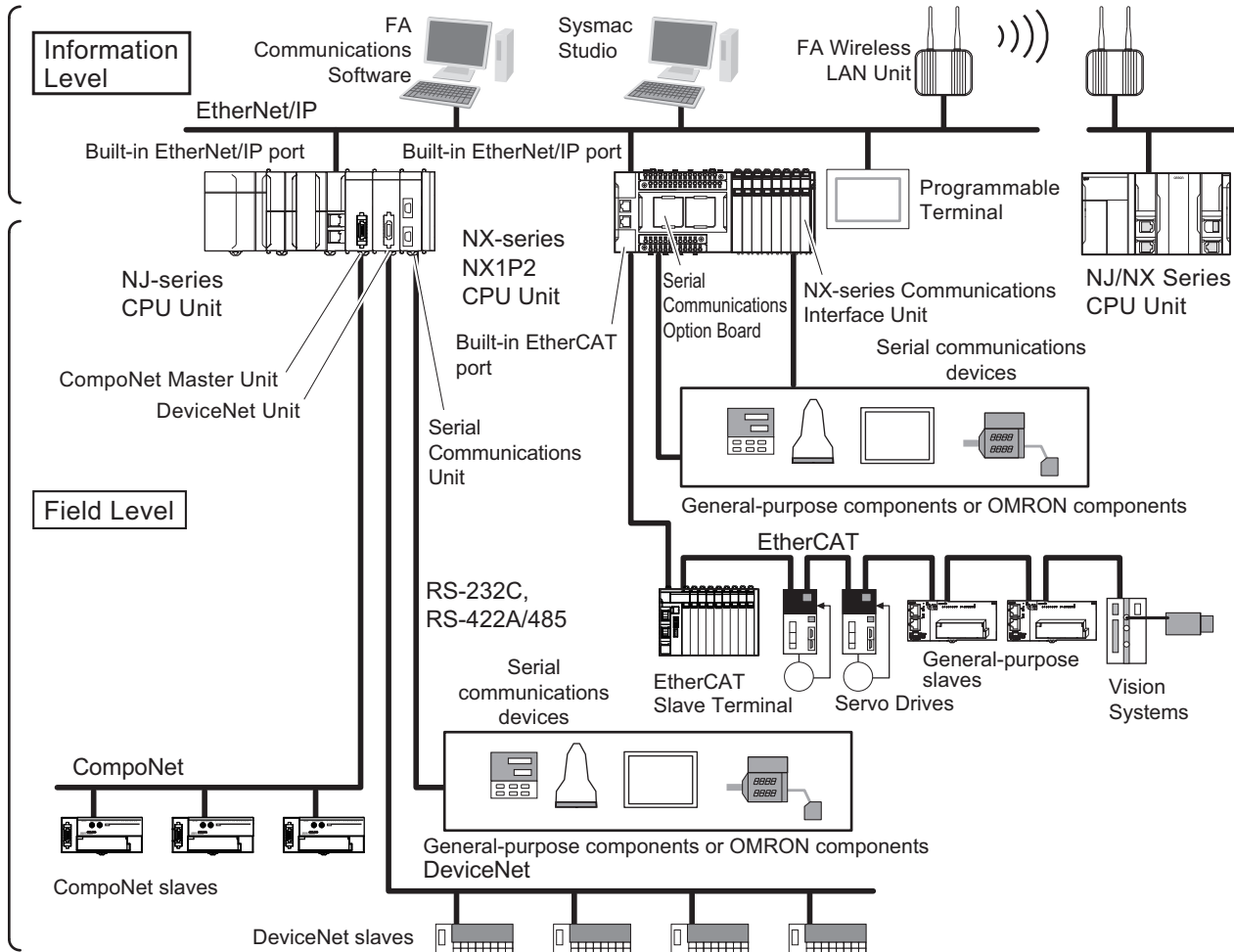

Connection		Connection method
Sysmac Studio		Use USB or the built-in EtherNet/IP port. For NX1P2 CPU Unit, only the built-in EtherNet/IP ports can be used.
Between Controllers	NJ/NX-series Controller or CJ-series PLC	Use the built-in EtherNet/IP port or a port on an EtherNet/IP Unit.* ¹
Devices	Servo Drives, general-purpose slaves and Vision Systems	Use the built-in EtherCAT port.
	Ethernet communications devices	Use the built-in EtherNet/IP port or a port on an EtherNet/IP Unit.* ¹
	Serial communications devices	Mount the following Units and use RS-232C port or RS-422A/485 ports. <ul style="list-style-type: none"> • CJ-series Serial Communications Unit*² • Serial Communications Option Board*³ • NX-series Communications Interface Unit*³
	DeviceNet slaves	Mount a CJ-series DeviceNet Unit* ² and use DeviceNet.
	CompoNet slaves	Mount a CJ-series CompoNet Master Unit* ² and use CompoNet.
Programmable Terminals		Use the built-in EtherNet/IP port or a port on an EtherNet/IP Unit.* ¹
Servers	Connections to BOOTP server, DNS server, or NTP server	Use the built-in EtherNet/IP port or a port on an EtherNet/IP Unit.* ¹

- *1. Use a CJ-series EtherNet/IP Unit with a unit version of 2.1 or later.
Also, mount the EtherNet/IP Unit to an NJ-series CPU Unit with unit version 1.01 or later, and use Sysmac Studio version 1.02 or higher.
Refer to the *NJ/NX-series CPU Unit Software User's Manual (Cat. No. W501)* for information on version upgrades.
- *2. Mount to an NJ-series CPU Unit.
- *3. Mount the Unit to the NX-series NX1P2 CPU Unit.

3

Configuration Units

This section describes configuration devices in the NX-series NX1P2 Controller configuration.

3-1	CPU Units	3-2
3-1-1	Models and Specifications	3-2
3-1-2	Part Names and Functions	3-5
3-1-3	Operation Status Indicators	3-7
3-1-4	Terminal Blocks.....	3-12
3-1-5	Battery	3-18
3-1-6	ID Information Indication.....	3-20
3-2	SD Memory Cards	3-21
3-2-1	Models and Specifications	3-21
3-2-2	Purpose	3-21
3-3	Serial Communications Option Board	3-22
3-3-1	Models and Specifications	3-22
3-3-2	Purpose	3-23
3-3-3	Part Names and Functions	3-23
3-4	Analog I/O Option Board	3-26
3-4-1	Models and Specifications	3-26
3-4-2	Purpose	3-27
3-4-3	Part Names and Functions	3-27
3-5	Power Supply-related Units	3-31
3-6	NX Units	3-32
3-7	Sysmac Studio	3-33
3-7-1	Model Numbers	3-33
3-7-2	Connection.....	3-33

3-1 CPU Units

This section describes the models and specifications of the CPU Units as well as the names and functions of the parts.

3-1-1 Models and Specifications

This section describes the outline of the CPU Unit specifications. The electrical and mechanical specifications of the CPU Unit are also given. Refer to *1-2 Specifications* on page 1-9 for information on other main specifications.

Models and Outline of Specifications

The models and outline of specifications are given below.

Model	Program capacity	Memory capacity for variables	Maximum number of controlled axes	Built-in I/O				
				Total number of I/O points	Number of input points	Number of output points		
NX1P2-1140DT	1.5 MB	32 kB (Retained during power interruptions) or 2 MB (Not retained during power interruptions)	12 axes	40 points	24 points	16 points, NPN transistor		
NX1P2-1140DT1						16 points, PNP transistor ^{*1}		
NX1P2-1040DT			10 axes			16 points, NPN transistor		
NX1P2-1040DT1						16 points, PNP transistor ^{*1}		
NX1P2-9024DT			4 axes			24 points	14 points	10 points, NPN transistor
NX1P2-9024DT1								10 points, PNP transistor ^{*1}
NX1P2-9B40DT	1.0 MB		2 axes	40 points	24 points	16 points, NPN transistor		
NX1P2-9B40DT1						16 points, PNP transistor ^{*1}		
NX1P2-9B24DT			24 points	14 points	10 points, NPN transistor			
NX1P2-9B24DT1					10 points, PNP transistor ^{*1}			

*1. With short-circuit protection

Electrical and Mechanical Specifications

The electrical and mechanical specifications are given below.

Item		Specification	
Model		NX1P2-□□40DT□	NX1P2-9□24DT□
Enclosure		Mounted in a panel	
Dimensions (mm)*1		154 × 100 × 71 mm (W×H×D)	130 × 100 × 71 mm (W×H×D)
Weight*2		NX1P2-□□40DT: 650 g NX1P2-□□40DT1: 660 g	NX1P2-9□24DT: 590 g NX1P2-9□24DT1: 590 g
Unit power supply	Power supply voltage	24 VDC (20.4 to 28.8 VDC)	
	Unit power consumption*3	NX1P2-□□40DT: 7.05 W NX1P2-□□40DT1: 6.85 W	NX1P2-9□24DT: 6.70 W NX1P2-9□24DT1: 6.40 W
	Inrush current*4	For cold start at room temperature: 10 A max./0.1 ms max. and 2.5 A max./150 ms max.	
	Current capacity of power supply terminal*5	4 A max.	
	Isolation method	No isolation: between the Unit power supply terminal and internal circuit	
Power supply to the NX Unit power supply	NX Unit power supply capacity	10 W max.	
	NX Unit power supply efficiency	80%	
	Isolation method	No isolation: between the Unit power supply terminal and NX Unit power supply	
I/O power supply to NX Units		Not provided*6	
External connection terminals	Communications connector	RJ45 for EtherNet/IP Communications × 1 RJ45 for EtherCAT Communications × 1	
	Screwless clamping terminal block	For Unit power supply input, grounding, and input signal: 1 (Removable) For output signal: 1 (Removable)	
	Output terminal (service supply)	Not provided	
	RUN output terminal	Not provided	
	NX bus connector	8 NX Units can be connected	
	Option board slot	2	1

*1. Includes the End Cover, and does not include projecting parts.

*2. Includes the End Cover. The weight of the End Cover is 82 g.

*3. Includes the SD Memory Card and Option Board. The NX Unit power consumption to NX Units is not included.

*4. The inrush current may vary depending on the operating condition and other conditions. Therefore, select fuses, breakers, and external power supply devices that have enough margin in characteristic and capacity, considering the condition under which the devices are used.

*5. The amount of current that can be passed constantly through the terminal. Do not exceed this current value when you use a through-wiring for the Unit power supply.

- *6. When the type of the I/O power supply to NX Units you use is the supply from NX bus, an Additional I/O Power Supply Unit is required. The maximum I/O power supply current from an Additional I/O Power Supply Unit is 4 A. Refer to 4-3 *Designing the I/O Power Supply System* on page 4-10 for details.

3-1-2 Part Names and Functions

The following two models have the different numbers of the option board slots and built-in I/O points, but the names and functions of their parts are the same. Refer to 3-1-1 Models and Specifications on page 3-2 for the CPU Unit models and specifications such as the number of built-in I/O points.

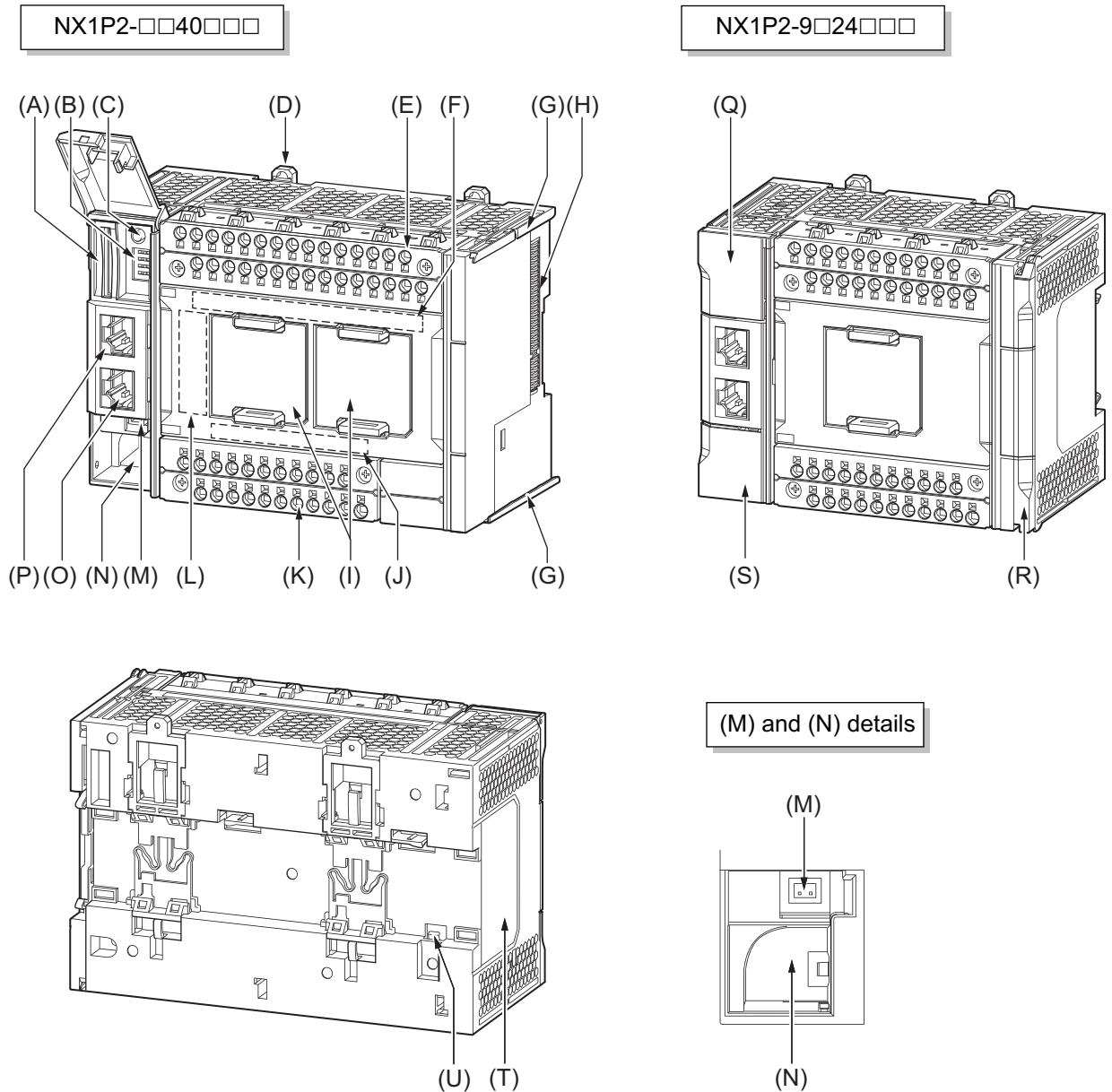

Letter	Name	Function
A	SD Memory Card connector	Connects the SD Memory Card to the CPU Unit.
B	DIP switch	Used in Safe Mode* ¹ or when backing up data* ² . Normally, turn OFF all of the pins.
C	SD Memory Card power supply switch	Turns OFF the power supply so that you can remove the SD Memory Card. <i>5-3-8 Installing and Removing the SD Memory Card</i> on page 5-27
D	DIN Track mounting hook	These hooks are used to mount the Unit to a DIN Track.

Letter	Name	Function
E	Input terminal block	This terminal block is used for wiring for the Unit power supply, grounding, and built-in input.
F	Input indicator	Shows the operation status of the built-in input. <i>Built-in I/O Operation Status Indicators</i> on page 3-11
G	Unit hookup guides	These guides are used to mount an NX Unit or End Cover.
H	NX bus connector	This connector is used to connect the CPU Unit to the NX Unit on the right of the CPU Unit.
I	Option board slot 1 (left) Option board slot 2 (right)	Remove the covers of the slots and mount Option Boards. For the models with 24 built-in I/O points, only one slot is provided. Keep the removed covers in a safe place.
J	Output indicator	Shows the operation status of the built-in output. <i>Built-in I/O Operation Status Indicators</i> on page 3-11
K	Output terminal block	This terminal block is used to wire the built-in output.
L	CPU Unit operation status indicator	Shows the operation status of the CPU Unit. <i>3-1-3 Operation Status Indicators</i> on page 3-7
M	Battery connector	Connector to mount the backup battery that is sold separately.
N	Battery slot	Used to mount the backup battery that is sold separately.
O	Built-in EtherCAT port (port 2)	Connects the built-in EtherCAT with an Ethernet cable.
P	Built-in EtherNet/IP port (port 1)	Connects the built-in EtherNet/IP with an Ethernet cable.
Q	SD Memory Card cover	Cover for the SD Memory Card and DIP switch. The cover swings upward.
R	End Cover	Cover to protect the CPU Unit and NX Units. One End Cover is provided with the CPU Unit.
S	Battery cover	Cover for the battery slot. Remove this cover when you mount/remove the battery.
T	ID information indication	Shows the ID information of the CPU Unit. <i>3-1-6 ID Information Indication</i> on page 3-20
U	DIN Track contact plate	This plate is connected internally to the functional ground terminal on the terminal block.

*1. To use Safe Mode, set the DIP switch as shown below and then turn ON the power supply to the Controller.

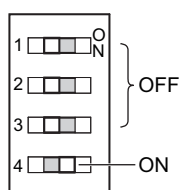

If the power supply to the Controller is turned ON with the CPU Unit in Safe Mode, the CPU Unit will start in PROGRAM mode. Use the Safe Mode if you do not want to execute the user program when the power supply is turned ON or if it is difficult to connect the Sysmac Studio.

For information on Safe Mode, refer to the *NJ-series Troubleshooting Manual (Cat. No. W503)*.

*2. Refer to the *NJ-series CPU Unit Software User's Manual (Cat. No. W501)* for details on backing up data.

3-1-3 Operation Status Indicators

CPU Unit Status Indicators

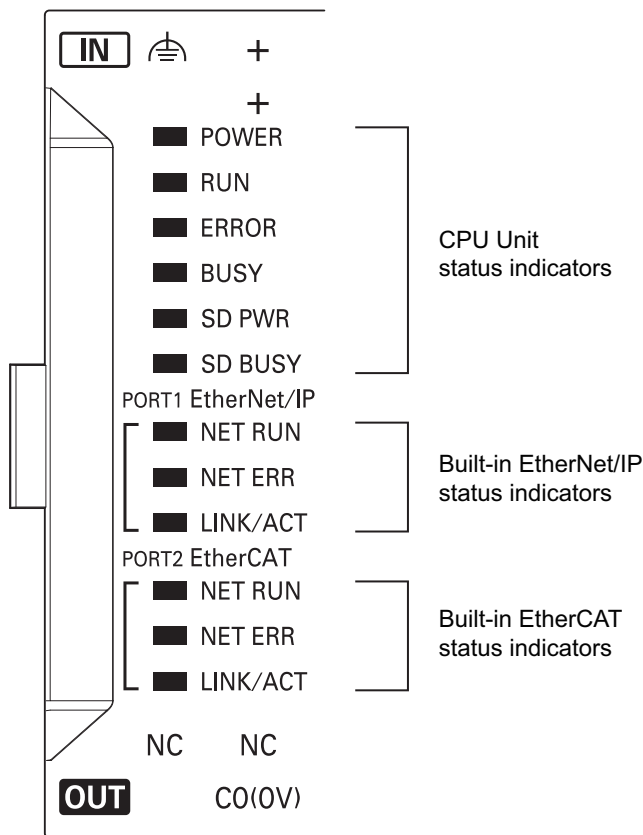

There are the indicators to show the operation status of CPU Unit in the center of the front side of the CPU Unit.

















● CPU Unit Status Indicators

These indicators show the main operation status of the CPU Unit.

The following table describes these indicators.

Indicator	Color	Status	Meaning	
POWER	Green		Lit.	Power is ON.
			Not lit.	Power is not ON. Or, the power supply voltage is outside the allowable voltage range.

Indicator	Color	Status	Meaning
RUN	Green		Lit. The CPU Unit is in normal operation in RUN mode. (The user program is in execution.)
			Flashing at 2-s intervals, then flashing at 0.5-s intervals. The CPU Unit is starting (entering RUN mode or PROGRAM mode at startup).
			Flashing at 2-s intervals continues for 30 seconds or longer. System initialization error occurs.
			Not lit. Operation is stopped in PROGRAM mode, when a CPU Unit reset is in progress, or when any of the following errors occurs. <ul style="list-style-type: none"> Controller error in the major fault level CPU error (WDT error)
ERROR	Red		Lit. Self-diagnosis found one of the following errors. <ul style="list-style-type: none"> Controller error in the major fault level CPU error
			Flashing at 1-s intervals. Self-diagnosis found one of the following errors. <ul style="list-style-type: none"> Controller error in the partial fault level (an error in which all control of a Function Module is disabled) Controller error in the minor fault level (an error in which partial control of a Function Module is disabled) CPU Unit operation will continue for either of these errors. Operation will stop for the Function Module in which a Controller error in the partial fault level occurred. Operation will continue for the Function Module in which a Controller error in the minor fault level occurred.
			Not lit. The CPU Unit is in normal operation, a CPU reset is in progress, or monitored information occurred (CPU Unit operation will continue.).
BUSY	Yellow		Flashing Built-in non-volatile memory access in progress.
			Not lit. Other than the above.
SD PWR	Green		Lit. Power is being supplied to the SD Memory Card and the SD Memory Card can be used.
			Flashing A backup, restore or verification operation is in progress.*1
			Not lit. The power supply for the SD Memory Card is stopped, an SD Memory Card is not mounted, or the file format of the mounted SD Memory Card is not supported.
SD BUSY	Yellow		Flashing SD Memory Card access in progress.
			Not lit. SD Memory Card access not in progress.

*1. Refer to the *NJ/NX-series CPU Unit Software User's Manual (Cat. No. W501)* for details on backing up data.



Precautions for Safe Use









- Never turn OFF the power supply to the Controller when the BUSY indicator is flashing. While the BUSY indicator is lit, the user program and settings in the CPU Unit are being backed up in the built-in non-volatile memory. The data will not be backed up if the power supply is turned OFF. Also, a major fault level Controller error will occur the next time you start operation, and operation will stop.
 - Do not turn OFF the power supply or remove the SD Memory Card while SD Memory Card access is in progress (i.e., while the SD BUSY indicator flashes). Data may become corrupted, and the Controller will not operate correctly if it uses corrupted data. To remove the SD Memory Card from the CPU Unit while the power supply is ON, press the SD Memory Card power supply switch and wait for the SD BUSY indicator and SD PWR indicator to turn OFF before you remove the SD Memory Card.
-

You can check the operation status of the CPU Unit with the CPU Unit status indicators (POWER, RUN, and ERROR indicators).

Refer to the *NJ/NX-series Troubleshooting Manual (Cat. No. W503)* for the procedures to check the operation status of the CPU Unit.









● Built-in EtherNet/IP (Port 1) Status Indicators

These indicators show the operation status of the built-in EtherNet/IP port of the CPU Unit.

Indicator	Color	Status	Meaning
NET RUN	Green	 Not lit.	You cannot perform Ethernet communications. <ul style="list-style-type: none"> The power supply is OFF or the CPU Unit was reset. A MAC address error or communications Controller error occurred.
		 Flashing	Ethernet communications are in progress. <ul style="list-style-type: none"> Tag data link connection establishment in progress. IP address acquisition with BOOTP in progress.
		 Lit.	Normal startup status.
NET ERR	Red	 Not lit.	There are no Ethernet communications errors. <ul style="list-style-type: none"> The power supply is OFF or the CPU Unit was reset.
		 Flashing	An error for which the user can recover operation occurred. <ul style="list-style-type: none"> An error occurred in TCP/IP communications or CIP communications. FTP server setting error, NTP server setting error, etc. Tag data link setting error, tag data link verification error, etc.
		 Lit.	An error for which the user cannot recover operation occurred. <ul style="list-style-type: none"> A MAC address error or communications Controller error occurred.
LINK/ACT	Yellow	 Not lit.	A link was not established. <ul style="list-style-type: none"> The cable is not connected. The power supply is OFF or the CPU Unit was reset.
		 Flashing	The link is established, and data communications are in progress.
		 Lit.	The link was established.

● Built-in EtherCAT (Port 2) Status Indicators

These indicators show the operation status of the built-in EtherCAT port of the CPU Unit.



Indicator	Color	Status	Meaning
NET RUN	Green	 Lit.	EtherCAT communications are in progress. <ul style="list-style-type: none"> Inputs and outputs for I/O data are in operation.
		 Flashing	EtherCAT communications are established. This indicator shows either of the following conditions. <ul style="list-style-type: none"> Only message communications are in operation. Only message communications and I/O data inputs are in operation.
		 Not lit.	EtherCAT communications are stopped. <ul style="list-style-type: none"> The power supply is OFF or the CPU Unit was reset. A MAC address error, communications Controller error, or other error occurred.
NET ERR	Red	 Lit.	A hardware error or unrecoverable error occurred, such as for exception processing.
		 Flashing	A recoverable error occurred.
		 Not lit.	There are no errors.
LINK/ACT	Yellow	 Lit.	A link is established.
		 Flashing	Data communications are in progress after establishing link. Flashes every time data is sent or received.
		 Not lit.	The link was not established.

Built-in I/O Operation Status Indicators

These indicators show the operation status of the built-in I/O of the CPU Unit.

COM	01	03	05	07
	00	02	04	06

The following example shows the status of the contact 01. The display of the I/O contact number lights or does not light.

Indicator	Color	Status	Description
Input indicator	Yellow		Lit. The input contact is ON.
		01	Not lit. The input contact is OFF.
Output indicator	Yellow		Lit. The output contact is ON.
		01	Not lit. The output contact is OFF.

3-1-4 Terminal Blocks

The terminal blocks on the CPU Unit are removable screwless clamping terminal blocks that allow you to easily connect and remove the wiring.

There are the input terminal block and output terminal block.

This section provides the part names and functions of the terminal blocks, the terminal arrangement of the input and output terminal blocks, and other information.

Terminal Block Part Names and Functions

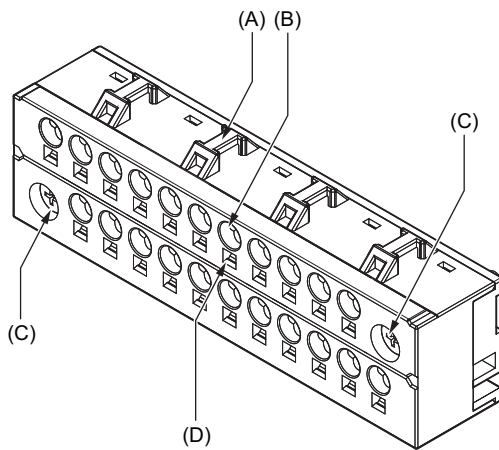

Letter	Name	Function
A	Hole for securing wires	Pass a cable tie through this hole for securing the wires.
B	Terminal hole	The wire is inserted into this hole.
C	Screw for securing	Screw for securing the terminal block on the CPU Unit.
D	Release hole	Insert a flat-blade screwdriver into this hole to connect and remove the wire.

Refer to *5-4-8 Wiring to the CPU Unit Terminal Block* on page 5-49 for the wiring procedure.

Input Terminal Block

● Terminal Arrangement

The description is given for each CPU Unit model.

a. NX1P2-□□40DT□

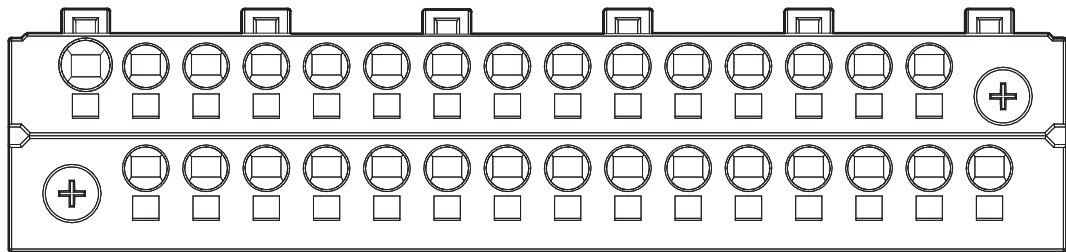

⏏	+	-	COM	01	03	05	07	09	11	13	15	17	19	21	
	+	-	00	02	04	06	08	10	12	14	16	18	20	22	23

Symbol	Terminal name	Description	Reference
⏏	Functional ground terminal	The functional ground terminal. Connect the ground wire to the terminal.	5-4-5 Grounding on page 5-44
+/-	Unit power supply terminals	These terminals are connected to the Unit power supply. The + terminals and - terminals are internally connected to each other.	5-4-1 Wiring the Unit Power Supply on page 5-43
COM	Common terminal	Common terminal for the input circuits	Input Specifications on page 3-14
00 to 15	Input terminals	General-purpose input A	
16 to 23	Input terminals	General-purpose input B	

b. NX1P2-9□24DT□

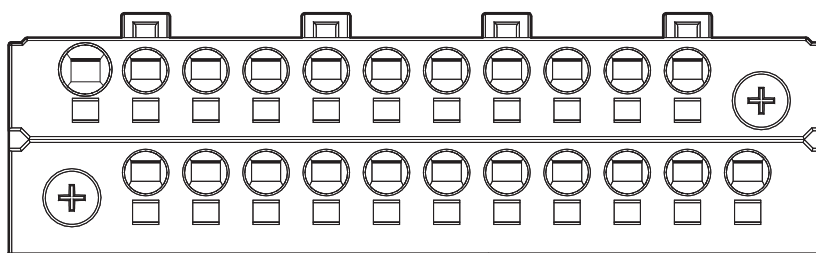

⏏	+	-	COM	01	03	05	07	09	11	13	
	+	-	00	02	04	06	08	10	12	NC	NC

Symbol	Terminal name	Description	Reference
⏏	Functional ground terminal	The functional ground terminal. Connect the ground wire to the terminal.	5-4-5 Grounding on page 5-44

Symbol	Terminal name	Description	Reference
+/-	Unit power supply terminals	These terminals are connected to the Unit power supply. The + terminals and - terminals are internally connected to each other.	5-4-1 <i>Wiring the Unit Power Supply</i> on page 5-43
COM	Common terminal	Common terminal for the input circuits	<i>Input Specifications</i> on page 3-14
00 to 13	Input terminals	General-purpose input A	
NC	NC	Do not connect anything.	---

● Input Specifications

The specifications depend on the input terminal numbers of the model.

Item	Specification	
	General-purpose input A	General-purpose input B
Input type		
Input terminal number	NX1P2-□□40DT□: 00 to 15 NX1P2-9□24DT□: 00 to 13	NX1P2-□□40DT□: 16 to 23 NX1P2-9□24DT□: None
Internal I/O common	For both NPN/PNP	
Input voltage	24 VDC (15 to 28.8 VDC)	
Connected sensor	Two-wire or three-wire sensors	
Input impedance	4.0 kΩ	4.3 kΩ
Input current	5.8 mA typical	5.3 mA typical
ON voltage	15 VDC min.	
OFF voltage/current	5 VDC max./1 mA max.	
ON response time*1	2.5 μs max.	1 ms max.
OFF response time*1	2.5 μs max.	1 ms max.
ON/OFF filter time*2	No filter, 0.25 ms, 0.5 ms, 1 ms (default), 2 ms, 4 ms, 8 ms, 16 ms, 32 ms, 64 ms, 128 ms, 256 ms	
Circuit configuration		

*1. These values are the fixed response time needed by the hardware. A value from 0 to 32 ms (default: 1 ms) that is set on the Support Software is added to these values.

*2. Set the filter time for every 4 points.



Precautions for Safe Use

Do not apply voltages that exceed the rated value.

NC	NC	00	02	04	06	08	NC	NC	NC	NC
	C0 (0V)	01	03	05	07	09	NC	NC	NC	NC

Symbol	Terminal name	Description	Reference
C0(0V)	Common terminal	Connected to the 0-V side of the I/O power supply.	<i>Output Specifications</i> on page 3-17
00 to 09	Output terminals	NPN (sinking) type output	
NC	NC	Do not connect anything.	---

d. NX1P2-9□24DT1

The appearance of the terminal block is the same as (a).

NC	C0 (+V)	00	02	04	06	08	NC	NC	NC	NC
	0V0	01	03	05	07	09	NC	NC	NC	NC

Symbol	Terminal name	Description	Reference
C0(+V)	Common terminal	Connected to the 24-V side of the I/O power supply.	<i>Output Specifications</i> on page 3-17
0V0	0 V terminal	Supplies 0 V for the internal circuits for driving.	
00 to 09	Output terminals	PNP (sourcing) type output with the load short-circuit protection function	
NC	NC	Do not connect anything.	---

● Output Specifications

The models of the CPU Units are divided according to the following two output types: the NPN (sinking) type and PNP (sourcing) type.

There is no difference in specifications between the models with different output terminal numbers.

Item	Specification	
	NX1P2-□□□□DT	NX1P2-□□□□DT1
Internal I/O common	NPN (sinking)	PNP (sourcing)
Maximum switching capacity	12 to 24 VDC (10.2 to 28.8 VDC), 300 mA per point	24 VDC (15 to 28.8 VDC), 300 mA per point
	NX1P2-□□40DT□: 1.8 A/common (3.6 A/Unit) NX1P2-9□24DT□: 2.4 A/common (2.4 A/Unit)	
Minimum switching capacity	12 to 24 VDC (10.2 to 28.8 VDC), 1 mA	24 VDC (15 to 28.8 VDC), 1 mA
Leakage current	0.1 mA max.	
Residual voltage	1.5 V max.	
ON response time	0.1 ms max.	0.5 ms max.
OFF response time	0.8 ms max.	1.0 ms max.
Current consumption from I/O power supply*1	---	NX1P2-□□40DT1: 40 mA/common NX1P2-9□24DT1: 50 mA/common
Load short-circuit protection	Not provided	Provided*2
Circuit configuration		

*1. The internally consumed current from I/O power supply. The current flows from the common terminal Cn (+V) to the 0Vn terminal. The current consumption of any external load is excluded.

*2. The load short-circuit protection is provided for each point of the PNP (sourcing) type output terminal. It protects the output circuits when a load short circuit occurs.



Precautions for Safe Use

Do not apply voltages or connect loads in excess of the maximum switching capacity.

3-1-5 Battery

The battery is not mounted when the product is shipped.

To turn OFF the power supply to the equipment for a certain period of time by using the clock data for programming, event logs, etc., you need a separately-sold battery to retain the clock data.

The following describes the purpose of the battery mounting, the battery model, and the battery-related error detection and clock data settings.

Purpose of the Battery Mounting

The battery is used to retain the clock data while the power is not supplied to the CPU Unit. The clock data is retained by the built-in capacitor whether the battery is mounted or not, but the retention period depends on the continuous power-ON time of the CPU Unit, as shown below.

Continuous power-ON time of CPU Unit*1	Retention period during no power supply at an ambient temperature of 40°C
100 hours	Approx. 10 days
8 hour	Approx. 8 days
1 hour	Approx. 7 days

*1. This is equivalent to the time to charge a built-in capacitor in which no electric charge is accumulated.

When you use the clock data for programming, use a battery if you cannot ensure the continuous power-ON time shown above or the power-OFF time is longer than the above power-ON time.

The following data (other than the clock data) is retained in the built-in non-volatile memory, so they are not lost even if the battery and built-in capacitor are fully discharged.

- User program
- Set values
- Variables retained during power interruption
- Event logs

Battery Model

The table below shows the model and specifications of the battery that can be used.

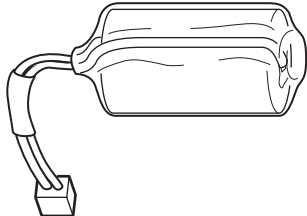
Model	Appearance	Specification
CJ1W-BAT01		Service life: 5 years For the battery lifetime, refer to <i>Battery Service Life and Replacement Period</i> on page 7-7. The clock information is retained during power interruptions.

Battery-related Error Detection and Clock Data Settings

Because the CPU Unit is shipped with the battery not mounted, the **Battery-related error detection** is set to **Do not use** by default.

The behavior of the CPU Unit when a battery-related error is detected depends on whether battery error detection is used or not used as shown in the table below.

When the battery is not mounted, you can set the **Battery-related error detection** to **Do not use** to suppress battery errors.

When the battery is mounted, however, you can set the **Battery-related error detection** to **Use** to detect battery errors.

Cause of error	What is affected	Behavior	
		When the Battery-related error detection is set to Do not use	When the Battery-related error detection is set to Use
One of the following was detected at power ON. <ul style="list-style-type: none"> Built-in capacitor discharged Battery not mounted Mounted battery discharged 	Clock data	<ul style="list-style-type: none"> In case of clock oscillator stopping Time measurement starts from January 1st, 1970. In case of low battery voltage Time measurement continues. 	
	Error detection	No error is detected.	The following error is detected. <ul style="list-style-type: none"> Low Battery Voltage Real-Time Clock Stopped
One of the following was detected after power ON. <ul style="list-style-type: none"> Battery was removed Mounted battery discharged 	Clock data	Time measurement continues.	
	Error detection	No error is detected.	The following error is detected. <ul style="list-style-type: none"> Low Battery Voltage

When you mount the battery, set the **Battery-related error detection** to **Use**.

The measurement of clock data starts from January 1st, 1970 if the clock oscillator stops. If this occurs, readjust the CPU Unit's clock data to the current time.

In order to use the clock data for programming, you need to use system-defined variables to read the presence or absence of the Low Battery Voltage and Real-Time Clock Stopped errors and confirm that the clock data is normal.

Refer to the *Sysmac Studio Version 1 Operation Manual (Cat. No. W504)* for battery-related error detection and clock data settings.

3-1-6 ID Information Indication

You can check the followings in the ID information indications on the left side of the CPU Unit.

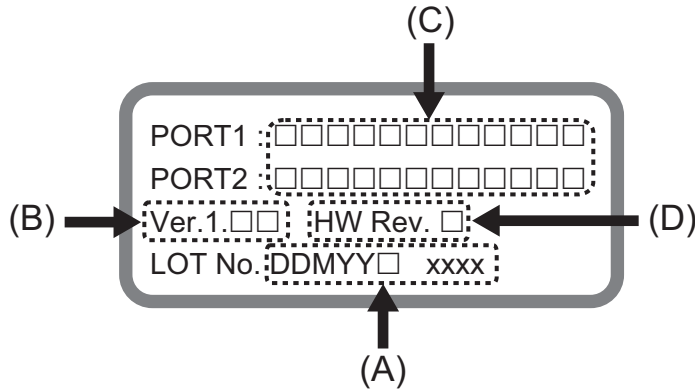

Letter	Name	Function
A	Lot number and serial number	Shows the lot number and the serial number of the CPU Unit. DDMY: Lot number, □: For use by OMRON, SSSS: Serial number M is 1 to 9 for January to September, X for October, Y for November, and Z for December.
B	Unit version	Shows the unit version of the CPU Unit.
C	MAC addresses	Shows the MAC addresses of the built-in EtherNet/IP port (port 1) and built-in EtherCAT port (port 2) on the CPU Unit.
D	Hardware revision	Shows the hardware revision of the CPU Unit. *1

*1. The hardware revision is not displayed for the Unit that the hardware revision is in blank.

3-2 SD Memory Cards

This section describes the models, specifications, and application of the SD Memory Cards.

3-2-1 Models and Specifications

SD cards and SDHC cards are supported, but use one of the following OMRON Cards. OMRON is not responsible for the operation, performance, or write life of any other SD or SDHC card.

Model	Card type	Capacity[GB]	Format	Number of overwrites	Weight
HMC-SD291	SD Card	2	FAT16	100,000*1	2 g max.
HMC-SD491	SDHC Card	4	FAT32		
HMC-SD1A1*2		16			

*1. This number represents the number of overwrites when the SD Memory Card is used on an NX-series CPU Unit. When the SD Memory Card is used on other equipment such as a personal computer, the number of overwrites may be reduced.

*2. This can be used for a CPU Unit with unit version 1.21 or later.



Additional Information

Write Protection Key

You will not be able to write to the SD Memory Card if the key is set to the LOCK position. Use this setting to prevent overwriting.

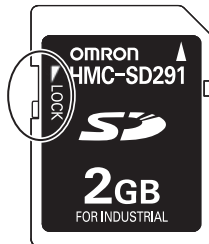

3-2-2 Purpose

You can use the SD Memory Card for the following applications.

- Read and write files in the SD Memory Card with instructions.
- Read and write files in the SD Memory Card from an FTP client on EtherNet/IP.
- Back up, restore, and verify data in the Controller.
- Transfer data from the SD Memory Card to the Controller when the power is turned ON.

Refer to the *NJ/NX-series CPU Unit Software User's Manual (Cat. No. W501)* for details on the functions for SD Memory Cards.

3-3 Serial Communications Option Board

3-3-1 Models and Specifications

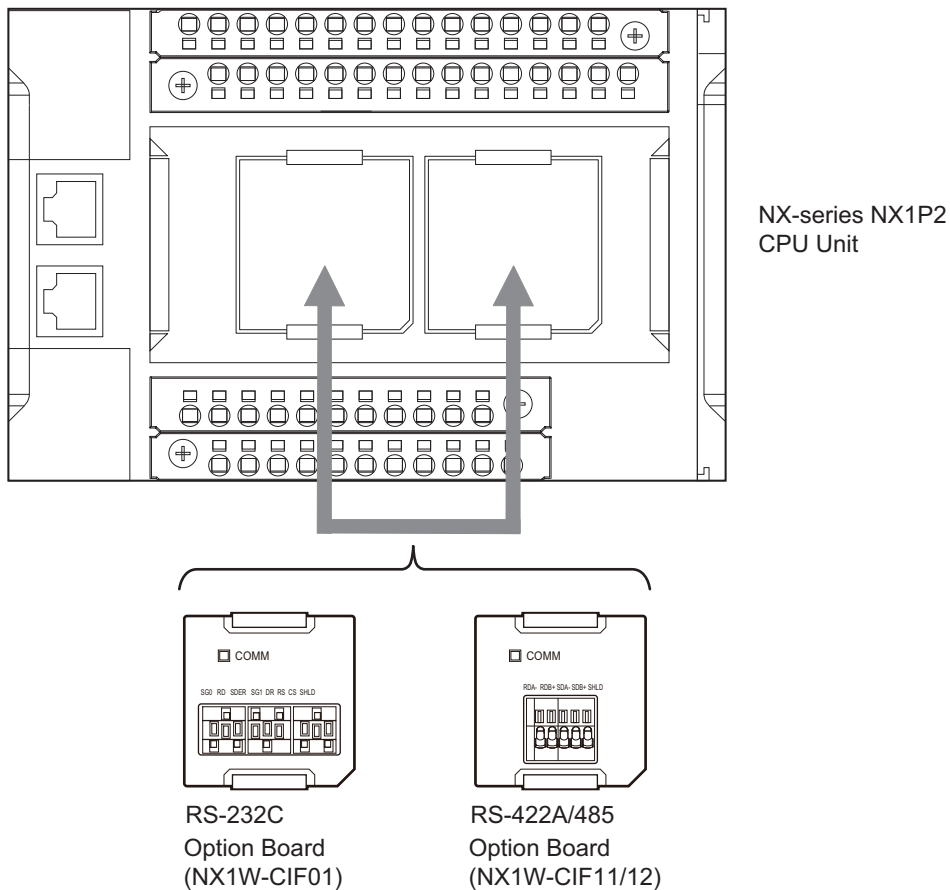

This section explains the specifications that are common to all types of Serial Communications Option Boards.

Refer to 3-3-3 *Part Names and Functions* on page 3-23 for the specifications that differ depending on the model.

Item	Specification		
Model	NX1W-CIF01	NX1W-CIF11	NX1W-CIF12
Communications port	One RS-232C port	One RS-422A/485 port	One RS-422A/485 port (isolated)
Communications method	Half-duplex		
Synchronization method	Start-stop synchronization		
Baud rate	1.2/2.4/4.8/9.6/19.2/38.4/57.6/115.2 kbps		
Transmission distance	15 m	50 m	500 m
Supported protocol	Host link, Modbus-RTU master, and no-protocol		
Connection type	Screwless clamping terminal block (9 terminals)	Screwless clamping terminal block (5 terminals)	
Applicable wire size	AWG28 to 20	AWG24 to 20	
Dimensions (mm)*1	35.9 × 35.9 × 13.5 (W×H×D)		
Weight	16 g	13 g	14 g

Item	Specification
Power consumption	Included in the CPU Unit power consumption. The Option Board power consumption is included in the definition of the CPU Unit power consumption.
Isolation method	No isolation Isolation* ²

*1. Projecting parts such as a terminal block is not included. When the Option Board is mounted to the CPU Unit, it protrudes through the CPU Unit surface. The details are explained in *5-3-13 Assembled Appearance and Dimensions* on page 5-38.

*2. The terminals are isolated from the internal circuits of the CPU Unit.

3-3-2 Purpose

A Serial Communications Option Board is used to connect the general-purpose components with a serial interface to the CPU Unit in order to perform data I/O processing. The general-purpose components with a serial interface includes a bar code reader, Temperature Controller and PT.

An RS-232C and RS422A/485 ports are supported, and up to two ports can be built in the CPU Unit.

The supported communications protocols are the host link, Modbus-RTU master, and no-protocol.

Refer to the *NX-series NX1P2 CPU Unit Built-in I/O and Option Board User's Manual* (Cat. No. W579) for details on how to use the Option Boards.

3-3-3 Part Names and Functions

RS-232C Option Board (NX1W-CIF01)

Communications status indicator

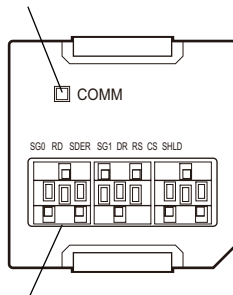

RS232C terminal block

● Communications Status Indicator

Indicator	Color	Status	Description
COMM	Yellow		Lit. Communications are being performed.
			Not lit. Communications are not performed.

● **RS-232C Terminal Block**

	Abbrevia- tion	Signal name	I/O
	SG0	Signal grounding	---
	RD	Receive data	Input
	SD	Send data	Output
	ER	Data terminal ready	Output
	SG1	Signal grounding	---
	DR	Data set ready	Input
	RS	Send request	Output
	CS	Data can be sent	Input
	SHLD	Shield	---

As the Option Board does not have a 5 V power supply terminal, it cannot be connected to external converters such as an CJ1W-CIF11 and NT-AL001, or an NV3W-M□20L Programmable Terminal. The terminal block is not removable.

RS-422A/485 Option Board (NX1W-CIF11/NX1W-CIF12)

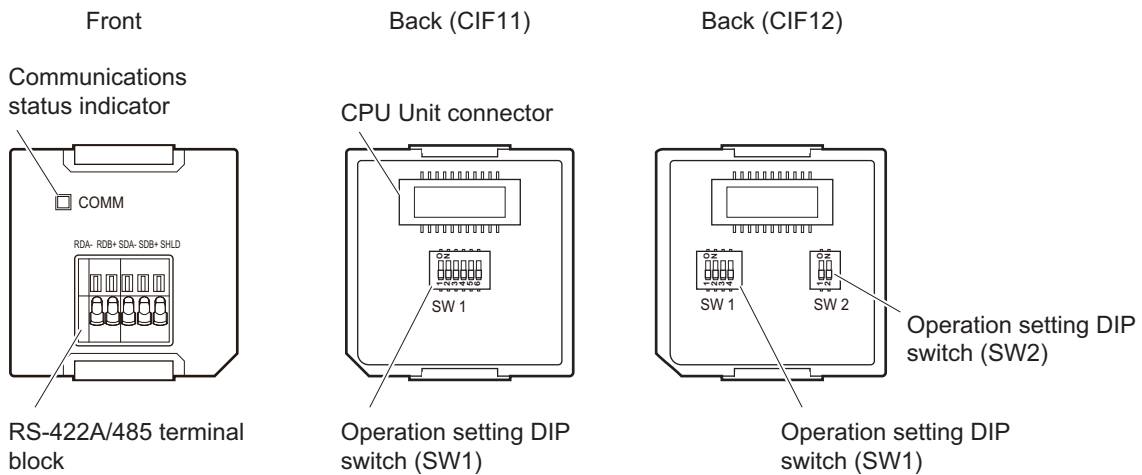

● **Communications Status Indicator**

Indicator	Color	Status	Description
COMM	Yellow		Lit. Communications are being performed.
			Not lit. Communications are not performed.

● **Operation Setting DIP Switch**

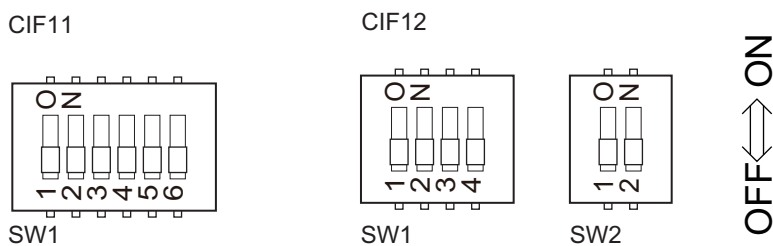

CIF11		CIF12		Setting				
SW	No.	SW	No.					
SW1	1	SW1	1	ON	Terminating resistance provided	Select whether a terminating resistance is provided or not. The value of a terminating resistance is approximately 220 Ω.		
				OFF	Terminating resistance not provided			
	2		2	ON	Two-wire type	Select the two-wire or four-wire type. To set the two-wire type, turn ON both No. 2 and No. 3 pins. To set the four-wire type, turn OFF both No. 2 and No. 3 pins.		
				OFF	Four-wire type			
	3		3	ON	Two-wire type			
				OFF	Four-wire type			
	4		4	---	---	Not used.		
	5		1	SW2	1	ON	RS control enabled	Select whether to enable the RS control for receive data.
						OFF	RS control disabled (continuous reception)	To prohibit the echo back, enable the RS control (ON).
			2		2	ON	RS control enabled	Select whether to enable the RS control for send data.
OFF		RS control disabled (continuous transmission)				For a four-wire, 1-to-N connection, enable the RS control (ON) if you connect the Unit to a device on the N side. For a two-wire connection, always enable the RS control (ON).		

All pins are turned OFF by default.

Use a narrow-tipped tool such as a flat-blade screwdriver to change the settings of the DIP switches.

● RS-422A/485 Terminal Block

RDA- RDB+ SDA- SDB+ SHLD

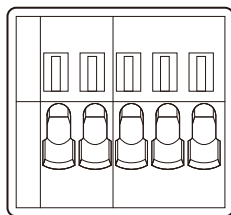

Abbreviation	Four-wire type selected		Two-wire type selected	
	Signal name	I/O	Signal name	I/O
RDA-	Reception data -	Input	Communication data -	I/O*1
RDB+	Reception data +		Communication data +	
SDA-	Transmission data -	Output	Communication data -	I/O*1
SDB+	Transmission data +		Communication data +	
SHLD	Shield			

*1. For two-wire connection, either the RDA-/RDB+ pair or SDA-/SDB+ pair can be used.

3-4 Analog I/O Option Board

3-4-1 Models and Specifications

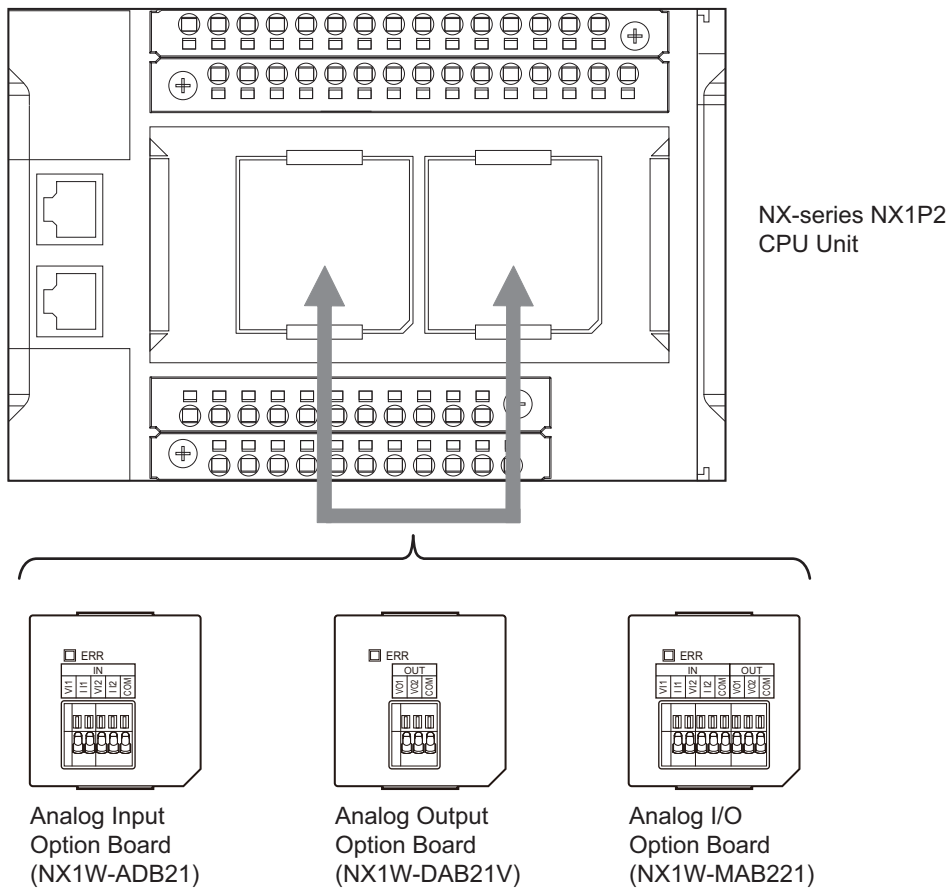

This section explains the specifications that are common to all types of Analog I/O Option Board. Refer to 3-4-3 *Part Names and Functions* on page 3-27 for details.

Item	Specification					
Model	NX1W-ADB21		NX1W-DAB21V		NX1W-MAB221	
I/O	Analog input		Analog output		Analog I/O	
Voltage input	0 to 10 V	2 channels	---		0 to 10 V	2 channels
Current input	0 to 20 mA	total	---		0 to 20 mA	total
Voltage output	---		0 to 10 V	2 channels	0 to 10 V	2 channels
Connection type	Screwless clamping terminal block (5 terminals)		Screwless clamping terminal block (3 terminals)		Screwless clamping terminal block (8 terminals)	
Applicable wire size	AWG24 to 20					
Dimensions (mm)*1	35.9 × 35.9 × 28.2 (W×H×D)					
Weight	24 g		24 g		26 g	
Power consumption	Included in the CPU Unit power consumption. The Option Board power consumption is included in the definition of the CPU Unit power consumption.					
Isolation method	No isolation					

*1. Projecting parts such as a terminal block is not included. When the Option Board is mounted to the CPU Unit, it protrudes through the CPU Unit surface. The details are explained in 5-3-13 *Assembled Appearance and Dimensions* on page 5-38.

3-4-2 Purpose

The Analog I/O Option Board allows inputs from devices such variable resistors and process-control sensors. It also enables you to control inverters.

Analog inputs that can be processed are 0 to 10 V inputs from devices including variable resistors, and 4 to 20 mA inputs from process-control sensors.

Analog output range from 0 to 10 V, which allow the CPU Unit to control inverters directly.

Refer to the *NX-series NX1P2 CPU Unit Built-in I/O and Option Board User's Manual* (Cat. No. W579) for details on how to use the Option Boards.

3-4-3 Part Names and Functions

Analog Input Option Board (NX1W-ADB21)

Status indicator

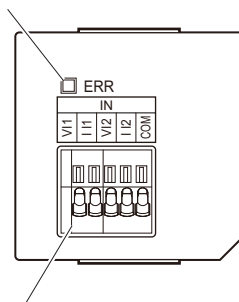

Analog input terminal block

● Status Indicator

Indicator	Color	Status	Description
ERR	Red		Lit. An Option Board error (WDT) was detected by the self-diagnostic function.
			Flashing. A communications error occurred between the Option Board and the CPU Unit.
			Not lit. Normal operation

● Analog Input Terminal Array

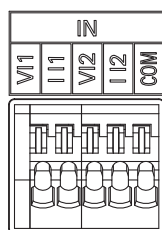

Abbrevia- tion	Signal name
V I1	Voltage input 1
I I1	Current input 1
V I2	Voltage input 2
I I2	Current input 2
COM	Input common



Precautions for Correct Use

When you use the current input, be sure to short-circuit V I1 with I I1, and short-circuit V I2 with I I2.

● Analog Input Specifications

Item	Specification	
	Voltage input	Current input
Input method	Single-ended input	Single-ended input
Input range	0 to 10 V	0 to 20 mA
Input conversion range	0 to 10.24 V	0 to 30 mA
Absolute maximum rating	-1 to 15 V	-4 to 30 mA
Input impedance	200 kΩ min.	Approx. 250 Ω
Resolution	1/4,000 (full scale)	1/2,000 (full scale)
Overall accuracy	25°C	±0.5% (full scale)
	0 to 55°C	±1.0% (full scale)
Averaging processing	Not provided	
Conversion time	Internal sampling time: 2 ms per point*1	

*1. Refer to the *NX-series NX1P2 CPU Unit Built-in I/O and Option Board User's Manual* (Cat. No. W579) for information on refresh time.

Analog Output Option Board (NX1W-DAB21V)

Status indicator

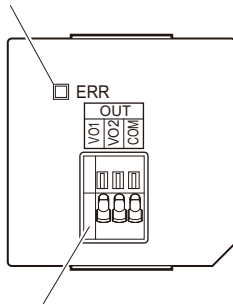

Analog output terminal block

● Status Indicator

Indicator	Color	Status	Description
ERR	Red		Lit. An Option Board error (WDT) was detected by the self-diagnostic function.
			Flashing. A communications error occurred between the Option Board and the CPU Unit.
			Not lit. Normal operation

● Analog Output Terminal Array

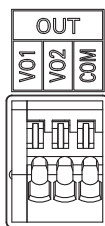

Abbreviation	Signal name
VO1	Voltage output 1
VO2	Voltage output 1
COM	Output common

● Analog Output Specifications

Item	Specification	
	Voltage output	Current output
Output range	0 to 10 V	---
Output conversion range	0 to 10.24 V	---
Allowable load resistance	2 kΩ min.	---
Output impedance	0.5 Ω max.	---
Resolution	1/4,000 (full scale)	---
Overall accuracy	25°C	±0.5% (full scale)
	0 to 55°C	±1.0% (full scale)
Conversion time	Internal sampling time: 2 ms per point*1	

*1. Refer to the NX-series NX1P2 CPU Unit Built-in I/O and Option Board User's Manual (Cat. No. W579) for information on refresh time.

Analog I/O Option Board (NX1W-MAB221)

Status indicator

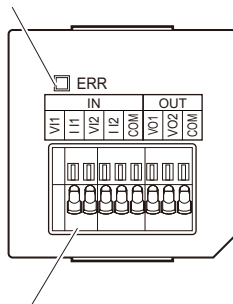

Analog output terminal block

● Status Indicator

Indicator	Color	Status	Description
ERR	Red		Lit. An Option Board error (WDT) was detected by the self-diagnostic function.
			Flashing. A communications error occurred between the Option Board and the CPU Unit.
			Not lit. Normal operation

● Analog I/O Terminal Array

	Abbreviation		Signal name	
	IN	OUT	Abbreviation	Signal name
IN	V1	VO1	V11	Voltage input 1
	I1	VO2	I11	Current input 1
	V2	COM	V12	Voltage input 2
	I2	COM	I12	Current input 2
	COM	COM	COM	Input common
OUT	VO1	COM	VO1	Voltage output 1
	VO2	COM	VO2	Voltage output 2
	COM	COM	COM	Output common



Precautions for Correct Use

When you use the current input, be sure to short-circuit V I1 with I 1, and short-circuit V I2 with I 2.

● Analog I/O Specifications

Item		Specification		
		Voltage I/O	Current I/O	
Analog input section	Input method	Single-ended input		
	Input range	0 to 10 V	0 to 20 mA	
	Input conversion range	0 to 10.24 V	0 to 30 mA	
	Absolute maximum rating	-1 to 15 V	-4 to 30 mA	
	Input impedance	200 k Ω min.	Approx. 250 Ω	
	Resolution	1/4,000 (full scale)	1/2,000 (full scale)	
	Overall accuracy	25°C	$\pm 0.5\%$ (full scale)	$\pm 0.6\%$ (full scale)
		0 to 55°C	$\pm 1.0\%$ (full scale)	$\pm 1.2\%$ (full scale)
Averaging processing	Not provided			
Analog output section	Output range	0 to 10 V	---	
	Output conversion range	0 to 10.24 V	---	
	Allowable load resistance	2 k Ω min.	---	
	Output impedance	0.5 Ω max.	---	
	Resolution	1/4,000 (full scale)	---	
	Overall accuracy	25°C	$\pm 0.5\%$ (full scale)	---
		0 to 55°C	$\pm 1.0\%$ (full scale)	---
Conversion time	Internal conversion time: 6 ms (Total of 4 channels) ^{*1}			

*1. Refer to the *NX-series NX1P2 CPU Unit Built-in I/O and Option Board User's Manual* (Cat. No. W579) for information on refresh time.

3-5 Power Supply-related Units

The following NX Units are the NX-series power supply-related Units. When configuring NX Units, you can use these Units as necessary to supply power to the NX Units. These NX Units are collectively called as the System Units.

- Additional NX Unit Power Supply Unit
- Additional I/O Power Supply Unit
- I/O Power Supply Connection Unit

Refer to *4-1-2 NX-series Power Supply-related Units* on page 4-4 for details on the functions of NX-series power supply-related Units.

3-6 NX Units

The NX Units perform I/O processing with connected external devices. The NX Units refers to NX-series NX-□□□□□□ Units.

Up to eight NX Units can be connected to the CPU Unit.

The following is an example of NX Unit's part names and functions.

For details on the part names and functions of NX Units, refer to the user's manual for each NX Unit.

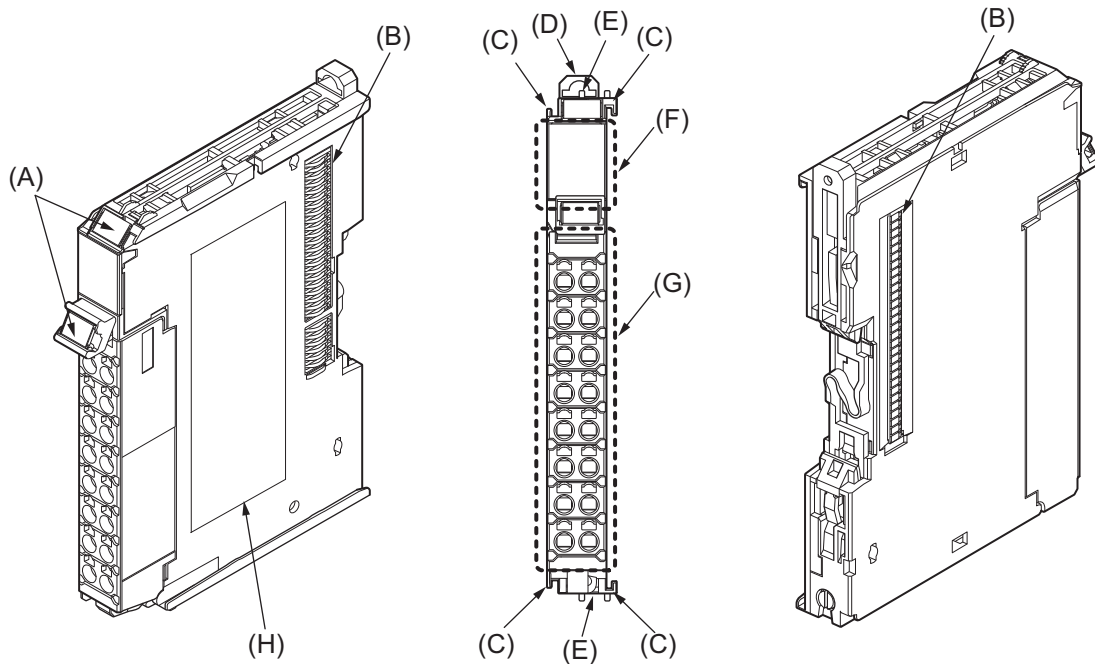

Symbol	Name	Function
A	Marker attachment location	The locations where markers are attached. OMRON markers are pre-installed at the factory. You can also install commercially available markers.
B	NX bus connector	This connector is used to connect another Unit.
C	Unit hookup guides	These guides are used to connect two Units.
D	DIN Track mounting hook	This hook is used to mount the NX Unit to a DIN Track.
E	Protrusions for removing the Unit	The protrusions to hold when removing the Unit.
F	Indicators	The indicators show the current operating status of the Unit.
G	Terminal block	The terminal block is used to connect external devices. The number of terminals depends on the type of Unit.
H	Unit specifications	The specifications of the Unit are given here.

3-7 Sysmac Studio

This section describes the models and connecting methods of the Sysmac Studio.

3-7-1 Model Numbers

The model numbers of the Sysmac Studio are given in the following table. The model numbers are different for the media and licenses.

Product	Configuration software	Media	Number of user licenses	Model
Sysmac Studio Standard Edition	Sysmac Studio The following Support Software is also included. Network Configurator CX-Integrator CX-Protocol CX-Designer	DVD	---	SYSMAC-SE200D
		Licenses	1	SYSMAC-SE201L
			3	SYSMAC-SE203L
			10	SYSMAC-SE210L

3-7-2 Connection

With an NX1P2 CPU Unit, you can connect the Sysmac Studio online in the following ways.

Configuration

● Connection with EtherNet/IP

- 1:1 Connection

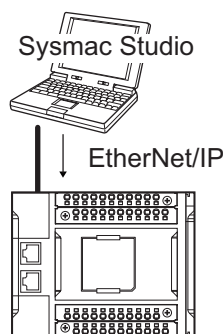

- A direct connection is made from the Sysmac Studio. The IP address and connection device do not need to be specified. ^{*1}
- You can make the connection whether or not an Ethernet switch is used.
- Support for Auto-MDI enables the use of cross cables or straight cables if a direct connection is made.

- 1:N Connection

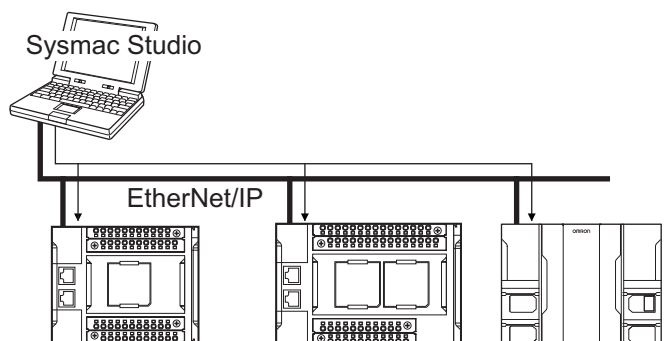

Directly specify the IP address of the remote device.



Additional Information

The Sysmac Studio cannot connect online to an NJ/NX-series CPU Unit in the following type of configuration.

- If the built-in EtherNet/IP port is not used, you cannot connect to an NJ/NX-series CPU Unit on an EtherNet/IP network.

Example: Connection to NJ/NX-series CPU Unit Routing through an EtherNet/IP Unit or Built-in Port

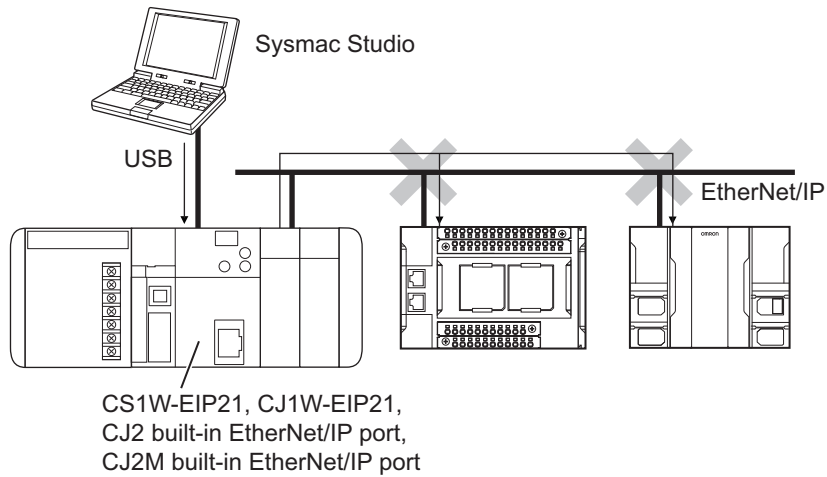

- You cannot route through any networks other than EtherNet/IP networks.

4

Designing the Power Supply System

This section describes how to design the power supply system for the NX-series NX1P2 CPU Unit.

4

4-1	Power Supply System and Design Concepts	4-2
4-1-1	Power Supply System and Types of Power Supplies	4-2
4-1-2	NX-series Power Supply-related Units	4-4
4-1-3	Design Concepts for Power Supply to the CPU Rack	4-6
4-2	Designing the NX Unit Power Supply System	4-7
4-2-1	Procedure for Designing the NX Unit Power Supply System	4-7
4-2-2	Calculation Example for the NX Unit Power Supply	4-8
4-3	Designing the I/O Power Supply System	4-10
4-3-1	I/O Power Supply Method	4-10
4-3-2	Designing the I/O Power Supply from the NX Bus	4-11
4-3-3	Designing the I/O Power Supply from External Sources	4-16
4-3-4	Designing I/O Power Supply for the Built-in I/O	4-17
4-3-5	Restrictions on Inrush Current for ON/OFF Operation	4-18
4-4	Selecting External Power Supplies and Protective Devices	4-19
4-4-1	Selecting the Unit Power Supply	4-19
4-4-2	Selecting the I/O Power Supplies	4-21
4-4-3	Selecting Protective Devices	4-22

4-1 Power Supply System and Design Concepts

This section describes the power supply system for the CPU Rack of the NX-series NX1P2 CPU Unit and the design concepts.

4-1-1 Power Supply System and Types of Power Supplies

Power Supply System Configuration Diagram

An example of a power supply system configuration diagram for the CPU Rack of the NX1P2 CPU Unit is shown below.

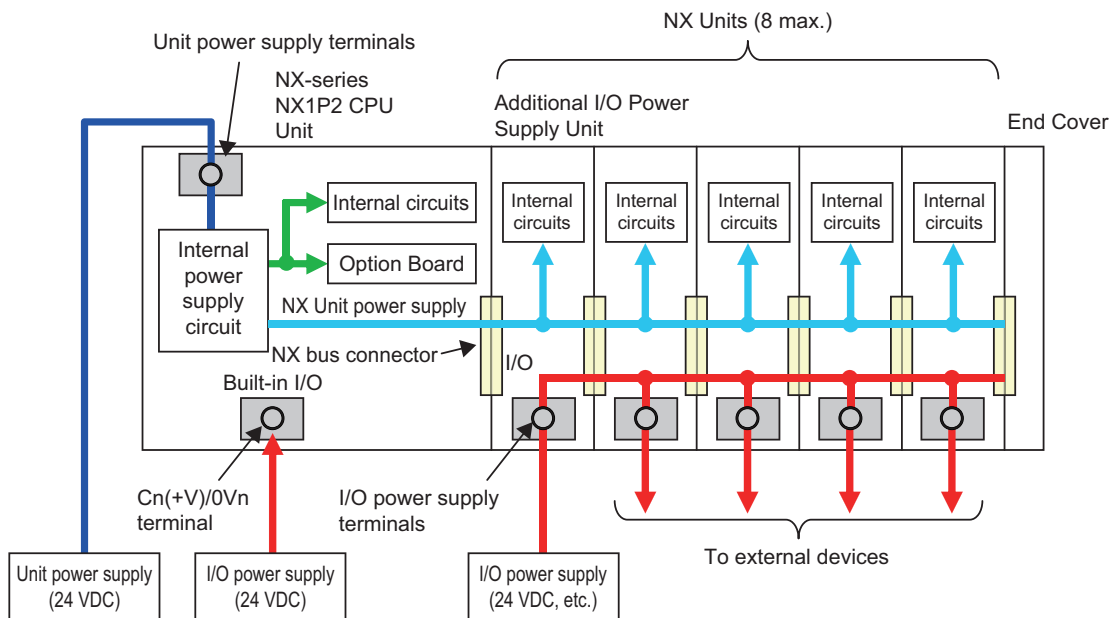

Power Supply Types

There are the following two types of power supplies that supply power to the CPU Rack of an NX1P2 CPU Unit.

Power supply type		Description
Unit power supply		<p>This is the power supply for generating the internal power supply required for the CPU Rack to operate.</p> <p>This power supply is connected to the Unit power supply terminals on the CPU Unit. From the Unit power supply, the internal power supply circuit in the CPU Unit generates the internal circuit power supply, Option Board power supply and NX Unit power supply. The internal circuits of the NX Units operate on the NX Unit power supply. The NX Unit power supply can supply up to 10 W power to the NX Units through the NX bus connectors.</p>
I/O power supply	For NX Units	<p>This power supply is used for driving the I/O circuits of the NX Units and for the connected external devices.</p> <p>When the type of the I/O power supply to NX Units^{*1} is the supply from NX bus, this power supply is connected to the I/O power supply terminals on the Additional I/O Power Supply Unit. The I/O power supply is supplied to the NX Units from the I/O power supply terminals and through the NX bus connectors.</p> <p>The CPU Unit does not have the I/O power supply terminals used for the NX Units. On the CPU Rack, the maximum I/O power supply current that can be supplied to the NX Units from the Additional I/O Power Supply Unit and through the NX bus connectors is 4 A.</p> <p>When the type of the I/O power supply to all NX Units on the CPU Rack is the supply from external source, the Additional I/O Power Supply Unit is not needed.</p> <p>The I/O power supply for the NX Units are independent from the I/O power supply for the CPU Unit's built-in I/O.</p>
	For built-in I/O	<p>This power supply is used for driving the PNP (sourcing) type built-in I/O output circuit. This I/O power supply is independent from the I/O power supply for the NX Units. Refer to Current consumption from I/O power supply in the table under <i>Output Specifications</i> on page 3-17 in 3-1-4 <i>Terminal Blocks</i> on page 3-12 for details on the current specifications.</p>

*1. Refer to the datasheet included in the user's manual of the specific NX Unit for the supply method of each NX Unit model.



Precautions for Correct Use

Always use separate power supplies for the Unit power supply and the I/O power supply. If you supply power from the same power supply, noise may cause malfunctions.

4-1-2 NX-series Power Supply-related Units

NX-series NX1P2 CPU Unit supplies the NX Unit power to the NX Units on the CPU Rack. The power-related units for the CPU Unit NX series are available in the following types.

For the specifications of NX-series power supply-related Units, refer to the *NX-series System Units User's Manual* (Cat. No. W523). For information on the most recent lineup of the NX-series power supply-related Units, refer to the NX-series catalogs or OMRON websites, or ask your OMRON representative.

The feature and purpose of each Unit in the NX Unit configuration with the NX-series NX1P2 CPU Unit are given below.

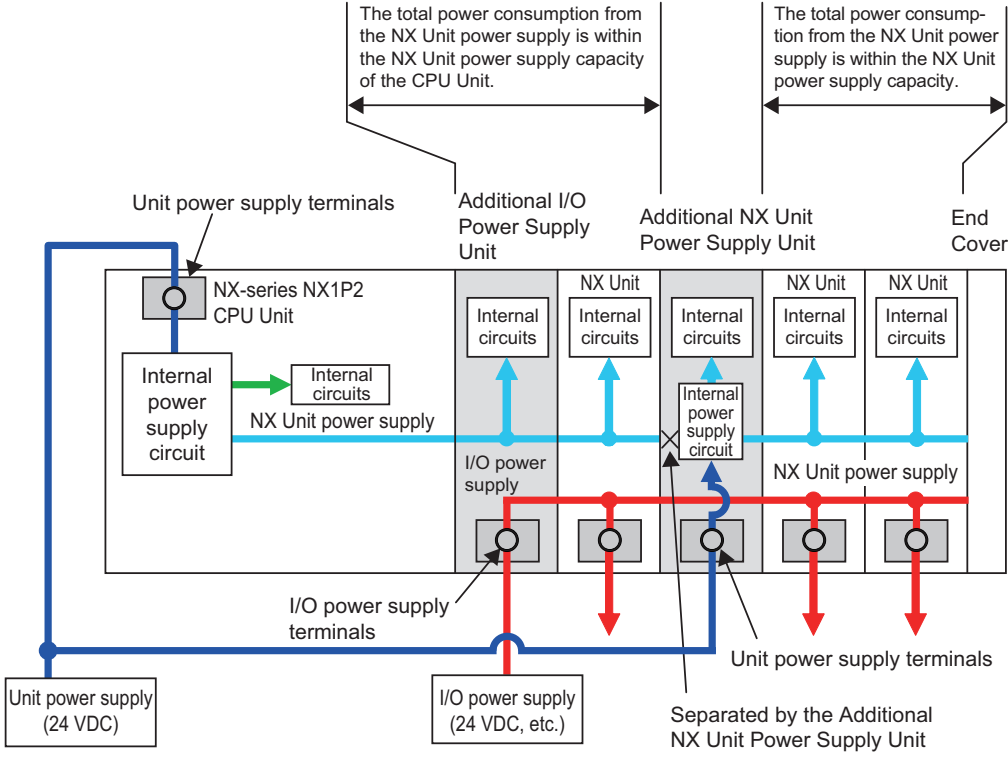
Unit name	Function
Additional NX Unit Power Supply Unit	<p data-bbox="411 734 1437 824">This NX Unit provides NX Unit power supply. This NX Unit is used when the total power consumption of the NX Units on the CPU Rack exceeds the NX Unit power supply capacity of the CPU Unit.</p>  <p data-bbox="411 1668 1422 1724">The I/O power supply for the Additional NX Unit Power Supply Unit is connected to the NX Unit on the left through the NX bus connector.</p>

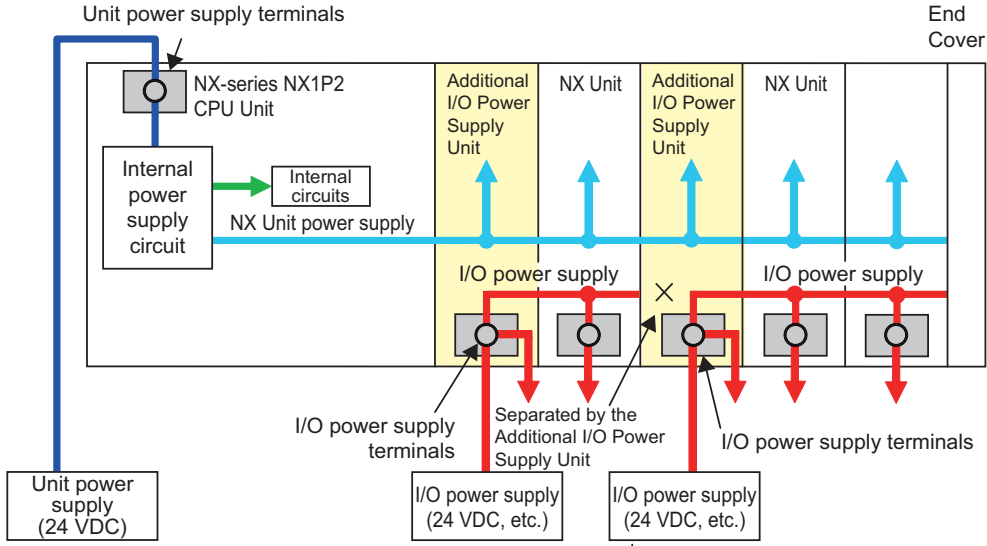
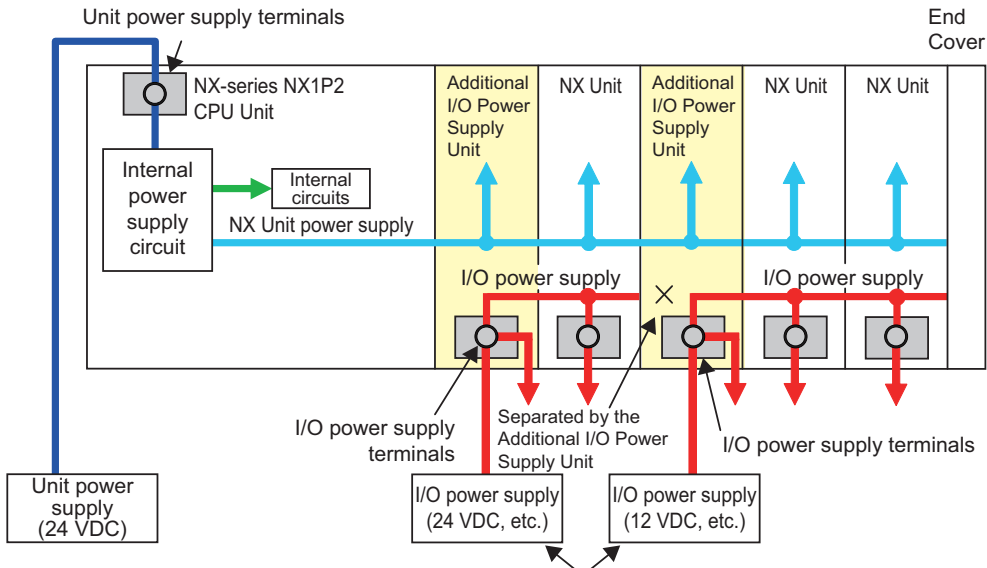
Unit name	Function
<p>Additional I/O Power Supply Unit</p>	<p>This NX Unit provides additional I/O power supply. This Unit is used when the type of the I/O power supply to NX Units connected to the CPU Unit is the supply from NX bus.</p> <p>Add one or more of this NX Unit to use in the following cases.</p> <p>(a) When the I/O power supply capacity is insufficient</p> <ul style="list-style-type: none"> • When the total current consumption from I/O power supply exceeds 4 A • When a voltage drop in the I/O power supply causes the voltage of the I/O power supply to go below the voltage specifications of the I/O circuits or connected external devices <p>(b) Separating the I/O power supply</p> <ul style="list-style-type: none"> • When connected external devices have different I/O power supply voltages • When separating the power supply systems <p>Case (a)</p>  <p>When the I/O power supply becomes the following states for the subsequent NX Units.</p> <ul style="list-style-type: none"> • When it exceeds the maximum I/O power supply current, 4 A • When it goes below the voltage specifications of the connected external devices <p>Case (b)</p>  <p>- When different I/O power supply voltage are used. - When separating the power supply systems.</p> <p>The NX Unit power supply of the Additional I/O Power Supply Unit is connected to the NX Unit on the left through the NX bus connector.</p>

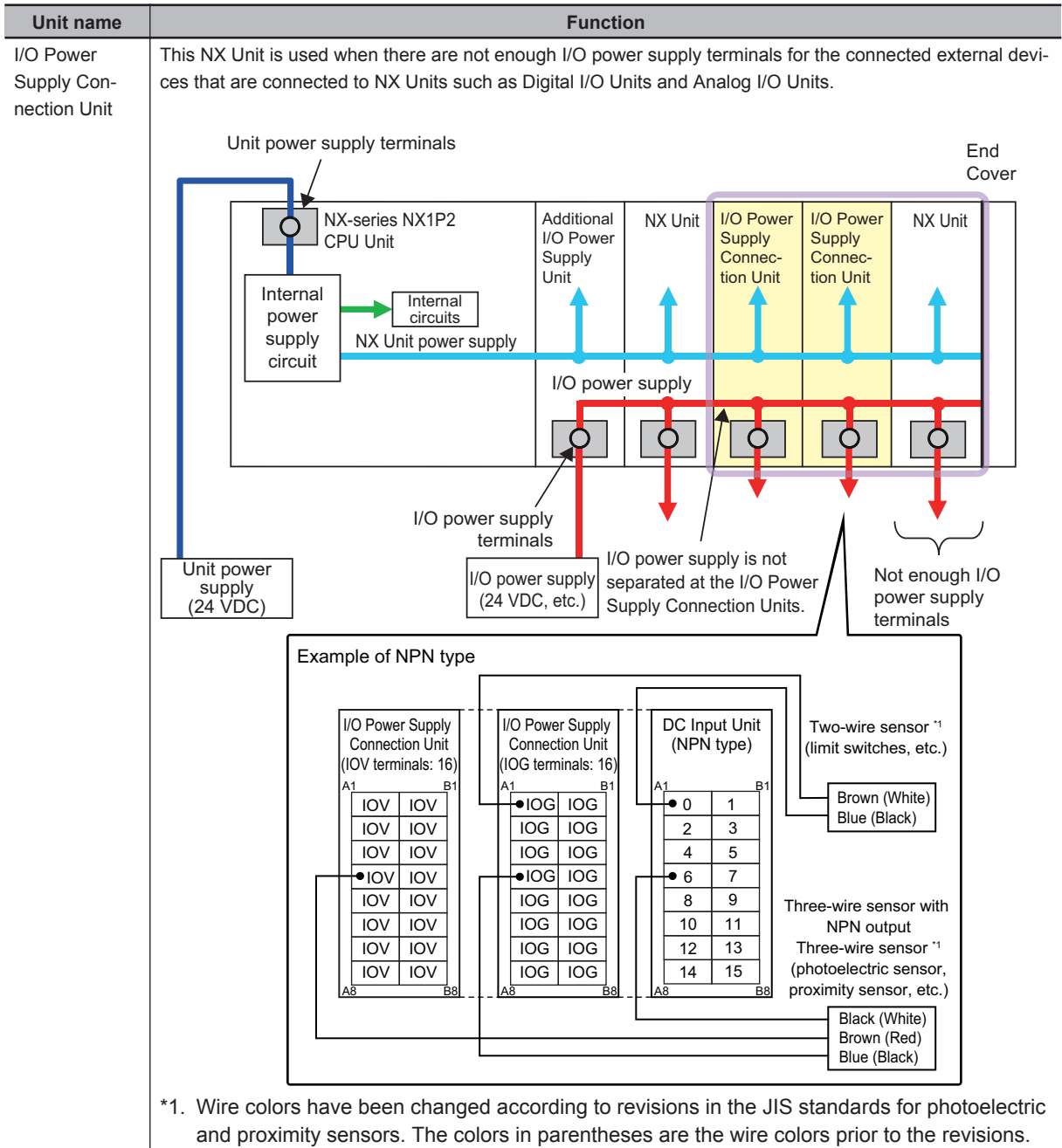

4-1-3 Design Concepts for Power Supply to the CPU Rack

The following must be studied when designing the power supply system to CPU Rack.

- The NX Unit power supply and I/O power supply systems must be designed and then the design conditions for both must be confirmed.
- The external power supplies (i.e., Unit power supply and I/O power supplies) must be selected.

4-2 Designing the NX Unit Power Supply System

This section describes how to design the NX Unit power supply to the CPU Rack of the NX-series NX1P2 CPU Unit.

4-2-1 Procedure for Designing the NX Unit Power Supply System

The total power consumption from the NX Unit power supply must not exceed the NX Unit power supply capacity of the Unit that supplies the NX Unit power.

Use the following procedure to design the NX Unit power supply.

- 1** Calculate the total power consumption from the NX Unit power supply that is required by the NX Units that are connected to the CPU Unit.
- 2** If the total power consumption from the NX Unit power supply exceeds the NX Unit power supply capacity of the CPU Unit, add an Additional NX Unit Power Supply Unit to the right of an NX Unit before the capacity is exceeded.
- 3** Calculate the total power consumption from the NX Unit power supply that is required by the NX Units that are connected after the Additional NX Unit Power Supply Unit. If the total power consumption of those NX Units exceeds the NX Unit power supply capacity of the Additional NX Unit Power Supply Unit, add another Additional NX Unit Power Supply Unit to the right of an NX Unit before the capacity is exceeded.
- 4** Repeat step 3 until the design conditions for the NX Unit power supply are met.

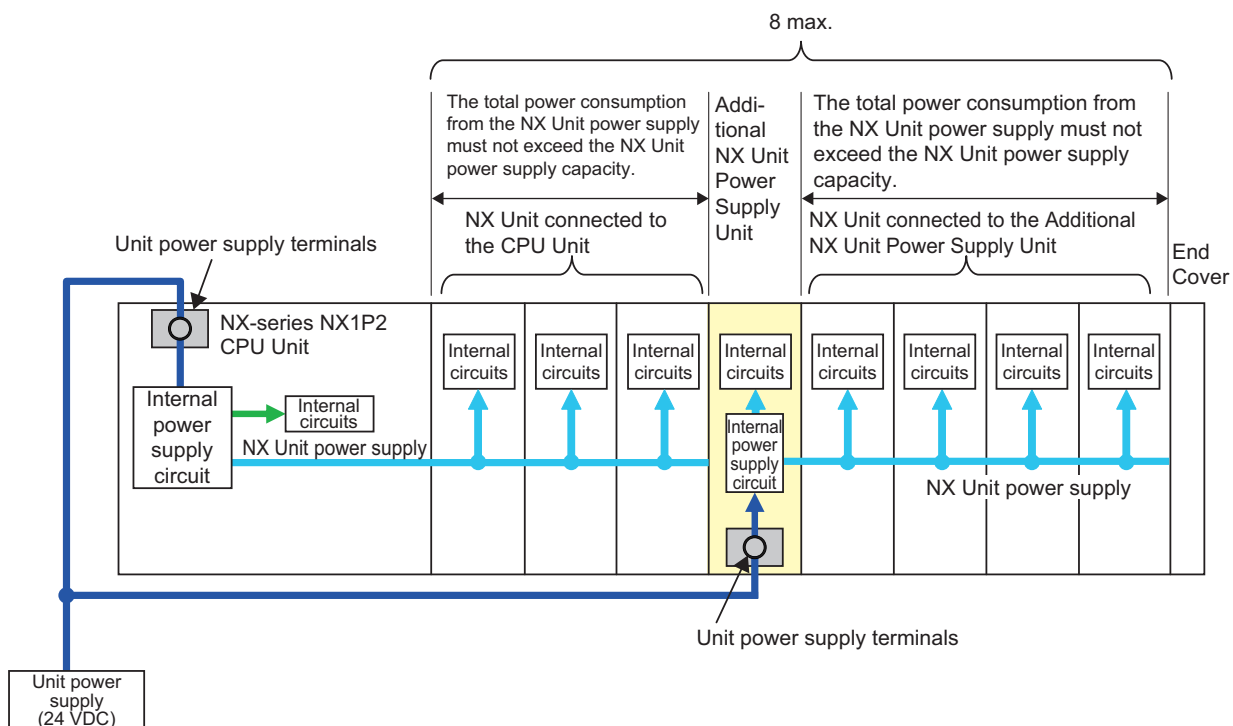

● NX Unit Power Supply Capacity and Restrictions

The internal power supply circuits of the CPU Unit or Additional NX Unit Power Supply Unit supply the NX Unit power to the NX Units.

The NX Unit power supply capacity does not include the NX Unit power consumption of the Additional NX Unit Power Supply Units.

The power supply capacity of the CPU Unit is 10 W.

For restrictions on the Additional NX Unit Power Supply Unit, refer to the *NX-series System Units User's Manual* (Cat. No. W523).



Precautions for Correct Use

- Do not exceed the NX Unit power supply capacity. If you exceed the NX Unit power supply capacity, malfunction may occur.
- Use the same Unit power supply to supply the Unit power to the entire CPU Rack. If you supply power from different Unit power supplies, differences in electrical potential may cause unexpected currents in the NX Unit power supply, which may result in failure or malfunction.

4-2-2 Calculation Example for the NX Unit Power Supply

This section provides a calculation example for the NX Unit power supply.

● Unit Configuration Example

Name	Model	Quantity	Power consumption/Unit*1
CPU Unit	NX1P2-1140DT	1	7.05 W
Additional I/O Power Supply Unit	NX-PF0630	1	0.85 W
Digital Input Unit	NX-ID3317	4	0.90 W
Relay Output Unit	NX-OC2633	3	1.20 W

*1. For the power consumption of NX Units connected to CPU Unit, refer to the user's manuals for the respective NX Units.

● Calculating the Total Power Consumption from the NX Unit Power Supply

Calculate the total power consumption from the NX Unit power supply that is required by the NX Units that are connected to the CPU Unit.

Total power consumption from NX Unit power supply [W] = $0.85 \text{ W} \times 1 + 0.90 \text{ W} \times 4 + 1.20 \text{ W} \times 3 = 8.05 \text{ W}$

● Confirming the NX Unit Power Supply Capacity of the CPU Unit

The NX Unit power supply capacity is 10 W max.

Therefore, in this example, the total power consumption from the NX Unit power supply is 8.05 W, and the NX Unit power supply capacity is 10 W max., so the design conditions are met.



Additional Information

Excess or insufficiency in the NX Unit power supply capacity can be easily checked when the Unit configuration is created on the CPU and Expansion Racks Tab Page on the Sysmac Studio.

Use the following procedure to check the power supply capacity.

On the CPU and Expansion Racks Tab Page on the Sysmac Studio, select the Unit to supply NX Unit power. The power that is supplied by the NX Unit power supply (i.e., the total power consumption) and the power supply capacity are displayed for the **Supply Power/Available Power** parameter.

The following example is for when selecting the NX1P2 CPU Unit.

Item name	Value
Device name	NXBus
Model name	NX1P2-1140DT
Product name	NX series controller
Unit version	1.13
NX Unit Number	0
NX Unit Mounting Setting	---
Serial Number	---
Supply Power/Available Power	8.05 / 10.00 W
Unit width	148 mm

If the power to supply exceeds the NX Unit power supply capacity of the Unit that is selected to supply the NX Unit power, a yellow warning icon is displayed by the first NX Unit for which there is not sufficient capacity and also by all the remaining NX Units.

Item name	Value
Device name	NXBus
Model name	NX1P2-1140DT
Product name	NX series controller
Unit version	1.13
NX Unit Number	0
NX Unit Mounting Setting	---
Serial Number	---
Supply Power/Available Power	10.35 / 10.00 W
Unit width	148 mm

The Sysmac Studio does not consider the I/O power supply design conditions. When actually designing the power supply, refer to 4-3-2 *Designing the I/O Power Supply from the NX Bus* on page 4-11.

4-3 Designing the I/O Power Supply System

This section describes how to design the I/O power supply to the NX Units connected to the NX-series NX1P2 CPU Unit.

4-3-1 I/O Power Supply Method

There are the following three methods to supply the I/O power supply to the NX Units depending on the type and model of the NX Units.

Supply method	Description
Supply from the NX bus	Power is supplied through the NX bus connectors by connecting an I/O power supply to the I/O power supply terminals on the Additional I/O Power Supply Units.
Supply from external source	Power is supplied to the Units from an external source. I/O power is supplied by connecting an I/O power supply to the terminal blocks on the Units.
No supply	The I/O power supply is not needed when the NX Unit does not use it for the connected external devices, or when power for the interface is generated inside the NX Unit.

Refer to the user's manuals for individual NX Units or to the *NX-series Data Reference Manual* (Cat. No. W525) for the power supply method for specific NX Units.

An example is shown below.

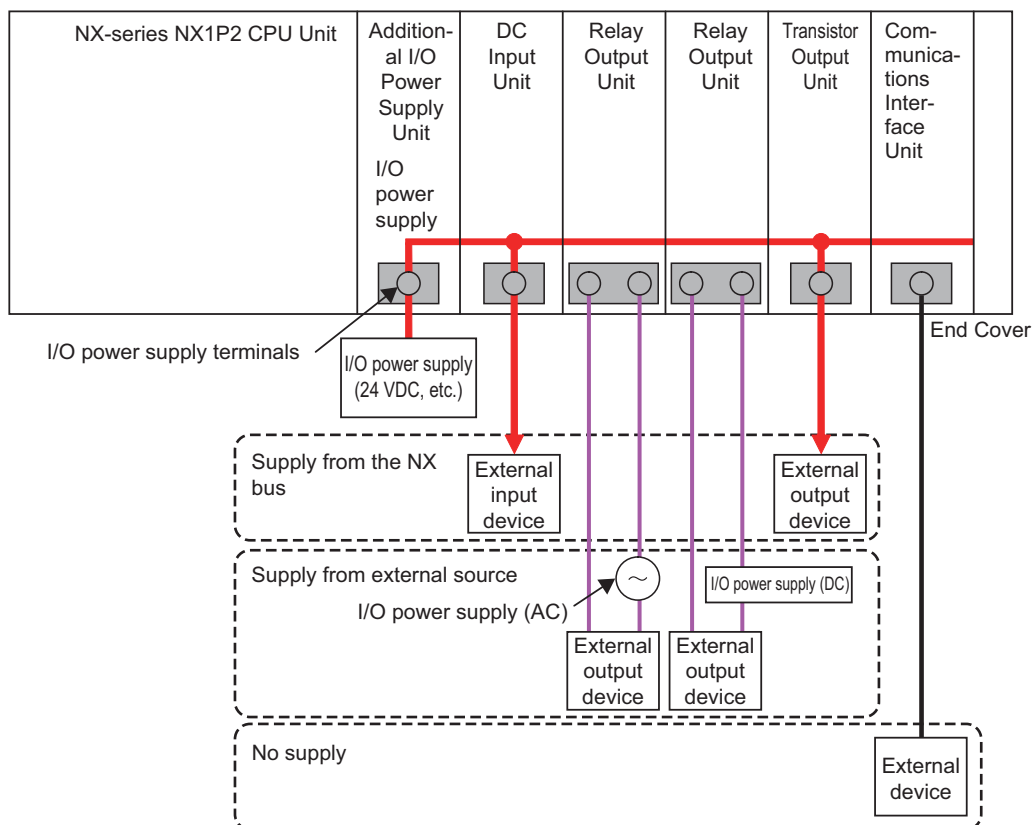

4-3-2 Designing the I/O Power Supply from the NX Bus

Procedure for Designing the I/O Power Supply

The procedure is explained under the precondition that an Additional I/O Power Supply Unit is connected to the right side of the CPU Unit because an NX Unit that requires the power supply from NX bus is mounted on the CPU Rack.

Make sure that the following design conditions are met when you design the I/O power supply from the NX bus.

- The total current consumption from the I/O power supply must not exceed the maximum I/O power supply current of the Unit that supplies the I/O power.
- The voltage drop in the I/O power supply must be within the voltage specifications of the I/O circuits of the NX Units and the connected external devices.

Use the following procedure to design the I/O power supply.

- 1** Calculate the total current consumption from the I/O power supply of the NX Units that are connected to the CPU Unit and the CPU Unit, and calculate the voltage drop in the I/O power supply.
- 2** Add an Additional I/O Power Supply Unit in either of the following cases, a) or b). Add the Additional I/O Power Supply Unit to the right of the NX Unit for which both a) and b) do not apply.
 - a) The total current consumption for the I/O power supply exceeds 4 A.
 - b) Voltage drop in the I/O power supply causes the voltage of the I/O power supply to go below the voltage specifications of the I/O circuits of the NX Units or the connected external devices.
- 3** Calculate the voltage drop in the I/O power supply after the Additional I/O Power Supply Unit and the total current consumption from the I/O power supply that is required by the Additional I/O Power Supply Unit and by the NX Units that are connected after the Additional I/O Power Supply Unit. Add another Additional I/O Power Supply Unit in either of the following cases, a) or b). Add the Additional I/O Power Supply Unit to the right of the NX Unit for which both a) and b) do not apply.
 - a) The total current consumption for the I/O power supply exceeds the I/O power supply capacity of the Additional I/O Power Supply Unit.
 - b) Voltage drop in the I/O power supply causes the voltage of the I/O power supply to go below the voltage specifications of the I/O circuits of the NX Units or the connected external devices.
- 4** Repeat step 3 until the design conditions for the I/O power supply are met.

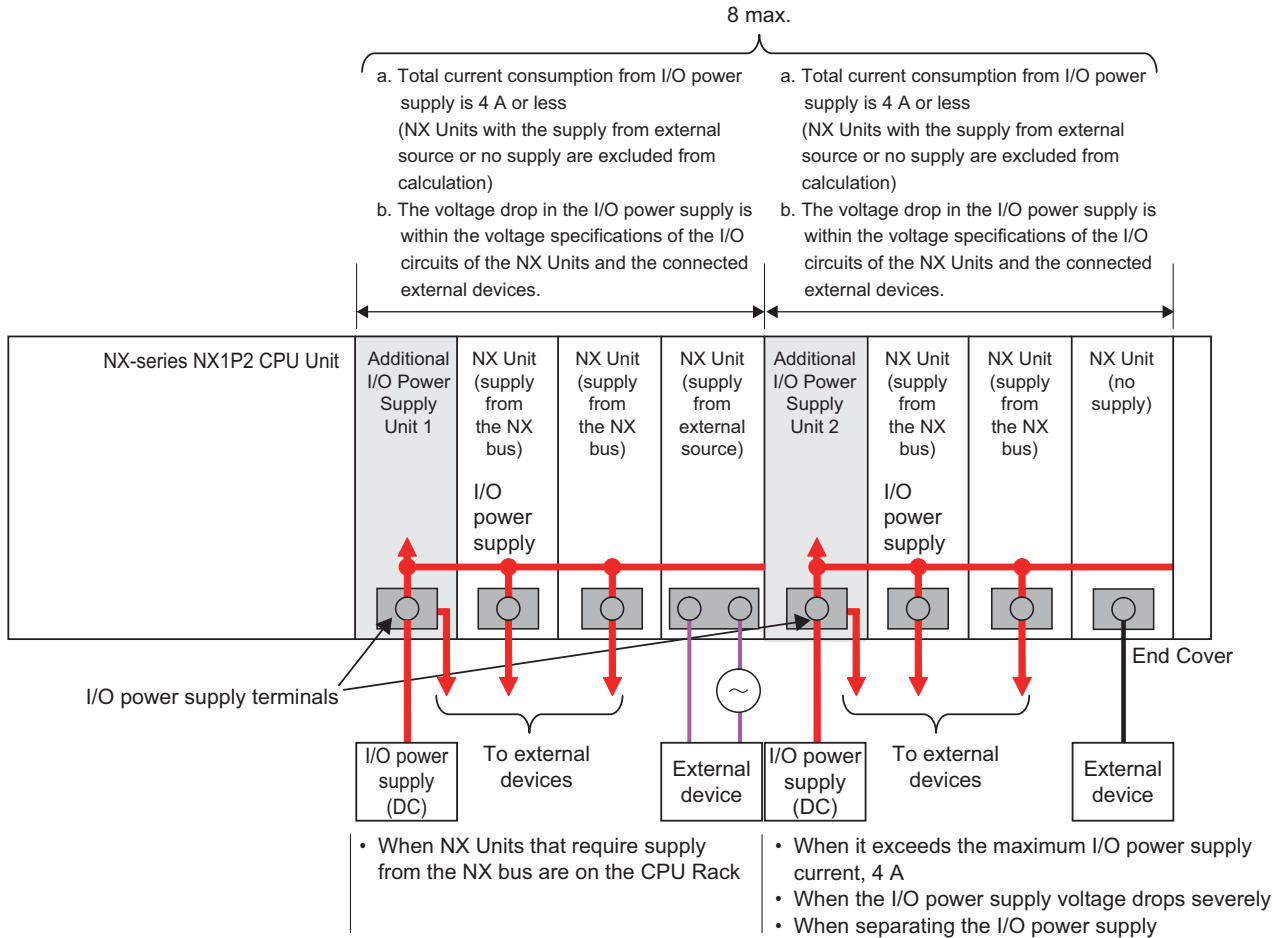

● Maximum I/O Power Supply Current

The maximum I/O power supply current is the maximum current that the I/O power supply that is connected to the Additional I/O Power Supply Unit can supply through the NX bus connectors to the NX Units.

When an Additional I/O Power Supply Unit is used on the CPU Rack, the maximum value is 4 A regardless of the Unit specifications.

For example, when an NX-PF0730 Additional I/O Power Supply Unit is used, its maximum I/O power supply current is 10 A. However, you must operate the NX-PF0730 at 4 A or less when you use it on the CPU Rack.



Precautions for Safe Use

Use the I/O power supply current for the CPU Rack of NX1P2 CPU Unit at 4 A or less. Using the currents that are outside of the specifications may cause failure or damage.

Calculating the Total Current Consumption from the I/O Power Supply

The total current consumption from the I/O power supply from the NX bus is the total of the following current consumptions.

- The current consumption from the I/O power supply that is required for the Additional I/O Power Supply Unit and for the NX Units that are connected to the Additional I/O Power Supply Unit
- The current consumption between the NX Units and the connected external devices

Current consumption item	Description
Current consumption from I/O power supply	This is the current that is consumed by the internal circuits that operate on the I/O power supply. Specific values are given in the user's manuals for individual Units.
Current consumption between the NX Units and the connected external devices	This is the current that is consumed between the NX Units and the connected external devices. For example, this is the current consumed by a Digital Input Unit to supply power to photoelectric sensors or to turn ON the input circuits in the Digital Input Unit. The current consumption depends on the type of I/O circuit in the NX Unit, the number of I/O points that are used, and the current consumption of the connected external device. It must be calculated for each NX Unit.

● Calculation Example of I/O Power Supply Capacity

An example of calculating the required power supply capacity of the I/O power supply is given below.

Configuration and Conditions

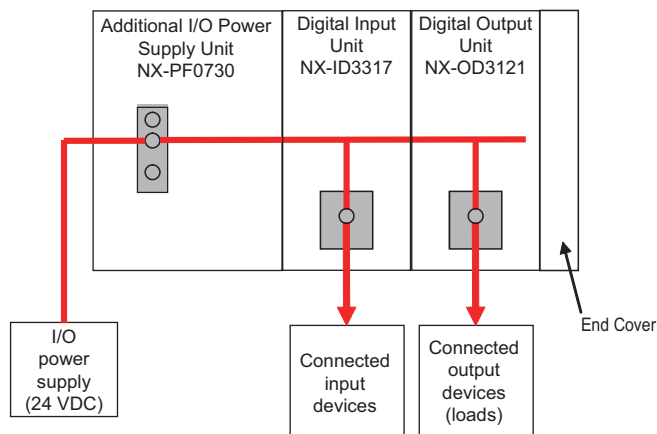

Item		Condition
I/O power supply voltage		24 VDC
Inputs	Number of inputs used (that turn ON simultaneously)	4 points
	Current consumption of connected input devices	50 mA/point
Outputs	Number of outputs (that turn ON simultaneously)	4 points
	Load current of connected loads	125 mA/point
	Current consumption of connected output devices	50 mA/point

I/O power is supplied to the NX-ID3317 and NX-OD3121 from the NX bus.

a. Unit Specifications

Model	Current consumption from I/O power supply	Input current
NX-PF0730	10 mA	---
NX-ID3317	0 mA	6 mA/point
NX-OD3121	10 mA	---

b. Calculations

The current consumption from the I/O power supply for each Unit is calculated as follows.

NX-PF0730 Current Consumption	=	Current consumption from I/O power supply
	=	10 mA

NX-ID3317 Current Consumption	=	Current consumption from I/O power supply + (Input current × Number of inputs used) + Total current consumption of connected input devices
	=	0 mA + (6 mA × 4 points) + (50 mA × 4 points)
	=	224 mA

NX-OD3121 Current Consumption	=	Current consumption from I/O power supply + Total load current of connected loads + Total current consumption of connected output devices
	=	10 mA + (125 mA × 4 points) + (50 mA × 4 points)
	=	710 mA

The required power supply capacity for the I/O power supply is calculated as follows.

Power supply capacity of I/O power supply	=	(Current consumed by NX-PF0730) + (Current consumed by NX-ID3317) + (Current consumed by NX-OD3121)
	=	10 mA + 224 mA + 710 mA
	=	944 mA

Calculating the Voltage Drop in the I/O Power Supply

Voltage drop occurs in the CPU Units and NX Units due to the contact resistance at the points where Units are connected to each other. Design the I/O power supply system to maintain the voltage specifications of the NX Unit I/O circuits and connected external devices even if the voltage of the I/O power supply drops.

As shown in the following table, the voltage drop per Unit depends on the total current consumption from the I/O power supply.

Total current consumption from the I/O power supply	Voltage drop per Unit
4 A	0.08 V
3 A	0.06 V
2 A	0.04 V
1 A	0.02 V

The following is a calculation example of the I/O power supply range applicable to the additional I/O power supply unit that is located on the right side of CPU Unit based on a unit configuration example shown below. You can also use the same calculation procedure to calculate the I/O power supply range after you add more I/O power supply units in addition to the first one.

Example:

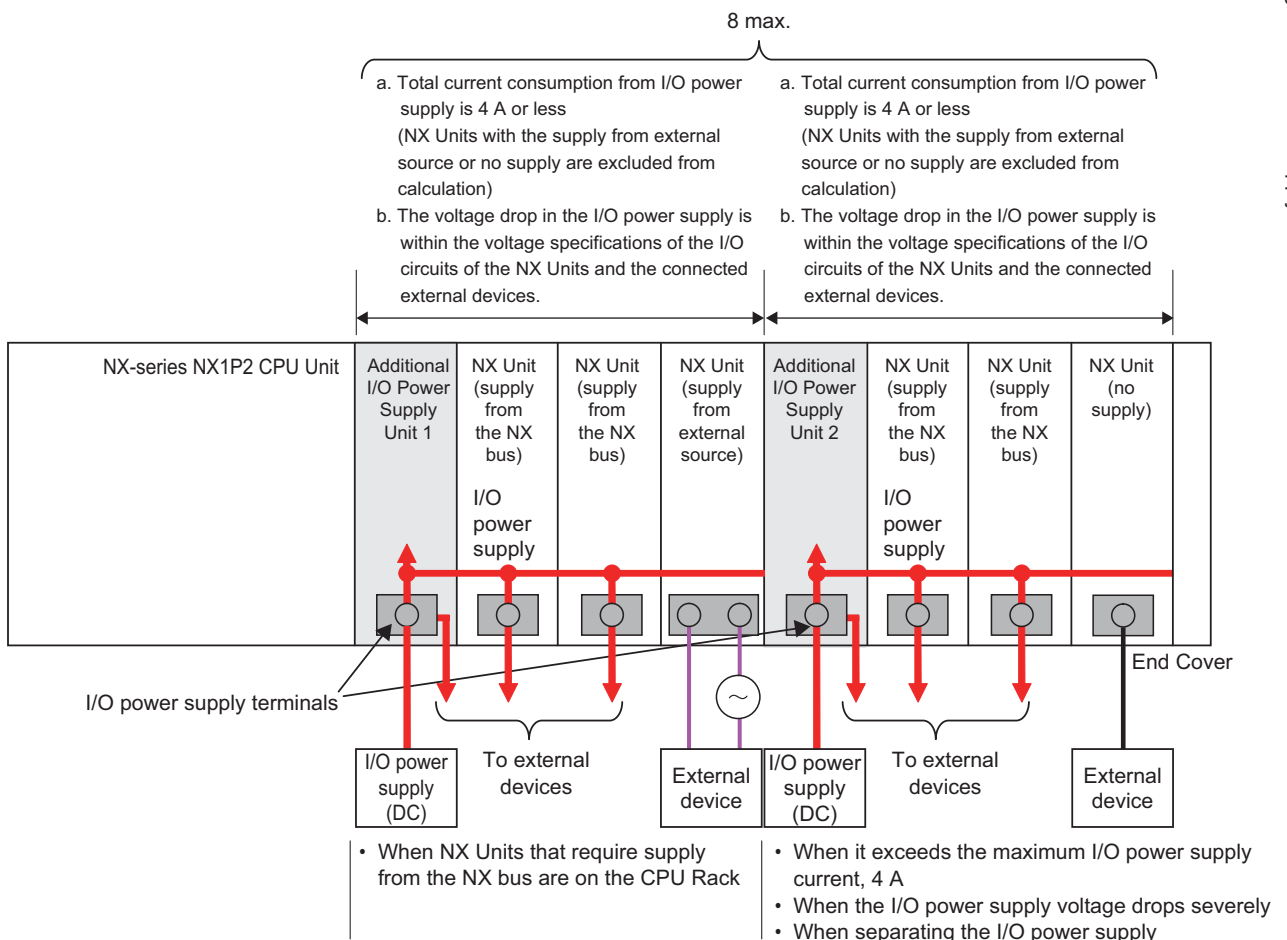

*1. The current consumption of the Additional I/O Power Supply Unit is not actually 0 A. However, a value of 0 A is used in this calculation example.

In actual calculations, add the current consumption from the I/O power supply that is given in *the NX-series Data Reference Manual* (Cat. No. W525).

● Outline

Find the I/O power supply voltage of the NX Unit that is the farthest from the Additional I/O Power Supply Unit 1. In this example, the I/O power supply voltage of Unit (5) is found.

● Conditions

Assume that an I/O power supply voltage of 24.00 VDC is supplied to the I/O power supply terminals on the Additional I/O Power Supply Unit 1.

● Procedure

1 Use the following formula to calculate the total current consumption from the I/O power supply.

$\begin{aligned} \text{Total current consumption from the I/O power supply} &= (1) + (2) + (3) + (4) + (5) \\ &= 0.0 \text{ A} + 0.5 \text{ A} + 0.5 \text{ A} + 0.0 \text{ A} + 2.0 \text{ A} \\ &= 3 \text{ A} \end{aligned}$

2 Find the I/O power supply voltage and make sure that it is within the voltage specifications of the I/O circuits of the NX Units and the connected external devices.

$\begin{aligned} \text{I/O power supply voltage at (5)} &= \text{I/O power supply voltage on I/O power supply terminals} - \text{Voltage drop per} \\ &\quad \text{Unit} \times \text{Number of Units passed through} \\ &= 24.00 \text{ V} - 0.06 \text{ V} \times (5 - 1 \text{ Units}) \\ &= 23.76 \text{ V} \end{aligned}$
--

Design to Separate the I/O Power Supply

If the I/O power supply voltages of the connected external devices are different, connect an Additional I/O Power Supply Unit at the point where the I/O power supply voltage changes and then perform similar calculations to design a system that meets the power supply conditions. The same method is used to separate the power supply systems. Connect an Additional I/O Power Supply Unit at the point where the power supply systems to be separated and then perform similar calculations to design the overall system to meet the power supply conditions.

4-3-3 Designing the I/O Power Supply from External Sources

Unlike supplying power from the NX bus, there is no specific design method for supplying I/O power from external sources.

Calculate the total current consumption from the I/O power supply for the NX Units to be supplied power from an external source.

Refer to the user's manuals of the NX Units for the total current consumption from the I/O power supply.

4-3-4 Designing I/O Power Supply for the Built-in I/O

The I/O power supply for built-in I/O is separated from NX bus, so there is no specific design method. Calculate the total power consumption from the I/O power supply provided from an external source. For the PNP (sourcing) type built-in output, an external source is required to supply power between the common terminal and 0 V terminal in order to drive the internal circuits. When you calculate, include this power supply used to drive, too.

Refer to *Input Specifications* on page 3-14 and *Output Specifications* on page 3-17 under *3-1-4 Terminal Blocks* on page 3-12 for the I/O specifications of the built-in I/O.

4-3-5 Restrictions on Inrush Current for ON/OFF Operation

This section describes the restrictions on inrush current from the I/O power supply that occurs when connected external devices turn ON and OFF.

Inrush Current Restrictions

If inrush current to the I/O power supply occurs when a connected external device turns ON or OFF, do not allow the effective value of the I/O power supply current to exceed the following rated values when the inrush current is added to the current consumption from the I/O power supply.

- Maximum I/O power supply current
- Current capacity of power supply terminals for the I/O power supply

Also, maintain the peak inrush current 20 A maximum and maintain the pulse width 1 s maximum.

Refer to 4-4-3 *Selecting Protective Devices* on page 4-22 for the rated values of the items when the CPU Rack is used.

Calculating the Effective Value of the I/O Power Supply Current

The formula to calculate the effective value of the I/O power supply current, I_{rms} , is given below.

$$I_{rms} = \sqrt{I_p^2 \times D + I_a^2 \times (1-D)}$$

$$(D = \tau/T)$$

- I_p : Peak inrush current (A)
- I_{rms} : Effective value of I/O power supply current (A)
- I_a : Total current consumption from the I/O power supply (A)
- D : Inrush current duty
- τ : Inrush current pulse width (s)
- T : Inrush current period (s)

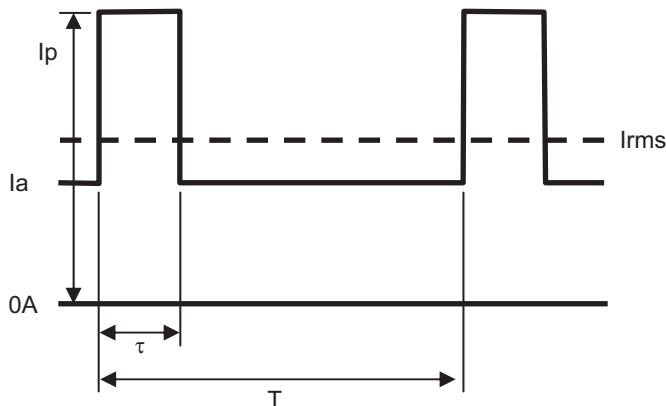

4-4 Selecting External Power Supplies and Protective Devices

This section describes how to select the Unit power supply and the I/O power supply which are the external power supplies for the CPU Rack, and how to select the protective devices.

4-4-1 Selecting the Unit Power Supply

This section describes how to select the Unit power supply for the CPU Rack.

Recommended Power Supplies

Use an SELV power supply that meets the following conditions for the Unit power supply.

- Has overcurrent protection.
- Has double or reinforced insulation between the input and output.
- Has an output voltage of 24 VDC (20.4 to 28.8 VDC).

Recommended Power Supplies: S8VK-S Series (manufactured by OMRON)

Calculating the Required Power Supply Capacity of the Unit Power Supply

● Formula

This section describes how to calculate the required capacity of the Unit power supply for the CPU Rack.

Required capacity of the Unit power supply for the CPU Rack	=	Total of required Unit power supply capacity for each block
---	---	---

Use the following formula to calculate the required Unit power supply capacity for each block in the CPU Rack.

Required Unit power supply capacity of the CPU Unit block = (A) + (B)/(C)

Required Unit power supply capacity of an Additional NX Unit Power Supply Unit block = ((D) + (E))/(F)

(A)	Unit power consumption of the CPU Unit
(B)	Total NX Unit power consumption of NX Units that are connected to the CPU Unit
(C)	NX Unit power supply efficiency of the CPU Unit
(D)	NX Unit power consumption of the Additional NX Unit Power Supply Unit
(E)	Total NX Unit power consumption of NX Units that are connected to the Additional NX Unit Power Supply Unit
(F)	NX Unit power supply efficiency of the Additional NX Unit Power Supply Unit

● **Blocks**

A block consists of the Unit that supplies the NX Unit power and the range of Units to which that Unit supplies the NX Unit power. For example, in the configuration in the following figure there are two blocks in the CPU Rack: the block with the CPU Unit and the block with the Additional NX Unit Power Supply Unit.

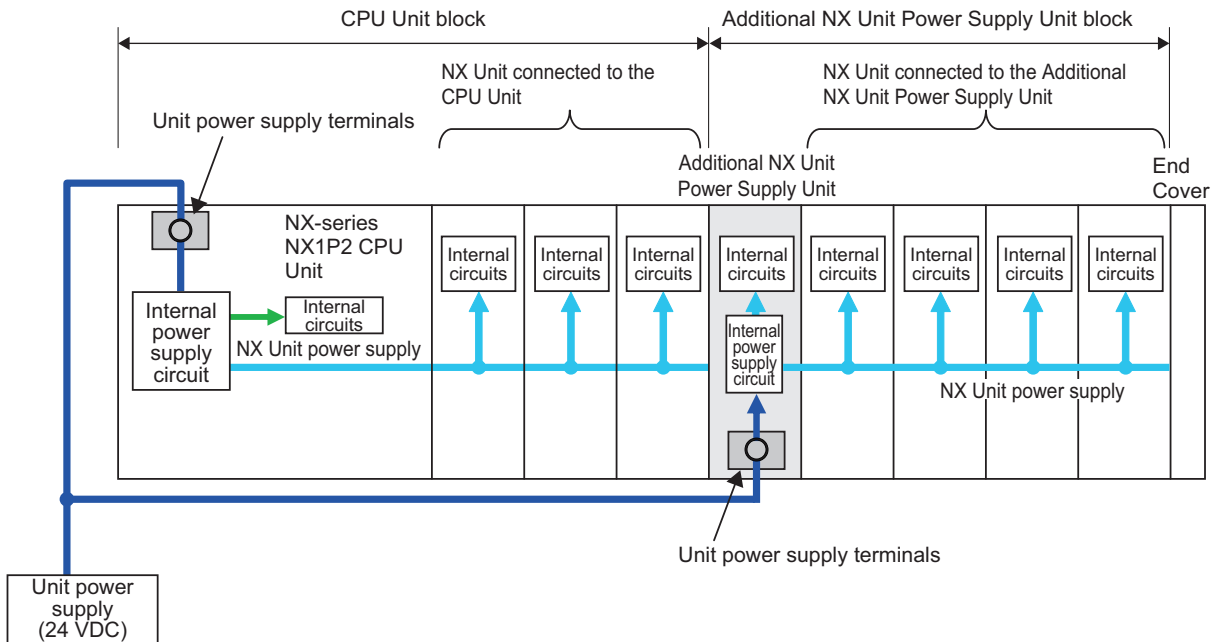

The total of the required Unit power supply capacity for these two blocks is the required power supply capacity of the Unit power supply for the CPU Rack.



Precautions for Correct Use

Use the same Unit power supply to supply the Unit power to one CPU Rack. If you supply power from different Unit power supplies, differences in electrical potential may cause unexpected currents in the NX Unit power supply, which may result in failure or malfunction.

● **Calculation Example**

This section provides a calculation example for the configuration example that is given in 4-2-2 *Calculation Example for the NX Unit Power Supply* on page 4-8.

Name	Model	Quantity	Power consumption/Unit
CPU Unit	NX1P2-1140DT	1	7.05 W
Additional I/O Power Supply Unit	NX-PF0630	1	0.85 W
Digital Input Unit	NX-ID3317	4	0.90 W
Relay Output Unit	NX-OC2633	3	1.20 W

- The NX Unit power supply efficiency of the CPU Unit is 80%.

In this configuration example, there is only one block, the CPU Unit block.

Required power supply capacity of Unit power supply to CPU Rack

= Required Unit power supply capacity of CPU Unit block

$$\begin{aligned}
 &= (\text{CPU Unit power consumption} + \text{Total power consumption from NX Unit power supply of NX Units connected to CPU Unit}) / \text{NX Unit power supply efficiency of CPU Unit} \\
 &= 7.05 \text{ W} + (0.85 \text{ W} \times 1 + 0.90 \text{ W} \times 4 + 1.20 \text{ W} \times 3) / 0.8 \\
 &= \text{Approx. } 17.1 \text{ W}
 \end{aligned}$$

The above is the constant power consumption during operation. When you select the power supply, consider the inrush current that will flow when the power is turned ON.

Refer to *Electrical and Mechanical Specifications* on page 3-3 under 3-1-1 Models and Specifications on page 3-2 for information on inrush current specifications.



Precautions for Safe Use

Select an external power supply with sufficient capacity by considering the power supply capacity or inrush current when the power is turned ON. Otherwise, the external power supply may not be turned ON or it may malfunction due to unstable voltage.

4-4-2 Selecting the I/O Power Supplies

This section describes how to select the I/O power supplies for the CPU Rack.

Recommended Power Supplies

Use an SELV power supply that meets the following conditions for the I/O power supply.

- Has overcurrent protection.
- Has double or reinforced insulation between the input and output.
- Has an output voltage of 5 to 24 VDC (4.5 to 28.8 VDC).*1

*1. Use an output voltage that is appropriate for the I/O circuits of the NX Units and the connected external devices.

Recommended Power Supplies: S8VK-S Series (manufactured by OMRON)

Calculating the Required Power Supply Capacity of the I/O Power Supply for NX Units

Use the calculation method that is described in 4-3-2 *Designing the I/O Power Supply from the NX Bus* on page 4-11 and calculate the total current consumption from the I/O power supply and the required power supply capacity of the I/O power supply.

Unlike the Unit power supply, it is not necessary to use only one I/O power supply to supply power to all NX Units on the CPU Rack.



Precautions for Safe Use

Select an external power supply with sufficient capacity by considering the power supply capacity or inrush current when the power is turned ON. Otherwise, the external power supply may not be turned ON or it may malfunction due to unstable voltage.

4-4-3 Selecting Protective Devices

This section describes how to select protective devices (e.g., breakers and fuses) to protect against short circuits and overcurrents in external circuits.

Overcurrent is the current that flows when an excessive load is connected and one of the following ratings is exceeded.

Unit	Item for rating	Rated value
CPU Unit	NX Unit power supply capacity	10 W max.
	Current capacity of power supply terminal	4 A max.
Additional NX Unit Power Supply Unit	NX Unit power supply capacity	Refer to <i>the NX-series System Units User's Manual</i> (Cat. No. W523).
	Current capacity of power supply terminal	
Additional I/O Power Supply Unit	Maximum I/O power supply current	4 A max*1.
	Current capacity of I/O power supply terminals	

*1. Even if the model of the Additional I/O Power Supply Unit you use allows the maximum I/O power supply current or current capacity of the I/O power supply terminals which is greater than 4 A, the I/O power must be supplied at 4 A or less because of the restriction on the CPU Rack system configuration.

The built-in I/O overcurrent refers to a current that flows when the maximum switching capacity of the built-in output is exceeded.



Precautions for Safe Use

Use the I/O power supply current for the CPU Rack of the NX1P2 CPU Unit at 4 A or less. Using the currents that are outside of the specifications may cause failure or damage.

Selecting Protective Devices

Consider the following items when you select protective devices.

- Protective device specifications (breaking/fusing, detection characteristics, steady current value, etc.)
- Inrush current when power is turned ON
- Inrush current when connected external devices turn ON and OFF*1

*1. Refer to *4-3-5 Restrictions on Inrush Current for ON/OFF Operation* on page 4-18 for information on the inrush current when connected external devices are turned ON and OFF.

For the breaking/fusing time, use protective devices that meet the conditions in the following table.

● For Unit Power Supply

Current	Breaking/fusing time
6 A	1 min max.
12 A	15 s max.
21 A	5 s max.
30 A	2.5 s max.

● For I/O Power Supply

Current	Breaking/fusing time
6 A	1 min max.
12 A	15 s max.
21 A	5 s max.
30 A	2.5 s max.

Installation Locations for Protective Devices

Install protective devices for the Unit power supply and I/O power supply in the locations that are shown in the following figure.

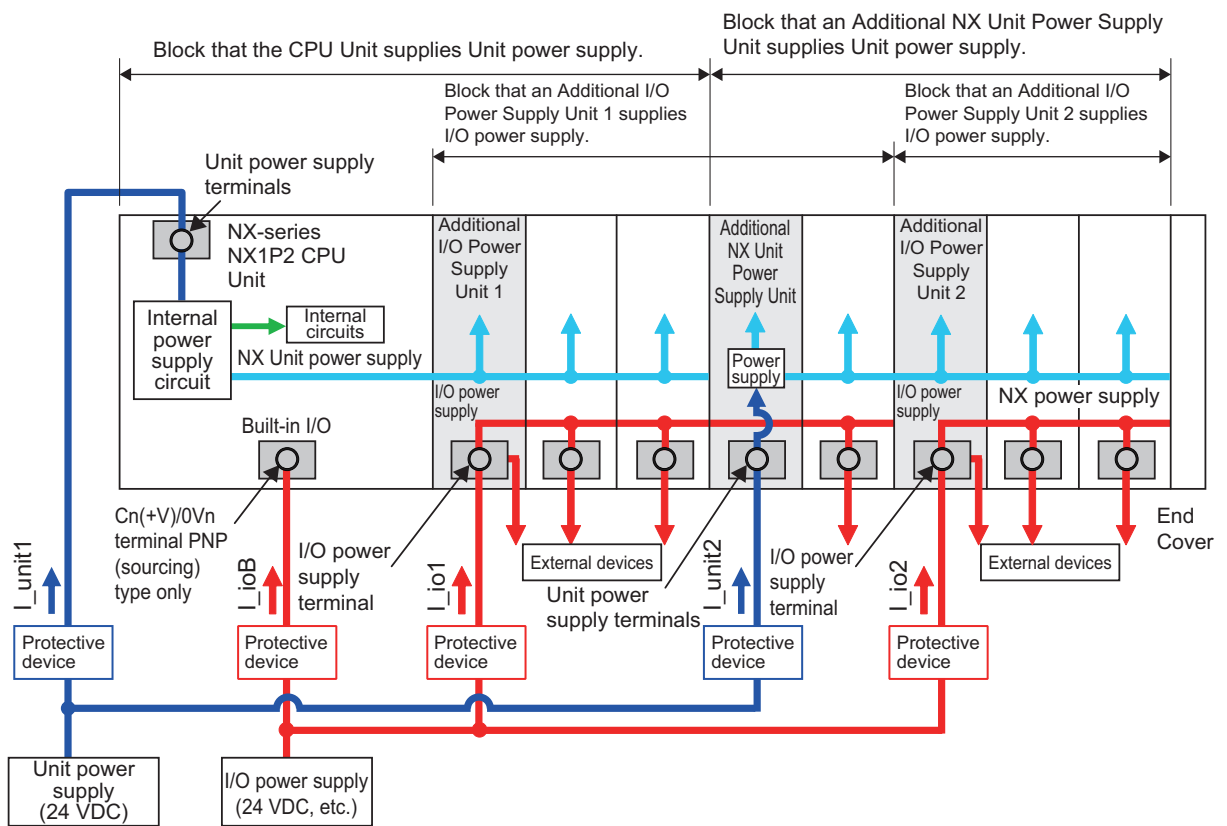

However, fewer protective devices may be required when the current consumption of each block does not exceed the rated current.

An example of this is provided below.

• Using Unwired Unit Power Supply Terminals

In this example, the current consumption from each power supply is as follows:

Current consumption from Unit power supply: $I_{unit1} + I_{unit2} \leq$ Lowest rated current

Current consumption from I/O power supply for NX Units: $I_{io1} + I_{io2} \geq 4$ A (rated current for I/O power supply)

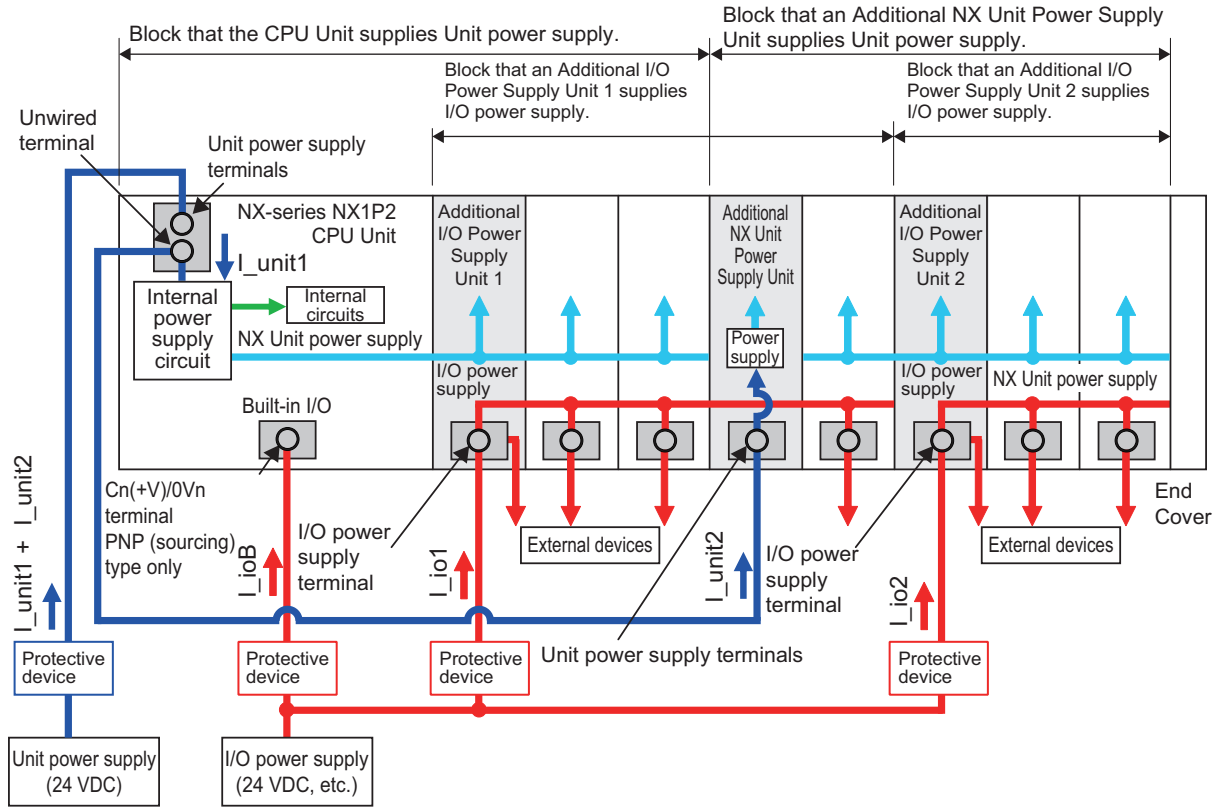

- When Total Current Consumption for All Blocks Does Not Exceed the Rated Current
 In this example, the current consumption from each power supply is as follows:
 Current consumption from Unit power supply: $I_{unit1} + I_{unit2} \leq$ Lowest rated current
 Current consumption from I/O power supply for NX Units: $I_{io1} + I_{io2} \leq 4$ A (rated current for I/O power supply)

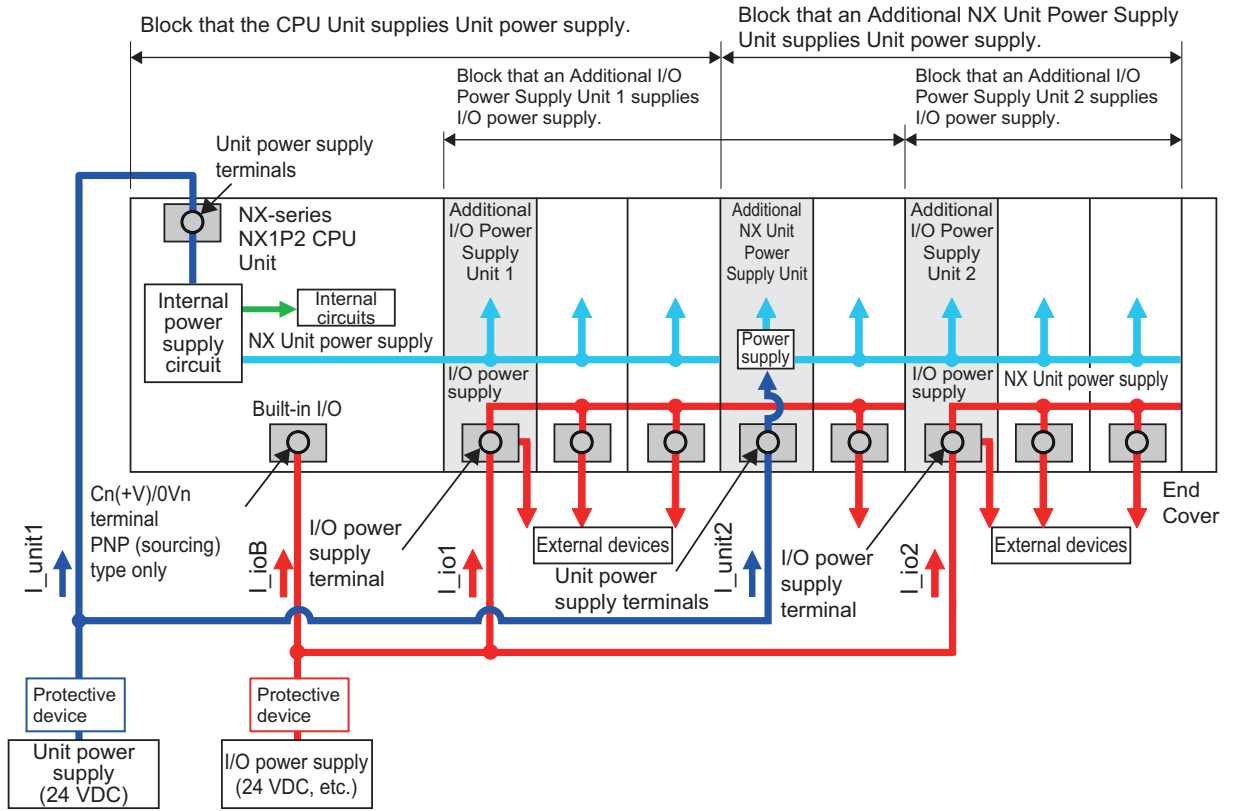

5

Installation and Wiring

This section describes how to install and wire the NX-series NX1P2 CPU Unit as well as details on installation locations.

5-1	Processing at Power ON and Power OFF	5-3
5-1-1	Power ON Operation	5-3
5-1-2	Power OFF Operation.....	5-5
5-1-3	Resetting the Controller from the Sysmac Studio.....	5-7
5-2	Fail-safe Circuits	5-8
5-3	Mounting Units	5-11
5-3-1	Installation in a Control Panel	5-12
5-3-2	Preparations for Installation	5-16
5-3-3	Installing the CPU Unit.....	5-18
5-3-4	Installing and Connecting NX Units	5-20
5-3-5	Mounting the End Cover	5-24
5-3-6	Mounting the End Plates.....	5-25
5-3-7	Attaching Markers.....	5-26
5-3-8	Installing and Removing the SD Memory Card.....	5-27
5-3-9	Attaching and Removing Option Boards.....	5-32
5-3-10	Battery Installation	5-33
5-3-11	Removing CPU Unit.....	5-36
5-3-12	Removing NX Units	5-37
5-3-13	Assembled Appearance and Dimensions.....	5-38
5-4	Wiring	5-42
5-4-1	Wiring the Unit Power Supply	5-43
5-4-2	Wiring the Additional NX Unit Power Supply Unit.....	5-43
5-4-3	Wiring the Additional I/O Power Supply Unit	5-43
5-4-4	Wiring the Protective Devices	5-43
5-4-5	Grounding	5-44
5-4-6	Wiring the Built-in EtherCAT Port.....	5-49
5-4-7	Wiring the Built-in EtherNet/IP Port	5-49
5-4-8	Wiring to the CPU Unit Terminal Block	5-49
5-4-9	Wiring the built-in I/O	5-63
5-4-10	Wiring the NX1W-CIF01 Serial Communications Option Board	5-67
5-4-11	Wiring the NX1W-CIF11/-CIF12 Serial Communications Option Board	5-72
5-4-12	Wiring the Analog I/O Option Board	5-75
5-5	Control Panel Installation	5-81
5-5-1	Temperature.....	5-81
5-5-2	Humidity	5-83
5-5-3	Vibration and Shock.....	5-83
5-5-4	Atmosphere	5-83

5-5-5	Electrical Environment	5-84
5-5-6	Grounding	5-88

5-1 Processing at Power ON and Power OFF

WARNING

- Do not touch the terminal section while power is ON. Electrical shock may occur.
- Do not disassemble any of the Units. Particularly the Units contain parts with high voltages when power is ON or immediately after power is turned OFF. Electrical shock may occur. There are also sharp internal parts that may cause injury.



5-1-1 Power ON Operation



Precautions for Safe Use

It takes approximately 20 seconds to enter RUN mode after the power supply is turned ON. During that time, digital outputs on the CPU Rack will be OFF. Note that the slave outputs will behave according to the setting value.

Use the system-defined variables and the NX Unit device variables in the user program to confirm that I/O data communications are established before attempting control operations. External communications are also not performed during startup.

Operation Until Operation Ready Status

Once the Unit power supply to the Unit power supply terminal starts, approximately 10 to 20 seconds elapses before the CPU Unit enters the operation-ready status. This period is called the *startup* status. The *startup* time depends on the slave/NX Unit configuration*1, user program, SD Memory Card usage, SD Memory Card self-diagnosis usage*2, etc.

While the CPU Unit is in the startup status, the RUN indicator flashes at a one second interval.

*1. Some EtherCAT slaves can set a maximum standby time of 1 to 200 seconds. For the CPU Unit, however, the operation-ready status exists as soon as the EtherCAT Master Function Module is functioning, regardless of the standby time of the EtherCAT slaves. For the EtherCAT Master Function Module, slaves that do not start within the maximum waiting time are treated as having an error.

*2. This function performs self-diagnosis on the inserted SD Memory Card. This is executed if the self-diagnosis at startup is enabled in the **Operation Settings** under **Configurations and Setup – Controller Setup** in the Sysmac Studio.

* This function performs self-diagnosis on the inserted SD Memory Card. This is executed if the self-diagnosis at startup is enabled in the **Operation Settings** under **Configurations and Setup – Controller Setup** in the Sysmac Studio.

The following processing is performed during the *startup* status of CPU Unit.

Process	Description
Self diagnosis at startup	Operation is monitored for the following errors: Power Supply Error, CPU Unit Reset, Hardware Initialization Error, and System Initialization Error. *1

Process	Description
Data check	The <i>_RetainFail</i> (Retention Failure Flag) system-defined variable changes to TRUE when the values of variables for which the Retain attribute was set to retain the values were not retained after a power interruption.
Recording Power Turned ON and Power Interrupted events	The Power Turned ON and Power Interrupted events are recorded.

*1. Refer to *NJ/NX-series Troubleshooting Manual (Cat. No. W503)* for information on the Power Supply Error, CPU Unit Error, Hardware Initialization Error, and System Initialization Error.

Operating Mode at Startup

The system will immediately enter RUN mode if RUN mode (default) is set as the startup operating mode. The system will immediately enter PROGRAM mode if PROGRAM mode is set as the startup operating mode.

- RUN Mode Set as Startup Mode

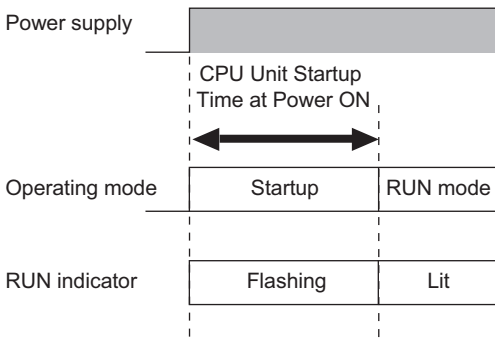

- PROGRAM Mode Set as Startup Mode

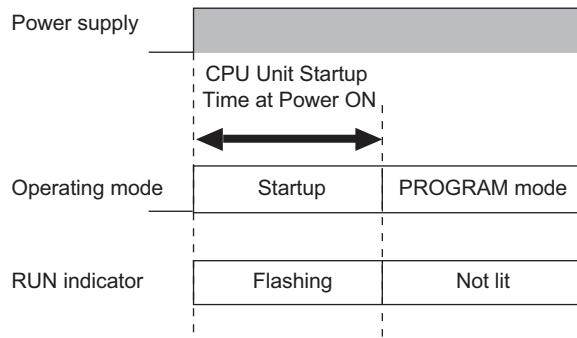

5-1-2 Power OFF Operation

WARNING

The NX-series Controller continues normal operation for a specific period of time even when a momentary power interruption occurs. The Controller may therefore receive incorrect signals from external devices that are affected by the momentary power interruption. Take suitable actions, such as external fail-safe measures and interlock conditions, to monitor the power supply voltage of the external devices as required.



A power OFF status is detected when the Unit power supply drops to the following voltage or lower or when the following time has elapsed due to a momentary power interruption.

Momentary power interruption voltage	Power OFF detection time
20.4 VDC or less	2 ms min.*1 to 8 ms max.

*1. A power OFF status may be detected when a momentary power interruption of 2 ms or less occurs consecutively.

Operation at Power OFF

Execution of the user program is ended if a power interruption exceeds the time shown in the table below. The processing after power interruption confirmation (described below) is performed, and then the system (i.e., CPU Unit) stops.

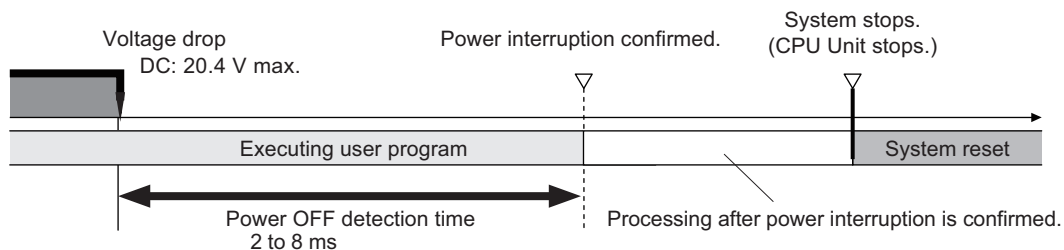

As shown in the following figure, the system (i.e. CPU Unit) will stop even if the voltage recovers after the power interruption detection time.

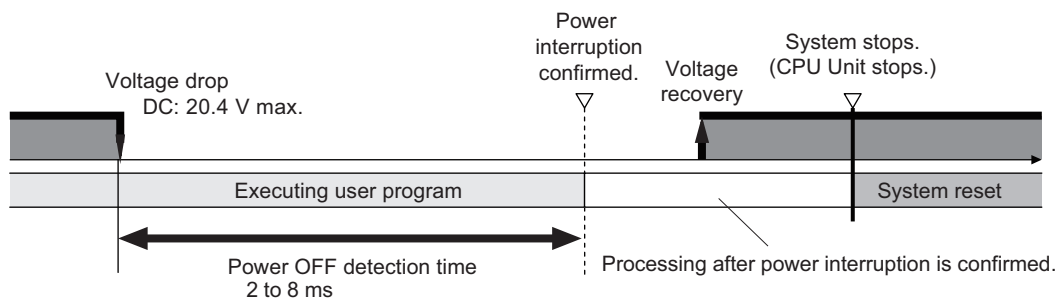

After stopping, the system will restart if the power supply remains recovery.

The table below defines the time that is used in the above two figures.

Item	Description
Power OFF detection time	The time from when the power supply voltage drops until the CPU Unit starts processing after the power interruption is confirmed. The CPU Unit continues to operate normally until the power interruption is confirmed.

Momentary Power Interruption with Continued Operation

Execution of the user program will continue if a momentary power interruption is less than the following times.

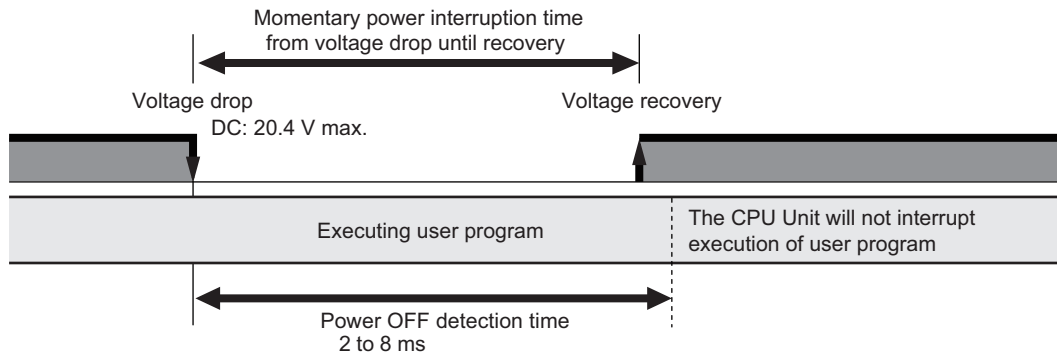

Processing after Power Interruption Is Confirmed

After a power interruption is confirmed, the CPU Unit performs the following processing and then stops.

Item		Description
I/O refresh		I/O refresh stops, and all outputs are turned OFF. Tag data links via the EtherNet/IP stop.
Processing	SD Memory Card access in progress	Any writing is interrupted, files are closed, and the Card is unmounted.
	Transferring user program (including online editing)	Interrupted. As a result, an error will occur the next time that the power is turned ON. The Controller will not operate.
	User program execution	User program execution is aborted even during execution of an instruction.
Saving event log		The time that a power interruption occurs and the cause (primary power interruption) of the interruption are recorded.

5-1-3 Resetting the Controller from the Sysmac Studio

You can reset the CPU Unit from the Sysmac Studio.

A reset from the Sysmac Studio follows the same operation as cycling the power supply of the Unit power.

Resetting is possible, however, only when the CPU Unit is in PROGRAM mode.

Confirm the following status before the CPU Unit Reset.

- Check the status of output loads.
- Make sure that SD Memory Card access is not in progress.

5-2 Fail-safe Circuits

WARNING

Provide safety measures in external circuits to ensure safety in the system if an abnormality occurs due to malfunction of the CPU Unit, slaves, or Units or due to other external factors affecting operation. Not doing so may result in serious accidents due to incorrect operation.

- Emergency stop circuits, interlock circuits, limit circuits, and similar safety measures must be provided in external control circuits.
- The outputs may remain ON or OFF due to deposition or burning of the output relays or destruction of the output transistors. As a countermeasure for such problems, external safety measures must be provided to ensure safe operation of the system.



WARNING

The CPU Unit will turn OFF digital outputs on the CPU Rack in the following cases.

- While the CPU Unit is on standby until RUN mode is entered after the power is turned ON
- If an error occurs in the power supply
- If a system initialization error occurs

Digital outputs on the CPU Rack will produce outputs according to the settings in the following cases.

- If a CPU Unit error or CPU Unit reset occurs
- If a major fault level Controller error occurs

External safety measures must be provided to ensure safe operation of the system in such cases.



WARNING

- If a communications interference occurs for remote I/O or if a major fault level error occurs, output status will be determined by the specifications of the external output device.

Confirm the operating specifications for communications errors and major fault level errors and implement suitable safety measures. Correctly set all of the settings in the slaves and Units.

- If external power supplies for Units, slaves or other devices are overloaded or short-circuited, the voltage will drop, outputs will turn OFF, and the system may be unable to read inputs. Provide external safety measures in controls with monitoring of external power supply voltage as required so that the system operates safely in such a case.
- Unintended outputs may be performed when an error occurs in variable memory. As a countermeasure for such problems, external safety measures must be provided to ensure safe operation of the system.
- Provide measures in the communications system and user program to ensure safety in the overall system even if errors or malfunctions occur in data link communications or remote I/O communications.
- You must implement fail-safe circuits to provide sufficient protection in the event that abnormal signals occur as the result of broken signal lines or momentary power interruptions.

Not doing so may result in serious accidents due to incorrect operation.



Order of Powering On and Off the Controller and Controlled System

Outputs from Units, such as DC Output Units, may malfunction momentarily when the Unit power supply is turned ON. This may cause problems in the system if the Unit power supply is turned ON after the I/O power supply (i.e. controlled system's power supply) is turned ON. To prevent possible malfunctions, configure an external circuit that prevents the power supply to the controlled system from turning ON before the power supply to the Controller itself.

Also, the external circuit must be configured so that the Unit power supply turns OFF only after the power supply to the controlled system has turned OFF.



Precautions for Safe Use

It takes approximately 20 seconds to enter RUN mode after the power supply is turned ON. During that time, digital outputs on the CPU Rack will be OFF. The slave outputs behave according to the setting values. Use the system-defined variables and the NX Unit device variables in the user program to confirm that I/O data communications are established before attempting control operations. External communications are also not performed during startup.

Order of Powering Off the Controller and Controlled System

If you turn OFF the Unit power supply before turning OFF the I/O power supply, which is supplied to the control system, the output terminals on the DC Output Unit or other Units may malfunction and the control system may be temporarily unable to perform normal output operation. In order to prevent such errors, the external circuits should be configured to turn OFF the Unit power supply after the power supply to the control system is turned OFF.

Failure of the Built-in Output or Output Section of the Output Unit

It is possible for an output to remain ON due to a malfunction in the internal circuit of the built-in output or output section of the Output Unit, such as a relay or transistor malfunction. Be sure to add any circuits necessary outside of the Controller to ensure the safety of the system in the event that an output section fails to go OFF.

Interlock Circuits

When the Controller controls an operation such as the clockwise and counterclockwise operation of a motor, provide an external interlock such as the one shown in the following example to prevent both the forward and reverse outputs from turning ON at the same time if required by the application.

Example:

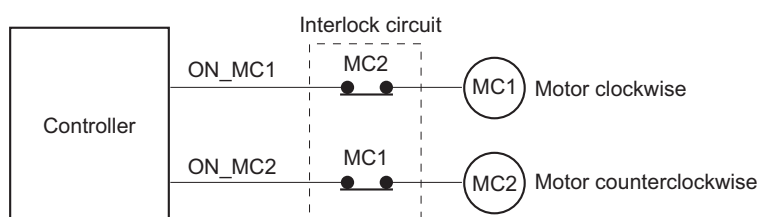

This circuit prevents outputs MC1 and MC2 from both being ON at the same time even if both Controller outputs ON_MC1 and ON_MC2 are ON due to a malfunction.

5-3 Mounting Units

This section describes how to mount Units to the NX-series Controller.



Precautions for Safe Use

Always turn OFF the power supply to the Controller before you attempt any of the following.

- Mounting or removing NX Units or CPU Unit
- Assembling the Units
- Setting DIP switches or rotary switches
- Connecting cables or wiring the system
- Connecting or disconnecting the terminal blocks or connectors
- Mounting or removing the Option Board

The built-in power supply of the CPU Unit may continue to supply power after the power supply is turned OFF. The POWER indicator remains lit as long as power is supplied. Make sure that the POWER indicator is not lit before you perform any of the above operations.



Precautions for Correct Use

- Follow the instructions in this manual to correctly perform installation.
 - Do not operate or store the Units in the following locations. Doing so may result in burning, in operation stopping, or in malfunction.
 - Locations subject to direct sunlight
 - Locations subject to temperatures or humidity outside the range specified in the specifications
 - Locations subject to condensation as the result of severe changes in temperature
 - Locations subject to corrosive or flammable gases
 - Locations subject to dust (especially iron dust) or salts
 - Locations subject to exposure to water, oil, or chemicals
 - Locations subject to shock or vibration
 - Take appropriate and sufficient countermeasures during installation in the following locations.
 - Locations subject to strong, high-frequency noise
 - Locations subject to static electricity or other forms of noise
 - Locations subject to strong electromagnetic fields
 - Locations subject to possible exposure to radioactivity
 - Locations close to power lines
-

5-3-1 Installation in a Control Panel

Installation in Cabinets or Control Panels

When the NX-series Controller is being installed in a cabinet or control panel, be sure to provide proper ambient conditions as well as access for operation and maintenance.

● Temperature Control

The ambient temperature within the NX-series Controller must be within the operating range of 0 to 55°C. When necessary, take the following steps to maintain the proper temperature.

- Provide enough space for good air flow.
- Do not install the Controller directly above equipment that generates a large amount of heat such as heaters, transformers, or high-capacity resistors.
- If the ambient temperature exceeds 55°C, install a cooling fan or air conditioner.

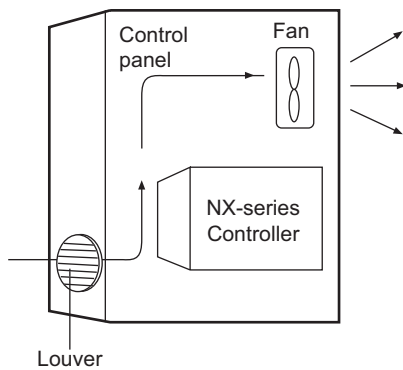

● Accessibility for Operation and Maintenance

- To ensure safe access for operation and maintenance, separate the Controller as much as possible from high-voltage equipment and power machinery.
- It will be easy to operate the Controller if it is mounted at a height of 1.0 to 1.6 m above the floor.

● Improving Noise Resistance

- Do not mount the Controller in a control panel containing high-voltage equipment.
- Install the Controller at least 200 mm away from power lines.

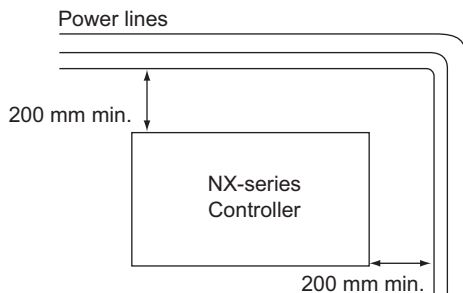

- Ground the mounting plate between the Controller and the mounting surface.

● **Controller Orientation**

- Each Rack must be mounted in the following position to provide proper cooling. This position is called an upright position.

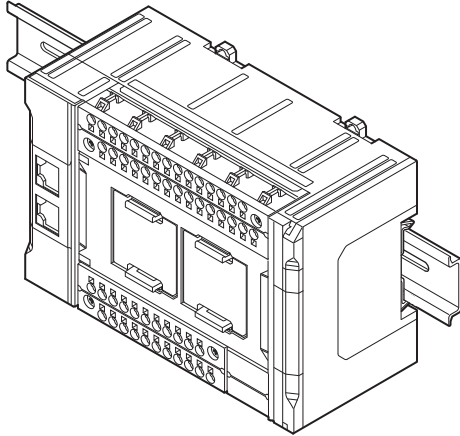

- Do not install a Rack in any of the following positions.

Mounting with the DIN Track on the Bottom

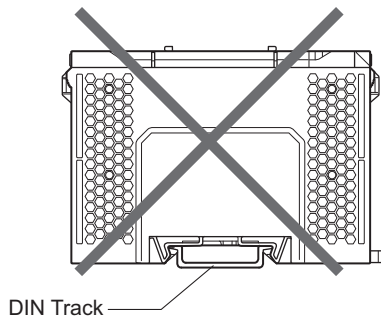

Mounting with the DIN Track on the Top

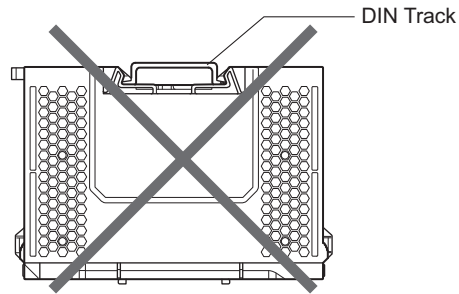

Mounting with the Rack Upside down

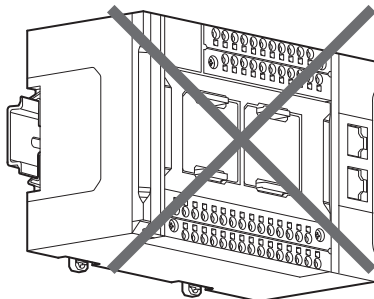

Mounting with the DIN Track Installed Vertically

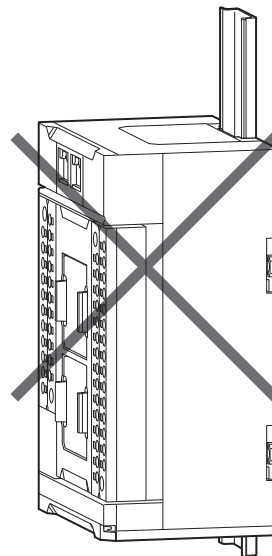

Installation Method in Control Panels

An NX-series Controller must be mounted inside a control panel on DIN Track.

- Consider the width of wiring ducts, wiring, ventilation, and Unit replacement when determining the space between the CPU Rack and other devices.



Additional Information

A Controller must be mounted on DIN Track.
It cannot be mounted with screws.

● Wiring Ducts

Whenever possible, route I/O wiring through wiring ducts.

Install mounting bracket so that it is easy to fish wire through the duct. It is handy to have the duct at the same height as the CPU Rack.

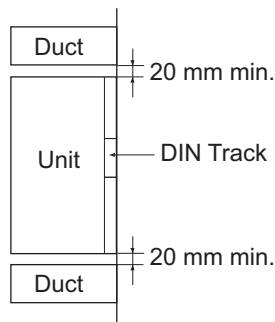

● Wiring Duct Example

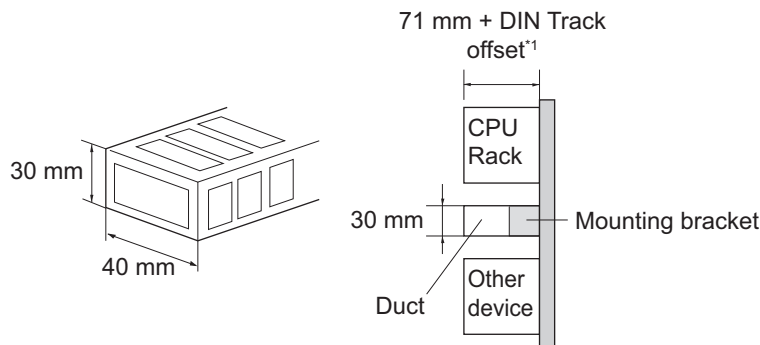

*1. It varies depending on the DIN Track to be used. Refer to *Installation Dimensions* on page 5-38 under 5-3-13 *Assembled Appearance and Dimensions* on page 5-38 for details. It corresponds to the dimension (B).

● Routing Wiring Ducts

Install the wiring ducts at least 20 mm away from the tops of the Rack and any other objects (e.g., ceiling, wiring ducts, structural supports, devices, etc.) to provide enough space for air circulation and replacement of Units.

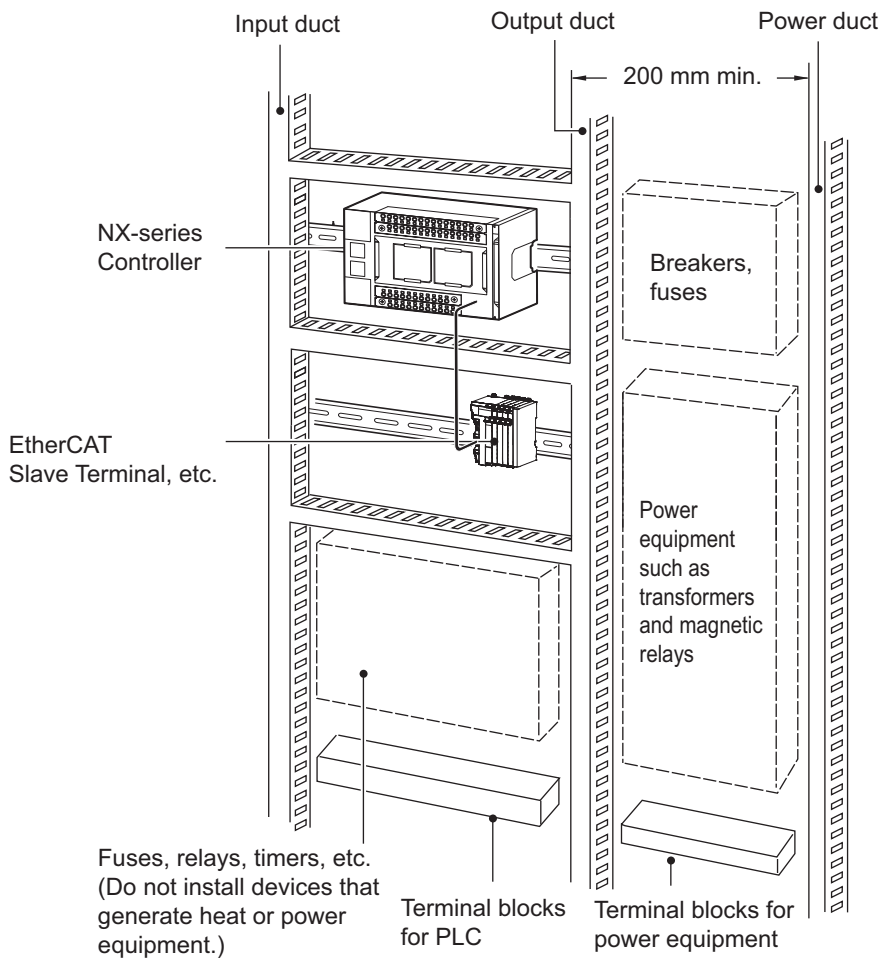

5-3-2 Preparations for Installation

We recommend using the following products to install the Unit on a DIN Track.

Name	Model	Manufacturer	Remarks
35-mm DIN Track	PFP-50N	OMRON Corporation	<ul style="list-style-type: none"> Length: 50 cm Material: Aluminum Surface treatment: Insulated
	PFP-100N	OMRON Corporation	<ul style="list-style-type: none"> Length: 100 cm Material: Aluminum Surface treatment: Insulated
	NS 35/ 7,5 PERF	Phoenix Contact	<ul style="list-style-type: none"> Length: 75.5, 95.5, 115.5, or 200 cm Material: Steel Surface treatment: Conductive
	NS 35/ 15 PERF	Phoenix Contact	<ul style="list-style-type: none"> Length: 75.5, 95.5, 115.5, or 200 cm Material: Steel Surface treatment: Conductive
End Plate	PFP-M	OMRON Corporation	Two End Plates are required for each CPU Rack.
	CLIPFIX 35	Phoenix Contact	Two End Plates are required for each CPU Rack.

Not all of the combinations of the DIN Tracks and End Plates listed above are possible.

Confirm applicability of the combinations in the following table.

DIN Track model	PFP-M (OMRON)	CLIPFIX 35 (Phoenix Contact)
PFP-50N	Possible	Possible
PFP-100N	Possible	Possible
NS 35/ 7,5 PERF	Possible	Possible
NS 35/ 15 PERF	Not possible	Possible

Also, use screws and washers of the following sizes to fix the DIN Tracks.

(a): Dimensions from the screw head to the fastening surface

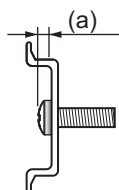

DIN Track model	Applicable screw size	(a)
PFP-50N	M4	4.1 mm max.
NS 35/ 7,5 PERF	M6	4.6 mm max.
NS 35/ 15 PERF	M6	10 mm max.

If you use any DIN Track other than those listed in the table above, refer to the dimensions shown in 5-3-13 *Assembled Appearance and Dimensions* on page 5-38 and use proper screws and washers.

● DIN Tracks

PFP-100N/50N DIN Track

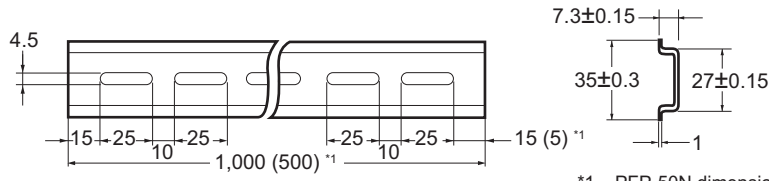

*1. PFP-50N dimensions are given in parentheses.

NS 35/ 7,5 PERF

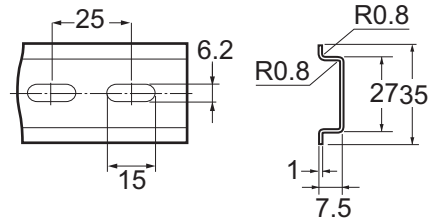

NS 35/ 15 PERF

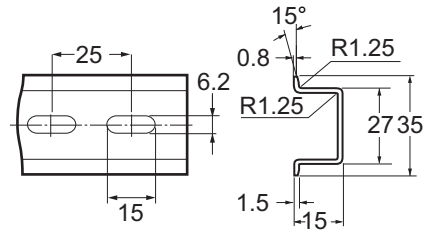

● **End Plate**

PFP-M (Two)

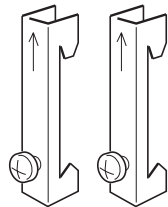

CLIPFIX 35 (Two)

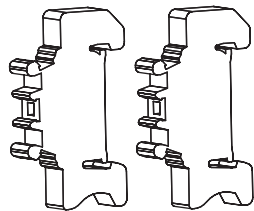

5-3-3 Installing the CPU Unit

This section describes how to install the CPU Unit.



Precautions for Safe Use

- Do not apply labels or tape to the Unit. When the Unit is installed or removed, adhesive or scraps may adhere to the pins in the NX bus connector, which may result in malfunctions.
- Do not touch the pins in the NX bus connector on the Unit. Dirt may adhere to the pins in the NX bus connector, which may result in malfunctions.

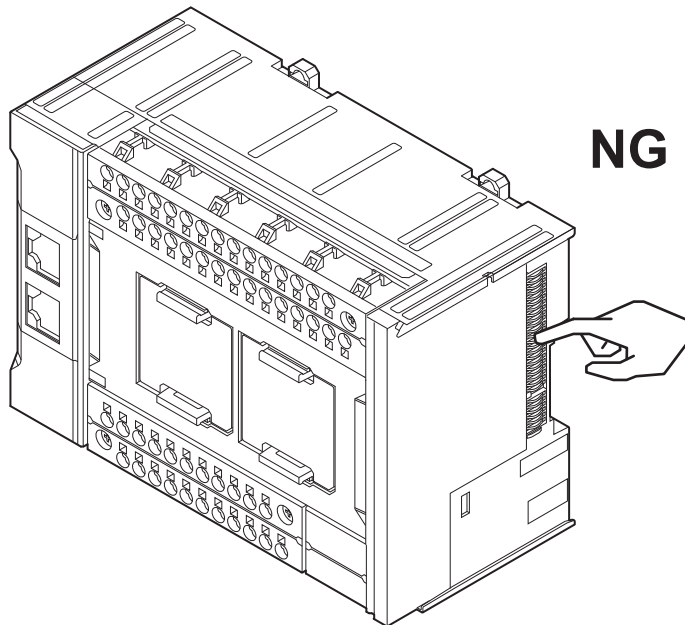

- Do not write anything with ink within the restricted region of the CPU Unit that is shown in the following figure. Also do not get this area dirty. When the Unit is installed or removed, ink or dirt may adhere to the pins in the NX connector, which may result in malfunctions in the Unit. Refer to the user's manual for the connected NX Unit for information on the restricted region for the NX Unit.

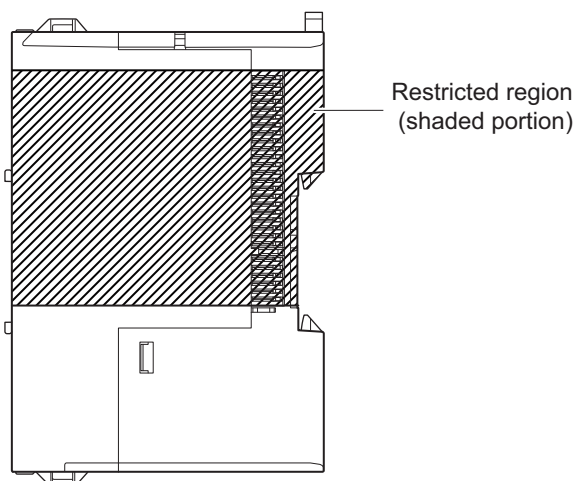



Precautions for Correct Use

- When you install the Unit, be careful not to touch or bump the pins in the NX bus connector.
- When you handle the Unit, be careful not to apply stress to the pins in the NX bus connector. If the Unit is installed and the power supply is turned ON when the pins in the NX bus connector are deformed, contact failure may cause malfunctions.

1 Install the DIN Track.

- Using a PFP-50N/100N DIN Track

Use one M4 screw for each three holes in the DIN Track. There must be a screw for each interval of 105 mm or less. The screw tightening torque is 1.2 N·m.

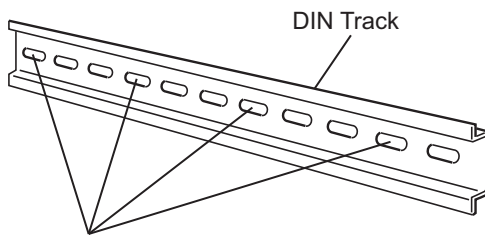

Use one screw for each three holes.

- Using an NS 35/7,5 PERF or NS 35/15 PERF DIN Track

Use one M6 screw for each four holes in the DIN Track. There must be a screw for each interval of 100 mm or less. The screw tightening torque is 5.2 N·m.

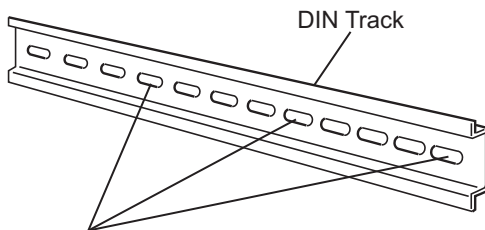

Use one screw for each four holes.

2 Make sure that the DIN Track mounting hook on the CPU Unit is in the unlock position.

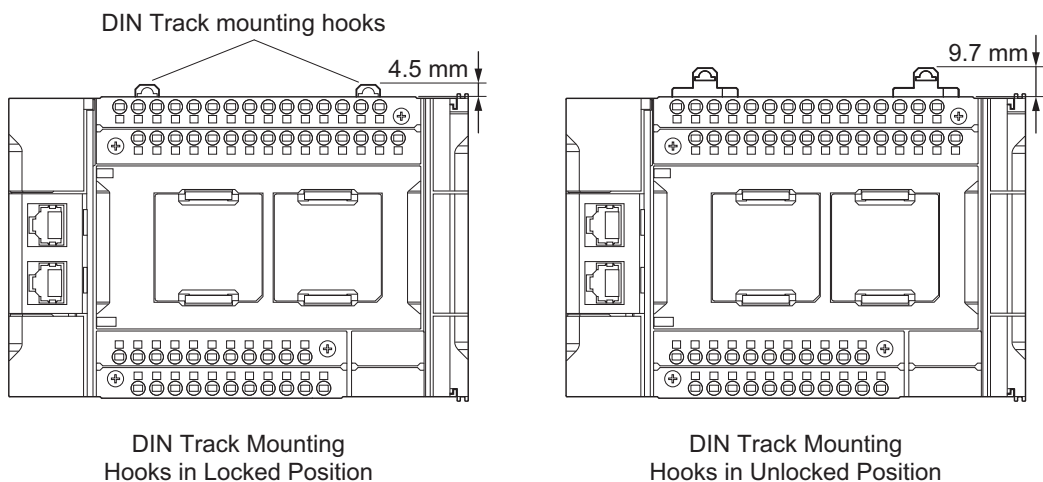

If the DIN Track mounting hooks are pulled up, they are in the unlocked position.

If the DIN Track mounting hooks are pressed down, they are in the locked position.

Use a flat-blade screwdriver to pull up the DIN Track mounting hook on the Unit to release the locked position.

- 3** Press the CPU Unit straight against the DIN Track.

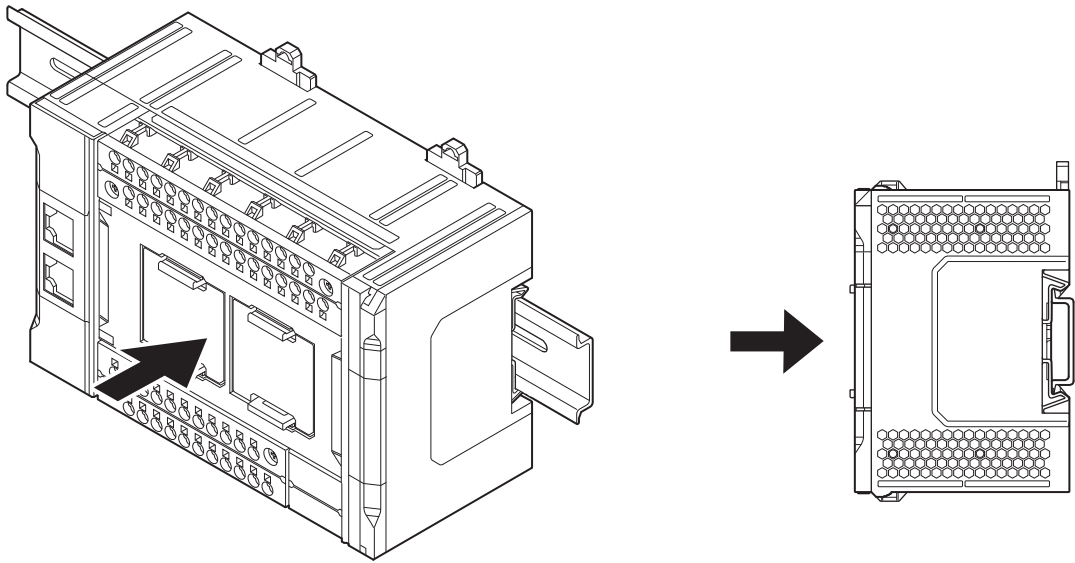

- 4** Press the DIN Track mounting hooks down to the locked position.
After mounting, make sure that the CPU Unit and the End Cover are securely mounted on the DIN Track.

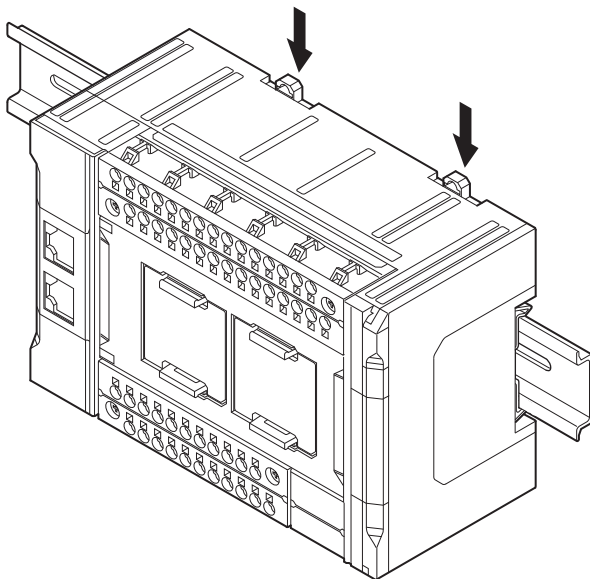

5-3-4 Installing and Connecting NX Units

This section describes how to mount NX Units to the CPU Unit and how to connect NX Units to each other.

Markers can be attached to NX Units and their terminal blocks to identify them. To make NX Units identifiable, attach markers before you install the NX Units. Refer to *5-3-7 Attaching Markers* on page 5-26 for details on how to attach markers.



Precautions for Safe Use

- Always turn OFF the power supply before mounting the NX Units. If the power supply is not OFF, the Unit may malfunction or may be damaged.
- Do not apply labels or tape to the Units. When the Units are installed or removed, adhesive or scraps may adhere to the pins in the NX bus connector, which may result in malfunctions.
- Do not touch the pins in the NX bus connector on the Unit. Dirt may adhere to the pins in the NX bus connector, which may result in malfunctions.

NG

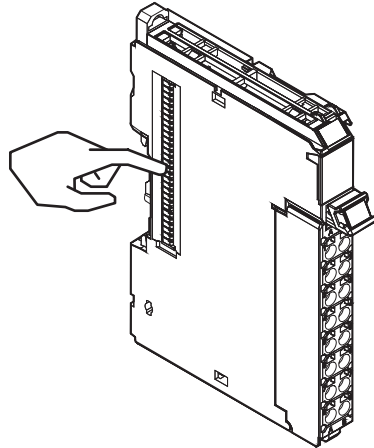

NG

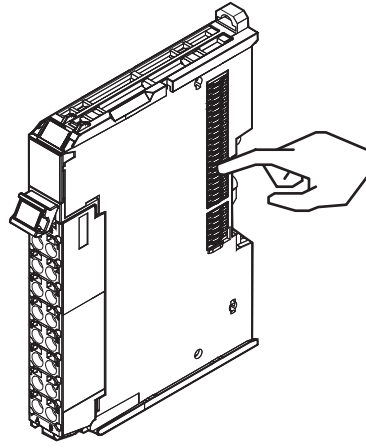

Example: NX Unit (12 mm width)

- Do not write on an NX Unit with ink within the restricted region that is shown in the following figure. Also do not get this area dirty. When the Unit is installed or removed, ink or dirt may adhere to the pins in the NX bus connector, which may result in malfunctions in the CPU Rack.

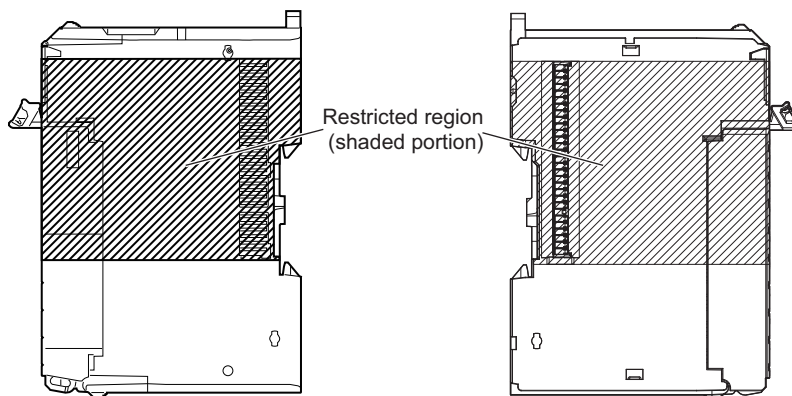

Precautions for Correct Use

- When you mount an NX Unit to the CPU Unit or when you connect NX Units to each other, always mount the Units one at a time on the DIN Track. If you connect NX Units to each other and attempt to mount them together to the DIN Track at the same time, the Units may separate from each other and fall.
- When you handle a Unit, be careful not to apply stress to the pins in the NX bus connector. If the Unit is installed and the power supply is turned ON when the pins in the NX bus connector are deformed, contact failure may cause malfunctions.
- When you handle a Unit, be careful not to touch or bump the pins in the NX bus connector.

● Mounting NX Unit to CPU Unit

Mount the NX Unit to the CPU Unit after removing the End Cover.

- 1 From the front of the CPU Unit, engage the Unit hookup guides on the NX Unit with the Unit hookup guides on the Communication Control Unit.

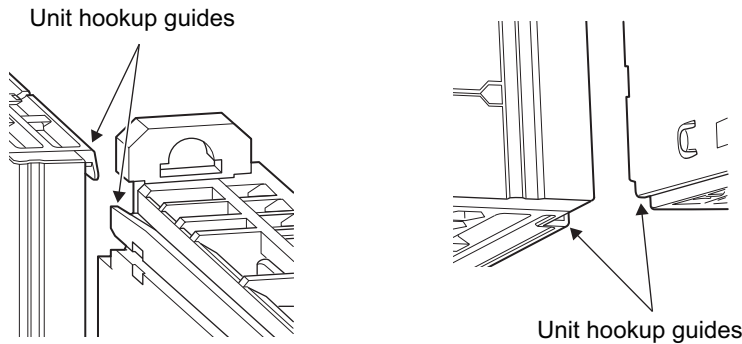

- 2 Slide the NX Unit on the hookup guides.

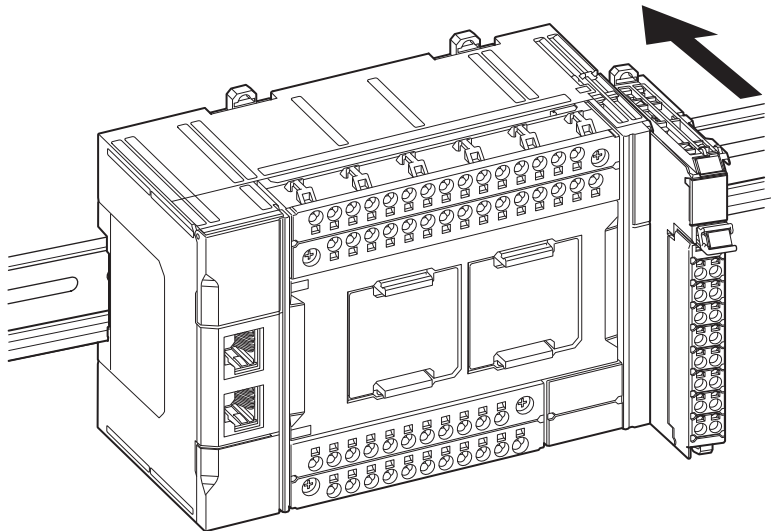

- 3 Press the NX Unit with a certain amount of force against the DIN Track until you hear the DIN Track mounting hook lock into place.

When you mount the NX Unit, it is not necessary to release the DIN Track mounting hook on the NX Unit. After you mount the NX Unit, make sure that it is locked to the DIN Track.



Additional Information

It is not normally necessary to unlock the DIN Track mounting hook when you mount the NX Unit. However, if you mount the NX Unit on a DIN Track that is not one of the recommended DIN Tracks, the DIN Track mounting hook may not lock properly. If that happens, unlock the DIN Track mounting hook at the start of the procedure, mount the NX Unit to the DIN Track, and then lock the DIN Track mounting hook.

● Mounting NX Units to Each Other

Use the following procedure to mount NX Units to each other.

- 1 From the front of the previously mounted NX Unit, engage the Unit hookup guides on a new Unit with the Unit hookup guides on the previously mounted NX Unit.

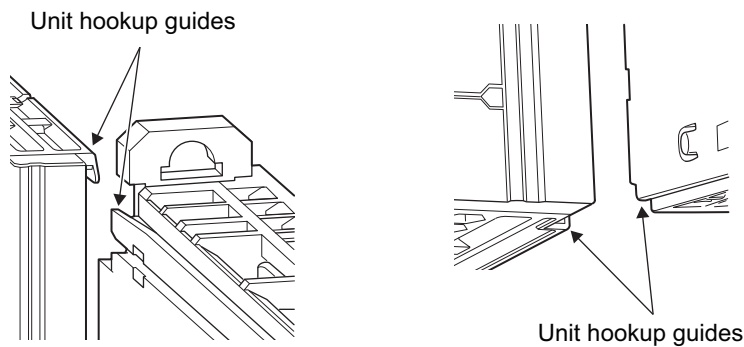

- 2 Slide the NX Unit on the hookup guides.

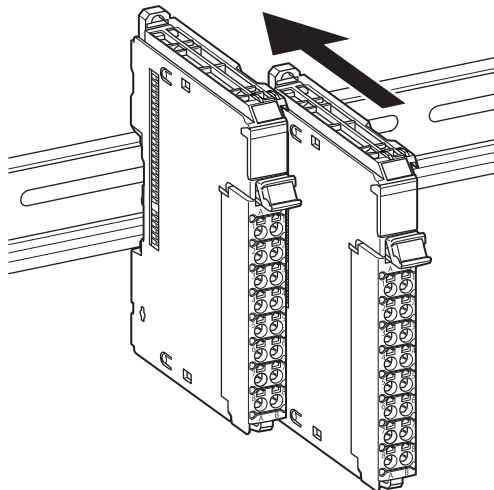

- 3 Press the NX Unit with a certain amount of force against the DIN Track until you hear the DIN Track mounting hook lock into place.

When you mount the NX Unit, it is not necessary to release the DIN Track mounting hook on the NX Unit.

After you mount the NX Unit, make sure that it is locked to the DIN Track.



Additional Information

It is not normally necessary to unlock the DIN Track mounting hook when you mount the NX Unit. However, if you mount the NX Unit on a DIN Track that is not one of the recommended DIN Tracks, the DIN Track mounting hook may not lock properly. If that happens, unlock the DIN Track mounting hook at the start of the procedure, mount the NX Unit to the DIN Track, and then lock the DIN Track mounting hook.

5-3-5 Mounting the End Cover

Always mount the End Cover (NX-END02) provided with the product to the end of the CPU Rack.



Precautions for Safe Use

The End Cover has a metal portion and is heavier than it looks. Be careful not to drop it when handling.



Precautions for Correct Use

Always mount an End Cover to the end of the CPU Rack to protect the last Unit on the CPU Rack. Not mounting the End Cover may result in malfunction or failure of the CPU Unit.

- 1** From the front of the rightmost Unit, slide the End Cover along the Unit hookup guides on the rightmost Unit on the CPU Rack.

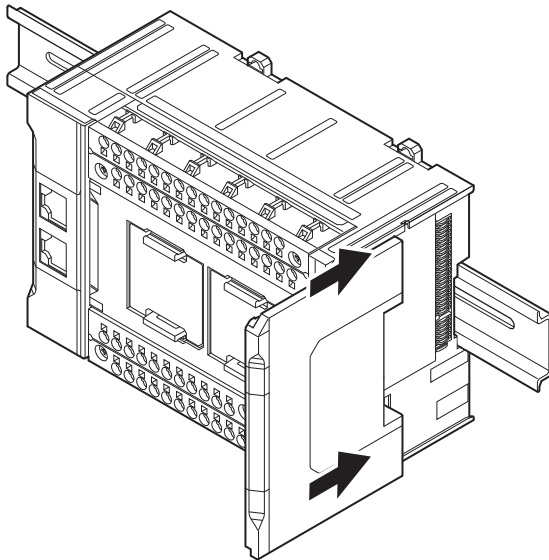

- 2** Press the End Cover firmly against the DIN Track until you hear it lock into place on the DIN Track.
After you mount the End Cover, make sure that it is securely mounted on the DIN Track.

5-3-6 Mounting the End Plates

After you mount the End Cover, always secure the Unit with End Plates at both sides.



Precautions for Correct Use

After you mount the Unit on the DIN Track, always secure it with End Plates at both sides. If you do not secure it, the Unit may be damaged or malfunction.

● Using PFP-M (OMRON)

To mount an End Plate, 1) hook the bottom of it on the bottom of the DIN Track and 2) rotate the End Plate to hook the top of it on the top of the DIN Track.

Then tighten the screw to lock the End Plate in place.

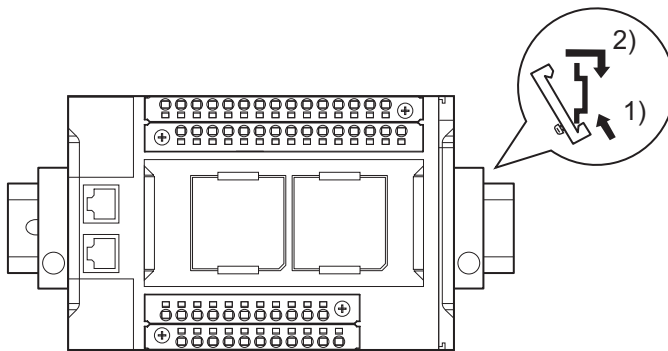

● Using CLIPFIX 35 (Phoenix Contact)

To mount an End Plate, 1) hook the top of it on the top of the DIN Track and 2) rotate the Plate to hook the bottom of it on the bottom of the DIN Track. Press in until you hear the End Plate lock into place.

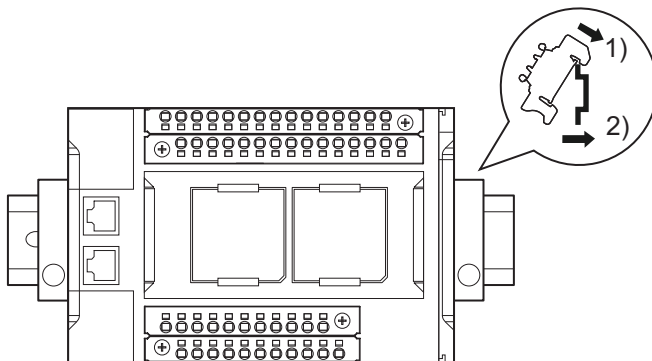

To remove an End Plate 1) insert the tip of a flat-blade screwdriver into groove "a" and 2) use "b" as a fulcrum and lift the end of the screwdriver, as shown in the following diagram.

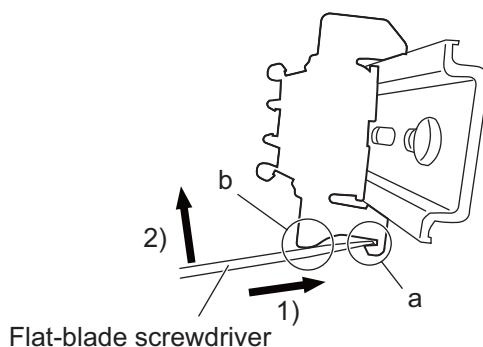

5-3-7 Attaching Markers

Markers can be attached to NX Units and their terminal blocks to identify them.

The plastic markers made by OMRON are installed for the factory setting. The ID information can be written on them.

Commercially available markers can also be installed.

Replace the markers made by OMRON if you use commercially available markers now.

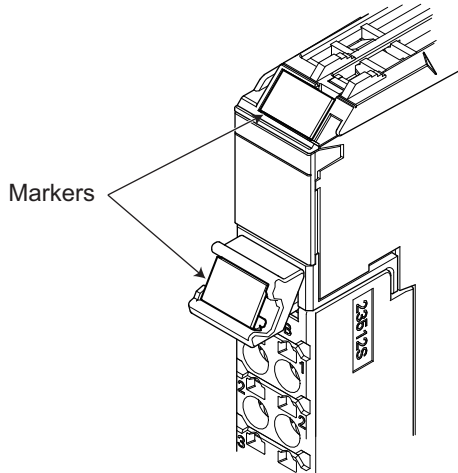

The marker attachment locations on the NX Units depend on the type of external connection terminals. Refer to the user's manual for the NX Units that you will use for the marker attachment locations.

● Installation Method

Insert the protrusions on the markers into the marker attachment locations on the NX Units and terminal blocks on NX Units.

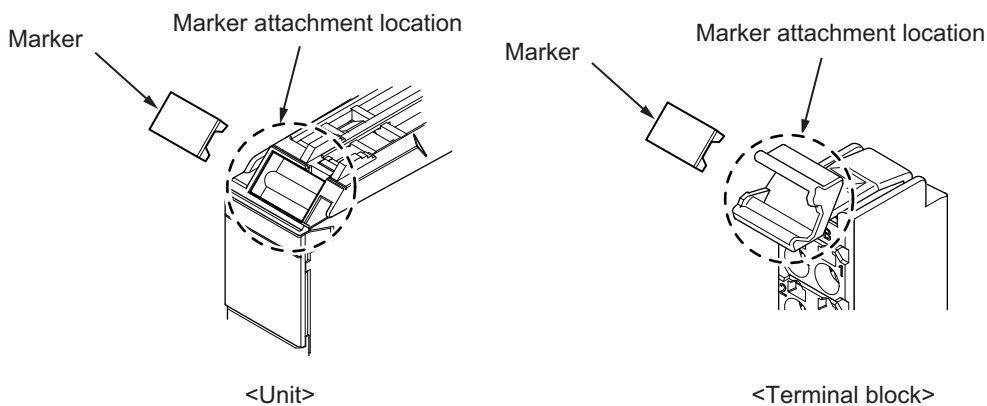

● Commercially Available Markers

Commercially available markers are made of plastic and can be printed on with a special printer.

To use commercially available markers, purchase the following products.

Product name	Model number	
	Manufactured by Phoenix Contact	Manufactured by Weidmuller
Markers	UC1-TMF8	DEK 5/8
Special marker printer	UM EN BLUEMARK X1	PrintJet PRO

The markers made by OMRON cannot be printed on with commercially available special printers.

5-3-8 Installing and Removing the SD Memory Card

Before Using an SD Memory Card

- Keep the following precautions because an SD Memory Card may become unusable.
 - a) Do not turn OFF the power supply to the Controller while the SD BUSY indicator is lit (i.e., while SD Memory Card access is in progress).
The SD BUSY indicator is lit when the SD Memory Card is accessed from the user program or from a computer through FTP.
 - b) Do not remove the SD Memory Card while the SD BUSY indicator is lit or the SD PWR indicator is lit (i.e., while SD Memory Card power is supplied).
Press the SD Memory Card power supply switch and confirm that the SD BUSY indicator or SD PWR indicator is not lit before you remove the SD Memory Card.
- Never insert the SD Memory Card facing the wrong way.
If the SD Memory Card is inserted forcibly, it may become unusable.
- To format the SD Memory Card (e.g., to delete all of the data), insert the SD Memory Card in the CPU Unit and perform the operation from the Sysmac Studio.
- The SD Memory Card uses flash memory, and so its service life is limited. When the end of the SD Memory Card's service life approaches, the ability to write data is lost, and data is sometimes not retained after writing. The service life depends on the size of the data that is written and on the ambient temperature. For the unlikely event that data is lost, it is recommended to periodically back up data.
- The service life may be extremely short if a non-OMRON SD Memory Card is used. Also, operation may be affected due to deterioration in writing performance.
- If you use an OMRON SD Memory Card, the end of the life of the SD Memory Card can be detected in the following ways.
 - a) `_Card1Deteriorated` (SD Memory Card Life Warning Flag) system-defined variable
 - b) *SD Memory Card Life Exceeded* event in the event log

Installing the SD Memory Card

- 1 Use a tool such as a flat-blade screwdriver and lift up the memory card cover placed in the upper-left corner of CPU Unit.

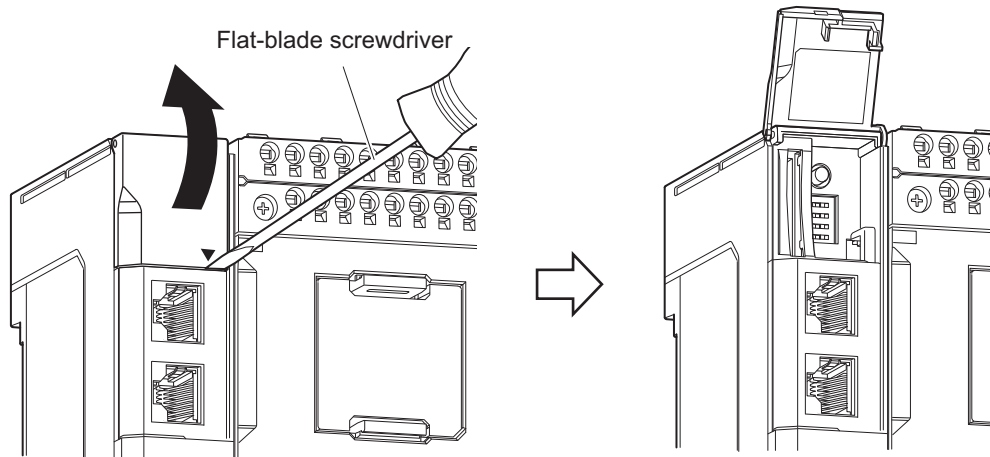

- 2 Insert the SD Memory Card with the label facing to the left.
Insert the SD Memory Card with the label facing the left side of CPU Unit.

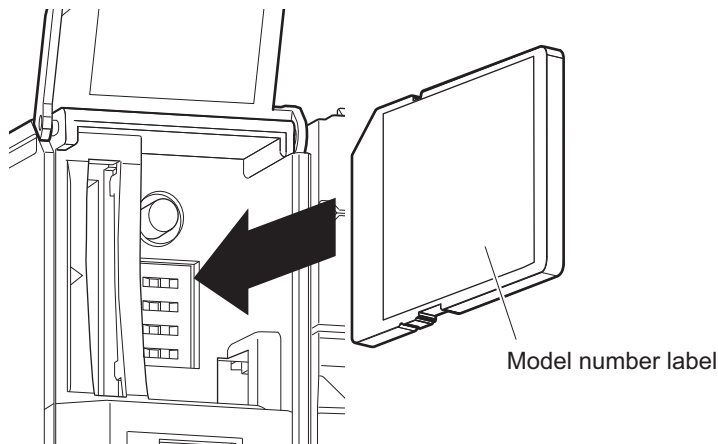

- 3 Push the SD Memory Card securely into the compartment.

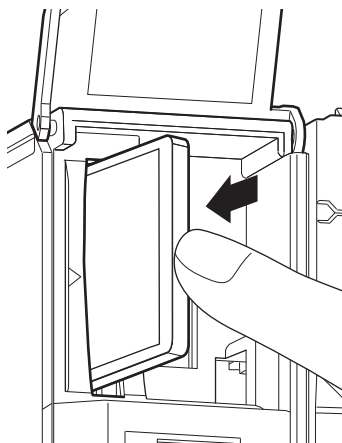

- 4 Close the Memory Card cover.

Removing the SD Memory Card

- 1 Press the SD Memory Card power supply switch.

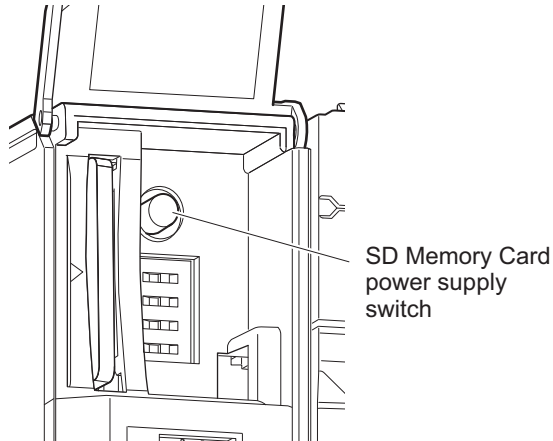

- 2 Press the SD Memory Card after you confirm that the SD BUSY indicator (lit while SD Memory Card access is in progress) and SD PWR indicator (lit while SD Memory Card power is supplied) are no longer lit.

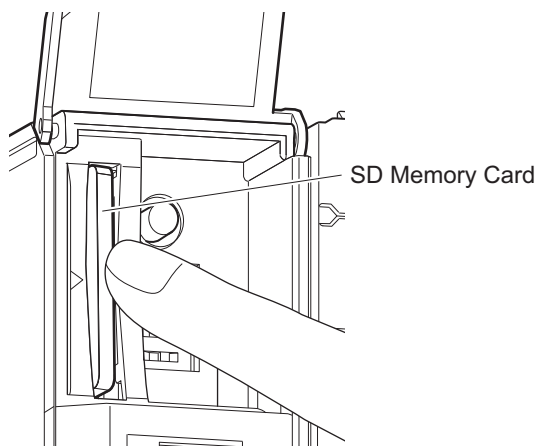

The SD Memory Card will be ejected from the compartment.

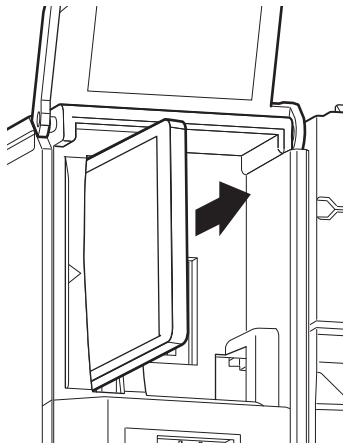

- 3 Pull out the SD Memory Card.

- 4 Close the Memory Card cover.

5-3-9 Attaching and Removing Option Boards

The following describes how to attach and remove Option Boards to and from the CPU Unit.



Precautions for Safe Use

Turn OFF the Controller's power supply before you attach or remove an Option Board. Not doing so may cause unintended operation of the CPU Unit or Option Board.

When you attach an Option Board, you need to remove the cover of any option board slot on the CPU Unit. Hold the upper and lower lock levers of the cover between the fingertips at the same time to unlock and remove it. Align the notch of the Option Board with that of the option board slot and press the Option Board into the slot until it clicks.

When you remove the Option Board, hold the lock levers of the Option Board between the fingertips and pull it straight out. After removal, reinstall the cover on the CPU Unit.

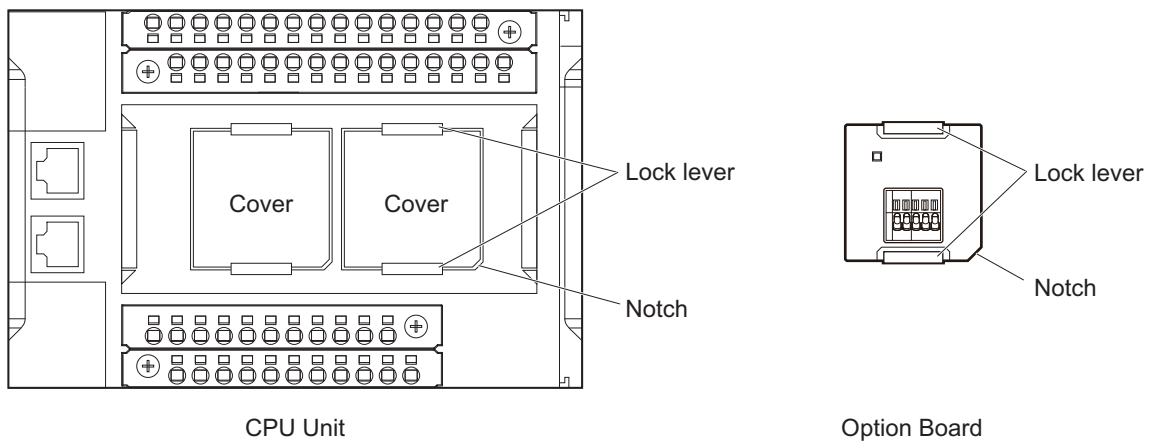

5-3-10 Battery Installation

Battery to Use

Use the Battery CJ1W-BAT01 which is sold separately.



Precautions for Correct Use

Be sure to install a Battery within two years of the production date shown on the Battery label.
Production Date



Manufactured in March 2018.

Battery Installation Procedure

Use the following procedure to install the Battery.



Precautions for Safe Use

We recommend mounting or replacing the Battery with the power turned OFF to prevent the CPU Unit's sensitive internal components from being damaged by static electricity and to prevent malfunctions. The Battery can be mounted or replaced without turning OFF the power supply. To do so, always touch a grounded piece of metal to discharge static electricity from your body before starting the procedure.

If the Low Battery Voltage error occurs after you mount the Battery, connect the Sysmac Studio and clear the error.



Additional Information

UL standards require that batteries be installed or replaced by experienced technicians. Always place an experienced technician in charge of the procedure.

- 1** Turn OFF the power supply to the Controller.
If the CPU Unit has not been ON, turn it ON for at least five minutes and then turn it OFF.
- 2** Using a flat-blade screwdriver, remove the battery cover on the lower left corner of the CPU Unit.

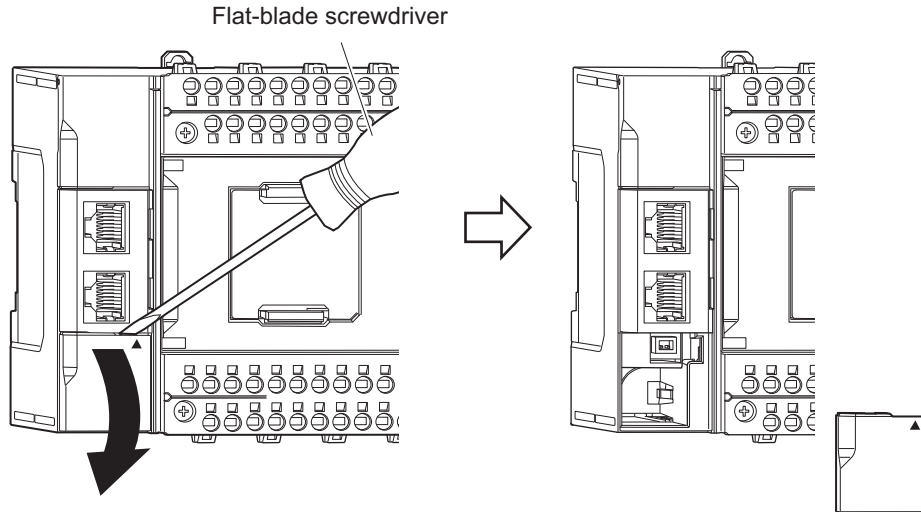

Precautions for Correct Use

The battery cover will come off. Be careful not to allow the cover to fall and get lost during removal.

- 3 Connect the connector of the battery to the battery connector and insert the battery in the battery slot.

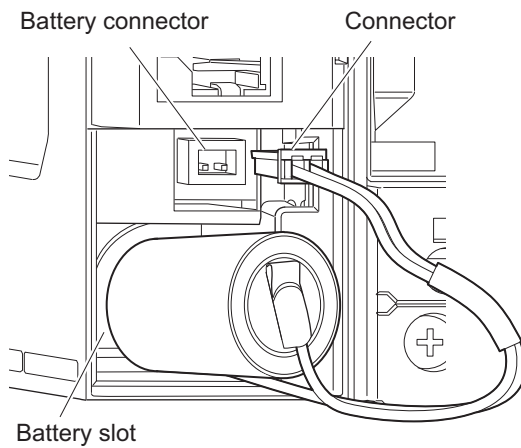

- 4 Press in the battery harness and attach the battery cover.

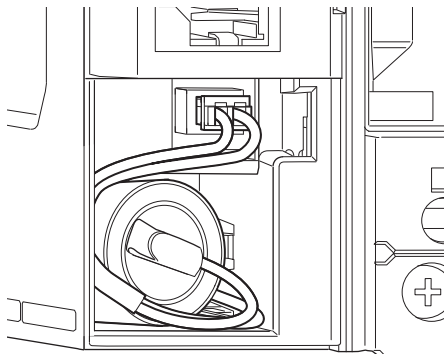

- 5 Set the **Battery-related error detection** to **Use** and adjust the CPU Unit's clock data to the current time.

Refer to the *Sysmac Studio Version 1 Operation Manual (Cat. No. W504)* for how to make the setting.



Precautions for Safe Use

- Never short-circuit the battery terminals; never charge the battery; never disassemble the battery; and never heat or incinerate the battery. Doing any of these may cause the battery to leak, heat, ignite, or rupture.
 - Dispose of any battery that has been dropped on the floor or otherwise subjected to excessive shock. Batteries that have been subjected to shock may leak if they are used.
-

5-3-11 Removing CPU Unit

This section describes how to remove the CPU Unit.



Precautions for Correct Use

When you remove a Unit, be careful not to touch or bump the pins in the NX bus connector.

- 1** Unlock the DIN Track mounting hook.
Use a flat-blade screwdriver to pull up the DIN Track mounting hook to unlocked position.
At this point, be sure not to drop the CPU Unit.

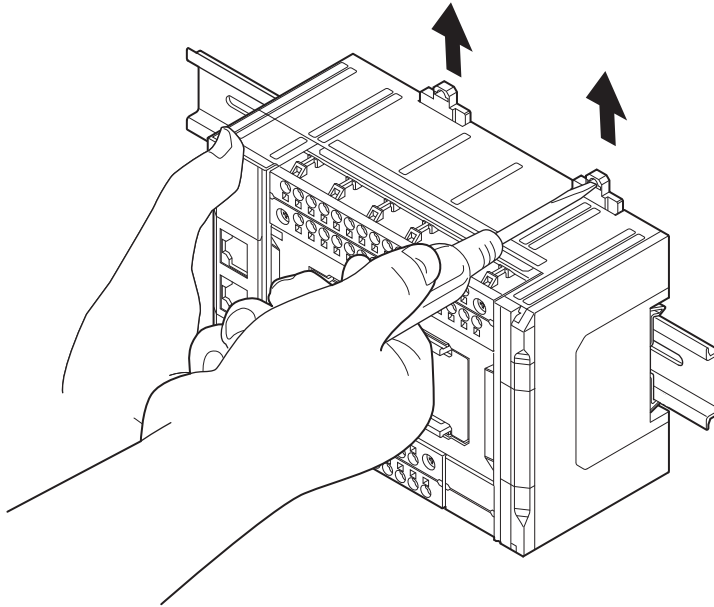

- 2** Remove the CPU Unit from the DIN Track.
Pull the Unit straight forward to remove. Be careful not to drop it.

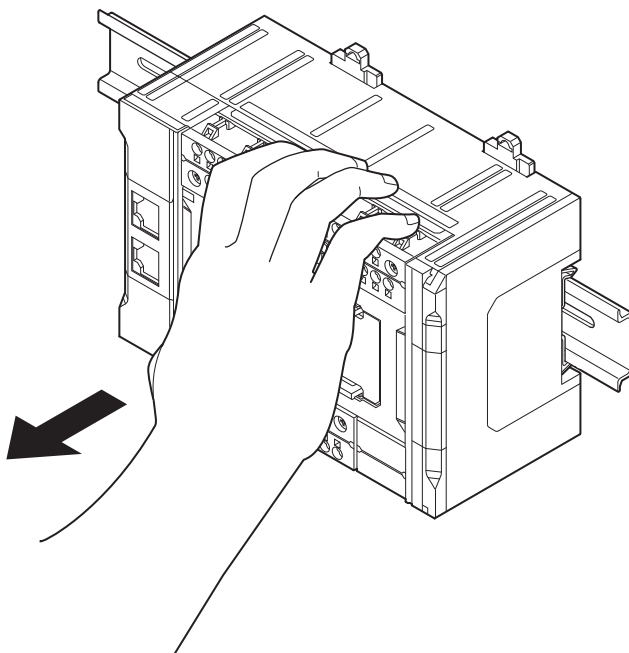

5-3-12 Removing NX Units



Precautions for Safe Use

Always turn OFF the Unit power supply and I/O power supply before you remove the NX Unit.

- 1 Use a flat-blade screwdriver to pull up the DIN Track mounting hook on the Unit to remove.

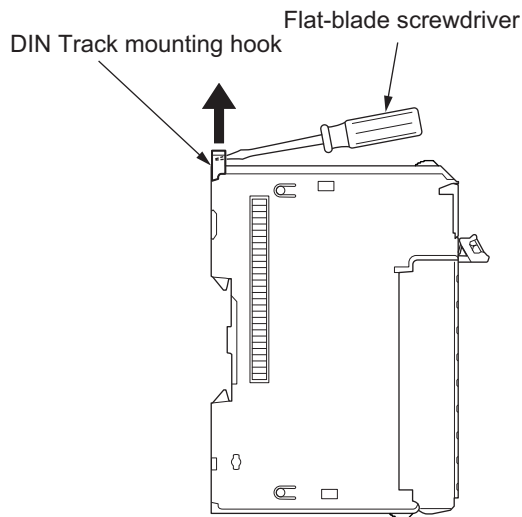

- 2 Put your fingers on the protrusions for removing multiple NX Units including the Unit to be removed, then pull out straight forward to remove.

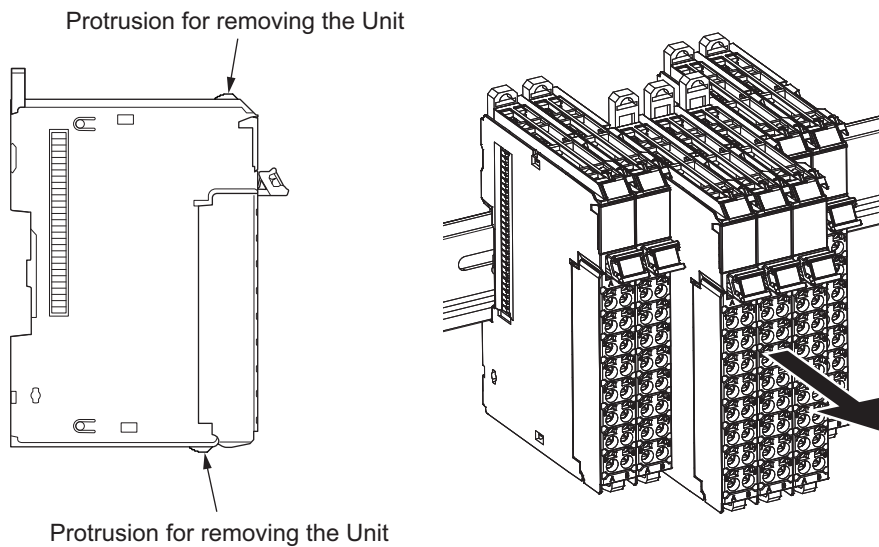

Precautions for Correct Use

- When removing an NX Unit, remove multiple Units together which include the one you want to remove. If you attempt to remove only one Unit, it is stuck and hard to pull out.
- Do not unlock the DIN Track mounting hooks on all of the NX Units at the same time. If you unlock the DIN Track mounting hooks on all of the NX Units at the same time, all of the Units may come off.
- When you remove a Unit, be careful not to touch or bump the pins in the NX bus connector.

5-3-13 Assembled Appearance and Dimensions

Installation Dimensions

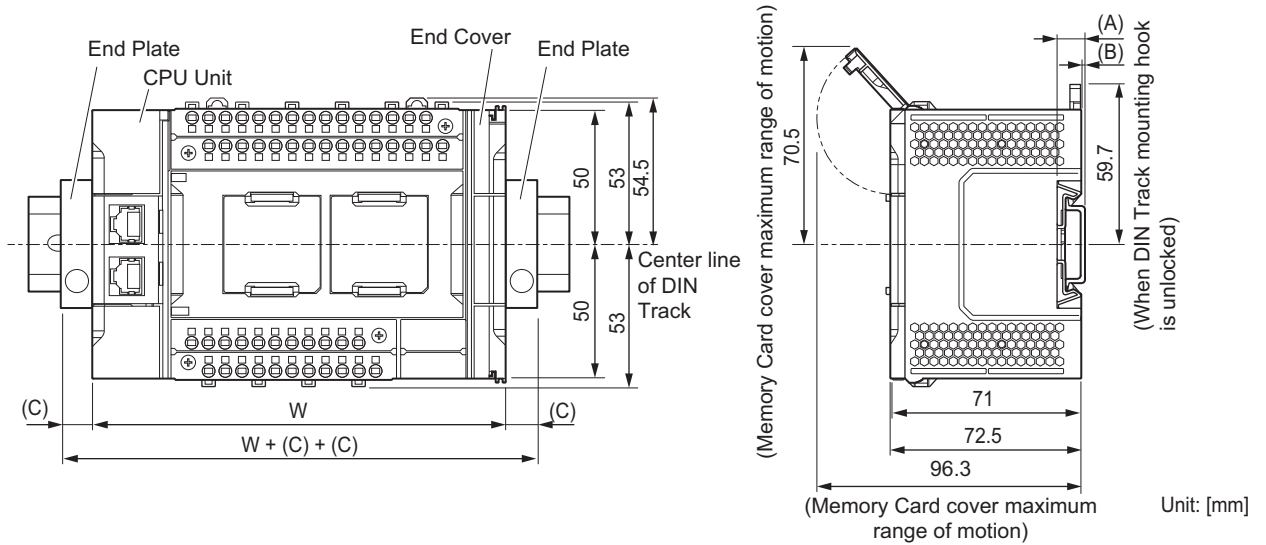

W: Width of CPU Unit (including the End Cover)

- Unit width

Model	Unit width [mm]
NX1P2-□□40DT□	154
NX1P2-9□24DT□	130

- DIN Track dimension

DIN Track model	(A) DIN Track dimension	(B) Dimension from the back of the Unit to the back of the DIN Track
PFP-100N	7.3 mm	1.5 mm
PFP-50N	7.3 mm	1.5 mm
NS 35/7,5 PERF	7.5 mm	1.7 mm
NS 35/15 PERF	15 mm	9.2 mm

- End Plate dimension

End Plate model	(C) End Plate dimension
PFP-M	10 mm
CLIPFIX 35	9.5 mm

● Depth When Option Board Is Attached

Serial Communications Option Board attached

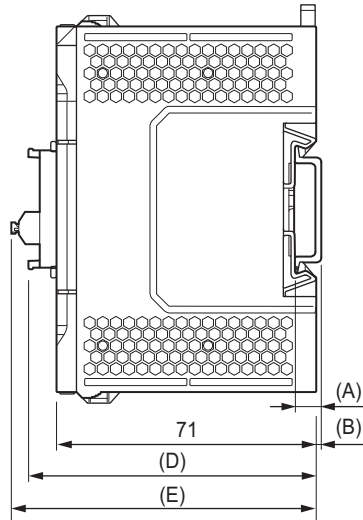

Analog I/O Option Board attached

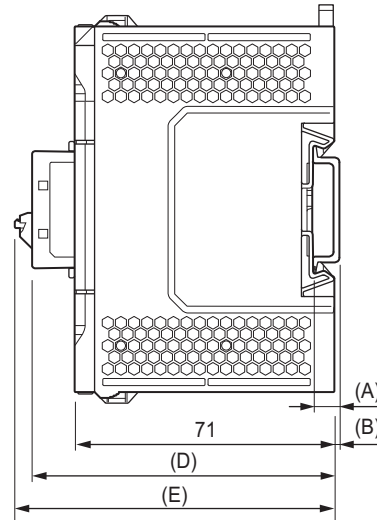

Unit: [mm]

The overall depth when an Option Board is attached is as follows.

(A) and (B) in the figure are the same as the DIN Track dimension and the dimension from the back of the Unit to the back of the DIN Track shown in the previous page, respectively.

Unit name	Model	Depth to Option Board (D)	Depth to the end of the terminal block (E)
Serial Communications Option Board	NX1W-CIF01	72.5 mm	77.8 mm
	NX1W-CIF11		74.6 mm
	NX1W-CIF12		
Analog I/O Option Board	NX1W-ADB21 NX1W-DAB21V NX1W-MAB221	83.7 mm	89.1 mm

● Calculation Example of CPU Rack Configuration Width

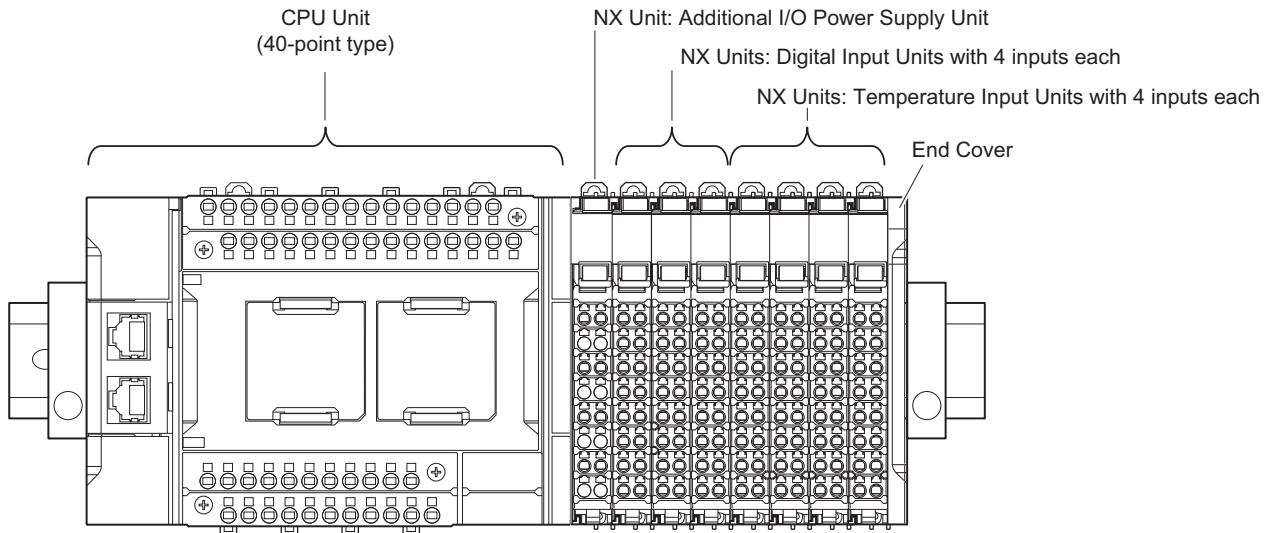

The widths of the Units in the example CPU Rack configuration and the total configuration width are given below.

Unit name	Model	Unit width	Qty	Subtotal unit width
CPU Unit	NX1P2-1140DT	154 mm	1	154 mm
Additional I/O Power Supply Unit	NX-PF0630	12 mm	1	12 mm
NX Units: Digital Input Units	NX-ID3317	12 mm	3	36 mm
NX Units: Temperature Input Units	NX-TS3101	24 mm	2	48 mm
Total (W=)				250 mm



Additional Information

You can check the width of the CPU Rack when you create the Unit configuration on the CPU and Expansion Racks Tab Page on the Sysmac Studio. On the CPU and Expansion Racks Tab Page on the Sysmac Studio, click  on the right end of the CPU Rack to display the width.

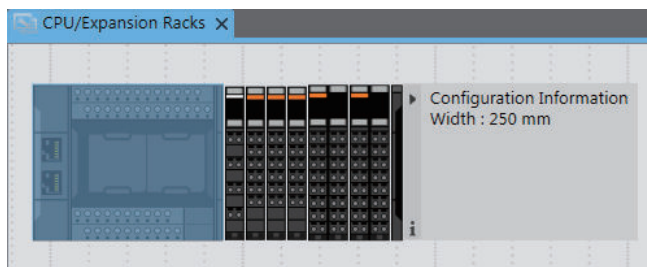

Installation Height

The installation height of the CPU Rack depends on the model of DIN Track and on the models of NX Units that are mounted.

Also, additional space is required for the cables that are connected to the Unit. Allow sufficient depth in the control panel and allow extra space when you mount the CPU Rack.

The following figure shows the dimensions from the cables connected to the CPU Rack to the back of the Unit. The unit of dimension is millimeter.

The height from the mounting surface of the DIN Track varies depending on the DIN Track to be used. Refer to *Installation Dimensions* on page 5-38 for the height of individual DIN Track type.

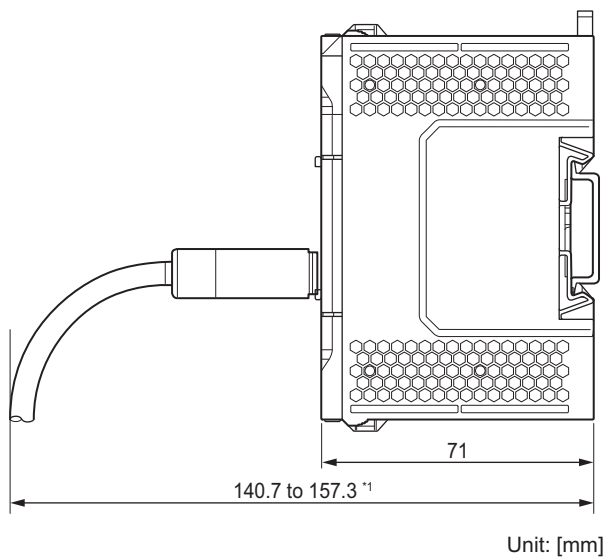

- *1. This is the dimension from the back of the Unit to the communications cables.
 Approx. 132 mm: When MPS588-C Connector is used
 Approx. 142 mm: When XS6G-T421-1 Connector is used



Precautions for Safe Use

Do not bend the cable forcibly. Doing so may break the cable.

5-4 Wiring

WARNING

- Do not input a voltage or current that exceeds the specified range into a Unit or slave. If a voltage or current that is outside the specified range is input, the Unit or slave may fail or a fire may occur.



Caution

- Tighten terminal block screws and cable screws to the torques specified in this manual or in the reference manuals. The loose screws may result in fire or malfunction.
- Do not touch devices while power is supplied or immediately after the power supply is turned OFF. You may be burnt.



Precautions for Safe Use

Use the methods that are specified in this manual for wiring the terminal blocks.



Precautions for Correct Use

Do not allow wire clippings or shavings to enter any Unit. Otherwise, Unit burning, failure, or malfunction may occur. Cover the Units or take other suitable countermeasures, especially during wiring work.

5-4-1 Wiring the Unit Power Supply

This section describes the wiring of the Unit power supply to the Unit power supply terminals on the CPU Unit.

Connect the DC power supply to the Unit power supply terminals on the left side of the input terminal block.

The + terminals and - terminals are internally connected to each other.

You can use the unwired terminals for through-wiring to an Additional NX Unit Power Supply Unit or to the Unit power supply terminals on another NX1P2 CPU Unit.

When you supply the Unit power through the unwired terminals, be careful not to exceed 4 A, the current capacity of power supply terminals.

Refer to 4-4-1 *Selecting the Unit Power Supply* on page 4-19 for information on the DC power supply to connect.

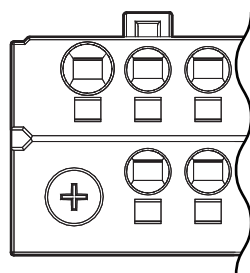

Left side of the input terminal block

This terminal arrangement is common to all models of the CPU Unit.

Refer to *Input Terminal Block* on page 3-13 under 3-1-4 *Terminal Blocks* on page 3-12 for details.

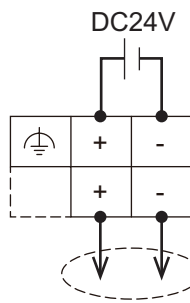

Through-wiring for unwired terminals

5-4-2 Wiring the Additional NX Unit Power Supply Unit

For information on wiring the Additional NX Unit Power Supply Unit, refer to the *NX-series System Units User's Manual* (Cat. No. W523-E1-05 or later).

5-4-3 Wiring the Additional I/O Power Supply Unit

For information on wiring the Additional I/O Power Supply Unit, refer to the *NX-series System Units User's Manual* (Cat. No. W523-E1-05 or later).

5-4-4 Wiring the Protective Devices

For information on wiring the protective devices to protect against short circuits and overcurrents of external circuits, refer to 4-4-3 *Selecting Protective Devices* on page 4-22.

5-4-5 Grounding

This section describes how to ground the CPU Rack.

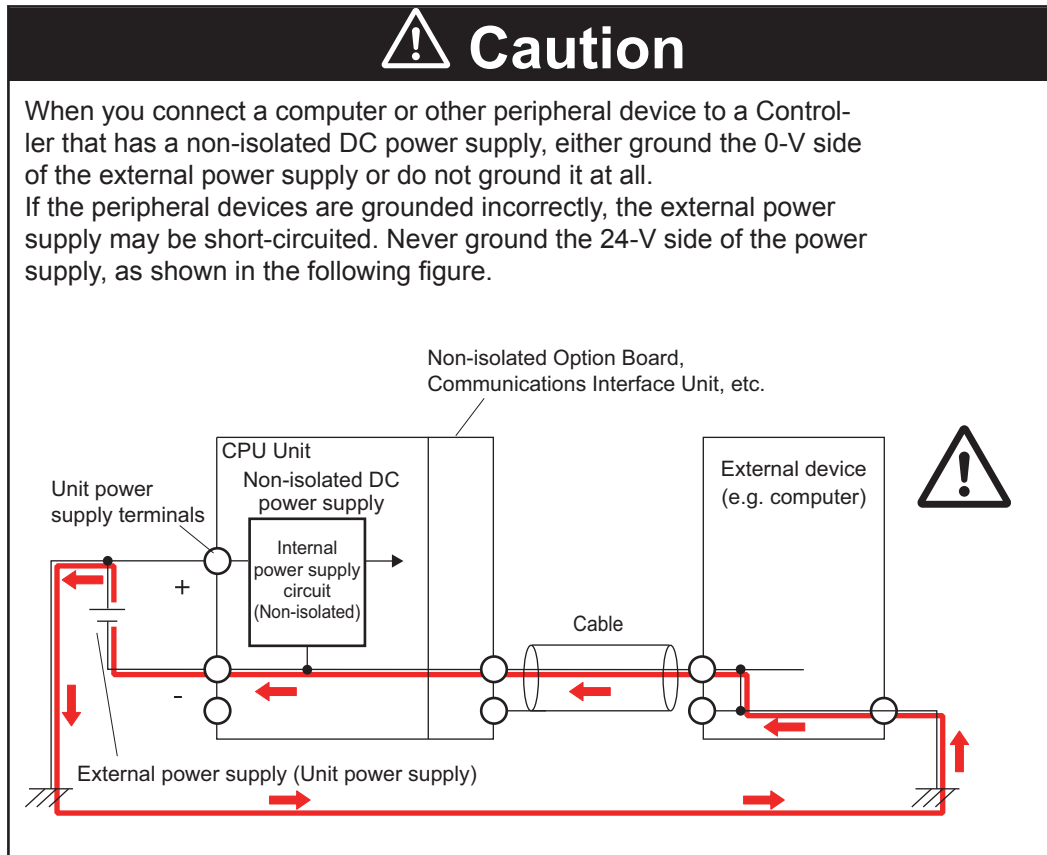

Units with Ground Terminals and Type of Ground Terminals

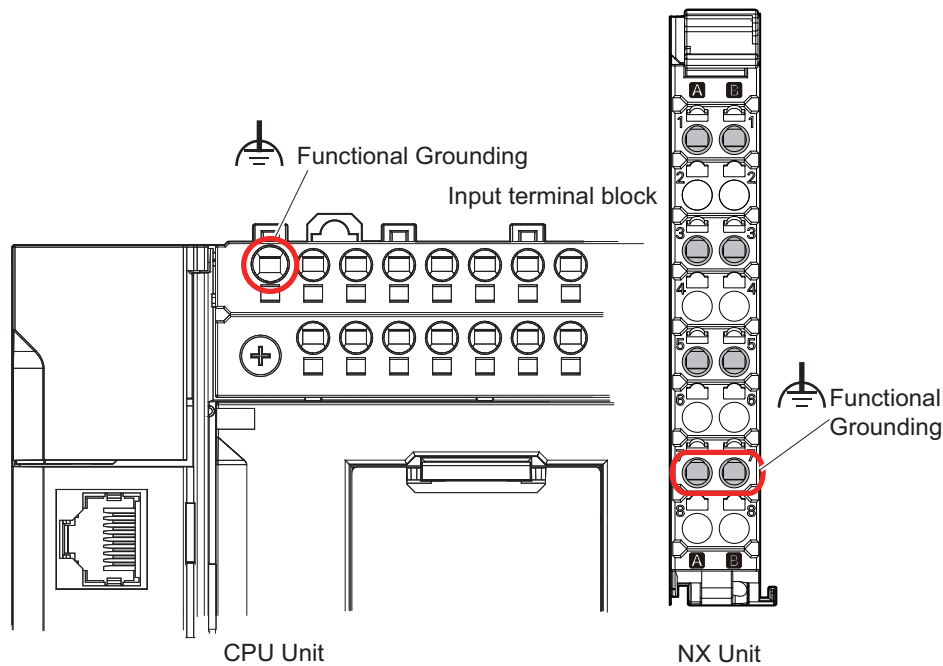

● Units with Ground Terminals

- CPU Unit
- Additional NX Unit Power Supply Unit
- Shield Connection Unit

Grounding type	Symbol	Function
Functional Grounding		Functional grounding is done to protect device and system functions, including prevention of noise from external sources, or prevention of noise from devices or equipment that could have harmful effects on other devices or equipment.

DIN Track Contact Plates

A Unit that has a ground terminal also has a DIN Track contact plate on the back of the Unit. The DIN Track contact plate is connected internally to the ground terminal on the Unit. This means that the ground terminal will be electrically connected to the DIN Track.

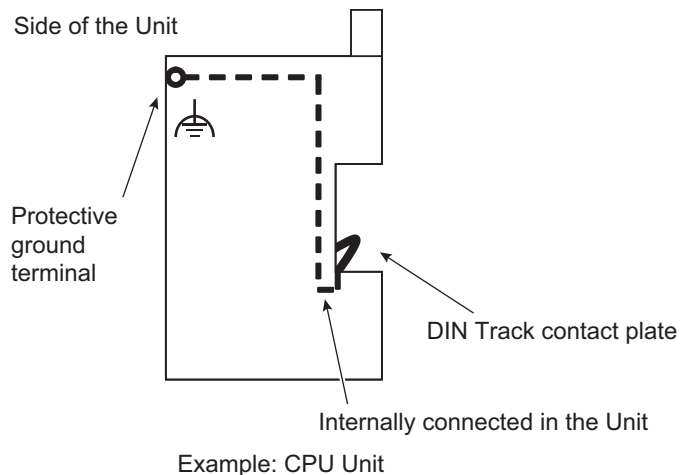

Grounding the CPU Rack

This section describes how to ground the ground terminals on the CPU Rack.

The functional ground terminals that are provided on some Units and the DIN Track are grounded.

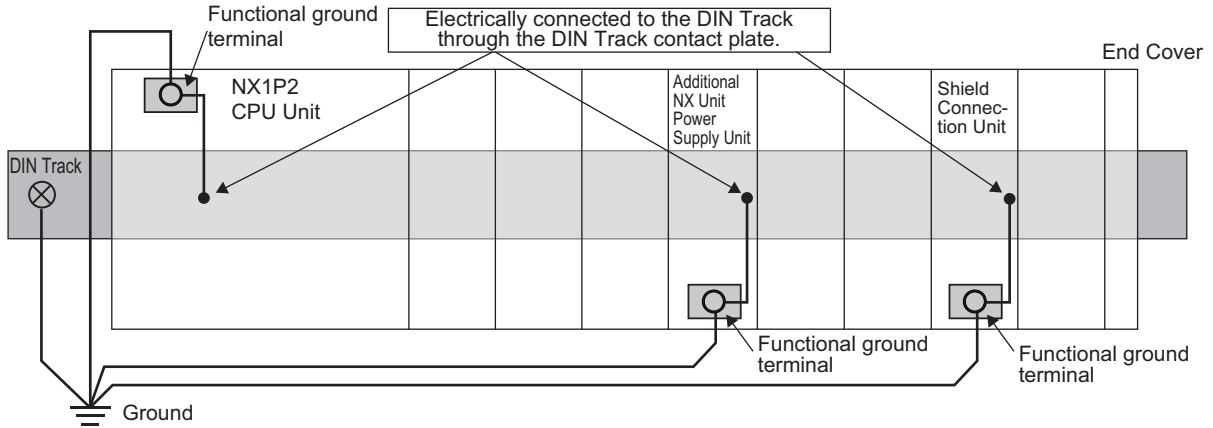

- Using a dedicated ground wire, ground the ground terminals and DIN Track with a ground resistance of 100 Ω or less.
- The ground wire should not be more than 20 m long.
- Use a ground wire that is 2.0 mm² or larger. Refer to *5-4-8 Wiring to the CPU Unit Terminal Block* on page 5-49 for information on ground wires that are applicable to the functional ground terminal on the CPU Unit. For information on ground wires that are applicable to the functional ground terminals on the Additional NX Unit Power Supply Unit or Shield Connection Unit, refer to the *NX-series System Units User's Manual* (Cat. No. W523).

If the DIN Track is made of steel and the surface is not treated to produce an insulating material, you can omit grounding the functional ground terminal on any Unit that has one, as shown in the following figures.

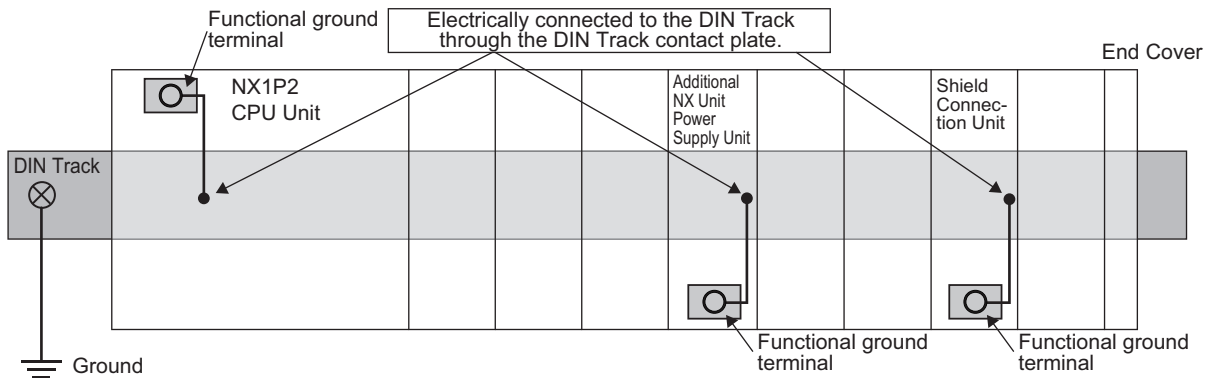

If the surface of the DIN Track is treated to produce an insulating material (e.g., anodized aluminum), the DIN Track contact plate will not be electrically connected to the DIN Track even if they are in physical contact.

Grounding the DIN Track

Attach a crimped terminal to the ground wire and then connect it to mounting hole on the DIN Track with a screw to ground the DIN Track.

Grounding the CPU Rack with Peripheral Devices and in Control Panels

Refer to *5-5-6 Grounding* on page 5-88 for the grounding procedures for the CPU Rack with peripheral devices and in control panels.

Isolating the CPU Rack from the Control Panel

If the ground wire for a Unit with a ground terminal is shared with power equipment, noise will adversely affect the Units.

You can use OMRON NX-AUX01 DIN Track Insulation Spacers with PFP-50N or PFP-100N DIN Tracks to isolate the CPU Rack from the control panel.

● Installing DIN Track Insulation Spacers and DIN Track

Secure the DIN Track Insulation Spacers to the control panel with screws, and then secure the DIN Track to the DIN Track Insulation Spacers. The recommended tightening torque for M4 screws is 1.2 N·m.

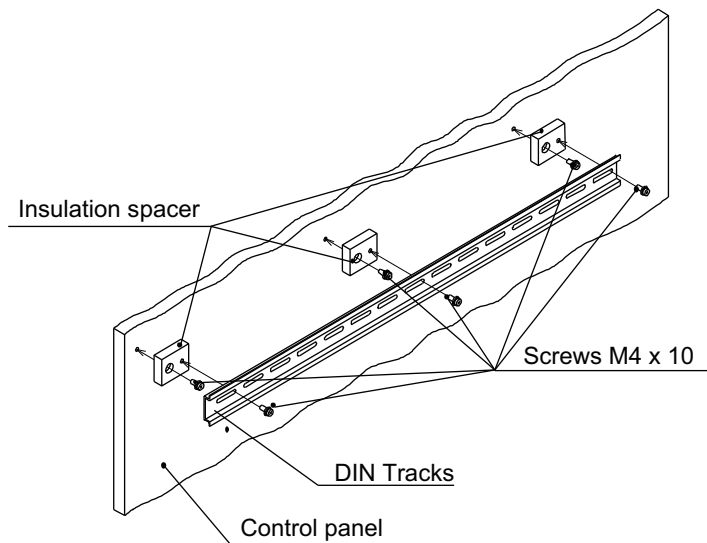

- DIN Track Insulation Spacers
NX-AUX01 (OMRON Corporation)
Three Spacers are included in one model.

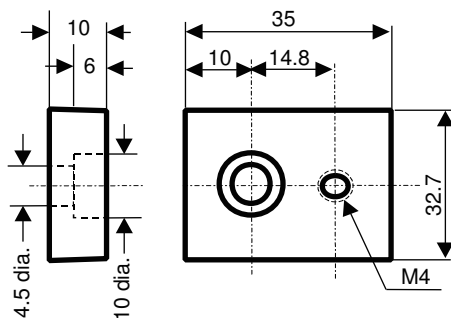

Precautions for Correct Use

If you use DIN Track Insulation Spacers to install a CPU Rack, the height will be increased by approximately 10 mm. Make sure that the CPU Rack and connecting cables do not come into contact with other devices.

5-4-6 Wiring the Built-in EtherCAT Port

For information on wiring the built-in EtherCAT port, refer to the *NJ/NX-series CPU Unit Built-in EtherCAT Port User's Manual* (Cat. No. W505).

5-4-7 Wiring the Built-in EtherNet/IP Port

For information on wiring the built-in EtherNet/IP port, refer to the *NJ/NX-series CPU Unit Built-in EtherNet/IP Port User's Manual* (Cat. No. W506).

5-4-8 Wiring to the CPU Unit Terminal Block

This section describes how to connect wires to the screwless clamping terminal block on the CPU Unit, the installation and removing methods, and functions for preventing incorrect attachment.

You can connect ferrules that are attached to the twisted wires to the screwless clamping terminal block. You can also connect the twisted wires or the solid wires to the screwless clamping terminal block. If you connect the ferrules, all you need to do to connect the wires is to insert the ferrules into the terminal holes.

WARNING

Make sure that the voltages and currents that are input to the Units and slaves are within the specified ranges. Inputting voltages or currents that are outside of the specified ranges may cause failure or fire.



Precautions for Safe Use

Use the correct wiring parts and tools when you wire the system. Otherwise, cables may be disconnected to cause short-circuit or wire breakage.

Applicable Wires

The wires that you can connect to the screwless clamping terminal block are twisted wires, solid wires, and ferrules that are attached to the twisted wires. The following section describes the dimensions and processed methods for applicable wires.

● Dimensions of Wires Connected to the Terminal Block

The dimensions of wires that you can connect into the terminal holes of the screwless clamping terminal block are as in the figure below.

Process the applicable wires that are specified in the following description to apply the dimensions.

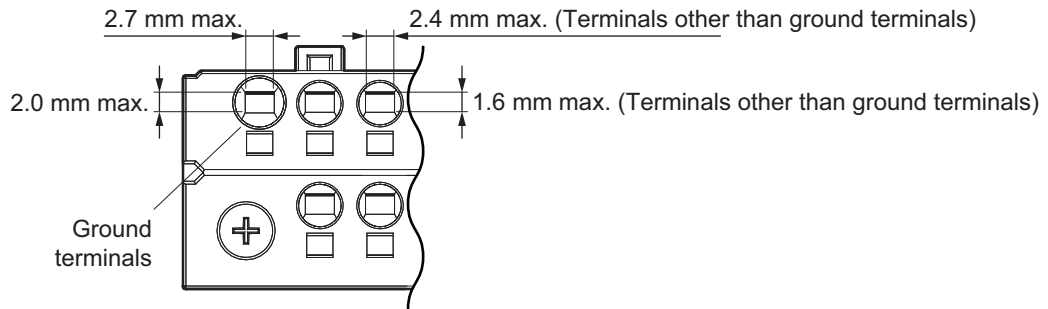

● Using Ferrules

If you use ferrules, attach the twisted wires to them.

Observe the application instructions for your ferrules for the wire stripping length when attaching ferrules.

Always use plated one-pin ferrules. Do not use unplated ferrules or two-pin ferrules.

The applicable ferrules, wires, and crimping tools are listed in the following table.

Terminal types	Manufacturer	Ferrule model *1	Applicable wire (mm ² (AWG))	Crimping tool (applicable wire size given in parentheses)
All terminals except ground terminals	Phoenix Contact	AI0,25-8	0.25 (#24)	Phoenix Contact CRIMPFOX 6 (0.25 to 6 mm ² , AWG24 to 10)
		AI0,5-8	0.5 (#20)	
		AI0,5-10		
		AI0,75-8	0.75 (#18)	
		AI0,75-10		
		AI1,0-8	1.0 (#18)	
		AI1,0-10		
		AI1,5-8	1.5 (#16)	
Ground terminals		AI2,5-8	2.5 (#14)	
		AI2,5-10		
All terminals except ground terminals	Weidmuller	H0.14/12	0.14 (#26)	Weidmuller PZ 6 Roto (0.14 to 6 mm ² , AWG26 to 10)
		H0.25/12	0.25 (#24)	
		H0.34/12	0.34 (#22)	
		H0.5/14	0.5 (#20)	
		H0.5/16		
		H0.75/14	0.75 (#18)	
		H0.75/16		
		H1.0/14	1.0 (#18)	
		H1.0/16		
		H1.5/14	1.5 (#16)	
Ground terminals		H2.5/15D	2.5 (#14)	
		H2.5/16DS		
All terminals except ground terminals	Wago	FE-0.25-8N	0.25 (#24)	Wago Variocrimp 4 (0.25 to 4 mm ² , AWG24 to 12)
		FE-0.34-8N	0.34 (#22)	
		FE-0.5-8N	0.5 (#20)	
		FE-0.5-10N		
		FE-0.75-8N	0.75 (#18)	
		FE-0.75-10N		
		FE-1.0-8N	1.0 (#18)	
		FE-1.0-10N		
Ground terminals		FE-1.5-8N	1.5 (#16)	
		FE-1.5-10N		
Ground terminals		FE-2.5-8N	2.5 (#14)	
		FE-2.5-10N		

*1. This represents a typical model. Actually, colored codes and other information is added.

When you use any ferrules other than those in the above table, crimp them to the twisted wires so that the following processed dimensions are achieved.

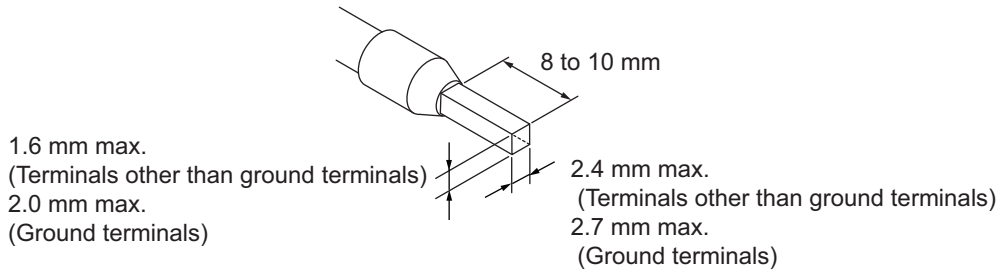

● **Using Twisted or Solid Wires**

If you use twisted wires or solid wires, use the following table to determine the correct wire specifications.

Terminals		Wire type				Wire size	Conductor length (stripping length)
		Twisted wires		Solid wire			
Classification	Current capacity	Plated	Unplated	Plated	Unplated		
All terminals except ground terminals	2 A max.	Possible	Possible	Possible	Possible	0.08 to 1.5 mm ² (AWG 28 to 16)	8 to 10 mm
	Greater than 2 A and 4 A or less		Not possible	Possible ^{*1}	Not possible		
Ground terminals	---	Possible	Possible	Possible	Possible	2.0 mm ²	10 to 12 mm

*1. Secure wires to the screwless clamping terminal block. Refer to *Securing Wires* on page 5-55 for how to secure wires.



Precautions for Correct Use

- Use cables with suitable wire sizes for the carrying current. There are also restrictions on the current due to the ambient temperature. Refer to the manuals for the cables and use the cables correctly for the operating environment.
- For twisted wires, strip the sheath and twist the conductor portion. Do not unravel or bend the conductor portion of twisted wires or solid wires.

NG

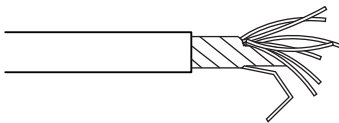

Unravel wires

NG

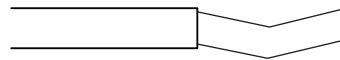

Bend wires



Additional Information

If more than 2 A will flow on the wires, use plated wires or use ferrules.

Connecting/Removing Wires

This section describes how to connect and remove wires.

● Terminal Block Parts and Names

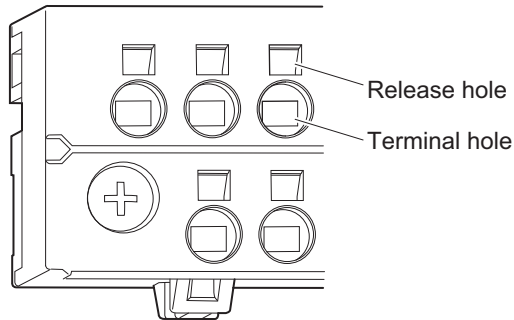

The above figure shows the output terminal block at the bottom. For the input terminal block, turn it upside down.

● Required Tools

Use a flat-blade screwdriver to connect and remove wires.

Use the following flat-blade screwdriver.

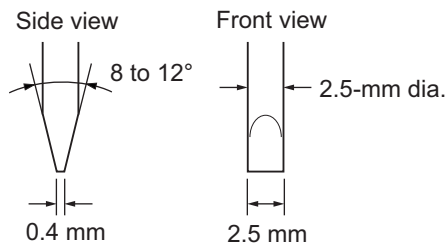

Recommended screwdriver model

Model	Manufacturer
SZS 0,4×2,5	Phoenix Contact
SZF 0-0,4×2,5* ¹	
ESD 0.40×2.5	Wera
0,4×2,5×75 302	Wiha
AEF.2,5×75	Facom
210-719	Wago
SDI 0.4×2.5×75	Weidmuller

*1. You can purchase the SZF 0-0,4×2,5 screwdriver (manufactured by Phoenix Contact) from OMRON by specifying the OMRON's model number (XW4Z-00B).

● Connecting Ferrules

Insert the ferrule straight into the terminal hole.

It is not necessary to press a flat-blade screwdriver into the release hole.

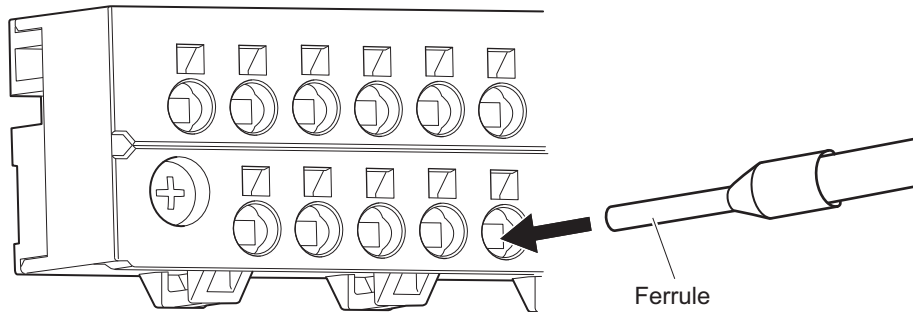

After you make a connection, make sure that the ferrule is securely connected to the terminal block.

● Connecting Twisted Wires/Solid Wires

Use the following procedure to connect the twisted wires or solid wires to the terminal block.

- 1 Press the a flat-blade screwdriver straight into the release hole.
If you press in the screwdriver correctly, you will feel the spring in the release hole, and the screw driver will begin to incline.

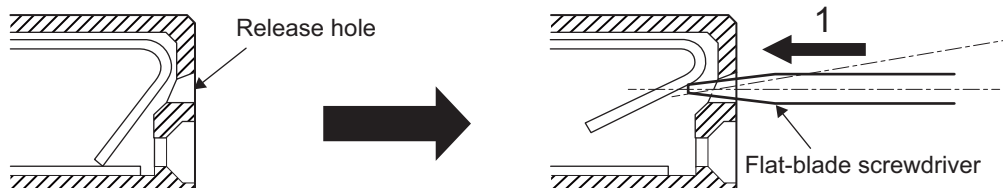

- 2 Leave the flat-blade screwdriver pressed into the release hole and insert the twisted wire or the solid wire into the terminal hole.
Insert the twisted wire or the solid wire until the stripped portion is no longer visible to prevent shorting.

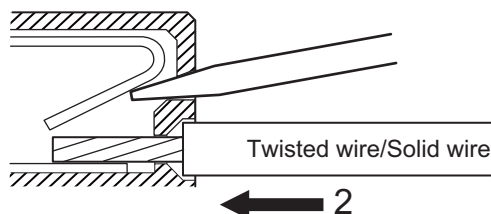

- 3 Remove the flat-blade screwdriver from the release hole.

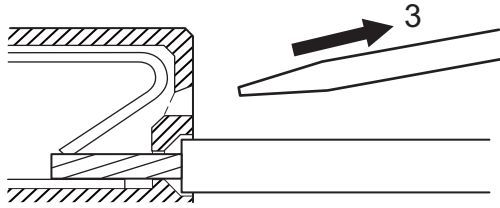

After you make a connection, lightly pull the twisted wire or the solid wire to make sure that the wire is securely connected to the terminal block.



Precautions for Safe Use

- When you insert a flat-blade screwdriver into a release hole, press it down with a force of 30 N max. Applying excessive force may damage the terminal block.
- Do not tilt or twist the flat-blade screwdriver while it is pressed into the release hole. Doing so may break the terminal block.

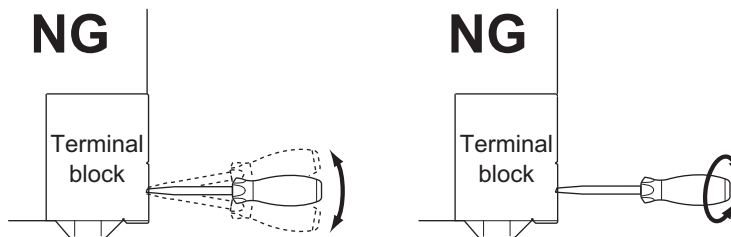

- Make sure that all wiring is correct.
- Do not bend the cable forcibly. Doing so may sever the cable.
- The angle at which you insert a screwdriver in the release holes on the screwless clamping terminal blocks of the CPU Unit is different from that on the screwless clamping terminal blocks of NX Units. Check the wiring method for the NX Unit and perform wiring correctly. Refer to the user's manual of the specific NX Unit for how to wire an NX Unit.

● Securing Wires

It is necessary to secure wires to the screwless clamping terminal block depending on the wire types that are used or the current flows on the wires.

The following table gives the necessity for securing wires.

Terminals		Wire type				
		Ferrule	Twisted wires		Solid wire	
Classifica-tion	Current capacity		Plated	Unplated	Plated	Unplated
All terminals except ground terminals	2 A max.	No	No	No	No	No
	Greater than 2 A and 4 A or less			Not possible	Yes	Not possible
Ground terminals	---		No	No	No	No

Use the following procedure to secure the wires.

- 1 Prepare a cable tie.
A cable tie can be used with a width of 4 mm or less and a thickness of 1.5 mm or less.
Select a cable tie correctly for the operating environment.

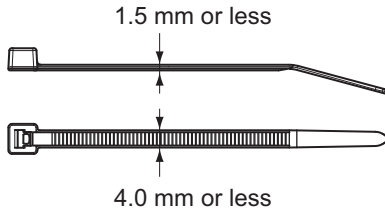

- 2** Pass a cable tie through the holes for securing wires on the upper and lower sides of the screwless clamping terminal block.

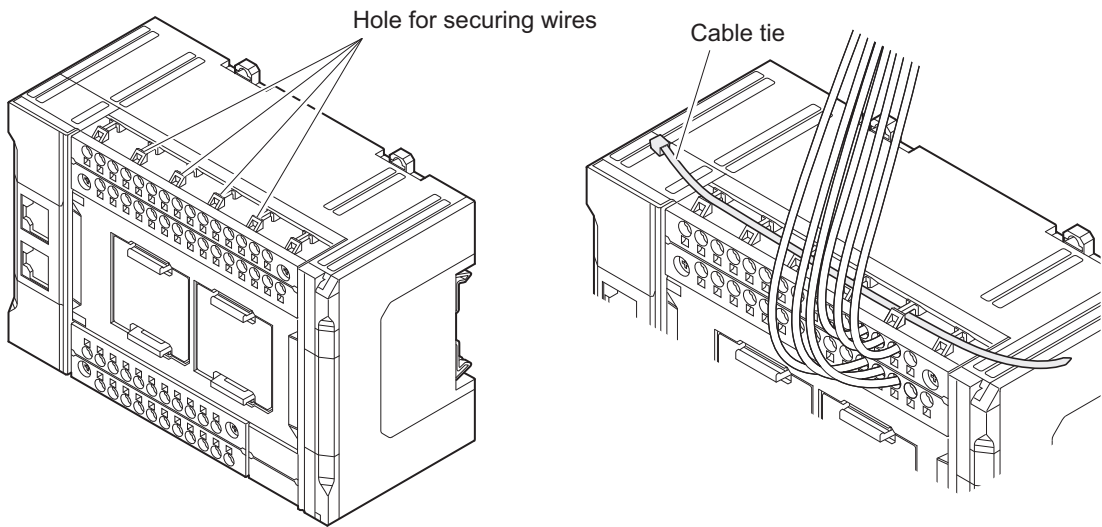

- 3** Bundle five to six wires with a cable tie and secure them to the screwless clamping terminal block.

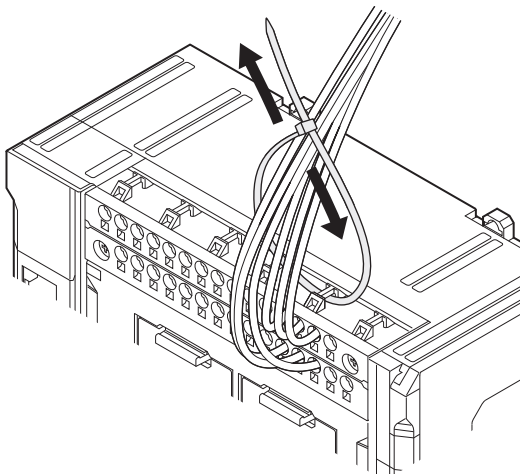

Secure wires within the range of 30 mm from the screwless clamping terminal block. Also, leave spaces above and below the CPU Rack to ensure ventilation, as shown in the following figure.

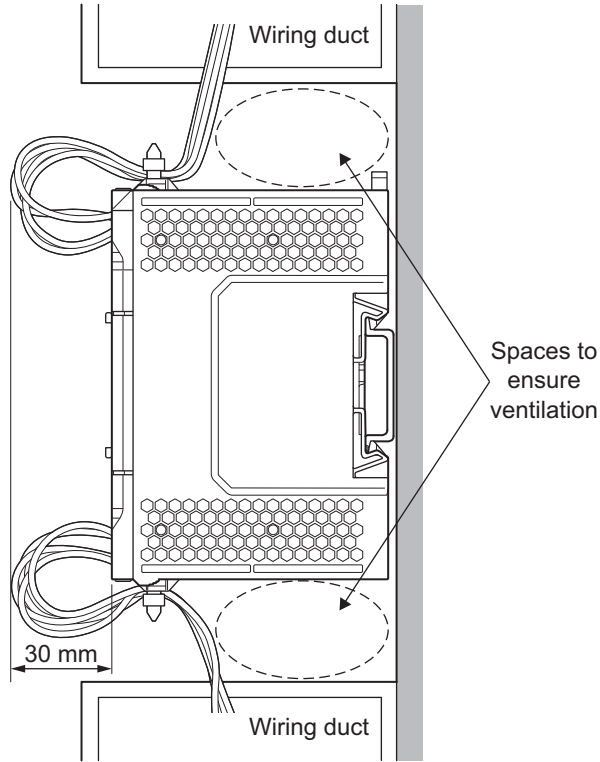

● Removing Wires

Use the following procedure to remove the wires from the terminal block. The removal method is the same for ferrules, twisted wires, and solid wires.

If wires are secured firmly to the terminal block, release them first.

- 1** Press the a flat-blade screwdriver straight into the release hole. If you press in the screwdriver correctly, you will feel the spring in the release hole, and the screw driver will begin to incline.

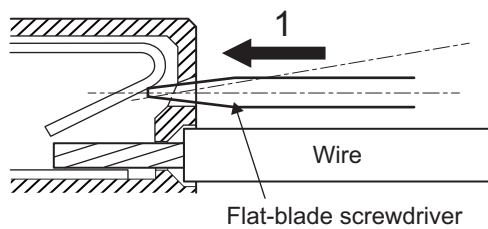

- 2** Leave the flat-blade screwdriver pressed into the release hole and pull out the wire.

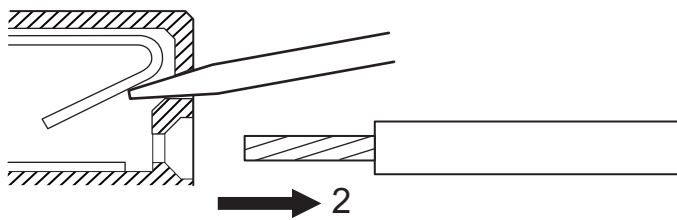

- 3** Remove the flat-blade screwdriver from the release hole.

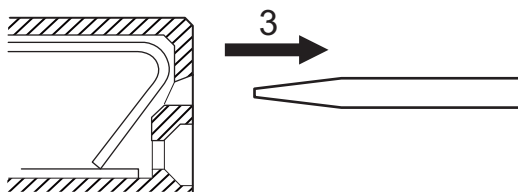



Precautions for Safe Use

- When you insert a flat-blade screwdriver into a release hole, press it down with a force of 30 N max. Applying excessive force may damage the terminal block.
- Do not tilt or twist the flat-blade screwdriver while it is pressed into the release hole. Doing so may break the terminal block.

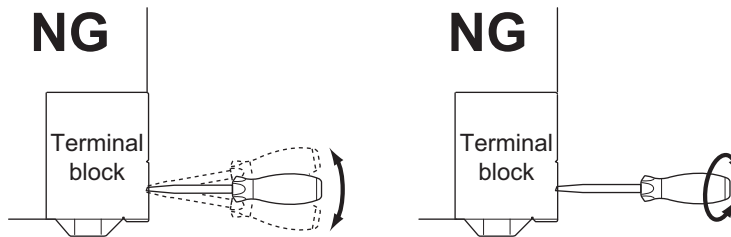

- Make sure that all wiring is correct.
- Do not bend the cable forcibly. Doing so may sever the cable.
- The angle at which you insert a screwdriver in the release holes on the screwless clamping terminal blocks of the CPU Unit is different from that on the screwless clamping terminal blocks of NX Units. Check the wiring method for the NX Unit and perform wiring correctly. Refer to the user's manual of the specific NX Unit for how to wire an NX Unit.

Removing a Terminal Block

- 1 Loosen the M3 screws on the right and left sides of the terminal block, and remove the terminal block.
These screws are the self-raising screws, so the terminal block is raised when they are loosened. Loosen the right and left screws alternately if they are hard to loosen.

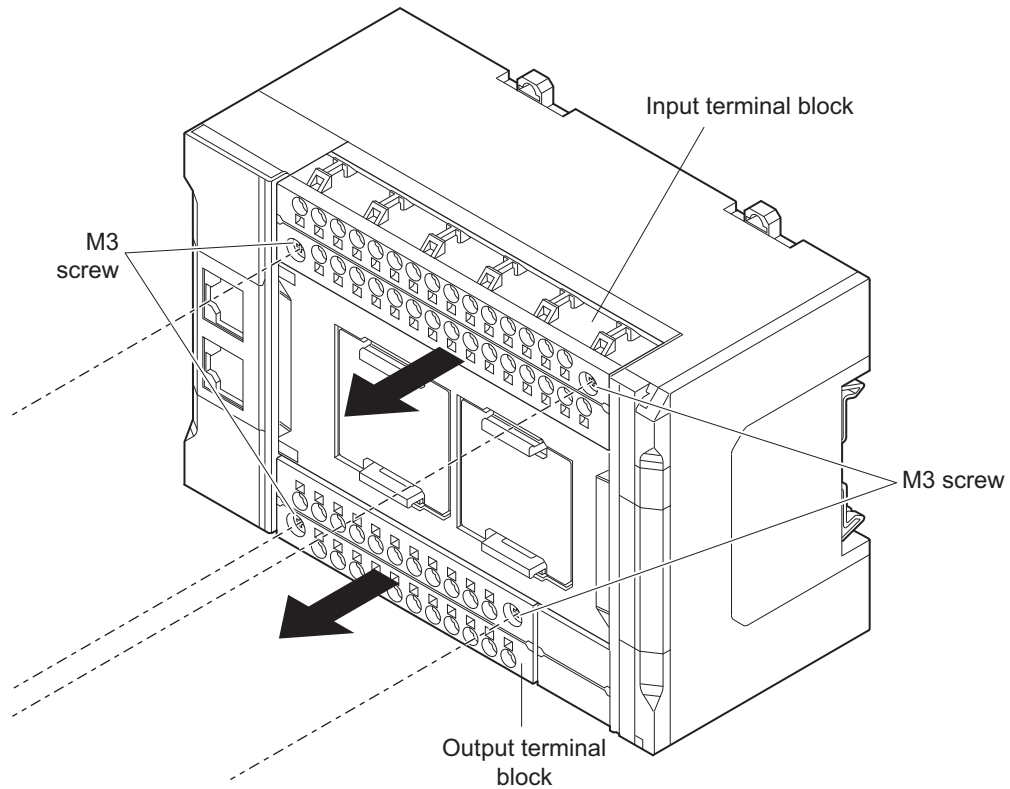

Attaching a Terminal Block

Caution

Be sure that all terminal fixing screws are tightened to the specified torque. Loose screws may result in fire or malfunction.



- 1 Press the terminal block into the CPU Unit, and tighten the M3 screws on the right and left sides of the terminal block to mount it securely. These screws are the self-raising screws, so you need to tighten the screws to connect the terminal block. Tighten the right and left screws alternately if they are hard to tighten. If the terminal blocks are only pressed into positions, it is not fixed and electrical connection is not ensured. Be sure to tighten the right and left screws firmly. Tighten the screws to the torque of 0.5 N·m. After you mount the terminal block, make sure that it is fixed to the Unit.

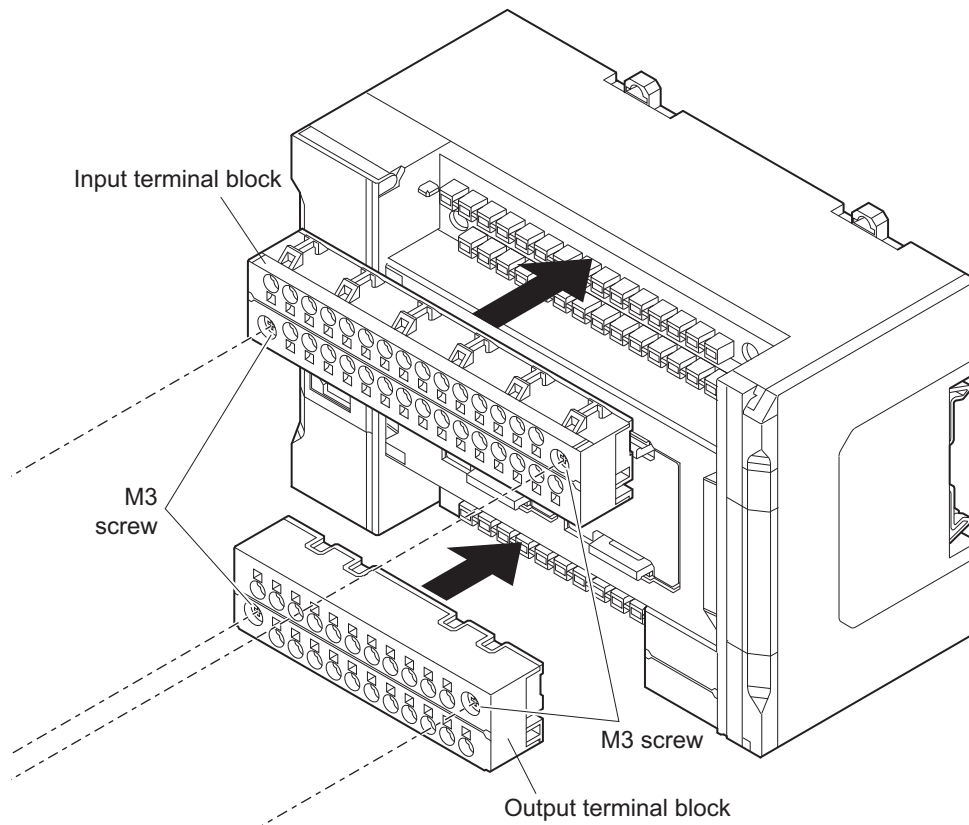

Preventing Incorrect Attachment of Terminal Blocks

This feature is intended for the NX1P2-9□24DT□ CPU Unit that has 24 built-in I/O points and prevents incorrect attachment of input and output terminal blocks.

Although the shapes of the input and output terminal blocks are the same, they cannot be swapped and attached in the wrong way. This feature prevents troubles caused by a terminal block that is attached to a wrong place after it is wired.

When you remove the terminal blocks from the CPU Unit for wiring, be careful not to swap and attach the input terminal block and output terminal block in the wrong way.

The following figure shows how to distinguish the input and output terminal blocks from each other.

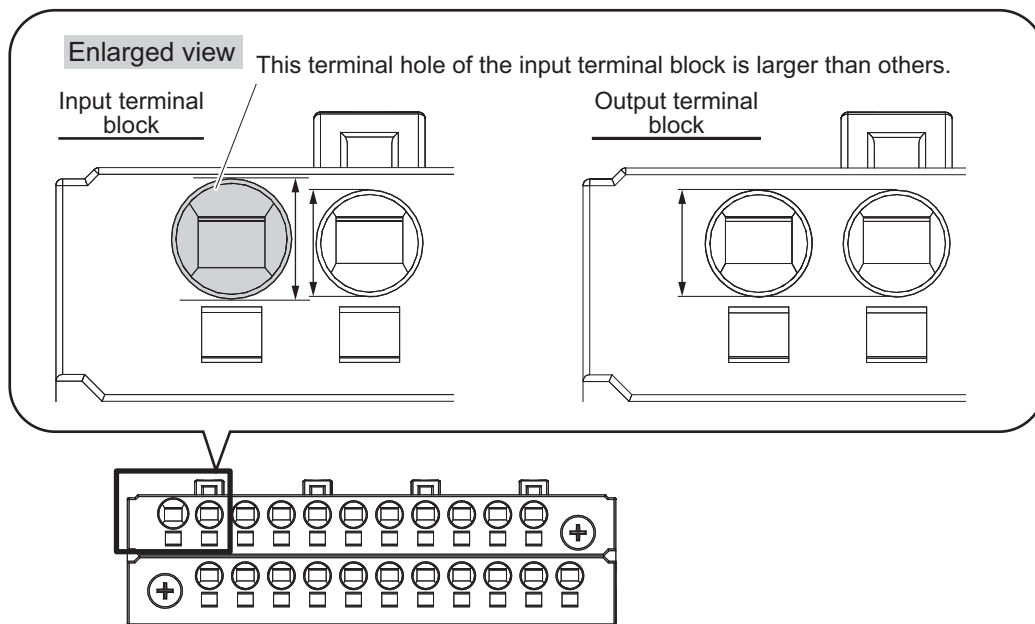

Additional Information

As shown below, incorrect attachment of the terminal blocks is prevented by the ribs. Do not attach the terminal block forcefully.

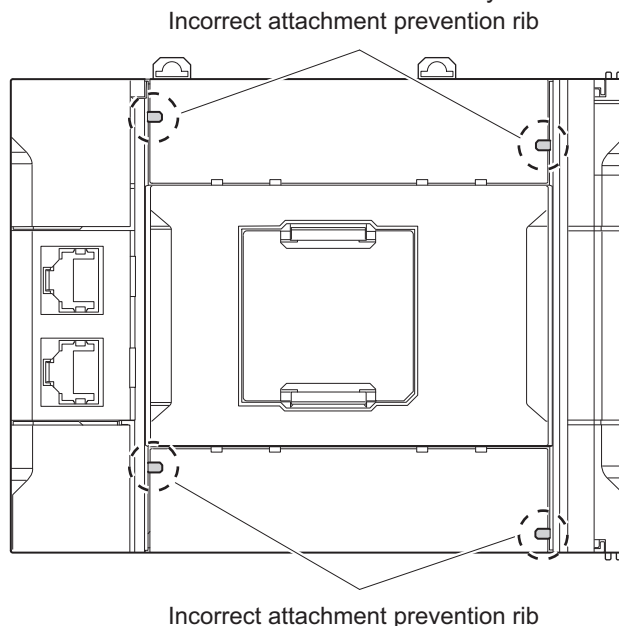

5-4-9 Wiring the built-in I/O

This section gives some wiring examples for the built-in I/O and precautions for wiring.

Wiring the Built-in Input

Use the following information for reference when selecting or connecting input devices.

● DC Input Devices Which Can Be Connected (DC Output)

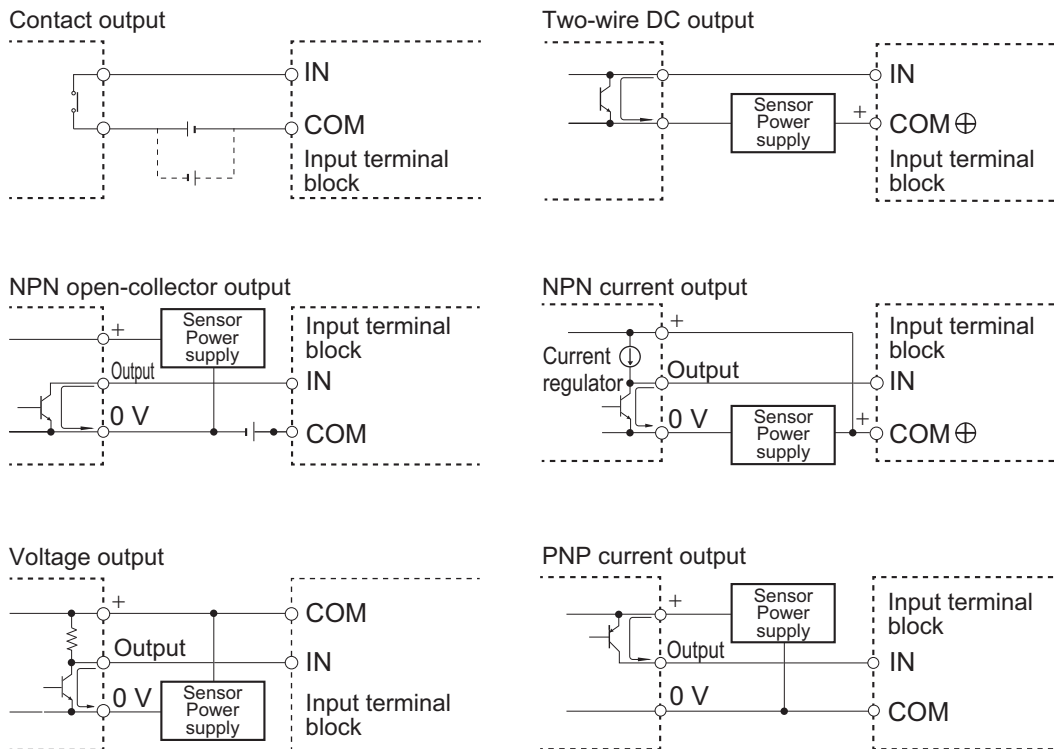

• The circuit below should not be used for I/O devices having a voltage output.

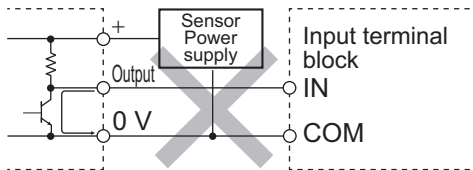

● Precautions When Connecting a Two-wire DC Sensor

When a two-wire sensor is used with a DC input, check that the following conditions are met. Failure to meet these conditions may result in operating errors.

(a) Relation between ON voltage of the DC input and sensor residual voltage

$$V_{ON} \leq V_{CC} - V_R$$

(b) Relation between input current to the DC input and sensor control output (load current)

$$I_{OUT}(\min) \leq I_{ON} \leq I_{OUT}(\max)$$

$$I_{ON} = (V_{CC} - V_R - 1.5 \text{ [internal residual voltage of DC input]}) / R_{IN}$$

When I_{ON} is smaller than $I_{OUT} \text{ (min)}$, connect a bleeder resistor R. The bleeder resistor constant can be calculated as follows:

$$R \leq (V_{CC} - V_R) / (I_{OUT} \text{ (min)} - I_{ON})$$

$$\text{Power } W \text{ of bleeder resistor} \geq (V_{CC} - V_R)^2 / R \times 4 \text{ [allowable margin]}$$

V_{CC} : Input voltage of DC input

V_R : Sensor's output residual voltage

I_{ON} : Input current of DC input

I_{OUT} : Sensor control current (load current)

R_{IN} : Input resistor of DC input

(c) Relation between OFF current of the DC input and sensor leakage current

$$I_{OFF} \geq I_{leak}$$

When I_{leak} is greater than I_{OFF} , connect a bleeder resistor R.

Use the following equation to calculate the bleeder resistance constant.

$$R \leq R_{IN} \times V_{OFF} / (I_{leak} \times R_{IN} - V_{OFF})$$

$$\text{Power } W \text{ of bleeder resistor} \geq (V_{CC} - V_R)^2 / R \times 4 \text{ [allowable margin]}$$

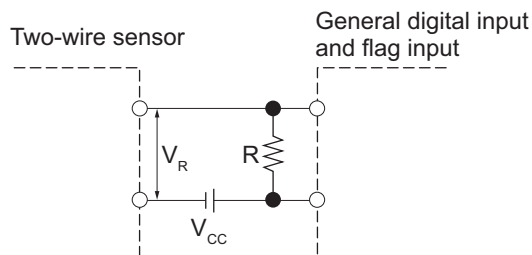

V_{CC} : Power supply voltage

V_{ON} : ON voltage of DC input

V_{OFF} : OFF voltage of DC input

I_{ON} : ON current of DC input

I_{OFF} : OFF current of DC input

R_{IN} : Input resistor of DC input

V_R : Sensor's output residual voltage

I_{OUT} : Sensor control output (load current)

I_{leak} : Sensor leakage current

R: Bleeder resistor

(d) Precautions on sensor inrush current

An incorrect input may occur due to sensor inrush current if a sensor is turned ON after the DC input section has started up to the point where inputs are possible.

Determine the time required for sensor operation to stabilize after the sensor is turned ON and take appropriate measures, such as inserting an ON delay into the user program after turning ON the sensor.

A programming example is shown below.

The sensor's power supply voltage is used as the input bit to *Sensor_power*.

A 100-ms timer delay (the time required for an OMRON Proximity Sensor to stabilize) is created in the user program.

After the timer changes to TRUE, input bit *X* causes *Output* to change to TRUE after the input of the sensor changes to TRUE.

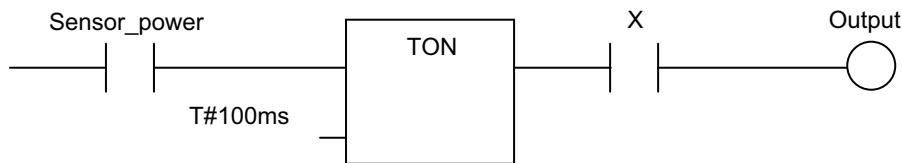

Output Short-circuit Protection Function of the Built-in Output

If a load connected to the output terminals is short-circuited, output components and printed circuit boards may be damaged. To guard against this, the PNP output type includes the short-circuit protection function.

When using the PNP output that does not include the short-circuit protection, incorporate a protective fuse in the output circuit. Use a fuse with a capacity of around twice the rated output.

Consideration for Inrush Current from Built-in Output

When connecting a transistor to an output device with a high inrush current (such as an incandescent lamp), steps must be taken to avoid damage to the output transistor.

Use either of the following methods to reduce the inrush current.

● Countermeasure 1

Draw about 1/3 of the current consumed by the load.

NPN (sinking) type

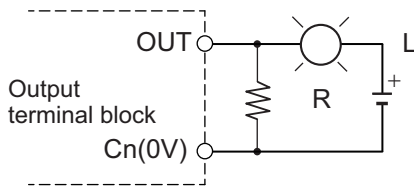

PNP (sourcing) type

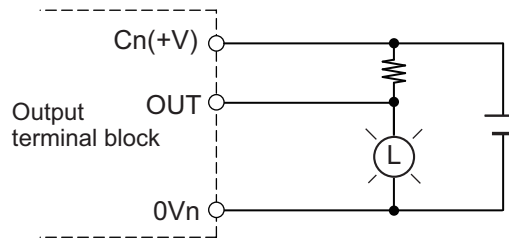

● Countermeasure 2

Mount a limiting resistor.

NPN (sinking) type

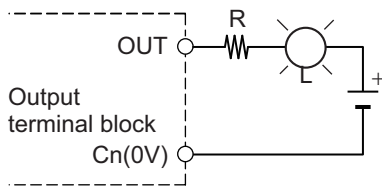

PNP (sourcing) type

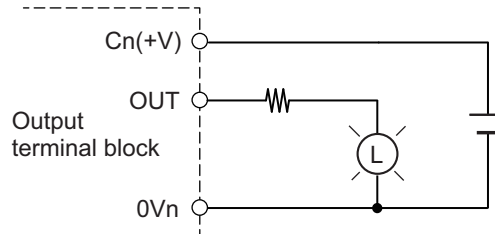

In countermeasure 1, the current consumption from I/O power supply is increased although the voltage supplied to the load L is not decreased.

In countermeasure 2, the voltage supplied to the load L is decreased although the current consumption from I/O power supply is not increased.

Select the appropriate countermeasures according to the operating conditions.

Cn(0V) and Cn(+V) in the figure represent the common terminals, and 0Vn represents the terminal of the power supply to drive the output circuit. Refer to *Output Terminal Block* on page 3-15 under 3-1-4 *Terminal Blocks* on page 3-12 for details.

5-4-10 Wiring the NX1W-CIF01 Serial Communications Option Board

This section explains the wiring of an NX1W-CIF01 Serial Communications Option Board.

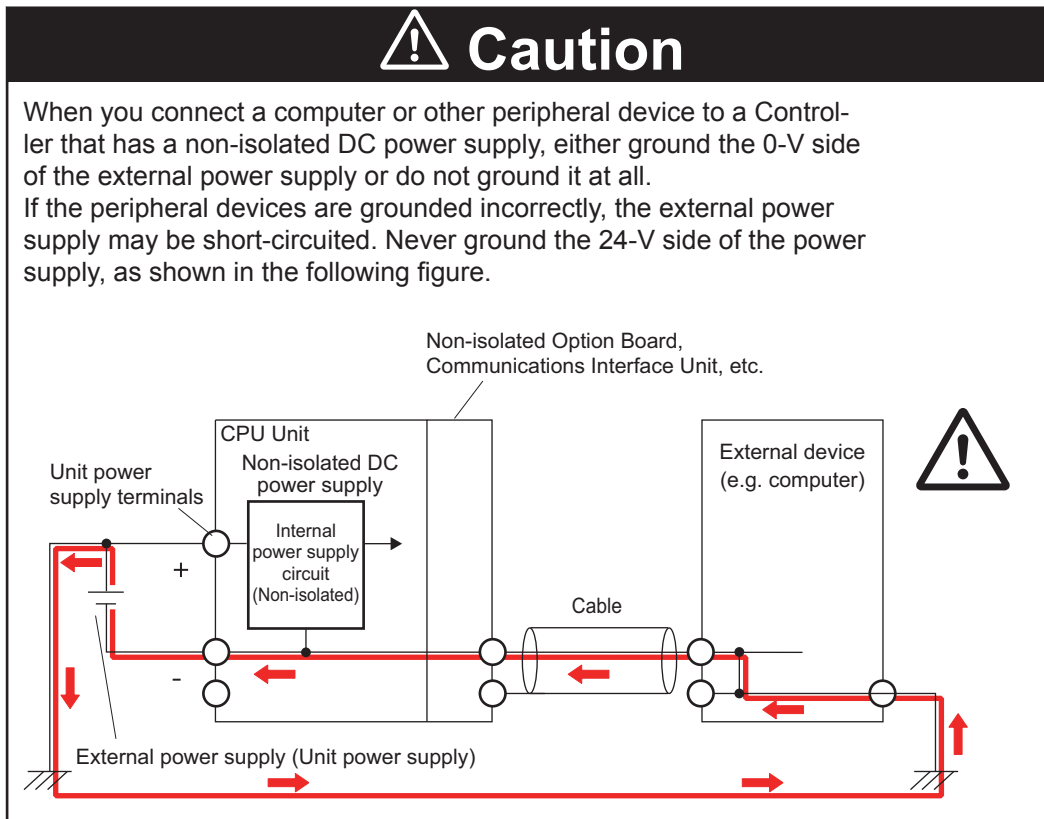

Recommended RS-232C Wiring

We recommend the following wiring method for the RS-232C, especially in environments prone to noise.

- 1** Use shielded twisted-pair cables for the communications cables.
 - Recommended RS-232C Cables

Model numbers	Manufacturer
UL2464 AWG28x5P IFS-RVV-SB (UL product) AWG28x5P IFVV-SB (non-UL product)	Fujikura Ltd.
UL2464-SB (MA) 5P×28AWG (7/0.127) (UL product) CO-MA-VV-SB 5P×28AWG (7/0.127) (non-UL product)	Hitachi Cable, Ltd.

- 2** Combine a signal wire and SG (signal ground) wire in a twisted-pair cable. At the same time, bundle the SG wires at the connectors on Option Board and the remote device.
- 3** Connect the SHLD of the communications cable to the SHLD on the Option Board.

● **Connection Example**

Example: Twisted-pair cable connecting SD-SG, and RD-SG terminals when serial communications mode is the host link.

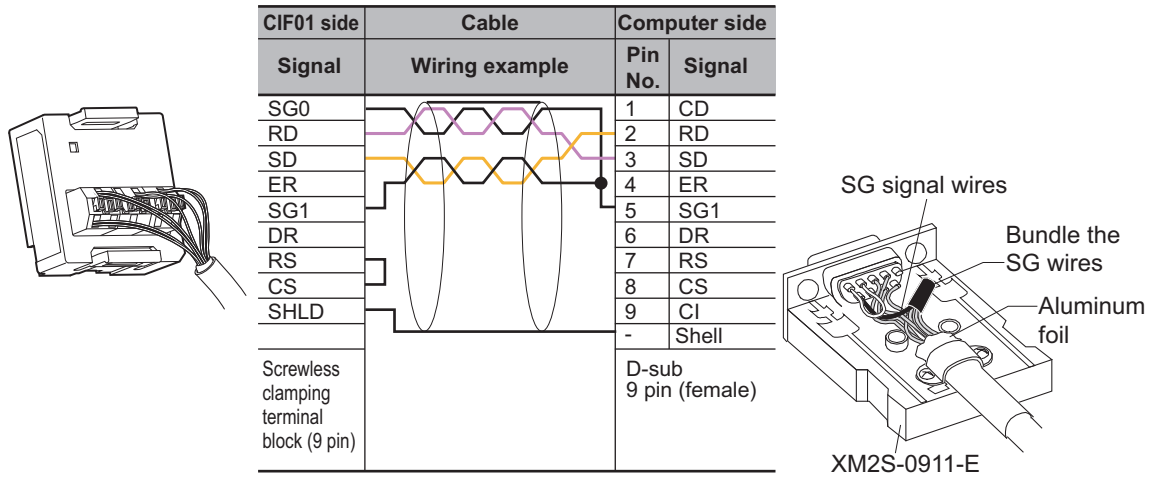

Example: When using cables and devices that you used with CS/CJ/CP Series.

Prepare a cable to convert the terminal block on the Serial Communications Option Board into the D-sub9 for CS/CJ/CP Series.

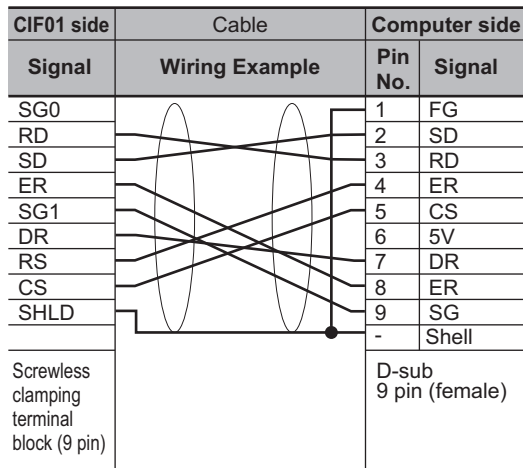

Wiring to Terminal Block of the NX1W-CIF01

- 1 Cut the cable to the required length.
- 2 Remove the specified length of the sheath.
Be careful not to scratch the braided shield.

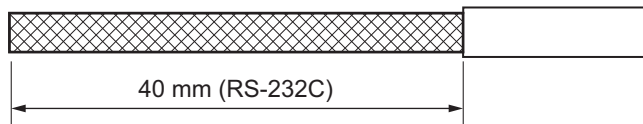

- 3 Unbraid and put up the braided shield.

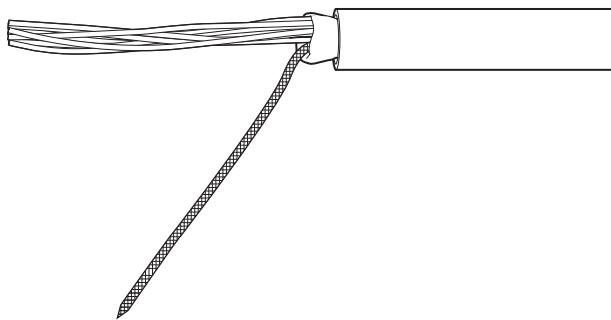

- 4 Remove the insulation from each core wire using a stripper. Cover the braided shield with a heat-shrinking tube (3.0 dia.), and heat the tube to shrink it in place.

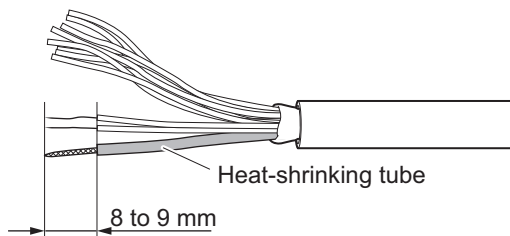

- 5 Using a thin flat-blade screwdriver, press in the release button of the terminal block. Insert the cable core wire into the terminal hole. Confirm that the core wire exposed part is fully inserted into the terminal hole, and then release the release button.

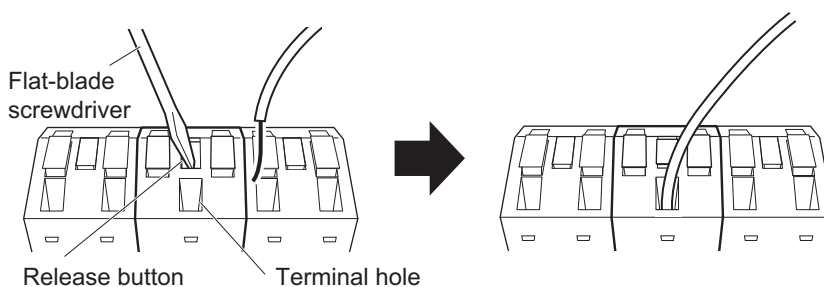

To remove the wire, press in the release button with a thin flat-blade screwdriver, and pull out the wire while it is unlocked.

A thin flat-blade screwdriver such as the one shown below is required to connect or remove cables.

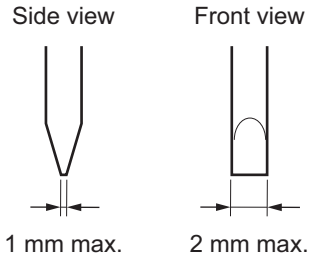

Wiring to the D-sub Connector

This section explains how a communications cable which is connected to the NX1W-CIF01 is connected to an external device through wiring to a D-sub connector.

Use the following steps to wire connectors.

See the following diagrams for the length of the cable portion to be cut in each step.

- 1** Cut the cable to the required length.
- 2** Remove the specified length of the sheath.
Be careful not to scratch the braided shield.



- 3** Trim off the braided shield using scissors.

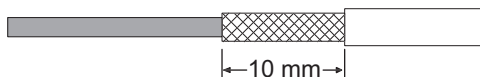

- 4** Remove the insulation from each conductor using a stripper.

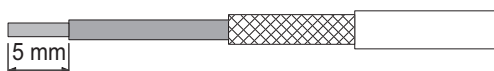

- 5** Fold back the braided shield.



- 6** Wrap an aluminum foil tape around the folded shield.

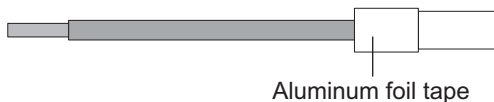

● Soldering

- 1** Place a heat-shrinking tube on each conductor.
- 2** Temporarily solder each conductor to the corresponding connector terminals.
- 3** Completely solder each conductor.

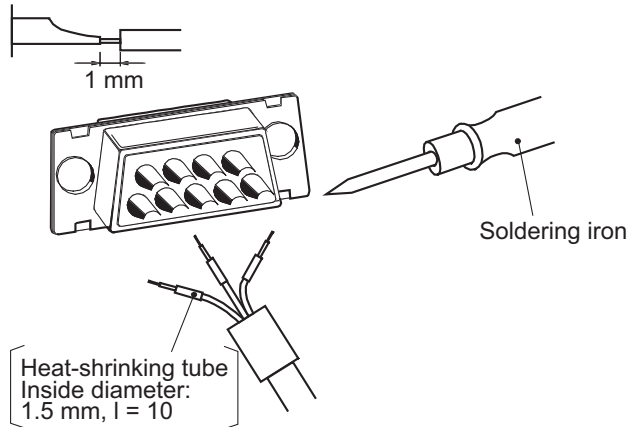

- 4** Return the heat-shrinking tube to the soldered portion, then heat the tube to shrink it with a heat gun.

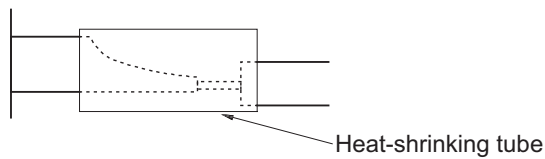

● Assembling Connector Hood

Assemble the connector hood as shown below.

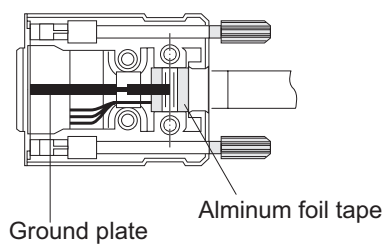

5-4-11 Wiring the NX1W-CIF11/-CIF12 Serial Communications Option Board

Recommended RS-422A/485 Wiring

Use the following wiring methods for RS-422A/485 to maintain transmission quality.

● Wire and Ferrule

Attach a ferrule to a wire, or use a solid wire.

Do not connect bare stranded wires directly to terminals.

The recommended solid wire specification and ferrule are given below.

Recommended RS-485 Cables

Model numbers	Manufacturer
CO-HC-ESV-3P×7/0.2	Hirakawa Hewtech Corp.

Recommended ferrules

Manufacturer	Model numbers	Applicable wire
Phoenix Contact	AI-0.25-12	AWG24

● Wiring

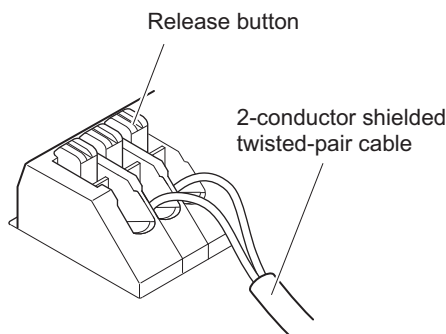

- To make the connection, insert the ferrule into the terminal hole on the terminal block. Insert the ferrule until it is locked inside.
- To disconnect the wiring, press the release button in with a small flat-blade screwdriver and pull the line out while the lock is released.

The following are the recommended screwdrivers to use to remove wires.

Recommended screwdriver model

Model	Manufacturer
SZS 0,4×2,5	Phoenix Contact
SZF 0-0,4×2,5*1	
ESD 0.40×2.5	Wera
0,4×2,5×75 302	Wiha
AEF.2,5×75	Facom
210-719	Wago

Model	Manufacturer
SDI 0.4×2.5×75	Weidmuller

- *1. You can purchase the SZF 0-0,4×2,5 screwdriver (manufactured by Phoenix Contact) from OMRON by specifying the OMRON's model number (XW4Z-00B).

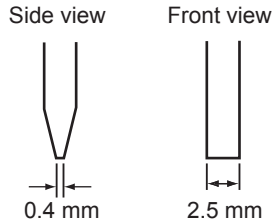

Precautions for Correct Use

- Use the NX1W-CIF11 (non-isolated type) only when there is no difference in electrical potential between device grounding points. Do not allow the communications distance to exceed 50 m. Connect the shield on the communications cable at both ends to the SHLD or FG terminals on the RS-422A/485 terminal blocks to ground it.
- Use the NX1W-CIF12 (isolated type) if there is a difference in electrical potential between device grounding points or for long distance communications (500 m max.). Connect the shield on the communications cable only at the Option Board to ground it. If the shield is connected at both ends of the cable when there is a difference in electrical potential, the devices may be damaged.

● **Connection Examples: Two-wire and Four-wire Transmission Circuits**

The transmission circuits for two-wire and four-wire connections are different, as shown in the following diagram.

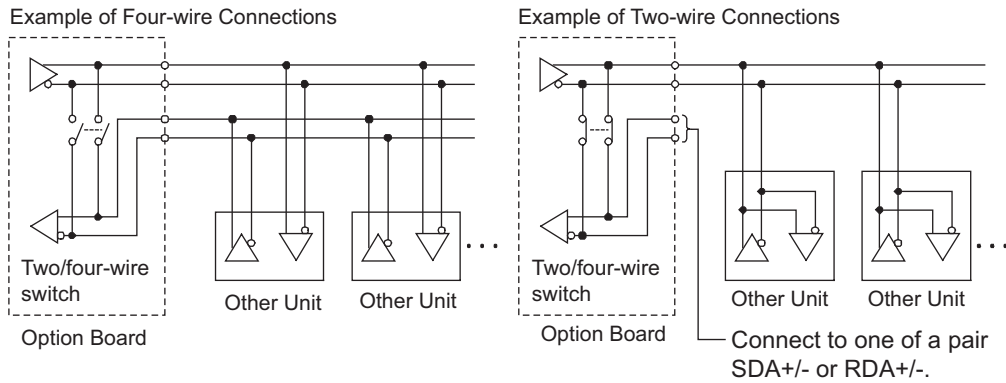

Set a terminating resistance if it is the end of transmission circuit.



Precautions for Correct Use

- Use the same type of transmission circuit (two-wire or four-wire) for all nodes.
- Do not use four-wire connections when the two/four-wire switch on the Board is set to two-wire.
- Always install a terminating resistance on the last RS-422A/485 node. Refer to the *NX-series NX1P2 CPU Unit Built-in I/O and Option Board User's Manual (Cat. No. W579)* for details on the wiring example of a terminating resistance.

● **Wiring Example: 1:1 Connections**

a. Two-wire Connections

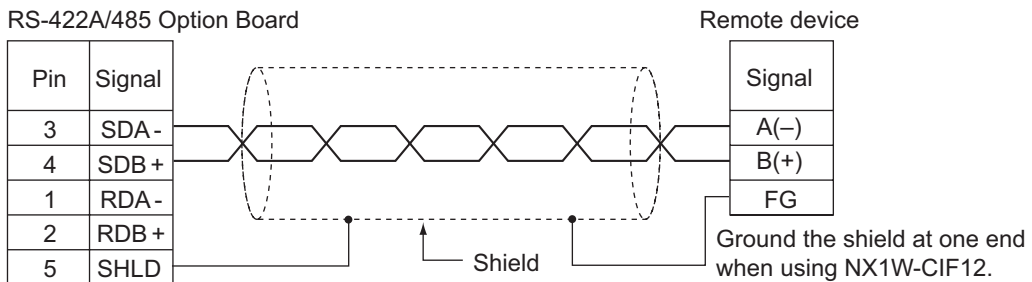

b. Four-wire Connections

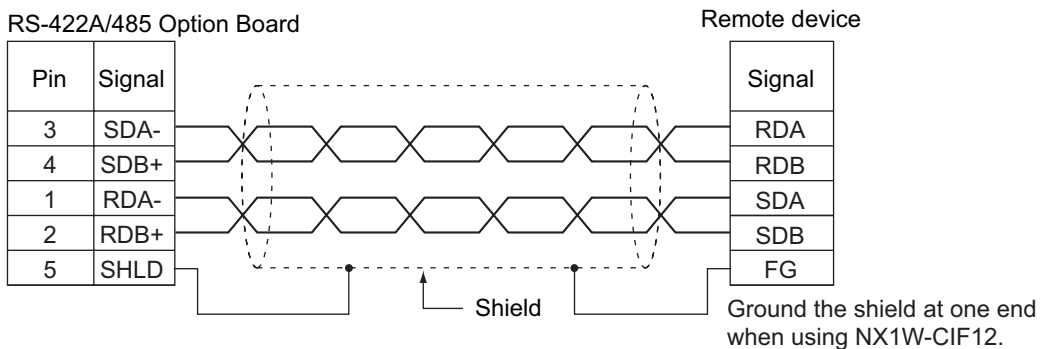

5-4-12 Wiring the Analog I/O Option Board

This section explains the wiring of an NX1W-ADB21/-DAB21V/-MAB221 Analog I/O Option Board. An Analog I/O Option Board provides analog input and analog output. For all models, the same method is used to connect analog input and analog output. Refer to *3-4 Analog I/O Option Board* on page 3-26 for the terminal arrangement for each model of the Analog I/O Option Board.

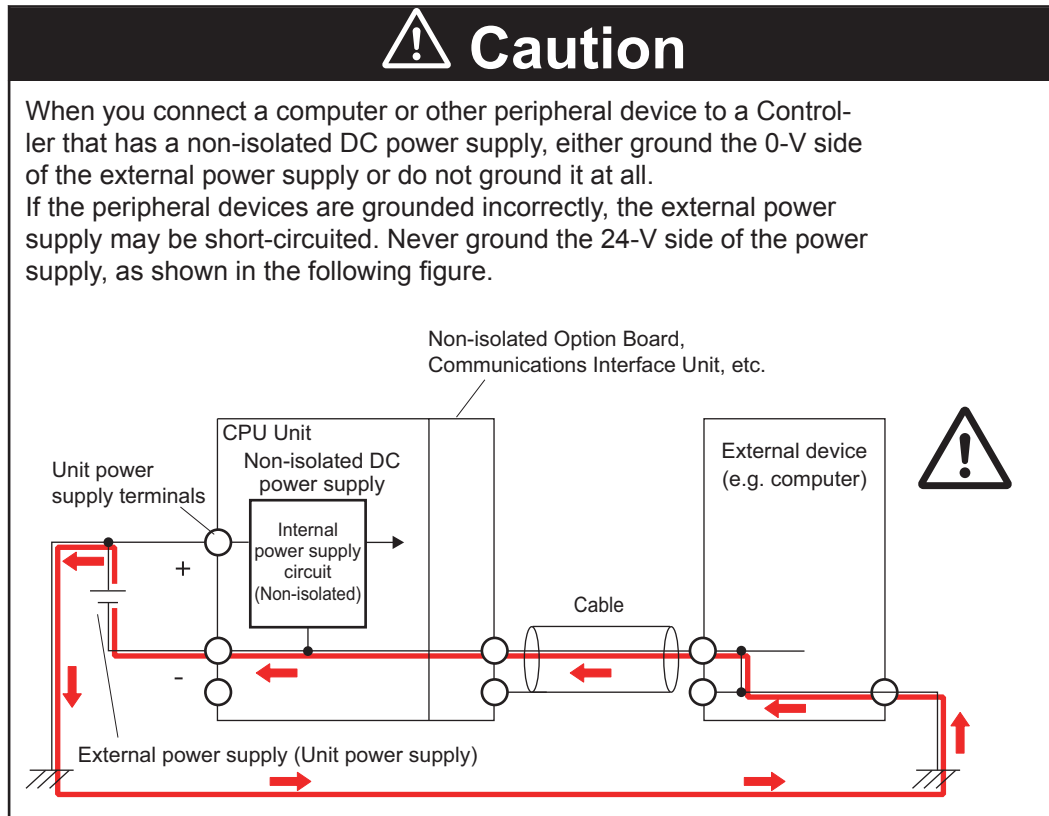

Internal Circuits

● Analog Input

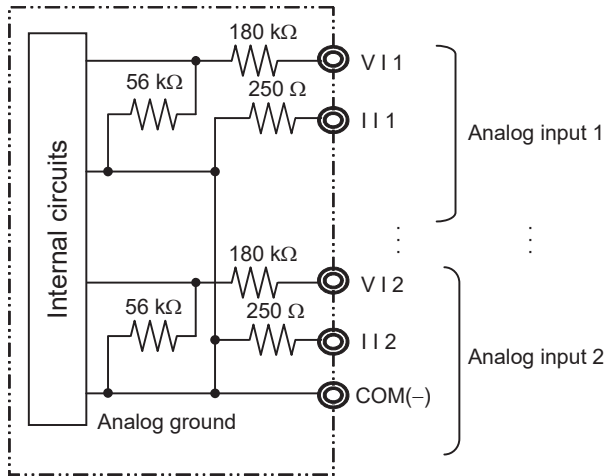

● Analog Output

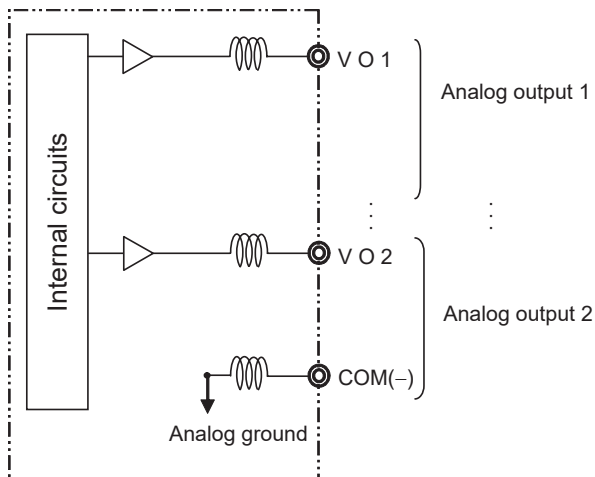

Terminal Block Wiring

● Wire and Ferrule

Attach a ferrule to a wire, or use a solid wire.

Do not connect bare stranded wires directly to terminals.

The recommended solid wire specification and ferrule are given below.

Recommended solid wire

Wire type	Wire size
Solid Wire	0.2 mm ² to 0.5 mm ² (AWG24 to AWG20)

Recommended ferrule

Manufacturer	Model	Applicable wire
Phoenix Contact	AI0,25-12	0.2 mm ² (AWG24)

● Terminal Wiring

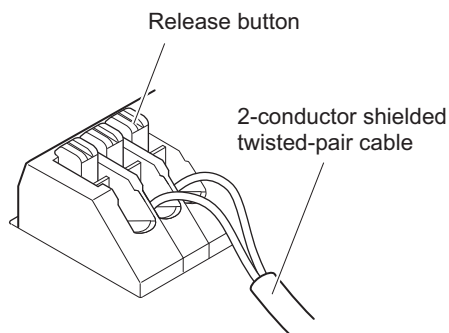

- To make the connection, insert the ferrule into the terminal hole on the terminal block. Insert the ferrule until it is locked inside.
- To disconnect the wiring, press the release button in with a small flat-blade screwdriver and pull the line out while the lock is released.

The screwdriver shown below is recommended for wiring.

Recommended screwdriver model

Model	Manufacturer
SZS 0,4×2,5	Phoenix Contact
SZF 0-0,4×2,5 ^{*1}	
ESD 0.40×2.5	Wera
0,4×2,5×75 302	Wiha
AEF.2,5×75	Facom
210-719	Wago
SDI 0.4×2.5×75	Weidmuller

*1. You can purchase the SZF 0-0,4×2,5 screwdriver (manufactured by Phoenix Contact) from OMRON by specifying the OMRON's model number (XW4Z-00B).

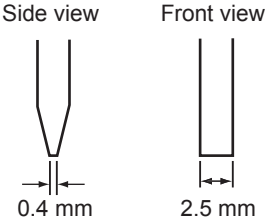

Wiring for Analog Inputs and Outputs

To prevent noise, 2-core shielded twisted-pair cable (AWG20 to AWG26) should be used.

● Wiring for Analog Inputs

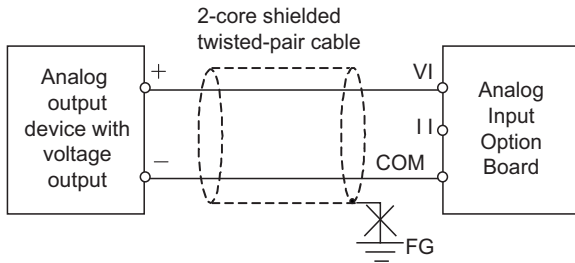

Voltage input

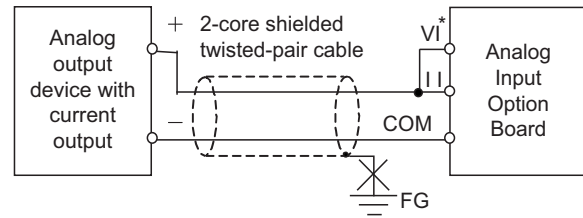

Current input

* When using current input, short-circuit the VI terminal (voltage input) and the II terminal (current input) of the Analog Input Option Board.

However, if noise affects the Unit, ground the end of the shield on the Input Unit side. You can use the NX-TBX01 Shield Connection Unit to ground more than one shield.



Precautions for Correct Use

- When you do not use some inputs, be sure to short-circuit the VI input terminals with the COM terminal.
- Separate the lines from power lines (e.g., AC power supply lines or power lines).

● Wiring for Analog Outputs

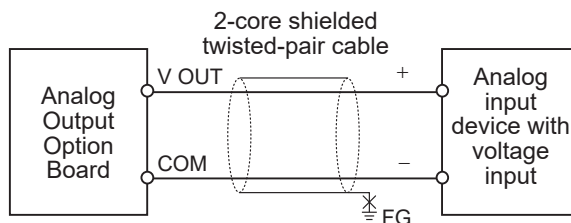

Precautions for Correct Use

To ensure this Option Board is kept in the best operating condition, observe the following points when wiring to avoid the effects of the noise.

- Use a shield wire (2 conductors, twisted wire) or a shield wire (3 conductors) as the input connection line for each output. Connect the shield according to the specifications of the input device.
- Wire the output connection lines and power lines (e.g., AC power supply lines or power lines) separately. Do not place such lines in the same duct.
- Insert a noise filter into the power supply input section if noise comes from power supply lines when using the same power supply to power an electrical welder or an electric discharge machine, or there is a high-frequency source nearby.



Additional Information

When external power is supplied, or when the power is interrupted, there may be a pulse status analog output of up to 1 ms. If this status is a problem, take the following measures.

- Turn ON the power to the CPU Unit, check the operation status, and then turn ON the power at the load.
 - Turn OFF the power to the load and then turn OFF the power to the Unit.
-

5-5 Control Panel Installation

To ensure system reliability and safety, the system must be designed and configured according to the installation environment (temperature, humidity, vibration, shock, corrosive gases, overcurrent, noise, etc.).

5-5-1 Temperature

Panels have been reduced in size due to space-saving and miniaturization in devices and systems, and the temperature inside the panel may be at least 10 to 15°C higher than outside the panel. Implement the following measures against overheating at the installation site and in the panel, and allow a sufficient margin for the temperature before use.

High Temperatures

Use the following cooling methods as required, taking into account the ambient temperature and the amount of heating inside the panel.

● Natural Cooling

- Natural cooling relies on natural ventilation through slits in the panel, rather than using cooling devices such as fans or coolers. When using this method, observe the following points.
- Do not install the Controller at the top of the panel, where hot air tends to stagnate.
- To provide ventilation space above and below the Controller, leave sufficient distance from other devices, wiring ducts, etc.
- Do not mount the Units in the wrong direction (e.g., vertically or upside down). Doing so may cause abnormal heating in the Controller.
- Do not install the Controller directly above any heat-generating equipment, such as heaters, transformers, and devices with high resistance.
- Do not install the Controller in a location exposed to direct sunlight.

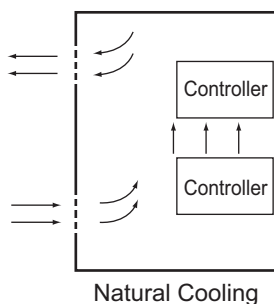

- **Forced Ventilation (by Fan at Top of Panel)**

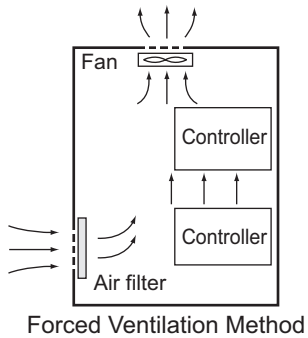

- **Forced Air Circulation (by Fan in Closed Panel)**

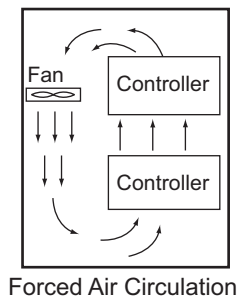

- **Room Cooling (Cooling the Entire Room Where the Control Panel Is Located)**

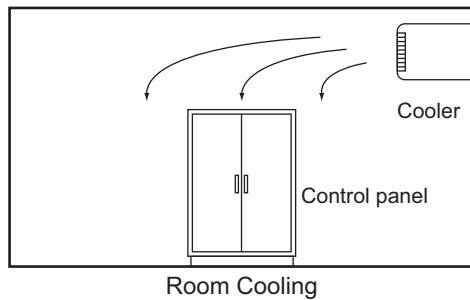

Low Temperatures

The Controller may not start normally if the temperature is below 0°C when the power is turned ON. Maintain an air temperature of at least approximately 5°C inside the panel, by implementing measures such as installing a low-capacity space heater in the panel. Alternatively, leave the Controller power ON to keep the Controller warm.

5-5-2 Humidity

Rapid temperature changes can cause condensation to occur, resulting in malfunctioning due to short-circuiting.

When there is a possibility of this occurring, take measures against condensation, such as leaving the Controller power ON at night or installing a heater in the control panel to keep it warmer.

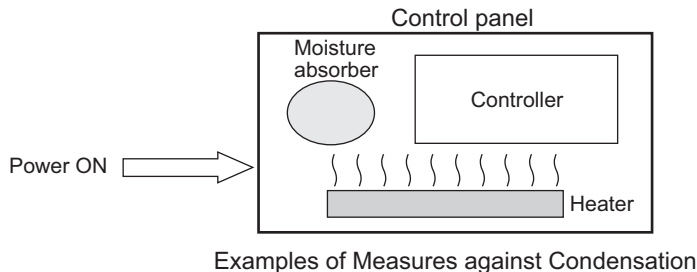

5-5-3 Vibration and Shock

The Controller is tested for conformity with the sine wave vibration test method (IEC 60068-2-6) and the shock test method (IEC 60068-2-27) of the Environmental Testing for Electrotechnical Products. It is designed so that malfunctioning will not occur within the specifications for vibration and shock. If, however, the Controller is to be used in a location in which it will be directly subjected to regular vibration or shock, then implement the following countermeasures:

- Separate the control panel from the source of the vibration or shock.
Or secure the Controller and the panel with rubber padding to prevent vibration.
- Make the building or the floor vibration-resistant.
- To prevent shock when other devices in the panel such as electromagnetic contactors operate, secure either the source of the shock or the Controller with rubber padding.

5-5-4 Atmosphere

Using the Controller in any of the following locations can cause defective contact with connectors and corrosion of components. Implement countermeasures such as purging the air as required.

- In locations exposed to dust, dirt, salt, metal powder, soot, or organic solvents, use a panel with an airtight structure. Be careful of temperature increases inside the panel.
- In locations exposed to corrosive gas, purge the air inside the panel to clear the gas and then pressurize the inside of the panel to prevent gas from entering from outside.
- In locations where flammable gas is present, either use an explosion-protected construction or do not use the Controller.

5-5-5 Electrical Environment

When installing or wiring devices, make sure that there will be no danger to people and that noise will not interfere with electrical signals.

Controller Installation Location

Install separately the Controller from high-voltage (600 V or higher) and power devices to ensure safe operation and maintenance. Install the Controller as far away as possible in case of unavoidable circumstances.

Example of Recommended Equipment Arrangement

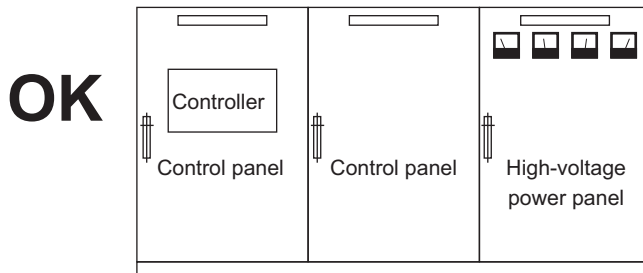

Example of Poor Equipment Arrangement

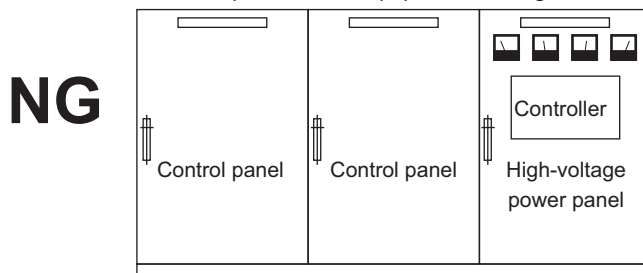

Examples of Equipment Arrangement in Panel with High-voltage Devices

Arrangement of Controller and Units

The coils and contacts in electromagnetic contacts and relays in an external circuit are sources of noise. Do not install them close to the Controller. Locate them at least 100 mm away from the Controller.

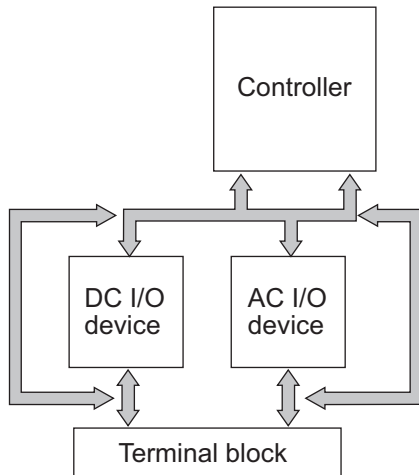

Example of Arrangement in Panel

Wire Layout for the Power Supply System

Observe the following points when wiring the power supply system.

- Separate the Controller power supply from the I/O device power supply and install a noise filter near the Controller power supply feed section.
- Use an isolating transformer to significantly reduce noise between the Controller and the ground. Install the isolating transformer between the Controller power supply and the noise filter, and do not ground the secondary coil of the transformer.
- Keep the wiring between the transformer and the Controller as short as possible, twist the wires well, and keep the wiring separate from high-voltage and power lines.

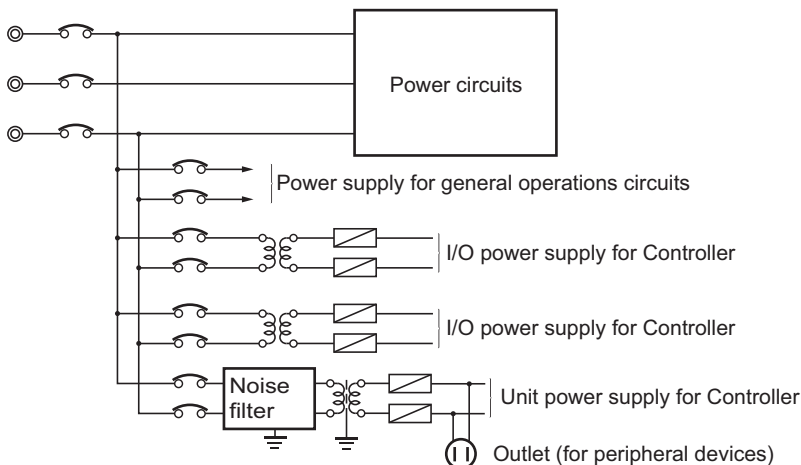

Power Supply System Diagram

Wiring External I/O Signal Lines

Observe the following points when wiring external I/O signal lines.

- To absorb reverse electromotive force when an inductive load is connected to an output signal, connect a surge suppressor near the inductive load in an AC circuit, or connect a diode near the inductive load in a DC circuit.

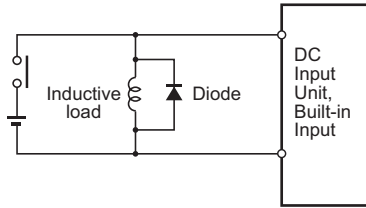

Connect a diode in a DC circuit.

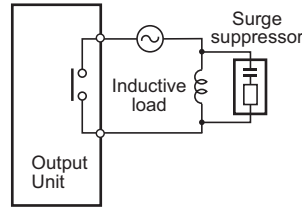

Connect a surge suppressor in an AC circuit.

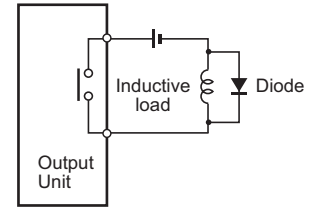

Connect a diode in a DC circuit.

Input Signal Noise Countermeasures

Output Signal Noise Countermeasures

- Never bundle output signal lines with high-voltage or power lines, and do not route them in close proximity or parallel to such lines.
If output signal lines must be routed in close proximity to such lines, place them in separate ducts or conduits. Be sure to ground the ducts or conduits.

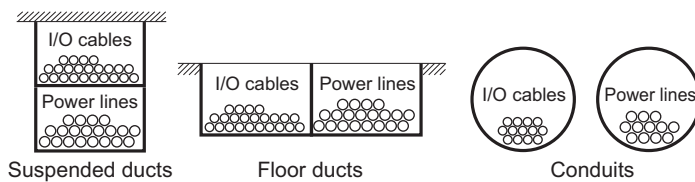

Suspended ducts

Floor ducts

Conduits

I/O Cable Arrangement

- If the signal lines and power lines cannot be routed in separate ducts, use shielded cable. Connect the shield to the ground terminal at the Controller, and leave it unconnected at the input device.
- Wire the lines so that common impedance does not occur.
Such wiring will increase the number of wires, so use common return circuits.
Use thick wires with sufficient allowance for the return circuits, and bundle them with lines of the same signal level.
- For long I/O lines, wire the input and output signal lines separately.
- Use twisted-pair wires for pilot lamps (and particularly lamps with filaments).
- Use countermeasures, such as CR surge absorbers and diodes, for input device and output load device noise sources, as required.

External Wiring

Wiring, and noise countermeasures in particular, are based on experience, and it is necessary to closely manage wiring based on experience and information in the manuals.

● Wiring Routes

Each of the following combinations includes different signal types, properties, or levels. They will cause the signal-to-noise ratio to drop due to factors such as electrical induction. As a general rule when wiring, either use separate cables or separate wiring routes for these items. Future maintenance operations and changes to the system will also be made easier by carefully organizing the wiring from the start.

- Power lines and signal lines
- Input signals and output signals
- Analog signals and digital signals
- High-level signals and low-level signals

- Communications lines and power lines
- DC signals and AC signals
- High-frequency devices (such as Inverters) and signal lines (communications)

● Wiring

Observe the following points when wiring power supply and signal cables.

- When routing signal cables with differing characteristics through the same duct, always keep them separated.
- As much as possible, avoid routing multiple power supply lines through the same duct. If it cannot be avoided, then construct a partition between them in the duct and ground the partition.

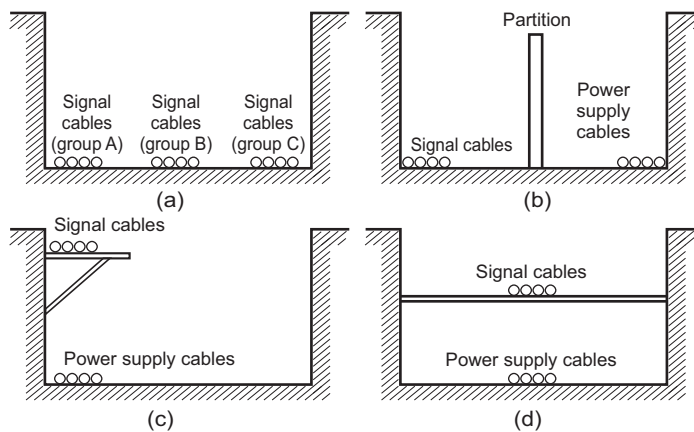

Partitioning Methods for Signal and Power Supply Cables

- To avoid overheating the conduits when using conduits for wiring, do not place wires for a single circuit in separate conduits.

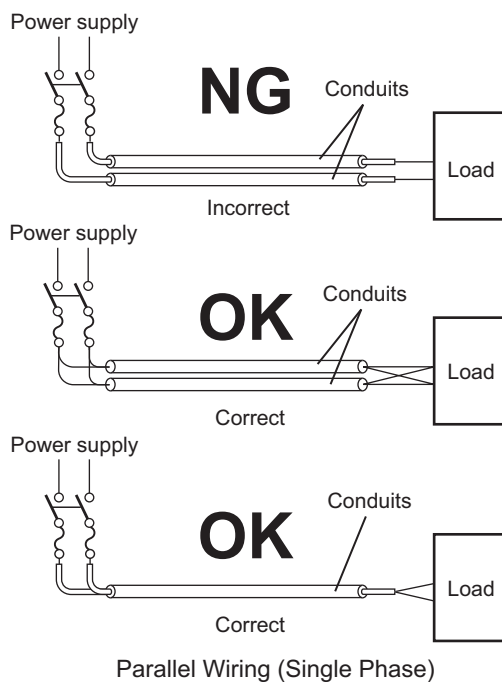

- Power cables and signal cables adversely affect each other. Do not wire them in parallel.

- Noise induction may occur if the Controller is installed in a panel that includes high-voltage devices. Wire and install them as far apart as possible. (Refer to *Controller Installation Location* on page 5-84.)
- Either install the Controller a minimum of 200 mm away from high-voltage lines or power lines, or place the high-voltage lines or power lines in metal tubing and completely ground the metal tubing to 100 Ω or less.

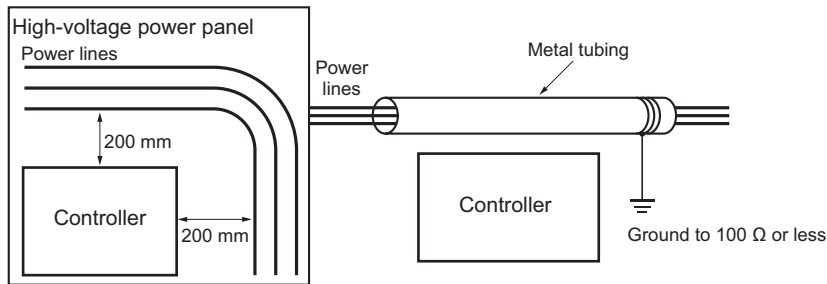

Example: Separating Controller from Power Lines

● Other Precautions

- Digital I/O Units have both plus and minus commons, so pay attention to the polarity when wiring.

5-5-6 Grounding

This section describes the earthing methods and precautions.

Considerations for Earthing Methods

Local potential fluctuations due to lightning or noise occurred by power devices will cause potential fluctuations between ground terminals of devices. This potential fluctuation may result in device malfunction or damage. To prevent this, it is necessary to suppress the occurrence of a difference in electrical potential between ground terminals of devices. You need to consider the earthing methods to achieve this objective.

The recommended earthing methods for each usage condition are given in the following table.

Specification of communications cables for EtherCAT and EtherNet/IP	Earthing methods			
	Equipotential bonding system	Star earthing		Daisy chain
		Connecting devices and noise sources to separate earth electrodes	Connecting devices and noise sources to a common earth electrode	
The cable shield connected to the connector hood at both ends of the communications cable	Recommended	Recommended	Not recommended	Not recommended
Neither EtherCAT nor EtherNet/IP used	Recommended	Recommended	Not recommended	Not recommended



Additional Information

- In a country or region where the earthing method is regulated, you must comply with the regulations. Refer to the applicable local and national ordinances of the place where you install the system, or other international laws and regulations.
- For details on wiring EtherCAT or EtherNet/IP, refer to the *NJ/NX-series CPU Unit Built-in EtherCAT Port User's Manual* (Cat. No. W505) or the *NJ/NX-series CPU Unit Built-in EtherNet/IP Port User's Manual* (Cat. No. W506).
- Ethernet switches are used with the EtherNet/IP. For information on the environmental resistance of the Ethernet switch to use, the grounding between Ethernet switches, or the specifications of cables, ask the Ethernet switch manufacturer.

Each of these earthing methods is given below.

● Equipotential Bonding System

Equipotential bonding is an earthing method in which steel frames and building structures, metal ducts and pipes, and metal structures in floors are connected together and make connections to the earth trunk line to achieve a uniform potential everywhere across the entire building. We recommend this earthing method.

The following figure shows an example of an equipotential bonding system.

Connect the main earthing terminal and building structures together with equipotential bonding conductors and embed the mesh ground line in each floor.

Connect the ground line of each control panel to the equipotential bonding system.

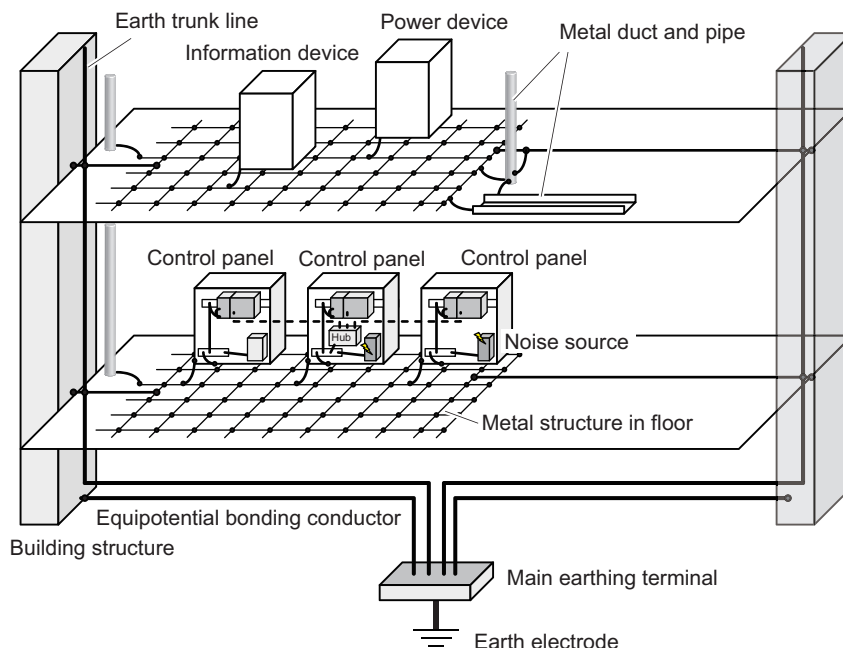

● Star Earthing

If the earthing method used for the building is not equipotential bonding or the earthing system is unknown, choose (a) from among the earthing methods given below.

- Connecting devices and noise sources to separate earth electrodes

This is an earthing method to separately ground an earth electrode of the device that is connected with a communications cable or other devices and an earth electrode of a high-power

device that could be a noise source, such as a motor or inverter. Each earth electrode must be ground to 100 Ω or less.

Connect the ground lines of the device that is connected with a communications cable and other devices as a bundle to a single earth electrode. Be sure that the earth electrode is separated by a minimum of 10 m from any other earth electrode of a device that could be a noise source.

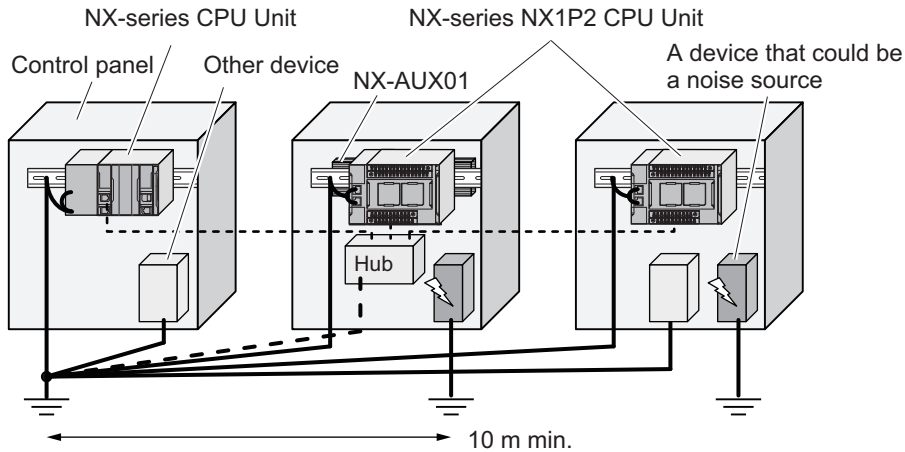

b. Connecting devices and noise sources to a common earth electrode

This is an earthing method to connect the device that is connected with a communications cable, other devices, and a device that could be a noise source, to a common earth electrode. This earthing method is not recommended because the device that could be a noise source may interfere electromagnetically with other devices.

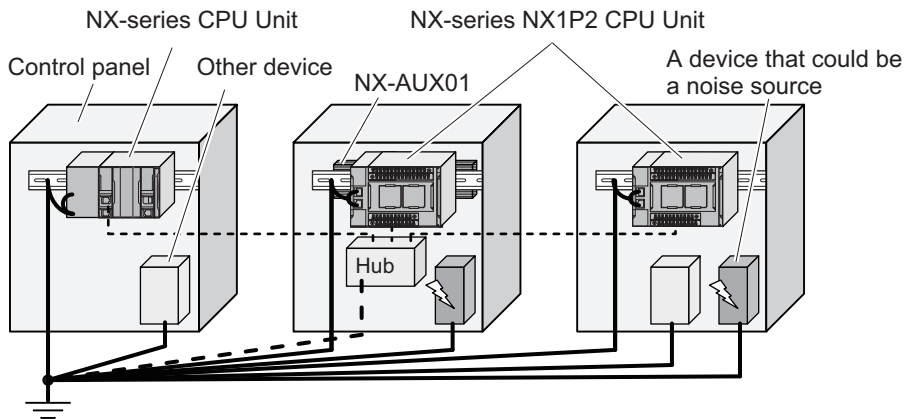

● Daisy Chain

This is an earthing method to connect the device that is connected with a communications cable, other devices, and a device that could be a noise source using a daisy-chain topology to a common earth electrode.

This earthing method is not recommended because the device that could be a noise source may interfere electromagnetically with other devices.

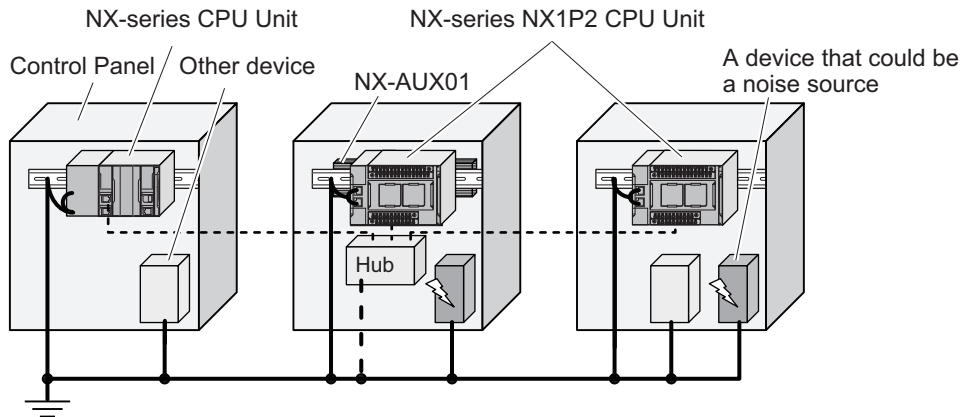

Precautions for Grounding

● General Precautions

- To prevent electrical shock, do not connect devices to ground poles (or steel frames) with non-equalized potential to which multiple devices are connected.
- Use a ground pole as close to the Controller as possible and keep the ground line as short as possible.
- If the same ground is used for both the signal lines and the enclosure, isolate the channel base (a grounded metal plate inside a control panel) with an insulating material.
Refer to *Isolating the CPU Rack from the Control Panel* on page 5-48 for how to isolate the CPU Rack of an NX1P2 CPU Unit.

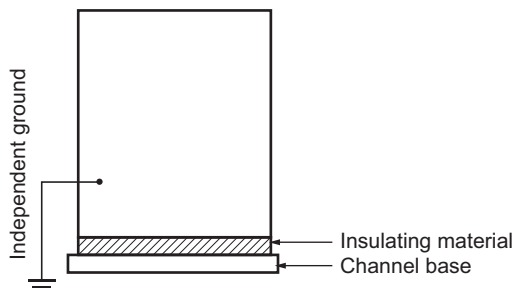

Example: Insulating and Grounding an Enclosure

- If high-frequency equipment is present, then ground not only the high-frequency equipment but also the panel in which the Controller is housed.
- As shown in the following diagram, when using shielded cable for I/O wiring, connect the shield near the Controller to the enclosure ground terminal.
Follow the instructions in the Communications Unit manual for preparing shielded communications cable.

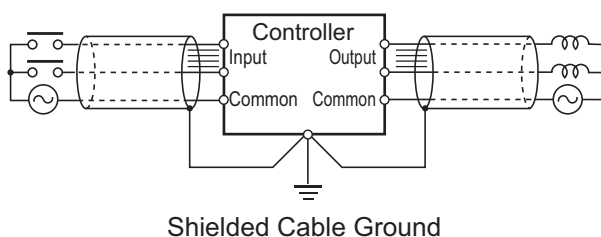

Shielded Cable Ground

● Controller Ground Terminals

The Controller has the following ground terminal.

Grounding type	Symbol	Connection
Functional Grounding		Ground this terminal when power supply noise causes malfunctioning.

When the functional ground terminal is correctly grounded, it is generally effective in suppressing power supply common noise. Occasionally, however, grounding this terminal will result in picking up more noise, so be careful when using it.



Troubleshooting

This section describes the overview of the methods for checking errors.

6-1	Overview of Troubleshooting.....	6-2
-----	----------------------------------	-----

6-1 Overview of Troubleshooting

You manage all of the errors that occur on the NJ/NX-series Controller as events.

This allows you to see what errors have occurred and find corrections for them with the same methods for the entire range of errors that is managed (i.e., CPU Unit, NX Units, NX-series Slave Terminals, EtherCAT slaves,^{*1} and CJ-series Units).

*1. Only Sysmac devices are supported.

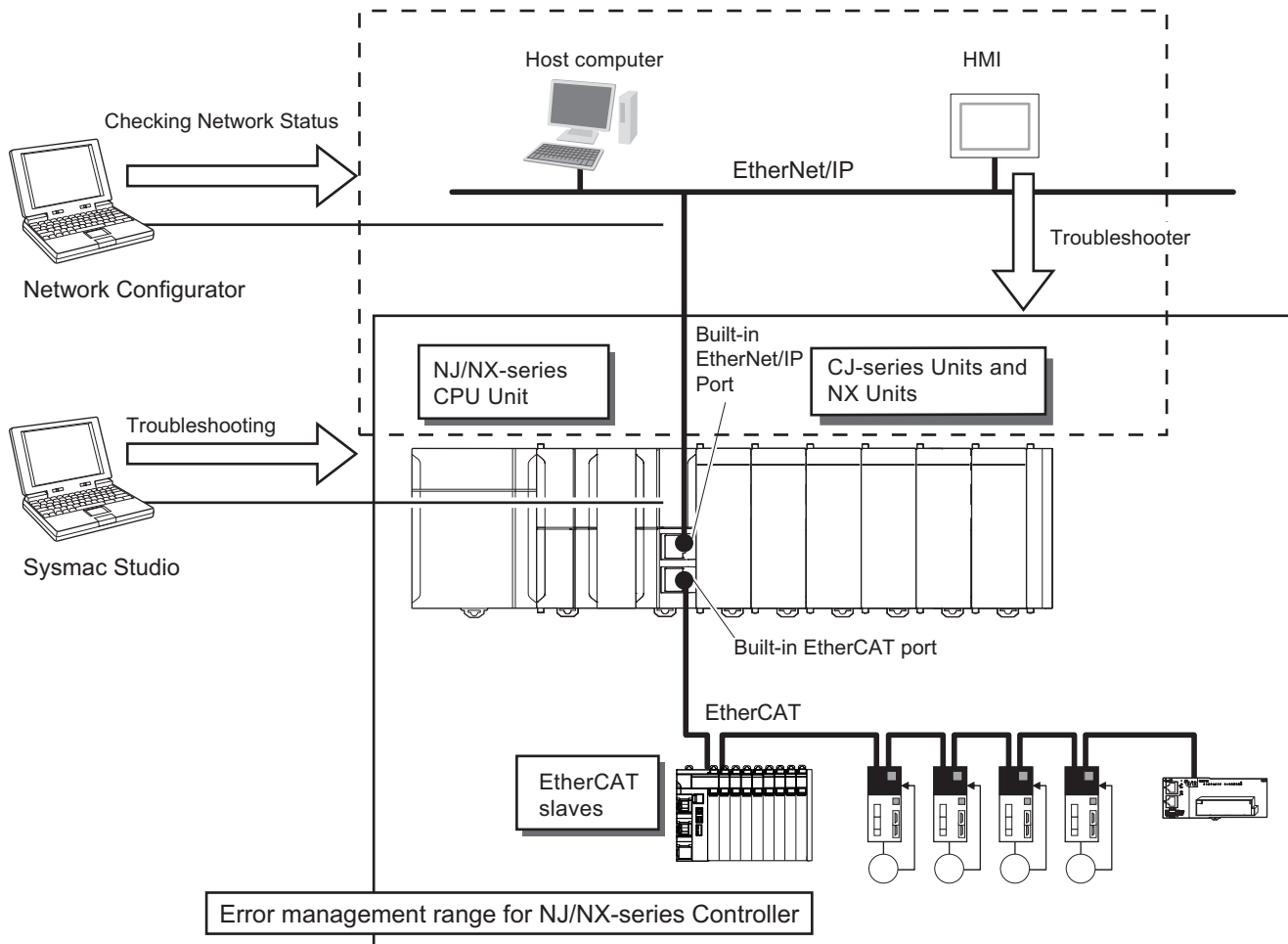

You can use the troubleshooting functions of the Sysmac Studio or the Troubleshooter on an HMI to quickly check for errors that have occurred and find corrections for them.

Refer to the *NJ/NX-series Troubleshooting Manual (Cat. No. W503-E1-19 or later)* for error types and details, specific corrections when errors occur, and troubleshooting information on the entire NJ/NX-series Controllers.

7

Inspection and Maintenance

This section describes the required inspections and maintenance. It also describes the service life and replacement procedure for the Battery.

7-1	Cleaning and Maintenance	7-2
7-1-1	Cleaning	7-2
7-1-2	Periodic Inspections	7-3
7-1-3	Unit Replacement Precautions	7-4
7-2	Replacing the Battery	7-6

7-1 Cleaning and Maintenance

This section describes daily maintenance and the cleaning and inspection methods.

Daily or periodic inspections are required in order to maintain the NX-series NX1P2 CPU Unit's functions in peak operating condition.

7-1-1 Cleaning

Perform the following cleaning procedures periodically to ensure the NX-series CPU Unit is maintained in the best operating condition. Always turn OFF the power supply to the Controller before performing the cleaning procedures.

- Wipe off the dust or dirt on the front, top or bottom of the Unit over with a dry, soft cloth when doing daily cleaning.
- If dust or dirt remains even after wiping with a soft, dry cloth, wipe over with a cloth that has been wet with a sufficiently diluted detergent (2%) and wrung dry.
- A smudge may remain on the Unit from gum, vinyl, or tape that was left on for a long time. Remove the smudge when cleaning.



Precautions for Correct Use

- Never use volatile solvents, such as paint thinner, benzene, or chemical wipes.
 - Do not touch the connectors.
-

7-1-2 Periodic Inspections

Although the major components in NX-series Controllers have an extremely long life time, they can deteriorate under improper environmental conditions. Periodic inspections are thus required to ensure that the required conditions are being kept.

Inspection is recommended at least once every six months to a year, but more frequent inspections may be necessary depending on the severe environments.

Take immediate steps to correct the situation if any of the conditions in the following table are not met.

Periodic Inspection Items

No.	Inspection item	Inspection details	Criteria	Correction
1	External power supply	Check for voltage fluctuations at the power supply terminals.	The voltage must be within the allowable voltage fluctuation range.	Use a voltage tester to check the power supply at the terminals. Take necessary steps to bring voltage of the supplied power to within the allowable voltage fluctuation range.
2	I/O power supply	Check for voltage fluctuations at the I/O terminals.	Voltages must be within specifications for each Unit.	Use a voltage tester to check the I/O power supply at the terminals. Take necessary steps to bring voltage fluctuations within limits.
3	Ambient environment	Check the ambient temperature. (Inside the control panel if the Controller is in a control panel.)	0 to 55°C	Use a thermometer to check the temperature and ensure that the ambient temperature remains within the allowed range of 0 to 55°C.
		Check the ambient humidity. (Inside the control panel if the Controller is in a control panel.)	Relative humidity must be 10% to 95% with no condensation.	Use a hygrometer to check the humidity and ensure that the ambient operating humidity remains between 10% and 95%. Make sure that condensation does not occur due to rapid changes in temperature.
		Check that the Controller is not in direct sunlight.	Not in direct sunlight	Protect the Controller if necessary.
		Check for accumulation of dirt, dust, salt, metal powder, etc.	No accumulation	Clean and protect the Controller if necessary.
		Check for water, oil, or chemical sprays hitting the Controller.	No spray	Clean and protect the Controller if necessary.
		Check for corrosive or flammable gases in the area of the Controller.	No corrosive or flammable gases	Check by smell or use a gas sensor.
		Check the level of vibration or shock.	Vibration resistance and shock resistance must be within specifications.	Install cushioning or shock absorbing equipment if necessary.
		Check for noise sources near the Controller.	No significant noise sources	Either separate the Controller and noise source or protect the Controller.

No.	Inspection item	Inspection details	Criteria	Correction
4	Installation and wiring	Check that the DIN Track mounting hooks on all Units are securely locked.	No looseness	Securely lock the DIN Track mounting hooks.
		Check that cable connectors are fully inserted and locked.	No looseness	Correct any improperly installed connectors.
		Check that the screws on the End Plates (PFP-M) are tight.	No looseness	Tighten loose screws with a Phillips-head screwdriver.
		Check that each Unit is connected along the hookup guides, and fully inserted until it contacts the DIN Track.	The Units must be connected and securely in place on the DIN Track.	Connect each Unit along the hookup guides, and insert each Units until it contacts the DIN Track.
		Check for damaged external wiring cables.	No visible damage	Check visually and replace cables if necessary.
5	User-serviceable parts	Battery Set CJ1W-BAT01 Check whether the battery has reached its service life.	Service life expectancy is 5 years at 25°C. Depending on model and ambient temperature.	Replace the battery when its service life has passed even if a battery error has not occurred. (Battery life depends upon the model, and ambient conditions.) Refer to <i>7-2 Replacing the Battery</i> on page 7-6 for the service life of individual model.

Tools Required for Inspections

● Required Tools

- Flat-blade screwdriver
- Phillips screwdriver
- Voltage tester or digital multimeter
- Industrial alcohol and pure cotton cloth
- Antistatic gas duster

● Tools Required Occasionally

- Oscilloscope
- Thermometer and hygrometer

7-1-3 Unit Replacement Precautions

If you find any faulty Unit after check, replace the Unit according to the following points.

- Do not replace a Unit until the power is turned OFF.
- Check the new Unit to make sure that there are no errors.
- If you return a faulty Unit for repair, describe the problem in as much detail as possible, enclose this description with the Unit before returning it.
- For poor contact, take a clean cotton cloth, soak the cloth in industrial alcohol, and carefully wipe the contacts clean. Be sure to remove any lint prior to remounting the Unit.



Precautions for Safe Use

- Make sure that the required data, including the user program, **configurations, settings** and variables is transferred to a CPU Unit that was replaced and to externally connected devices before restarting operation. Be sure to include the tag data link settings and routing tables, which are stored in the CPU Unit.
 - The absolute encoder home offsets are backed up in the CPU Unit as absolute encoder information. When you change the combination of the CPU Unit and Servomotor, e.g., when you add or replace a Servomotor, define the absolute encoder home again.
-



Precautions for Correct Use

If you replace a slave or Unit, refer to operation manual for the slave or Unit for information on the data required for individual slaves or Units and redo the necessary settings.

7-2 Replacing the Battery

The separately-sold Battery for clock is one of the NX-series components that require periodic replacement as preventive maintenance. This section describes how to replace the Battery.

Replacement Battery

Use the Battery CJ1W-BAT01 for replacement.



Precautions for Correct Use

Be sure to mount a Battery within two years of the production date shown on the Battery label.
Production Date



Manufactured in March 2018.

Replacement Procedure

Use the following procedure to replace the battery.



Precautions for Safe Use

We recommend mounting or replacing the Battery with the power OFF to prevent the CPU Unit's sensitive internal components from being damaged by static electricity. The Battery can be mounted or replaced without turning OFF the power supply. To do so, always touch a grounded piece of metal to discharge static electricity from your body before starting the procedure.

If the Low Battery Voltage error occurs after you mount the Battery, connect the Sysmac Studio and clear the error.



Additional Information

UL standards require that batteries be replaced by experienced technicians. Always place an experienced technician in charge of battery replacement.

- 1** Turn OFF the power supply to the Controller.
If the CPU Unit has not been ON, turn it ON for at least five minutes and then turn it OFF.



Additional Information

The CPU Unit has a built-in capacitor that retains the clock data during battery replacement or power interruptions.

If power is not turned ON for at least five minutes before replacing the battery, the built-in capacitor cannot be fully charged and the clock data may be lost during battery replacement.

- 2** Remove the battery cover.
Refer to *5-3-10 Battery Installation* on page 5-33 for how to remove it.

- 3 After removing an old battery, install a new battery.
- 4 Press in the battery harness and attach the battery cover.



Precautions for Safe Use

- Before you replace the Battery, you must first supply power to the Controller for at least 5 minutes, and then you must complete this procedure within 5 minutes at 25°C after turning OFF the power to the CPU Unit to ensure memory backup. If power is not supplied for at least 5 minutes, the retained clock data may be lost.
- Never short-circuit the battery terminals; never charge the battery; never disassemble the battery; and never heat or incinerate the battery. Doing any of these may cause the battery to leak, heat, ignite, or rupture.
- Never use a battery that has been dropped on the floor or otherwise subject to shock. It may leak.



Precautions for Correct Use

Turn ON the power after replacing the battery for a CPU Unit that has been unused for a long time. Leaving the CPU Unit unused again without turning ON the power even once after the Battery is replaced may result in a shorter Battery life.



Additional Information

The *Low Battery Voltage* event is cleared automatically the next time the Controller is turned ON after replacing the Battery.

Battery Service Life and Replacement Period

The service life of a battery is five years. Generally, the service life of a battery varies depending on the ambient temperature and the power ON time rate. The NX1P2 CPU Unit, due to low power consumption, ensures a battery life of 60 months (five years), which is equivalent to the battery service life.

Make a plan to replace the Battery so that the service life of the Battery will not exceed the minimum lifetime under the normal product usage condition.

The Battery service life when power ON time rate is 0% (i.e., power OFF)

Unit model number	Approx. minimum lifetime [month] ^{*1}		
	25°C	40°C	55°C
NX1P2-□□□□□□□□	60		

*1. This is the life expectancy which Omron guarantees, based on the calculation worst value of the part's specification of the product.

Low Battery Indicators

If the Controller Setup has been set to detect a low-battery error, the ERROR indicator on the front of the CPU Unit will flash when the battery is nearly discharged.

If the ERROR indicator flashes, connect the Sysmac Studio, and then check the CPU Unit's Battery connection if the Sysmac Studio shows a *Low Battery Voltage* or *Real-Time Clock Stopped* event. If the Battery is properly connected, replace the Battery with a new one as soon as possible.

Once a low-battery error has been detected, it will take 5 days (at an ambient temperature of 25°C) before the battery fails if power has been supplied at least once a day.

Clock data can be retained by ensuring that the CPU Unit power is not turned OFF until the Battery has been replaced.



Additional Information

The Battery will lose its charge faster at high ambient temperatures.



Appendices

The appendices provide the general specifications of the CPU Unit and Unit dimensions.

A-1	Specifications	A-2
A-2	Dimensions	A-3
A-2-1	NX-series NX1P2 CPU Units	A-3
A-2-2	End Cover	A-4
A-2-3	SD Memory Card	A-4
A-2-4	Option Boards	A-5
A-3	Version Information	A-6
A-3-1	Relationship between Unit Versions of CPU Units and Sysmac Studio Versions	A-6
A-3-2	Functions That Were Added or Changed for Each Unit Version	A-7
A-4	Support Functions of the CPU Units and Restrictions on the NX Units	A-9

A-1 Specifications

This section gives the general specifications that are common to NX-series NX1P2 CPU Unit and their relevant products.

For the electrical and mechanical specifications, refer to the Models and Specifications section for each product.

Item		Specification
Enclosure		Mounted in a panel
Grounding method		Ground to less than 100 Ω.
Operating environment	Ambient operating temperature	0 to 55°C
	Ambient operating humidity	10% to 95% (with no condensation)
	Atmosphere	Must be free from corrosive gases.
	Ambient storage temperature	-25 to 70°C (excluding battery)
	Altitude	2,000 m max.
	Pollution degree	2 or less: Meets IEC 61010-2-201.
	Noise immunity	2 kV on power supply line (Conforms to IEC 61000-4-4.)
	Overvoltage category	Category II: Meets IEC 61010-2-201.
	EMC immunity level	Zone B
	Vibration resistance	Conforms to IEC 60068-2-6. 5 to 8.4 Hz with 3.5-mm amplitude, 8.4 to 150 Hz, acceleration of 9.8 m/s ² 100 min each in X, Y, and Z directions (10 sweeps of 10 min each = 100 min total)
Shock resistance	Conforms to IEC 60068-2-27. 147 m/s ² , 3 times in X, Y, and Z directions	
Battery	Life	5 years (Power ON time rate 0% (power OFF))
	Model	CJ1W-BAT01 (sold separately)
Applicable standards*1	EU Directives	EN 61131-2
	cULus	Listed(UL 61010-2-201), ANSI/ISA 12.12.01
	Shipbuilding Standards	NK and LR
	Other than the above.	KC

*1. Refer to the OMRON website (<http://www.ia.omron.com/>) or consult your OMRON representative for the most recent applicable standards for each model.

A-2 Dimensions

Dimensions of the Units are shown as follows. The unit of dimension is millimeter.

A-2-1 NX-series NX1P2 CPU Units

NX1P2-□□40□□□

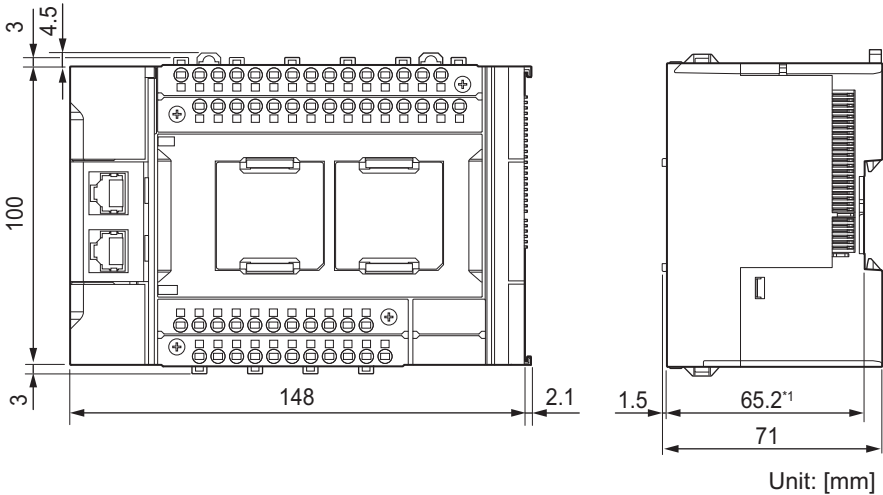

Unit: [mm]

*1. The dimension from the attachment surface of the DIN Track to the front surface of the CPU Unit.

NX1P2-9□24□□□

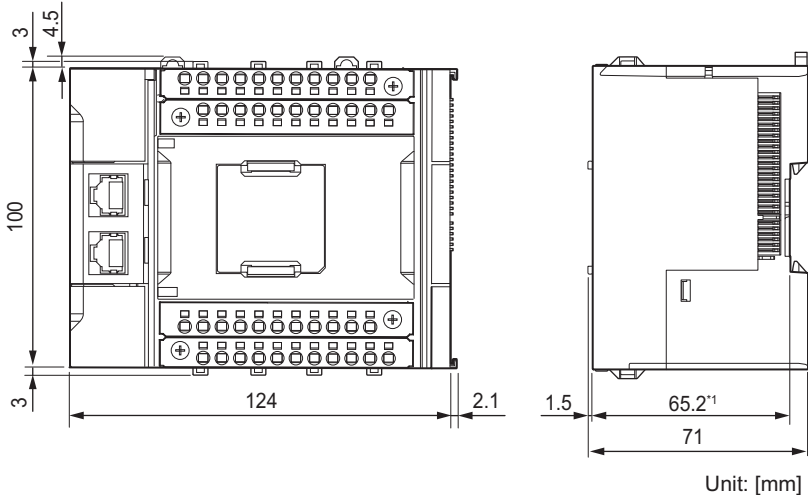

Unit: [mm]

*1. The dimension from the attachment surface of the DIN Track to the front surface of the CPU Unit.

For dimensions after attaching the communications cables and Option Boards, refer to 5-3-13 Assembled Appearance and Dimensions on page 5-38.

A-2 Dimensions

A

A-2-1 NX-series NX1P2 CPU Units

A-2-2 End Cover

NX-END02

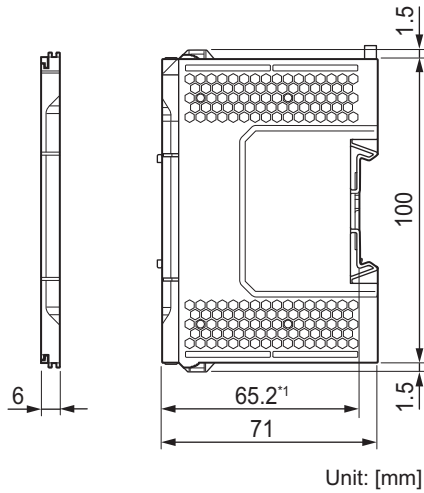

*1. The dimension from the attachment surface of the DIN Track to the front surface of the end cover.

A-2-3 SD Memory Card

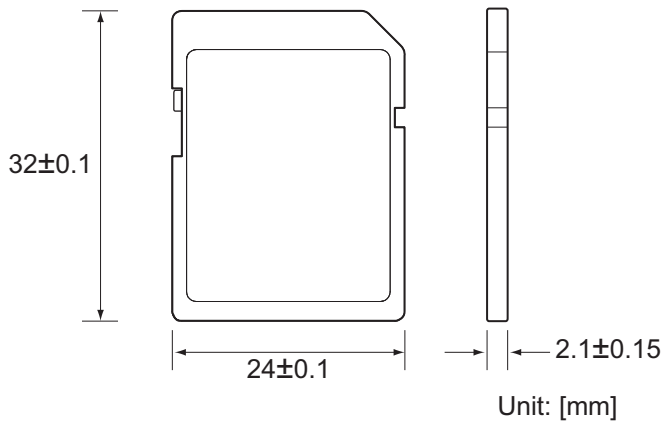

A-2-4 Option Boards

NX1W-CIF01

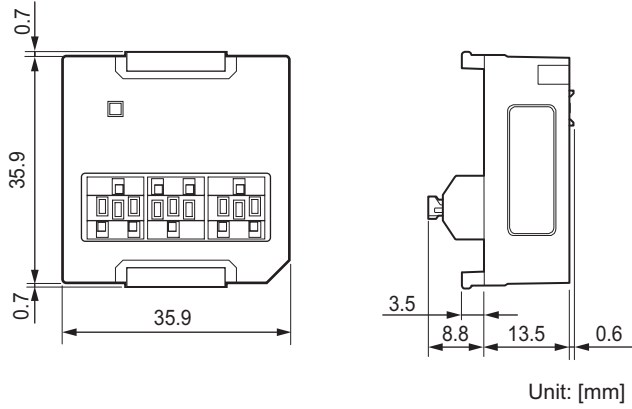

NX1W-CIF11/-CIF12

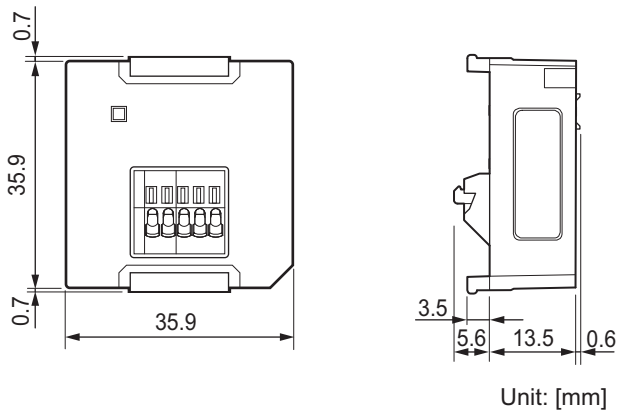

NX1W-ADB21/ -DAB21V/ -MAB221

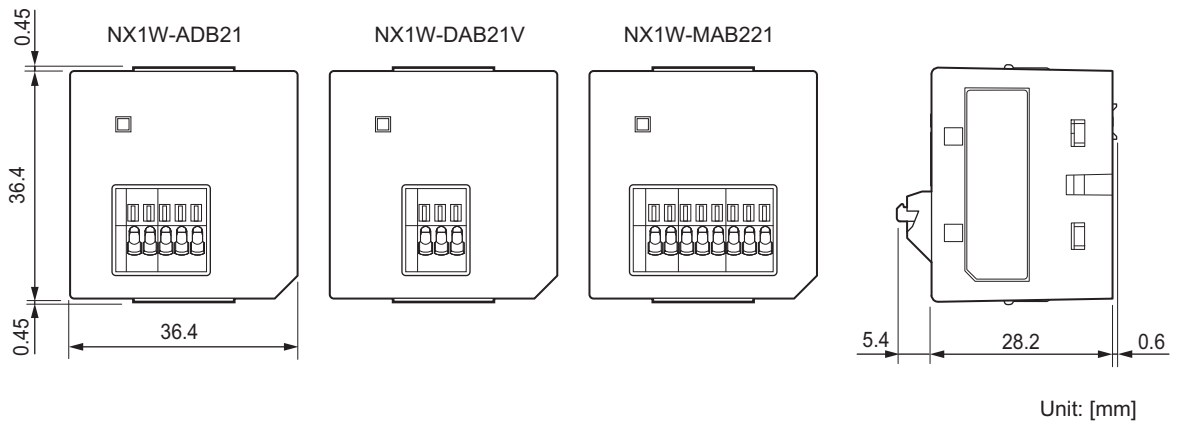

A-3 Version Information

This section describes the relationship between the unit versions of the NX-series NX1P2 CPU Unit and the Sysmac Studio versions, and the functions that are supported for each unit version.

Refer to the *A-4 Support Functions of the CPU Units and Restrictions on the NX Units* on page A-9 for information on NX Units that can be connected to the CPU Unit.

A-3-1 Relationship between Unit Versions of CPU Units and Sysmac Studio Versions

This section describes how the unit versions of NX-series NX1P2 CPU Unit and Option Boards correspond to Sysmac Studio versions.

Unit Versions and Corresponding Sysmac Studio Versions

This following table gives the relationship between the unit versions of NX-series NX1P2 CPU Units and Option Boards and the corresponding Sysmac Studio versions.

Unit version of CPU Unit	Unit version of Option Board	Corresponding version of Sysmac Studio
Ver.1.40 ^{*1}	Ver.1.00	Ver.1.30 ^{*2} Ver.1.29
Ver.1.21 ^{*3}	Ver.1.00	Ver.1.28
Ver.1.18 ^{*4}	Ver.1.00	Ver.1.22
Ver.1.16 ^{*5}	Ver.1.00	Ver.1.20
Ver.1.14	Ver.1.00	Ver.1.18
Ver.1.13 ^{*6}	Ver. 1.00	Ver. 1.17

*1. There is no NX1P2-□□□□□□□ CPU Unit with unit version 1.22 or later and unit version earlier than 1.40.

There is no NX1P2-9B□□□□□ CPU Unit with unit version earlier than 1.40.

*2. Use an NX1P2-9B□□□□□ CPU Unit with Sysmac Studio version 1.30 or higher.

You cannot use an NX1P2-9B□□□□□ CPU Unit with Sysmac Studio version 1.29 or lower.

*3. There is no NX1P2 CPU Unit with unit version 1.19 or later and unit version earlier than 1.21.

*4. There is no NX1P2 CPU Unit with unit version 1.17.

*5. There is no NX1P2 CPU Unit with unit version 1.15.

*6. There is no NX1P2 CPU Unit with unit version 1.12 or earlier.

Specifications When Not Using the Sysmac Studio Version That Corresponds to the Unit Version of the CPU Unit

The specifications when you do not use the Sysmac Studio version that corresponds to the unit version of the NX-series NX1P2 CPU Unit and Option Board are given in this section.

● Using Sysmac Studio Version 1.16 or Lower

You cannot use an NX-series NX1P2 CPU Unit with Sysmac Studio version 1.16 or lower.

● Using a Lower Version of Sysmac Studio

If you use a lower version of the Sysmac Studio, you can use only the functions of the unit version of the CPU Unit that corresponds to the Sysmac Studio version.

Example:

Unit version of CPU Unit: 1.14

Sysmac Studio version: 1.17

The unit version of the CPU Unit that corresponds to Sysmac Studio version 1.17 is unit version 1.13.

Therefore, you can use only the functions that are supported by a CPU Unit with a unit version of 1.13.

You cannot use functionality that was added for unit version 1.14 or later of the CPU Unit.

● Using a CPU Unit with an Earlier Unit Version

If you use an NX-series CPU Unit with an earlier version, select the unit version of the used CPU Unit or an earlier unit version in the Select Device Area of the Project Properties Dialog Box on the Sysmac Studio. The unit version that you selected is the project unit version of the project. You can use only the functions that are supported by the project unit version.

Example:

Unit version of CPU Unit: 1.14

Sysmac Studio version: 1.20

Unit version 1.16 of the CPU Unit corresponds to Sysmac Studio version 1.20.

However, the used CPU Unit is unit version 1.14, so select *version 1.14* or earlier as *version* in the Select Device Area of the Project Properties Dialog Box.

If you select *version 1.14* as the *version* in the Select Device Area of the Project Properties Dialog Box, you can use only the functions that are supported by project unit version 1.14. You cannot use functionality that was added for unit version 1.16 or later of the CPU Unit.



Additional Information

Project Unit Version for Projects

- With Sysmac Studio version 1.02 or higher, you can select the unit version in the Select Device Area of the relevant dialog boxes.
- You can select any unit version that is the same as or earlier than the unit version of the CPU Unit. For example, if the unit version of the CPU Unit is 1.14, select either *1.13* or *1.14*.
- The Sysmac Studio will treat the project unit version as the unit version of the CPU Unit. For example, if the project unit version is 1.13, you can use the functionality for unit version 1.13 on the Sysmac Studio.
- You can transfer a project to the Sysmac Studio if the project unit version is the same as or earlier than the unit version of the destination CPU Unit.
- Refer to the *Sysmac Studio Version 1 Operation Manual (Cat. No. W504-E1-03 or later)* for details on the Select Device Area of the relevant dialog boxes.

A-3-2 Functions That Were Added or Changed for Each Unit Version

This section describes the functions that were added or changed for each unit version of NX-series NX1P2 CPU Unit.

● Additions and Changes to Functional Specifications

The following table gives the unit version of the CPU Units and the Sysmac Studio version for each addition or change to the functional specifications.

Function				Addition/ change	Unit ver- sion	Sys- mac Studio version	Reference
Motion control	Single axes	Auxiliary function for single-axis control	Cam monitor	Addition	Ver.1.21	Ver.1.28	<i>NJ/NX-series CPU Unit Motion Control User's Manual (Cat. No. W507)</i>
Communications	Built-in EtherCAT port	Packet monitoring		Change*1	Ver.1.40	Ver.1.29	<i>NJ/NX-series CPU Unit Built-in EtherCAT Port User's Manual (Cat. No. W505)</i>
		Topology	Ring	Addition	Ver.1.40	Ver.1.29	

*1. Packet monitoring can be used with project unit version earlier than 1.40. It cannot be used with project unit version 1.40 or later.

Note Refer to the manuals for the function modules for additions and changes to function module functions for each unit version of the CPU Units.

● Additions and Changes to Basic Instructions and Motion Control Instructions

The basic instructions and motion control instructions that you can use have increased or changed for the new unit version of the CPU Unit.

For details, refer to the *NJ/NX-series Instructions Reference Manual (Cat. No. W502)* and *NJ/NX-series Motion Control Instructions Reference Manual (Cat. No. W508)*.

● Additions and Changes to Controller Events

The events that can occur have increased or changed for the new unit version of the CPU Unit. There are also changes in the recovery methods to use when some errors occur.

For details, refer to the *NJ/NX-series Troubleshooting Manual (Cat. No. W503)*.

● Additions and Changes to System-defined Variables

The system-defined variables that you can use have increased or changed for the new unit version of the CPU Unit.

Refer to the *NJ/NX-series CPU Unit Software User's Manual (Cat. No. W501)* for details.

A-4 Support Functions of the CPU Units and Restrictions on the NX Units

Some support functions of the CPU Unit are restricted depending on the models and unit versions of NX Units mounted on it.

The table below shows the functions that are restricted depending on the models and unit versions of the NX Units.

Refer to the *NX-series Data Reference Manual* (Cat. No. W525-E1-11 or later) for details on supported models and unit versions of NX Units.

Function	
Restarting	Restarting a specified NX Unit
Monitoring total power-ON time	
Restarting after transferring Unit operation settings	Restarting the NX Unit to which the Unit operation settings were transferred when you transfer the settings to a specified NX Unit

Refer to the *NX-series Data Reference Manual* (Cat. No. W525-E1-11 or later) for information on NX Units that can be connected to the NX-series NX1P2 CPU Unit.



Index

Index

- A**
- Additional I/O Power Supply Unit..... 4-5
 - Additional NX Unit Power Supply Unit..... 4-4
 - Analog I/O Option Board..... 3-29
 - Analog Input Option Board..... 3-27
 - Analog Output Option Board..... 3-28
 - Applicable standards..... A-2
 - applicable wires..... 5-49
 - attaching a terminal block..... 5-61
- B**
- Basic System Configuration..... 1-6, 2-2
 - Battery..... A-2
 - Battery connector..... 3-6
 - Battery cover..... 3-6
 - Battery Installation Procedure..... 5-33
 - Battery Replacement Procedure..... 7-6
 - Battery Service Life and Replacement Period..... 7-7
 - Battery slot..... 3-6
 - Battery-related Error Detection Setting..... 3-19
 - Block..... 4-20
 - Built-in EtherCAT port..... 2-3, 3-6
 - built-in EtherNet/IP port..... 1-7
 - Built-in EtherNet/IP port..... 3-6
 - Built-in I/O..... 3-2
 - BUSY..... 3-8
- C**
- Calculating the Effective Value..... 4-18
 - Cleaning..... 7-2
 - commercially available markers..... 5-26
 - Communications Cable..... 2-5
 - Configuration Units..... 2-5
 - connecting/removing wires..... 5-53
 - CPU Rack..... 2-4
 - CPU Unit..... 3-2
 - crimping tool..... 5-51
- D**
- D-sub Connector..... 5-70
 - Daisy chain..... 5-88, 5-90
 - DIN Track..... 5-16, 5-19
 - DIN Track contact plate..... 3-6, 5-45
 - DIN Track Insulation Spacer..... 5-48
 - DIN Track mounting hook..... 3-5
 - DIP switch..... 3-5
- E**
- Earthing Methods..... 5-88
 - Electrical Specifications..... 3-3
 - End Cover..... 2-5, 3-6, 5-24
 - End Plate..... 5-16, 5-17, 5-25
 - Equipotential bonding system..... 5-88, 5-89
 - ERROR..... 3-8
 - EtherCAT Network Configuration..... 1-6, 2-3
 - Event log..... 5-7
- F**
- Fail-safe Circuits..... 5-8
 - ferrules..... 5-51
 - Functional Grounding..... 5-45, 5-92
- G**
- Grounding..... 5-44, 5-88
- H**
- Hole for securing wires..... 3-12
- I**
- I/O power supply..... 4-3, 4-21
 - I/O Power Supply Connection Unit..... 4-6
 - ID information indication..... 3-6
 - ID Information Indication..... 3-20
 - Input indicator..... 3-6
 - Input Specifications..... 3-14
 - Input terminal block..... 3-6, 3-13
 - inrush current..... 4-21, 5-66
 - Installation Dimensions..... 5-38
 - Installation Height..... 5-41
 - Installation in Cabinets or Control Panels..... 5-12
 - Installation Locations for Protective Devices..... 4-23
 - Installation Method in Control Panels..... 5-14
 - Interlock Circuits..... 5-9
- L**
- LINK/ACT..... 3-10
 - lock levers..... 5-32
 - Lot number..... 3-20
- M**
- MAC addresses..... 3-20
 - Maximum I/O Power Supply Current..... 4-12
 - Mechanical Specifications..... 3-3
 - Momentary Power Interruption..... 5-7
- N**
- NET ERR..... 3-10
 - NET RUN..... 3-10
 - Network Configuration..... 1-7, 2-8
 - NX bus connector..... 3-6

- NX Unit..... 2-5, 3-32
 NX Unit Power Supply Capacity..... 4-8
- ## O
- Operating environment..... A-2
 Operating Mode at Startup..... 5-4
 Operating Procedure..... 1-14
 Operation until Operation Ready Status..... 5-3
 Option Board..... 2-5
 Option board slot..... 3-6
 order of powering off..... 5-9
 order of powering on..... 5-9
 Output indicator..... 3-6
 Output Short-circuit Protection..... 5-65
 Output Specifications..... 3-17
 Output terminal block..... 3-6, 3-15
 Overcurrent..... 4-22
- ## P
- Periodic Inspection Items..... 7-3
 POWER..... 3-7
 Power OFF Operation..... 5-5
 Power Supply-related Unit..... 3-31, 4-4
 preventing incorrect attachment of terminal blocks..... 5-62
 Protective device..... 4-22
- ## R
- Recommended Power Supplies..... 4-19, 4-21
 Recommended screwdriver 5-53, 5-72, 5-77
 Release hole..... 3-12
 removing a terminal block..... 5-60
 replacement battery..... 7-6
 Required Power Supply Capacity of the I/O Power Supply....
 4-21
 Required Power Supply Capacity of the Unit Power Supply..
 4-19
 restricted region..... 5-18
 Restrictions on Inrush Current..... 4-18
 RS-232C Option Board..... 3-23
 RS-422A/485 Option Board..... 3-24
 RUN..... 3-8
- ## S
- Safe Mode..... 3-6
 Screw for securing..... 3-12
 SD BUSY..... 3-8
 SD Memory Card..... 2-5, 5-27
 SD Memory Card connector..... 3-5
 SD Memory Card cover..... 3-6
 SD Memory Card power supply switch..... 3-5
 SD PWR..... 3-8
 Securing Wires..... 5-55
 Selecting Protective Device..... 4-22
 solid wires..... 5-54
 special marker printer..... 5-26
 Star earthing..... 5-88, 5-89
- Startup..... 3-8
 Supply from external source..... 4-10
 supply from the NX bus..... 4-10
 Support Software..... 1-6, 1-8
 Sysmac Studio..... 3-33
- ## T
- Terminal hole..... 3-12
 The voltage drop in the I/O power supply..... 4-11, 4-15
 twisted wires..... 5-54
- ## U
- Unit hookup guide..... 3-6
 Unit power supply..... 4-3, 4-19
 Unit Version..... 3-20, A-6
- ## W
- Wiring Ducts..... 5-14
 Wiring the Unit Power Supply..... 5-43
 Write Protection Key..... 3-21

OMRON Corporation Industrial Automation Company
Kyoto, JAPAN

Contact: www.ia.omron.com

Regional Headquarters

OMRON EUROPE B.V.

Wegalaan 67-69, 2132 JD Hoofddorp
The Netherlands
Tel: (31)2356-81-300/Fax: (31)2356-81-388

OMRON ELECTRONICS LLC

2895 Greenspoint Parkway, Suite 200
Hoffman Estates, IL 60169 U.S.A.
Tel: (1) 847-843-7900/Fax: (1) 847-843-7787

OMRON ASIA PACIFIC PTE. LTD.

No. 438A Alexandra Road # 05-05/08 (Lobby 2),
Alexandra Technopark,
Singapore 119967
Tel: (65) 6835-3011/Fax: (65) 6835-2711

OMRON (CHINA) CO., LTD.

Room 2211, Bank of China Tower,
200 Yin Cheng Zhong Road,
PuDong New Area, Shanghai, 200120, China
Tel: (86) 21-5037-2222/Fax: (86) 21-5037-2200

Authorized Distributor:

© OMRON Corporation 2016-2019 All Rights Reserved.
In the interest of product improvement,
specifications are subject to change without notice.

Cat. No. W578-E1-07

1019