



**Auxiliary contact module, Type: Front mounting auxiliary contact, 2 pole, I<sub>th</sub>= 16 A, 2 NC, Front fixing, Screw terminals**



**Part no. DILM32-XHI02**  
**Catalog No. 277375**  
**Alternate Catalog No. XTCEXFCC02**  
**EL-Nummer (Norway) 4130433**

**Delivery program**

Accessories				Auxiliary contact modules
Description				with interlocked opposing contacts
Function				for standard applications
Number of poles				2 pole
Connection technique				Screw terminals
<b>Rated operational current</b>				
Conventional free air thermal current, 1 pole				
Open				
at 60 °C	I <sub>th</sub>	A		16
AC-15				
220 V 230 V 240 V	I <sub>e</sub>	A		4
380 V 400 V 415 V	I <sub>e</sub>	A		4
<b>Contacts</b>				
N/C = Normally closed				2 NC
Mounting type				Front fixing
Contact sequence				
For use with				DILM(C)7-10... DILM(C)9-10... DILM(C)12-10... DILM(C)15-10... DILM(C)17-10... DILM(C)25-10... DILM(C)32-10... DILM38-10... DILMP20... DILMP32-10... DILMP45-10... DILL... DILMF8-10... DILMF11-10... DILMF14-10... DILMF17-10... DILMF25-10... DILMF32-10...
Type				Front mounting auxiliary contact
Instructions				Interlocked opposing contacts according to IEC/EN 60947-5-1 appendix L, inside the auxiliary contact modules, also for the integrated auxiliary contacts of the DILM 7 - DILM32 Auxiliary contacts used as mirror contacts according to IEC/EN 60947-4-1 Appendix F (not N/C late open)

**Technical data**

<b>General</b>				
Standards				IEC/EN 60947, VDE 0660, UL, CSA
Component lifespan				
at U <sub>e</sub> = 230 V, AC-15, 3 A	Operations	x 10 <sup>6</sup>		1.3

Climatic proofing			Damp heat, constant, to IEC 60068-2-78 Damp heat, cyclic, to IEC 60068-2-30
Ambient temperature			
Open		°C	-25 - +60
Enclosed		°C	- 25 - 40
Ambient temperature, storage		°C	- 40 - 80
Mechanical shock resistance (IEC/EN 60068-2-27)			
Half-sinusoidal shock, 10 ms			
Basic unit with auxiliary contact module		g	
N/O contact		g	7
N/C contact		g	5
Degree of Protection			IP20
Protection against direct contact when actuated from front (EN 50274)			Finger and back-of-hand proof
Weight		kg	0.038
Terminal capacities		mm <sup>2</sup>	
Screw terminals			
Solid		mm <sup>2</sup>	1 x (0.75 - 2.5) 2 x (0.75 - 2.5)
Flexible with ferrule		mm <sup>2</sup>	1 x (0.75 - 2.5) 2 x (0.75 - 2.5)
Solid or stranded		AWG	18 – 14
Pozidriv screwdriver		Size	2
Standard screwdriver		mm	0.8 x 5.5 1 x 6
Max. tightening torque		Nm	1.2

## Contacts

Interlocked opposing contacts within an auxiliary contact module (to IEC 60947-5-1 Annex L)				Yes
N/C contact (not late-break contact) suitable as a mirror contact (to IEC/EN 60947-4-1 Annex F)				DILM7 - DILM38
Rated impulse withstand voltage	$U_{imp}$	V AC		6000
Overvoltage category/pollution degree				III/3
Rated insulation voltage	$U_i$	V AC		690
Rated operational voltage	$U_e$	V AC		500
Safe isolation to EN 61140				
between coil and auxiliary contacts		V AC		400
between the auxiliary contacts		V AC		400
Rated operational current		A		
Conventional free air thermal current, 1 pole				
at 60 °C	$I_{th}$	A		16
AC-15				
220 V 230 V 240 V	$I_e$	A		4
380 V 400 V 415 V	$I_e$	A		4
500 V	$I_e$	A		1.5
DC current				
				Switch-on and switch-off conditions based on DC-13, time constant as specified.
DC L/R $\leq$ 15 ms				
Contacts in series:		A		
1	24 V	A		10
1	60 V	A		6
1	110 V	A		3
1	220 V	A		1
DC-13 (6xP)				
24 V	$I_e$	A		2.5
60 V	$I_e$	A		1
110 V	$I_e$	A		0.5
220 V	$I_e$	A		0.25

Control circuit reliability	Failure rate $\lambda$		$<10^{-8}$ , < one failure at 100 million operations (at $U_e = 24$ V DC, $U_{min} = 17$ V, $I_{min} = 5.4$ mA)
Short-circuit rating without welding			
Short-circuit protection maximum fuse			
500 V	A gG/gL	10	
Current heat loss at $I_{th}$			
AC operated	W	2.6	
DC operated	W	2.6	
Current heat loss per auxiliary circuit at $I_e$ (AC-15/230 V)	CO	0.16	

**Rating data for approved types**

Auxiliary contacts			
Pilot Duty			
AC operated			A600
DC operated			P300
General Use			
AC	V	600	
AC	A	10	
DC	V	250	
DC	A	1	

**Design verification as per IEC/EN 61439**

Technical data for design verification			
Rated operational current for specified heat dissipation	$I_n$	A	4
Heat dissipation per pole, current-dependent	$P_{vid}$	W	0.16
Equipment heat dissipation, current-dependent	$P_{vid}$	W	0
Static heat dissipation, non-current-dependent	$P_{vs}$	W	0
Heat dissipation capacity	$P_{diss}$	W	0
Operating ambient temperature min.		°C	-25
Operating ambient temperature max.		°C	60
IEC/EN 61439 design verification			
10.2 Strength of materials and parts			
10.2.2 Corrosion resistance			Meets the product standard's requirements.
10.2.3.1 Verification of thermal stability of enclosures			Meets the product standard's requirements.
10.2.3.2 Verification of resistance of insulating materials to normal heat			Meets the product standard's requirements.
10.2.3.3 Verification of resistance of insulating materials to abnormal heat and fire due to internal electric effects			Meets the product standard's requirements.
10.2.4 Resistance to ultra-violet (UV) radiation			Meets the product standard's requirements.
10.2.5 Lifting			Does not apply, since the entire switchgear needs to be evaluated.
10.2.6 Mechanical impact			Does not apply, since the entire switchgear needs to be evaluated.
10.2.7 Inscriptions			Meets the product standard's requirements.
10.3 Degree of protection of ASSEMBLIES			Does not apply, since the entire switchgear needs to be evaluated.
10.4 Clearances and creepage distances			Meets the product standard's requirements.
10.5 Protection against electric shock			Does not apply, since the entire switchgear needs to be evaluated.
10.6 Incorporation of switching devices and components			Does not apply, since the entire switchgear needs to be evaluated.
10.7 Internal electrical circuits and connections			Is the panel builder's responsibility.
10.8 Connections for external conductors			Is the panel builder's responsibility.
10.9 Insulation properties			
10.9.2 Power-frequency electric strength			Is the panel builder's responsibility.
10.9.3 Impulse withstand voltage			Is the panel builder's responsibility.
10.9.4 Testing of enclosures made of insulating material			Is the panel builder's responsibility.
10.10 Temperature rise			The panel builder is responsible for the temperature rise calculation. Eaton will provide heat dissipation data for the devices.
10.11 Short-circuit rating			Is the panel builder's responsibility. The specifications for the switchgear must be observed.
10.12 Electromagnetic compatibility			Is the panel builder's responsibility. The specifications for the switchgear must be observed.

10.13 Mechanical function

The device meets the requirements, provided the information in the instruction leaflet (IL) is observed.

## Technical data ETIM 7.0

Low-voltage industrial components (EG000017) / Auxiliary contact block (EC000041)

Electric engineering, automation, process control engineering / Low-voltage switch technology / Component for low-voltage switching technology / Auxiliary switch block (ecI@ss10.0.1-27-37-13-02 [AKN342013])

Number of contacts as change-over contact		0
Number of contacts as normally open contact		0
Number of contacts as normally closed contact		2
Number of fault-signal switches		0
Rated operation current I <sub>e</sub> at AC-15, 230 V	A	6
Type of electric connection		Screw connection
Model		Top mounting
Mounting method		Front fastening
Lamp holder		None

## Approvals

Product Standards		IEC/EN 60947-4-1; UL 508; CSA-C22.2 No. 14-05; CE marking
UL File No.		E29184
UL Category Control No.		NKCR
CSA File No.		012528
CSA Class No.		3211-03
North America Certification		UL listed, CSA certified
Specially designed for North America		No

## Dimensions

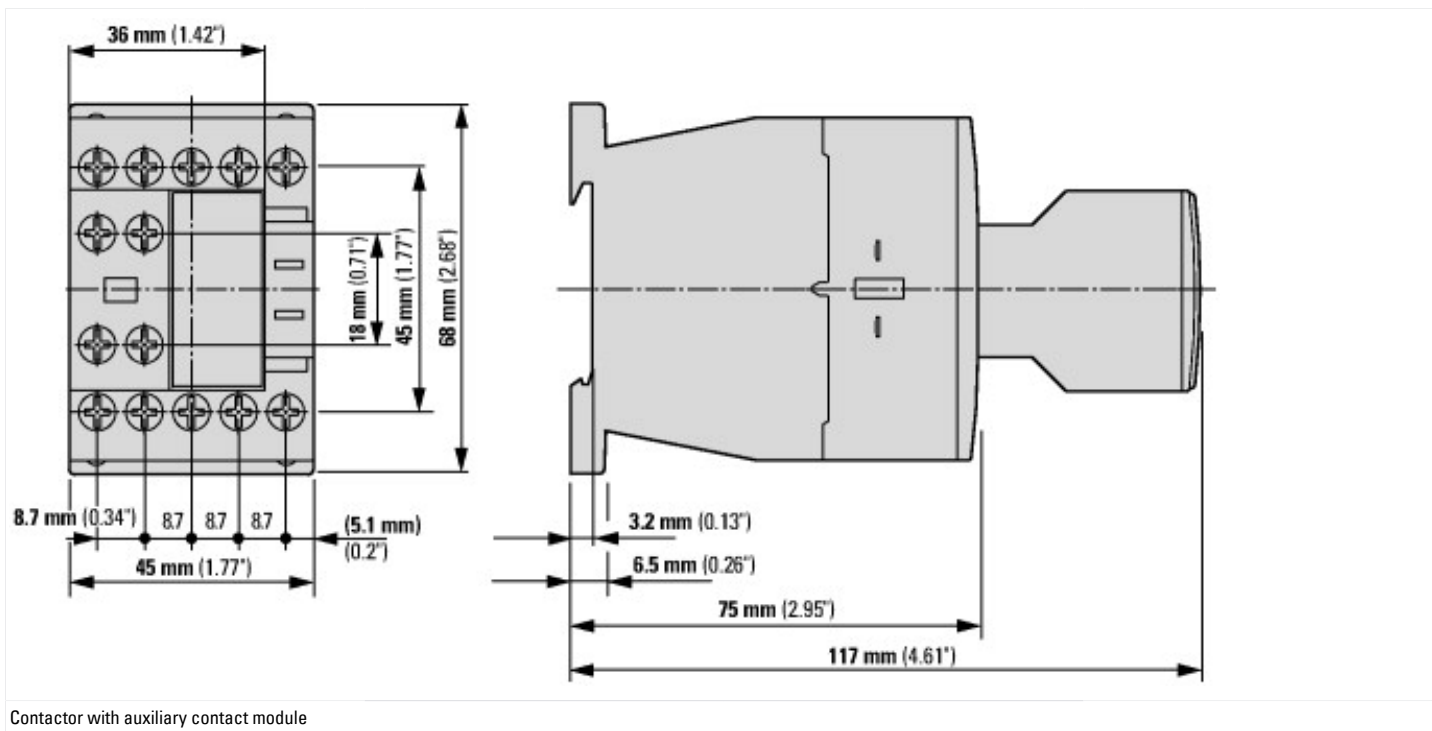

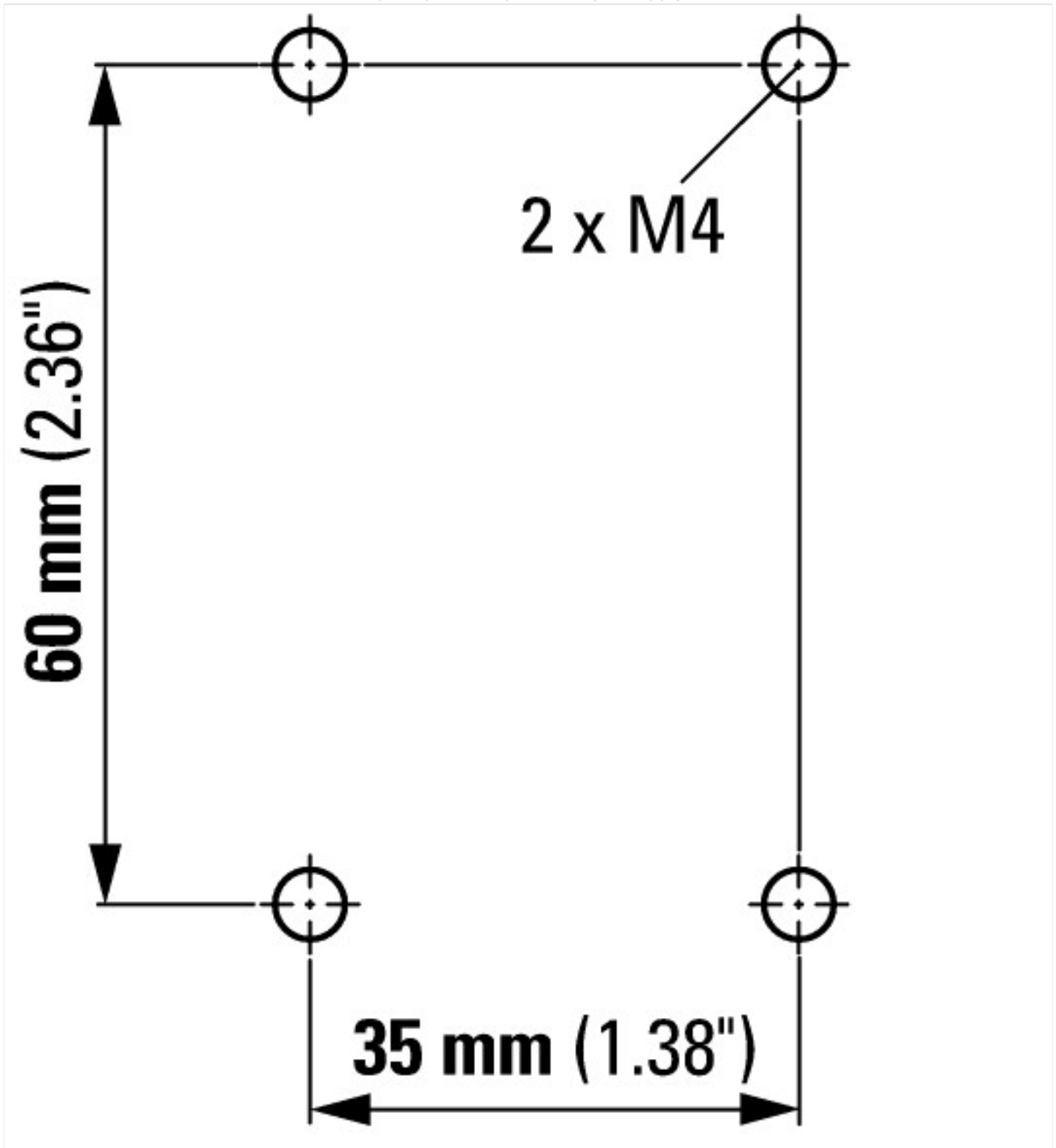



# SCATTERGOOD & JOHNSON LTD

ELECTRICAL ENGINEERING & FLUID CONTROL DISTRIBUTORS

Est.1899

At Scattergood & Johnson Ltd, we pride ourselves on being a technical distributor to specialist industries.

Working with a range of quality product suppliers across a number of specialist markets, we are not your average 'box shifter' - we are your technical and supply chain partner.

We fully support every product we sell - for free! Our internal team and external sales engineers can answer any product or application question, no matter the complexity.

Backing up this technical ability is a range of 50,000+ products available from stock for nationwide next day delivery (same day if required!), or you can collect what you need from any of our trade counters around the UK.

Select your specialist interest below to learn more about how we can help.



Online, In Branch and On the Road - Scattergood & Johnson Ltd, there when you need us.

# [www.scatts.co.uk](http://www.scatts.co.uk)