

**DATASHEET - DILM580/22(RA250)**



**Contactors, 380 V 400 V 315 kW, 2 N/O, 2 NC, RA 250: 110 - 250 V 40 - 60 Hz/110 - 350 V DC, AC and DC operation, Screw connection**



**Part no. DILM580/22(RA250)**  
**Catalog No. 208216**  
**Alternate Catalog No. XTCE580N22A**  
**EL-Nummer (Norway) 4134087**

**Delivery program**

Product range				Contactors
Application				Contactors for Motors
Subrange				Comfort devices greater than 170 A
Utilization category				AC-1: Non-inductive or slightly inductive loads, resistance furnaces NAC-3: Normal AC induction motors: starting, switch off during running AC-4: Normal AC induction motors: starting, plugging, reversing, inching
Connection technique				Screw connection
<b>Rated operational current</b>				
AC-3				
380 V 400 V	$I_e$	A		580
AC-1				
Conventional free air thermal current, 3 pole, 50 - 60 Hz				
Open				
at 40 °C	$I_{th} = I_e$	A		980
Conventional free air thermal current, 1 pole				
open	$I_{th}$	A		2000
<b>Max. rating for three-phase motors, 50 - 60 Hz</b>				
AC-3				
220 V 230 V	P	kW		185
380 V 400 V	P	kW		315
660 V 690 V	P	kW		560
1000 V	P	kW		600
AC-4				
220 V 230 V	P	kW		143
380 V 400 V	P	kW		250
660 V 690 V	P	kW		440
1000 V	P	kW		509
Contact sequence				
Can be combined with auxiliary contact				DILM820-XHI...
Actuating voltage				RA 250: 110 - 250 V 40 - 60 Hz/110 - 350 V DC
Voltage AC/DC				AC and DC operation
<b>Contacts</b>				
N/O = Normally open				2 N/O
N/C = Normally closed				2 NC
<b>Auxiliary contacts</b>				
possible variants at auxiliary contact module fitting options				on the side: 2 x DILM820-XHI11(V)-SI; 2 x DILM820-XHI11-SA
Side mounting auxiliary contacts				
<b>Instructions</b>				Interlocked opposing contacts according to IEC/EN 60947-5-1 Appendix L, inside the auxiliary contact module Auxiliary contacts used as mirror contacts according to IEC/EN 60947-4-1 Appendix F (not N/C late open)
<b>Instructions</b>				integrated suppressor circuit in actuating electronics

## Technical data

### General

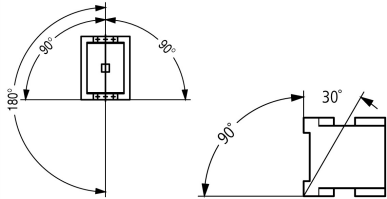
Standards			IEC/EN 60947, VDE 0660, UL, CSA
Lifespan, mechanical			
AC operated	Operations	$\times 10^6$	5
DC operated	Operations	$\times 10^6$	5
Operating frequency, mechanical			
AC operated	Operations/h		1000
DC operated	Operations/h		1000
Climatic proofing			Damp heat, constant, to IEC 60068-2-78 Damp heat, cyclic, to IEC 60068-2-30
Ambient temperature			
Open		°C	-40 - +60
Enclosed		°C	-40 - +40
Storage		°C	-40 - +80
Mounting position			
Mechanical shock resistance (IEC/EN 60068-2-27)			
Half-sinusoidal shock, 10 ms			
Main contacts			
N/O contact		g	10
Auxiliary contacts			
N/O contact		g	10
N/C contact		g	8
Degree of Protection			IP00
Protection against direct contact when actuated from front (EN 50274)			Finger and back-of-hand proof with terminal shroud or terminal block
Altitude		m	Max. 2000
Weight			
AC operated		kg	16.21
DC operated		kg	16.21
Weight		kg	16.21
Terminal capacity main cable			
Flexible with cable lug		mm <sup>2</sup>	50 - 240
Stranded with cable lug		mm <sup>2</sup>	70 - 240
Solid or stranded		AWG	2/0 - 500 MCM
Flat conductor	Lamellenzahl x Breite x Dicke	mm	Fixing with flat cable terminal or cable terminal blocks See terminal capacity for cable terminal blocks
Busbar	Width	mm	50
Main cable connection screw/bolt			M10
Tightening torque		Nm	24
Terminal capacity control circuit cables			
Solid		mm <sup>2</sup>	1 x (0.75 - 2.5) 2 x (0.75 - 2.5)
Flexible with ferrule		mm <sup>2</sup>	1 x (0.75 - 2.5) 2 x (0.75 - 2.5)
Solid or stranded		AWG	18 - 14
Control circuit cable connection screw/bolt			M3.5
Tightening torque		Nm	1.2
Tool			
Main cable			

Width across flats		mm	16
Control circuit cables			
Pozidriv screwdriver		Size	2

**Main conducting paths**

Rated impulse withstand voltage	$U_{imp}$	V AC	8000
Overvoltage category/pollution degree			III/3
Rated insulation voltage	$U_i$	V AC	1000
Rated operational voltage	$U_e$	V AC	1000
Safe isolation to EN 61140			
between coil and contacts		V AC	500
between the contacts		V AC	500
Making capacity (p.f. to IEC/EN 60947)		A	7800
Breaking capacity			
220 V 230 V		A	6500
380 V 400 V		A	6500
500 V		A	6500
660 V 690 V		A	6500
1000 V		A	4350
Component lifespan			AC1: See → Engineering, characteristic curves AC3: See → Engineering, characteristic curves AC4: See → Engineering, characteristic curves
Short-circuit rating			
Short-circuit protection maximum fuse			
Type "2" coordination			
400 V	gG/gL 500 V	A	630
690 V	gG/gL 690 V	A	630
1000 V	gG/gL 1000 V	A	500
Type "1" coordination			
400 V	gG/gL 500 V	A	1000
690 V	gG/gL 690 V	A	1000
1000 V	gG/gL 1000 V	A	630

**AC**

AC-1			
Rated operational current			
Conventional free air thermal current, 3 pole, 50 - 60 Hz			
Open			
at 40 °C	$I_{th} = I_e$	A	980
at 50 °C	$I_{th} = I_e$	A	876
at 55 °C	$I_{th} = I_e$	A	836
at 60 °C	$I_{th} = I_e$	A	800
Conventional free air thermal current, 1 pole			
Note			at maximum permissible ambient air temperature
open	$I_{th}$	A	2000
AC-3			
Rated operational current			
Open, 3-pole: 50 – 60 Hz			
Notes			At maximum permissible ambient temperature (open.)
220 V 230 V	$I_e$	A	580
240 V	$I_e$	A	580
380 V 400 V	$I_e$	A	580
415 V	$I_e$	A	580
440V	$I_e$	A	580
500 V	$I_e$	A	580
660 V 690 V	$I_e$	A	580

1000 V	I <sub>e</sub>	A	435
Motor rating	P	kWh	
220 V 230 V	P	kW	185
240V	P	kW	200
380 V 400 V	P	kW	315
415 V	P	kW	348
440 V	P	kW	370
500 V	P	kW	420
660 V 690 V	P	kW	560
1000 V	P	kW	600
<b>AC-4</b>			
Rated operational current			
Open, 3-pole: 50 – 60 Hz			
220 V 230 V	I <sub>e</sub>	A	456
240 V	I <sub>e</sub>	A	456
380 V 400 V	I <sub>e</sub>	A	456
415 V	I <sub>e</sub>	A	456
440 V	I <sub>e</sub>	A	456
500 V	I <sub>e</sub>	A	456
660 V 690 V	I <sub>e</sub>	A	456
1000 V	I <sub>e</sub>	A	348
Motor rating	P	kWh	
220 V 230 V	P	kW	143
240 V	P	kW	156
380 V 400 V	P	kW	250
415 V	P	kW	274
440 V	P	kW	290
500 V	P	kW	330
660 V 690 V	P	kW	440
1000 V	P	kW	509

### Condensator operation

Individual compensation, rated operational current I <sub>e</sub> of three-phase capacitors			
Open			
up to 525 V		A	463
690 V		A	265
Max. inrush current peak		x I <sub>e</sub>	30
Component lifespan	Operations	x 10 <sup>6</sup>	0.1
Max. operating frequency		Ops/h	200

### Current heat loss

3 pole, at I <sub>th</sub> (60°)		W	61
Current heat loss at I <sub>e</sub> to AC-3/400 V		W	32

### Magnet systems

Voltage tolerance			
U <sub>S</sub>			110 - 250 V 40-60 Hz 110 - 350 V DC
AC operated	Pick-up		0.7 x U <sub>S min</sub> - 1.15 x U <sub>S max</sub>
DC operated	Pick-up		0.7 x U <sub>S min</sub> - 1.15 x U <sub>S max</sub>
AC operated	Drop-out		0.2 x U <sub>S max</sub> - 0.6 x U <sub>S min</sub>
DC operated	Drop-out		0.2 x U <sub>S max</sub> - 0.6 x U <sub>S min</sub>
Power consumption of the coil in a cold state and 1.0 x U <sub>S</sub>			
Note on power consumption			Control transformer with u <sub>k</sub> ≤ 7%
Pull-in power	Pick-up	VA	800
Pull-in power	Pick-up	W	700
Sealing power	Sealing	VA	26.5
Sealing power	Sealing	W	11.4

Duty factor		% DF	100
Changeover time at 100 % U <sub>S</sub> (recommended value)			
Main contacts			
Closing delay		ms	70
Opening delay		ms	110
Behaviour in marginal and transitional conditions			
Sealing			
Voltage interruptions			
(0 ... 0.2 x U <sub>C min</sub> ) ≤ 10 ms			Time is bridged successfully
(0 ... 0.2 x U <sub>C min</sub> ) > 10 ms			Drop-out of the contactor
Voltage drops			
(0.2 ... 0.6 x U <sub>C min</sub> ) ≤ 12 ms			Time is bridged successfully
(0.2 ... 0.6 x U <sub>C min</sub> ) > 12 ms			Drop-out of the contactor
(0.6 ... 0.7 x U <sub>C min</sub> )			Contactor remains switched on
Excess voltage			
(1.15 ... 1.3 x U <sub>C max</sub> )			Contactor remains switched on
Pick-up phase			
(0 ... 0.7 x U <sub>C min</sub> )			Contactor does not switch on
(0.7 x U <sub>C min</sub> ... 1.15 x U <sub>C max</sub> )			Contactor switches on with certainty
Admissible transitional contact resistance (of the external control circuit device when actuating A11)		mΩ	≤ 500
PLC signal level (A3 - A4) to IEC/EN 61131-2 (type 2)			
High		V	15
Low		V	5

### Electromagnetic compatibility (EMC)

Electromagnetic compatibility			This product is designed for operation in industrial environments (environment A). Its use in residential environments (environment B) may cause radio-frequency interference, requiring additional noise suppression measures.
-------------------------------	--	--	---

### Rating data for approved types

Switching capacity			
Maximum motor rating			
Three-phase			
200 V 208 V		HP	200
230 V 240 V		HP	200
460 V 480 V		HP	400
575 V 600 V		HP	600
General use		A	980
Auxiliary contacts			
Pilot Duty			
AC operated			A600
DC operated			P300
General Use			
AC		V	600
AC		A	15
DC		V	250
DC		A	1
Short Circuit Current Rating		SCCR	
Basic Rating			
SCCR		kA	30
max. Fuse		A	2000
max. CB		A	1200
480 V High Fault			
SCCR (fuse)		kA	85
max. Fuse		A	2000

SCCR (CB)	kA	85
max. CB	A	1200
600 V High Fault		
SCCR (fuse)	kA	85
max. Fuse	A	2000
SCCR (CB)	kA	85
max. CB	A	1200
Special Purpose Ratings		
Definite Purpose Ratings (100,000 cycles acc. to UL 1995)		
LRA 480V 60Hz 3phase	A	4020
FLA 480V 60Hz 3phase	A	670
LRA 600V 60Hz 3phase	A	4020
FLA 600V 60Hz 3phase	A	670

## Design verification as per IEC/EN 61439

Technical data for design verification			
Rated operational current for specified heat dissipation	$I_n$	A	580
Heat dissipation per pole, current-dependent	$P_{vid}$	W	10.67
Equipment heat dissipation, current-dependent	$P_{vid}$	W	0
Static heat dissipation, non-current-dependent	$P_{vs}$	W	6.5
Heat dissipation capacity	$P_{diss}$	W	0
Operating ambient temperature min.		°C	-40
Operating ambient temperature max.		°C	60
IEC/EN 61439 design verification			
10.2 Strength of materials and parts			
10.2.2 Corrosion resistance			Meets the product standard's requirements.
10.2.3.1 Verification of thermal stability of enclosures			Meets the product standard's requirements.
10.2.3.2 Verification of resistance of insulating materials to normal heat			Meets the product standard's requirements.
10.2.3.3 Verification of resistance of insulating materials to abnormal heat and fire due to internal electric effects			Meets the product standard's requirements.
10.2.4 Resistance to ultra-violet (UV) radiation			Meets the product standard's requirements.
10.2.5 Lifting			Does not apply, since the entire switchgear needs to be evaluated.
10.2.6 Mechanical impact			Does not apply, since the entire switchgear needs to be evaluated.
10.2.7 Inscriptions			Meets the product standard's requirements.
10.3 Degree of protection of ASSEMBLIES			Does not apply, since the entire switchgear needs to be evaluated.
10.4 Clearances and creepage distances			Meets the product standard's requirements.
10.5 Protection against electric shock			Does not apply, since the entire switchgear needs to be evaluated.
10.6 Incorporation of switching devices and components			Does not apply, since the entire switchgear needs to be evaluated.
10.7 Internal electrical circuits and connections			Is the panel builder's responsibility.
10.8 Connections for external conductors			Is the panel builder's responsibility.
10.9 Insulation properties			
10.9.2 Power-frequency electric strength			Is the panel builder's responsibility.
10.9.3 Impulse withstand voltage			Is the panel builder's responsibility.
10.9.4 Testing of enclosures made of insulating material			Is the panel builder's responsibility.
10.10 Temperature rise			The panel builder is responsible for the temperature rise calculation. Eaton will provide heat dissipation data for the devices.
10.11 Short-circuit rating			Is the panel builder's responsibility. The specifications for the switchgear must be observed.
10.12 Electromagnetic compatibility			Is the panel builder's responsibility. The specifications for the switchgear must be observed.
10.13 Mechanical function			The device meets the requirements, provided the information in the instruction leaflet (IL) is observed.

## Technical data ETIM 7.0

Low-voltage industrial components (EG000017) / Power contactor, AC switching (EC000066)		
Electric engineering, automation, process control engineering / Low-voltage switch technology / Contactor (LV) / Power contactor, AC switching (ecl@ss10.0.1-27-37-10-03 [AAB718015])		
Rated control supply voltage $U_s$ at AC 50HZ	V	110 - 250

Rated control supply voltage Us at AC 60HZ	V	110 - 250
Rated control supply voltage Us at DC	V	110 - 250
Voltage type for actuating		AC/DC
Rated operation current Ie at AC-1, 400 V	A	980
Rated operation current Ie at AC-3, 400 V	A	580
Rated operation power at AC-3, 400 V	kW	315
Rated operation current Ie at AC-4, 400 V	A	456
Rated operation power at AC-4, 400 V	kW	250
Rated operation power NEMA	kW	298
Modular version		No
Number of auxiliary contacts as normally open contact		2
Number of auxiliary contacts as normally closed contact		2
Type of electrical connection of main circuit		Rail connection
Number of normally closed contacts as main contact		0
Number of main contacts as normally open contact		3

## Approvals

Product Standards		IEC/EN 60947-4-1; UL 60947-4-1; CSA - C22.2 No. 60947-4-1-14; CE marking
UL File No.		E29096
UL Category Control No.		NLDX
CSA File No.		012528
CSA Class No.		3211-04
North America Certification		UL listed, CSA certified
Specially designed for North America		No

## Characteristics

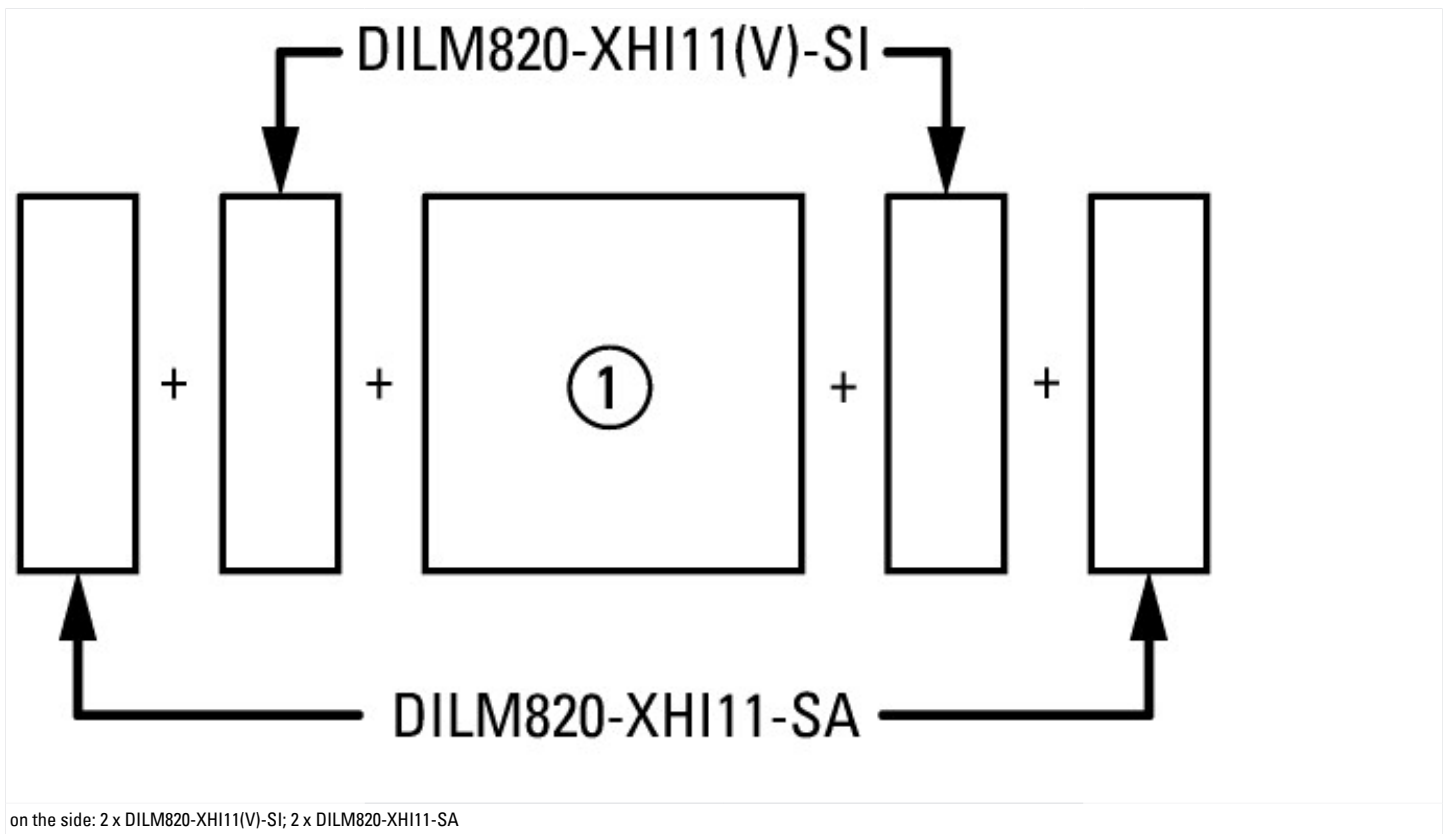

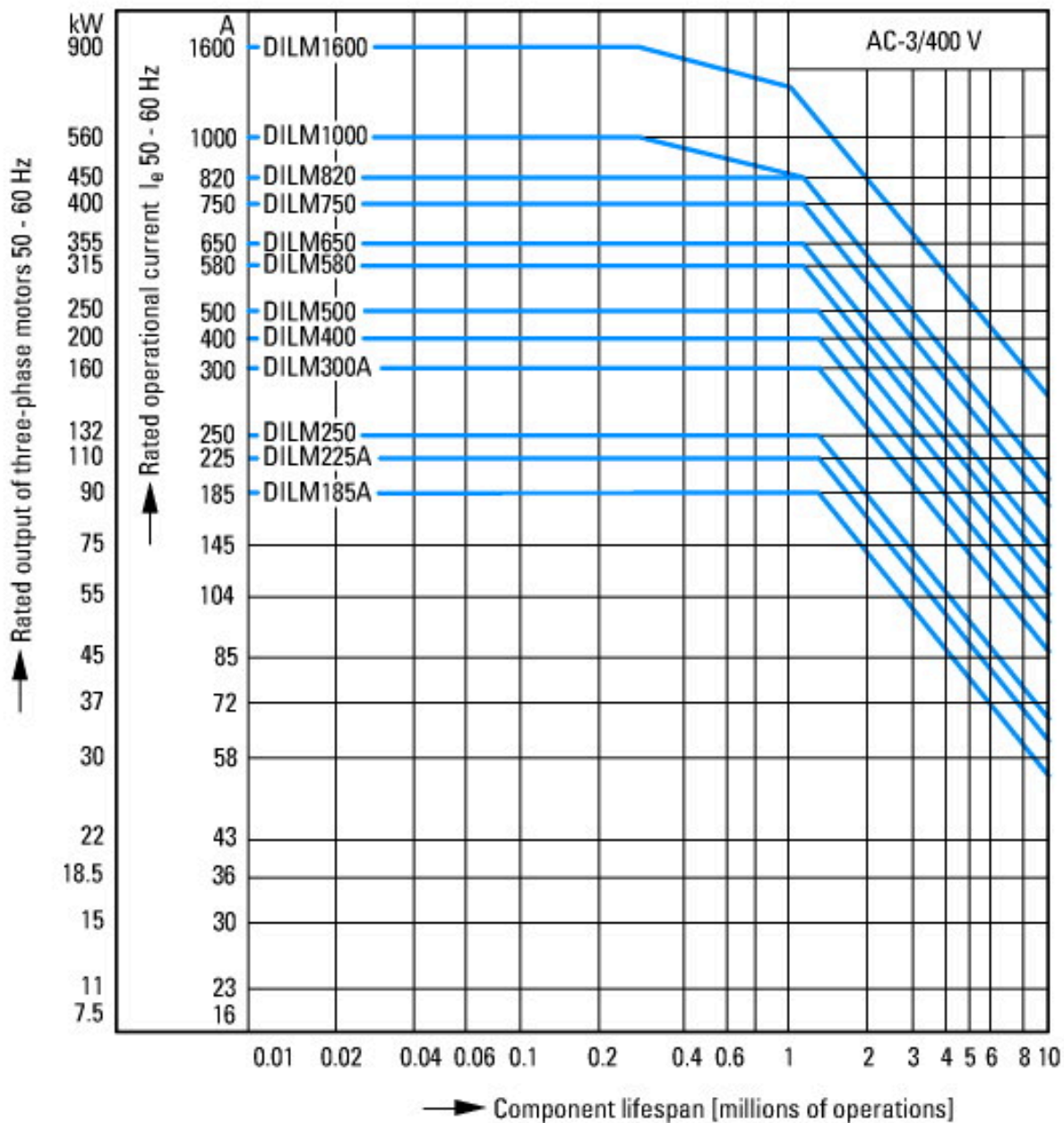

Normal switching duty  
 Normal AC induction motor  
 Operating characteristics  
 Switch on: from stop  
 Switch off: during run  
 Electrical characteristics:  
 Switch on: up to 6 x Rated motor current  
 Switch off: up to 1 x Rated motor current  
 Utility category  
 100 % AC-3  
 Typical Applications  
 Compressors  
 Lifts  
 Mixers  
 Pumps  
 Escalators  
 Agitators  
 fan  
 Conveyor belts  
 Centrifuges  
 Hinged flaps  
 Bucket-elevator  
 Air-conditioning systems  
 General drives for manufacturing and processing machines

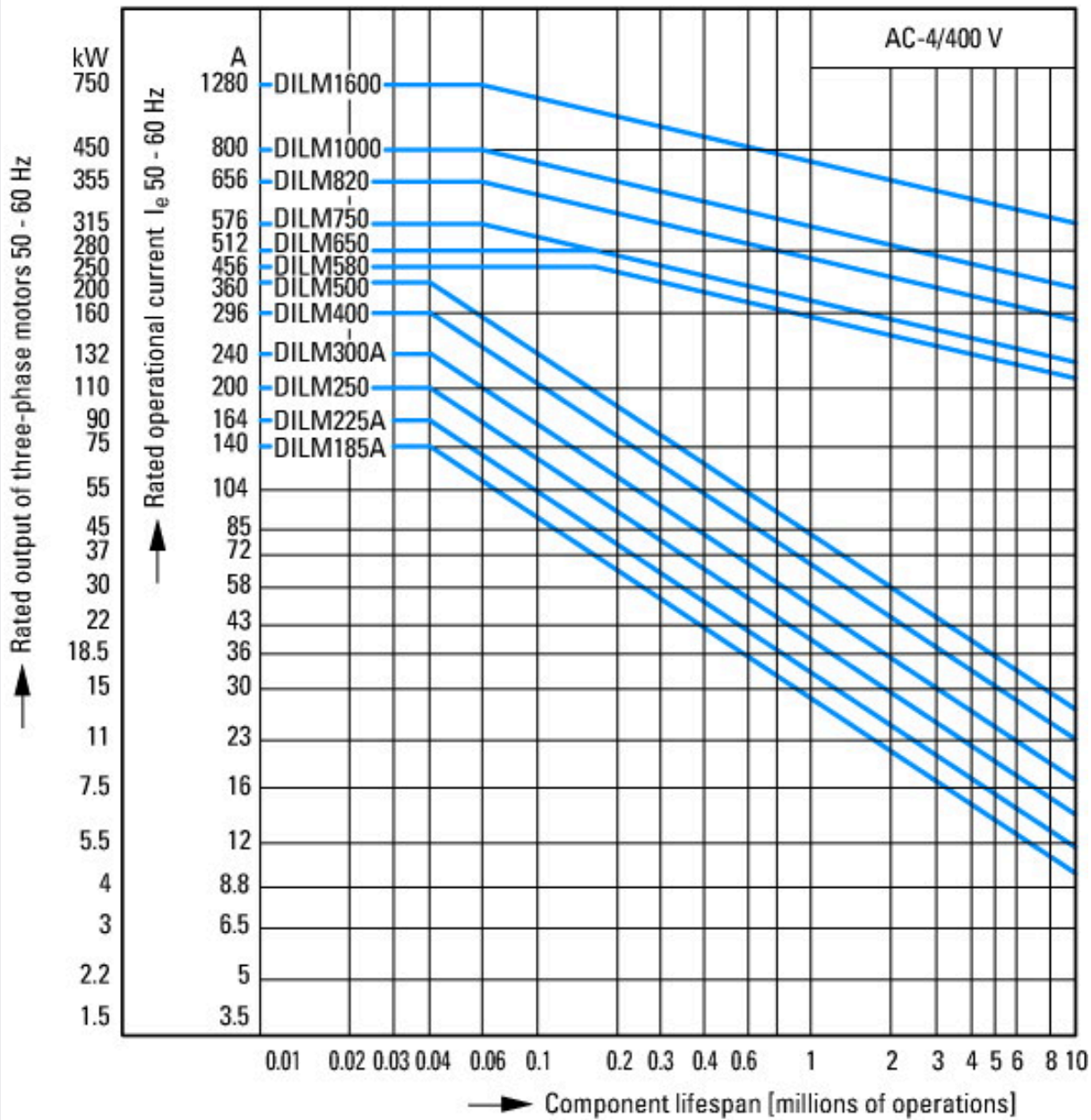

Extreme switching duty  
 Squirrel-cage motor  
 Operating characteristics  
 Inching, plugging, reversing  
 Electrical characteristics  
 Make: up to 6 x rated motor current  
 Break: up to 6 x rated motor current  
 Utilization category  
 100 % AC-4  
 Typical applications  
 Printing presses  
 Wire-drawing machines  
 Centrifuges  
 Special drives for manufacturing and processing machines



Switching conditions for 3 pole, non-motor loads  
 Operating characteristics  
 Non inductive and slightly inductive loads  
 Electrical characteristics  
 Switch on: 1 x rated operational current  
 Switch off: 1 x rated operational current  
 Utilization category  
 100 % AC-1  
 Typical examples of application  
 Electric heat

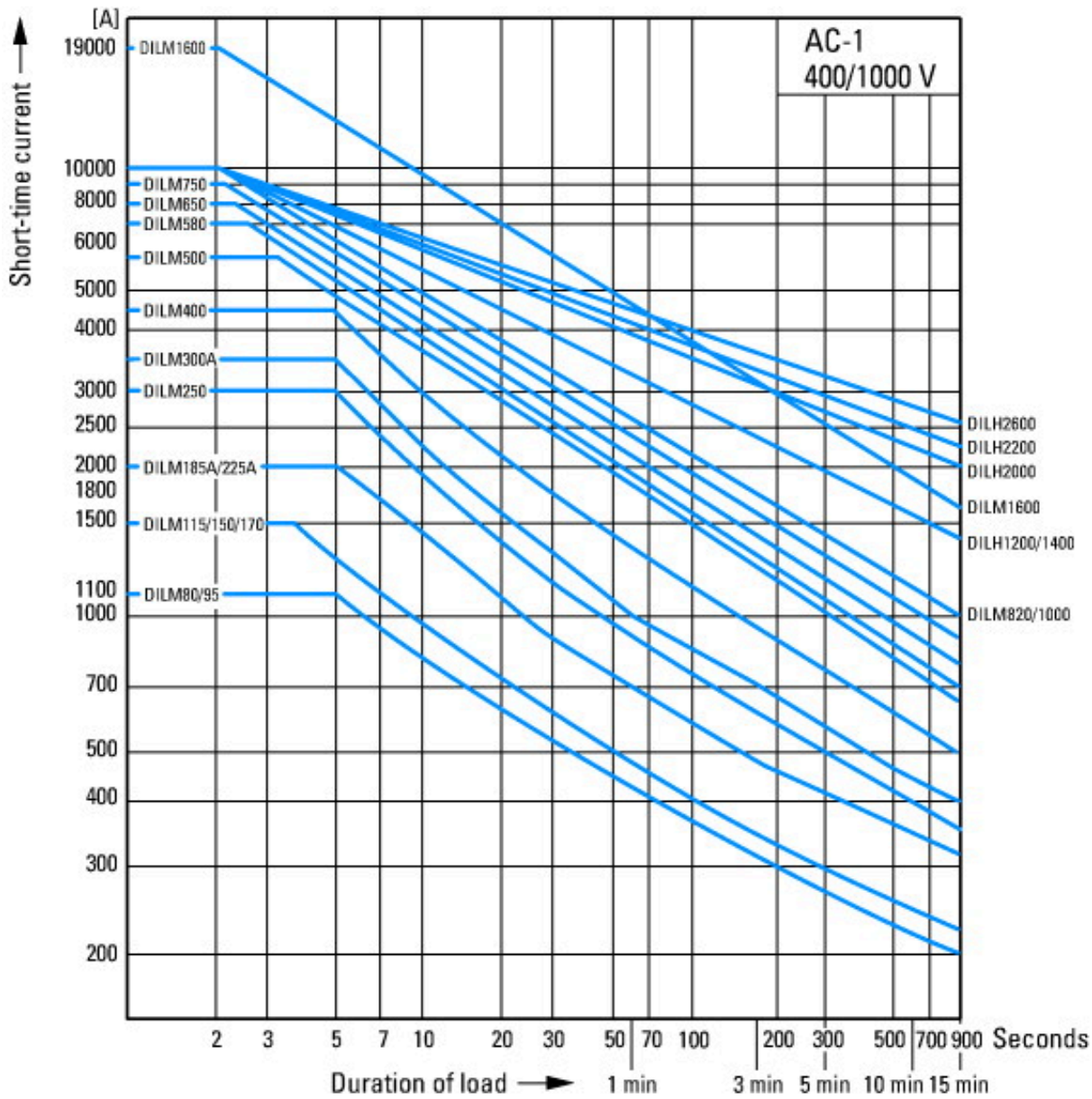

Short-time loading, 3-pole  
Time interval between two loading cycles: 15 minutes

### Dimensions

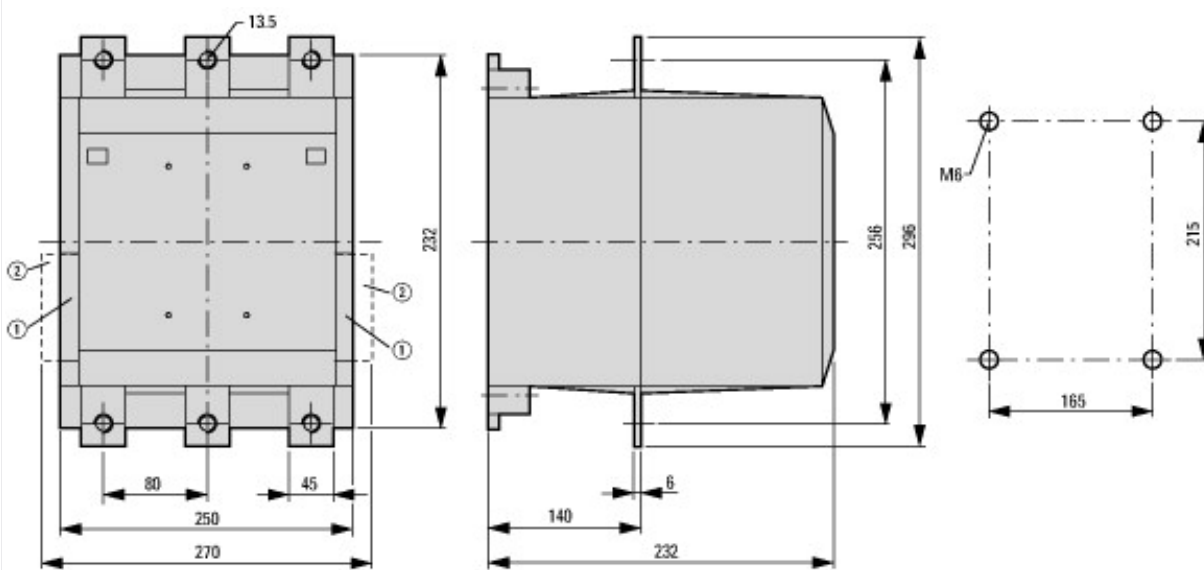

- ① DILM820-XHI11(V)-SI
- ② DILM820-XHI11-SA
- DILM580...DILM1000





# SCATTERGOOD & JOHNSON LTD

ELECTRICAL ENGINEERING & FLUID CONTROL DISTRIBUTORS

Est.1899

At Scattergood & Johnson Ltd, we pride ourselves on being a technical distributor to specialist industries.

Working with a range of quality product suppliers across a number of specialist markets, we are not your average 'box shifter' - we are your technical and supply chain partner.

We fully support every product we sell - for free! Our internal team and external sales engineers can answer any product or application question, no matter the complexity.

Backing up this technical ability is a range of 50,000+ products available from stock for nationwide next day delivery (same day if required!), or you can collect what you need from any of our trade counters around the UK.

Select your specialist interest below to learn more about how we can help.



Online, In Branch and On the Road - Scattergood & Johnson Ltd, there when you need us.

# [www.scatts.co.uk](http://www.scatts.co.uk)