

DATASHEET - NZM1-XSRM-L

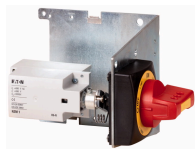

Main switch assembly kit, on the left side, red, size 1



Part no. NZM1-XSRM-L
Catalog No. 266671

Similar to illustration

Delivery program

Equipment supplied			Door coupling rotary handle Mounting brackets Special short extension shaft External warning plate/marketing plate in German/English Black and yellow lightning symbol
Product range			Accessories
Accessories			Main switch assembly kit for side panel mounting
Standard/Approval			UL/CSA, IEC
Construction size			NZM1
Description			Kit for use as a main switch
Function			For direct mounting of circuit-breaker and handle in the side wall of the control cabinet Red-yellow for emergency switching off
Protection class			IP66 UL/CSA Type 4X, Type 12
Door interlock			Lockable in 0 position on handle Narrowest minimum clearance between enclosure side plates of control panel and circuit-breaker is defined by mounting bracket. Extension cannot be used.
Project planning information			External warning plate/designation label can be clipped on. For enhanced busbar tag shroud on the incomer side, please order IP2X protection against contact with a finger.
Actuation			Actuation on the left
For use with			NZM1(-4) PN1(-4), N(S)1(-4)

Notes

Additional terminal arrangement for flange operator with mounting bracket

NZM1-XS(R)M-..., NZM2-XS(R)M-...

Additional terminals K25, K50, K95, K150 → 093827

Actuation:

3 pole
For actuation on the right

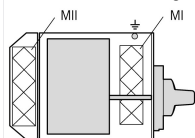

For actuation on the left

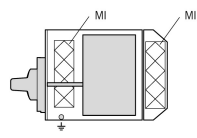

4-Pole
For actuation on the right

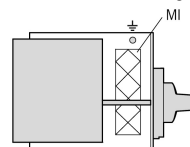

For actuation on the left

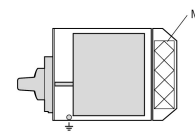

Mounting areas	WE			MII		
Variation options	V1	V2	V3	V4	V1	V2
Maximum number of additional terminals	2 x	-	-	-	-	-
K25	2 x	-	-	-	-	-
K50	-	2 x	-	-	-	-
K95	-	-	1 x	-	1 x	-
K150	-	-	1 x	1 x	-	1 x

Example: In mounting area MI, variation option 1 allows the K25 additional terminal to be mounted twice.

Design verification as per IEC/EN 61439

IEC/EN 61439 design verification			
10.2 Strength of materials and parts			
10.2.2 Corrosion resistance			Meets the product standard's requirements.
10.2.3.1 Verification of thermal stability of enclosures			Meets the product standard's requirements.
10.2.3.2 Verification of resistance of insulating materials to normal heat			Meets the product standard's requirements.
10.2.3.3 Verification of resistance of insulating materials to abnormal heat and fire due to internal electric effects			Meets the product standard's requirements.

10.2.4 Resistance to ultra-violet (UV) radiation			Meets the product standard's requirements.
10.2.5 Lifting			Does not apply, since the entire switchgear needs to be evaluated.
10.2.6 Mechanical impact			Does not apply, since the entire switchgear needs to be evaluated.
10.2.7 Inscriptions			Meets the product standard's requirements.
10.3 Degree of protection of ASSEMBLIES			Does not apply, since the entire switchgear needs to be evaluated.
10.4 Clearances and creepage distances			Meets the product standard's requirements.
10.5 Protection against electric shock			Does not apply, since the entire switchgear needs to be evaluated.
10.6 Incorporation of switching devices and components			Does not apply, since the entire switchgear needs to be evaluated.
10.7 Internal electrical circuits and connections			Is the panel builder's responsibility.
10.8 Connections for external conductors			Is the panel builder's responsibility.
10.9 Insulation properties			
10.9.2 Power-frequency electric strength			Is the panel builder's responsibility.
10.9.3 Impulse withstand voltage			Is the panel builder's responsibility.
10.9.4 Testing of enclosures made of insulating material			Is the panel builder's responsibility.
10.10 Temperature rise			The panel builder is responsible for the temperature rise calculation. Eaton will provide heat dissipation data for the devices.
10.11 Short-circuit rating			Is the panel builder's responsibility. The specifications for the switchgear must be observed.
10.12 Electromagnetic compatibility			Is the panel builder's responsibility. The specifications for the switchgear must be observed.
10.13 Mechanical function			The device meets the requirements, provided the information in the instruction leaflet (IL) is observed.

Technical data ETIM 7.0

Low-voltage industrial components (EG000017) / Handle for power circuit breaker (EC000229)			
Electric engineering, automation, process control engineering / Low-voltage switch technology / Circuit breaker (LV < 1 kV) / Handle for switch devices (ecl@ss10.0.1-27-37-04-14 [AKF012014])			
Lockable			Yes
Colour			Red
Suitable for emergency stop			Yes
With extension shaft			Yes
Suitable for power circuit breaker			Yes
Suitable for switch disconnecter			Yes

Approvals

Product Standards			UL489; CSA-C22.2 No. 5-09; IEC60947, CE marking
UL File No.			E140305
UL Category Control No.			DIHS
CSA File No.			022086
CSA Class No.			1437-01
North America Certification			UL listed, CSA certified
Degree of Protection			IEC: IP66, UL/CSA Type 4X, 12

Dimensions

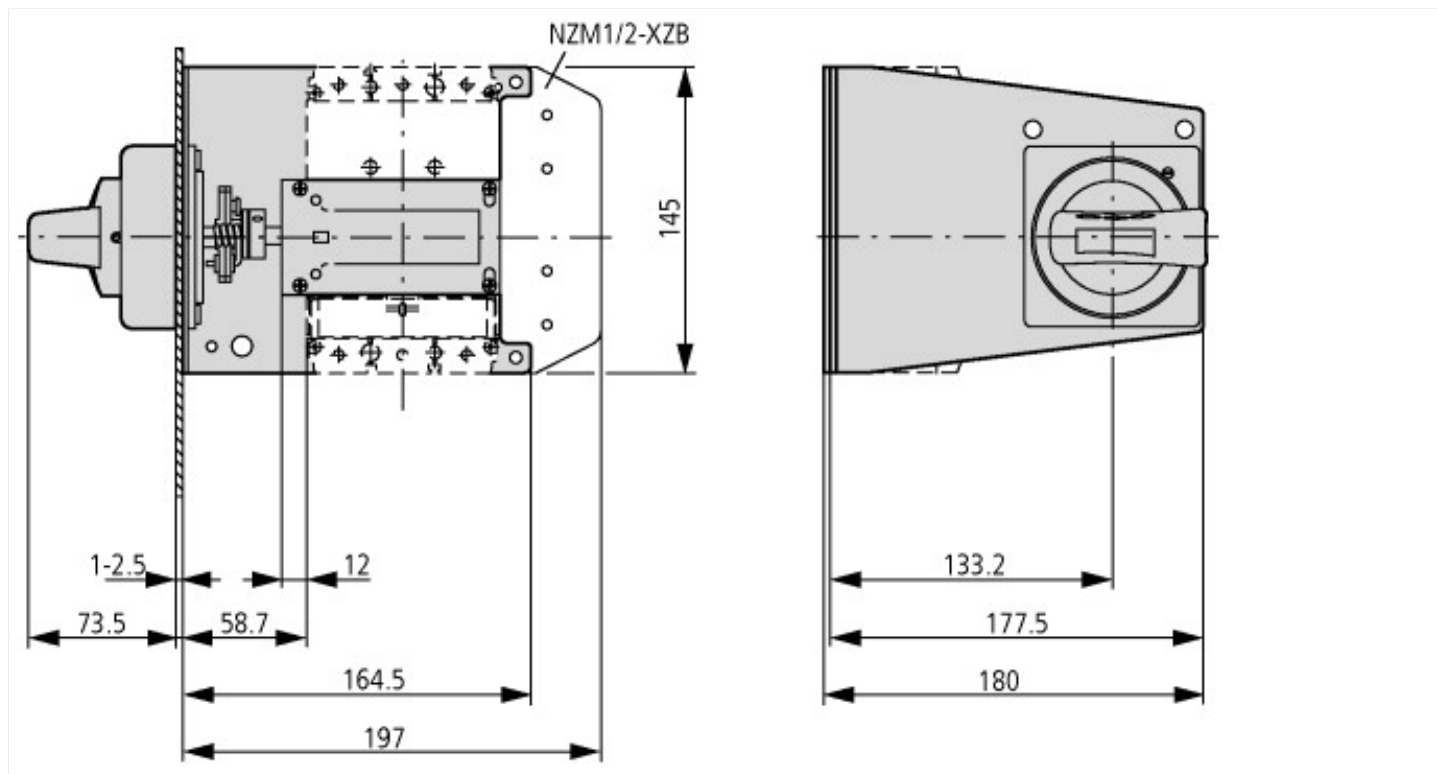



SCATTERGOOD & JOHNSON LTD

ELECTRICAL ENGINEERING & FLUID CONTROL DISTRIBUTORS

Est.1899

At Scattergood & Johnson Ltd, we pride ourselves on being a technical distributor to specialist industries.

Working with a range of quality product suppliers across a number of specialist markets, we are not your average 'box shifter' - we are your technical and supply chain partner.

We fully support every product we sell - for free! Our internal team and external sales engineers can answer any product or application question, no matter the complexity.

Backing up this technical ability is a range of 50,000+ products available from stock for nationwide next day delivery (same day if required!), or you can collect what you need from any of our trade counters around the UK.

Select your specialist interest below to learn more about how we can help.



Online, In Branch and On the Road - Scattergood & Johnson Ltd, there when you need us.

www.scatts.co.uk