

DATASHEET - T3-3-8342/V/SVB-SW



Main switch, T3, 32 A, rear mounting, 3 contact unit(s), 6 pole, STOP function, With black rotary handle and locking ring, Lockable in the 0 (Off) position



Part no. T3-3-8342/V/SVB-SW
Catalog No. 078445

Delivery program

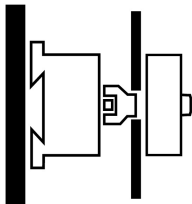
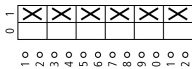
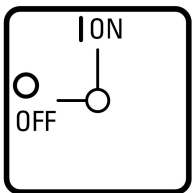
| | | | |
|--|----------------|-----------------|--|
| Product range | | | Main switch maintenance switch Repair switch |
| Part group reference | | | T3 |
| Stop Function | | | STOP function |
| | | | With black rotary handle and locking ring |
| Number of poles | | | 6 pole |
| Locking facility | | | Lockable in the 0 (Off) position |
| Degree of Protection | | | Front IP65 |
| Design | | | rear mounting |
| | | |  |
| Contact sequence | | |  |
| Switching angle | | ° | 90 |
| Design number | | | 8342 |
| Function | | |  |
| Motor rating AC-23A, 50 - 60 Hz | | | |
| 400 V | P | kW | 15 |
| Rated uninterrupted current | I _u | A | 32 |
| Note on rated uninterrupted current I _u | | | Rated uninterrupted current I _u is specified for max. cross-section. |
| Number of contact units | | contact unit(s) | 3 |

Technical data

General

| | | | |
|---------------------------------------|------------------|------|--|
| Standards | | | IEC/EN 60947, VDE 0660, IEC/EN 60204, CSA, UL Switch-disconnector according to IEC/EN 60947-3 |
| Climatic proofing | | | Damp heat, constant, to IEC 60068-2-78 Damp heat, cyclic, to IEC 60068-2-30 |
| Ambient temperature | | | |
| Open | | °C | -25 - +50 |
| Enclosed | | °C | -25 - +40 |
| Overvoltage category/pollution degree | | | III/3 |
| Rated impulse withstand voltage | U _{imp} | V AC | 6000 |
| Mechanical shock resistance | | g | 15 |
| Mounting position | | | As required |

Contacts

| | | | |
|----------------------|--|--|--|
| Mechanical variables | | | |
|----------------------|--|--|--|

| | | | |
|--|--------------|---------------|--|
| Number of poles | | | 6 pole |
| Electrical characteristics | | | |
| Rated operational voltage | U_e | V AC | 690 |
| Rated uninterrupted current | I_u | A | 32 |
| Note on rated uninterrupted current I_u | | | Rated uninterrupted current I_u is specified for max. cross-section. |
| Load rating with intermittent operation, class 12 | | | |
| AB 25 % DF | | $\times I_e$ | 2 |
| AB 40 % DF | | $\times I_e$ | 1.6 |
| AB 60 % DF | | $\times I_e$ | 1.3 |
| Short-circuit rating | | | |
| Fuse | | A gG/gL | 35 |
| Rated short-time withstand current (1 s current) | I_{cw} | A_{rms} | 650 |
| Note on rated short-time withstand current I_{cw} | | | Current for a time of 1 second |
| Rated conditional short-circuit current | I_q | kA | 1 |
| Switching capacity | | | |
| $\cos \varphi$ rated making capacity as per IEC 60947-3 | | A | 320 |
| Rated breaking capacity $\cos \varphi$ to IEC 60947-3 | | A | |
| 230 V | | A | 260 |
| 400/415 V | | A | 260 |
| 500 V | | A | 240 |
| 690 V | | A | 170 |
| Safe isolation to EN 61140 | | | |
| between the contacts | | V AC | 440 |
| Current heat loss per contact at I_e | | W | 1.1 |
| Current heat loss per auxiliary circuit at I_e (AC-15/230 V) | | CO | 1.1 |
| Lifespan, mechanical | Operations | $\times 10^6$ | > 0.5 |
| Maximum operating frequency | Operations/h | | 1200 |
| AC | | | |
| AC-3 | | | |
| Rating, motor load switch | P | kW | |
| 220 V 230 V | P | kW | 5.5 |
| 230 V Star-delta | P | kW | 7.5 |
| 400 V 415 V | P | kW | 11 |
| 400 V Star-delta | P | kW | 15 |
| 500 V | P | kW | 15 |
| 500 V Star-delta | P | kW | 18.5 |
| 690 V | P | kW | 11 |
| 690 V Star-delta | P | kW | 22 |
| Rated operational current motor load switch | | | |
| 230 V | I_e | A | 23.7 |
| 230 V star-delta | I_e | A | 32 |
| 400V 415 V | I_e | A | 23.7 |
| 400 V star-delta | I_e | A | 32 |
| 500 V | I_e | A | 23.7 |
| 500 V star-delta | I_e | A | 32 |
| 690 V | I_e | A | 14.7 |
| 690 V star-delta | I_e | A | 25.5 |
| AC-21A | | | |
| Rated operational current switch | | | |
| 440 V | I_e | A | 32 |
| AC-23A | | | |
| Motor rating AC-23A, 50 - 60 Hz | P | kW | |
| 230 V | P | kW | 7.5 |
| 400 V 415 V | P | kW | 15 |

| | | | |
|---|-------------------|----------|---|
| 500 V | P | kW | 15 |
| 690 V | P | kW | 15 |
| Rated operational current motor load switch | | | |
| 230 V | I_e | A | 32 |
| 400 V 415 V | I_e | A | 32 |
| 500 V | I_e | A | 26.4 |
| 690 V | I_e | A | 17 |
| DC | | | |
| DC-1, Load-break switches L/R = 1 ms | | | |
| Rated operational current | I_e | A | 25 |
| Voltage per contact pair in series | | V | 60 |
| DC-21A | | | |
| Rated operational current | I_e | A | 1 |
| Contacts | | Quantity | 1 |
| DC-23A, motor load switch L/R = 15 ms | | | |
| 24 V | | | |
| Rated operational current | I_e | A | 25 |
| Contacts | | Quantity | 1 |
| 48 V | | | |
| Rated operational current | I_e | A | 25 |
| Contacts | | Quantity | 2 |
| 60 V | | | |
| Rated operational current | I_e | A | 25 |
| Contacts | | Quantity | 3 |
| 120 V | | | |
| Rated operational current | I_e | A | 12 |
| Contacts | | Quantity | 3 |
| 240 V | | | |
| Rated operational current | I_e | A | 5 |
| Contacts | | Quantity | 5 |
| DC-13, Control switches L/R = 50 ms | | | |
| Rated operational current | I_e | A | 20 |
| Voltage per contact pair in series | | V | 24 |
| Control circuit reliability at 24 V DC, 10 mA | Fault probability | H_F | $< 10^{-5}$, < 1 failure in 100,000 switching operations |

Terminal capacities

| | | | |
|--------------------------------------|--|-----------------|----------------------------------|
| Solid or stranded | | mm ² | 1 x (1 - 6) 2 x (1 - 6) |
| Flexible with ferrules to DIN 46228 | | mm ² | 1 x (0.75 - 4) 2 x (0.75 - 4) |
| Terminal screw | | | M4 |
| Tightening torque for terminal screw | | Nm | 1.6 |

Technical safety parameters:

| | | | |
|-------|--|--|---|
| Notes | | | B10 _d values as per EN ISO 13849-1, table C1 |
|-------|--|--|---|

Rating data for approved types

| | | | |
|----------------------------------|-------|------|-------|
| Contacts | | | |
| Rated operational voltage | U_e | V AC | 600 |
| Rated uninterrupted current max. | | | |
| Main conducting paths | | | |
| General use | | A | 25 |
| Auxiliary contacts | | | |
| General Use | I_U | A | 10 |
| Pilot Duty | | | A 600 |
| Switching capacity | | | |
| Maximum motor rating | | | |
| Single-phase | | | |

| | | |
|--|-------|-------------|
| 120 V AC | HP | 1.5 |
| 200 V AC | HP | 3 |
| 240 V AC | HP | 3 |
| Three-phase | | |
| 200 V AC | HP | 3 |
| 240 V AC | HP | 3 |
| 480 V AC | HP | 7.5 |
| 600 V AC | HP | 10 |
| Short Circuit Current Rating | SCCR | |
| Basic Rating | kA | 5 |
| max. Fuse | A | 40 |
| High fault rating | kA | 10 |
| max. Fuse | A | 40, Class J |
| Terminal capacity | | |
| Solid or flexible conductor with ferrule | AWG | 14 - 10 |
| Terminal screw | | M4 |
| Tightening torque | lb-in | 17.7 |

Design verification as per IEC/EN 61439

| | | | |
|--|------------|----|--|
| Technical data for design verification | | | |
| Rated operational current for specified heat dissipation | I_n | A | 32 |
| Heat dissipation per pole, current-dependent | P_{vid} | W | 1.1 |
| Equipment heat dissipation, current-dependent | P_{vid} | W | 0 |
| Static heat dissipation, non-current-dependent | P_{vs} | W | 0 |
| Heat dissipation capacity | P_{diss} | W | 0 |
| Operating ambient temperature min. | | °C | -25 |
| Operating ambient temperature max. | | °C | 50 |
| IEC/EN 61439 design verification | | | |
| 10.2 Strength of materials and parts | | | |
| 10.2.2 Corrosion resistance | | | |
| 10.2.2.1 Verification of thermal stability of enclosures | | | Meets the product standard's requirements. |
| 10.2.2.2 Verification of resistance of insulating materials to normal heat | | | Meets the product standard's requirements. |
| 10.2.2.3 Verification of resistance of insulating materials to abnormal heat and fire due to internal electric effects | | | Meets the product standard's requirements. |
| 10.2.4 Resistance to ultra-violet (UV) radiation | | | UV resistance only in connection with protective shield. |
| 10.2.5 Lifting | | | Does not apply, since the entire switchgear needs to be evaluated. |
| 10.2.6 Mechanical impact | | | Does not apply, since the entire switchgear needs to be evaluated. |
| 10.2.7 Inscriptions | | | Meets the product standard's requirements. |
| 10.3 Degree of protection of ASSEMBLIES | | | Does not apply, since the entire switchgear needs to be evaluated. |
| 10.4 Clearances and creepage distances | | | Meets the product standard's requirements. |
| 10.5 Protection against electric shock | | | Does not apply, since the entire switchgear needs to be evaluated. |
| 10.6 Incorporation of switching devices and components | | | Does not apply, since the entire switchgear needs to be evaluated. |
| 10.7 Internal electrical circuits and connections | | | Is the panel builder's responsibility. |
| 10.8 Connections for external conductors | | | Is the panel builder's responsibility. |
| 10.9 Insulation properties | | | |
| 10.9.2 Power-frequency electric strength | | | Is the panel builder's responsibility. |
| 10.9.3 Impulse withstand voltage | | | Is the panel builder's responsibility. |
| 10.9.4 Testing of enclosures made of insulating material | | | Is the panel builder's responsibility. |
| 10.10 Temperature rise | | | The panel builder is responsible for the temperature rise calculation. Eaton will provide heat dissipation data for the devices. |
| 10.11 Short-circuit rating | | | Is the panel builder's responsibility. The specifications for the switchgear must be observed. |
| 10.12 Electromagnetic compatibility | | | Is the panel builder's responsibility. The specifications for the switchgear must be observed. |
| 10.13 Mechanical function | | | The device meets the requirements, provided the information in the instruction leaflet (IL) is observed. |

Technical data ETIM 7.0

| Low-voltage industrial components (EG000017) / Switch disconnecter (EC000216) | | | |
|--|--|----|--|
| Electric engineering, automation, process control engineering / Low-voltage switch technology / Off-load switch, circuit breaker, control switch / Switch disconnecter (ec@ss10.0.1-27-37-14-03 [AKF060013]) | | | |
| Version as main switch | | | Yes |
| Version as maintenance-/service switch | | | Yes |
| Version as safety switch | | | No |
| Version as emergency stop installation | | | No |
| Version as reversing switch | | | No |
| Number of switches | | | 1 |
| Max. rated operation voltage Ue AC | | V | 690 |
| Rated operating voltage | | V | 690 - 690 |
| Rated permanent current Iu | | A | 32 |
| Rated permanent current at AC-23, 400 V | | A | 32 |
| Rated permanent current at AC-21, 400 V | | A | 32 |
| Rated operation power at AC-3, 400 V | | kW | 11 |
| Rated short-time withstand current Icw | | kA | 0.65 |
| Rated operation power at AC-23, 400 V | | kW | 15 |
| Switching power at 400 V | | kW | 15 |
| Conditioned rated short-circuit current Iq | | kA | 1 |
| Number of poles | | | 6 |
| Number of auxiliary contacts as normally closed contact | | | 0 |
| Number of auxiliary contacts as normally open contact | | | 0 |
| Number of auxiliary contacts as change-over contact | | | 0 |
| Motor drive optional | | | No |
| Motor drive integrated | | | No |
| Voltage release optional | | | No |
| Device construction | | | Built-in device fixed built-in technique |
| Suitable for ground mounting | | | Yes |
| Suitable for front mounting 4-hole | | | No |
| Suitable for front mounting centre | | | No |
| Suitable for distribution board installation | | | No |
| Suitable for intermediate mounting | | | Yes |
| Colour control element | | | Black |
| Type of control element | | | Door coupling rotary drive |
| Interlockable | | | Yes |
| Type of electrical connection of main circuit | | | Screw connection |
| Degree of protection (IP), front side | | | IP65 |
| Degree of protection (NEMA) | | | 12 |

Approvals

| | | | |
|-----------------------------|--|--|--|
| Product Standards | | | UL 60947-4-1; CSA - C22.2 No. 60947-4-1-14; CSA-C22.2 No. 94; IEC/EN 60947-3; CE marking |
| UL File No. | | | E36332 |
| UL Category Control No. | | | NLRV |
| CSA File No. | | | 12528 |
| CSA Class No. | | | 3211-05 |
| North America Certification | | | UL listed, CSA certified |
| Suitable for | | | Branch circuits, suitable as motor disconnect |
| Degree of Protection | | | IEC: IP65; UL/CSA Type 1, 12 |

Dimensions

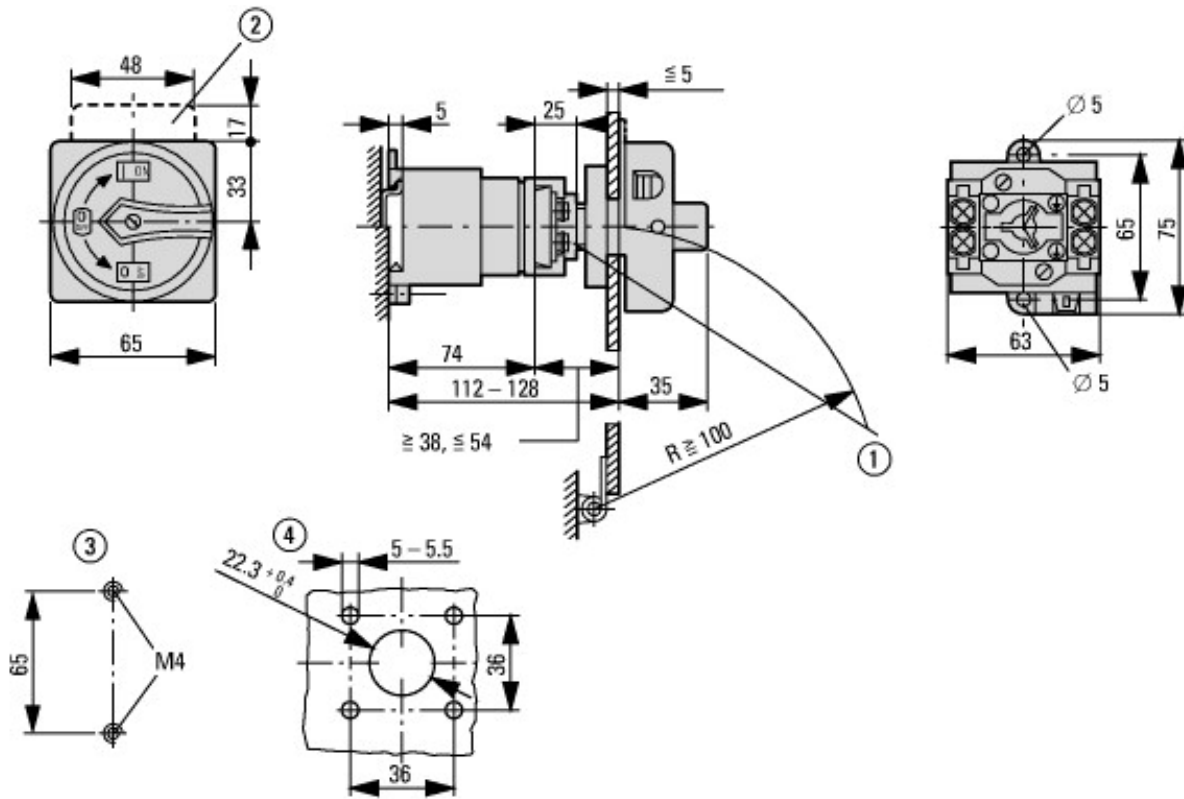

- ① Shaft and interlock extension with ZAV-T0 + ZVV-T0 possible, max. 4 x 25 = 100 mm
- ② ZFS-... Label mount not included as standard
- ③ Drilling dimensions base
- ④ Drilling dimensions door

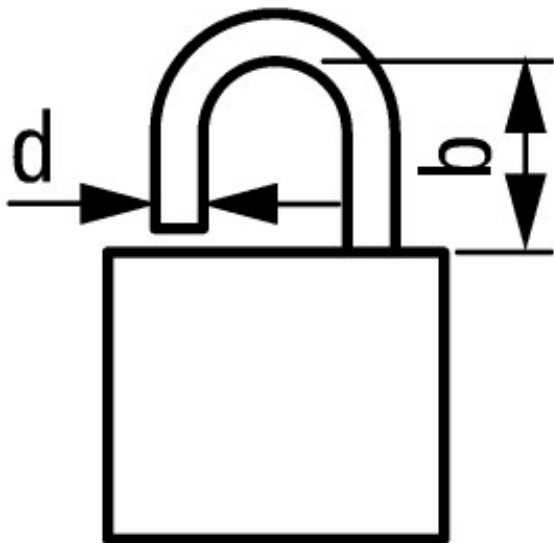

d = 4 - 8 mm
b + d ≤ 47 mm
d = 0.16 - 0.31"
b + d ≤ 1.85"

≤ 3 padlocks



SCATTERGOOD & JOHNSON LTD

ELECTRICAL ENGINEERING & FLUID CONTROL DISTRIBUTORS

Est.1899

At Scattergood & Johnson Ltd, we pride ourselves on being a technical distributor to specialist industries.

Working with a range of quality product suppliers across a number of specialist markets, we are not your average 'box shifter' - we are your technical and supply chain partner.

We fully support every product we sell - for free! Our internal team and external sales engineers can answer any product or application question, no matter the complexity.

Backing up this technical ability is a range of 50,000+ products available from stock for nationwide next day delivery (same day if required!), or you can collect what you need from any of our trade counters around the UK.

Select your specialist interest below to learn more about how we can help.



Online, In Branch and On the Road - Scattergood & Johnson Ltd, there when you need us.

www.scatts.co.uk