

**DATASHEET - EASY806-DC-SWD****Control relay, 24 V DC, 4DI(2DI, 2DO), easyNet, SmartWire-DT**

**Part no.** EASY806-DC-SWD  
**Catalog No.** 152902  
**Alternate Catalog No.** EASY806-DC-SWD  
**EL-Nummer (Norway)** 4520981

**Delivery program**

Product range			SmartWire-DT coordinators
Basic function			easy800 with SmartWire-DT
Description			Combines the functionality of an easy800 with direct connection to SmartWire-DT communication system Up to 99 SmartWire-DT modules with a total of up to 166 digital inputs/outputs and/or up to 128 analog inputs/outputs can be connected via a SmartWire-DT line
<b>Inputs</b>			
Digital			4
Of which can be used as outputs			2
SmartWire-DT			83
<b>Outputs</b>			
Quantity of outputs			Transistor: 2
Outputs		Number	2
Transistor			2
SmartWire-DT			83
<b>Additional features</b>			
Real time clock			#
Expansions			SmartWire-DT Networkable (easyNet)
Supply voltage			24 V DC
Software			EASY-SOFT-PRO
Connection type			screw terminal
<b>Notes</b>			
Depending on the hardware, such as integrated analog input/output not supported			
Count functions: 2 x incremental value counter up/down (per 2 inputs); 4 x high-speed counter single-channel (per 1 input);			
4 x frequency counters (per 1 input)			
2 x pulse-width modulated outputs (2 counter inputs omitted)			

**Technical data****General**

Standards			EN 55011, EN 55022, IEC/EN 61000-4, IEC 60068-2-6, IEC 60068-2-27
Approvals			CSA UL EAC
Dimensions (W x H x D)		mm	35 x 110 x 125.5 (2 PE)
Weight		kg	0.16
Mounting			Top-hat rail IEC/EN 60715, 35 mm or screw fixing using fixing brackets ZB4-101-GF1 (accessories)

**Terminal capacities**

Solid		mm <sup>2</sup>	0.2/1.5 (AWG 24 - 16)
Flexible with ferrule		mm <sup>2</sup>	0.2/1.5 (AWG 24 - 16)

**Climatic environmental conditions**

Operating ambient temperature		°C	In accordance with IEC 60068-2-1, -25 - +55
Condensation			Take appropriate measures to prevent condensation
Storage	9	°C	In accordance with IEC 60068-2-1, -2, -14 -40 - +70

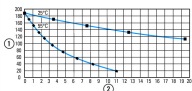
relative humidity		%	in accordance with IEC 60068-2-30, IEC 60068-2-78 5 - 95
Air pressure (operation)		hPa	795 - 1080
<b>Ambient conditions, mechanical</b>			
Protection type (IEC/EN 60529, EN50178, VBG 4)			IP20
Vibrations		Hz	In accordance with IEC 60068-2-6 constant amplitude 0.15 mm: 10 - 57 constant acceleration 2 g: 57 - 150
Mechanical shock resistance (IEC/EN 60068-2-27) semi-sinusoidal 15 g/11 ms		Impacts	18
Drop to IEC/EN 60068-2-31	Drop height	mm	50
Free fall, packaged (IEC/EN 60068-2-32)		m	0.3
Mounting position			Vertical or horizontal
<b>Electromagnetic compatibility (EMC)</b>			
Overvoltage category/pollution degree			III/2
Electrostatic discharge (ESD)			
applied standard			according to IEC EN 61000-4-2
Air discharge		kV	8
Contact discharge		kV	6
Electromagnetic fields (RFI) to IEC EN 61000-4-3		V/m	0.8 - 1.0 GHz: 10 1.4 - 2 GHz: 3 2.0 - 2.7 GHz: 1
Radio interference suppression			EN 55011 Class B
Burst		kV	according to IEC/EN 61000-4-4 Supply cables: 2 Signal cables: 2 easyNet: 2 SWD lines: 2
power pulses (Surge)			according to IEC/EN 61000-4-5 1 kV (supply cables, symmetrical)
Immunity to line-conducted interference to (IEC/EN 61000-4-6)		V	10
<b>Insulation resistance</b>			
Clearance in air and creepage distances			EN 50178, UL 508, CSA C22.2, No. 142
Insulation resistance			EN 50178
<b>Back-up of real-time clock</b>			
Back-up of real-time clock			
			① Backup time (hours) with fully charged double layer capacitor ② Service life (years)
Accuracy of real-time clock to inputs		s/day	typ. $\pm 2$ ( $\pm 0.2$ h/Year)  depending on ambient air temperature fluctuations of up to $\pm 5$ s/day ( $\pm 0.5$ h/year) are possible
<b>Repetition accuracy of timing relays</b>			
Accuracy of timing relays (of values)		%	$\pm 0.02$
Resolution			
Range "S"		ms	5
Range "M:S"		s	1
Range "H:M"		min	1
<b>Retentive memory</b>			
Write cycles of the retentive memory			$10^{14}$ (read/write cycles)
<b>Power supply</b>			
Rated operational voltage	$U_e$	V	24 DC (-15/+20%)
Permissible range	$U_e$		20.4 - 28.8 V DC
Residual ripple		%	$\leq 5$
Siemens MPI, (optional)			yes
Input current			normally 900 mA at $U_e$
Inrush current and length		A	12.5 for 6 ms
Voltage dips		ms	$\leq$ In accordance with IEC 61131-2 $\leq 10$
Fuse		A	$\geq 3$ A (T) (e.g FAZ C3)
Power loss	P	W	Normally 1
Note on heat dissipation			Current consumption at 24 V DC

**Digital inputs 24 V DC**

Number			4
Status Display			LED
Potential isolation			from power supply: no between digital inputs: no from the outputs: no to COM interface: yes to easyNet: yes to AUX: yes to SmartWire-DT: no
Rated operational voltage	$U_e$	V DC	24
Input voltage		V DC	Signal 0: $\leq 5$ (I1 - I4) Signal 1: $\geq 15$ (I1 - I4)
Input current at signal 1		mA	I1 - I4: 3.9
Deceleration time		ms	20 (0 -> 1/1 -> 0, Debounce ON) normally 0.025 (0 -> 1/1 -> 0, Debounce OFF)
Cable length		m	100 (unshielded)
Frequency counter			
Number			4 (I1, I2, I3, I4)
Counter frequency		kHz	$\leq 5$
Pulse shape			Square
Pulse pause ratio			1:1
Cable length		m	$\leq 20$ (screened)
Incremental counter			
Number of counter inputs			2 (I1 + I2, I3 + I4)
Counter frequency		kHz	$\leq 5$
Pulse shape			Square
Signal offset			90°
Pulse pause ratio			1:1
Rapid counter inputs			
Number			4 (I1, I2, I3, I4)
Cable length		m	$\leq 20$ (screened)
Counter frequency		kHz	$\leq 5$
Pulse shape			Square
Pulse pause ratio			1:1

**Transistor outputs**

Number			2
Potential isolation			from power supply: no From the inputs: yes: no to COM interface: yes to easyNet: yes to AUX: yes
Rated operational current at signal „1“ DC per channel	$I_e$	A	max. 0.1
Lamp load without $R_v$ per channel		W	1.2
Residual current on 0 signal per channel		mA	< 0.1
Max. output voltage		V	2.5 (signal 0 at external load < 10 M $\Omega$ ) $U = U_e - 2$ V (signal 1 at $I_e = 0.1$ A)
Short-circuit protection			Yes, electronic (Q1 - Q2)
Short-circuit tripping current for $R_a \leq 10$ m $\Omega$		A	0.15 - 0.35 per output depending on number of active channels and their load
Peak short-circuit current		A	10 A/80 ms (on short-circuit) 10 A/20 ms (on attempted restart of device after 10s)
Thermal cutout			no
Output status indication			LED

**Supply voltage  $U_{Aux}$** 

Rated operational voltage	$U_{Aux}$	V	24 V DC (-15/+20%)
Permissible range			20.4 - 28.8 V DC
Output voltage SWD-OUT			$U_e - 0.3$ V
Siemens MPI, (optional)			yes
Residual ripple on the input voltage		%	$\leq 5$
Max. current	$I_{max}$	A	3 (IEC) 2 (UL)

Short-circuit rating			no
Heat dissipation		W	Normally 1 W at 24 V DC
Potential isolation			from power supply POW: yes From the inputs: yes from the outputs: yes to COM interface: yes to easyNet: yes to SmartWire-DT: yes
Power loss	P	W	1

### SmartWire-DT supply voltage

Rated operating voltage	$U_e$	V	$14.5 \pm 3 \%$
max. current	$I_{max}$	A	0.7
Short-circuit rating			Yes
Potential isolation			from power supply POW: no From the inputs: yes: no from the outputs: no to COM interface: yes to easyNet: yes to AUX: yes

### SmartWire-DT network

Station type			Master
Number of SmartWire-DT slaves			Max. 600
Baud Rates		kBd	125/250
Address allocation			Automatically (via Configuration button)
Status indication		LED	SWD-LED: orange/green/red Config. LED: green/red
Connections			Plug, 8-pole
Plug connector			Blade terminal SWD4-8MF2
Bus termination			Integrated in the device SmartWire-DT line end with SWD4-RC8-10

### Network easyNet

Module		Count	Max. 8
Data transfer rate/distance			1000 KBit/s, 6 m 500 KBit/s, 25 m 250 Kbit/s, 40 m 125 Kbit/s, 300 m 50 KBit/s, 300 m 20 KBit/s, 700 m 10 KBit/s, 1000 m Lengths from 40 m can be obtained only with cables with reinforced cross-section and terminal adapter.
Potential isolation			from power supply POW: yes From the inputs: yes from the outputs: yes to COM interface: yes to SmartWire-DT: yes to AUX: yes
Bus termination (first and last station)			yes
Terminal types			RJ45, 8-polig
Terminal capacity			up to 1000 m, < 16 mΩ/m: 1.5 (AWG: 16) up to 600 m, < 26 mΩ/m: 0.75 - 0.8 (AWG: 18) up to 600 m, < 26 mΩ/m: 0.5 - 0.6 (AWG: 20, 19) up to 400 m, < 40 mΩ/m: 0.34 - 0.5 (AWG: 22, 21, 20) up to 250 m, < 60 mΩ/m: 0.25 - 0.34 (AWG: 23, 22) up to 175 m, < 70 mΩ/m: 0.13 (AWG: 26) up to 40 m, < 140 mΩ/m: 1.5 (AWG: 16)

### Design verification as per IEC/EN 61439

Technical data for design verification			
Rated operational current for specified heat dissipation	$I_n$	A	0
Heat dissipation per pole, current-dependent	$P_{vid}$	W	0
Equipment heat dissipation, current-dependent	$P_{vid}$	W	0
Static heat dissipation, non-current-dependent	$P_{vs}$	W	6
Heat dissipation capacity	$P_{diss}$	W	0
Operating ambient temperature min.		°C	-25
Operating ambient temperature max.		°C	55
IEC/EN 61439 design verification			
10.2 Strength of materials and parts			

10.2.2 Corrosion resistance		Meets the product standard's requirements.
10.2.3.1 Verification of thermal stability of enclosures		Meets the product standard's requirements.
10.2.3.2 Verification of resistance of insulating materials to normal heat		Meets the product standard's requirements.
10.2.3.3 Verification of resistance of insulating materials to abnormal heat and fire due to internal electric effects		Meets the product standard's requirements.
10.2.4 Resistance to ultra-violet (UV) radiation		Meets the product standard's requirements.
10.2.5 Lifting		Does not apply, since the entire switchgear needs to be evaluated.
10.2.6 Mechanical impact		Does not apply, since the entire switchgear needs to be evaluated.
10.2.7 Inscriptions		Meets the product standard's requirements.
10.3 Degree of protection of ASSEMBLIES		Meets the product standard's requirements.
10.4 Clearances and creepage distances		Meets the product standard's requirements.
10.5 Protection against electric shock		Does not apply, since the entire switchgear needs to be evaluated.
10.6 Incorporation of switching devices and components		Does not apply, since the entire switchgear needs to be evaluated.
10.7 Internal electrical circuits and connections		Is the panel builder's responsibility.
10.8 Connections for external conductors		Is the panel builder's responsibility.
10.9 Insulation properties		
10.9.2 Power-frequency electric strength		Is the panel builder's responsibility.
10.9.3 Impulse withstand voltage		Is the panel builder's responsibility.
10.9.4 Testing of enclosures made of insulating material		Is the panel builder's responsibility.
10.10 Temperature rise		The panel builder is responsible for the temperature rise calculation. Eaton will provide heat dissipation data for the devices.
10.11 Short-circuit rating		Is the panel builder's responsibility.
10.12 Electromagnetic compatibility		Is the panel builder's responsibility.
10.13 Mechanical function		The device meets the requirements, provided the information in the instruction leaflet (IL) is observed.

## Technical data ETIM 7.0

PLC's (EG000024) / Logic module (EC001417)		
Electric engineering, automation, process control engineering / Control / Programmable logic control (SPS) / Logic module (ecl@ss10.0.1-27-24-22-16 [AKE539014])		
Supply voltage AC 50 Hz	V	0 - 0
Supply voltage AC 60 Hz	V	0 - 0
Supply voltage DC	V	20.4 - 28.8
Voltage type of supply voltage		DC
Switching current	A	0.1
Number of analogue inputs		0
Number of analogue outputs		0
Number of digital inputs		4
Number of digital outputs		2
With relay output		No
Number of HW-interfaces industrial Ethernet		0
Number of interfaces PROFINET		0
Number of HW-interfaces RS-232		0
Number of HW-interfaces RS-422		0
Number of HW-interfaces RS-485		0
Number of HW-interfaces serial TTY		0
Number of HW-interfaces USB		0
Number of HW-interfaces parallel		0
Number of HW-interfaces Wireless		0
Number of HW-interfaces other		3
With optical interface		No
Supporting protocol for TCP/IP		No
Supporting protocol for PROFIBUS		No
Supporting protocol for CAN		No
Supporting protocol for INTERBUS		No
Supporting protocol for ASI		No
Supporting protocol for KNX		No

Supporting protocol for MODBUS			No
Supporting protocol for Data-Highway			No
Supporting protocol for DeviceNet			No
Supporting protocol for SUCONET			No
Supporting protocol for LON			No
Supporting protocol for PROFINET IO			No
Supporting protocol for PROFINET CBA			No
Supporting protocol for SERCOS			No
Supporting protocol for Foundation Fieldbus			No
Supporting protocol for EtherNet/IP			No
Supporting protocol for AS-Interface Safety at Work			No
Supporting protocol for DeviceNet Safety			No
Supporting protocol for INTERBUS-Safety			No
Supporting protocol for PROFIsafe			No
Supporting protocol for SafetyBUS p			No
Supporting protocol for other bus systems			Yes
Radio standard Bluetooth			No
Radio standard WLAN 802.11			No
Radio standard GPRS			No
Radio standard GSM			No
Radio standard UMTS			No
IO link master			No
Redundancy			No
With display			No
Degree of protection (IP)			IP20
Basic device			Yes
Expandable			Yes
Expansion device			No
With timer			Yes
Rail mounting possible			Yes
Wall mounting/direct mounting			Yes
Front build in possible			No
Rack-assembly possible			No
Suitable for safety functions			No
Category according to EN 954-1			None
SIL according to IEC 61508			None
Performance level acc. EN ISO 13849-1			None
Appendant operation agent (Ex ia)			No
Appendant operation agent (Ex ib)			No
Explosion safety category for gas			None
Explosion safety category for dust			None
Width		mm	35
Height		mm	110
Depth		mm	125.5

## Approvals

Product Standards			IEC/EN see Technical Data; UL508; CSA C22.2 No. 142-M1987
UL File No.			E135462
UL Category Control No.			NRAQ, NRAQ7
CSA File No.			UL report applies to both US and Canada
CSA Class No.			2252-01 + 2258-02
North America Certification			UL listed, certified by UL for use in Canada
Degree of Protection			IEC: IP20, UL/CSA Type: -

**Dimensions**

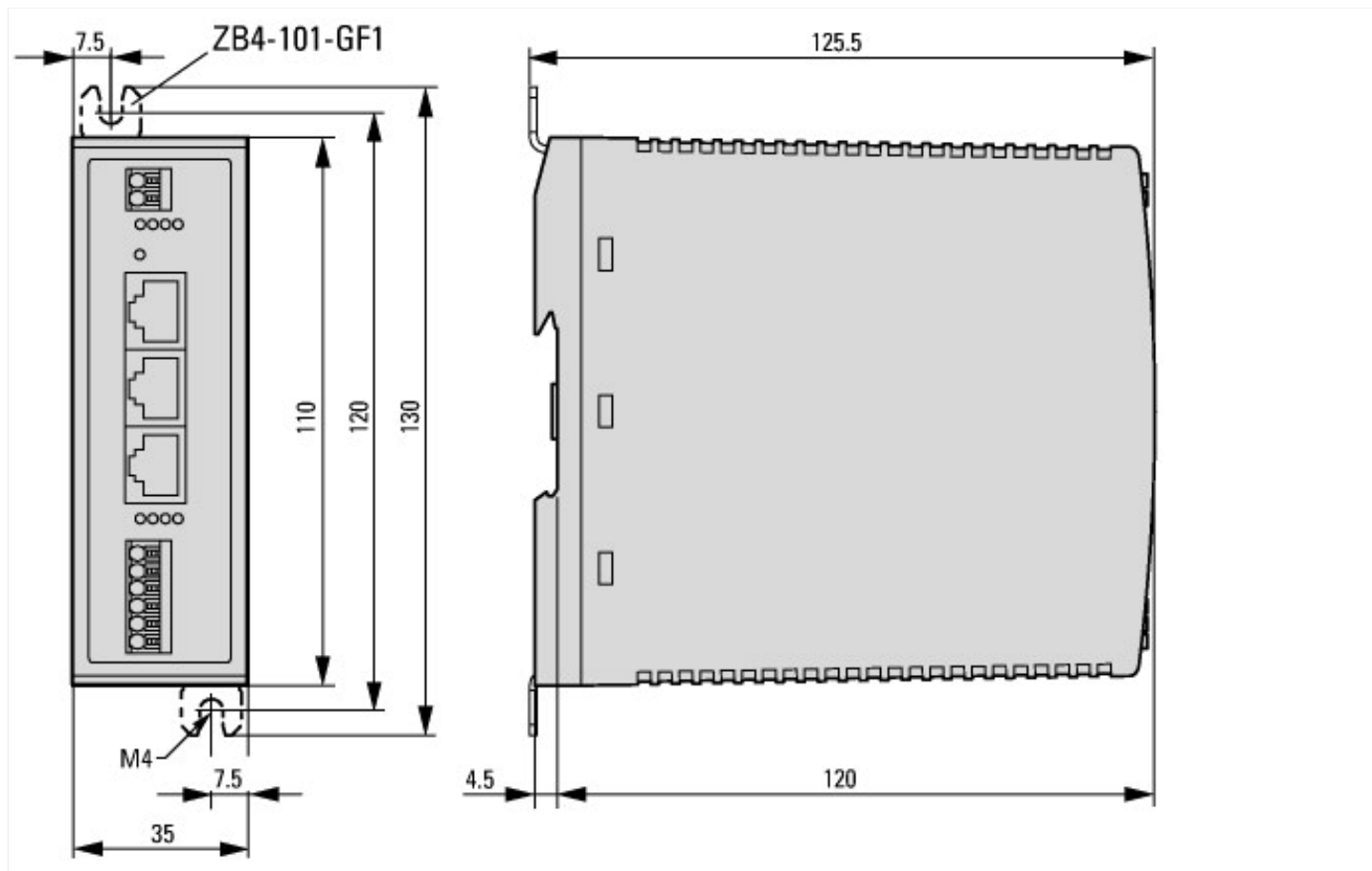



# SCATTERGOOD & JOHNSON LTD

ELECTRICAL ENGINEERING & FLUID CONTROL DISTRIBUTORS

Est.1899

At Scattergood & Johnson Ltd, we pride ourselves on being a technical distributor to specialist industries.

Working with a range of quality product suppliers across a number of specialist markets, we are not your average 'box shifter' - we are your technical and supply chain partner.

We fully support every product we sell - for free! Our internal team and external sales engineers can answer any product or application question, no matter the complexity.

Backing up this technical ability is a range of 50,000+ products available from stock for nationwide next day delivery (same day if required!), or you can collect what you need from any of our trade counters around the UK.

Select your specialist interest below to learn more about how we can help.



Online, In Branch and On the Road - Scattergood & Johnson Ltd, there when you need us.

# [www.scatts.co.uk](http://www.scatts.co.uk)