

DATASHEET - EU5C-SWD-ETHERCAT**SWD gateway; 99 SWD cards on EtherCAT**

Part no. EU5C-SWD-ETHERCAT
Catalog No. 177354
Alternate Catalog No. EU5C-SWD-ETHERCAT

**Delivery program**

Product range		SmartWire-DT coordinators
Function		For connection to an EtherCAT fieldbus as a slave
Short Description		Used to connect the SmartWire-DT communication system to industrial field bus systems. Powers SmartWire-DT modules and switchgear
Description		SmartWire-DT gateway for connecting up to 99 SmartWire-DT modules to an Industrial Ethernet network and for powering the SmartWire-DT modules and switchgear. A connection to EtherCAT can be established using the integrated 100 Mbit/s Ethernet switch as slave. The gateway features a separate USB diagnostic interface (mini USB).
Accessories		Connection of up to 99 SWD slaves

Technical data**General**

Standards		IEC/EN 61131-2
Approvals		
Approvals		UL CSA
Dimensions (W x H x D)	mm	35 x 90 x 124
Weight	kg	0.16
Mounting		Top-hat rail IEC/EN 60715, 35 mm or screw fixing using fixing brackets ZB4-101-GF1 (accessories)
Mounting position		As required

Ambient conditions, mechanical

Protection type (IEC/EN 60529, EN50178, VBG 4)		IP20
Vibrations (IEC/EN 61131-2:2008)		
Constant amplitude 3,5 mm	Hz	5 - 9
Constant acceleration 1 g	Hz	9 - 150
Mechanical shock resistance (IEC/EN 60068-2-27) semi-sinusoidal 15 g/11 ms	Impacts	9
Drop to IEC/EN 60068-2-31	Drop height mm	50
Free fall, packaged (IEC/EN 60068-2-32)	m	1

Electromagnetic compatibility (EMC)

Overvoltage category		II
Pollution degree		2
Electrostatic discharge (IEC/EN 61131-2:2008)		
Air discharge (Level 3)	kV	8
Contact discharge (Level 2)	kV	4
Electromagnetic fields (IEC/EN 61131-2:2008)		
80 - 1000 MHz	V/m	10
1.4 - 2 GHz	V/m	3
2 - 2.7 GHz	V/m	1
Radio interference suppression		EN 55011 Class A
Burst (IEC/EN 61131-2:2008, Level 3)		
Supply cable	kV	2
Fieldbus cable	kV	1
SmartWire-DT cable	kV	1
Surge (IEC/EN 61131-2:2008, Level 1)		
Supply cable		0.5 kV
Radiated RFI (IEC/EN 61131-2:2008, Level 3)	V	10

Operating conditions

Climatic environmental conditions			
Climatic proofing			In accordance with IEC 60068-2
Ambient temperature			
Operation	θ	°C	-25 - +55
Storage	θ	°C	-40 - +70
Atmospheric conditions			
Relative humidity, non-condensing (IEC/EN 60068-2-30)		%	5 - 95
Air pressure (operation)		hPa	795 - 1080

Supply voltage U_{Aux}

Rated operational voltage	U _{Aux}	V	24 V DC (-15/+20%)
Residual ripple on the input voltage		%	≤ 5
Protection against polarity reversal			Yes
Max. current	I _{max}	A	3
Short-circuit rating			no, external fuse FAZ Z3
Power loss	P	W	Normally 1
Potential isolation			No
Rated operating voltage of 24-V-DC slaves		V	typ. U _{Aux} - 0.2

Supply voltage U_{Pow}

Supply voltage	U _{Pow}	V	24 V DC (-15/+20%)
Input voltage ripple		%	≤ 5
Siemens MPI, (optional)			yes
Rated current	I	A	0.7
Overload proof			yes
Inrush current and duration		A	44 A/2 ms
Heat dissipation at 24 V DC		W	4.4
Potential isolation between U _{Pow} and 15 V SmartWire-DT supply voltage			No
Bridging voltage dips		ms	10
Repetition rate		s	1
Status indication		LED	yes

SmartWire-DT supply voltage

Rated operating voltage	U _e	V	14,5 ± 3 %
max. current	I _{max}	A	0.7
Short-circuit rating			Yes

Connection supply voltages

Connection type			Push in terminals
Solid		mm ²	0.2 - 1.5
Flexible with ferrule		mm ²	0.25 - 1.5
UL/CSA solid or stranded		AWG	24 - 16

SmartWire-DT network

Station type			SmartWire-DT master
Number of SmartWire-DT slaves			99
Baud Rates		kBd	125 250
Status indication		LED	SmartWire-DT master LED: red/green Configurations LED: red/green
Connections			Plug, 8-pole
Plug connector			Blade terminal SWD4-8MF2

Fieldbus interface

Module type			EtherCAT slave
Protocol			EtherCAT
Input data, max.		Byte	800
Output data, max.		Byte	642
Baud Rate			
Baud Rates			100 MBit/s
Station address			IP
Address allocation			via EtherCAT

Status display interface	Multi colour LED	APL, RUN, ERR, L/A
Connection design for field bus		2 x RJ45 (2-channel switch)
Potential isolation		Yes

Technical data in sheet catalogue

Other technical data (sheet catalogue)		Technical data
Notes		If contactors with a total current consumption > 3 A are connected, a power feeder module EU5C-SWD-PF1/2 has to be used. If SWD modules with a total current consumption > 0.7 A are connected, a power feeder module EU5C-SWD-PF2 has to be used.

Design verification as per IEC/EN 61439

Technical data for design verification			
Rated operational current for specified heat dissipation	I_n	A	0
Heat dissipation per pole, current-dependent	P_{vid}	W	0
Equipment heat dissipation, current-dependent	P_{vid}	W	0
Static heat dissipation, non-current-dependent	P_{vs}	W	1
Heat dissipation capacity	P_{diss}	W	0
Operating ambient temperature min.		°C	-25
Operating ambient temperature max.		°C	55
Degree of Protection			IP20
IEC/EN 61439 design verification			
10.2 Strength of materials and parts			
10.2.2 Corrosion resistance			Meets the product standard's requirements.
10.2.3.1 Verification of thermal stability of enclosures			Meets the product standard's requirements.
10.2.3.2 Verification of resistance of insulating materials to normal heat			Meets the product standard's requirements.
10.2.3.3 Verification of resistance of insulating materials to abnormal heat and fire due to internal electric effects			Meets the product standard's requirements.
10.2.4 Resistance to ultra-violet (UV) radiation			Meets the product standard's requirements.
10.2.5 Lifting			Does not apply, since the entire switchgear needs to be evaluated.
10.2.6 Mechanical impact			Does not apply, since the entire switchgear needs to be evaluated.
10.2.7 Inscriptions			Meets the product standard's requirements.
10.3 Degree of protection of ASSEMBLIES			Meets the product standard's requirements.
10.4 Clearances and creepage distances			Meets the product standard's requirements.
10.5 Protection against electric shock			Does not apply, since the entire switchgear needs to be evaluated.
10.6 Incorporation of switching devices and components			Does not apply, since the entire switchgear needs to be evaluated.
10.7 Internal electrical circuits and connections			Is the panel builder's responsibility.
10.8 Connections for external conductors			Is the panel builder's responsibility.
10.9 Insulation properties			
10.9.2 Power-frequency electric strength			Is the panel builder's responsibility.
10.9.3 Impulse withstand voltage			Is the panel builder's responsibility.
10.9.4 Testing of enclosures made of insulating material			Is the panel builder's responsibility.
10.10 Temperature rise			The panel builder is responsible for the temperature rise calculation. Eaton will provide heat dissipation data for the devices.
10.11 Short-circuit rating			Is the panel builder's responsibility.
10.12 Electromagnetic compatibility			Is the panel builder's responsibility.
10.13 Mechanical function			The device meets the requirements, provided the information in the instruction leaflet (IL) is observed.

Technical data ETIM 7.0

PLC's (EG000024) / Fieldbus, decenter. periphery - communication module (EC001604)			
Electric engineering, automation, process control engineering / Control / Field bus, decentralized peripheral / Field bus, decentralized peripheral - communications module (ecl@ss10.0.1-27-24-26-08 [BAA073013])			
Supply voltage AC 50 Hz		V	0 - 0
Supply voltage AC 60 Hz		V	0 - 0
Supply voltage DC		V	20.4 - 28.8
Voltage type of supply voltage			DC
Supporting protocol for TCP/IP			No
Supporting protocol for PROFIBUS			No

Supporting protocol for CAN			No
Supporting protocol for INTERBUS			No
Supporting protocol for ASI			No
Supporting protocol for KNX			No
Supporting protocol for MODBUS			No
Supporting protocol for Data-Highway			No
Supporting protocol for DeviceNet			No
Supporting protocol for SUCONET			No
Supporting protocol for LON			No
Supporting protocol for SERCOS			No
Supporting protocol for PROFINET IO			No
Supporting protocol for PROFINET CBA			No
Supporting protocol for Foundation Fieldbus			No
Supporting protocol for EtherNet/IP			No
Supporting protocol for AS-Interface Safety at Work			No
Supporting protocol for DeviceNet Safety			No
Supporting protocol for INTERBUS-Safety			No
Supporting protocol for PROFIsafe			No
Supporting protocol for SafetyBUS p			No
Supporting protocol for other bus systems			Yes
Radio standard Bluetooth			No
Radio standard WLAN 802.11			No
Radio standard GPRS			No
Radio standard GSM			No
Radio standard UMTS			No
IO link master			No
System accessory			Yes
Degree of protection (IP)			IP20
With potential separation			No
Fieldbus connection over separate bus coupler possible			No
Rail mounting possible			Yes
Wall mounting/direct mounting			Yes
Front build in possible			No
Rack-assembly possible			No
Suitable for safety functions			Yes
Category according to EN 954-1			
SIL according to IEC 61508			None
Performance level acc. EN ISO 13849-1			None
Appendant operation agent (Ex ia)			No
Appendant operation agent (Ex ib)			No
Explosion safety category for gas			None
Explosion safety category for dust			None
Width		mm	35
Height		mm	90
Depth		mm	127

Approvals

UL File No.			E221530
UL Category Control No.			NRQA
CSA File No.			UL report applies to both US and Canada
North America Certification			UL listed, CSA certified
Specially designed for North America			No
Current Limiting Circuit-Breaker			No

Dimensions

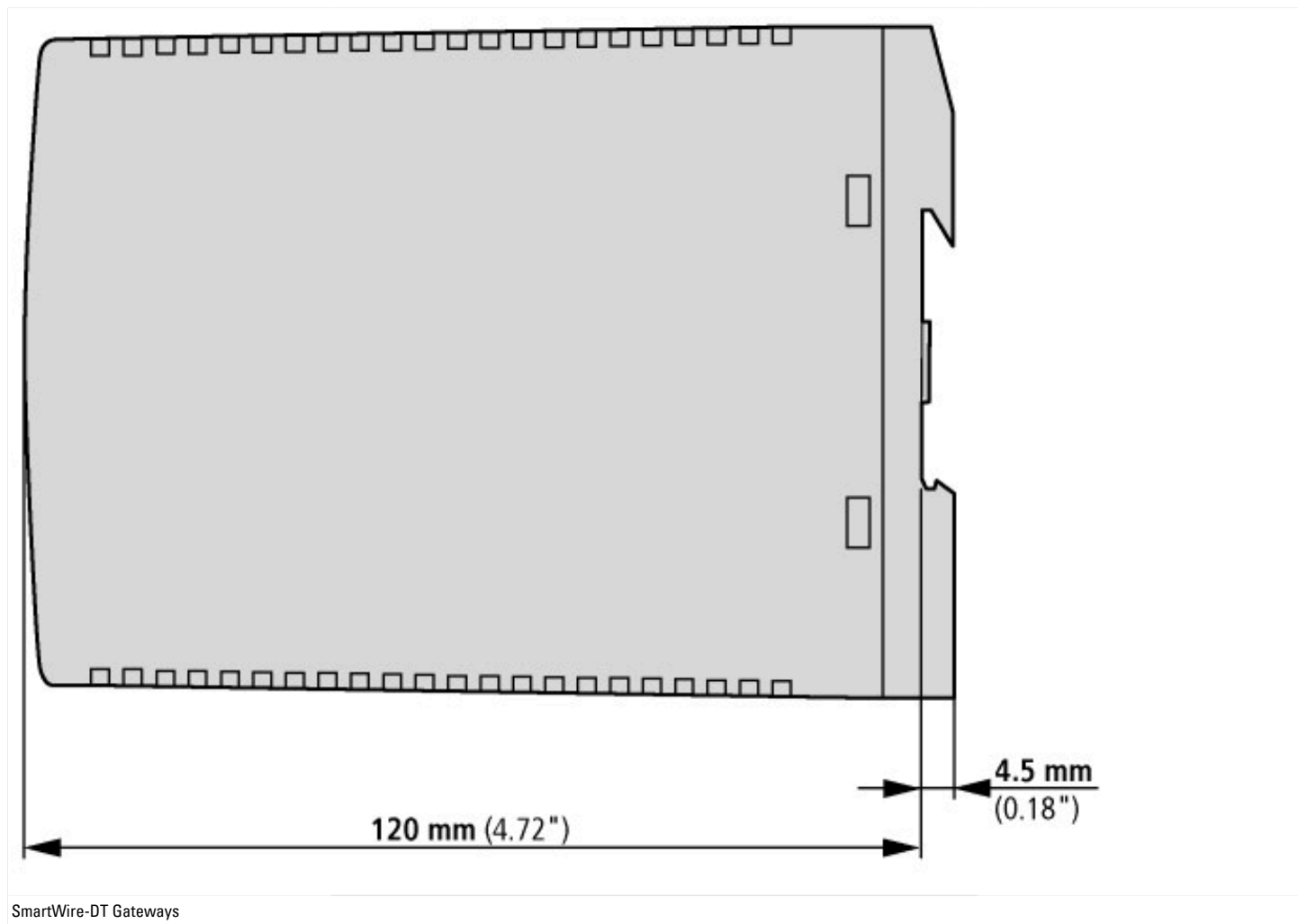

SmartWire-DT Gateways



SCATTERGOOD & JOHNSON LTD

ELECTRICAL ENGINEERING & FLUID CONTROL DISTRIBUTORS

Est.1899

At Scattergood & Johnson Ltd, we pride ourselves on being a technical distributor to specialist industries.

Working with a range of quality product suppliers across a number of specialist markets, we are not your average 'box shifter' - we are your technical and supply chain partner.

We fully support every product we sell - for free! Our internal team and external sales engineers can answer any product or application question, no matter the complexity.

Backing up this technical ability is a range of 50,000+ products available from stock for nationwide next day delivery (same day if required!), or you can collect what you need from any of our trade counters around the UK.

Select your specialist interest below to learn more about how we can help.



Online, In Branch and On the Road - Scattergood & Johnson Ltd, there when you need us.

www.scatts.co.uk