

DATASHEET - NZM1-XMV**Interlock, mechanical, size 1**

Part no. NZM1-XMV
Catalog No. 281581

**EL-Nummer
(Norway)** 4359007

**Delivery program**

Description		Allows interlocking of 2, 3 or 4 switches, including different construction sized switches, with NZM-XBZ... Bowden cables.
For use with		NZM1(-4) PN1(-4), N(S)1(-4)
Notes		
Cannot be combined with NZM...-XTV...-NA door coupling rotary handles.		
At least 2 interlock modules are required in order to assemble a mechanical interlock.		
Possible combinations and interlock versions → Engineering		
Order Bowden cable separately.		

Design verification as per IEC/EN 61439

IEC/EN 61439 design verification		
10.2 Strength of materials and parts		
10.2.2 Corrosion resistance		Meets the product standard's requirements.
10.2.3.1 Verification of thermal stability of enclosures		Meets the product standard's requirements.
10.2.3.2 Verification of resistance of insulating materials to normal heat		Meets the product standard's requirements.
10.2.3.3 Verification of resistance of insulating materials to abnormal heat and fire due to internal electric effects		Meets the product standard's requirements.
10.2.4 Resistance to ultra-violet (UV) radiation		Meets the product standard's requirements.
10.2.5 Lifting		Does not apply, since the entire switchgear needs to be evaluated.
10.2.6 Mechanical impact		Does not apply, since the entire switchgear needs to be evaluated.
10.2.7 Inscriptions		Meets the product standard's requirements.
10.3 Degree of protection of ASSEMBLIES		Does not apply, since the entire switchgear needs to be evaluated.
10.4 Clearances and creepage distances		Meets the product standard's requirements.
10.5 Protection against electric shock		Does not apply, since the entire switchgear needs to be evaluated.
10.6 Incorporation of switching devices and components		Does not apply, since the entire switchgear needs to be evaluated.
10.7 Internal electrical circuits and connections		Is the panel builder's responsibility.
10.8 Connections for external conductors		Is the panel builder's responsibility.
10.9 Insulation properties		
10.9.2 Power-frequency electric strength		Is the panel builder's responsibility.
10.9.3 Impulse withstand voltage		Is the panel builder's responsibility.
10.9.4 Testing of enclosures made of insulating material		Is the panel builder's responsibility.
10.10 Temperature rise		The panel builder is responsible for the temperature rise calculation. Eaton will provide heat dissipation data for the devices.
10.11 Short-circuit rating		Is the panel builder's responsibility. The specifications for the switchgear must be observed.
10.12 Electromagnetic compatibility		Is the panel builder's responsibility. The specifications for the switchgear must be observed.
10.13 Mechanical function		The device meets the requirements, provided the information in the instruction leaflet (IL) is observed.

Technical data ETIM 7.0

Low-voltage industrial components (EG000017) / Mechanic interlock for switch (EC001044)		
Electric engineering, automation, process control engineering / Low-voltage switch technology / Component for low-voltage switching technology / Mechanic interlock for switch (ec@ss10.0.1-27-37-13-03 [AKN341013])		
Auxiliary contacts, extendable		No
Number of contacts as normally closed contact		0
Number of contacts as normally open contact		0

Approvals

Product Standards	UL489; CSA-C22.2 No. 5-09; IEC60947, CE marking
UL File No.	E140305
UL Category Control No.	DIHS
CSA File No.	022086
CSA Class No.	1437-01
North America Certification	UL listed, CSA certified

Dimensions

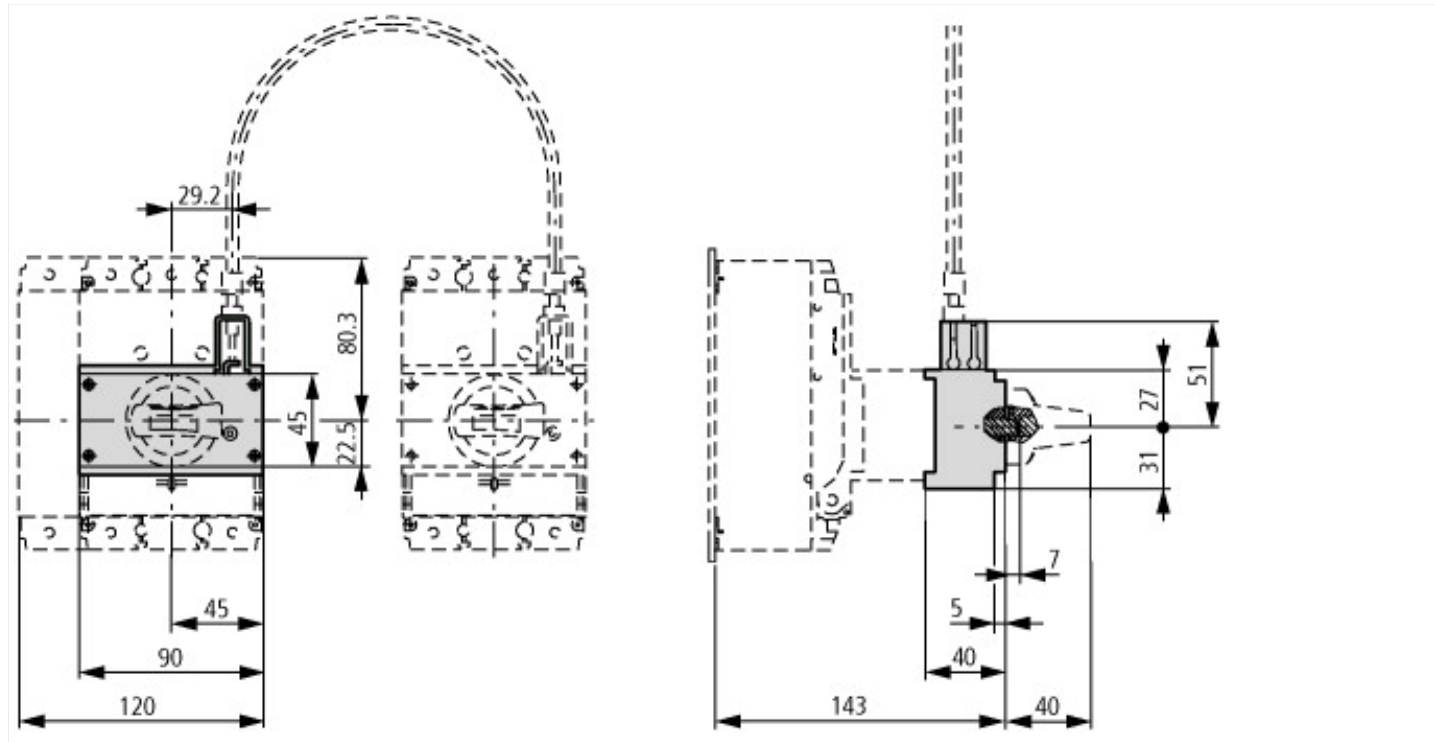

NZM1-XMV + NZM1-XDV(R)

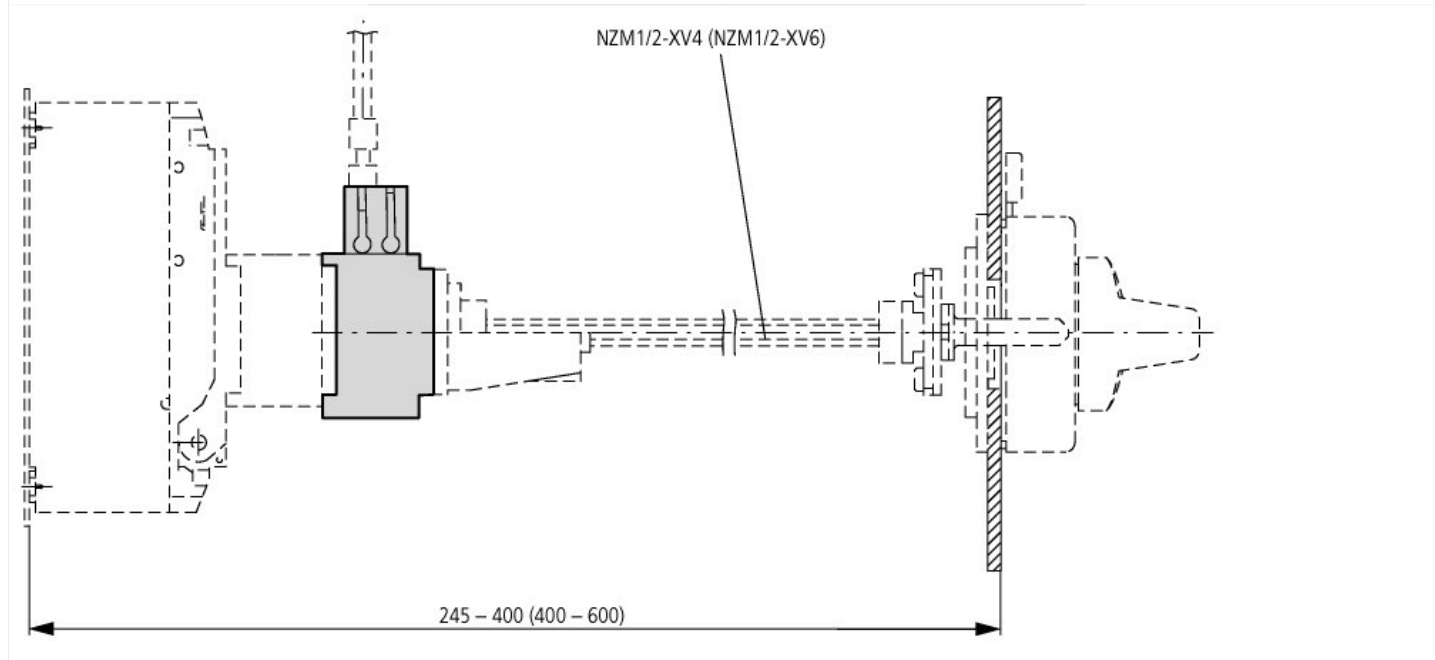

NZM1-XMV + NZM1-XTVD(V)(R)

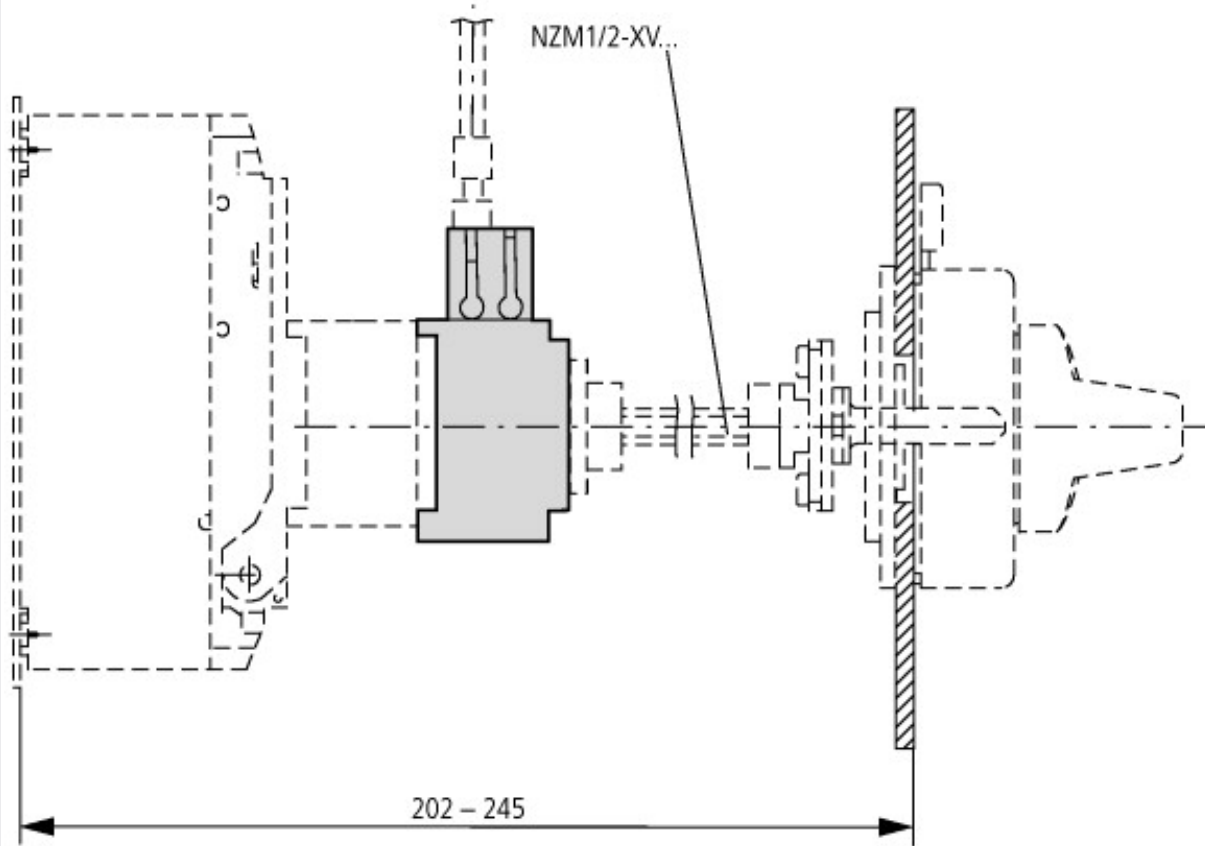

NZM1-XMV + NZM1-XTVD(V)(R)-60

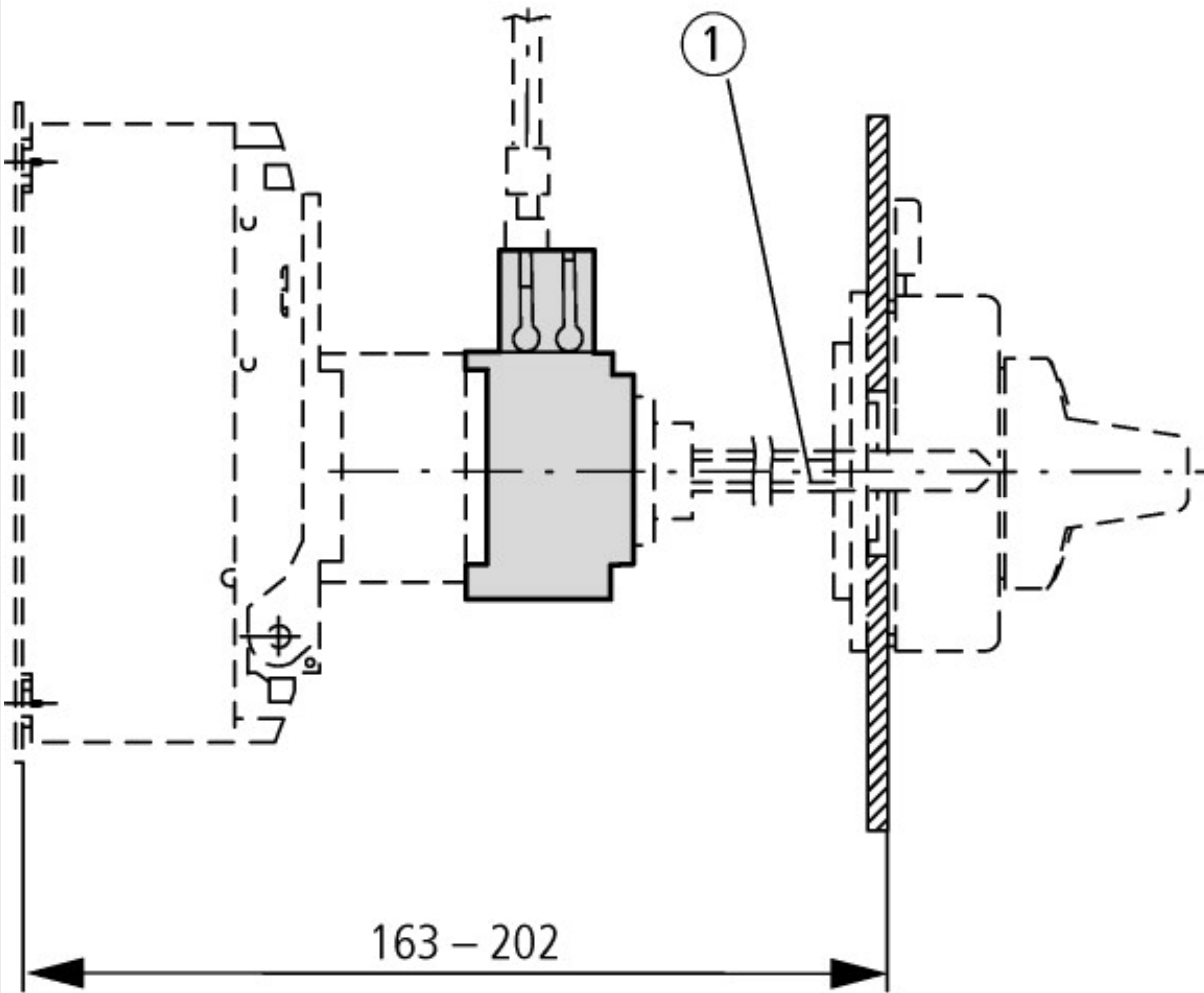

NZM1-XMV + NZM1-XTVD(V)(R)-0

① Special tip



SCATTERGOOD & JOHNSON LTD

ELECTRICAL ENGINEERING & FLUID CONTROL DISTRIBUTORS

Est.1899

At Scattergood & Johnson Ltd, we pride ourselves on being a technical distributor to specialist industries.

Working with a range of quality product suppliers across a number of specialist markets, we are not your average 'box shifter' - we are your technical and supply chain partner.

We fully support every product we sell - for free! Our internal team and external sales engineers can answer any product or application question, no matter the complexity.

Backing up this technical ability is a range of 50,000+ products available from stock for nationwide next day delivery (same day if required!), or you can collect what you need from any of our trade counters around the UK.

Select your specialist interest below to learn more about how we can help.



Online, In Branch and On the Road - Scattergood & Johnson Ltd, there when you need us.

www.scatts.co.uk