

PICCOLO PC F 65 T



Sample photo

Order symbol: PC F 65 T
Product nbr: 8724011
Description: Enclosure, PC
Remarks: Transparent cover

EAN: 6418074002181
EI. number:
 Finland: 3423513
 Electric No. Denmark: 8212001624
 Electric No. Italy: 7202040
 Electric No. Sweden: 2536850

Including: Base with screws for mounting plate, cover with PUR gasket and polyamide cover screws.

Dimensions:	Length	Width	Height	Accessories:
mm:	230	80	65	FM-3 FP 22040
inch:	9.1	3.1	2.6	DIN-35 Mounting rail Wall fastening lug (2 pcs)

Materials:	Rating:
Material: Polycarbonate	Ingress Protection (EN 60529): IP66/IP67
Base colour: RAL 7035 -light grey	Impact Resistance (EN 62262): IK08
Cover screws material: Polyamide	Electrical insulation: Totally insulated
Cover colour: Clear transparent	Halogen free (DIN/VDE 0472, Part 815): 1
Cover screws colour: Grey	UV resistance: UL 508
Gasket material: Polyurethane	Flammability Rating: UL 746C 5"
	Glow Wire Test (IEC 695-2-1) °C: 960
	NEMA Class: NEMA 1, 4X, 6, 12, 13

Temperatures:	Certificates:
Temperature °C (short term): -40 ... 120 °C	SGS Fimko
Temperature °C (continuous): -40 ... 80 °C	
Temperature °F (short term): -40 ... 250 °F	
Temperature °F (continuous): -40 ... 175 °F	

Accessories:
F-MP Mounting plate

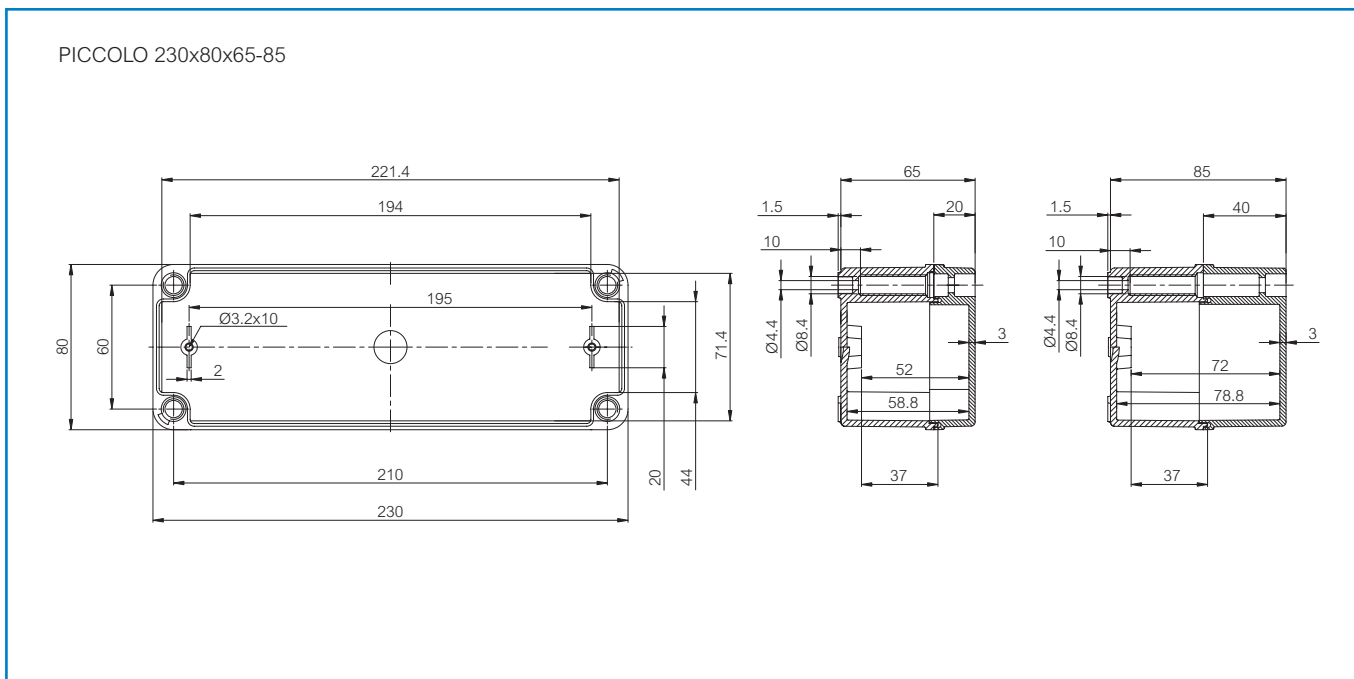



SCATTERGOOD & JOHNSON LTD

ELECTRICAL ENGINEERING & FLUID CONTROL DISTRIBUTORS

Est.1899

At Scattergood & Johnson Ltd, we pride ourselves on being a technical distributor to specialist industries.

Working with a range of quality product suppliers across a number of specialist markets, we are not your average 'box shifter' - we are your technical and supply chain partner.

We fully support every product we sell - for free! Our internal team and external sales engineers can answer any product or application question, no matter the complexity.

Backing up this technical ability is a range of 50,000+ products available from stock for nationwide next day delivery (same day if required!), or you can collect what you need from any of our trade counters around the UK.

Select your specialist interest below to learn more about how we can help.



Online, In Branch and On the Road - Scattergood & Johnson Ltd, there when you need us.

www.scatts.co.uk