

Type 6516 – 6519

3/2, 5/2 or 5/3 way solenoid valve

3/2-, 5/2- bzw. 5/3-Wege-Magnetventil

Électrovanne 3/2, 5/2 ou 5/3 voies



Operating Instructions

Bedienungsanleitung

Manuel d'utilisation

1 THE OPERATING INSTRUCTIONS

The operating instructions contain important information.

- ▶ Read the operating instructions carefully and follow the safety instructions in particular.
- ▶ The operating instructions must be available to every user.
- ▶ The liability and warranty for Type 6516 – 6519 are not applicable if the operating instructions are not followed.

1.1 Symbols

- ▶ Designates instructions for risk prevention.
- Designates a procedure which you must carry out.

Warning of serious or fatal injuries:

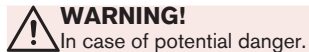
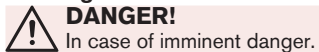

Warning of minor or moderately severe injuries:



Warning of damage:

NOTE!

1.2 Definition of the term "device"

The term "device" used in the instructions always refers to the Type 6516 – 6519.

2 INTENDED USE

Incorrect use of the solenoid valve Type 6516 – 6519 may be a hazard to people, nearby equipment and the surrounding area.

- ▶ The device is used exclusively as 3/2, 5/2 or 5/3-way solenoid valve for the media permitted according to the data sheet of the corresponding type.
- ▶ Provided the cable plug is connected and installed correctly, e.g. Bürkert Type 2506 (for Type 6516/6517) or Type 2508 (for Type 6518/6519), the device satisfies degree of protection IP65 in accordance with DIN EN 60529 / IEC 60529.
- ▶ In a hazardous area, the device may be used only in accordance with the specification on the separate Ex type label. For the use, observe the additional information enclosed with the device with safety instructions for the EX area.
- ▶ Devices without a separate Ex type label may not be used in a potentially explosive area.
- ▶ Use according to the authorized data, operating conditions and conditions of use specified in the contract documents, the data sheet and the operating instructions.
- ▶ Correct transport, correct storage and installation as well as careful use and maintenance are essential for reliable and problem-free operation.
- ▶ Use the device only for its intended purpose.

3 BASIC SAFETY INSTRUCTIONS

These safety instructions do not make allowance for any contingencies and events which may arise during assembly, operation and maintenance.



Danger – high pressure!

- ▶ Turn off the pressure and vent the lines before loosening lines or valves.

Risk of electric shock!

- ▶ Before reaching into the device or the equipment, switch off the power supply and secure to prevent reactivation!
- ▶ Observe applicable accident prevention and safety regulations for electrical equipment!

Risk of injury from greatly accelerated device parts!

- ▶ Before pressurizing the valve, check that all screw connections and screw joints are tight and secure.

Risk of burns/danger of fire during long-term operation due to hot device surface!

- ▶ Keep the device away from highly flammable substances and media and do not touch with bare hands.

Risk of injury due to malfunction of valves with alternating current (AC)!

Sticking core causes coil to overheat, resulting in a malfunction.

- ▶ Monitor process to ensure flawless functioning.

To prevent injuries/damage:

- ▶ Never adjust the screws which are locked with red paint.
- ▶ Do not make any internal or external changes to the device and safeguard against unintentional actuation.
- ▶ Installation and maintenance work may be carried out only by authorized technicians with the appropriate tools.
- ▶ After an interruption in the electrical or pneumatic supply, ensure that the process is restarted in a defined or controlled manner.
- ▶ Do not subject the housing to mechanical loads.
- ▶ Observe the general accepted technical rules.

3.1 Restrictions

If exporting the device, observe any existing restrictions.

4 STRUCTURE AND FUNCTION

The valves can be mounted in blocks on the modular pneumatic base rail Type MP07.

4.1 Structure of the standard designs

4.1.1 Connections

All connections are identified by numbers on the valve surface. These refer to the following functions:

| Number | Function |
|-----------|-----------------------|
| 1 | Pressure inlet port |
| 2 and 4 | Outlet port |
| 3 and 5 | Exhaust port |
| 12 and 14 | Control pressure port |

4.1.2 Type 6516 (3/2-way), Type 6517 (5/2-way)

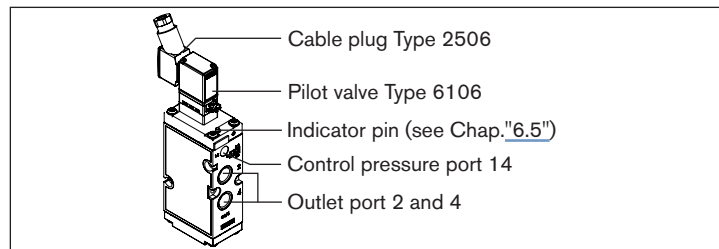

Fig. 1: Valve structure Type 6516/6517 (in the example Type 6517)

4.1.3 Type 6518 (3/2-way), Type 6519 (5/2-way)

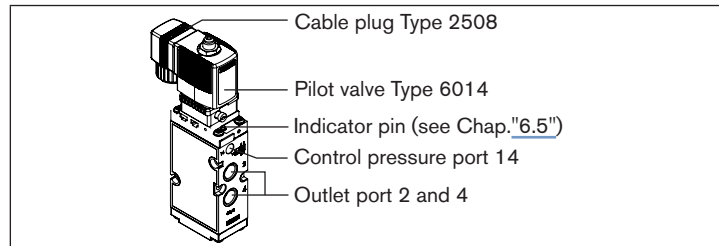

Fig. 2: Valve structure Type 6518/6519 (in the example Type 6519)

4.1.4 5/3-way function, 5/2-way function impulse

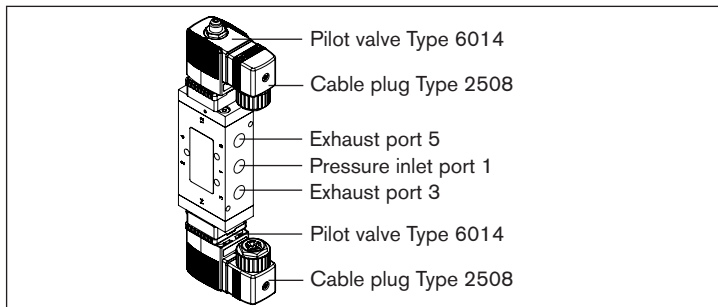

Fig. 3: Valve structure 5/3-way function, 5/2-way function impulse

4.1.5 Type 6517 and 6519 with plastic body and NAMUR flange with adapter plate

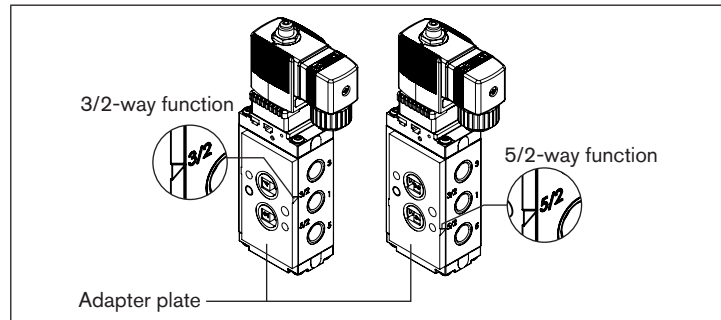
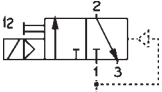
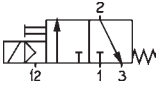
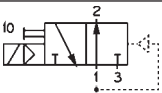
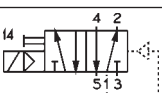
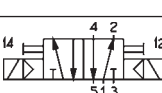

Fig. 4: Valve structure NAMUR in the example Type 6519

The valves Type 6517 and 6519 Namur with plug tabs at the side are supplied ex works, 5/2-way function. The 3/2 way function is set by turning the adapter plate 180°.

When using as 3/2-way valve, close port 3 with supplied sealing plug G1/4. When using on large actuators with fast outlet time, use a silencer instead of the sealing plug.

4.2 Operating principles

| | |
|---|---|
| <p>C</p>  | <p>3/2-way valve Normally inlet port 1 (P/NC) closed, outlet port 2 (A/OUT) connected with exhaust port 3 (R/NO).</p> |
| <p>(MP07) C</p>  | <p>3/2-way valve for vacuum*, with auxiliary control air Normally inlet port 1 (P/NC) closed, outlet port 2 (A/OUT) connected with exhaust port 3 (R/NO).</p> |
| <p>D</p>  | <p>3/2-way valve Normally inlet port 1 (P/NO) connected with outlet port 2 (B/OUT), exhaust port 3 (R/NC) closed.</p> |
| <p>H</p>  | <p>5/2-way valve Normally inlet port 1 (P) connected with outlet port 2 (A), outlet port 4 (B) connected with exhaust port 5 (S), exhaust port 3 (R) closed.</p> |
| <p>Z</p>  | <p>5/2-way valve Pulse version (2 coils)</p> |

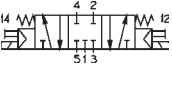
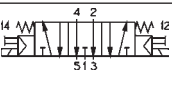
| | |
|--|---|
| <p>L</p>  | <p>5/3-way valve Middle position all port connections closed, inlet port 1, outlet port 4 and 2, vent of outlet ports to 5 respectively 3.</p> |
| <p>N</p>  | <p>5/3-way valve Middle position pressure inlet port 1 (P) closed, outlet ports 2 (A) and 4 (B) connected with exhaust ports 3 (R) respectively 5 (S).</p> |



* The vacuum generator must be connected to port 1.

5 TECHNICAL DATA

5.1 Conformity

The solenoid valve Type 6516 – 6519 is compliant with EC directives as stated in the EC Declaration of Conformity.

5.2 Standards

The applied standards which are used to demonstrate compliance with the EC Directives are listed in the EC Prototype Examination Certificate and/or the EC Declaration of Conformity.

5.3 Type label

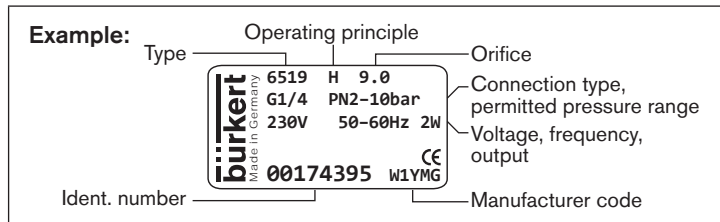

Fig. 5: Example of type label on the pilot-controlled solenoid valve Type 6519

5.4 Operating conditions



Please observe the specifications on the data sheet and on the type label.

| | Types 6516 – 6519 | Type 6519 for extended temperature range |
|-----------------------------------|--|--|
| Ambient temperature ¹⁾ | -25 °C ... +55 °C | Aluminum ematalized: -40 ... + 80 °C Stainless steel: -30 ... + 80 °C |
| Permitted medium temp. | -10 ... +50 °C | -30 ... +80 °C |
| Compressed air quality | ISO 8573-1:2010, Class 7.4.4 ²⁾ | ISO 8573-1:2010, Class 7.2.4 ²⁾ |
| Permitted pressure range | Observe specifications on type label Pressure difference at least 2 bar between ports 1 and 3/5 | |

| | Types 6516 – 6519 | Type 6519 for extended temperature range |
|----------------------|--|--|
| Degree of protection | IP65 as per DIN EN 60529 / IEC 60529 with correctly connected and fitted cable plug, e.g. Bürkert Type 2506 (Type 6516/6517) or Type 2508 (Type 6518/6519) | |
| Permitted media | Filtered compressed air oiled and unoled, neutral gases | |
| Operating duration | Unless otherwise indicated on the type label, the solenoid system is suitable for continuous operation | |

The following values must also be observed for valves with UL/UR approval:

| Valve types | Fluid temperature | Ambient temperature | Fluid |
|-------------|-------------------|---------------------|-------|
| 6518 | -10 °C...+55 °C | -10 °C...+55 °C | Air |
| 6519 | | | |

- 1) *Observe temperature restrictions on account of approvals.*
- 2) *To prevent the expanded compressed air from freezing, its pressure dew point **must** be **at least 10 K lower than the medium temperature.***



Important information for functional reliability during continuous operation!

If the equipment is switched off for a long period, it is recommended to activate the valves at least 1-2 per day.

Service life:

High switching frequency and high pressures reduce the service life. The valves operate maintenance-free.

5.5 Materials

The seal materials depend on the housing materials:

| Housing material | PA | AL anodized | AL ematalized | VA |
|------------------|----------|-------------|---------------|--------------|
| Seal material | NBR, PUR | NBR | FKM, NBR | PU, NBR, FKM |

5.6 External control pressure

If valves are designed for auxiliary control air, the compressed air supply must be connected to port 12 or 14 (control pressure port).

Control pressure: at least 70% of the operating pressure to port 1 (minimum control pressure 2.5 bar)

6 ASSEMBLY

6.1 Safety instructions



DANGER!

Risk of injury from high pressure in the system!

- ▶ Turn off the pressure and vent the lines before loosening lines or valves.

Risk of injury due to electrical shock!

- ▶ Before reaching into the device or the equipment, switch off the power supply and secure to prevent reactivation!
- ▶ Observe applicable accident prevention and safety regulations for electrical equipment!



WARNING!

Risk of injury from greatly accelerated device parts and unconnected whiplashing compressed air hoses!

- ▶ Before pressurizing the valve, check that all screw connections and screw joints are tight and secure.

Risk of injury from improper assembly!

- ▶ Assembly may only be carried out by authorized technicians and with the appropriate tools!

Risk of injury from unintentional activation of the system and uncontrolled restart!

- ▶ Secure system against unintentional activation.
- ▶ Following assembly, ensure a controlled restart.

6.2 Installation of the pilot valve



WARNING!

Risk of injury from leaking valve.

- ▶ Ensure that the O-rings/seals are correctly seated in the valve.

Overheating, risk of fire!

Connection of the coil without pre-assembled valve will result in overheating and destroy the coil.

- ▶ Connect the coil with pre-assembled valve only.

Danger due to electrical shock if coil incorrectly installed!

- ▶ During installation ensure that the coil is situated firmly on the housing cover so that the protective conductor connection of the coil is connected to the valve housing.

NOTE!

Caution risk of breakage!

- Do not use coil as a lever arm.

6.2.1 Installation of the pilot valve Type 6106 (for valve type 6516/6517)

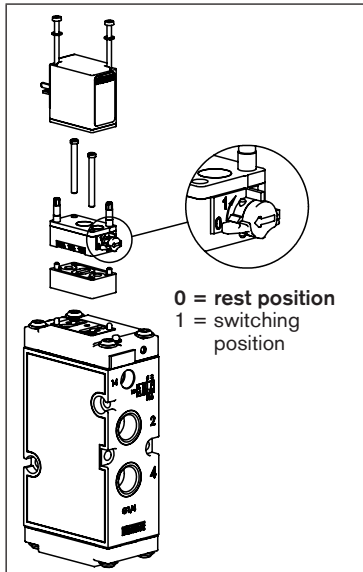

- Installation always in the position shown; if required, turn coil by 180°.
- Screw the housing of the pilot valve to the housing of the main valve using 2 screws. Observe tightening torque of max. 0.5 Nm.
- Mount solenoid coil and screw down using M2 screws. Observe tightening torque of max. 0.15 Nm.

6.2.2 Installation of the pilot valve Type 6014 (for valve type 6518/6519)

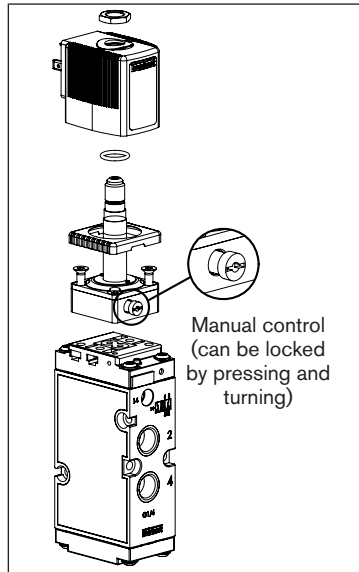

- Screw the housing of the pilot valve to the main valve. Observe tightening torque of max. 1.5 Nm.
- Connect the coil to the core guide tube. The coil can be turned by 4 x 90° (for block assembly only 2 x 180°).
- Screw down the coil with a nut **using an open-end wrench** (the device may be damaged if other tools are used, e.g. pliers). Observe tightening torque of max. 5 Nm.

6.3 Pneumatic connection



WARNING!

Risk of injury from greatly accelerated device parts and unconnected whiplashing compressed air hoses!

- ▶ Before pressurizing the valve, check that all screw connections and screw joints are tight and secure.

Installation position: any, preferably with solenoid system face up.

Before connecting:

- Check whether hose lines are dirty and clean.
- If required, install a dirt filter upstream of the valve inlet ($\leq 500 \mu\text{m}$).

Pneumatic connection:

- Hold the device by hand **on the housing** and connect to the hose line. Do not exceed the standard screw-in depth.
- Seal with PTFE tape or elastomer seal.
- Observe allocation of the connections (see Chapter ["4.1.1 Connections"](#), page 4).
- Align hose lines.

6.4 Connection of cable plug to the power supply



WARNING

Risk of injury due to electrical shock!

- ▶ Before reaching into the system, switch off the electrical power supply and secure to prevent reactivation!
- ▶ Observe applicable accident prevention and safety regulations for electrical equipment!

If the protective conductor contact between the coil and housing is missing, there is a danger of electric shock!

- ▶ Always connect protective conductor.
- ▶ Check electrical continuity between coil and housing.

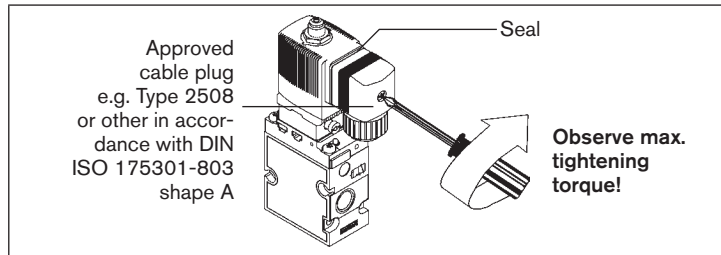

- Tighten cable plug (for authorized types see data sheet), observing maximum torque (see "[Tab. 1](#)").
- Check that seal is fitted correctly.
- Connect protective conductor and check electrical continuity between coil and housing (see "[Tab. 2](#)").

NOTE!

If the cable plug EN 175-301-803 is designed in such a way that the screw is pointing upwards, insert a seal made of a material compatible with your process under the screw head.



Note the voltage and current type as specified on the type label.

| | | |
|------------------------------------|------------------|------------------|
| Valve type | 6516/6517 | 6518/6519 |
| Cable plug Type | 2506 | 2508 |
| Tightening torque max. (Nm) | 0.3 | 1 |

Tab. 1: Maximum tightening torque of cable plug

| Pesistor | Test voltage | Test current |
|-------------------------------------|---------------------|---------------------|
| max. 0.1 Ω | 12 V | 1 A |

Tab. 2: Test values protective conductor function

6.5 Pneumatic position indicator

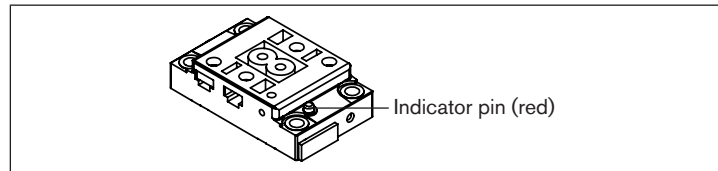

Fig. 6: Pneumatic position indicator

When the valve is switched off, the red indicator pin can be pressed in without any resistance. When the valve is actuated, the indicator pin moves out and there is perceptible resistance to pressing it in.

NOTE!

Whenever performing a function test, press in the indicator pin again.

7 DISASSEMBLY

Disassembly is in reverse sequence to assembly.

8 MAINTENANCE, TROUBLESHOOTING

If the valve is used according to these operating instructions, the valve will operate maintenance-free.

8.1 Safety instructions



WARNING!

Risk of injury from improper maintenance!

- ▶ Maintenance may only be carried out by authorized technicians and with the appropriate tools!

Risk of injury due to electrical shock!

- ▶ Before reaching into the device or the equipment, switch off the power supply and secure to prevent reactivation!

Danger – high pressure!

- ▶ Turn off the pressure and vent the lines before loosening lines or valves.

Risk of injury from unintentional activation of the system and uncontrolled restart!

- ▶ Secure system against unintentional activation.
- ▶ Following maintenance, ensure a controlled restart.

8.2 Malfunctions

If malfunctions occur, check whether:

- the device has been installed according to the instructions,
- the electrical and pneumatic connections are correct,
- the device is not damaged,
- all screws have been tightened,
- the voltage and pressure have been switched on,
- the pipelines are clean.

Valve does not switch

Possible causes:

- short circuit or coil interrupted,
- core or core area dirty,
- medium pressure outside the permitted pressure range.

Valve does not close

Possible causes:

- inner compartment of the valve is dirty.

9 SPARE PARTS



CAUTION!

Risk of injury and/or damage by the use of incorrect parts!

Incorrect accessories and unsuitable spare parts may cause injuries and damage the device and the surrounding area.

- ▶ Use original accessories and original spare parts from Bürkert only.

9.1 Ordering spare parts

When ordering spare parts, quote the number of the spare part set (SET 1, SET 2, SET 3 – see ["Fig. 7: Spare part sets", page 15](#)) as well as the order number of your complete device.

9.2 Overview of spare part sets

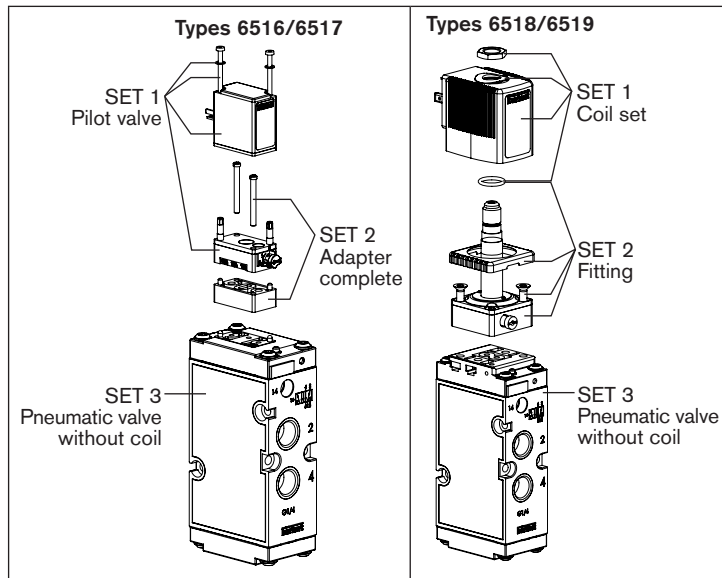

Fig. 7: Spare part sets

10 TRANSPORTATION, STORAGE, DISPOSAL

NOTE!

Transport damage!

Inadequately protected devices may be damaged during transportation.

- ▶ Protect the device against moisture and dirt in shock-resistant packaging during transportation.
- ▶ Prevent the temperature from exceeding or dropping below the permitted storage temperature.
- ▶ Protect the electrical interfaces of the coil and the pneumatic connections from damage by placing protective caps on them.

Incorrect storage may damage the device.

- ▶ Store the device in a dry and dust-free location!
- ▶ Storage temperature $-40\text{ °C} \dots +80\text{ °C}$.

Damage to the environment caused by device components contaminated with media.

- ▶ Dispose of the device and packaging in an environmentally friendly manner!
- ▶ Observe applicable disposal and environmental regulations.

Bürkert Fluid Control Systems
Sales Center
Christian-Bürkert-Str. 13-17
D-74653 Ingelfingen
Tel. + 49 (0) 7940 - 10 91 111
Fax + 49 (0) 7940 - 10 91 448
E-mail: info@de.buerkert.com

International address

www.burkert.com

Manuals and data sheets on the Internet: www.burkert.com
Bedienungsanleitungen und Datenblätter im Internet: www.buerkert.de
Manuels et fiches techniques sur Internet : www.buerkert.fr

© Bürkert Werke GmbH & Co. KG, 2011 - 2017
Operating Instructions 1701 / F1_ÖWEP_00803G I / Original DE

www.burkert.com



SCATTERGOOD & JOHNSON LTD

ELECTRICAL ENGINEERING & FLUID CONTROL DISTRIBUTORS

Est.1899

At Scattergood & Johnson Ltd, we pride ourselves on being a technical distributor to specialist industries.

Working with a range of quality product suppliers across a number of specialist markets, we are not your average 'box shifter' - we are your technical and supply chain partner.

We fully support every product we sell - for free! Our internal team and external sales engineers can answer any product or application question, no matter the complexity.

Backing up this technical ability is a range of 50,000+ products available from stock for nationwide next day delivery (same day if required!), or you can collect what you need from any of our trade counters around the UK.

Select your specialist interest below to learn more about how we can help.



Online, In Branch and On the Road - Scattergood & Johnson Ltd, there when you need us.

www.scatts.co.uk