

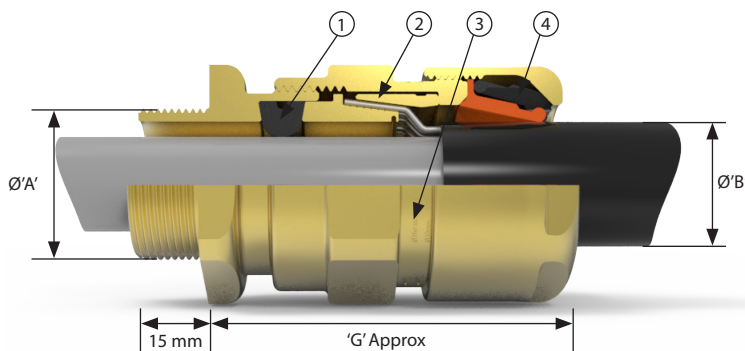

153/RAC

Industrial gland for indoor or outdoor use



- 1 Elastomeric seal on cable inner sheath
- 2 Fully Inspectable Armour Clamp
- 3 Patented Cable Gland Tightening Guide - Helps prevent damage caused by over tightening
- 4 Unique Rear Seal - Offering ultimate sealing over an extremely wide cable acceptance range.

The 153/RAC Cable Gland is an industrial gland for indoor or outdoor use, robust and for use with single wire armour 'W', wire braid 'X', steel tape armour 'Z', elastomer and plastic insulated cables. The gland provides an elastomeric seal on the cable inner sheath, and a low smoke, zero halogen IP and retention seal onto the cable outer sheath.

Cable Gland Selection Table

Size Ref.	Entry Thread Size 'A'		Cable Acceptance Details							'G'	Hexagon Dimensions		
	Metric	NPT* Standard	Inner Sheath				Outer Sheath 'B'		Armour Braid 'C'		Across Flats	Across Corners	
			Std Seal	Alt Seal (S)	Min	Max	Orientation 1	Orientation 2					
Os	M20 ²	½"	3.2	8	-	-	5.5	12.0	0.8/1.25	0.0/0.8	52.0	24.0	26.5
O	M20 ²	½"	6.5	11.9	-	-	9.5	16.0	0.8/1.25	0.0/0.8	52.0	24.0	26.5
A	M20	¾" or ½"	10	14.3	9	14.3	12.5	20.5	0.8/1.25	0.0/0.8	53.0	30.0	32.5
B	M25	1" or ¾"	13	20.2	9.5	15.4	16.9	26.0	1.25/1.6	0.0/0.7	69.5	36.0	39.5
C	M32	1¼" or 1"	19.5	26.5	15.5	21.2	22.0	33.0	1.6/2.0	0.0/0.7	64.0	46.0	50.5
C2	M40	1½" or 1¼"	25	32.5	22	28	28.0	41.0	1.6/2.0	0.0/0.7	68.3	55.0	60.6
D	M50	2" or 1½"	31.5	44.4/42.3 ¹	27.5	34.8	36.0	52.6	1.8/2.5	0.0/1.0	79.0	65.0	70.8
E	M63	2½" or 2"	42.5	56.3/54.3 ¹	39	46.5	46.0	65.3	1.8/2.5	0.0/1.0	78.9	80.0	88.0
F	M75	3" or 2½"	54.5	68.2/65.3 ¹	49.5	58.3	57.0	78.0	1.8/2.5	0.0/1.0	83.7	95.0	104.0
G	M80	3½"	67	73	-	-	75.0	89.5	2.0/3.5	0.0/1.0	95.6	106.4	115.0
H	M90	3½"	67	77.6	-	-	75.0	89.5	2.0/3.5	0.0/1.0	95.6	115.0	130.0
J	M100	4"	77	91.6	-	-	88.0	104.5	2.5/4.0	0.0/1.0	95.6	127.0	142.0

All dimensions in millimetres (except * where dimensions are in inches).

Os - F size metric entry threads are 1.5mm pitch as standard, 15mm length of thread. G - J size metric entry threads are 2mm pitch as standard, 20mm length of thread

¹ Smaller value is applicable when selecting reduced NPT entry option.

² Sizes Os and O are available with an M16 thread size. For O size with M16 thread, the maximum cable outer sheath diameter is 10.9mm

Technical Data

Construction & Test Standards	BS EN 62444:2013, BS 6121: Part 1 Type E1W, E1X, E1Y and E1Z
Ingress Protection	IP66, IP67 and IP68 (30 metres for 7 days) to IEC/EN 60529 and NEMA 4X
Deluge Protection	DTS01
Operating Temperature	-60°C to +80°C

Alternative Reversible Armour Clamping Ring Size Selection

Size Ref	Orientation 1	Orientation 2
B	0.9 - 1.25	0.5 - 0.9
C	1.2 - 1.6	0.6 - 1.2
C2	1.2 - 1.6	0.6 - 1.2
D	1.45 - 1.8	1.0 - 1.45
E	1.45 - 1.8	1.0 - 1.45
F	1.45 - 1.8	1.0 - 1.45

Ordering Information

Format for ordering is as follows: Alternative Seal (S), Alternative Clamping Ring (AR), add suffix S and/or AR to ordering information

Cable Gland Type	Size	Thread	Material	(Optional)
153/RAC	C	M32	Brass	AR
153/RAC	C	1¼" NPT	Brass	S

Order Example: 153/RAC C M32 BRASS AR

Cable Gland Tightening Guide

Whilst Hawke International goes to great lengths to ensure products are designed to be as simple to install, inspect and maintain as is possible, differing levels of competency, training and understanding can lead to glands being incorrectly installed. With hazardous area products, any poor installation issues can not only lead to expensive equipment failure, but also potential explosion risks and associated risk to life.

To help address issues with the overtightening of cable glands and the resultant damage to cables and seals, Hawke International has developed the patented **INBUILT TIGHTENING GUIDE**.

Without the need for fiddly measuring systems, the guide provides a permanent visual indication of the gland tightness through installation, inspection and maintenance.

How it works

The gland is permanently marked with various lines/numbers indicating the correct tightening level related to the cable diameter. Following the relevant cable gland Installation Instructions, the back seal should be tightened until a seal is formed on the cable outer sheath and then tightened one further turn.



Follow cable gland installation instructions until final stage – tightening of rear seal



Tighten backnut until a seal is formed onto the cable, then tighten one further turn



The backnut should be level with the marking guide corresponding to its diameter – this can be visually inspected and adjusted as necessary

Note: The cable gland installation instructions have a printed cable OD measure for if the cable OD is not known



SCATTERGOOD & JOHNSON LTD

ELECTRICAL ENGINEERING & FLUID CONTROL DISTRIBUTORS

Est.1899

At Scattergood & Johnson Ltd, we pride ourselves on being a technical distributor to specialist industries.

Working with a range of quality product suppliers across a number of specialist markets, we are not your average 'box shifter' - we are your technical and supply chain partner.

We fully support every product we sell - for free! Our internal team and external sales engineers can answer any product or application question, no matter the complexity.

Backing up this technical ability is a range of 50,000+ products available from stock for nationwide next day delivery (same day if required!), or you can collect what you need from any of our trade counters around the UK.

Select your specialist interest below to learn more about how we can help.



Online, In Branch and On the Road - Scattergood & Johnson Ltd, there when you need us.

www.scatts.co.uk