

ELECTRONIC HYGROSTAT

EFR 012



- > Adjustable and pre-set relative humidity
- > Status indicator (LED)
- > High switching capacity
- > Clip fixing
- > Temperature-compensated

The electronic hygrostat senses the relative humidity in an enclosure with electric/electronic components and turns on a heater at the set point, helping prevent the formation of condensation in the enclosure. The LED integrated in the adjustment knob is lit when the connected heater is in operation.



TECHNICAL DATA

Switch difference	5 % RH (± 3 % RH tolerance) at +25 °C (+77 °F), 50 % RH
Reaction time	5 sec.
Contact type	change-over contact (relay)
Service life	> 50,000 cycles
Max. switching capacity (relay output)	AC 240 V / AC 120 V 8 (1.6) A DC 100 W at DC 24 V
Max. inrush current	AC 16 A for 10 sec.
Optical indicator	LED
Connection	5-pole terminal, clamping torque 0.5 Nm max.: rigid/stranded ¹ wire 2.5 mm ² (AWG 14)
Mounting	clip for 35 mm DIN rail, EN 60715
Casing	plastic according to UL94 V-0, light grey
Dimensions	64.5 x 42 x 38 mm
Weight	approx. 70 g
Fitting position	vertical
Operating/Storage temperature	0 to +60 °C (+32 to +140 °F) / -20 to +70 °C (-4 to +158 °F)
Operating/Storage humidity	max. 90 % RH (non-condensing)
Protection type	IP20

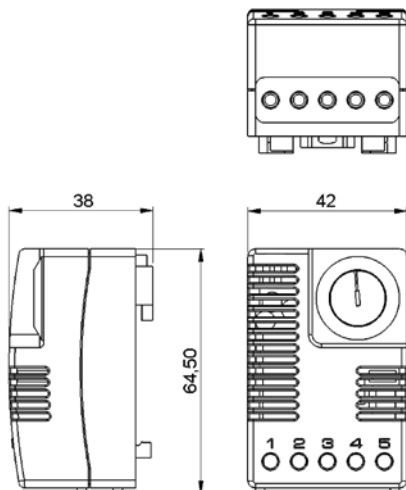

¹ When connecting with stranded wires, wire end ferrules must be used.

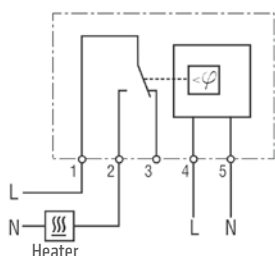

Connection diagram

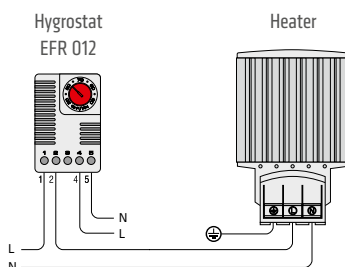

Example of connection

Art. No.	Operating voltage	Setting range	Approvals		
01245.0-00	AC 230 V, 50/60 Hz	40 to 90 % RH	VDE	UL File No. E164102	EAC
01246.0-00	AC 230 V, 50/60 Hz	65 % RH pre-set	VDE	UL File No. E164102	EAC
01246.0-01	AC 230 V, 50/60 Hz	50 % RH pre-set	VDE	UL File No. E164102	EAC
01245.9-00	AC 120 V, 50/60 Hz	40 to 90 % RH	-	UL File No. E164102	EAC
01246.9-00	AC 120 V, 50/60 Hz	65 % RH pre-set	-	UL File No. E164102	EAC



SCATTERGOOD & JOHNSON LTD

ELECTRICAL ENGINEERING & FLUID CONTROL DISTRIBUTORS

Est.1899

At Scattergood & Johnson Ltd, we pride ourselves on being a technical distributor to specialist industries.

Working with a range of quality product suppliers across a number of specialist markets, we are not your average 'box shifter' - we are your technical and supply chain partner.

We fully support every product we sell - for free! Our internal team and external sales engineers can answer any product or application question, no matter the complexity.

Backing up this technical ability is a range of 50,000+ products available from stock for nationwide next day delivery (same day if required!), or you can collect what you need from any of our trade counters around the UK.

Select your specialist interest below to learn more about how we can help.



Online, In Branch and On the Road - Scattergood & Johnson Ltd, there when you need us.

www.scatts.co.uk