

ELECTRONIC HYGROTHERM

ETF 012



- > Temperature and humidity adjustable
- > Wide voltage range
- > Operating temperature down to -40 °C
- > High switching capacity
- > Status indicator (LED)

The electronic hygrotherm senses the ambient temperature and relative humidity in an enclosure with electric/electronic components and turns on a heater (or alternatively a fan) at either set point, helping prevent the formation of condensation in the enclosure. Due to its wide voltage range the hygrotherm can be utilised anywhere in the world. The LED integrated in the adjustment knob on the active controller is lit when the connected device is in operation.



TECHNICAL DATA

Switch difference (temperature)	2 K (± 1 K tolerance) at +25 °C (+77 °F), 50 % RH
Switch difference (humidity)	4 % RH (± 1 % tolerance) at +25 °C (+77 °F), 50 % RH
Reaction time (humidity)	approx. 5 sec.
Contact type	change-over contact (relay)
Service life	VDE: NO/NC > 15,000 cycles UL: NO/NC > 30,000 cycles
Max. switching capacity (relay output)	AC 240 V, 10 (1.6) A DC 60 V, 0.6 A ¹
Max. inrush current	AC 30 A for 10 sec.
Optical indicator	LED
Connection	5-pole terminal, clamping torque 0.5 Nm max.: rigid/stranded ² wire 2.5 mm ² (AWG 14)
Mounting	clip for 35mm DIN rail, EN 60715
Casing	plastic according to UL94 V-0, light grey
Dimensions	77 x 60 x 43 mm
Weight	approx. 0.2 kg
Fitting position	vertical
Operating/Storage temperature	-40 to +60 °C (-40 to +140 °F)
Operating/Storage humidity	max. 90 % RH (non-condensing)
Protection type	IP20
Approvals	VDE, UL File No. E164102, EAC

¹ not UL confirmed

² When connecting with stranded wires, wire end ferrules must be used.

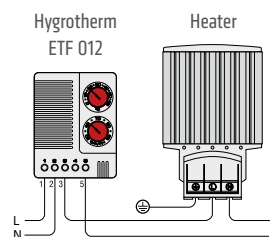
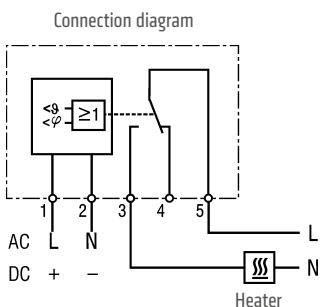
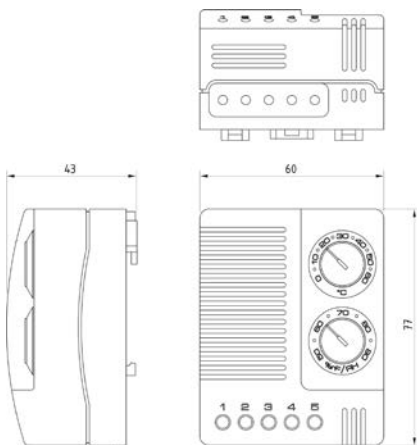

Example of connection

Art. No.	Operating voltage	Setting range temperature	Setting range humidity
01230.0-00	AC 100 – 240 V, 50/60 Hz (min. AC 90 V, max. AC 265 V)	0 to +60 °C	50 to 90 % RH
01230.9-00	AC 100 – 240 V, 50/60 Hz (min. AC 90 V, max. AC 265 V)	+32 to +140 °F	50 to 90 % RH
01230.1-00	DC 24 – 48 V (min. DC 20 V, max. DC 60 V)	0 to +60 °C	50 to 90 % RH



SCATTERGOOD & JOHNSON LTD

ELECTRICAL ENGINEERING & FLUID CONTROL DISTRIBUTORS

Est.1899

At Scattergood & Johnson Ltd, we pride ourselves on being a technical distributor to specialist industries.

Working with a range of quality product suppliers across a number of specialist markets, we are not your average 'box shifter' - we are your technical and supply chain partner.

We fully support every product we sell - for free! Our internal team and external sales engineers can answer any product or application question, no matter the complexity.

Backing up this technical ability is a range of 50,000+ products available from stock for nationwide next day delivery (same day if required!), or you can collect what you need from any of our trade counters around the UK.

Select your specialist interest below to learn more about how we can help.



Online, In Branch and On the Road - Scattergood & Johnson Ltd, there when you need us.

www.scatts.co.uk