

A-GSM

(DATASHEET)

Type	LTE Antenna
Frequencies	AMPS (824-894 MHz) GSM (900 MHz) DCS (1800 MHz) PCS (1900 MHz) 3G (UMTS 2.1 GHz) WIFI / BLUETOOTH (2.4 GHz) 4G/LTE (699-960/1710-2690 MHz)
Mounting	Glass Mount
Revision	00



1. PRODUCT SELECTION

A-GSM Multiband antenna, black version

2. SPECIFICATION

2.1. *Electrical Specifications*

Frequencies	AMPS (824-894 MHz) GSM (900 MHz) DCS (1800 MHz) PCS (1900 MHz) 3G (UMTS 2.1 GHz) WIFI / BLUETOOTH (2.4 GHz) 4G/LTE (699-960/1710-2690 MHz)
Impedance	50 Ohms
Polarization	Linear
Gain	2.14dBi
VSWR	Full 4G/LTE <5:1 / Europe: <2:1
Power handling	25W
Operating temperature	-40°C to +85°C

2.2. *Connection Specifications*

Connector type: SMA male
 Cable: RG174U
 Cable length: 3 m

2.3. *Mechanical Specifications and Dimensions*

Material: PVC
 Max. dimensions: 6.7mm x 117.4mm x 12.5mm (H x L x W)
 Weight: ~16 g weight without 300 cm cable length and SMA connector
 Colour: Black

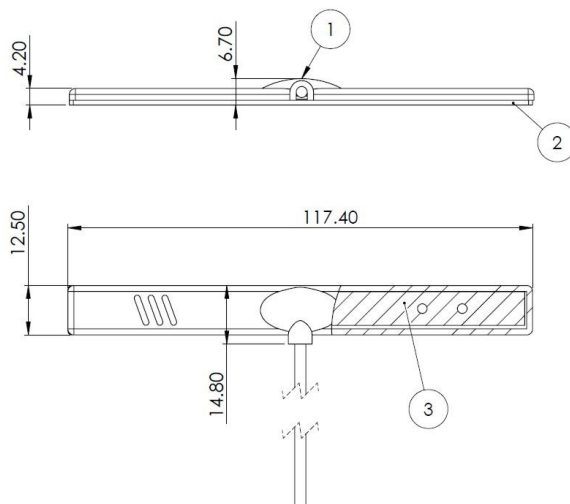

3. MEASUREMENT

3.1. S11

Log Mag (Quad Band)

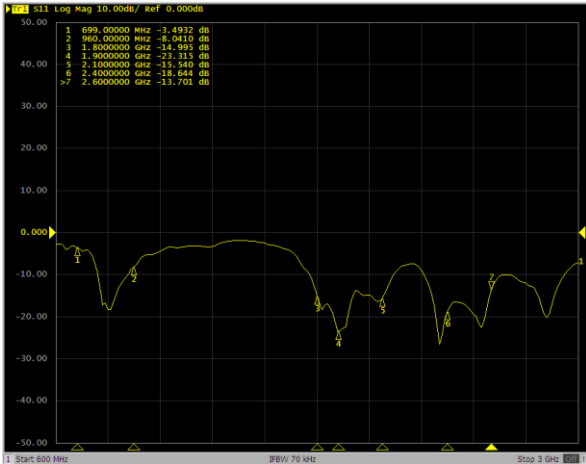

VSWR (Quad Band)

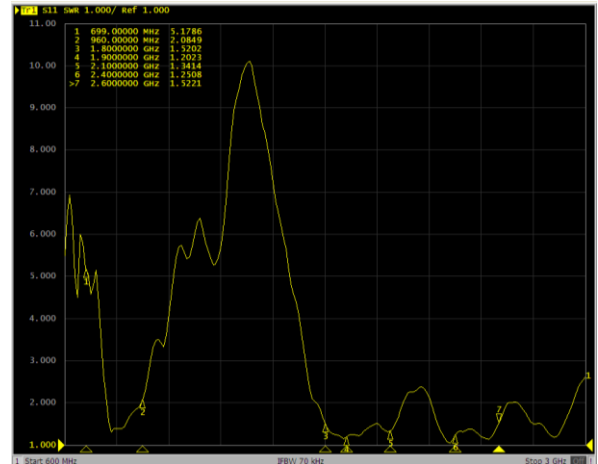

Tested with 30cm cable length and 6mm thin glass.

Tested with 30cm cable length and 6mm thin glass.

3.2. 3D Spherical

- Legend bar is showing antenna gain

Freq = 0.8500GHz Az= 45 EL= 45

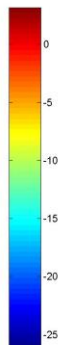
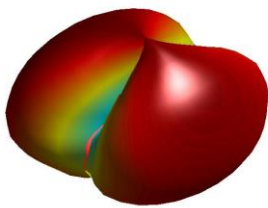

Freq = 0.9GHz Az= 45 EL= 45

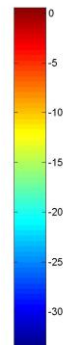
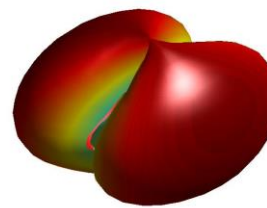

Freq = 1.8GHz Az= 45 EL= 45

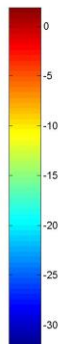
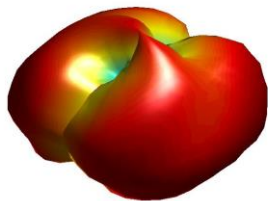

Freq = 1.9GHz Az= 45 EL= 45

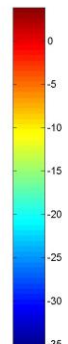
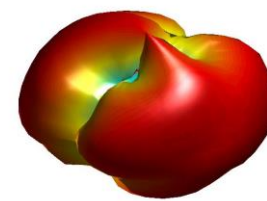

Freq = 2.1GHz Az= 45 EL= 45

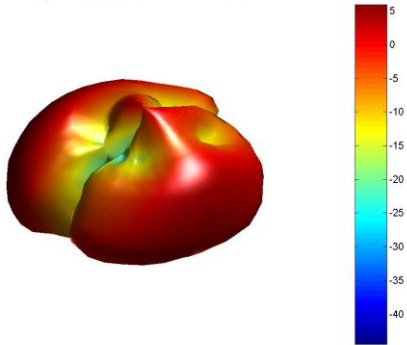

Freq = 2.41GHz Az= 45 EL= 45

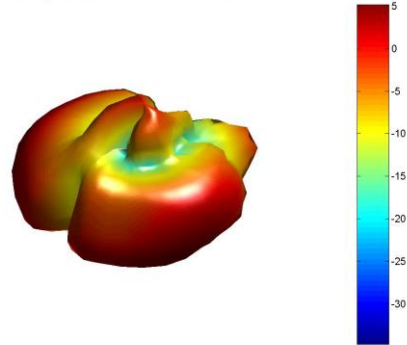

Freq = 2.6GHz Az= 45 EL= 45

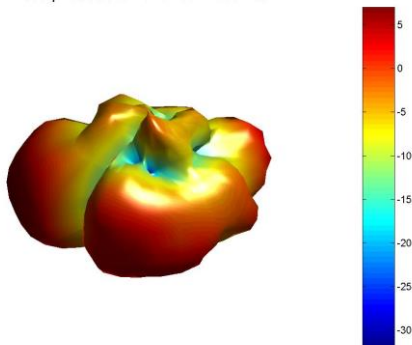



SCATTERGOOD & JOHNSON LTD

ELECTRICAL ENGINEERING & FLUID CONTROL DISTRIBUTORS

Est.1899

At Scattergood & Johnson Ltd, we pride ourselves on being a technical distributor to specialist industries.

Working with a range of quality product suppliers across a number of specialist markets, we are not your average 'box shifter' - we are your technical and supply chain partner.

We fully support every product we sell - for free! Our internal team and external sales engineers can answer any product or application question, no matter the complexity.

Backing up this technical ability is a range of 50,000+ products available from stock for nationwide next day delivery (same day if required!), or you can collect what you need from any of our trade counters around the UK.

Select your specialist interest below to learn more about how we can help.



Online, In Branch and On the Road - Scattergood & Johnson Ltd, there when you need us.

www.scatts.co.uk