

# K107A

## RS485 ↔ RS485 SERIAL ISOLATOR/AMPLIFIER

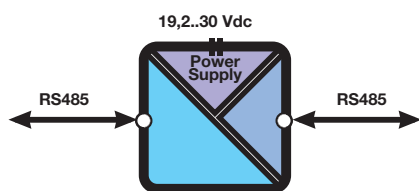

K107A is an amplifier for RS485 serial line. It's used in order to extend both the length or the number of devices admitted (max 32) on RS485 serial line. Useful also when a star connection needed that usual is not possible with RS485 line.

### TECHNICAL SPECIFICATIONS

#### General Data

Power supply	19,2..30 Vdc
Side Power	Yes
Hot swapping	yes
Max current consumption	22 mA (24 Vdc)
Max power consumption	500 mW
Rejection	50 – 60 Hz (configurable)
Settings	DIP switches
Filter	Insertable
Dimensions (w x h x d)	6,2 x 93,1 x 102,5 mm
Isolation	1,5 kVac (3-way)
Isolation technique	Digital (optocoupler)
Data processing	32 bit floating point
Colour	Black
Enclosure	PBT
Weight	45 g
Operating temperature	-20..+65 °C
Connections	Clamp terminals / bus
Protection degree	IP20
Channels	1 input, 1 output
Status indicators	Power ON Data Inverted connection
Communication	Automatic handshake Baud rate: 1.200..115.200 bps
Approvals	CE, UL-UR CSA
Norms	EN 61010-1, EN 60742, EN 61000-2, EN 61000-4

#### DATA X SIDE

Type	SERIAL RS485 Half duplex, 31 nodes, line termination, protection up to 30 Vdc
------	--

#### DATA Y SIDE

Type	SERIAL RS485 half duplex, 31 nodes, terminal, protection up to 30 Vdc
------	--

### APPLICATION NOTE

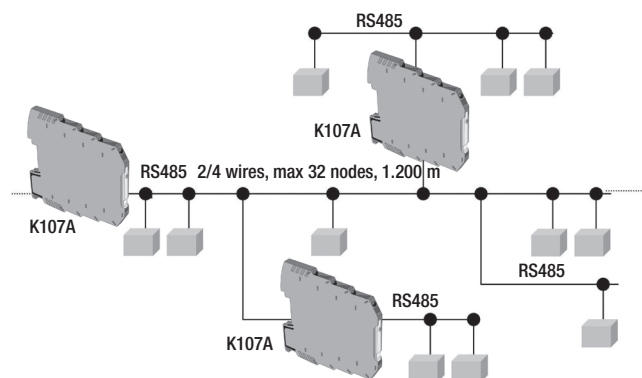

### ORDER CODES

Code	Description
K107A	RS485 ↔ RS485 serial isolator/amplifier

### ACCESSORIES & SOFTWARE



**K-BUS**  
Backplane for power connection  
pg. 114

### SIMILAR PRODUCTS



**S107USB**  
RS485 ↔ USB serial converter (desk)  
pg. 49



**K107USB**  
RS485 ↔ USB serial converter  
pg. 54



**K107B**  
RS232 ↔ RS485 serial isolator/amplifier  
pg. 53



# SCATTERGOOD & JOHNSON LTD

ELECTRICAL ENGINEERING & FLUID CONTROL DISTRIBUTORS

Est.1899

At Scattergood & Johnson Ltd, we pride ourselves on being a technical distributor to specialist industries.

Working with a range of quality product suppliers across a number of specialist markets, we are not your average 'box shifter' - we are your technical and supply chain partner.

We fully support every product we sell - for free! Our internal team and external sales engineers can answer any product or application question, no matter the complexity.

Backing up this technical ability is a range of 50,000+ products available from stock for nationwide next day delivery (same day if required!), or you can collect what you need from any of our trade counters around the UK.

Select your specialist interest below to learn more about how we can help.



Online, In Branch and On the Road - Scattergood & Johnson Ltd, there when you need us.

# [www.scatts.co.uk](http://www.scatts.co.uk)