



Z109UI2-1

mA - V CONVERTER WITH GALVANIC ISOLATION AND Micro USB INTERFACE

Highlights

- **Power supply: 9..40 Vdc, 19..28Vac 50- 60 Hz**
- **Transducer power supply: 2 wires, 20 Vdc stabilized, 20 mA max protected from short circuit**
- **Input: voltage (bipolar) from 100 mV to 20 V in 9 scales), Current (bipolar up to 20 mA)**
- **Retransmitted output: voltage (0..10/ 2...10 V), current (0...20 / 4..20mA) active or passive**
- **Accuracy: 0.1% (for input in voltage / current)**
- **Sampling frequency/ Resolution: 240 sps(@11bit+sign) at 15 sps(@15bit+sign)**
- **Operating temperature: - 10..60°C**
- **Isolation: 1,500 @3 points**
- **Configuration: By DIP switch, software (Windows PC), App (Android)**
- **Connection: Micro USB port on the front of the module**
- **Certifications: CE, UL**



100% Made & Designed in Italy

Z1090UI2-1 is a voltage to current converter with 3-point isolation 1500 Vac and sensor power supply in 2-wire technique (20 Vdc stabilized, 20 mA max, protected against short circuit).

Measurement and retransmission of the data is done on isolated analog output, with voltage output or in active/passive current.

Through DIP-switches are selectable type of input, START-END, output mode (zero elevation, inversion, scale), output type (mA or V).

Heir to the Z109UI2, Z109UI2-1 converter has on the front side the communication port in format Micro USB (replacing the 3.5 mm jack port). Through the Micro USB it is possible to configure the module not only via PC but also via mobile app "EASY Setup App".



 **SENECA**
www.seneca.it

Z109UI2-1



mA - V CONVERTER WITH GALVANIC ISOLATION AND Micro USB INTERFACE

TECHNICAL DATA

GENERAL DATA

Power supply	10..40 Vdc; 19..28 Vac
Power transducers	Yes, 2-wire, 20 Vdc stabilized, 20 mA max
Power consumption	1,6W (@24Vdc, 20mA output); 2,5W (max)
Isolation	1.500 Vac (3 ways)
Protection degree	IP20
Pollution degree	2
LED status indicators	Power supply Off Scale, Burn Out or Internal Failure Dip switch setting error
Response time	35..140 ms
Interfaces	Micro USB (front panel)
Accuracy class	0,1% (V/mA input) - 0,3% (voltage output)
Thermal drift	0,01%/°K
Settings	DIP switch Jumper Software PC Windows (EASY SETUP) APP Android (EASY SETUP APP)
Data memory	EEPROM, retention time 40 years
Operating temperature	-10..+60°C
Dimension (wxhxd)	100 x 112 x 17,5 mm
Connection	3-way removable terminals, pitch 5.08 mm, section 2,5 mm ²
Case	PA6 black colour
Mounting	35 mm DIN rail (IEC/EN 60715)
Weight	Approx 200 g
Approvals	CE, UL UR CSA
Norms	EN 61000-6-4, EN 61000-6-2, EN 61010-1

INPUT DATA

Channels	1
Voltage	Bipolar from 100 mV up to 20 V in 9 scales, input impedance 1 M Ω , resolution max 15 bit + sign
Current	Bipolar up to 20 mA, input impedance ~ 50 Ω , resolution max 1 μ A
Sampling frequency	240 sps (@11bit+sign)
Response time	35 ms (@11bit)

OUTPUT DATA

Channels	1
Voltage	0..5, 0..10, 1..5, 2..10 V, min load resistance 2 k Ω
Current	0..20, 4..20 mA, max load resistance 600 Ω
Resolution	2,5 μ A/ 1.25 mV

ISOLATION DIAGRAM

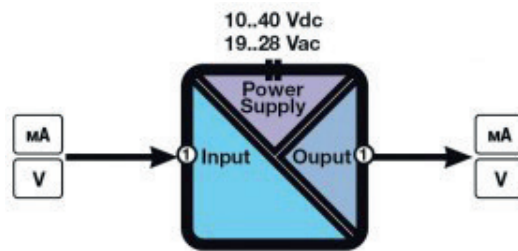

APPLICATION EXAMPLE

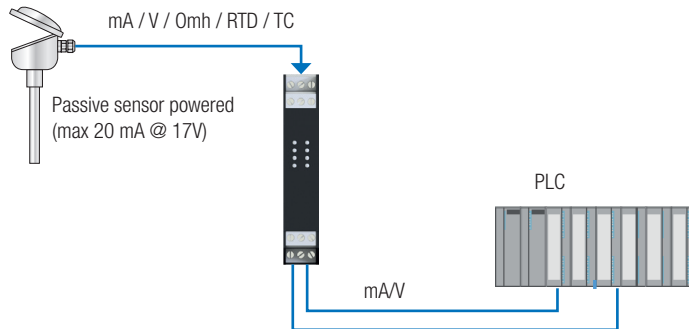

CONFIGURATION VIA USB INTERFACE

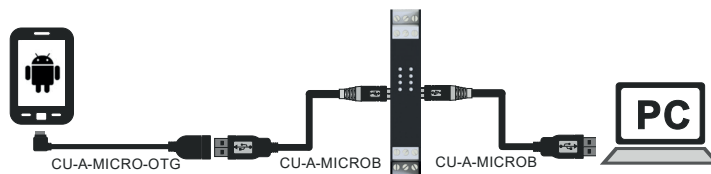

ORDER CODES

Code	Description
Z109UI2-1	mA - V converter with galvanic isolation and Micro USB interface
CU-A-MICROB	Communication cable USB-Micro USB, 1 mt
CU-A-MICRO-OTG	Adapter cable Micro USB OTG - USB Type A female for mobile devices
EASY SETUP	Plug&play suite configurators for programmable instruments
EASY SETUP APP	App iOS / Android Suite Complete EASY SETUP
Z-POWER-115-15VA	DIN rail transformer 19 Vac, 115 / 15 VA with thermal fuse
Z-POWER-230-15VA	DIN rail transformer 19 Vac, 230 / 15 VA with thermal fuse
Z-POWER-230-25VA	DIN rail transformer 19 Vac, 230 / 25 VA with thermal fuse
Z-SUPPLY	Single-phase switching power supply 24V @ 1.5 A



SCATTERGOOD & JOHNSON LTD

ELECTRICAL ENGINEERING & FLUID CONTROL DISTRIBUTORS

Est.1899

At Scattergood & Johnson Ltd, we pride ourselves on being a technical distributor to specialist industries.

Working with a range of quality product suppliers across a number of specialist markets, we are not your average 'box shifter' - we are your technical and supply chain partner.

We fully support every product we sell - for free! Our internal team and external sales engineers can answer any product or application question, no matter the complexity.

Backing up this technical ability is a range of 50,000+ products available from stock for nationwide next day delivery (same day if required!), or you can collect what you need from any of our trade counters around the UK.

Select your specialist interest below to learn more about how we can help.



Online, In Branch and On the Road - Scattergood & Johnson Ltd, there when you need us.

www.scatts.co.uk