

# MODULAR CONVERTERS FOR ELECTRIC READINGS



## Z204-1 TRMS CONTINUOUS AND ALTERNATE VOLTAGE CONVERTER

### TECHNICAL DATA

#### GENERAL DATA

Power supply	10..40 Vdc 19..28 Vac (50..60 Hz)
Absorption	1 W
Insulation	4,000 Vac (input/output, input/power supply) 1,500 Vc (output/power supply)
State indicators	Power supply, Error Communication RS485
Response time	For a step variation 1 s from 10 to 90 %
Communication interfaces	RS485 (backplane): As an alternative to the analogue output, speed up to 115,200 bps, ModBUS RTU protocol RS232 (front connector for programming): baud rate, address, parity, data/stop bit
Precision class	0,5% input; 0,1% outputs.
Thermal drift	+100 ppm/K
Operating temperature	-20..+65°C
Connections	Screw removable terminals
Dimensions	35 x 100 x 112 mm
Weight	140 g
Settings	Dip-switch (address, baud rate, line terminator, input range) EASY-SETUP (Plug&Play software)
Certifications	EC
Regulations	EN 61000-6-4, EN61000-6-2, EN61010-1

#### INPUT DATA

Channels	1
Type	CONTINUOUS VOLTAGE: 0..1,200 Vdc; ALTERNATE VOLTAGE 0..850 Vac Input impedance: 800 kΩ Frequency: 30..300 Hz

#### OUTPUT DATA

Channels	1
Type	CURRENT Range: 0..20 mA; max impedance: 500 Ω VOLTAGE Range: 0..10 V; Min impedance: 1 kΩ

### APPLICATION EXAMPLE

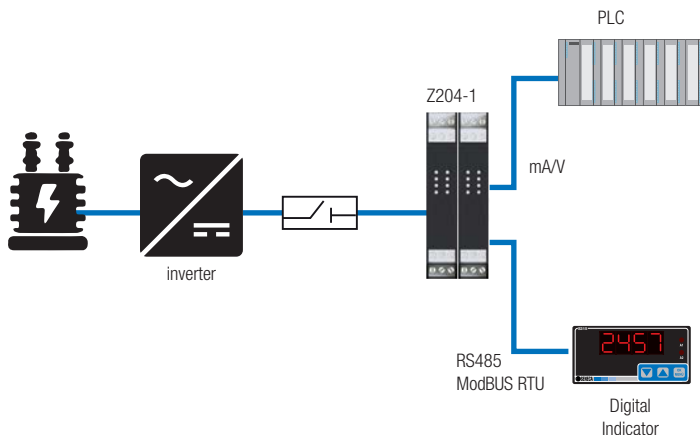

#### ORDER CODE

Code	Description
Z204-1	TRMS alternate and continuous voltage converter



**SCATTERGOOD  
& JOHNSON LTD**  
ELECTRICAL ENGINEERING & FLUID CONTROL DISTRIBUTORS

Est.1899

At Scattergood & Johnson Ltd, we pride ourselves on being a technical distributor to specialist industries.

Working with a range of quality product suppliers across a number of specialist markets, we are not your average 'box shifter' - we are your technical and supply chain partner.

We fully support every product we sell - for free! Our internal team and external sales engineers can answer any product or application question, no matter the complexity.

Backing up this technical ability is a range of 50,000+ products available from stock for nationwide next day delivery (same day if required!), or you can collect what you need from any of our trade counters around the UK.

Select your specialist interest below to learn more about how we can help.



Online, In Branch and On the Road - Scattergood & Johnson Ltd, there when you need us.

**[www.scatts.co.uk](http://www.scatts.co.uk)**