

Protect yourself when machining
 Protegez-vous à l'usinage
 Protégase al mecanizar
 Schützen Sie sich beim Bohren
 Proteja-se ao usinar
 Proteggersi durante la perforazione
 Защитите себя во время бурения
 进行操作加工时，请做好防护措施

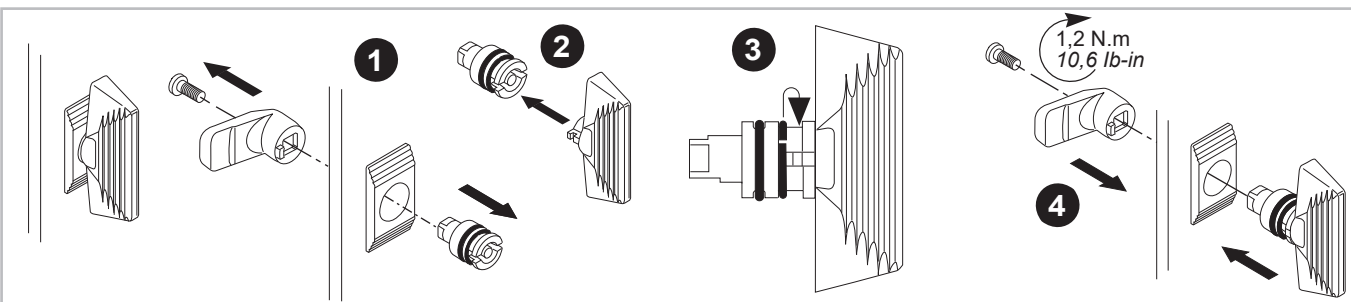
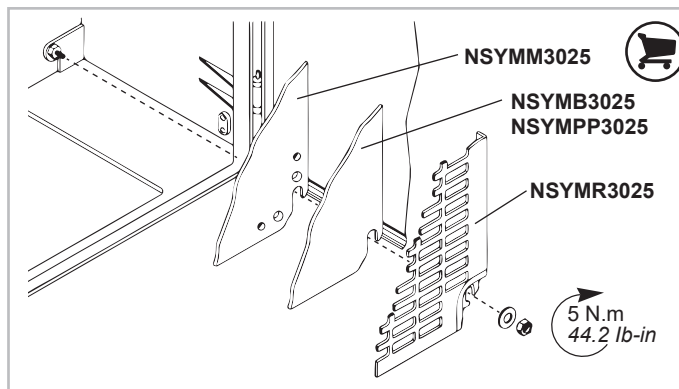
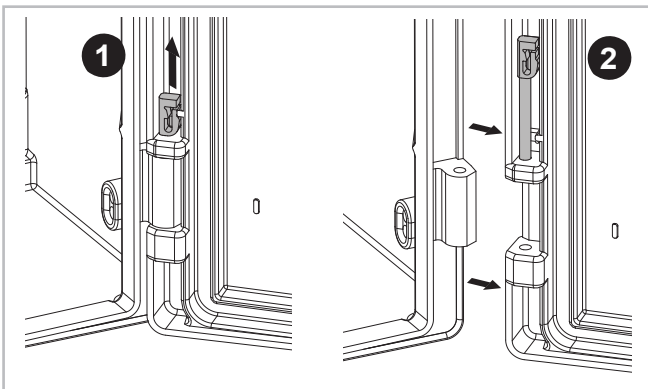
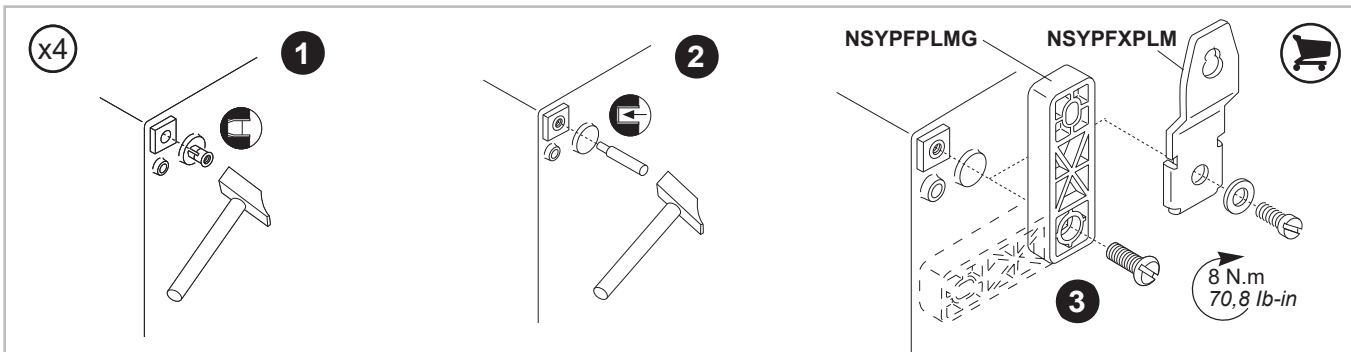
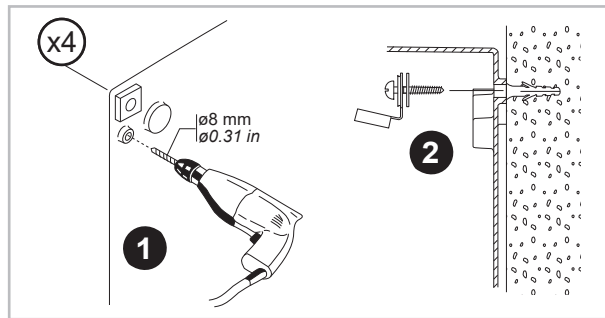

CAUTION / ATTENTION / ATENCIÓN / VORSICHT / ATTENZIONE / CUIDADO / 小心 / ВНИМАНИЕ	
<p>HAZARD OF EQUIPMENT DAMAGE Respect the information provided in the instruction to ensure the functioning of the product. Failure to follow these instructions can result in injury or equipment damage.</p>	<p>RISQUE DE DETERIORATION DU MATERIEL Respecter les informations fournies sur la notice pour garantir le fonctionnement du produit. Si ces directives ne sont pas respectées, cela peut entraîner des blessures ou des dommages matériels.</p>
<p>RIESGO DE DETERIORO DEL MATERIAL Respetar la información proporcionada en las instrucciones para garantizar el funcionamiento del producto. El incumplimiento de estas instrucciones puede causar lesiones o daño al equipo.</p>	<p>GEFAHR VON MATERIALSCHÄDEN Beachten Sie die Angaben in der Betriebsanleitung zur Verfügung gestellt, um die Funktionsweise des Produkts zu gewährleisten. Die Nichtbeachtung dieser Anweisungen kann Verletzungen oder Sachschäden zur Folge haben.</p>
<p>RISCHIO DI DANNI ALLE APPARECCHIATURE Rispettare le istruzioni fornite per garantire il funzionamento del prodotto Il mancato rispetto di queste istruzioni può provocare infortuni o danni alle apparecchiature.</p>	<p>RISCO DE DETERIORAÇÃO DO MATERIAL Respeitar as informações fornecidas no manual de instruções para assegurar o funcionamento do produto. A não observância destas instruções pode provocar ferimentos pessoais, ou danos no equipamento.</p>
<p>设备受损风险 为保证正常使用该产品请仔细阅读本产品说明书。 不遵循上述说明可能导致人身伤害或设备损坏。</p>	<p>ОПАСНОСТЬ ПОВРЕЖДЕНИЯ ОБОРУДОВАНИЯ Следуйте информации, указанной в инструкции, для гарантии правильного функционирования продукта. Несоблюдение этих инструкций может привести к травме или повреждению оборудования.</p>

Schneider Electric Industries SAS
 35, rue Joseph Monier
 CS 30323
 F - 92506 Rueil Malmaison Cedex

www.schneider-electric.com

NHA4686501-01





SCATTERGOOD & JOHNSON LTD

ELECTRICAL ENGINEERING & FLUID CONTROL DISTRIBUTORS

Est.1899

At Scattergood & Johnson Ltd, we pride ourselves on being a technical distributor to specialist industries.

Working with a range of quality product suppliers across a number of specialist markets, we are not your average 'box shifter' - we are your technical and supply chain partner.

We fully support every product we sell - for free! Our internal team and external sales engineers can answer any product or application question, no matter the complexity.

Backing up this technical ability is a range of 50,000+ products available from stock for nationwide next day delivery (same day if required!), or you can collect what you need from any of our trade counters around the UK.

Select your specialist interest below to learn more about how we can help.



Online, In Branch and On the Road - Scattergood & Johnson Ltd, there when you need us.

www.scatts.co.uk