

4.10

Ex-Tank inspection luminaire KFL

(Zone 1, 2, 21, 22)

4

The compact luminaire for the process industry

The robust and compact explosion-protected KFL tank inspection light fitting is used in all sectors of the process industry for the illumination of boiler interiors, tanks and agitators. The light features special mounting stands which can be attached to different inspection windows of sizes DN 40 to DN 200 in accordance with DIN 28120. As an option, the KFL can be easily carried and stably placed by a carry handle for temporary illumination. The housing is made of copper-free aluminium and has a lens made of impact-resistant borosilicate glass. The aluminium collar has a PTFE coating (Teflon) and is sealed with a Viton seal.

Multifunctional use

In addition to the use for illuminating boilers, this tank inspection light fitting can be used in combination with a carry handle as a maintenance and repair light. High-voltage halogen reflector lamps as well as high-power LED lamps can be used. In addition to that, versions are also available in low voltage applications for halogen reflector as well as for LED lamps.

The extremely robust design of this fitting, the resistance to chemicals and UV and the high degree of protection IP 66 allow the use of this light fitting even under extremely harsh conditions.



Features

- Compact design
- Portable version with carry handle available
- Ready to connect for 230 V AC and low voltage 12/24 V AC/DC
- For up to 50 W halogen reflector lamp or high-power LED lamp up to 10 W
- High luminous efficacy
- Generously dimensioned terminal compartment
- Mounting onto inspection windows according to DIN 28120
- High degree of protection IP66

Ordering details



Type	Content	Lamp / Illuminant	Weight	Cable gland/ thread	Threaded plug	Order No.
KFL						
KFL 7 LED	incl. lamp	GU10 lamp socket 5.5 W 230 V LED (incl.)	3 kg	2 x M25, metal thread	1 x M25	NOR 000 005 140 906
KFL 7 LED	without lamp	GU5.3 lamp socket (without lamp) for LED lamps up to 10 W 12/24 V	3 kg	2 x M25, metal thread	1 x M25	NOR 000 005 140 031
KFL 50 IM	without lamp	GU10 lamp socket (without lamp) for 50 W 230 V Halogen	3 kg	2 x M25, metal thread	1 x M25	NOR 000 005 140 900
KFL 50 IM	incl. lamp	GU5.3 lamp socket 50 W 24 V Halogen (incl.)	3 kg	2 x M25, metal thread	1 x M25	NOR 000 005 140 030
KFL 50 IM	incl. lamp	BA15 D lamp socket 50 W 12 V Halogen (incl.)	3 kg	2 x M25, metal thread	1 x M25	NOR 000 005 140 920
Portable KFL 7 LED	incl. lamp, carry handle	GU10 lamp socket 5.5 W 230 V LED (incl.)	6 kg	2 x M25, metal thread	1 x M25	NOR 000 005 140 907
Portable KFL 7 LED	without lamp incl. carry handle	GU5.3 lamp socket (without lamp) for LED lamps up to 10 W 12/24 V	6 kg	2 x M25, metal thread	1 x M25	NOR 000 005 140 032

Accessories



Type	Content	Application	Order unit	Order No.
LED lamp	LED lamp 5.5 W Socket GU 10	KFL 7 LED	1	NOR 000 000 514 531
Lamp	Halogen reflector lamp 24 V/50 W, 38° socket GU 5.3	KFL 50 IM	1	NOR 000 000 514 524
Lamp	Halogen reflector lamp 12 V/50 W, 8° socket BA 15D	KFL 50 IM	1	NOR 000 000 514 687
AT	Carry handle	KFL..	1	NOR 000 005 140 809
PAD	Antiglare shield	KFL..	1	NOR 000 005 140 700
PI	Mounting stands bended	KFL..	1	NOR 000 005 140 776

Scope of delivery without lamp, if not stated otherwise.
Metal cable glands see catalogue part 2: 2.3.12 ff

4.10

Dimension drawing / Polar curve

KFL

Polar curve KFL 50 IM

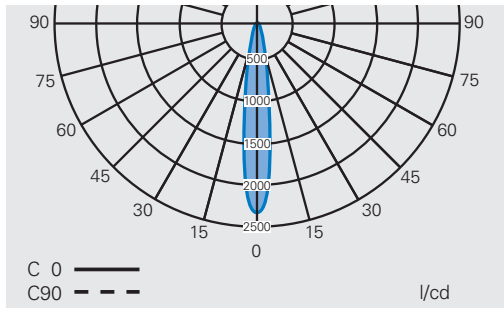

KFL 50 IM / 7 LED

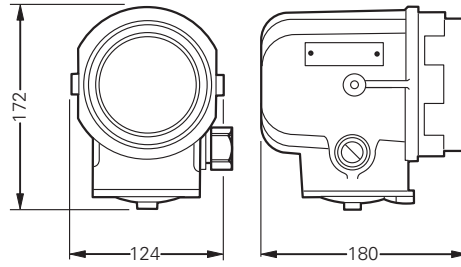

Polar curve KFL 50 IM / 7 LED

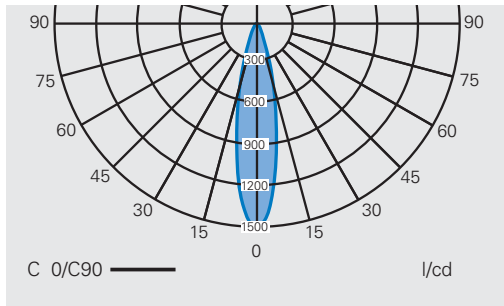

Portable KFL 7 LED

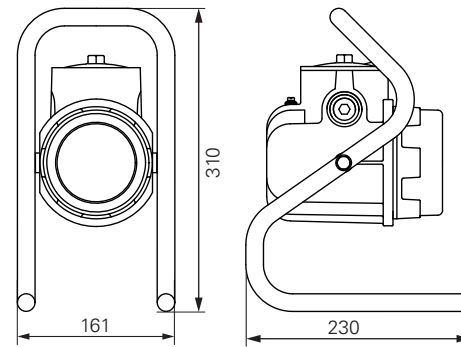

Light fixing facility PI

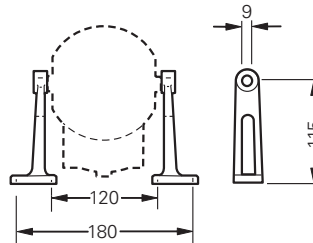

Allowed tank windows, nominal width

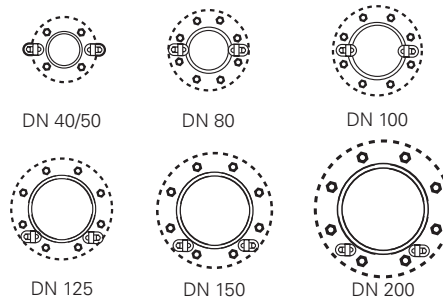

Dimensions in mm



SCATTERGOOD & JOHNSON LTD

ELECTRICAL ENGINEERING & FLUID CONTROL DISTRIBUTORS

Est.1899

At Scattergood & Johnson Ltd, we pride ourselves on being a technical distributor to specialist industries.

Working with a range of quality product suppliers across a number of specialist markets, we are not your average 'box shifter' - we are your technical and supply chain partner.

We fully support every product we sell - for free! Our internal team and external sales engineers can answer any product or application question, no matter the complexity.

Backing up this technical ability is a range of 50,000+ products available from stock for nationwide next day delivery (same day if required!), or you can collect what you need from any of our trade counters around the UK.

Select your specialist interest below to learn more about how we can help.



Online, In Branch and On the Road - Scattergood & Johnson Ltd, there when you need us.

www.scatts.co.uk