

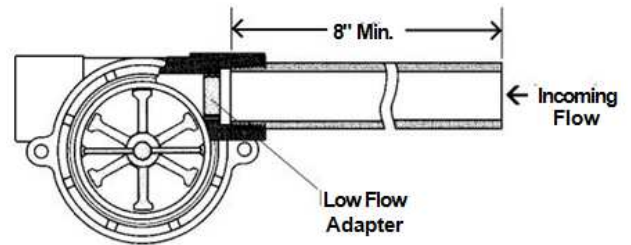

RFS-2500 Series RotorFlow® Sensors

(For Additional Information, See Gems' "Level, Flow and Pressure Catalog)

RotorFlow units monitor dynamic fluid flow. The rotor reacts to turbulence, pulsation, entrained air, and other flow anomalies induced in the flow stream by other process hardware. For optimum performance, install RotorFlow units where nominal flow conditions exist, with ports located at the top. Incoming flow may be placed to either port. A minimum of 8" of straight pipe on the inlet side is recommended.



Low Flow Applications

A low flow adapter is supplied with all RotorFlow units. It is used to produce accurate response at low flow rates. Press fit the adapter as shown above, in the port selected for incoming flow. **See Flow Range Chart below.**

Body Material	Port Size NPT	Input Power	Part Number	Flow Range-GPM		
				Standard Range	Low Flow* Range	Adapter Part Number
Polypropylene	.25"	12 VDC	155424	0.5 - 5.0	0.1 - 1.0	152147
		24 VDC	155425			
		110 VAC	155876			
	.50"	12 VDC	155484	4.0 - 20.0	1.5 - 12.0	151832
		24 VDC	155485			
		110 VAC	155886			
Brass	.25"	12 VDC	156264	0.5 - 5.0	0.1 - 1.0	152147
		24 VDC	156265			
		110 VAC	156266			
	.50"	12 VDC	156267	4.0 - 20.0	1.5 - 12.0	151832
		24 VDC	156268			
		110 VAC	156269			
	.75"	12 VDC	180394	5.0 - 30.0	N/A	N/A
		24 VDC	180395			
		110 VAC	180396			
	1.0"	24 VDC	181688	8.0 - 60.0	N/A	N/A
		115 VAC	181689			
	316 Stainless Steel	9/16"-18**	24 VDC	165073	0.5 - 5.0	0.1 to 1.0
110 VAC			165074			
.50"		24 VDC	165077	4.0 to 20.0	1.5 to 12.0	151832
		110 VAC	165078			
.75"		24 VDC	181691	5.0 - 30.0	N/A	N/A
		115 VAC	181692			
1.0"		24 VDC	181693	8.0 - 60.0	N/A	N/A
		115 VAC	181694			

* With use of low flow adapter supplied

** Straight thread with O-ring seal

Installation: RotorFlow sensors connect to piping via NPT mating threads forms. The following guidelines are provided to assist with installation for a leak-free seal, without damage to the unit: 1) Apply pipe thread sealant to male pipe threads. 2) Thread RotorFlow unit onto male pipe thread until hang-tight . 3) Tighten pipe 1 to 1/2 additional turns. 4) If improper seal results, continue turning pipe into unit in 1/4 turn increments. **Do not exceed one additional turn.**

Recommended pipe Sealants:

(a) Permatex[®] "No More Leaks" (b) Teflon[®] Thread Tape.

Filtration and Cleaning: 150 micron filtration is recommended. However, should foreign particles enter the RotorFlow sensor, accumulation is easily cleared by removing the lens from the body. The lens is removed by turning its center rib 45° counter-clockwise and then pulling it out. To reinstall the lens, simply reverse the process. **Pressure must be relieved** from the system prior to sensor clean-out.

Panel Mounting

Any RotorFlow sensor may be panel mounted using holes integrated into the bodies.

Plastic Bodies

Two (2) mounting ears are provided at the body centerline to receive #8 Self- tapping screws. (*Brass and stainless steel bodies use 8-32 UNC2B screws.*)

See recommended panel preparation diagram. **Note:** ANSI T Type 23 self-tapping screws are recommended for plastic. They may be replaced with standard machine screws if reinstallation should be required.

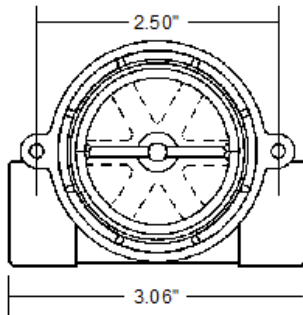

Plastic, Brass , Stainless Steel

1/4", 1/2", 9/16"-18

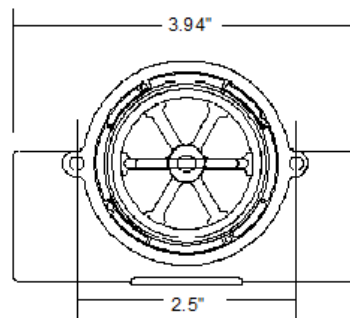

Brass/Stainless Steel

3/4" & 1"

Note

A RotorFlow Repair Kit is available, including the following replacement parts: lens, O-ring, shaft, and rotor. Consult Factory to order.

Switch Set Point Calibration with LED Signal

With the unit installed in the line and power supplied, complete the following steps to calibrate switch actuation point with proper flow rate. A small flat-blade screwdriver is all that is required.

1. Adjust liquid flow in the line to the rate at which actuation is desired.
2. Insert screwdriver into opening on backside of housing and fit blade into the potentiometer adjustment screw inside.
3. If LED is not illuminated, slowly turn screwdriver counter-clockwise and stop as soon as LED illuminates.
4. If LED is illuminated, turn screwdriver clockwise until LED light goes out. Then, slowly turn screwdriver counter-clockwise and stop as soon as LED illuminates.

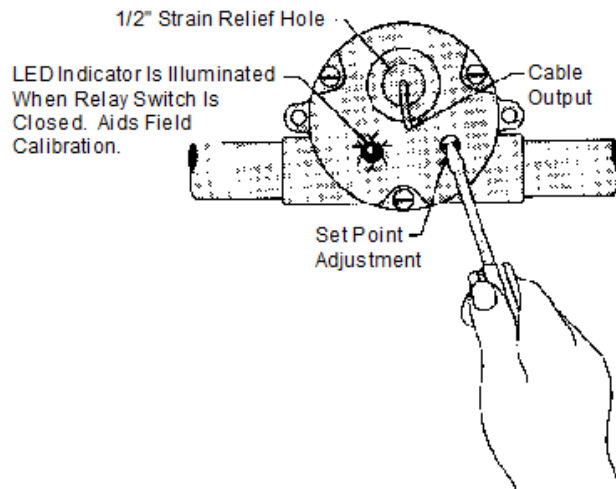

Specifications

<u>Wetted Materials</u>	
Body	Brass, 316 SS or Polypropylene, Hydrolytically Stable, Glass-Reinforced†
Rotor Pin	Ceramic
Rotor	PPS Composite/Teflon/PPS Composite
Lens	Polysulfone
O-Ring	Buna N/Viton
<u>Operating Pressure, Max. Brass</u>	
Body & 316 SS Body	200 PSIG @ 70°F 80 PSIG @ 212°F
Polypropylene Body	100 PSIG @ 70°F 40 PSIG @ 212°F
<u>Operating Temperature, Max.</u>	
Brass Body	212°F (100°C)
Polypropylene Body	180°F (82.2°C)
316 SS Body	212°F (100°C)
Electronics (All Bodies)	150°F (65.5°C)
Viscosity, Max.	200 SSU
Input Power	12 VDC, 24 VDC or 110 VAC
Relay Contact Ratings (SPDT)	1 Amp, 24 VDC Resistive 0.3 Amp, 110 VAC
Repeatability	2% Maximum Deviation
Set Point Accuracy (Factory Set)	±5%
Set Point Differential	15% Maximum
Electrical Termination	22 AWG PVC-Jacketed, 24" Cable. Color codes: Red = +VAC/VDC; Black = Ground; White = N.O. Contact; Brown = N.C. Contact; Green = Common.

† Hydrolytically stable, glass-reinforced, Polypropylene is UL-recognized to UL746B at a relative temperature index of 65°C

Electrical Data

Input power and output are connected via a Multi-conductor, PVC-jacketed 24" cable.

Color codes are as shown below:

+VAC/VDC	Red
-Power	Black
N.O. Contact	White
N.C. Contact	Brown
Common	Green

WARNING

When determining chemical compatibility of materials of construction, the flow media and application-associated environmental conditions should be carefully considered.



This product is suitable for Class I and Class II applications only, per the requirements of standard EN60730 and any additional specific requirements for a particular application or medium being sensed. Class I compliance of metal bodied units requires a ground connection between the metal body and the earthing system of the installation. Class I compliance of plastic bodied units in contact with a conductive medium requires that the medium be effectively earthed so as to provide an earthed barrier between the unit and accessible areas. For Class III compliance, a supply at safety extra-low voltage (SELV) must be provided. Please consult the Factory for compliance information on specific part numbers.

Important Points!

Product must be maintained and installed in strict accordance with the National Electrical Code and GEMS product catalog and instruction bulletin. Failure to observe this warning could result in serious injuries or damages.

Pressure and temperature limitations shown on individual catalog pages and drawings for the specified flow switches must not be exceeded. These pressures and temperatures take into consideration possible system surge pressures/temperatures and their frequencies.

Selection of materials for compatibility with the media is critical to the life and operation of GEMS flow switches. Take care in the proper selection of materials of construction; particularly wetted materials.

Life expectancy of switch contacts varies with applications. Contact GEMS if life cycle testing is required.

Ambient temperature changes do affect switch set points, since the specific gravity of a liquid can vary with temperature.

Flow switches have been designed to resist shock and vibration; however, shock and vibration should be minimized.

Liquid media containing particulate and/or debris should be filtered to ensure proper operation of GEMS products.

Electrical entries and mounting points may require liquid/vapor sealing if located in an enclosed tank.

Flow switches must not be field repaired.

Physical damaged sustained by the product may render it unserviceable.



SCATTERGOOD & JOHNSON LTD

ELECTRICAL ENGINEERING & FLUID CONTROL DISTRIBUTORS

Est.1899

At Scattergood & Johnson Ltd, we pride ourselves on being a technical distributor to specialist industries.

Working with a range of quality product suppliers across a number of specialist markets, we are not your average 'box shifter' - we are your technical and supply chain partner.

We fully support every product we sell - for free! Our internal team and external sales engineers can answer any product or application question, no matter the complexity.

Backing up this technical ability is a range of 50,000+ products available from stock for nationwide next day delivery (same day if required!), or you can collect what you need from any of our trade counters around the UK.

Select your specialist interest below to learn more about how we can help.



Online, In Branch and On the Road - Scattergood & Johnson Ltd, there when you need us.

www.scatts.co.uk