



DIRECT CONNECT 100A SINGLE PHASE ENERGY METER - DRS-100-1P CROMPTON INSTRUMENTS

KEY FEATURES

- MID D certified
- Class B (kWh) to EC 2004/22/EC
- Direct connect to 100A
- DIN-rail enclosure DIN 43880
- Import / export kWh
- Modbus™ RTU protocol
- Two pulsed output

TE Connectivity's (TE) Crompton Instruments The DRS range of MID APPROVED, direct connected energy meters represents a multi-function range of kWh meters in the Crompton Instruments portfolio.

The DRS-100-1P, energy meter is an accurate and cost effective solution for measurement and display of importing and exporting energy parameters for single phase networks. Its easy programming, mounting and user-friendly navigation make the DRS-100-1P an ideal choice for customers who require reliable energy measurement.

The product features a DIN-rail enclosure and backlit LCD display.

The DRS-100-1P has two communication interfaces

Modbus™ RTU protocol

Two pulsed outputs

Customers can count on consistent, high quality products, driven by TE's proven innovation and backed by our extraordinary customer support.



Energy Meter - Single Phase

Wiring Diagrams

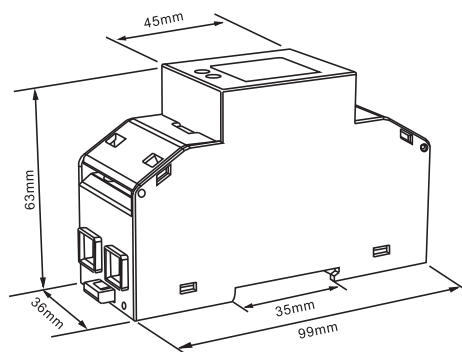
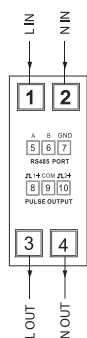

SPECIFICATION

Input	
Nominal input voltage	63.5-276V AC L-N (173-500V L-L) 600V MAX
Max. Continuous input overload voltage	120% of nominal
Max. Short duration input voltage	2 x nominal voltage for 1 second
Nominal input voltage burden	< 0.2VA per phase
Nominal input current	0.5-10 (100A)
Nom. Input current burden	< 0.5 VA
Max. Continuous input overload current	120% of nominal
Max. short duration input current	20 x nominal current for (10 msec)
Accuracy	
Voltage (V)	+/- 0.5% of range maximum
Current (A)	+/- 0.5% of range maximum
Frequency (Hz)	+/- 0.2% of mid-frequency
Power factor (PF)	+/- 1% of unity (0.01)
Active power (W)	+/- 1.0% of range maximum
Reactive power (VAR)	+/- 1.0% of range maximum
Apparent power (VA)	+/- 1.0% of range maximum
Active energy (kWh)	+/- 1.0% of range maximum to IEC 62053-21
Reactive energy (kVARh)	+/- 1.0% of range maximum to IEC 62053-24
Response Time	1 sec, typical, to >99% of final reading at 50Hz
Measured Range	
Voltage (V)	5 - 120% of nominal (Min 100V - self powered)
Current (A)	5 - 120% of nominal
Frequency (Hz)	44 - 66 Hz +/- 2%
Power (W, VAR, VA)	5 - 144% of nominal (bi-directional)
Energy	7 digit, upto 999999.9 kWh / kVARh
Power factor	4 quadrant
Input Waveform	Sinusoidal (distortion factor < 0.05)

Description

Description	Part number
MID energy meter Single phase DIN-rail mounted 100A direct connect Modbus + 2 pulsed outputs	DRS-100-1P-MOD-01

SPECIFICATION

Auxiliary	
Operating range	Self powered
Supply burden	< 10 VA
Environment	
Operating temperature	-25 °C to +55 °C
Storage temperature	-40 °C to +70 °C
Relative humidity	0 to 95%, non-condensing
Shock	30g in 3 planes
Vibration	10Hz to 50Hz, IEC 60068-2-6, 2g
Dielectric voltage	4kV
Altitude	3000m
Warm-up	1 minute
Magnetic field of external origin	Terrestrial flux
Outputs	
Pulsed output relay (configurable)	Opto- coupled, potential-free SPST-NO contact
Contact rating current	2-27mA at 27V DC
Contact rating voltage	5-27V DC
Pulse width	60 / 100 / 200 ms
Pulse rate	0.01 / 0.1 / 1 / 10 / 100 kWh / kVARh Default: 1 pulse per Wh/VArh
Pulsed output relay (non-configurable)	1000 IMP/kWh
Communications	Modbus RTU (RS485)
Type	2-wire half duplex
Baud rate	2400, 4800, 9600, 19.2 K, 38.4 K
Address	1 to 247
Parity	None (default) / Odd / Even
Stop bits	1 (default) / 2
Enclosure	
Enclosure style	DIN-rail to DIN 43880
Dimensions	99x36x63mm (LxWxH)
Protection rating	Front IP51
Material	Self extinguishing UL 94 V-O
Weight	216 g
Cable size	2.5mm ² - 25mm ² stranded cable, AWG 12 - 4.



te.com/energy

© 2019 TE Connectivity. All Rights Reserved. EPP-3370-DDS-6/19-CROMPTON-METER-DRS-100-1P-TE

Crompton, TE Connectivity and TE connectivity (logo) are trademarks. Other logos, product and/or company names might be trademarks of their respective owners. While TE has made every reasonable effort to ensure the accuracy of the information in this brochure, TE does not guarantee that it is error-free, nor does TE make any other representation, warranty or guarantee that the information is accurate, correct, reliable or current. TE reserves the right to make any adjustments to the information contained herein at any time without notice. TE expressly disclaims all implied warranties regarding the information contained herein, including, but not limited to, any implied warranties of merchantability or fitness for a particular purpose. The dimensions in this catalog are for reference purposes only and are subject to change without notice. Specifications are subject to change without notice. Consult TE for the latest dimensions and design specifications.

FOR MORE INFORMATION: TE Technical Support Centers

USA:	+ 1 800 327 6996
Canada:	+ 1 (905) 475-6222
Mexico:	+ 52 (0) 55-1106-0800
Latin/S. America:	+ 54 (0) 11-4733-2200
France:	+ 33 380 583 200
UK:	+ 44 0870 870 7500
Germany:	+ 49 896 089 903
Spain:	+ 34 916 630 400
Italy:	+ 39 333 250 0915
Benelux:	+ 32 16 508 695
Russia:	+ 7 495-790 790 2-200
China:	+ 86 (0) 400-820-6015



SCATTERGOOD & JOHNSON LTD

ELECTRICAL ENGINEERING & FLUID CONTROL DISTRIBUTORS

Est.1899

At Scattergood & Johnson Ltd, we pride ourselves on being a technical distributor to specialist industries.

Working with a range of quality product suppliers across a number of specialist markets, we are not your average 'box shifter' - we are your technical and supply chain partner.

We fully support every product we sell - for free! Our internal team and external sales engineers can answer any product or application question, no matter the complexity.

Backing up this technical ability is a range of 50,000+ products available from stock for nationwide next day delivery (same day if required!), or you can collect what you need from any of our trade counters around the UK.

Select your specialist interest below to learn more about how we can help.



Online, In Branch and On the Road - Scattergood & Johnson Ltd, there when you need us.

www.scatts.co.uk