

SPX/SPZ **SPARTAN**

Bulkhead Range - Installation Guide

Zone 1 variant CML 13ATEX3007 & IEC Ex CML14.0001

Zone 2 variant CML 17ATEX4231 & IEC Ex CML17.0135

This installation guide provides instructions for installing the White-Light SPARTAN series of explosion protected floodlights.

Text in italics is specific for emergency variants.

Overview

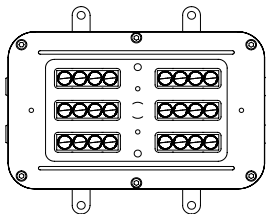

- 1 Safety Instructions
- 2 Installation
- 3 Maintenance
- 4 Technical Specification
- 5 Declaration of Conformity

Important information

The SPARTAN series of explosion protected bulkheads are specialist devices, certified for use in specific operating environments.

The units must be installed in accordance with these instructions, must be correctly certified for the specific operating environment and must be installed by suitably qualified personnel.

If you have any queries about the installation or the certification of the unit – please contact Raytec for immediate assistance and advice.

1. Safety instructions

1. Read this leaflet carefully before commencing to install the SPARTAN Bulkhead unit and retain it for future use. Installation can only be carried out by suitably qualified personnel.
2. Check the certification nameplate attached to the luminaire to ensure that the hazardous zone, mains supply, ambient temperature present and 'T' rating are suitable for the environment the unit is being installed in.
3. If the SPARTAN unit is to be installed in areas of high vibration, please consult with Raytec.
4. The SPARTAN unit housing is constructed from marine grade aluminium and toughened glass. The end user must ensure that these materials are suitable for the environment the SPARTAN unit will be installed in; Zone 1 or Zone 2 Hazardous areas.
5. Check certification nameplate on side of bulkhead to ascertain type of threaded cable entry on the luminaire. Select suitably certified ATEX/IEC Ex cable glands and stopper plugs, these must be parallel thread, have a minimum of 5 full thread engagement and be of a medium/fine tolerance to ISO965-1 and ISO965-3. The cable entry devices selected must maintain the IP rating of the luminaire
6. The incoming mains cable should not exceed a temperature rise of 24°C above the ambient conditions; select suitable cable.

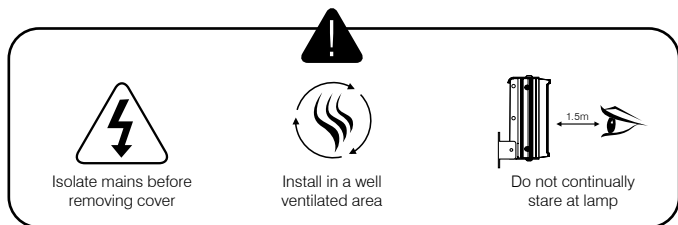

2. Installation

Mounting SPARTAN Unit

1. To meet the requirements of certification a **MINIMUM** of 2 fixing points must be used, the fixing points must be suitable for the conditions of use.

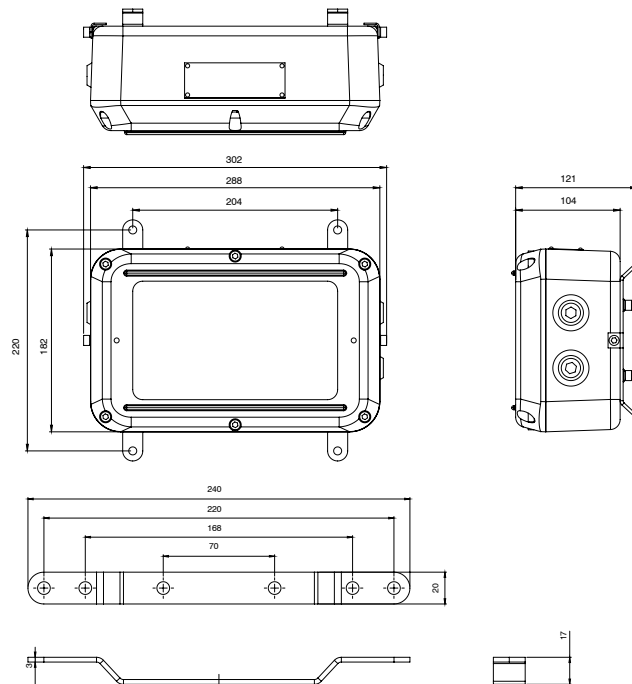

Spartan Bulkhead 24 Floodlight Standard/Emergency Variant

- The unit may have been supplied with an integrated photocell. Care should be taken when positioning the unit to ensure the sensor is not shielded, is not pointing directly at another light source and is monitoring the general, prevailing light conditions.
- The SPARTAN Bulkhead is supplied as standard with the mounting brackets fitted as shown on the above diagram, other mounting methods/brackets available – please contact Raytec.

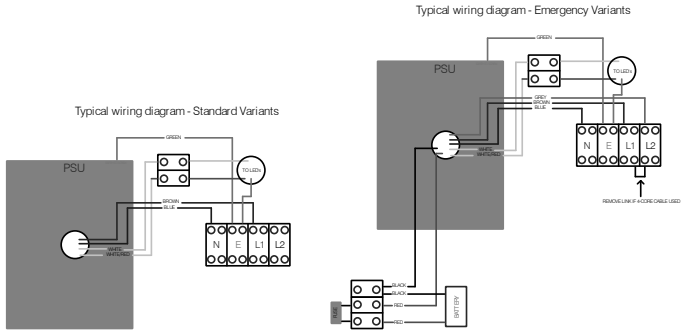

Wire the Mains cable into the terminal block. Provision has been made for this and identified as the E (Earth), L1 (Live switched), L2 (Live permanent) and N (Neutral) terminals. There are two pairs of contacts for each of these to facilitate a mains cable that can be looped in and out of the unit. The L2 terminals on a standard unit are not electrically connected but allows them to be used on the same circuits as *emergency bulkheads*.

- Installer should earth the unit separately – an internal and external earth point are provided as standard
- Connect wires to mains supply.
- If the unit is opened for any reason, disconnect mains – *On emergency luminaires there may be more than one mains supply*
- All SPARTAN floodlights have terminal blocks suitable for looping 4mm² cable, only one cable should be connected to each terminal block connection

- The battery fuse located within the Bulkhead housing on emergency variants is disconnected after final manufacturing testing. When installing the bulkhead the battery fuse will need to be reconnected and the unit charged for 24 hours and then discharged (repeated 3 times) to bring the battery up to peak capacity. (Unless an 'EMX' intelligent emergency variant – see notes below)
- If a 4 core cable is used on emergency luminaires – L1, L2, N and E the link cable at the front of the terminal block between L1 and L2 should be removed
- During emergency operation the light output and duration will be determined by the variant purchased

Spartan Intelligent Emergency Operation Guide

Operation

The light fitting will carry out the following function **automatically** after installation:

- Commissioning Cycle
- Function test
- Self-test

A tri-colour LED indicator displays the light fitting status. The indication colours are shown in table 1.

a. Commissioning Cycle

- Starts automatically 24 hours after installation.
- 3 charge/discharge cycles to maintain battery's full capacity.
- Battery is charged for 24 hours before each discharge cycle.
- No need for manual commissioning

b. Function Test

- Carried out every 7 days.
- Checks the function of the battery, lamp and power supply.
- Lasts for few minutes only.

c. Self-test

- Carried out at a random time every 3 month.
- Checks the battery's capacity and lamp's condition.
- Performs self-recovery for the battery if not at peak capacity.
- Is carried out at 100% load
- Discharges only 2/3 of the battery's capacity.

LED indication

LED Indication	Condition
Blinking amber	Commissioning
Static Amber	Function Test
	Self-test
Blinking Red	Battery defective/Fuse blown
	PSU error
	Battery not at peak capacity
	Light engine failure
No light	Emergency mode activated
Static Green	Battery charged and PSU OK

Notes

- The luminaire will switch off momentarily (<0.5sec) during the transition between a test and normal operation.
- If a test was interrupted by a mains failure, the test will be halted, and the unit will enter emergency mode. Once the mains supply is back, the unit will allow 24 hours to recharge the battery before continuing the tests.
- The self-test is carried out at a random time to eliminate the possibility of having more than one unit undergoing the test at the same time.

3. Maintenance

1. It is essential that all SPARTAN Bulkhead units are maintained in accordance with the requirements of the EN60079-17 standard: (Electrical apparatus for explosive gas atmospheres – other than mines).
2. **IMPORTANT.** No modifications are permitted to the unit, all spare parts must be purchased from the manufacturer, unauthorized modifications or spare parts will invalidate certification and make the equipment dangerous.
3. Isolate the SPARTAN Bulkhead from the mains supply and allow to cool before carrying out any maintenance work.
 - For Emergency variants, battery must be isolated/ connected when a hazardous environment is NOT present prior to carrying out any maintenance work.
4. In the unlikely event of a number of LED's failing, the light engine assembly must be replaced. This is achieved by loosening front cover bolts, disconnecting the white LED cables to power supply, remove four M6 bolts from rear of light engine and pull the light engine assembly clear. Re fitting a light engine is a reversal of the above procedure.
5. The unit has one independent power supply, in the event that the power supply needs to be replaced the cables to the LED and mains terminal block will need to be disconnected, the four M6 bolts released, then the power supply can then be removed. Fitting a new power supply is a reversal of the above procedure.
6. Disposal of packaging, SPARTAN unit and old LED assemblies should be carried out in accordance with national regulations.

PROTECTION/CERTIFICATION

CML13ATEX3007 or IEC Ex CML14.0001
 II 2 GD Ex e mb op is IIC T4 Gb
 Ta -52°C to +55°C (standard variants)
 II 2 GD Ex e mb op is IIC T4 Gb
 Ta -20°C to +46°C (emergency variants)
 Ex tb IIIC T98°C Db
 IP66 & IP67 Ta = -52°C to +55°C
 110V-254V AC or 18-48V AC/18-69V DC

CML17ATEX4231 or IEC Ex CML17.0135
 II 3 GD Ex ec mc op is IIC T4 Gc
 Ta -50°C to +55°C or
 Ex tb IIIC T98°C Dc
 IP66 & IP67 Ta = -50°C to +55°C
 110V-254V AC or 18-48V AC/18-69V DC

Emergency variants restricted to -20°C

4. Technical Specification

	BL24-STD	BL24-EM
Input Voltage	110-254V AC	
Input Current (230Vac, full load)	0.15A	0.2A
Consumption	33W	35W
Power Factor (230Vac, full load)	>0.97	
Mains Frequency	50/60Hz	
Inrush Current (I_{peak} @50%)	20A, $\Delta t < 300\mu s$	
Total Harmonic Distortion (230Vac, full load)	<10%	
IP Rating	IP66/67	
Weight (std)	5Kg	6Kg
Dimensions	See previous pages for line diagrams	
ATEX and IECEx Rating	See below	

Max number of fittings allowed per MCB
(Based on 230V)

MCB Type	Rating	BL24 - STD	BL24 - EM
B	10A	11	10
B	16A	17	15
B	20A	25	22
B	25A	35	32
C	10A	24	20
C	16A	34	28
C	20A	49	44
C	25A	58	55

Inrush Current Typical Curve

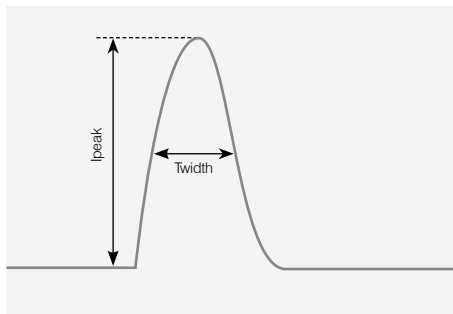

Declaration Of Conformity With The Atex Directive 2014/34/EU



Raytec Ltd. declares under our sole responsibility that the product(s) listed below conform with the relevant provisions of directive 2014/34/EU of 20th April 2016

Manufacturer	Raytec Ltd Unit 15, Wansbeck Business Park Rotary Parkway Ashington Northumberland NE63 8QW United Kingdom
Description of Equipment	Spartan range of bulkhead luminaires – standard and emergency
Notified Bodies	Sira Certification Services (0518) Unit 6 Hawarden Industrial Park Hawarden Deeside CH5 3US
Certificate numbers	Zone 1 - CML13ATEX3007 or IEC Ex CML14.0001 Zone 2 - CML17ATEX4231 or IEC Ex CML17.0135
Equipment Marking	II 2 GD Ex e mb op is IIC T4 Gb Ta -52°C to +55°C (standard variants) II 2 GD Ex e mb op is IIC T4 Gb Ta -20°C to +46°C (emergency variants) Ex tb IIIC T98°C Db IP66 & IP67 Ta = -52°C to +55°C 110V-254V AC or 18-48V AC/18-69V DC II 3 GD Ex ec mc op is IIC T4 Gc Ta -50°C to +55°C Ex tb IIIC T98°C Dc IP66 & IP67 Ta = -50°C to +55°C 110V-254V AC or 18-48V AC/18-69V DC <i>*Emergency variants restricted to -20°C</i>

Compliance with the Essential Health and Safety Requirements has been assessed by reference to the following standards -

IEC 60079-0 : 2012	IEC 60079-7 : 2015	IEC 60079-1 : 2014
IEC 60079-18 : 2015	IEC 60079-25 : 2015	IEC 60079-31 : 2014

And also 2014/35/EU - Low Voltage Directive, 2014/30/EU - EMC Directive

Signed

Name
Position

Barry Thompson
Director of Hazardous Area Division

Dated

Serial number



rayTEC[®]

UK / Europe

T: +44 (0) 01670 520055

hazsales@rayteclcd.com

Americas

T: +1 613 270 9990

ushazsales@rayteclcd.com

www.rayteclcd.com



SCATTERGOOD & JOHNSON LTD

ELECTRICAL ENGINEERING & FLUID CONTROL DISTRIBUTORS

Est.1899

At Scattergood & Johnson Ltd, we pride ourselves on being a technical distributor to specialist industries.

Working with a range of quality product suppliers across a number of specialist markets, we are not your average 'box shifter' - we are your technical and supply chain partner.

We fully support every product we sell - for free! Our internal team and external sales engineers can answer any product or application question, no matter the complexity.

Backing up this technical ability is a range of 50,000+ products available from stock for nationwide next day delivery (same day if required!), or you can collect what you need from any of our trade counters around the UK.

Select your specialist interest below to learn more about how we can help.



Online, In Branch and On the Road - Scattergood & Johnson Ltd, there when you need us.

www.scatts.co.uk