



HEAT INDUSTRIAL

Installation, Operation & Maintenance Instructions Manual HFT and AFT Air Sensing Thermostats



Contents

1. Contact Details	2
2. Description of Equipment.....	3
3. Preservation and Storage Instructions	7
4. Pre-installation Instructions.....	8
5. Installation Instructions.....	9
6. Operating Instructions.....	13
7. Maintenance Instructions	16
8. Special Conditions of Use	19
9. Fault Finding, Correction and Spares	20
10. COSHH Statement.....	22
11. General Arrangement Drawings.....	23
12. Wiring Diagrams.....	25
13. Routine Maintenance Inspection Record	27
14. Certification Documentation	28



EXHEAT Industrial can provide versions of this manual in German, French, Italian, Spanish, Portuguese, Polish, Chinese and Russian. These versions can be requested at support@exheat-industrial.com

To maintain the equipment warranty and, if applicable, the Hazardous Area Certification, the instructions contained within this manual must be complied with in full.



Fitting any other device invalidates the hazardous area certification.

1. Contact Details

Sales Enquiries

EXHEAT Industrial Ltd

Threxton House
Threxton Road Industrial Estate
Watton, Thetford
Norfolk, IP25 6NG

Tel: +44 (0) 1953 886 210

Fax: +44 (0) 1953 883 853

Email: sales@exheat-industrial.com

Website: www.exheat-industrial.com

Technical Support

EXHEAT Industrial Ltd

Threxton House
Threxton Road Industrial Estate
Watton, Thetford
Norfolk, IP25 6NG

Tel: +44 (0) 1953 886 269

Fax: +44 (0) 1953 883 853

Email: support@exheat-industrial.com

Website: www.exheat-industrial.com

2. Description of Equipment

The EXHEAT Industrial Ltd AFT and HFT type flameproof thermostats are designed for the temperature control of work or storage areas, store rooms or cabinets in conjunction with a hazardous area air heater. The HFT is only adjustable internally and the AFT is an externally adjustable version.

HFT Thermostat

Specification

ATEX Markings:

Cert No. Sira 18ATEX1238X

 II 2 G

Ex db IIC T6 Gb

IP66

Certified to:

EN 60079-0:2018

EN 60079-1:2014

Operating Ambient Temperature

$-60^{\circ}\text{C} \leq T_{\text{amb}} \leq +60^{\circ}\text{C}$

IECEx Markings:

Cert No. IECEx SIR 18.0053X

Ex db IIC T6 Gb

IP66

Certified to:

IEC 60079-0:2017 Ed 7

IEC 60079-1:2014 Ed 7

Operating Ambient Temperature

$-60^{\circ}\text{C} \leq T_{\text{amb}} \leq +60^{\circ}\text{C}$

CEC & NEC Markings:

Cert No. 70027793

(CAN-CEC / US-NEC)

Class I Division 2. Groups A, B, C & D.

Temperature Class T6.

TYPE 4X

US (NEC):

Class I Zone 1 AEx db IIC T6 Gb

IP66

Class I Division 2 markings:

Are permitted according to Clause

29.19.4DV in UL60079-0-2012

And Clause 29.1A in CSA C22.2 No.

60079-0:15

CAN (CEC):

Ex db IIC T6 Gb

IP66

Operating Ambient Temperature

$-60^{\circ}\text{C} \leq T_{\text{amb}} \leq +60^{\circ}\text{C}$

CSA Classes C4868-01, C4868-81

CAN/CSA Standard C22.2 No. 0-M91 – General Requirements – Canadian Electrical Code, Part II

CAN/CSA-C22.2 No. 60079-0:15 – Electrical Apparatus for Explosive Gas Atmospheres – Part 0: General Requirements

CAN/CSA-C22.2 No. 60079-1:11 – Electrical Apparatus for Explosive Gas Atmospheres – Part 1: Flameproof Enclosures “d”

CAN/CSA-C22.2 No. 60529:05 – Degrees of Protection Provided by Enclosures (IP Code)

ANSI/UL 60079-0:13 – Electrical Apparatus for Explosive Gas Atmospheres – Part 0: General Requirements

ANSI/UL 60079-0:15 – Electrical Apparatus for Explosive Gas Atmospheres – Part 1: Flameproof Enclosures “d”

ANSI/IEC 60529:2004 – Degrees of Protection Provided by Enclosures (IP Code)

CSA C22.2 No. 24-15 – Temperature Indicating and Regulating Equipment

UL 873 – Temperature Indicating and Regulating Equipment

Specification Continued

CU-TR Markings:

Cert Number EA3C RU C-GB.BH02.B.00026/19

1 Ex db IIC T6 Gb X

Certified to TP TC 012/2011

Enclosure

- Cast 316 stainless steel with 2 off M20x1.5 cable entries and a brass probe housing.

Connections

- The 'Live-in' and 'Live-out' cables are connected to the thermostat using push on type fully insulated crimps (6.3mm, Client supplied).
- The neutral connection is made via the neutral terminal, using a single ferrule to suit 4.0mm² or twin ferrule to suit 2.5mm² conductors max.
- The earth connections (internal and external) are made by use of proprietary ring crimps to suit an M5 fixing and to suit the size of cable installed, the position of the internal earth is located on the internal bracket fixing, the location of the external earthing point is located on the left-hand side on the lower part of the thermostat body.



WARNING – Ensure the correct crimping tool is used for each crimp especially for the internal 'ground/earth' connections.

Controls

- Choice of control range: 0°C to 25°C, 0°C to 40°C or 0°C to 60°C.
- This product is an internally adjustable thermostat that requires the lid to be removed to set the temperature.

Mounting

- 2 off 6.2mm (Clearance) diameter shrouded mounting holes are provided. Please refer to the HFT general arrangement drawing (see section 11) for the dimensions.

Thermostat Rating

- SPDT (Single Pole, Double Throw), MAX 20 Amps MAX 250 volts AC giving a choice of switching configuration (make on rise or break on rise).



CAUTION – Check that the load is compatible with the ratings of the thermostat before energising.

AFT Thermostat

Specification

ATEX Markings:

 II 2 G D
 Ex db IIC T6 Gb
 Ex tb IIIC T85°C Db
 IP66

Certified to:

EN 60079-0:2018
 EN 60079-1:2014
 EN 60079-31:2014
 Operating Ambient Temperature
 $-60^{\circ}\text{C} \leq T_{\text{amb}} \leq +60^{\circ}\text{C}$

IECEx Markings:

Ex db IIC T6 Gb
 Ex tb IIIC T85°C Db
 IP66

Certified to:

IEC 60079-0:2017 Ed 7
 IEC 60079-1:2014 Ed 7
 IEC 60079-31:3013 Ed 2
 Operating Ambient Temperature
 $-60^{\circ}\text{C} \leq T_{\text{amb}} \leq +60^{\circ}\text{C}$

CU-TR Markings:

Cert Number EA3C RU C-GB.BH02.B.00026/19

1 Ex db IIC T6 Gb
 Ex tb IIIC T85°C Db
 Certified to TP TC 012/2011

Enclosure

- Painted cast Aluminium with 2 off M20x1.5 cable entries and a brass probe housing and adjuster (Externally Adjustable).

Connections

- The 'Live-in' and 'Live-out' cables, Neutral and Earth connections are connected to the thermostat using a BK4 terminal block, suitable for 4.0mm² or 2 x 2.5mm² max.
- The internal earth connection is made by use of proprietary ferrule crimp to suit the size of cable installed into the BK4 terminal block, the position of the external earth is located on the right-hand side on the lower part of the thermostat body and is made by use of proprietary ring crimps to suit an M5 fixing.



WARNING – Ensure the correct crimping tool is used for each crimp especially for the internal 'ground/earth' connections.

Controls

- Choice of control range: 0°C to 25°C, 0°C to 40°C or 0°C to 60°C.
- This product is an externally adjustable thermostat and can be adjusted by turning the adjuster using a large screwdriver, without the need to remove the lid.

Mounting

- 3 off 6.2mm (Clearance) diameter shrouded mounting holes are provided. Please refer to the AFT general arrangement drawing (See section 11) for the dimensions.

Thermostat Rating

- SPDT (Single Pole, Double Throw), 20 Amps 250 volts AC giving a choice of switching configuration (make on rise or break on rise) however, it will be wired as break on rise when manufactured.



CAUTION – Check that the load is compatible with the ratings of the thermostat before energising.

3. Preservation and Storage Instructions

Storage



CAUTION – The following preservation instructions must be adhered to, failure to do so could result in the equipment warranty being invalidated:

- Store the equipment at a temperature within the ambient temperature shown on the nameplate.
- Ensure that the equipment is not subjected to direct sunlight at ambient temperatures above +30°C.
- Store the equipment in an inside location that is dry, clean and well ventilated.
- Suitable preservation materials, such as silica gel bags or equivalent, have been placed inside the packaging and inside the enclosure. Additionally, spare silica gel bags, or equivalent, can be purchased by contacting EXHEAT Industrial Ltd.
- Do not store the equipment for more than 3 months unless packed for long term storage.
- If the equipment is stored beyond 3 months, ensure that preservation materials are inspected and replaced if required.



CAUTION – It is the client's responsibility to ensure that, if the terminal enclosure is opened prior to installation, the silica gel bags are checked and replaced if necessary. When refitting the terminal enclosure lid please ensure the O-rings are not damaged or moved in any way, please refer to section 5.

- If practically possible, leave the equipment in its original sealed packaging until required for installation.
- Should it be necessary to open the terminal enclosure, for example to confirm fixings, refer to below:
 - Check the preservation materials and replace them if necessary.
 - Replace the terminal enclosure cover immediately after the work has been undertaken.
 - Reseal the packaging.
- Protect the equipment against external sources of vibration and/or impact.

4. Pre-installation Instructions

Pre-Installation Inspection



Before carrying out the following inspections, take all electronic components in the product out of circuit. Do this by removing control fuses or by physically disconnecting the electronic components.

- Each thermostat is manufactured to the highest standard with great care and quality materials. All the goods are thoroughly inspected and tested before leaving the manufacturing plant, and they must be handled with care during storage and installation. Before the installation starts it is advised that the thermostat is checked to ensure the insulation resistance reading is above $2M\Omega$ at no less than 500 volts dc.
- Should the thermostat fail this test, isolate the power or control circuits (if installed), and follow the steps below:
 - Fill the terminal box with silica gel bags and replace the terminal box lid.
 - Leave for 24hrs to draw any moisture out of the thermostat.
 - If the insulation resistance has not been raised to a sufficient level after 24hrs, repeat the process above with replacement gel bags.
 - Should the above not raise the insulation resistance to the required level please contact the technical help as per section 1 or via our website:
www.exheat-industrial.com/contact/support

Compliance with these instructions is a warranty requirement. Documented evidence must be maintained in the form of a signed checklist. Copies of completed checklists and records will be required in the event of any warranty claim.

Insulation Resistance Tester

- An insulation resistance tester should be connected between the phase(s) and earth. A reading of greater than $2M\Omega$ at no less than 500 volts dc should be recorded.

5. Installation Instructions



Should deviation from original design parameters occur, or change of original design structure be required, please contact EXHEAT Industrial Ltd for consultation prior to installation.

- Refer to the relevant standards for the equipment provided:
 - *IEC/EN 60079-14* for selection and installation or the relevant global equivalent.
 - *IEC/EN 60079-17* for inspection and maintenance of electric apparatus for use in potentially explosive atmospheres or the relevant global equivalent.
- Carefully remove the packaging from each product and check for damage. Immediately report any damage to EXHEAT Industrial Ltd (please keep this IOM for future reference).
- Ensure that the product is correctly installed in a suitable location by authorised and competent persons.
- The thermostat should be securely fixed in position using the pre-drilled fixing holes, adhering to the correct orientation if applicable, and all terminal connections checked for tightness before energising.
- Before operating the equipment, have the installation approved by the site authorised person who is responsible to ensure that the installed system is safe for operation.
- Ensure compliance with any instructions and information provided in this manual and on the drawings/certification supplied, also be aware of any additional warnings that may be present on the product on any warning labels.
- The installer and the end user shall ensure that the unit has free and unrestricted air flow to allow natural convection to occur at all times. **DO NOT COVER** the thermostat and do not allow anything to rest on or against it.
- The product shall only be energised within its allowed ambient parameters, please check Section 2 and the certificates for the product ambient temperature range.
- Before energising the product, ensure that the supply conforms to the specified voltage on the products nameplate at a nominal variance of +/- 5% of the specified voltage.



Where conduit is used: A conduit seal is required within 50mm of the conduit entry in either Zone 1, Zone 2 or Division 2 explosive atmospheres.



It is the client's responsibility to ensure that safe systems of work are used by all personnel operating and maintaining the equipment, including testing when 'live'.



If there is any uncertainty about these points, contact EXHEAT Industrial Ltd for advice.



Failure to comply could result in the Hazardous Area Certificate being invalidated.

HFT Electrical Supply Connection

- Refer to wiring diagrams in Section 12.
 - The cable entries (2 off M20x1.5) within the HFT are pre-drilled and pre-tapped. If fitted with temporary plugs. Ensure these are replaced with the correctly certified stopping plugs or cable glands, using a thread compound as detailed within Section 9, or an IP washer to suit the gland / stopping plug.
 - Connections to this thermostat are to be made using 6.3mm 'push on' fully insulated crimps (Live in/Out) and ferrule crimps for the neutral link (2.5mm² twin/4.0mm² single). Also, a ring crimp suitable for an M5 earth stud should be used for the internal and external earth connections.
- No additional cable entries are to be made within the terminal box.
- Cable glands installed to the HFT thermostat are to be Ex d/AEx d or Class 1 Division 1 rated. All cable glands are to be suitable for the rating and size of the supply cables. All glands must not decrease the IIC / Groups A, B, C & D rating of this thermostat. IP washers or suitable thread compound (see spares in Section 9) to be used where applicable. Where conduit is used: A conduit seal is required within 50mm of the conduit entry in either Zone 1, Zone 2 or Division 2 explosive atmospheres.
- Before connection ensure that the supply corresponds with that specified on the nameplate label, and that the sizes and types of cables to be used are suitably rated for the load and temperature of the product.
- Where applicable, each thermostat circuit must be protected by a suitably rated over current device and earth leakage circuit breaker device. See below for earth connection details.
- The covers of the HFT terminal boxes are removed after releasing the 4 off socket head screws (5mm² Hex Allen Key) in the cover. When re-fitting ensure that the O-ring seal is in good condition and correctly located. The main cover mating and spigot faces **MUST** be kept clean and free from any debris at all times.
- After re-fitting the lids and tightening the 4 off socket head screws (Torque 4Nm) on the HFT thermostat, verify with a feeler gauge that the gap between the lid and the enclosure does not exceed 0.15mm max.
- The installer or end user must connect to the EXHEAT Industrial Ltd designated terminals within the terminal box.



WARNING – Silica gel bags must be removed before the thermostat is energised.



WARNING – Check nameplate for correct voltage and classification.

AFT Electrical Supply Connection

- Refer to wiring diagrams in Section 12.
 - The cable entries (2 off M20x1.5) within the AFT are pre-drilled and pre-tapped. If fitted with temporary plugs, ensure these are replaced with the correctly certified stopping plugs, using a thread compound as detailed within Section 9.
 - Connections to this thermostat are to be made using ferrule crimps within a terminal block mounted within the enclosure (4.0mm²). Also, a ring crimp suitable for an M5 earth stud should be used for the internal and external earth connections.
- No additional cable entries are to be made within the terminal box.
- The cable glands installed to the AFT thermostat are to be Ex d rated. All cable glands are to be suitable for the rating and size of the supply cables. All glands must not decrease the IIC & IIIC rating of this thermostat. IP washers or suitable thread compound (see spares in Section 9) to be used where applicable.
- Before connection ensure that the supply corresponds with that specified on the nameplate label, and that the sizes and types of cables to be used are suitably rated for the load and temperature of the product.
- Where applicable, each thermostat circuit must be protected by a suitably rated over current device and earth leakage circuit breaker device. See below for earth connection details.
- The covers of the AFT terminal boxes are removed after releasing the 3 off socket head screws (8mm² Hex Allen Key) in the cover. When re-fitting ensure that the O-ring seal is in good condition and correctly located. The main cover mating and spigot faces **MUST** be kept clean and free from any debris at all times.
- After re-fitting the lids and tightening the 3 off socket head screws (Torque 4Nm) on the AFT thermostat, verify with a feeler gauge that the gap between the lid and the enclosure does not exceed 0.15mm max.
- The installer or end user must connect to the EXHEAT Industrial Ltd designated terminals within the terminal box - **DO NOT** disturb factory fitted wiring, unless you are switching the thermostat to a 'make on rise' connection.



WARNING – Silica gel bags must be removed before the thermostat is energised.



WARNING – Check nameplate for correct voltage and classification.

HFT Earth Connections



WARNING – This thermostat **MUST BE EARTHED**.

- The external earth connection on the HFT range is on the left-hand side (bottom corner) of the terminal box and is made using an M5 pan head screw with proprietary cable ring crimp. See Section 11.
- An internal earth connection is provided inside the terminal box, using an M5 earth post with 8mm nuts and proprietary cable ring crimp. See Section 11.

AFT Earth Connections



WARNING – This thermostat **MUST BE EARTHED**.

- The external earth connection on the AFT range is on the right-hand side (bottom corner) of the terminal box and is made using an M5 pan head screw with proprietary cable ring crimp. See Section 11.
- An internal earth connection is provided inside the terminal box, using the manufacturer installed terminal block and proprietary ferrule crimps (twin 2.5mm² or 4mm²). See Section 11.

Earth-fault Protection

For safety reasons, it is essential to limit the magnitude and duration of earth-fault currents. It is impractical to cover all possible systems, however note that, regardless of which system is used, the product must be protected by a suitable device wired to shut down the product if the thermostat fails to earth. Suitable devices include a residual current device (RCD) – this is the preferred method and should be used whenever possible – or an insulation monitoring device.

- Maximum recommended setting for the RCD: 100mA/10mS. The duration time of 10mS (ten milliseconds) ensures that any fault is detected within a single cycle of a thyristor system (where applicable).
- Maximum recommended setting for the insulation monitoring device: Insulation resistance is not greater than 50 ohms per volt of rated voltage.

Ensure that the equipment is earthed in accordance with the plant earthing philosophy.

Before commissioning the equipment, the completed installation should be approved by an authorised & competent person to ensure that it has been carried out correctly and that the system is safe for commissioning.

Before switching the thermostat circuit on, check that all the relevant requirements, and any special conditions of use have been adhered to, including any additional warning labels that may be present on the product itself.

6. Operating Instructions

General

Electrical equipment must be designed, tested and installed such that, when it is used correctly, health and safety risks are kept to a minimum. The user must be provided with information about any necessary safety conditions, warned of any possible hazards that may arise during normal operation and told how to avoid them.

The user must ensure that the following is adhered to:

- Any employees working on the equipment are authorised & competent in the proper working procedures to ensure safety. The plant must be maintained in a safe condition.
- The thermostat terminal enclosure covers are not removed whilst any precipitation, airborne dust or moisture is in the vicinity or when grinding, welding or similar activities are taking place nearby.
- The thermostat lid is not to be removed when it is energised.
- Ensure that all protective packaging is removed carefully and visually inspect product for any transit damage.
- Thermostats must be handled with care and stored in clean and dry conditions, as per Section 3.
- All prevailing rules, regulations and bylaws in force at the time and place of installation must be observed.
- The thermostat should be securely fixed in position (adhering to the correct orientation if applicable) and all connections checked for tightness before energising.
- Refer to the relevant code of practice for the equipment:
 - IEC/EN 60079-14 for selection and installation or the relevant global equivalent.
 - IEC/EN 60079-17 for inspection and maintenance of electric apparatus for use in potentially explosive atmospheres or the relevant global equivalent.
- Precautions must be taken to prevent damage to machined surfaces and threads of flameproof enclosures.
- For Ex d/AEx d or Class I Division 2 explosion-proof equipment, ensure that the flamepath surfaces are in good condition. Report any damage to EXHEAT Industrial Ltd as flamepaths are not intended to be repaired.
- Ensure that any special conditions of use detailed on the Hazardous Area Certification are complied with (see additional certification booklet supplied with this product).
- Any modification not carried out by EXHEAT Industrial Ltd could invalidate certification and warranty.



CAUTION – There is the potential for electrostatic discharge and as such, painted surfaces should only be cleaned with a damp cloth.

The calorific transfer of sensor shall not transmit, in any case a heating above +80°C, including ambient temperature, to all thermostat parts directly in contact with an explosive atmosphere.

Provided the preceding conditions are adhered to, the equipment is considered safe for use under normal operating conditions.

Safety hazards may arise when authorised and competent persons need to remove covers on equipment to carry out maintenance, testing or setting up to work. In many of these cases the equipment cannot be completely isolated before working on it.

It is virtually impossible to achieve conditions which are completely hazard-free when working on energised circuits. Responsibility for safe conduct of the authorised & competent person or persons operating on the equipment rests with those under whose authority they act.

Operating Instructions (HFT)

- The thermostat is to be used to regulate a temperature, by means of wiring in series with an EXHEAT Industrial Ltd (or other) heater or by wiring as per the individual heaters specific wiring diagram. They can also be wired into the control circuit for a suitably rated contactor to switch multiple heaters with 1 off thermostat.
- To adjust the temperature settings on the HFT thermostat, ensure that there is no hazardous gas or internal hot spots, remove the lid, by unscrewing the 4 off lid fixing screws and rotate the adjustable control knob clockwise to increase the desired set-point or anti-clockwise to reduce the set-point. ****NOTE**** Please set the temperature required by turning the thermostat control adjuster to a higher temperature than you require, then anti-clockwise back to the temperature that you require. Should you be decreasing the temperature only, there is no need to turn clockwise first.
- When re-fitting the enclosure lid ensure that the O-ring seal is in good condition and correctly located.
- After re-fitting the lids and tightening the 4 off socket head screws (Torqued to 4Nm) on the HFT thermostat, verify with a feeler gauge that the gap between the lid and the enclosure does not exceed 0.15mm max.
- The SPDT (Single Pole, Double Throw), 20 Amps 250 volts AC thermostat gives a choice of switching configuration (make on rise or break on rise).
- The HFT range is designed to operate within an ambient temperature range, the user must ensure that the minimum and maximum ambient temperatures are not exceeded at any time. **Please refer to sections 2 and 8.**



CAUTION – Check that the voltage and current of the product to be controlled by the thermostat is compatible with the ratings of the thermostat before energising.

Operating Instructions (AFT)

- The thermostat is to be used to regulate a temperature, by means of wiring in series with an EXHEAT Industrial Ltd (or other) heater or by wiring as per the individual heaters specific wiring diagram. They can also be wired into the control circuit for a suitably rated contactor to switch multiple heaters with 1 off thermostat.
- To adjust the temperature settings on the AFT thermostat, simply rotate the adjustable control knob clockwise to increase the desired set-point or anti-clockwise to reduce the set-point (this can be done using a large screwdriver). Please set the temperature required by turning the thermostat control adjuster to a higher temperature than you require, then anti-clockwise back to the temperature that you require. Should you be decreasing the temperature only, there is no need to turn clockwise first.
- The SPDT (Single Pole, Double Throw), 20 Amps 250 volts AC thermostat gives a choice of switching configuration (make on rise or break on rise).
- When re-fitting the enclosure lid ensure that the O-ring seal is in good condition and correctly located.
- After re-fitting the lids and tightening the 3 off socket head screws (to 4Nm) on the AFT thermostat, verify with a feeler gauge that the gap between the lid and the enclosure does not exceed 0.15mm max.
- The AFT range is designed to operate within an ambient temperature range, the user must ensure that the minimum and maximum ambient temperature are not exceeded at any time. **Please refer to sections 2 and 8.**



CAUTION – Check that the voltage and current of the product to be controlled by the thermostat is compatible with the ratings of the thermostat before energising.

7. Maintenance Instructions

General Safety Precautions

The user must ensure that maintenance, installations, commissioning and testing of the equipment is only carried out by authorised and competent persons.

The following rules must be adhered to:

- All prevailing site safety regulations shall be adhered to at all times.
- Check for hazardous gas and dust before and during any maintenance activity.
- Fully isolate the equipment from the electrical supply before and whilst any work is being performed.
- Before starting maintenance work, isolate the equipment completely where possible.
- Before removing the terminal enclosure, allow sufficient time for the internal components to cool down after electrical isolation.
- Do not work alone on the equipment when it is energised.
- Be aware of hazards which may arise when working on energised equipment, and take all necessary precautions.
- Familiarise all persons working on the equipment with the instructions and information provided within this manual.

The following preventative maintenance should be carried out at the recommended intervals shown below, for any replacement parts, please contact EXHEAT Industrial Ltd.

Compliance with these maintenance instructions is a mandatory requirement. Documented evidence must be maintained in the form of a signed checklist. Copies of completed checklists and records will be required in the event of a warranty claim.



If thermostats are not used for more than three months, they must be tested for insulation resistance before being energised.

The following recommended inspections are applicable to both the AFT and the HFT type thermostats:

Three-monthly Maintenance Inspections

- Generally, inspect the equipment for external damage or signs of deterioration.
- Ensure that the product is clear of obstruction and that the airflow remains unrestricted.

Six-monthly Maintenance Inspections

The following should be undertaken every six months in addition to the three-monthly maintenance inspections above:



Do not remove the terminal enclosure cover during wet or humid conditions as this could lead to a reduction in insulation resistance of the thermostat.

- Isolate the electrical supply and remove the cover as per Section 5.
- Internals should be clean, dry and free from debris.
- Ensure that electrical terminations are undamaged and secure.
- Measure the overall insulation resistance of the thermostat. Use a 500V dc Insulation Resistance Tester to take a reading between the earth and the phase terminals. The reading should be greater than 2 megohm. If it is not, refer to Section 4.
- Ensure that the O-ring is in good condition and replace if required. Carefully refit the cover using only and all of, the socket head screws provided, as per Section 5.
- Check the torque of the lid fixings and the flamepath gap on the AFT/HFT thermostat, as per Section 5.
- Earth continuity must be maintained between all earth points and the main structure, ensure that any earth conductors are correctly and securely fitted between all earth points and main structure.
- Ensure all trip devices are working properly.



For Ex d/AEx d or Class I Division 2 explosion-proof equipment, ensure that the flamepath surfaces are in good condition. Report any damage to EXHEAT Industrial Ltd as flamepaths are not intended to be repaired.

Annual Inspections and Long-Term Storage Inspections

Ensure that the following inspections are carried out if equipment is in storage or in use for a year or more:

- Maintain preservation as per Section 3.
- Undertake the three monthly and six-monthly inspections as above.
- Inspect for low insulation resistance, as Section 4.
- EXHEAT Industrial Ltd would strongly recommend that any replacements for this hazardous area equipment be purchased through our sales team, any unauthorised modifications could invalidate the hazardous area certification and any warranty.

- If equipment is being left unused for a period greater than three months, undertake the 6-monthly maintenance before energising.
- Check for component failure in line with Section 4, if there is component failure or low insulation resistance, contact EXHEAT Industrial Ltd for further advice.



Only EXHEAT Industrial Ltd or approved Services Representative are authorised to replace thermostat related components. The hazardous area certification and warranty could be invalidated if this requirement is not strictly observed.

8. Special Conditions of Use

There are several warnings within this IOM for the AFT/HFT thermostats that need to be adhered to. Additionally, the following conditions are what is listed within the AFT/HFT certificates and need to be adhered to for the safe use of our thermostats.

- All unused cable entries shall be suitably fitted with a suitably certified blanking elements/stopping plugs. The blanking elements/stopping plugs shall have a certification coding, temperature class, service temperatures (for non-metallic materials), and ingress protection suitable for use with the equipment.
- The enclosures surface is non-conducting and may generate an ignition-capable level of electrostatic charge under certain extreme conditions. The user shall ensure that the equipment shall not be used in a location where the external conditions are conducive to the build-up of electrostatic charge on non-conductive surfaces. Additionally, the equipment shall only be cleaned with a damp cloth.
- Special Fasteners shall have a yield strength of at least 450 N/mm³ and shall be of a grade A4-70 as minimum for the HFT series.
- Special Fasteners shall have a yield strength of at least 1100 N/mm³ and shall be of a grade 12.9 as minimum for the AFT series.
- The thermostat is intended to regulate the temperature of devices and hence can be considered as a safety related device. The function of this safety related device is not considered under this certification and should be considered as part of the overall assembly/installation.
- Ensure that any additional warnings not within this IOM but placed on the product are adhered to.

9. Fault Finding, Correction and Spares

All Thermostats

See Maintenance instructions for procedures relating to these faults.

Fault	Check	Resolution
Room/Cabinet fails to achieve required design air temperature	<ul style="list-style-type: none"> Isolated power supply. Supply fuses. Is the thermostat in a 'closed' state Is the ambient temperature greater than that required (thermostat has turned off)? The designed heating output is less than the required amount. 	<p>Contact the installer.</p> <p>Contact EXHEAT Industrial Ltd for advice.</p>
Air temperature too high	<ul style="list-style-type: none"> Temperature control device set points correct. Does the thermostat switch the heating equipment correctly? 	Check with the installer.
Earth leakage trip	<p>Limiting earth-fault currents (magnitude and/or duration) is essential for safety.</p> <p>The earth-fault protection device is intended to provide critical safety protection if there is current leakage to earth. Fully investigate and rectify any trip condition before resetting the system and operating the unit again.</p>	<p>Where an earth leakage trip has occurred, isolate the unit and:</p> <ul style="list-style-type: none"> Check insulation resistance is according to Section 4. Check settings of earth leakage protection device are according to Section 5.

Spares All Thermostats

The Spares available for this product are as follows:

Failure Type	Meantime Between Failures	Estimated Replacement Time	Spares Lead Time
Thermostat	30,000 cycles	1 hour	2 weeks
Thermostat retaining circlip	Possibly if thermostat is replaced	5 minutes	2 weeks
Replacement Silica Gel bags (when in storage or prior to being energised)	When Required	5 minutes	2 weeks
O-ring for lid seal	When Required	5 minutes	2 weeks
Replacement Lid Fasteners HFT: Min Yield Strength 450N/mm ² Grade A4-70 AFT: Min Yield Strength 1100N/mm ² Grade 12.9 (HFT x 4 off and AFT x 3 off)	When Required	5 minutes	2 weeks
Compound for threaded entries (Hylomar PL32)	Consumable	Varies	2 weeks

10. COSHH Statement

Health and Safety Information

There are no hazardous or toxic substances applied with this order as defined in COSHH (control of substances hazardous to health) regulations (2002).

11. General Arrangement Drawings

HFT TYPE THERMOSTAT GENERAL ARRANGEMENT

VIEW WITH TERMINAL BOX LID REMOVED

SIDE VIEW WITH TERMINAL BOX LID REMOVED

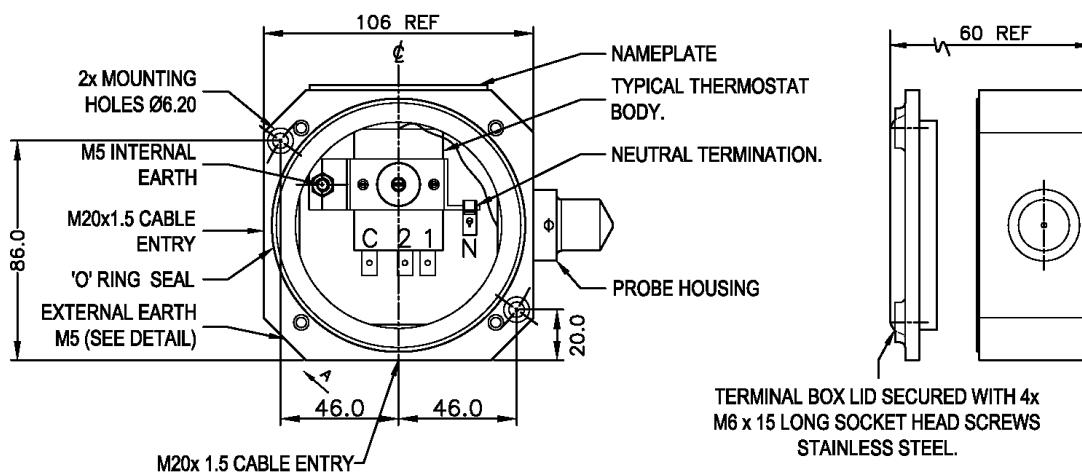

VIEW IN DIRECTION 'A' SHOWING EXTERNAL EARTH.

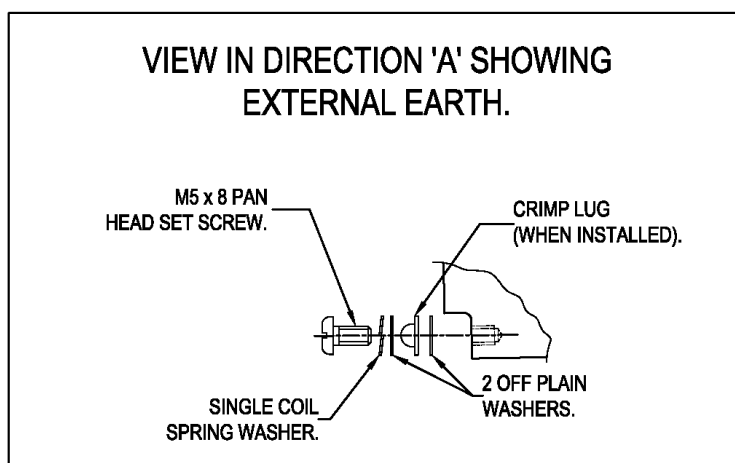

AFT TYPE THERMOSTAT GENERAL ARRANGEMENT

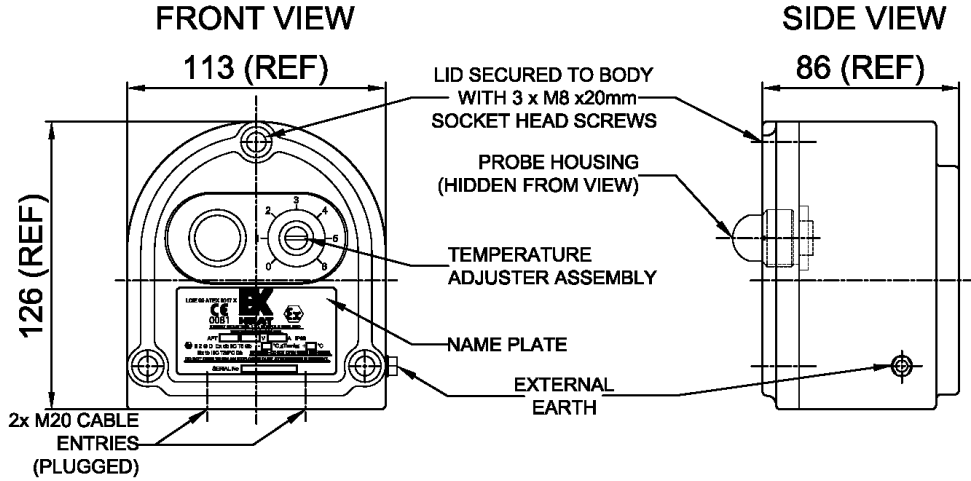

TERMINAL BOX AND BOX LID FRONT VIEW (WITH LID REMOVED) SHOWING TERMINAL BLOCK ASSEMBLY, FIXING HOLES AND THERMOSTAT POSITION

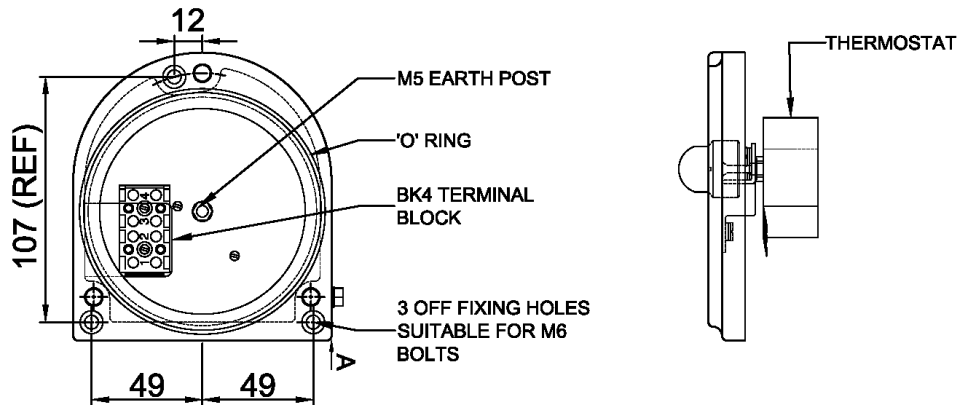

VIEW IN DIRECTION 'A' SHOWING EXTERNAL EARTH.

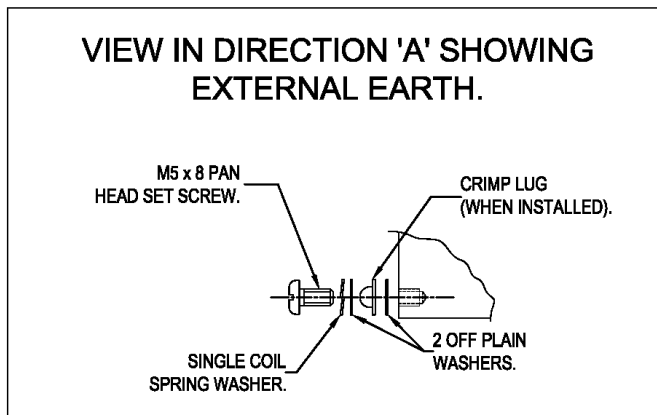

12. Wiring Diagrams

HFT THERMOSTAT SCHEMATIC

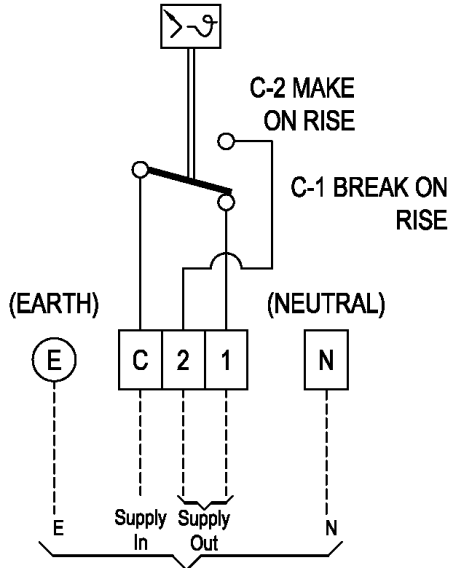

CLIENT CONNECTIONS INC.
NEUTRAL LINK TERMINAL

HFT THERMOSTAT INTERNAL LAYOUT

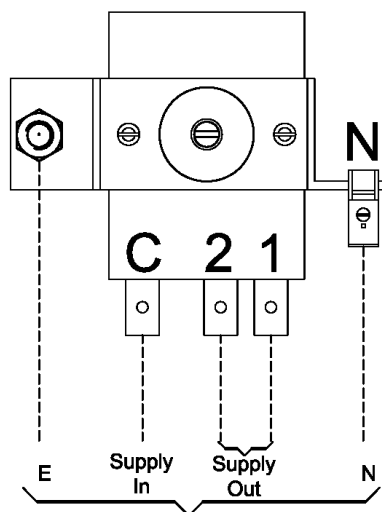

CLIENT CONNECTIONS
INC. NEUTRAL LINK
TERMINAL

AFT THERMOSTAT SCHEMATIC

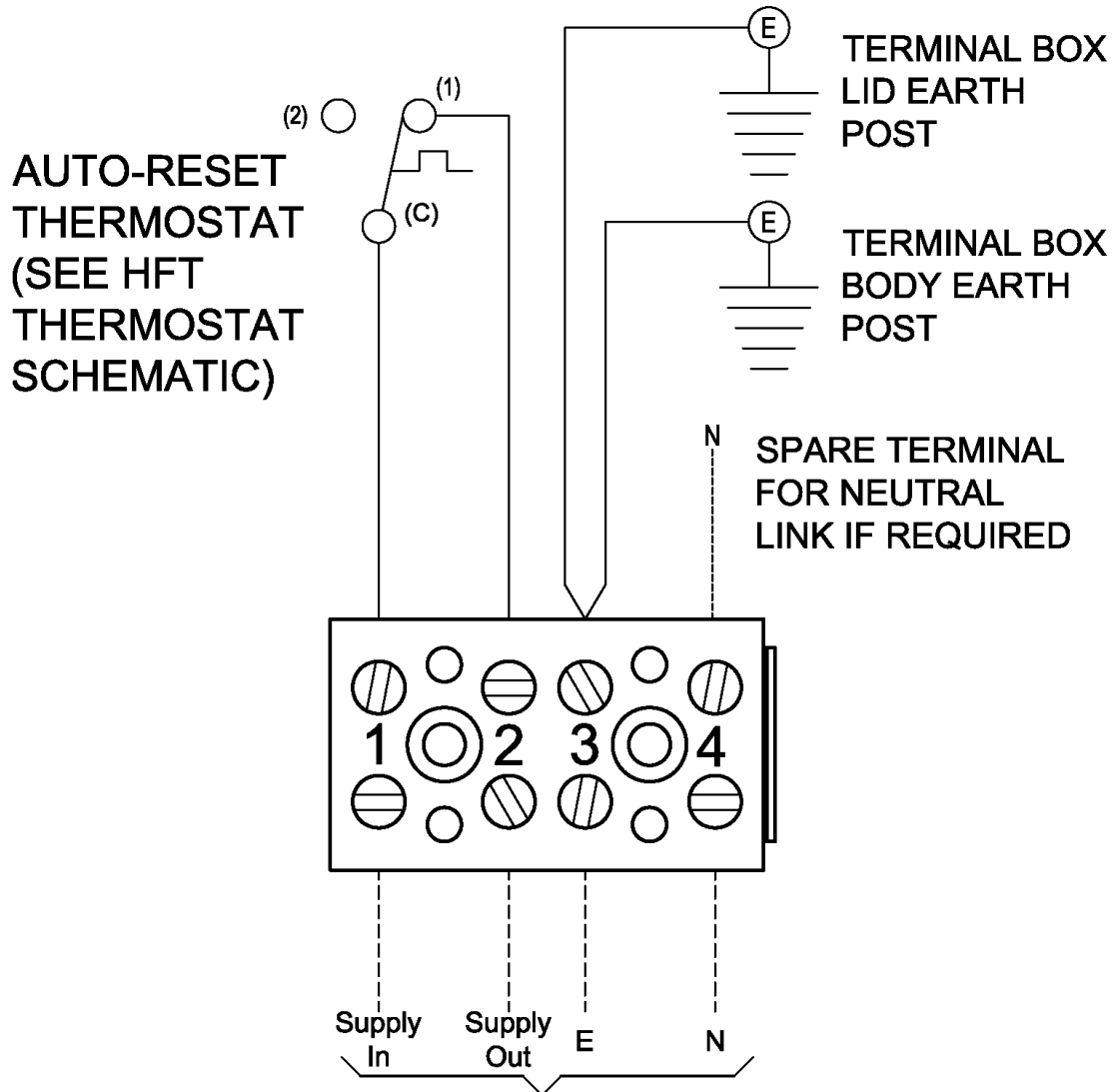

**CLIENT CONNECTIONS INC.
NEUTRAL LINK TERMINAL**

13. Routine Maintenance Inspection Record

EXHEAT Industrial Ltd
Threxton House
Threxton Road Ind. Est.
Watton, Thetford, Norfolk
IP25 6NG, United Kingdom
Tel: +44 (0) 1953 886 269
Fax: +44 (0) 1953 883 853
www.exheat-industrial.com

ROUTINE MAINTENANCE INSPECTION RECORD

AFT/HFT Thermostat



Serial No					
Description					
PO No					
Reference No					
Inspection Checklist	Status Codes	Name	Date	Comment	
	<u>3 Monthly Inspection</u>				
a	Check equipment for external damage or signs of deterioration				
b	Check for dust build up or restricted air flow and clean				
	<u>6 Monthly Inspection (in addition to 3 Monthly Inspection)</u>				
c	Check that there is no dirt, debris, loose items or moisture within the terminal enclosure				
d	Check that all electrical connections are undamaged and tight including any spare unused terminals.				
e	Check the thermostats insulation resistance				
f	Check that enclosure gaskets or O-rings are undamaged and fitted correctly				
g	Check flamepaths are undamaged				
h	Check that earth conductors are correctly fitted and undamaged				
i	Check that the thermostat enclosure covers are closed, and all fasteners are fitted, tight with correct torque (see Section 5) and of the correct type				
j	Check all trip devices are set and functioning correctly				
	<u>12 Monthly Inspection (in addition to 3 & 6 Monthly Inspections)</u>				
k	Check resistance values				
<i>Carry out the inspection in accordance with relevant standards concerning inspection and maintenance of electrical installations in non-hazardous or hazardous areas whichever is applicable.</i>					
Verified	Installation	Energised		EXHEAT Industrial Ltd	
Name					
Signature					
Date					

Document: Inspection Check List – AFT/HFT

14. Certification Documentation



www.exheat-industrial.com

© Copyright EXHEAT® Industrial Ltd

3rd Edition (April 2019)

Author: P. Bumstead

AFT/HFT – IOM_ENGLISH

Refer to EXHEAT Industrial Ltd website for latest edition.

www.exheat-industrial.com/product



SCATTERGOOD & JOHNSON LTD

ELECTRICAL ENGINEERING & FLUID CONTROL DISTRIBUTORS

Est.1899

At Scattergood & Johnson Ltd, we pride ourselves on being a technical distributor to specialist industries.

Working with a range of quality product suppliers across a number of specialist markets, we are not your average 'box shifter' - we are your technical and supply chain partner.

We fully support every product we sell - for free! Our internal team and external sales engineers can answer any product or application question, no matter the complexity.

Backing up this technical ability is a range of 50,000+ products available from stock for nationwide next day delivery (same day if required!), or you can collect what you need from any of our trade counters around the UK.

Select your specialist interest below to learn more about how we can help.

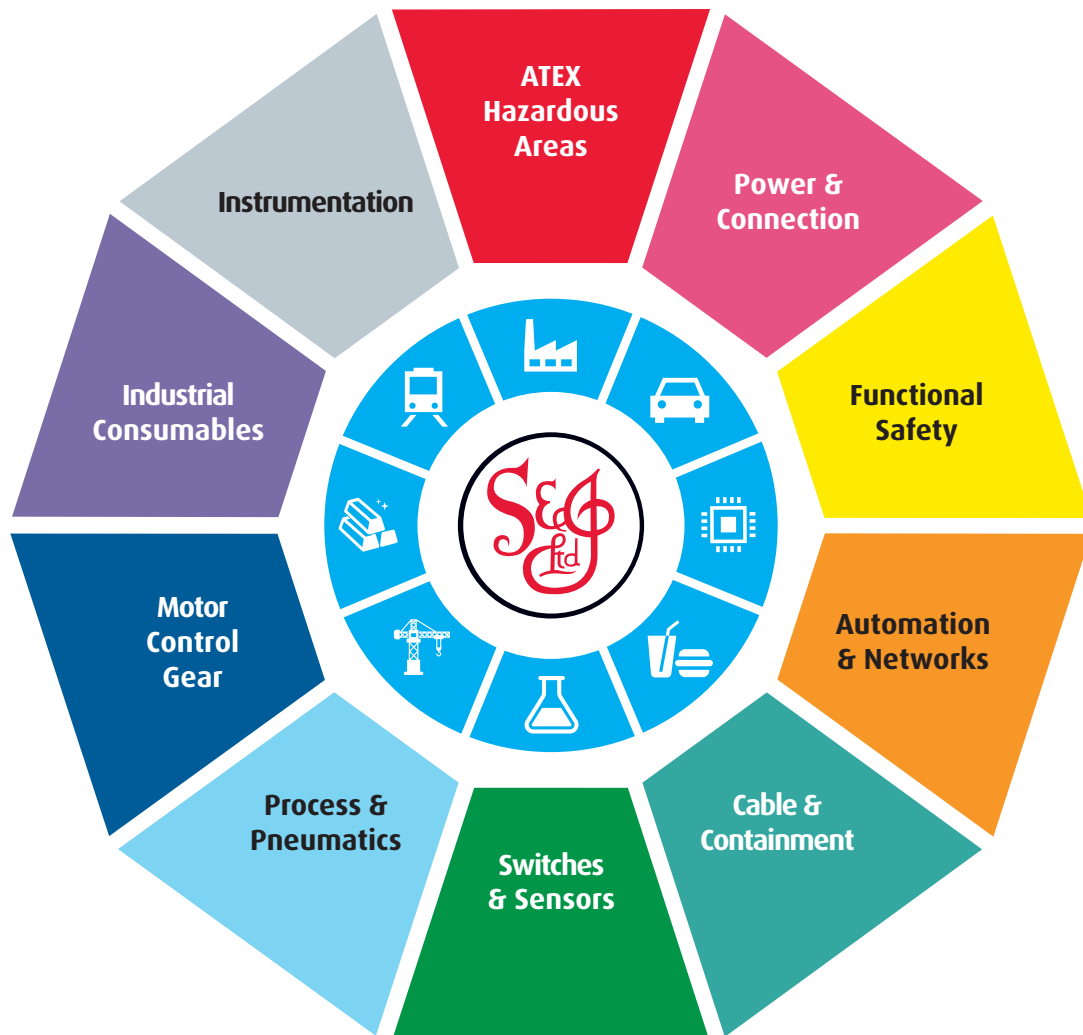

Online, In Branch and On the Road - Scattergood & Johnson Ltd, there when you need us.

www.scatts.co.uk