

DRB240 Series Instruction Manual

ENGLISH

General Safety Instructions:



READ SAFETY INSTRUCTIONS

Servicing:

These products are not customer serviceable TDK-Lambda UK LTD and their authorised agents only are permitted to carry out repairs.

Critical Components:

These products are not authorised for use as critical components in nuclear control systems, life support systems or equipment for use in hazardous environments without the express written approval of the Managing Director of TDK-Lambda EMEA.

Product Usage:

These products are designed for use within a host equipment which restricts access to authorised competent personnel.

This product is a component power supply considered apparatus and is only to be installed by qualified persons within other equipment and must not be operated as a stand-alone product.

This product is for sale to business to business customers and can be obtained via distribution channels.

It is not intended for sale to end users.

This product is considered to be apparatus and complies with the EMC directive. Compliance with the EMC directive must be considered in the final installation. Please contact your local TDK-Lambda office

Environmental:

These products are IPX0, and therefore chemicals/solvents, cleaning agents and other liquids must not be used.

Environment:

This power supply is a switch mode power supply for use in applications within a Pollution Degree 2, overvoltage category II environment. Material Group IIIb PCB's are used within it.

Output Loading:

The output power taken from the power supply must not exceed the rating stated on the power supply label, except as stated in the product limitations in this handbook.

Input Parameters:

This product must be operated within the input parameters stated in the product limitations in this handbook.

End of Life Disposal:

The unit contains components that require special disposal. Make sure that the unit is properly disposed of at the end of its service life and in accordance with local regulations



RISK OF ELECTRIC SHOCK

High Voltage Warning:

Dangerous voltages are present within the power supply. The professional installer must protect service personnel from inadvertent contact with these dangerous voltages in the end equipment.

WARNING: When installed in a Class 1 end equipment, this product must be reliably earthed and professionally installed.

The (+) or (-) output(s) can be earthed or left floating.

The unit cover(s)/chassis (where applicable) must not be made user accessible.

Internal fuses protect the unit and must not be replaced by the user. In case of internal defect, the unit must be returned to TDK-Lambda UK LTD or one of their authorised agents.

A suitable mechanical, electrical and fire enclosure must be provided by the end use equipment for mechanical, electric shock and fire hazard protection.

Energy Hazards:

The main output of this product is capable of providing hazardous energy (240VA). Final equipment manufacturers must provide protection to service personnel against inadvertent contact with the output terminals.

The ventilation openings on these products must not be impeded.

The unit cover/chassis, where applicable, is designed to protect skilled personnel from hazards. They must not be used as part of the external covers of any equipment where they may be accessible to operators, since under full load conditions, part or parts of the unit chassis may reach temperatures in excess of those considered safe for operator access.

Allgemeine Sicherheitsvorschriften:



LESEN SIE DIE SICHERHEITSVORSCHRIFTEN

Wartung:

Diese Produkte können nicht durch den Kunden gewartet werden. Nur TDK-Lambda UK LTD. und deren zugelassene Vertriebshändler sind zur Durchführung von Reparaturen berechtigt.

Kritische Komponenten:

Diese Produkte sind nicht für die Verwendung als kritische Komponenten in nuklearen Kontrollsystemen, Lebenserhaltungssystemen oder Geräten in gefährlichen Umgebungen geeignet, sofern dies nicht ausdrücklich und in Schriftform durch den Geschäftsführer von TDK-Lambda EMEA genehmigt wurde.

Produktverwendung:

Diese Produkte sind zur Verwendung innerhalb von Host-Anlagen gedacht, die einen auf das Fachpersonal beschränkten Zugang haben.

Dieses Produkt ist als eine Stromversorgungs-Baugruppe / Stromversorgungs-Einheit zu betrachten und es darf nur von qualifiziertem Personal in andere Geräte eingebaut werden und es darf NICHT als eigenständiges Gerät ("Stand-Alone") betrieben werden.

Dieses Produkt ist für den Verkauf an Geschäftskunden entwickelt worden und es kann über Distributionskanäle bezogen werden.

Es ist NICHT für den Verkauf an Endkunden gedacht und konzipiert.

Dieses Produkt ist als Gerät zu betrachten and entspricht der EMV Direktive. Die Konformität mit der EMV Direktive muss in der finalen Installation betrachtet werden. Bitte kontaktieren Sie Ihr regionales TDK-Lambda Vertriebsbüro bei Rückfragen

Umwelt:

Diese Produkte sind IPX0, aus diesem Grund dürfen keine Chemikalien/Lösungsmittel, Reinigungsmittel und andere Flüssigkeiten verwendet werden.

Umgebung:

Dieses Netzteil ist ein Schaltnetzteil zur Verwendung in einer Umgebung mit einem Verschmutzungsgrad 2, Überspannungskategorie II. Materialgruppe IIIb mit darin verwendeten PCBs.

Ausgangsstrom:

Der Ausgangsstrom des Netztesiles darf die Leistung, die auf dem Label des Netztesiles vermerkt ist, nur dann überschreiten, wenn dies in den Produktgrenzen dieses Handbuches ausgezeichnet ist.

Eingangsparameter:

Dieses Produkt muss innerhalb der Eingangsparameter, die in den Produktgrenzen dieses Handbuches angegeben sind, betrieben werden.

Entsorgung am Ende der Betriebszeit:

Das Gerät enthält Komponenten die unter Sondermüll fallen. Das Gerät muss am Ende der Betriebszeit ordnungsgemäß und in Übereinstimmung mit den regionalen Bestimmungen entsorgt werden.



GEFAHR DURCH ELEKTRISCHEN SCHLAG

Hochspannungswarnung:

Innerhalb des Netzteiles gibt es gefährliche Spannungen. Der Elektroinstallateur muss das Wartungspersonal vor versehentlichem Kontakt mit den gefährlichen Spannungen im Endgerät schützen.

WARNUNG! Falls Sie unser Netzgerät in eine Anwendung mit Schutzklasse 1 eingebaut haben, stellen Sie sicher, dass es fachgerecht installiert und zuverlässig geerdet ist.

Die (+) oder (-) Ausgänge können geerdet werden oder unangeschlossen bleiben.

Die Abdeckung des Gerätes/das Gehäuse darf für den Benutzer nicht zugänglich sein.

Eine interne Sicherung schützt das Gerät und darf durch den Benutzer nicht ausgetauscht werden. Im Fall von internen Defekten muss das Gerät an TDK-Lambda UK LTD oder einen der autorisierten Vertriebshändler zurückgeschickt werden.

Ein geeignetes mechanisches, elektrisches und brandgeschütztes Gehäuse muss als Schutz vor der Gefahr von mechanischen Risiken, Stromschlägen und Brandschutz in dem Endgerät vorgesehen werden.

Gefahren durch elektrische Energie:

Der Ausgang/die Ausgänge dieses Netzteiles ist/sind gefährlich energie (240VA) und dürfen in dem Endgerät, in das sie installiert werden, nicht für den Benutzer zugänglich sein.

Die Belüftungsöffnungen an diesem Produkt dürfen nicht blockiert werden.

Die Geräteabdeckung/das Gehäuse ist so entworfen, dass das Fachpersonal vor Gefahren geschützt wird. Sie dürfen nicht als Teil der externen Abdeckung für Geräte verwendet werden, die für den Betreiber zugänglich sein müssen, da Teile oder das gesamte Gerätegehäuse unter voller Auslastung übermäßige Temperaturen erreichen kann, die für den Zugang des Betreibers nicht mehr als sicher betrachtet werden.

Consignes générales de sécurité:



LIRE LES CONSIGNES DE SECURITE

Entretien:

Ces produits ne peuvent pas être réparés par l'utilisateur. Seuls, TDK-Lambda UK LTD et ses agents agréés sont autorisés à effectuer des réparations.

Composants critiques:

Ces produits ne doivent pas être utilisés en tant que composants critiques dans des systèmes de commande nucléaire, dans des systèmes de sauvetage ou dans des équipements utilisés dans des environnements dangereux, sans l'autorisation écrite expresse du directeur général de TDK-Lambda EMEA.

Utilisation du produit:

Ces produits sont conçus pour être utilisés dans un équipement hôte dont l'accès n'est autorisé qu'aux personnes compétentes.

Ce produit est une alimentation considérée comme un appareil devant être installé par des personnes qualifiées, dans un autre équipement. Il ne doit pas être utilisé en tant que produit fini.

Ce produit est destiné à la vente entre entreprises et peut être obtenu via des canaux de distribution.

Il n'est pas prévu à la vente pour les particuliers.

Ce produit considéré comme un appareil conforme à la directive CEM. Le respect de la directive CEM doit être pris en compte dans l'installation finale. Veuillez contacter votre bureau TDK-Lambda le plus proche.

Environnement:

Ces produits sont IPX0, et donc on ne doit pas utiliser des produits chimiques/solvants, des produits de nettoyage et d'autres liquides.

Environnement fonctionnel :

Cette alimentation fonctionne en mode commutation pour utilisation dans des applications fonctionnant dans un environnement avec Degré de Pollution 2 et catégorie de surtension II. Elle utilise des cartes des circuits imprimés (PCB) de Groupe IIIb.

Intensité soutirée:

L'intensité soutirée de l'alimentation ne doit pas dépasser l'intensité nominale marquée sur la plaque signalétique, sauf indications contraires dans les limitations du produit décrit dans ce manuel.

Paramètres d'entrée:

Ce produit doit être utilisé à l'intérieur des paramètres d'entrée indiqués dans les limitations du produit dans ce manuel.

Elimination en fin de vie:

L'alimentation contient des composants nécessitant des dispositions spéciales pour leur élimination. Vérifiez que cette alimentation est mise au rebut correctement en fin de vie utile et conformément aux réglementations locales en vigueur.



RISQUE DE CHOC ELECTRIQUE

Attention-Danger haute tension :

Des tensions dangereuses sont présentes dans l'alimentation. L'installateur doit protéger le personnel d'entretien contre un contact involontaire avec ces tensions dangereuses dans l'équipement final.

AVERTISSEMENT: Si ce produit est installé dans un équipement final de classe I, il doit être mis à la terre de manière fiable et installé par un professionnel averti.

Les sorties (+) ou (-) peuvent être raccordées à la terre ou laissées flottantes.

Le couvercle/châssis de l'alimentation ne doit pas être accessible à l'utilisateur.

Un fusible interne protège le module et ne doit pas être remplacé par l'utilisateur. En cas de défaut interne, le module doit être renvoyé à TDK-Lambda UK LTD ou l'un de ses agents agréés.

Une enceinte appropriée doit être prévue par l'utilisateur final pour assurer la protection contre les chocs mécaniques, les chocs électriques et l'incendie.

Energies dangereuses :

Les sorties de cette alimentation sont dangereuses énergie (240VA) et ne doivent pas être accessibles dans l'équipement final dans lequel elle est installée.

Les orifices de ventilation sur ces produits ne doivent pas être obstrués.

Le couvercle et le châssis du module sont conçus pour protéger des personnels expérimentés. Ils ne doivent pas être utilisés comme couvercles extérieurs d'un équipement, accessible aux opérateurs car en condition de puissance maximum, des parties du châssis peuvent atteindre des températures considérées comme dangereuses pour l'opérateur.

Norme generali di sicurezza:



SI PREGA DI LEGGERE LE NORME DI SICUREZZA

Manutenzione:

Il cliente non può eseguire alcuna manutenzione su questi prodotti. L'esecuzione delle eventuali riparazioni è consentita solo a TDK-Lambda UK LTD e ai suoi agenti autorizzati.

Componenti critici:

Non si autorizza l'uso di questi prodotti come componenti critici all'interno di sistemi di controllo nucleari, sistemi necessari alla sopravvivenza o apparecchiature destinate all'impiego in ambienti pericolosi, senza l'esplicita approvazione scritta dell'Amministratore Delegato di TDK-Lambda EMEA.

Uso dei prodotti:

Questi prodotti sono progettati per l'uso all'interno di un'apparecchiatura ospite che limiti l'accesso al solo personale competente e autorizzato.

Questo prodotto è un alimentatore professionale componente considerato apparato e come tale deve essere installato da qualificato personale all'interno di altre apparecchiature e non deve essere utilizzato come prodotto indipendente.

Questo prodotto è vendibile solo ad utilizzatori e compratori professionali, attraverso i vari canali di distribuzione.

Questo prodotto non è inteso per la vendita al dettaglio o agli utilizzatori finali.

Questo prodotto è da considerarsi come apparato e conforme con la direttiva EMC. Conformità alla direttiva EMC deve essere considerata nell'installazione finale. Gli uffici di TDK-Lambda Sas Succursale Italiana sono a vostra disposizione per ulteriori ragguagli.

Condizioni ambientali:

Questi prodotti sono classificati come IPX0, dunque non devono essere utilizzati sostanze chimiche/solventi, prodotti per la pulizia o liquidi di altra natura.

Ambiente:

Questo prodotto è un alimentatore a commutazione, destinato all'uso in applicazioni rientranti in ambienti con le seguenti caratteristiche: Livello inquinamento 2, Categoria sovratensione II. Questo prodotto contiene schede di circuiti stampati in materiali di Gruppo IIIb.

Carico in uscita:

La potenza in uscita ottenuta dall'alimentatore non deve superare la potenza nominale indicata sulla targhetta dell'alimentatore, fatto salvo dove indicato nei limiti per il prodotto specificati in questo manuale.

Parametri di alimentazione:

Questo prodotto deve essere utilizzato entro i parametri di alimentazione indicati nei limiti per il prodotto, specificati in questo manuale.

Smaltimento:

L'unità contiene componenti che richiedono procedure speciali di smaltimento. Accertarsi che l'unità venga smaltita in modo corretto al termine della vita utile e nel rispetto delle normative locali.



RISCHIO DI SCOSSA ELETTRICA

Avvertimento di alta tensione:

All'interno dell'alimentatore sono presenti tensioni pericolose. Gli installatori professionali devono proteggere il personale di manutenzione dal rischio di contatto accidentale con queste tensioni pericolose all'interno dell'apparecchiatura finale.

ATTENZIONE: Se installato in un'attrezzatura di classe I, questo prodotto deve essere collegato a terra in modo affidabile ed installato in modo professionale.

Le uscite (+) o (-) possono essere messa a terra o lasciate isolate.

I coperchi/il telaio dell'unità non devono essere accessibili da parte dell'utente.

Un fusibile interno protegge l'unità e non deve essere sostituito dall'utente. Nell'eventualità di un difetto interno, restituire l'unità a TDK-Lambda UK LTD o a uno dei suoi agenti autorizzati.

L'apparecchiatura finale deve includere una recinzione meccanica, elettrica e antincendio per proteggere dai pericoli di natura meccanica, dalle scosse elettriche e dai pericoli di incendio.

Pericoli energetici:

Le uscite generate da questo alimentatore sono energia pericolose (240VA) e non devono risultare accessibili da parte dell'utente all'interno dell'apparecchiatura finale in cui il prodotto viene installato.

Le griglie di ventilazione su questi prodotti non devono essere ostruite.

Il coperchio/telaio dell'unità è realizzato per proteggere il personale esperto dai pericoli. Non deve essere usato come parte degli involucri esterni di qualsiasi apparecchiatura, se risulta accessibile da parte degli addetti, poiché è possibile che in condizioni di pieno carico una o più parti del telaio dell'unità giunga/giungano a temperature superiori ai limiti considerati sicuri per l'accesso da parte degli addetti.

Instrucciones generales de seguridad:



LEA LAS INSTRUCCIONES DE SEGURIDAD

Servicio:

Estos productos no pueden ser reparados por los clientes. TDK-Lambda UK LTD. y sus agentes autorizados son los únicos que pueden llevar a cabo las reparaciones.

Componentes fundamentales:

Estos productos no pueden ser utilizados como componentes fundamentales en sistemas de control nuclear, sistemas de soporte vital o equipos a utilizar en entornos peligrosos sin el consentimiento expreso por escrito del Director General de TDK-Lambda EMEA.

Uso de los productos:

Estos productos han sido diseñados para ser utilizados en un equipo central que restrinja el acceso al personal cualificado autorizado.

Este producto es un aparato considerado fuente de alimentación y sólo para ser instalado por personas cualificadas dentro de otros equipos y no debe ser operado como un producto independiente .

Este producto está a la venta entre profesionales y se puede obtener a través de los canales de distribución .

No está destinado para la venta a los usuarios finales .

Este producto es considerado un producto electrónico y cumple con la directiva EMC. Dicho cumplimiento debe ser considerado sobre la instalación final. Por favor, contacte con su oficina o distribuidor local de TDK-Lambda

Medioambiental:

Estos productos son IPX0 y, por tanto, no pueden utilizarse sustancias químicas/disolventes, agentes de limpieza ni otros líquidos.

Medio ambiente:

Esta fuente de alimentación es una fuente de alimentación de modo conmutado a utilizar en aplicaciones dentro de un entorno con un Grado de contaminación 2 y una Categoría de sobretensión II. En él se utilizan policloruros de bifenilo del Grupo de materiales IIIb.

Carga de salida:

La potencia de salida tomada de la fuente de alimentación no puede sobrepasar el valor nominal indicado en la etiqueta de la fuente de alimentación, excepto en los casos indicados en las limitaciones del producto en este manual.

Parámetros de entrada:

Este producto debe ser utilizado dentro de los parámetros de entrada indicados en las limitaciones del producto en este manual.

Desecho de la unidad:

La unidad contiene componentes que deben ser desechados de una manera especial. Asegúrese de desechar correctamente la unidad al final de su vida útil y conforme a las normas locales vigentes

**PELIGRO DE DESCARGAS ELÉCTRICAS****Advertencia de alta tensión:**

En esta fuente de alimentación hay tensiones peligrosas. El instalador profesional debe proteger al personal de servicio contra cualquier contacto accidental con estas tensiones peligrosas en el equipo final.

ADVERTENCIA: La instalación de este producto en un equipo de clase I la deben llevar a cabo profesionales y el producto debe estar conectado a tierra.

La salida o salidas (+) o (-) pueden conectarse a tierra o se las puede dejar flotando.

Debe impedirse el acceso de los usuarios a la cubierta o cubiertas y al chasis de la unidad.

Un fusible interno protege la unidad y este no debe ser nunca reemplazado por el usuario. En caso de existir algún defecto interno, la unidad debe ser enviada a TDK-Lambda UK LTD o a uno de sus agentes autorizados.

El equipo de uso final debe constituir un recinto de protección mecánica, eléctrica y contra incendios de protección mecánica, contra descargas eléctricas y contra el peligro de incendios.

Peligros de energía:

La salida/salidas de esta fuente de alimentación es/son energía peligrosas energía (240VA) por lo que debe protegerse el equipo final en el que se instalen contra el acceso de los usuarios.

Las aberturas de ventilación de estos productos no deben obstruirse jamás.

La cubierta/chasis de la unidad ha sido diseñada para que proteja a las personas cualificadas de los peligros. No deben ser utilizadas como parte de las cubiertas externas de cualquier equipo al que pueden acceder los operarios, ya que bajo unas condiciones de carga completa, la pieza o piezas del chasis de la unidad pueden alcanzar temperaturas superiores a las consideradas seguras para el acceso de los operarios.

Instruções gerais de segurança:



LEIA AS INSTRUÇÕES DE SEGURANÇA

Manutenção:

Estes produtos não são podem ser submetidos a manutenção por parte do cliente. Apenas a TDK-Lambda UK LTD e os seus agentes autorizados têm permissão para realizar reparações.

Componentes essenciais:

Não é autorizada a utilização destes produtos como componentes essenciais de sistemas de controlo nuclear, sistemas de suporte de vida ou equipamento para utilização em ambientes perigosos sem a expressa autorização por escrito do Director-Geral da TDK-Lambda EMEA.

Utilização do produto:

Estes produtos foram concebidos para utilização dentro de um equipamento de alojamento que apenas permita o acesso a pessoal qualificado autorizado.

Este produto é uma alimentação considerado com um aparelho para ser instalado por pessoas qualificadas em outros equipamentos.

Não deve ser usado como um produto acabado.

Este produto é destinado para venda entre as empresas e pode ser obtido através de canais de distribuição.

Não se destina à venda aos particulares.

Este produto considerado com um aparelho de acordo com a directiva CEM.

Conformidade com a directiva CEM devem ser considerados na instalação final.

Entre em contacto com seu escritório TDK-Lambda mais próximo

Ambiental:

Estes produtos são IPX0 e, como tal, não se devem utilizar químicos/solventes, agentes de limpeza e outros líquidos.

Ambiente:

Esta fonte de alimentação é uma fonte de alimentação do modo de comutação para utilização em aplicações com um Nível de Poluição 2 e ambientes da categoria de sobretensão II. São utilizadas placas de circuitos impressos do grupo de materiais IIIb.

Carga de saída:

A potência de saída extraída da fonte de alimentação não deve exceder a classificação assinalada na etiqueta da fonte de alimentação, excepto quando indicado nas limitações do produto neste guia.

Parâmetros de entrada:

Este produto deve ser utilizado dentro dos parâmetros de entrada indicados nas limitações do produto neste guia.

Eliminação no fim de vida:

A unidade contém componentes que necessitam de procedimentos especiais de eliminação. Certifique-se de que a unidade é devidamente eliminada no fim da sua vida útil e que tal é feito em conformidade com os regulamentos locais.



RISCO DE CHOQUE ELÉCTRICO

Aviso de alta tensão:

Estão presentes tensões perigosas dentro da fonte de alimentação. O profissional que realizar a instalação deve proteger o pessoal de assistência contra contactos inadvertidos com estas tensões perigosas do equipamento final.

AVISO: Quando instalado num equipamento de Classe I, este produto deve ser ligado à terra de forma fiável e instalado por um profissional.

As saídas (+) e (-) podem ser ligadas à terra ou deixadas soltas.

O chassis/cobertura(s) da unidade não deve estar acessível ao utilizador.

Existe um fusível interno que protege a unidade e que não deve ser substituído pelo utilizador. Em caso de defeito interno, a unidade deve ser devolvida à TDK-Lambda UK LTD ou a um dos seus agentes autorizados.

O equipamento de utilização final deve fornecer um bastidor com protecção mecânica, eléctrica e contra incêndios adequada.

Perigos de energia:

As saídas desta fonte de alimentação são energy perigosas (240VA) e não devem estar acessíveis ao utilizador no equipamento final no qual estão instaladas.



As aberturas de ventilação destes produtos não devem ser obstruídas.

O chassis/cobertura da unidade está concebido de forma a proteger o pessoal especializado de perigos. Não devem ser utilizados como parte das coberturas externas de qualquer equipamento em que possam estar acessíveis aos operadores, uma vez que em condições de carga máxima, algumas peças do chassis da unidade podem atingir temperaturas superiores às consideradas seguras para o acesso do operador.

BEFORE USING THE POWER SUPPLY UNIT

Pay attention to all warnings and cautions before using the unit. Incorrect usage could lead to an electrical shock, damage to the unit or a fire hazard.

- **Warning Symbols**

CAUTION	
• DO NOT MODIFY OR DISASSEMBLE THE POWER SUPPLY.	
• READ INSTRUCTION MANUAL BEFORE CONNECTING TO MAINS.	
• ELECTRIC SHOCK HAZARDOUS ON THE CONNECTOR SECTION.	

NOTICE:

(1) Installing/Storage Environment

1. Store the product with ambient temperature -40 to $+85$ °C, and relative humidity 5 to 95% (No Dewdrop).
2. Operation under the following conditions could reduce product life and result in damage:
 - (a) Over current
 - (b) Output terminals shorted
 - (c) Out of input voltage range
 - (d) Out of operating temperature range
 - (e) Out of PSU specification

3. Confirm connections to input/output terminals are correct as indicated in the instruction manual.
4. Use the product where the relative humidity is 5 to 95% (No Dewdrop).
5. Avoid places where the product is subjected to direct sun light.
6. Avoid places where the product is subjected to penetration of liquid, foreign substance or corrosive gas.
7. Avoid places subject to shock or vibration.

A device such as a contact breaker may be a vibration source. Set the Power Supply as far as possible from possible sources of shock or vibration.

8. If the Power Supply is used in an area with excessive electronic noise, be sure to separate the Power Supply as far as possible from the noise sources.
9. Don't use the product in the environment with strong electromagnetic field, corrosive gas and conductive substance.

10. Model/type reference: DRB240-XX-1/xyz

(where XX can be 24 or 48 for the output voltage and xyz is optional and can be alphanumeric characters or blank and is for non-safety related information - product ratings unchanged)

Precautions in Using the product:

When the product is used under the circumstance or environment below, ensure adherence to limitations of the ratings and functions.

Also take countermeasures for safety precautions such as fail-safe installations.

1. Under the circumstances or environment which are not described in the instruction manual.
2. For nuclear power control, railway, aircraft, vehicle, incinerator, medical equipment, entertainment equipment, safety device and etc.
3. For applications where death or serious property damage is possible and extensive safety precautions are required.
4. Not to be used with a high inductive power source, as it may cause unstable operation of the power supply.

Note: CE MARKING

CE Marking, when applied to a product covered by this handbook indicates compliance with the following:
 Low Voltage Directive in that it complies with EN60950-1 and EN62368-1.
 EMC Directive
 Restriction of the use of certain Hazardous Substances Directive

2. Terminal Explanation

2-1. DRB240

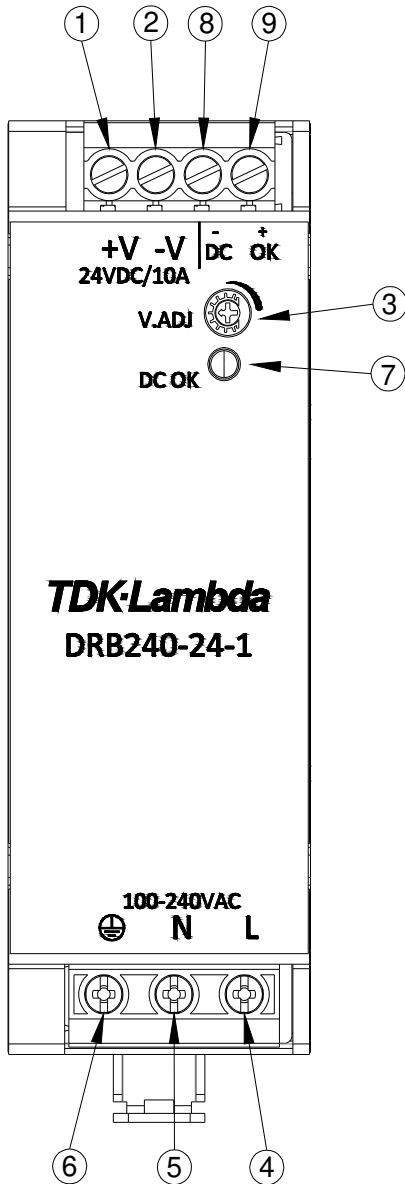

- ① +V: +Output terminal
- ② - V: - Output terminal
- ③ V.ADJ: Output voltage adjust trimmer
The output voltage rises when trimmer is turned clockwise
- ④ L: AC Input terminal
Live line (fuse in line)
- ⑤ N: AC Input terminal
Neutral line
- ⑥ ⊕ : Protective Earth
Connect to safety ground of apparatus or equipment.
- ⑦ DC OK : Green LED lights when Output Voltage is turn on and within specification
- ⑧ - DC : Optocoupler
- ⑨ + OK : Optocoupler

WIRING

Connector	Recommended Wire	Max. Torque
Input (L, N, ⊕)	10~24 AWG	10.3 kgf.cm (9 lbf.in)
Output (+V, -V)	10~24 AWG	10.3 kgf.cm (9 lbf.in)
Output (DC OK)	10~24 AWG	10.3 kgf.cm (9 lbf.in)

Note: According to EN/UL60950-1 multi-strand flexible cables connected to the input require ferrule.

Voltage Variants

Voltage (V)	Voltage Range (V)	Current (A)
24	24 - 28	10 - 8.6
48	48 - 52.8	5 - 4.55

3. Terminal Connecting Method

Pay attention to the input wiring. If it is connected to wrong terminal, the power supply will be damaged.

- Input must be off when making connections.
- Connect \ominus (Protective Earth) terminal of input connector to ground terminal of the equipment.
- The output load line and input line shall be separated and twisted to reduce noise sensitivity.

When connecting or removing input and output wire, do not apply stress to PCB.

4. Explanation of Functions and Precautions

4-1. Input Voltage Range

Input voltage range is single phase 85 ~ 264VAC (47~63Hz) and can withstand 300VAC surge for 5 sec during operation. Input voltage which is out of specification may cause unit to damage. For cases where conformance to various safety specs (UL, CSA, EN) are required, input voltage range will be 100 ~ 240VAC (50/60Hz).

4-2. Output Voltage Range

Output voltage is set to the rated value at shipment. Please see table above for voltages available. V.ADJ trimmer on the front panel side can be used to adjust the output voltage (refer to specifications for adjustable range). To turn the trimmer clockwise, the output voltage will be increased. Take note when the output voltage is increased excessively, over voltage protection (OVP) function may trigger and the output voltage will shut down. Decrease the V_{out} lower than its rated voltage will cause power supply entered into burst mode operation and caused the relay to switch on and off continuously. Furthermore, when increasing the output voltage, reduce the output current so as not to exceed the maximum output power.

4-3. Over Voltage Protection (OVP)

The OVP function will shut down the output. To reset the OVP, disconnect the input voltage from the power supply for a minute and then re-apply. Possible to hiccup if the unit prior to OVP point is already overloaded. Clicking sound of the relay may exhibit during hiccup. The OVP point is fixed and cannot be adjusted externally.

4-4. Over Current Protection (OCP)

Hiccup mode with automatic recovery. If the output current is $>101\%$ of peak load, the unit will hiccup and possible to hear the clicking sound of the relay. Avoid continuous operation in overload or short condition as it may result in damage to the power supply.

4-5. Peak output current

The DRB240 can deliver 120% peak current for 10 seconds aiding the startup of capacitive loads and operation of downstream circuit breakers. The operating conditions for peak output current are as followed:

- Duty cycle of peak current, $D \leq 35\%$
- \leq rated output power and RMS current
- Reduce peak current according to output derating curve for higher ambient temperature.
- Peak output current and its duration are defined as followed:

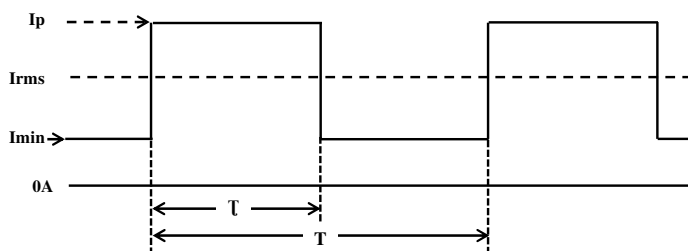

I_p : Peak output current (A)
 I_{rms} : Rms output current (Arms)
 I_{min} : Minimum output current (A)
 T : Peak current pulse width (sec)
 T : Period (sec)

Input voltage range (V_{in}) : 85V - 264V
 Continuous peak output time (T) : Within 10 sec
 Peak output current (I_p) : Within rated peak output current
 Rms output current (I_{rms}) : Within rated rms output current

Duty, $D = T / T \times 100\% \leq 35\%$
 $I_{rms} = [I_p^2 \times D + I_{min}^2 \times (1-D)]^{1/2} \leq \text{Rated rms output current}$

4-6. Output Ripple & Noise

The standard specification for maximum ripple value is measured according to measurement circuit as below. When load lines are longer, ripple becomes larger. In this case, electrolytic capacitor, film capacitor, etc. might be necessary to use across the load terminal. The output ripple cannot be measured accurately if the probe ground lead of oscilloscope is too long.

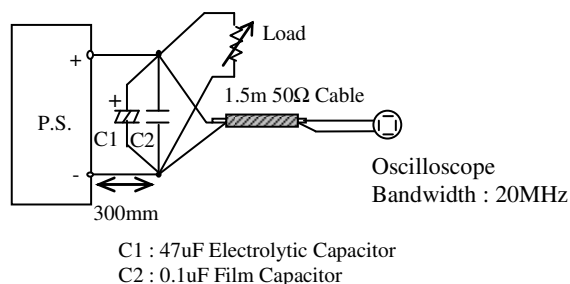

4-7. Series Operation

For series operation, either method (A) or (B) is possible.

Method (A)

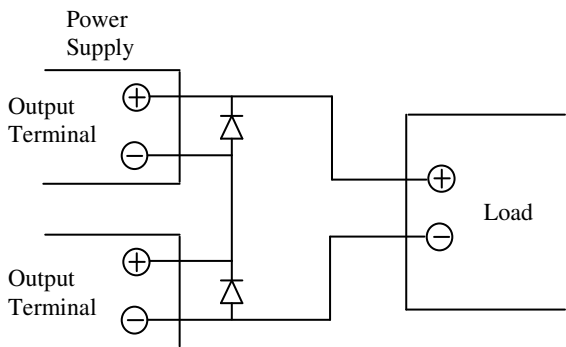

Method (B)

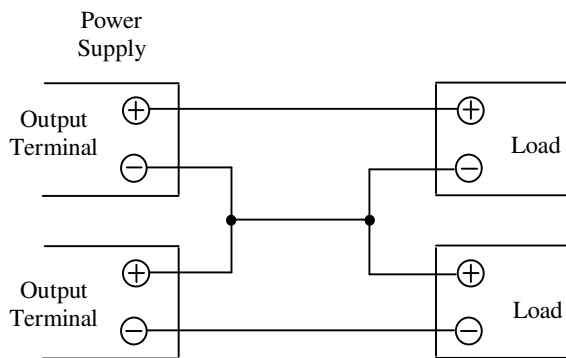

4-9. Withstand Voltage

This series is designed to withstand 4243VDC between input and output, 2500VDC between input and \oplus (Protective Earth) and 707VDC between output and the \oplus (Protective Earth) for 1 minute each. When testing withstand voltage, set current limit of the withstand voltage test equipment to 20mA (Output - \oplus (Protective Earth) : 100mA). The applied voltage must be gradually increased from zero to the testing value and then gradually decreased for shut down. When timer is used, the power supply may be damaged by high impulse voltage at timer switch on and off. Connect input and output as follows.

Input ~ Output (dotted line)

4243VDC 1min. (20mA)

Input ~ \oplus (Protective Earth) (solid line)

2500VDC 1min. (20mA)

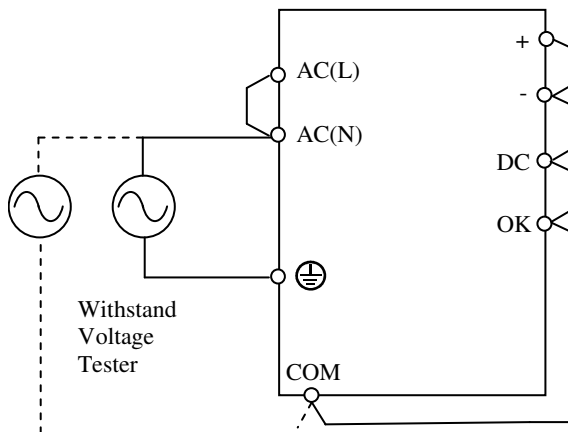

4-8. Isolation Test

Isolation resistance between output and \oplus (Protective Earth) shall be more than 100M Ω at 500VDC. For safety operation, voltage setting of DC isolation tester must be done before the test. Ensure that the unit is fully discharged after the test.

Output ~ \oplus (Protective Earth) : 500VDC 100M Ω or more

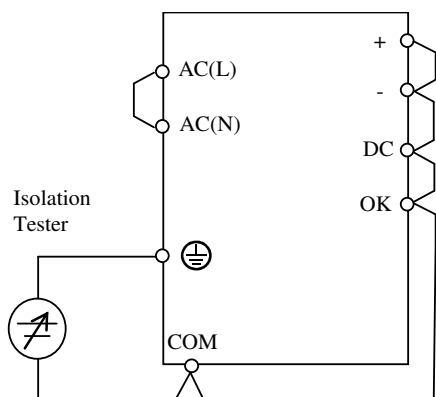

Output ~ \oplus (Protective Earth)

707VDC 1min. (100mA)

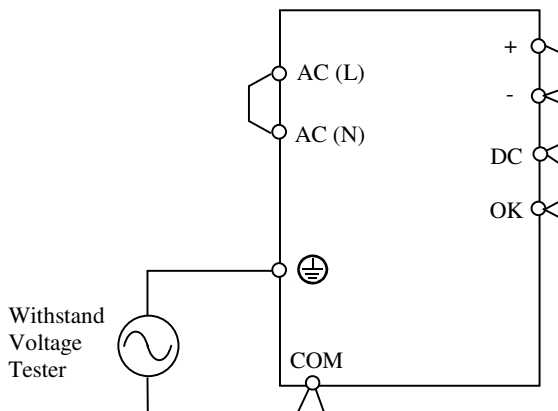

4-10. Output Dynamic Load Response

During output dynamic load test (0%-100% load), the output voltage level might experience a higher voltage dip of -6% (typ).

For example, $V_{IN} = 230VAC$ Dynamic Load = 0% - 100%
 $T_a = 25degC$, the output voltage level dip will be -6% (typ).

5. DC OK

In normal operation the DC OK (optocoupler) is closed when the output voltage is greater than 80% of nominal output voltage. When the output is less than 80% of nominal output voltage the optocoupler is open.

6. Mounting Directions

Recommended standard mounting method is vertical with the output connector uppermost. Do not exceed the load deratings. See section 7. Leave enough space surround the units to ventilate heat efficiently.

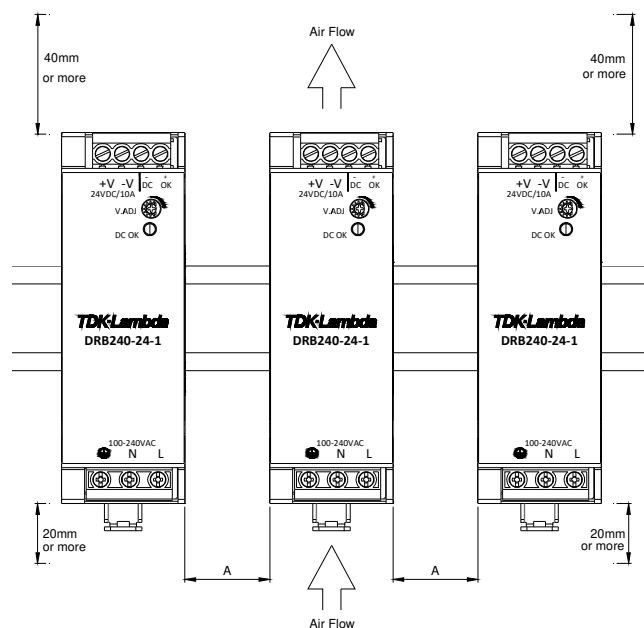

Minimum Installation clearances:

40mm on top, 20mm on the bottom, $A=5mm$ which is recommended on the left and right side when products are permanently loaded with full 240W. In case the adjacent device is a heat source, $A=15mm$ clearance is recommended. The ambient temperature (T_a) is reference 20mm from the bottom of the unit.

6.1. Power supply mounting on DIN RAIL (TS35 or equivalent)

Make sure input and output wire disconnected when mount power supply onto rail

- (1) Tilt the unit slightly rearwards, fit the unit over top hat rail.

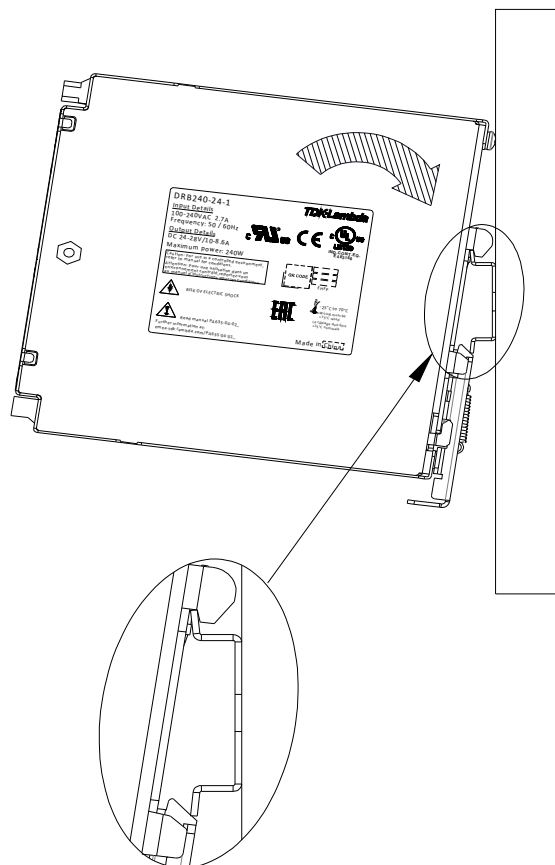

- (2) Slide it downward until it hits the stop.

- (3) Press against the bottom front side for locking.
 Shake the unit slightly to check the locking action.

7. Output Derating – DRB240 series

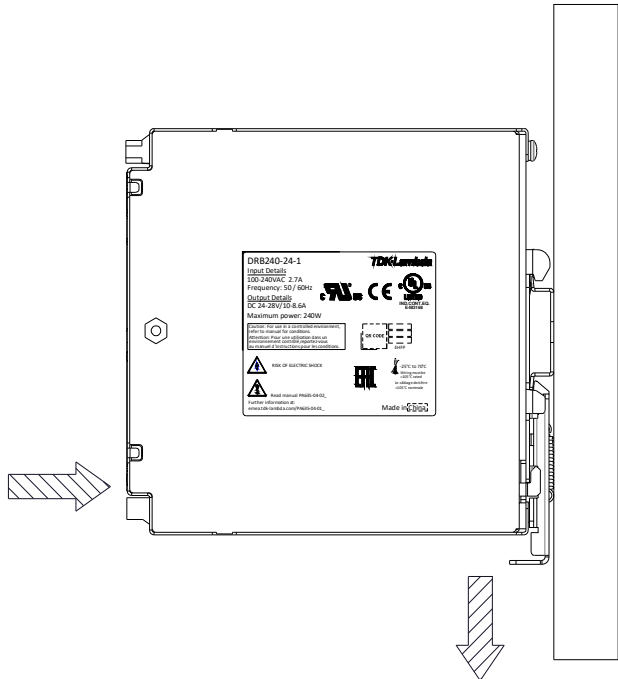

OUTPUT DERATING CURVE

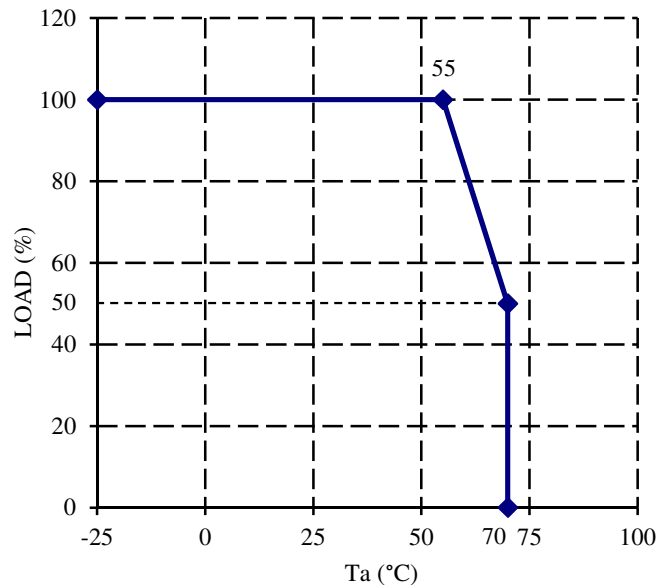

- (4) In order to tighten the unit mounting, the Din rail stopper attached on both sides of the unit is recommended.

6.2. Power supply removal from DIN RAIL

- (1) Switch main power off and disconnect your system from the supply network. Pull the Latch on the rear lower edge of the unit downwards and gently lift lower front edge of the unit (tipping upwards) and remove it.

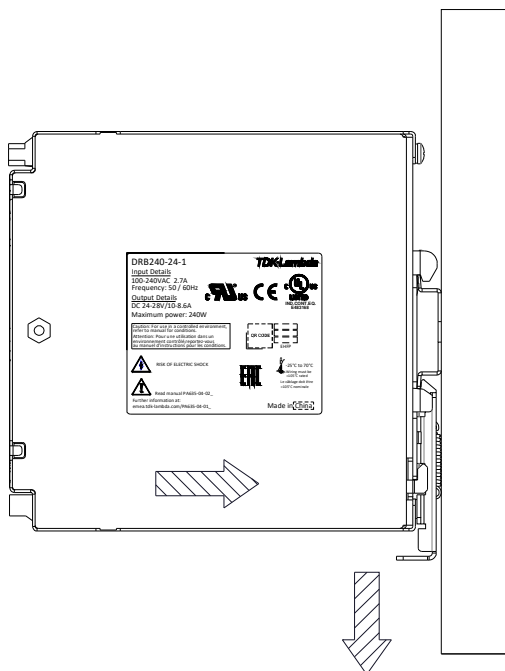

8. Wiring Method

The output load line and input line shall be separated and twisted to improve noise sensitivity. Use all lines as thick and short as possible to make lower impedance. Noise can be eliminated by attaching a capacitor to the load terminals. EMI reduction performance by winding the cable around a toroidal ferrite core several times. Use any appropriate commercially available ferrite core from local vendor. For safety and EMI considerations, connect \oplus (Protective Earth) terminal of input connector to ground terminal of equipment.

8.1 EMC

The DRB240 complies with the provisions of the EMC directive and meets the following standards:
 Emissions: EN55011/EN55032 Class B, EN61204-3 Class A
 Immunity: EN61000-4-2, -3, -4, -5, -6, -8, -11

9. Phase to phase operation

The DRB240 is protected by an internal fuse in the Live line. When connecting the DRB240 between two phases of a three phase system an external fuse or circuit breaker must be used in the Neutral line (N). This is to protect against a fault between the now 'live' Neutral line and Earth. See section 10 for external protection requirements.

Note: The phase-to-phase supply must not exceed the safety approval input voltage of 100-240VAC+10% and 20A Max branch circuit current.

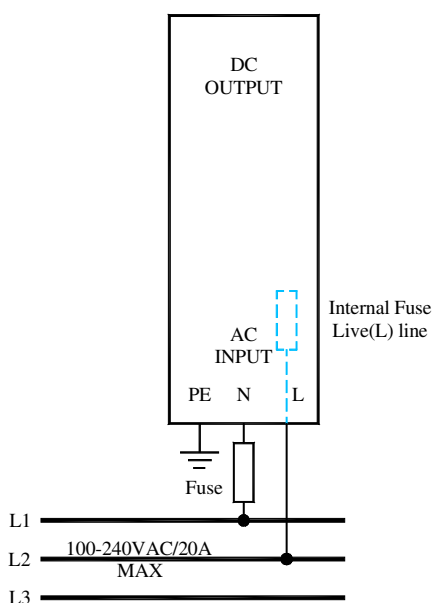

10. External Fuse Rating

If required a 250Vac/6.3A rated fuse should be fitted externally on the input line. Surge current flows when line turns on. Use slow-blow fuse or time-lag type fuse. Do not use fast-blow fuse. Fuse rating is specified by in-rush current value at line turn-on. Do not select the fuse according to input current (RMS.) values under the actual load condition.

11. DRB240 series UL508 Listed Condition

WIRING

Connector	Recommended Wire	Max. Torque
Input (L, N, \oplus)	10~24 AWG	10.3 kgf.cm (9 lbf.in)
Output (+V, -V)	10~24 AWG	10.3 kgf.cm (9 lbf.in)
Output (DC OK)	10~24 AWG	10.3 kgf.cm (9 lbf.in)

- 1) Wire requirement is rated at minimum 105°C and to use copper conductor only.
- 2) For use in a Pollution degree 2 environment only.
- 3) These products are considered for use where maximum surrounding air temperature does not exceed 70°C. When installing these products please refer to section 7 for derating.
- 4) For indoor use only.

Product marking:

TDK-Lambda

TDK-Lambda Singapore Pte. Ltd.

(Sales, Services and R&D)

1008 Toa Payoh North #06-01/08, #07-01/03

Singapore 318996

Telephone: +65 62517211

Facsimile: +65 62509171

WEBSITE: www.sg.lambda.tdk.com

Or WEBSITE: www.emea.lambda.tdk.com/uk

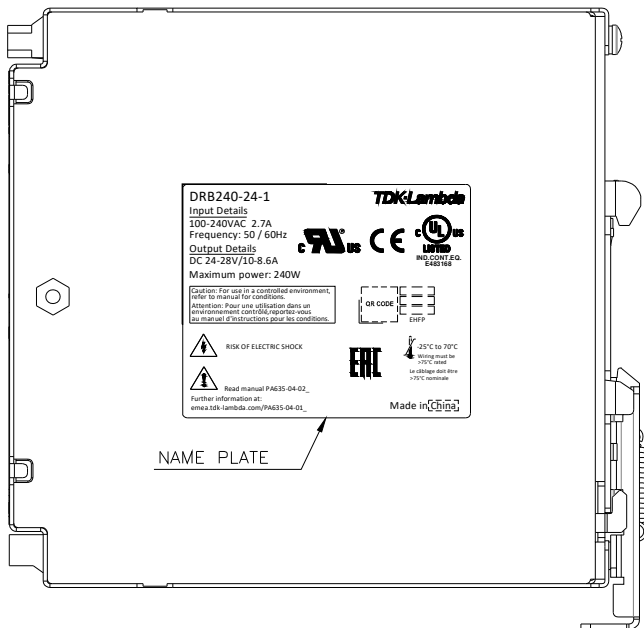

Note : Name plate's contents shown in this instruction manual is for reference only.

12. Before concluding that the unit is at fault...

Before concluding that the unit is at fault, make the following checks.

Check if the rated input voltage is connected.

Check if the wiring of input and output is correct.

Check if the wire material is not too thin.

Check if the output voltage control (V.ADJ) is properly adjusted.

Check if the output current and wattage is not over specification.

Audible noise can be heard during Dynamic-Load operation.

Audible noise can be heard when input voltage waveform is non-sinusoidal wave.

Audible noise can be heard during no or light load condition where the unit entered into burst mode operation.

Clicking sound of the relay may exhibit during no load condition below rated output voltage.

13. Returns

Please contact your local sales office or visit our website to arrange return of any faulty product.



SCATTERGOOD & JOHNSON LTD

ELECTRICAL ENGINEERING & FLUID CONTROL DISTRIBUTORS

Est.1899

At Scattergood & Johnson Ltd, we pride ourselves on being a technical distributor to specialist industries.

Working with a range of quality product suppliers across a number of specialist markets, we are not your average 'box shifter' - we are your technical and supply chain partner.

We fully support every product we sell - for free! Our internal team and external sales engineers can answer any product or application question, no matter the complexity.

Backing up this technical ability is a range of 50,000+ products available from stock for nationwide next day delivery (same day if required!), or you can collect what you need from any of our trade counters around the UK.

Select your specialist interest below to learn more about how we can help.



Online, In Branch and On the Road - Scattergood & Johnson Ltd, there when you need us.

www.scatts.co.uk