

E-T-A® REX12 Electronic Circuit Protector

Description

The compact and flexible all-in-one solution REX consists of several perfectly matched components. It comprises the EM12-T supply module for the plus and minus potential via a single or double channel REX12-T electronic circuit protector which can be mounted side by side in any number and the PM12-T potential extension module for plus and minus multiplication. Connection of the only 12.5 mm wide modules is exclusively with push-in terminals which allow no-tool time-saving wiring.

The circuit protectors are placed on the symmetrical rail one after another in combination with EM12-T and PM12-T and are electrically connected by means of built-in connector arm - no further accessories are required. The circuit protector REX12-T offers selective overcurrent protection by responding to short circuit or overload faster than the switch mode power supply. Capacitive loads of up to 20,000µF can be switched on without problems. The circuit protector is available in all standard fixed and adjustable current ratings from 1 A to 10 A. Besides the UL508listed approval and NEC Class2, the REX12-T also meets the requirements of cable protection to EN60204-1.

US patent number: US 9,899,807 B2



Features

- Combination of supply modules, overcurrent protection and power distribution
- Selective load protection by means of electronic trip curve
- No accessories required for connecting the components
- Width per channel only 12.5 mm (1-channel) or 6.25 mm (2-channel)
- Fixed and adjustable current ratings 1 A - 10 A
- Integral fail-safe element, adjusted to max. current rating
- Switching capacitive loads up to 20,000 µF
- Manual ON/OFF/reset momentary switch
- Clear status indication by means of LED and signal contact Si
- Connection via push-in terminals including orange press release buttons

Benefits

- Saves cost – no further accessories required
- Saves 50 % time through innovative and flexible mounting and connection technology
- Saves space – with a width of only 12.5 mm per channel
- Provides flexibility through ease of mounting, disassembly and modular design
- Reduces storage costs because only one product is required for all current ratings

Preferred types – for more details on all configurations please see page 4

Preferred types are E-T-A products most frequently used by E-T-A customers. We manufacture E-T-A preferred types in particularly high

volumes. Our preferred types are supplied at shorter lead times than non-standard versions.

Preferred types

Preferred types	Short description	Preferred ratings (A)						
REX12-TA1	1-channel	2	4	6	10	2/2	4/4	6/6
REX12-TA1-107-DC24V-		x	x	x	x			
REX12-TA2	2-channel	2	4	6	10	2/2	4/4	6/6
REX12-TA2-107-DC24V-						x	x	x
REX12D-TE2	2-channel, adjustable	1 A...10 A						
REX12D-TE2-100-DC24V-		x						

Approvals



Data sheet

The current data sheet is available on our website: www.e-t-a.de/d359

Compliances



REX12 Electronic Circuit Protector
Technical data ($T_{amb} = +23\text{ }^{\circ}\text{C}$, $U_B = \text{DC } 24\text{ V}$)
REX12-Txx-xxx circuit protectors

REX12-TA1-107-DC24V-xA	1-channel
REX12-TB1-107-DC24V-xA	1-channel
REX12-TA2-107-DC24V-xA/xA	2-channel
REX12D-TE2-100-DC24V-xA-xA	2-channel

The REX12-TAx is operated in the standard mode with EM12-T. The REX12D-TE2 can be operated both with EM12D-T or EM12-T. The operating mode EM12D-T (COM mode) or EM12-T (standard) is recognised automatically. The following data exclusively refer to the standard mode:

Operating voltage U_B	DC 24 V (18...30 V)
Closed-circuit current I_0	
REX12-Tx1 1-channel in ON condition: Typically 5 mA	
REX12-TA2 2-channel in ON condition: Typically 8 mA	
REX12D-TE2 1 A-4 A 2-channel in ON condition: Typically 9 mA	
REX12D-TE2 1 A-10 A 2-channel in ON condition: Typically 12 mA	
Reverse polarity protection	Yes
Power failure buffering time	up to 10 ms
Rated current I_N	ratings:
REX12-Tx1	1 A, 2 A, 3 A, 4 A, 6 A, 8 A, 10 A
REX12-TA2	1 A/1 A, 2 A/2 A, 3 A/3 A, 4 A/4 A, 6 A/6 A
REX12D-TE2	1 A-4 A, 1 A-10 A condition upon delivery max. current rating
Visual status indication by means of LED	green: Load circuit connected green/orange blinking: load current warning limit reached 90 % orange: overload or short circuit until disconnection red: - after disconnection due to overload or short circuit - after undervoltage release of operating voltage in ON condition with autoreset OFF: Device switched off by means of ON/OFF momentary switch or no operating voltage

Load circuit

Load output	power MOSFET switching output (plus switching)
Load current warning limit (I_{WLimit}) hysteresis	typically $0.9 \times I_N$ typically 5 %
Overload current disconnection (I_{UL})	typically $I_{OL} : I_N \times 1.05$ $t_{OL} : 3s$ typically $I_{OL} : I_N \times 1.35$ $t_{OL} : 0.5s$ typically $I_{OL} : I_N \times 2.00$ $t_{OL} : 0.1s$ typically $I_{OL} : I_N \times 2.50$ $t_{OL} : 0.012 s$
with trip times (t_{UL})	typically at short circuit (I_{SC}) $t_{SC} : 0.002 s^2$ see time/current characteristic
short circuit trip time (t_{SC})	see time/current characteristic
Influence of ambient temperature on overload disconnection and load current warning limit	see temperature factor table
Voltage drop in load circuit at I_N and at I_N 70 % for REX12-Txx between LINE+ and LOAD+	
I_N : 1 A (CL2)	typically 180 mV I_N : 70 % typically 125 mV
I_N : 2 A (CL2)	typically 110 mV I_N : 70 % typically 80 mV
I_N : 3 A	typically 120 mV I_N : 70 % typically 85 mV
I_N : 3 A-CL2	typically 130 mV I_N : 70 % typically 90 mV
I_N : 4 A	typically 115 mV I_N : 70 % typically 80 mV
I_N : 4 A-CL2	typically 180 mV I_N : 70 % typically 120 mV
I_N : 6 A	typically 170 mV I_N : 70 % typically 110 mV
I_N : 8 A	typically 160 mV I_N : 70 % typically 105 mV
I_N : 10 A	typically 180 mV I_N : 70 % typically 120 mV

Technical data ($T_{amb} = +23\text{ }^{\circ}\text{C}$, $U_B = \text{DC } 24\text{ V}$)
REX12D-TE2-100-DC24V-1A-4A-CL2

I_N : 1 A-CL2	typically 50 mV	I_N : 70 %	typically 42 mV
I_N : 2 A-CL2	typically 90 mV	I_N : 70 %	typically 70 mV
I_N : 3 A-CL2	typically 135 mV	I_N : 70 %	typically 95 mV
I_N : 4 A-CL2	typically 180 mV	I_N : 70 %	typically 120 mV

REX12D-TE2-100-DC24V-1A-10A

I_N : 1 A	typically 30 mV	I_N : 70 %	typically 28 mV
I_N : 2 A	typically 39 mV	I_N : 70 %	typically 34 mV
I_N : 3 A	typically 48 mV	I_N : 70 %	typically 40 mV
I_N : 4 A	typically 57 mV	I_N : 70 %	typically 46 mV
I_N : 5 A	typically 66 mV	I_N : 70 %	typically 52 mV
I_N : 6 A	typically 74 mV	I_N : 70 %	typically 59 mV
I_N : 7 A	typically 83 mV	I_N : 70 %	typically 65 mV
I_N : 8 A	typically 92 mV	I_N : 70 %	typically 71 mV
I_N : 9 A	typically 101 mV	I_N : 70 %	typically 77 mV
I_N : 10 A	typically 110 mV	I_N : 70 %	typically 83 mV

2) depending on power source

Fail-safe element integral blade fuse adjusted to related current rating I_N	I_N : 1 A (CL2) I_N : 2 A (CL2) I_N : 3 A I_N : 3A-CL2 I_N : 4 A I_N : 4 A-CL2 I_N : 6 A I_N : 8 A I_N : 10 A I_N : 1 A/1 A (CL2) I_N : 2 A/2 A (CL2) I_N : 3 A/3 A I_N : 3 A/3 A-CL2 I_N : 4 A/4 A I_N : 4 A/4 A-CL2 I_N : 6 A/6 A I_N : 1 A-4 A-CL2 I_N : 1 A-10 A	fail-safe I_N : 1 A fail-safe I_N : 2 A fail-safe I_N : 3.15 A fail-safe I_N : 4 A fail-safe I_N : 4 A fail-safe I_N : 4 A fail-safe I_N : 6.3 A fail-safe I_N : 8 A fail-safe I_N : 10 A fail-safe I_N : 1 A/1 A fail-safe I_N : 2 A/2 A fail-safe I_N : 3.15A/3.15A fail-safe I_N : 4 A/4 A fail-safe I_N : 4 A/4 A fail-safe I_N : 4 A/4 A fail-safe I_N : 6.3 A/6.3 A fail-safe I_N : 4 A failsafe I_N : 16 A
operating voltage monitoring re. undervoltage	OFF at typically $U_B < 16.0\text{ V}$ ON at typically $U_B > 19.0\text{ V}$ hysteresis typically 2 V with automatic OFF and ON switching	

ON delay - with power ON	channel 1: typically 100 ms (REX12-TAx) channel 2: typically 200 ms (REX12-TAx) channel 1: typically 1,500 ms (REX12D-TE2) channel 2: typically 1,600 ms (REX12D-TE2)
- when switching on with ON/OFF switch or - after undervoltage	channel 1: typically 5 ms channel 2: typically 100 ms channel 1: typically 5 ms channel 2: typically 5 ms
disconnection of	- manually on the device with the ON/OFF momentary switch - after an overload / short circuit disconnection with storage (no automatic reset) - temporarily at undervoltage - at no operating voltage

Switch-on of load circuit

- momentary switch ON/OFF	device can only be switched on when operating voltage is applied
- applying operating voltage	The device starts up with the condition last stored.

REX12 Electronic Circuit Protector

Technical data ($T_{amb} = +23\text{ °C}$, $U_B = \text{DC } 24\text{ V}$)

Enquire adjusted current rating with REX12D-TE2

Enquiry of currently adjusted current rating, independent of the operating mode (COM or standard), possible for each channel directly on the REX12D-TE2
Enquiry mode is started by pushing the button between ≥ 2 seconds and < 5 seconds After releasing the button, the LED is RED for 333 ms to indicate start of enquiry. Afterwards, the LED flashes ORANGE in a puls/break ratio of 1/2 with a frequency of 1 Hz to indicate the adjusted current value. When the adjusted current rating is reached, signalling re-starts after the RED LED re-lights for 333 ms. The enquiry mode is left after the adjusted current rating was signalled 5 times or by pressing the button. Visual indication will now show again the current operating condition.
The enquiry mode is possible in all operating conditions (ON, OFF, UNDERVOLTAGE and TRIPPED).

Adjustment of current rating with REX12D-TE2

The adjustment mode directly on the REX12D-TE2 can only be activated in the standard mode
The adjustment mode is started per channel by pushing the button for ≥ 5 seconds. After releasing the button, the LED is RED for 333 ms to indicate start of adjustment. The LED is blinking GREEN with a pulse/break ratio of 1/4 at a frequency of 0.6 Hz for visual indication. GREEN After reaching the max. adjustment value, signalling re-starts. Overrun of the max. adjustment value after 1 Ampere is indicated by the RED LED (333 ms). The current rating to be adjusted is adopted by pushing the button during the blinking period of 1 A up to the max. adjustment value. If for instance the button is pushed after the 7th illumination of the GREEN LED, 7A is adopted as current rating and visual indication again shows the current operating condition. If the button is not pressed, the adjustment mode is left after 5 times signalling the current rating range without a new current rating being adopted and the visual indication returns to current status indication.
The adjustment mode is possible in all operating conditions (ON, OFF, UNDERVOLTAGE and TRIPPED).

Go to video **Mounting and operation:**



Reset function

a blocked load output (blocked by overload / short circuit) can externally be reset by the ON/OFF momentary switch

Leakage current in load circuit in OFF condition

typically $< 1\text{ mA}$

Technical data ($T_{amb} = +23\text{ °C}$, $U_B = \text{DC } 24\text{ V}$)

Capacitive loads	up to 20,000 μF : depending on: cable attenuation, power supply used, load current and current rating
Free-wheeling diode	external free-wheeling circuit at inductive load (rating according to load)
Parallel connection of several load outputs	not allowed
Status output SM	status indicator in REX system
Electrical data	minus switching signal output Group signalling is implemented in connection with EM12-T supply module
Terminals LOAD+	
Push-in terminal PT 2.5	0.14 mm ² ...2.5 mm ² flexible AWG24 – AWG14 rigid
stripping length	8 mm...10 mm
Dimensions (w x h x d)	12.5 x 80 x 98.5 mm
Mass	
REX12-TA1-xxx 1-channel	approx. 57 g
REX12-TB1-xxx 2-channel	approx. 60 g
REX12-TA2-xxx 2-channel	approx. 58 g
REX12D-TE2-xxx 2-channel	approx. 62 g
General data REX / EM / PM	
Housing material	moulded
Mounting	symmetrical rail to EN 60715-35x7.5
Ambient temperature T_U	-25 °C...+60 °C (without condensation, cf. EN 60204-1)
Storage temperature	-40 °C ... +70 °C
Mounting temperature	+5°...+60 °C
Humidity	96 hrs / 95% RH/40 °C to IEC 60068-2-78-Cab climate class 3K3 to EN 60721
Altitude	2,000 m above sea level 3,000m above sea level up to +55 °C 4,000m above sea level up to +50 °C
Operation pressure	4 bar above atmospheric pressure
Corrosion only PM and EM accessories	96hrs. in 5 % salt mist to IEC 60068-2-11 test Ka
Vibration	5 g test to IEC 60068-2-6, test Fc
Degree of protection (IEC 60529, DIN VDE 0470) operating area REX12:	IP30
terminal area EM, PM:	IP20
EMC requirements (EMC directive, CE logo)	noise emission EN 61000-6-3 susceptibility: EN 61000-6-2
Insulation co-ordination (IEC 60934)	0.5 kV / pollution degree 2
Dielectric strength	max. DC 30 V (load circuit)
Insulation resistance (OFF condition)	n/a, only electronic disconnection
Conformity	CE marking

E-T-A® REX12 Electronic Circuit Protector

Approvals and standards

Approval authority	Standard	UL file no.	Voltage ratings	Current rating range
UL	UL 2367, UL 1310 NEC Class2	E306740	DC 24 V	1...10 A 1 A, 2 A, 3 A, 4 A, 1 A...4 A
UL	CSA C22.2 No. 213 (Class I, Division 2, Groups A, B, C, D)	E320024	DC 24 V	1...10 A
UL	UL 508 listed, CSA C22.2 No. 14	E492388	DC 24 V	1 A...10 A

PM and EM – accessories approvals see technical data of accessories

Preferred types - a short explanation

Preferred types are E-T-A products most frequently used by E-T-A customers. We manufacture E-T-A preferred types in particularly high

volumes. Our preferred types are supplied at shorter lead times than non-standard versions.

Preferred types

Preferred types	Short description	Preferred ratings (A)						
		2	4	6	10	2/2	4/4	6/6
REX12-TA1	1-channel							
REX12-TA1-107-DC24V-		x	x	x	x			
REX12-TA2	2-channel							
REX12-TA2-107-DC24V-						x	x	x
REX12D-TE2	2-channel, adjustable	1 A...10 A						
REX12D-TE2-100-DC24V-		x						

Ordering number code – REX12-T

Type	REX12 Electronic circuit protector with PT connection technology
Mounting method	T rail mounting
Design	A 1 load output terminal per channel, fixed current ratings xA or xA/xA
	B 2 load output terminals per channel, fixed current ratings xA (only 1 channel)
Number of channels	1 1 channel (only 1-channel)
	2 2 channels
Version	1 without physical isolation
Signal input	0 without signal input
Signal output	7 status output
Operating voltage	DC 24 V voltage rating DC 24 V
Rated current	1 A (only 1 channel, Class2) 2 A (only 1 channel, Class2) 3 A (only 1 channel) 4 A (only 1 channel) 6 A (only 1 channel) 8 A (only 1 channel) 10 A (only 1 channel) 1 A / 1 A (only 2 channels, Class2) 2 A / 2 A (only 2 channels, Class2) 3 A/3 A (only 2 channels) 4 A/4 A (only 2 channels) 6 A/6 A (only 2 channels)
Approval	CL2 Class2 (only 3A and 4A versions)
Example 1	REX12 - T A 1 - 1 0 7 -DC24V - 10 A example (1-channel)
Example 2	REX12 - T A 2 - 1 0 7 -DC24V - 4A/4A - CL2 example (2-channel)

Ordering number code – REX12D-TE2

Type	REX12D intelligent electronic circuit protector with PT connection technology
Mounting method	T rail mounting
Design	E 1 load output terminal per channel, variable current ratings xA/xA, adjustable standard and COM mode
Number of channels	2 2 channels
Version	1 without physical isolation
Signal input	0 without signal input
Signal output	0 without signal output
Operating voltage	DC 24 V voltage rating DC 24 V
Rated current	1 A – 10 A (only 2 channels) 1 A – 4 A (only 2 channels)
Approvals	CL2 Class2 (only for 1 A - 4 A version)
Example	REX12D-T E 2 - 1 0 0 - DC24V - 1 A-10 A CL2 ordering example

Custom designed versions

Looking for a version you cannot find in our ordering number code? Please get in touch. We will be pleased to find a solution for you.

4

ET-A[®] REX12 Electronic Circuit Protector

Overview of ordering number codes

Supply module	EM12-T00-000-DC24V-40A EM12-T01-001-DC24V-40A
Circuit protectors: 1-channel	REX12-TA1-107-DC24V-1A (Class2) REX12-TA1-107-DC24V-2A (Class2) REX12-TA1-107-DC24V-3A REX12-TA1-107-DC24V-3A-CL2 (Class2) REX12-TA1-107-DC24V-4A REX12-TA1-107-DC24V-4A-CL2 (Class2) REX12-TA1-107-DC24V-6A REX12-TA1-107-DC24V-8A REX12-TA1-107-DC24V-10A
Circuit protectors: 1-channel 2 load output terminals	REX12-TB1-107-DC24V-1A (Class2) REX12-TB1-107-DC24V-2A (Class2) REX12-TB1-107-DC24V-3A REX12-TB1-107-DC24V-3A-CL2 (Class2) REX12-TB1-107-DC24V-4A REX12-TB1-107-DC24V-4A-CL2 (Class2) REX12-TB1-107-DC24V-6A REX12-TB1-107-DC24V-8A REX12-TB1-107-DC24V-10A
Circuit protectors: 2-channel	REX12-TA2-107-DC24V-1A/1A (Class2) REX12-TA2-107-DC24V-2A/2A (Class2) REX12-TA2-107-DC24V-3A/3A REX12-TA2-107-DC24V-3A/3A-CL2 (Class2) REX12-TA2-107-DC24V-4A/4A REX12-TA2-107-DC24V-4A/4A-CL2 (Class2) REX12-TA2-107-DC24V-6A/6A
Circuit protectors 2-channel, adjustable	REX12D-TE2-100-DC24V-1A-4A-CL2 (Class 2) REX12D-TE2-100-DC24V-1A-10A
Accessories	
Supply modules	EM12-T00-100-LINE-40A EM12-T00-200-LINE-40A EM12-T00-000-GND-40A EM12-T00-300-GND-40A
Potential modules	PM12-T01-00-LOAD-20A PM12-T02-00-LOAD-20A PM12-T03-00-GND-20A

REX12-Quat-Pack-1A-10A electronic circuit protector

REX12-Quat-Pack-1A-10A

4-channel pack, selective load protection, voltage rating DC24V variable current ratings 1A-10A in 1A steps, rail mounting, installation width 37.5 mm, push-in connection technology, signalling with auxiliary contact N/O

current ratings 4 x 1A-10A adjustable

A pack consists of

- 1 supply module, EM12-T01-001-DC24V-40A
- 2 circuit protectors, 2-channel, adjustable 1-10A, REX12D-TE2-100-DC24V-1A-10A

part number: **X22378501**

REX12-Quat-Pack-1A-10A

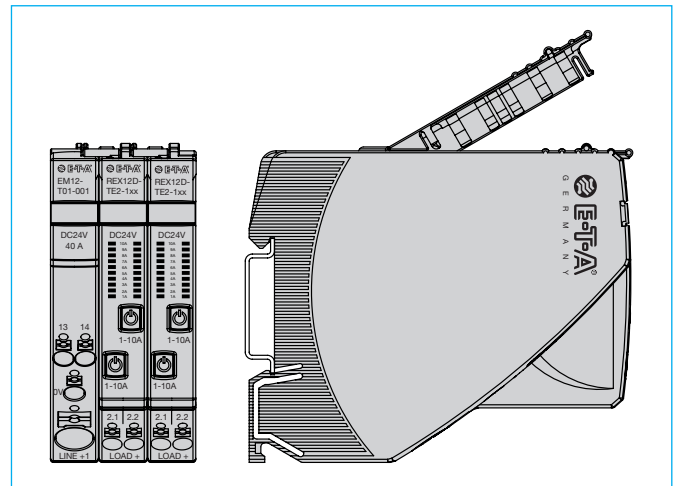

ET-A[®] REX12 Electronic Circuit Protector

Dimensions with connection diagram: REX12-TA1-xxx / REX12-TB1-xxx / REX12-TA2-xxx / REX12D-TE2-xxx

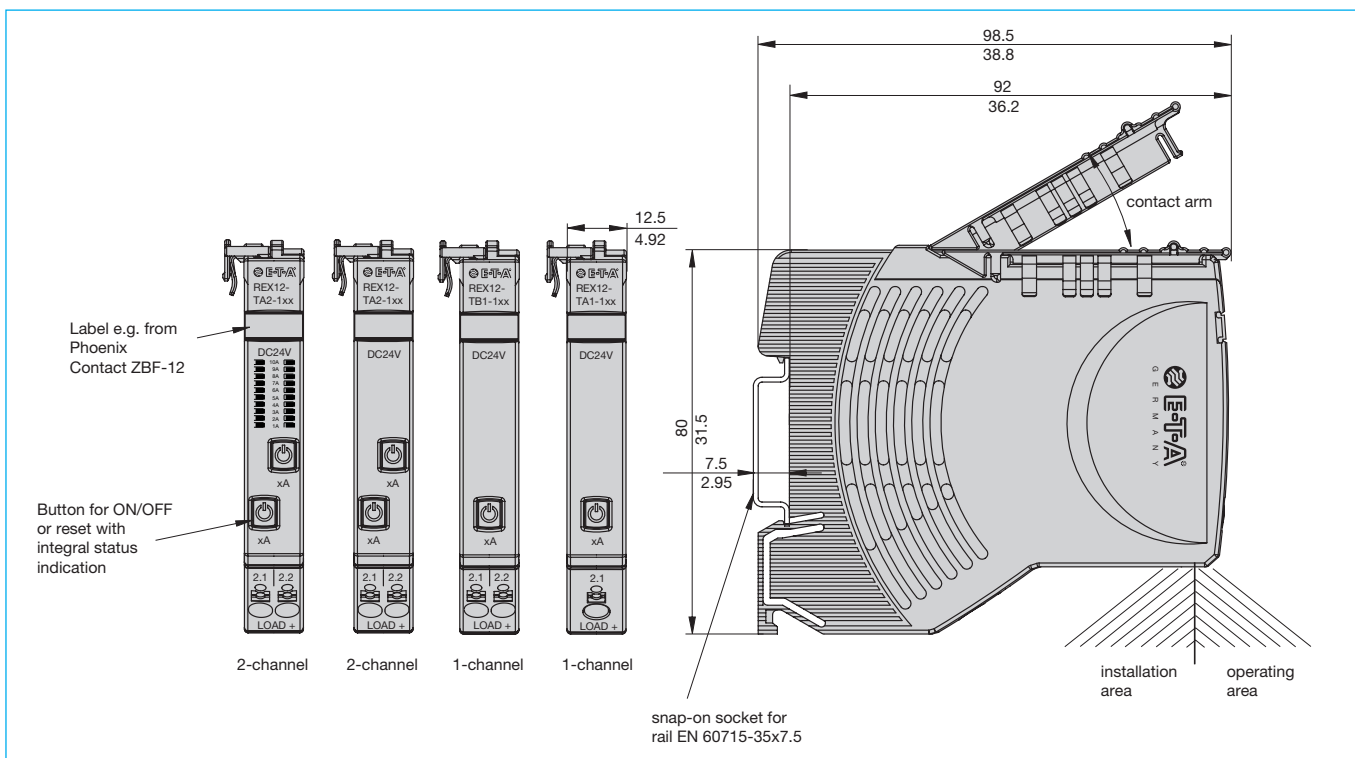

Typical time/current characteristic ($T_{amb} = +23\text{ }^{\circ}\text{C}$, $UB = DC - 24\text{ V}$)

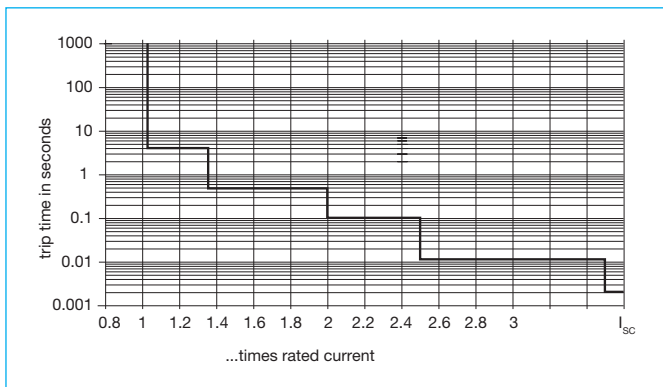

Basic trip curve and schematic diagram REX12

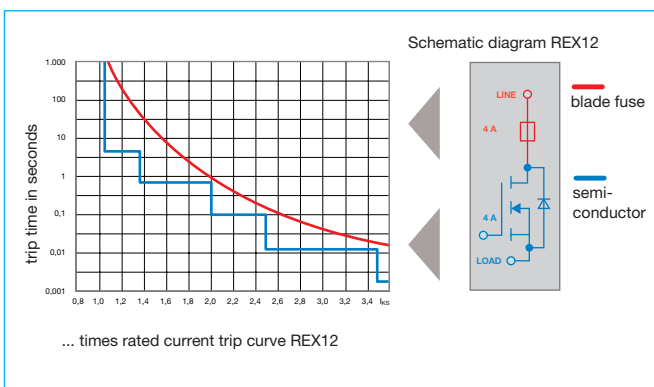

Temperature factor / continuous duty

The time/current characteristic depends on the ambient temperature. In order to determine the max. load current, please multiply the current rating with the temperature factor and consider the factor for side-by-side mounting.

Temperature factor table:

ambient temperature [$^{\circ}\text{C}$]	0	10	23	40	50	60
temperature factor	1	1	1	0.95	0.90	0.85

Note:

When mounted side-by-side, the devices can carry max. 80 % of their rated load or a different rating has to be selected (see Technical Information on www.e-t-a.de/ti_d)

With high temperatures, the load current warning threshold "warn limit typically $0.9 \times I_N$ " will be reduced in accordance with the temperature factor.

Selection of current rating of the circuit protector \leq rating of power supply.

Mounting position REX... preferred mounting position horizontal

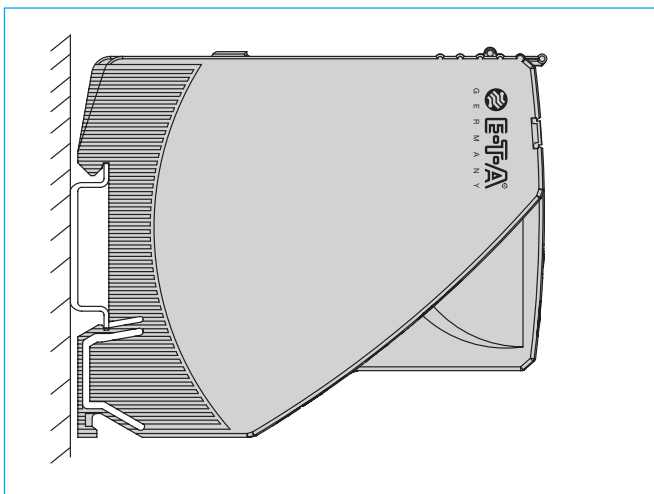

REX12 Electronic Circuit Protector

Description - EM12-T supply module

The EM12-T supply module receives the DC 24 V supply voltage, e.g. from a switch mode power supply, and distributes it to the mounted circuit protectors via the integral connector arm of the REX12-T.

The potential-free auxiliary contact in the EM12-T indicates any detected failures through the circuit protector, e.g. to the superordinate control unit (CPU).

Technical data ($T_{amb} = +23\text{ }^{\circ}\text{C}$, $U_B = \text{DC } 24\text{ V}$)

Operating voltage U_B	DC 24 V (18...30 V)
Operating current I_B	max. 40 A
Reverse polarity protection	Yes
Signalling	only EM12-T01-001-DC24V-40A
Quiescent current I_0	typically 10 mA
potential-free auxiliary change-over contact	max. DC 30 V / 0.5 A min. 10 V / 1 mA
Group signalling Si contact: Si (13) / Si (14)	auxiliary contact, make contact
normal condition:	Auxiliary contact closed based on all protection modules - when ON, load output connected - when OFF, load output disconnected
Fault condition:	Auxiliary contact open based on one or more protection modules - after overload or short circuit trip - after undervoltage release of operating voltage in ON condition with autoreset - at no operating voltage U_B in supply module
Insulation co-ordination	0.5 kV / pollution degree 2
Power failure buffering time	Si up to 10 ms
Screw terminals	LINE+
Push-in terminal PT 10	0.5 mm ² ...10 mm ² flexible AWG24 – AWG8 rigid
stripping length	18 mm
Screw terminals	0 V / Si 13 / Si 14
Push-in terminal PT 2.5	0.14 mm ² ... 2.5 mm ² flexible AWG24 – AWG14 rigid
stripping length	8 mm...10 mm
Dimensions (w x h x d)	12.5 x 80 x 98 mm
Mass	approx. 52 g
Circuit protectors can be mounted side-by-side REX12-Tx1-x or REX12-TA2-x or REX12D-TE2 2-channel max. 16 pcs	

Ordering number code - EM12

Type	EM12	supply module for REX12, with PT connection technology
Mounting method	T	rail mounting
Version: Communication, interface	00	without signal
	01	analog signal
Additional functionality	0	without
Signal input	0	without signal input
Signal output	0	without auxiliary contact
	1	signal make contact
Operating voltage	DC 24 V	voltage rating DC 24 V
Rated current	40 A	Rated current 40 A
EM12 - T 01 - 0 0 1 - DC 24 V - 40 A ordering example		

Dimensions EM12-T01-xxx supply module

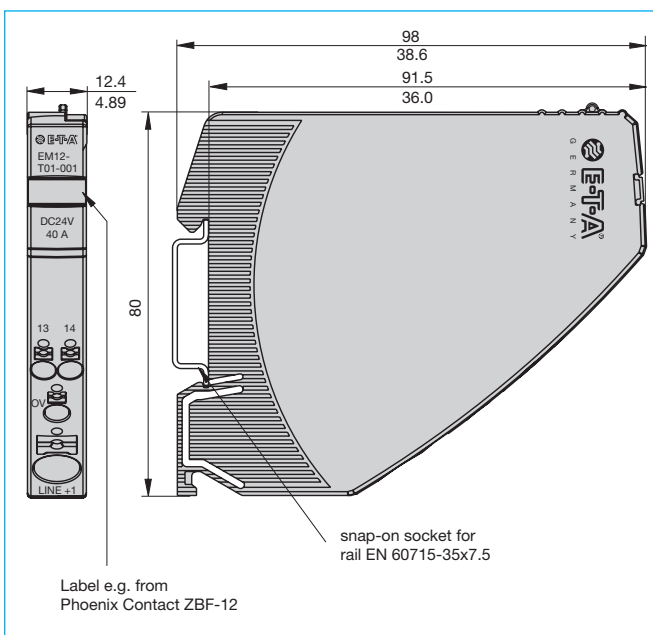

Schematic diagram EM12-Txx-xxx with REX12-xx

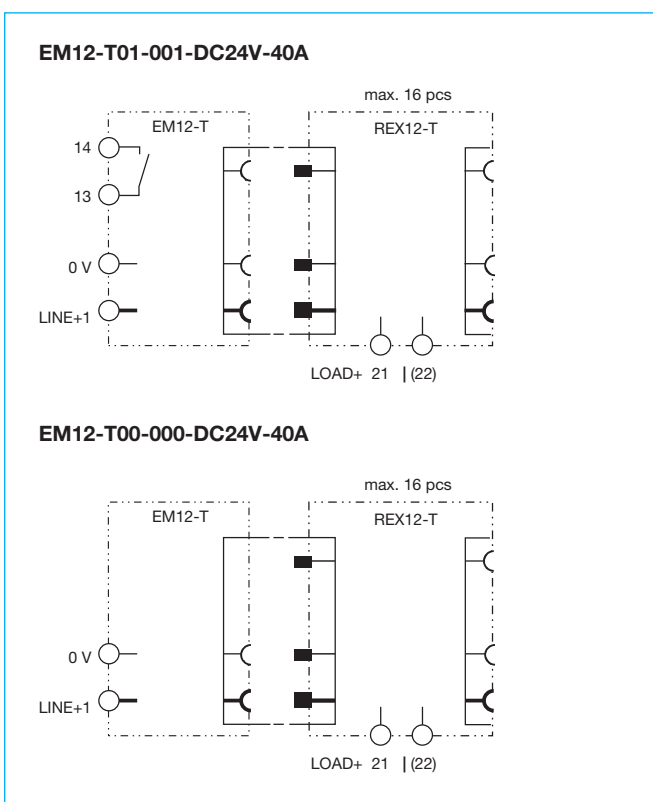

E-T-A® REX12 Electronic Circuit Protector

Application example: REX... mounting on or removing from symmetrical rail

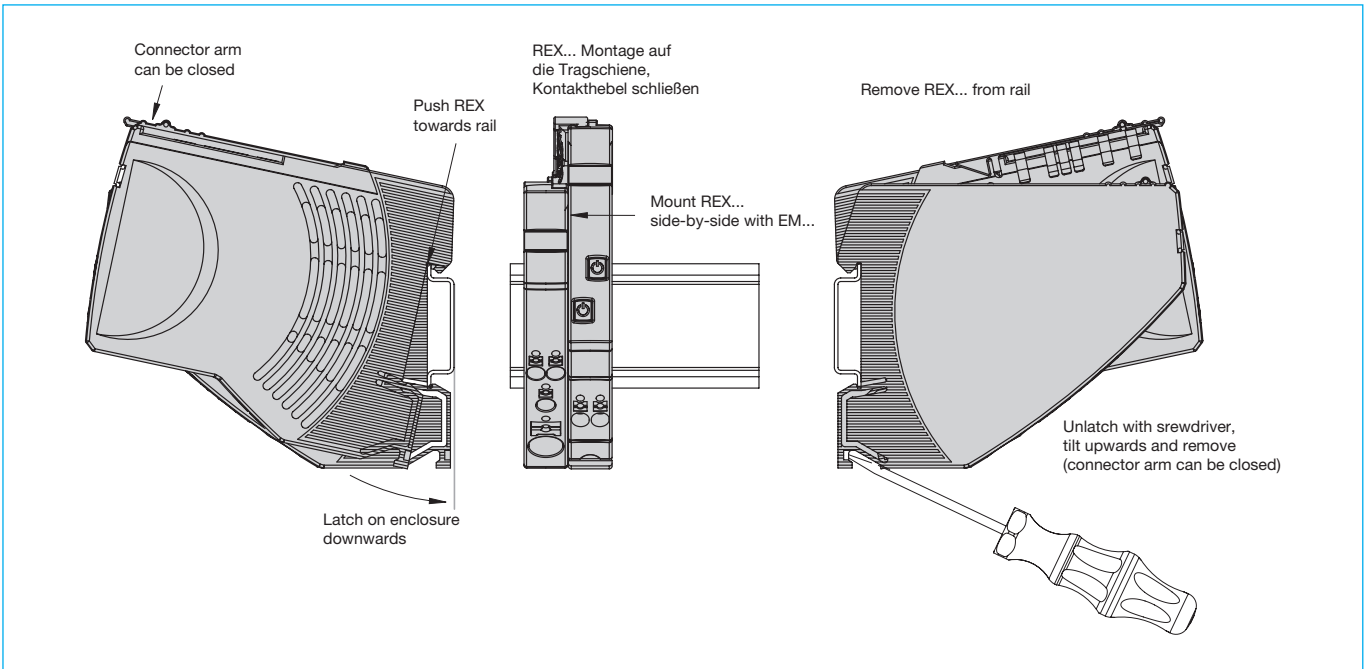

Application example: REX... Replacement or disassembly

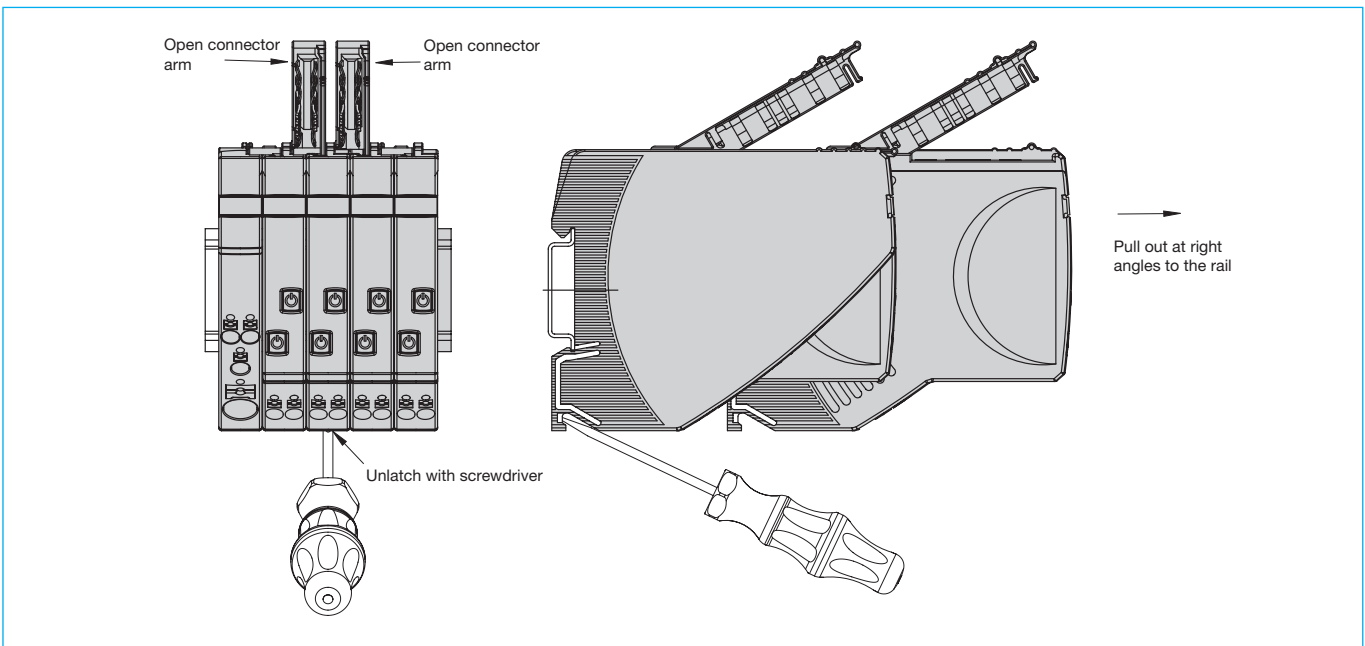

Instructions for installation

Mounting or actuation of the REX connector arm must only be effected at dead-voltage. For start-up the REX connector arm must be closed.

4

E-T-A® REX12 Electronic Circuit Protector

Application example: EM12-T with REX12-TA1... and REX12-TA2...

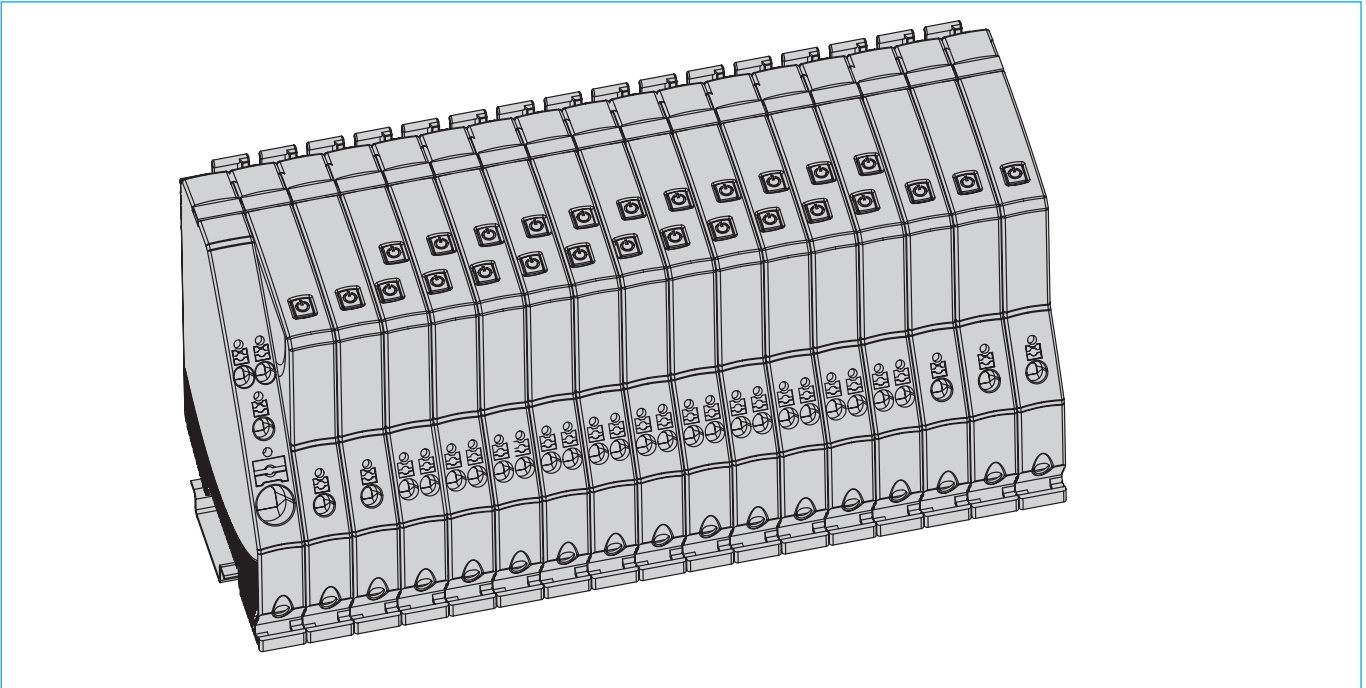

Application example: REX... Locked connector arms

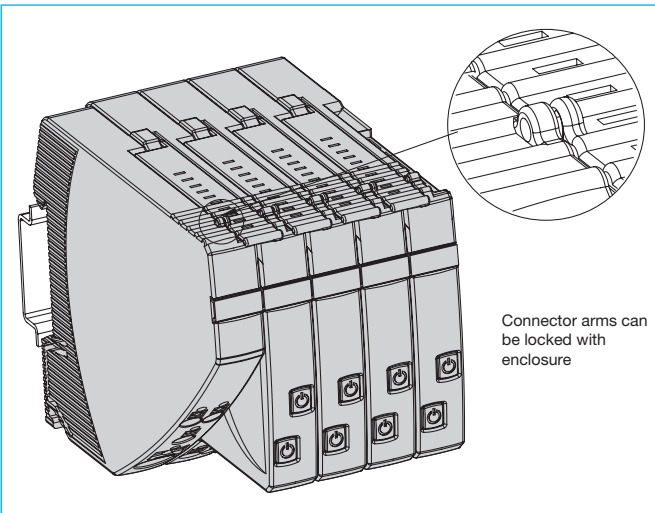

Application example: REX12(D)-T... distance between cable duct and connector arm

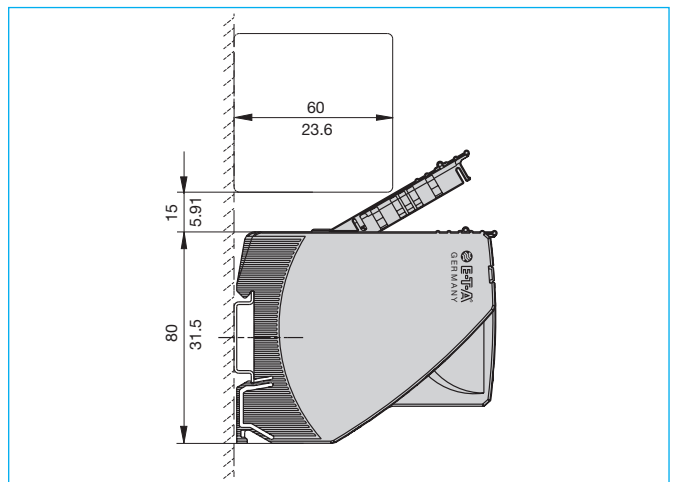

All information and data given on our products are accurate and reliable to the best of our knowledge, but E-T-A does not accept any responsibility for the use in applications which are not in accordance with the present specification. E-T-A reserves the right to change specifications at any time in the interest of improved design, performance and cost effectiveness. Dimensions are subject to change without notice. Please enquire for the latest dimensional drawing with tolerances if required. All dimensions, data, pictures and descriptions are for information only and are not binding. Amendments, errors and omissions excepted. Ordering codes of the products may differ from their marking.

ET-A[®] REX12 Electronic Circuit Protector

Accessories

EM12-T00-000-GND-40A supply module left - 0V - GND

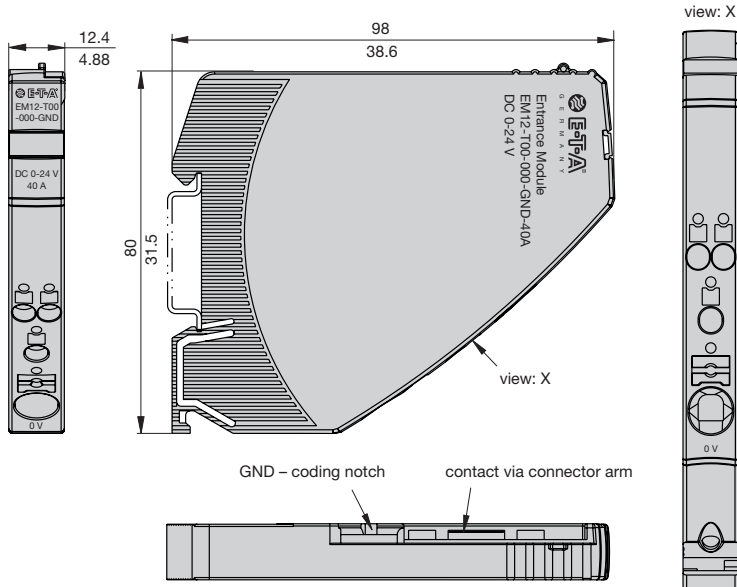

Technical data

Please observe general data of REX / EM / PM	
Operating voltage U_B	0 V – DC 24 V (0...30 V)
Operating current I_B	max. load 40 A
line terminal	0 V – GND
Push-in terminal PT 10	0.5 mm ² ...10 mm ² flexible AWG24 – AWG8 rigid
stripping length	18 mm
Dimensions (w x h x d)	12.5 x 80 x 98 mm
Mass	approx. 40 g
Approvals	UL 1059, File # E335289

Schematic diagram

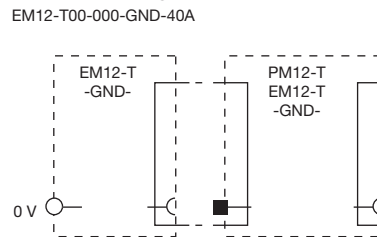

PM12-T03-00-GND-20A potential module - GND (10-way)

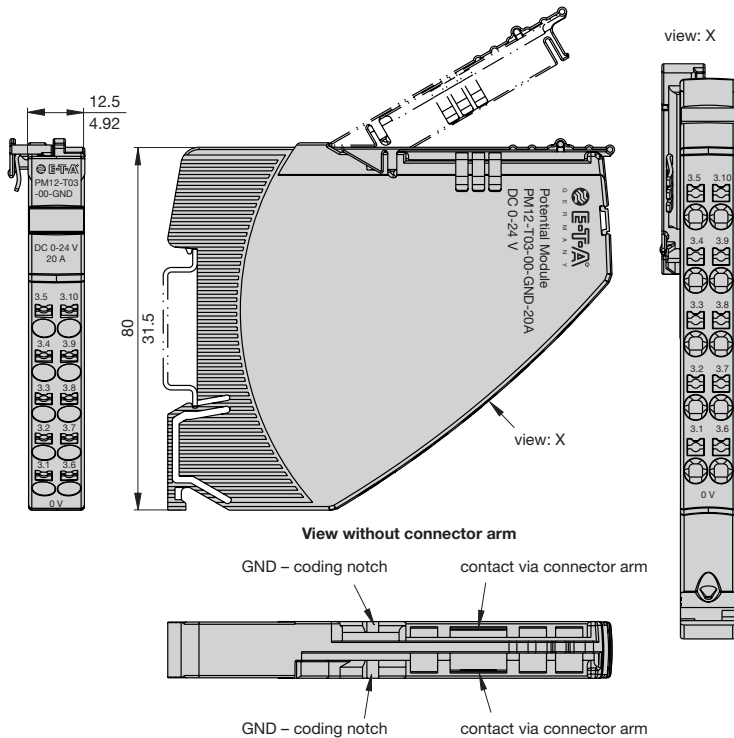

Technical data

Please observe general data of REX / EM / PM	
Operating voltage U_B	0 V – DC 24 V (0 ... 30 V)
Operating current I_B	max. load 20 A
line terminal	0 V – GND
Push-in terminal PT 2.5	0.14 mm ² ...2.5 mm ² flexible AWG24 – AWG14 rigid
stripping length	8 mm...10 mm
Dimensions (w x h x d)	12.5 x 80 x 98 mm
Mass	approx. 52 g
Approvals	UL 1059, File # E335289

Schematic diagram

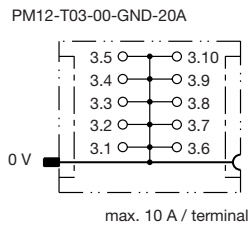

4

REX12 Electronic Circuit Protector

Accessories

EM12-T00-300-GND-40A supply module centre/right – 0V – GND

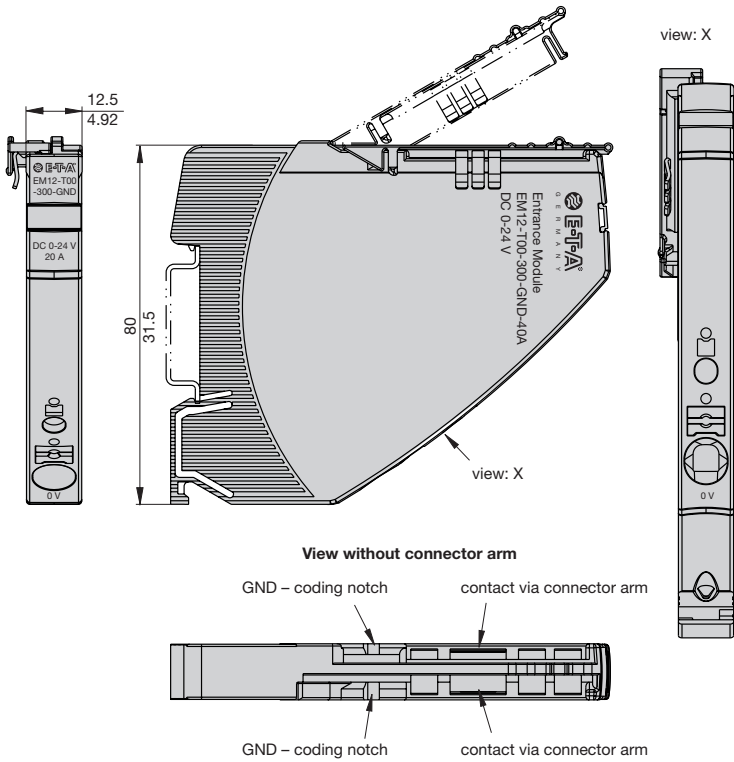

Technical data

Please observe general data of REX / EM / PM	
Operating voltage U_0	DC 24 V (0 ... 30 V)
Operating current I_B	max. load 40 A
line terminal	0 V – GND
Push-in terminal PT 10	0.5 mm ² ... 1.0 mm ² flexible AWG24 – AWG8 rigid
stripping length	18 mm
Dimensions (w x h x d)	12.5 x 80 x 98 mm
Mass	approx. 45 g
Approvals	UL 1059, File # E335289

Schematic diagram

EM12-T00-300-GND-40A

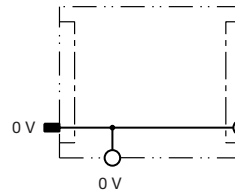

REX12 Electronic Circuit Protector

Accessories

PM12-T01-00-LOAD-20A potential module – LOAD (10-way, 1 x supply, 9 x LOAD)

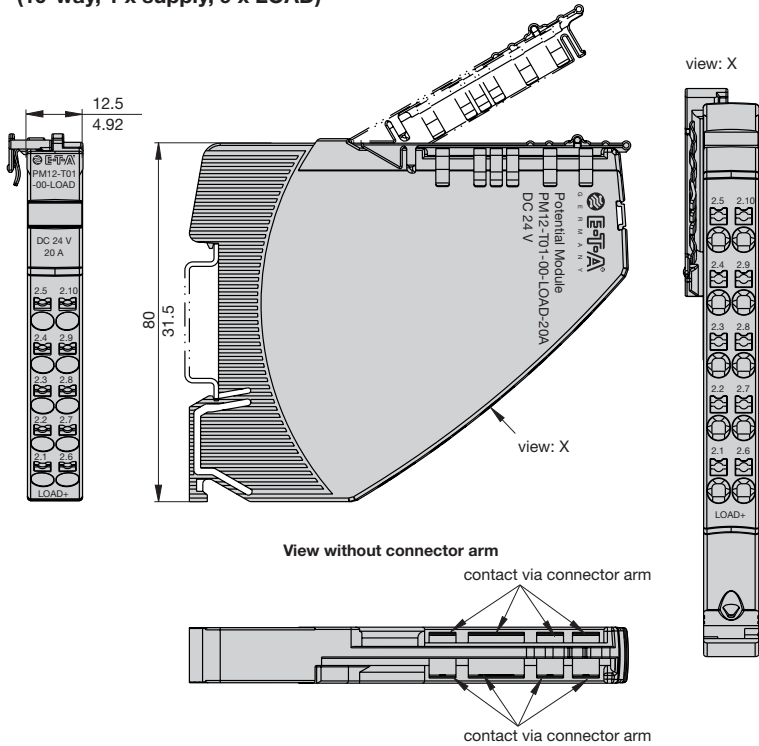

Technical data

Please observe general data of REX / EM / PM	
Operating voltage U_B	DC 24 V (18...30 V)
Operating current I_B	max. load 20 A
Insulation co-ordination	0.8 kV / pollution degree 2
Screw terminals	LOAD+
Push-in terminal PT 2.5	0.14 mm ² ...2.5 mm ² flexible AWG24 – AWG14 rigid
stripping length	8 mm...10 mm
Dimensions (w x h x d)	12.5 x 80 x 98 mm
Mass	approx. 52 g
Approvals	UL 1059, File # E335289

Schematic diagram

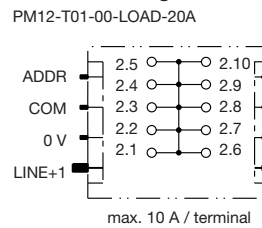

PM12-T02-00-LOAD-20A potential module – LOAD (2 x 5-way, 1 x supply and 4 x LOAD each)

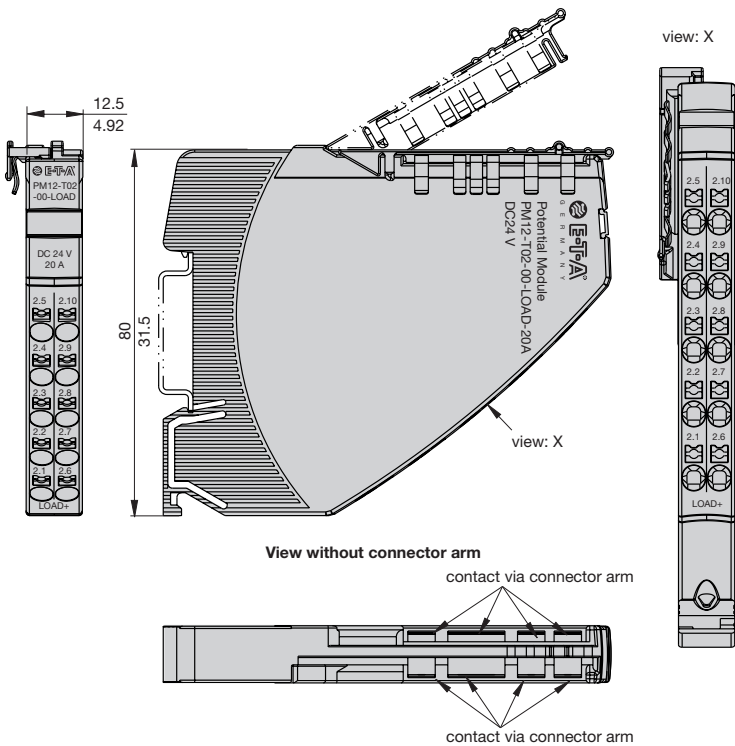

Technical data

Please observe general data of REX / EM / PM	
Operating voltage U_B	DC 24 V (18...30 V)
Operating current I_B	max. load 20 A
Insulation co-ordination	0.8 kV / pollution degree 2
Screw terminals	LOAD+
Push-in terminal PT 2.5	0.14 mm ² ...2.5 mm ² flexible AWG24 – AWG14 rigid
stripping length	8 mm...10 mm
Dimensions (w x h x d)	12.5 x 80 x 98 mm
Mass	approx. 52 g
Approvals	UL 1059, File # E335289

Schematic diagram

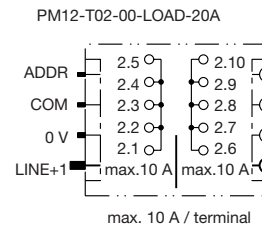

ET-A[®] REX12 Electronic Circuit Protector

Accessories

EM12-T00-100-LINE-40A supply module centre/right – LINE, LINE connected

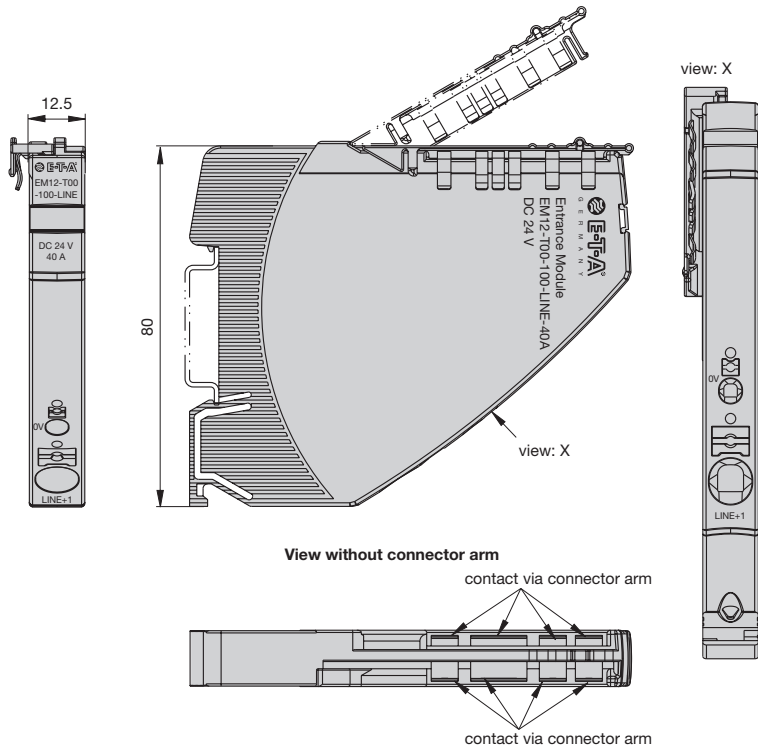

Technical data

Please observe general data of REX / EM / PM	
Operating voltage U_B	DC 24 V (18...30 V)
Operating current I_B	max. load 40 A
Insulation co-ordination	0.8 kV / pollution degree 2
Screw terminals LINE+1	
Push-in terminal PT 10	0.5 mm ² ...10 mm ² flexible AWG24 – AWG8 rigid
stripping length	18 mm
Screw terminals 0 V	
push-in terminal PT 2.5	0.14mm ² ...2.5mm ² flexible AWG26 – AWG14 rigid
Stripping length	8 mm ... 10 mm
Dimensions (w x h x d)	12.5 x 80 x 98 mm
Mass	approx. 52 g
Approvals	UL 1059, File # E335289

Schematic diagram

EM12-T00-100-LINE-40A

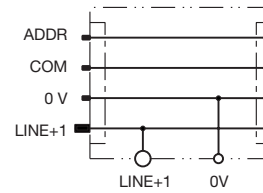

EM12-T00-200-LINE-40A supply module centre/LINE, LINE separated

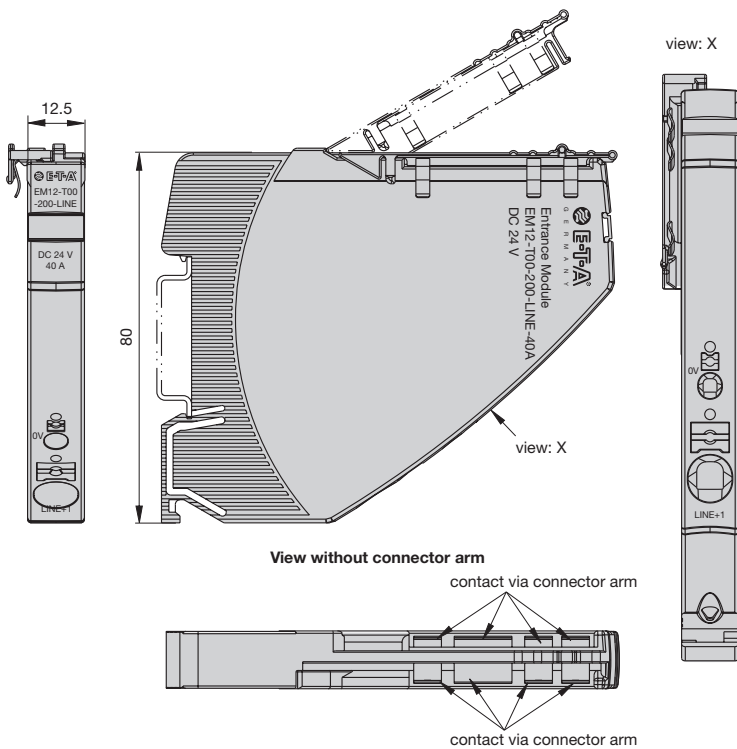

Technical data

Please observe general data of REX / EM / PM	
Operating voltage U_B	DC 24 V (18...30 V)
Operating current I_B	max. load 40 A
Insulation co-ordination	0.8 kV / pollution degree 2
Screw terminals LINE+1	
Push-in terminal PT 10	0.5 mm ² ...10 mm ² flexible AWG24 – AWG8 rigid
stripping length	18 mm
Screw terminals 0 V	
Push-in terminal PT 2.5	0.14mm ² ...2.5mm ² flexible AWG24 – AWG14 rigid
stripping length	8 mm...10 mm
Dimensions (w x h x d)	12.5 x 80 x 98 mm
Mass	approx. 52 g
Approvals	UL 2367, File # E306740; cULus508listed, File # E492388

Schematic diagram

EM12-T00-200-LINE-40A

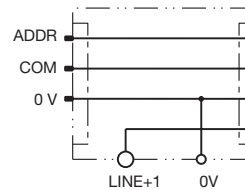

ET-A[®] REX12 Electronic Circuit Protector

Accessories

Label
 Marking area 6 x 10 mm
 Part number Y 307 942 61

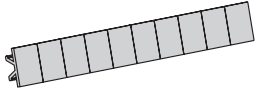

Note: Please use 2 strips per EM12, PM12 or REX12 module

Application example: EM12-T ... with REX12-TAx... and PM12-...

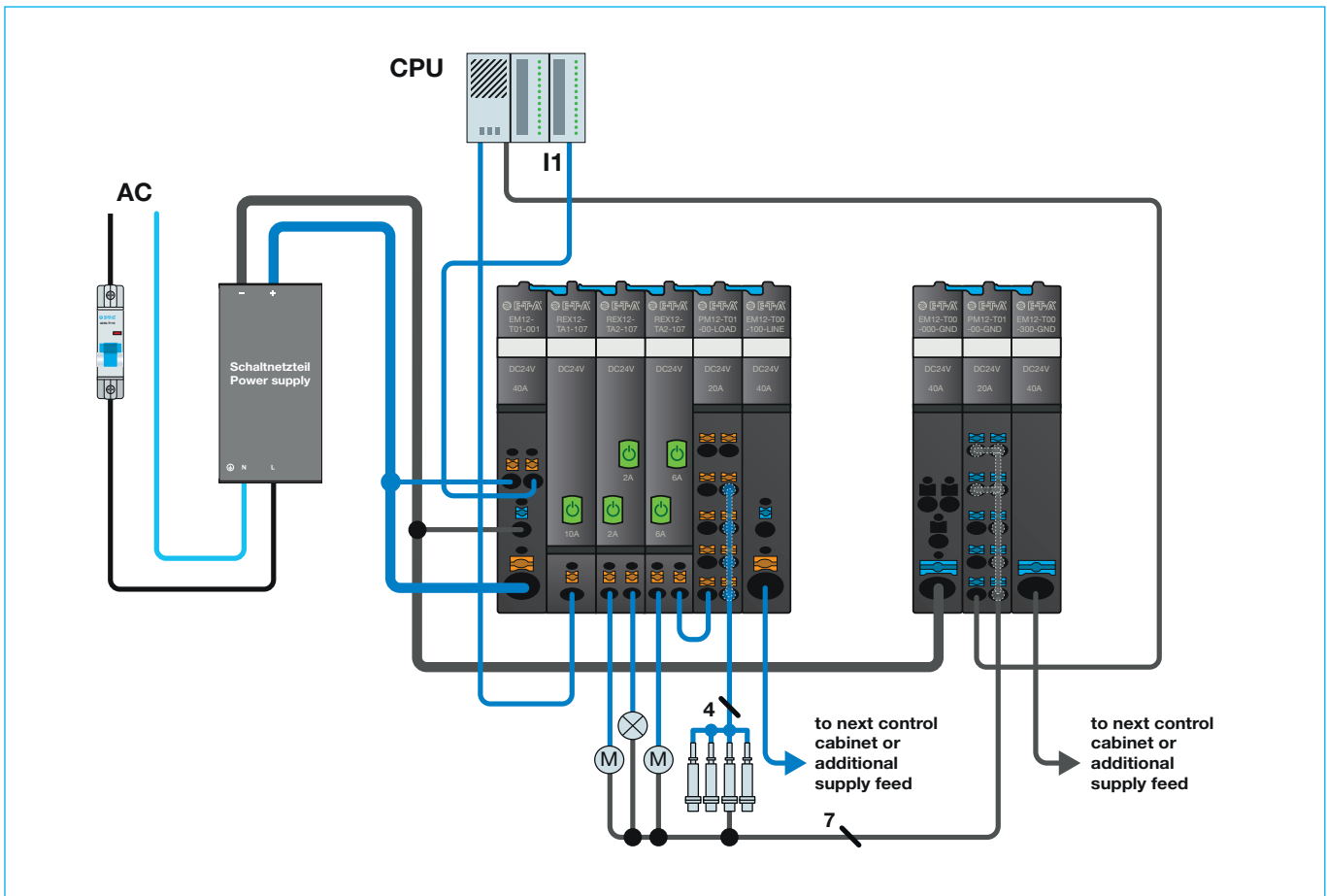

4



SCATTERGOOD & JOHNSON LTD

ELECTRICAL ENGINEERING & FLUID CONTROL DISTRIBUTORS

Est.1899

At Scattergood & Johnson Ltd, we pride ourselves on being a technical distributor to specialist industries.

Working with a range of quality product suppliers across a number of specialist markets, we are not your average 'box shifter' - we are your technical and supply chain partner.

We fully support every product we sell - for free! Our internal team and external sales engineers can answer any product or application question, no matter the complexity.

Backing up this technical ability is a range of 50,000+ products available from stock for nationwide next day delivery (same day if required!), or you can collect what you need from any of our trade counters around the UK.

Select your specialist interest below to learn more about how we can help.



Online, In Branch and On the Road - Scattergood & Johnson Ltd, there when you need us.

www.scatts.co.uk