

RTK DA170 range

MTL intrinsically safe LED clusters

- **ATEX Certified Ex II 1G, EEx ia IIC T4**
- **Available in six super-bright colours**
- **Suitable for all zones and gases**
- **11 year life expectancy**
- **Tough impact-resistant IP65 housing**
- **Low current (20mA)**
- **Matching pushbuttons and selector switches available**
- **Two clusters operable from a single IIC power source**



Reliable, high brightness visual indication for hazardous areas.

The RTK DA170 range of LED clusters provides visual on/off indication of process conditions in hazardous and safe areas. Available in six super-bright colours – red, green, yellow, amber, blue and white – they are standard 22.5mm diameter and seal to IP65 to the panel door.

All colours are matched for equal brightness and all are current limited to 20mA with an integral regulator.

In hazardous areas it is possible to combine LEDs from a single IS

interface, two for IIC interfaces and four with a IIB interface. The standard LED Cluster can also be supplied fully mounted in stainless steel boxes ready for immediate mounting on-site.

With the LED's lower power consumption, lower heat dissipation and far greater life expectancy the DA170 is an ideal standard indicator for safe and hazardous areas alike.

RTK DA170

October 2016

FEATURES & BENEFITS

Colours

The DA170 range of LED clusters is available in six superbright colours including a true white LED. Colours are red, green, yellow, amber, blue and white.

Low current consumption

The complete DA170 range features an integral current regulator to limit the current to 20mA, all colours are matched to obtain consistent brightness across the range including white and blue.

Simple connections

To avoid any wiring problem on site all the LED clusters have a unique bi-polar input so can be connected to the supply either way around.

Use in hazardous areas

The typical applications shown below illustrate some of the possible methods of connecting the LED. The way they can be used is extremely varied with numerous means of powering the device and interfacing to third party equipment such as the IS Relays, IS Annunciators and displays.

Lens style

The lens is designed to provide the best high intensity, diffused illumination to ensure the maximum visibility in all ambient light conditions. The tough plastic lens will allow side viewing as standard to aid operators.

Interfaces and systems

We manufacture a complete range of zener barrier and IS isolators that can be used to power the LED clusters and provide interfaces to trigger the LEDs. Intrinsically safe alarm and display systems can be designed and constructed to suit individual customer requirements.

Special mounting

We have a vast range of experience in supplying LED clusters pre-mounted, and, if required, prewired to terminals. This can comprise anything from a simple standalone stainless steel enclosure to complex alarm mimics. Please contact the sales office for a detailed quotation.

Simple installation

It is a simple job to mount the DA170 LED clusters on any panel door. The lens simply drops through an industry standard 22.5mm diameter hole and the body is screwed securely from the rear. This provides a seal to the panel of IP65.

Matching components

As shown opposite, the LED clusters can be supplied with a wide range of matching pushbuttons and selector switches. These all comply to the standard classification of 'simple apparatus' as defined in EN50014.

Alarm applications

As Eaton is a major supplier of industrial alarm systems and components, the DA170 range of LED clusters can be linked into either the LN1000 IS alarm annunciator or safe area mounting alarm annunciator systems. This method of operation will provide the clearest method of indicating alarm information within a Zone 1 hazardous area.

Labelling

Two accessories can be supplied with the LEDs, pre-engraved labels and a plastic label holder.

TYPICAL SYSTEM CONFIGURATIONS

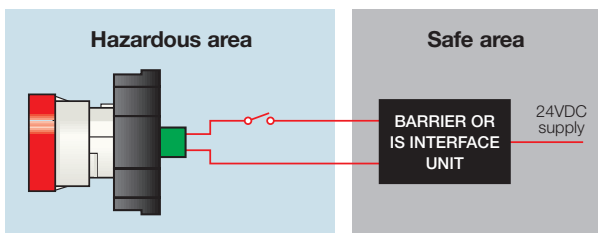

Single Cluster System: IIC Gas Group

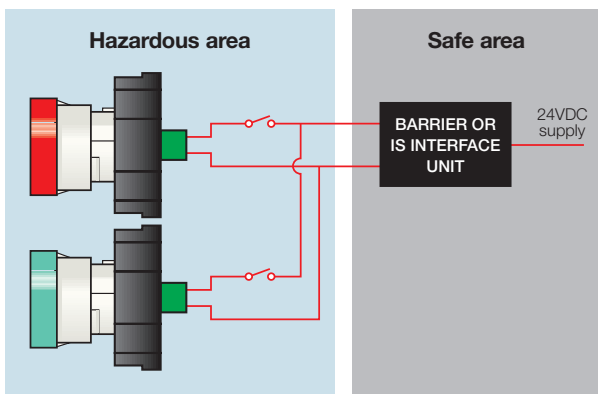

Double Cluster System: IIC Gas Group

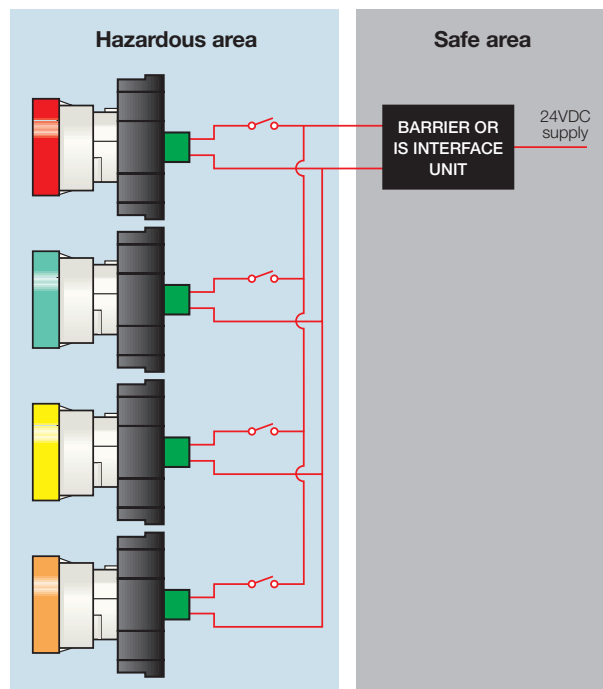

Four Cluster System: IIB Gas Group

RTK DA170

October 2016

TECHNICAL SPECIFICATION

Certification

ATEX certified to EN50014:1997,
EN50020:1994 and EN50284:1999
Group II, Category 1G, EEx ia IIC T4
(Ta -20°C to +60°C)

Location

Zones 0, 1 or 2. Gas Group IIC, IIB or IIA.
Temp Class up to T4

Certificate No.

BAS02ATEX1311

Safety parameters

Ui = 40V
Pi = 1.2W (max ambient temp. = 60°C)
Pi = 1.3W (max ambient temp. = 40°C)
Ci = Li = 0

The device can be powered from an EEx ia IIC certified interface with output parameters lower than those shown above

Supply

14-26VDC, current 20mA

Recommended interfaces

Zener Barriers: MTL7728+
IS Isolators: MTL5052

Environment

Operating Temperature: -20 to 60°C
Storage Temperature: -20 to 80°C
Humidity: 0-95% RH, non condensing

Protection

IP65 from the front, IP20 from the rear

Construction

Housing and Mouting Collar
- Polyamide 6.6/reinforced fibreglass FR4
Lens - Polycarbonate

Connections

Raising clamp terminals suitable for
2.5mm² cable

Compliance

Immunity to EN61000-6-2:2001

Accessories

DA658: Label Holder
DA659: interchangeable label

LED CLUSTER DIMENSIONS

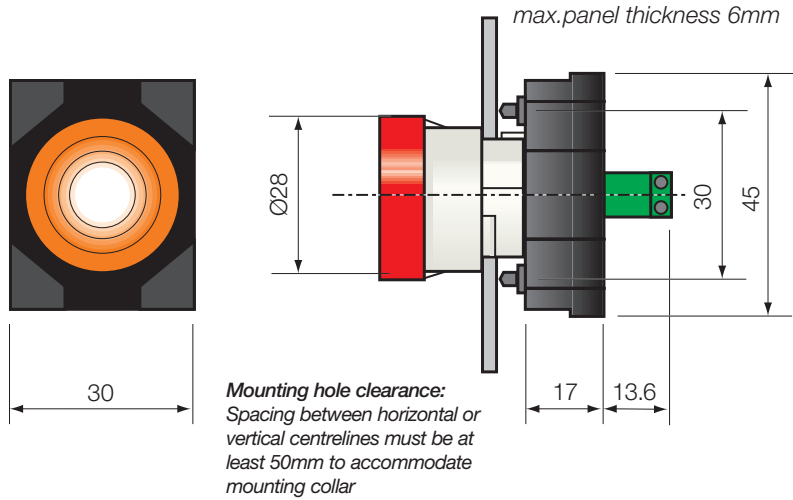

MATCHING SWITCHES AND PUSHBUTTONS

In addition to the standard LED Clusters, Eaton can provide a complete matching range of pushbuttons, selector switches and emergency-stop buttons. These can be selected using the following order code, taking note of the limitations as listed in the additional information panel.

Most of the pushbuttons and selector switches can be supplied in either illuminated or non-illuminated versions so your complete intrinsically safe control panel can have a consistent appearance.

The illuminated versions contain a certified BA9s LED Lamp Type P861 this is suitable for use in Zone 1 or 2 hazardous area, see separate datasheet.



ORDER CODE

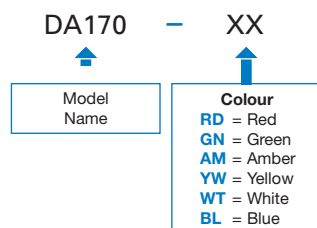

RTK DA170

October 2016

TECHNICAL SPECIFICATION FOR ILLUMINATED PUSHBUTTONS

Certification

ATEX certified to EN50014:1997 and EN50020:2002
Group II, Category 2G, EEx ia IIC T4
(Ta -20°C to +60°C)

Location

Zones 1 or 2. Gas Group IIC, IIB or IIA.
Temp Class up to T4

Certificate No.

Kema03ATEX1021X

Safety Parameters

Ui = determined by li and Pi
li = 2A
Pi = 1W
Ci = Li = 0

The device can be powered from an EEx ia IIC certified interface with output parameters lower than those shown above.

Supply

With suitable certified interface
18-35VDC, current 20mA

Recommended Interfaces

Zener Barriers: MTL7728+
IS Isolators: MTL5025

Environment

Operating temperature: -20 to 60°C
Storage temperature: -20 to 80°C
Humidity: 0-95% RH, non condensing

Compliance

Immunity to EN61000-6-2:2001
Emissions to EN61000-6-4:2001

Additional Information

1. Illumination is not available on emergency-stop pushbuttons
2. All the pushbuttons are momentary except the emergency-stop pushbuttons
3. Non-illuminated rotary selector switches are only available in black
4. Illuminated selector switches are available with a clear lens only
5. The maximum number of contacts is nine on non-illuminated units and six on illuminated versions

PUSHBUTTON DIMENSIONS

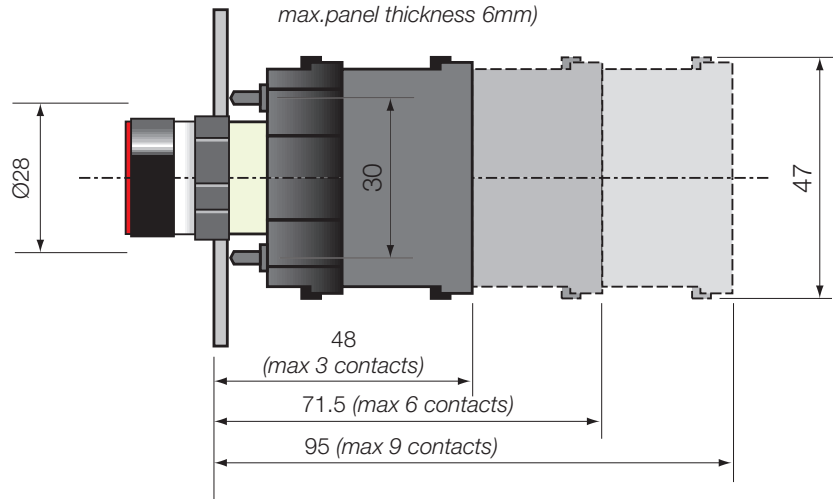

ORDER CODE

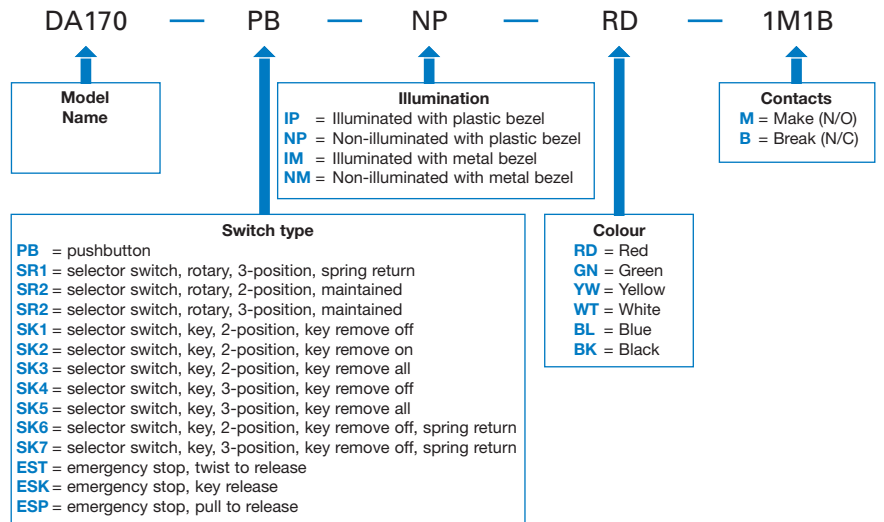

Eaton Electric Limited,
Great Marlings, Butterfield, Luton
Beds, LU2 8DL, UK.
Tel: + 44 (0)1582 723633 Fax: + 44 (0)1582 422283
E-mail: rtkenquiry@eaton.com
www.mtl-inst.com

© 2016 Eaton
All Rights Reserved
Publication No. EPS RTK DA170 Rev 4 111016
October 2016

EUROPE (EMEA):
+44 (0)1582 723633
mtlenquiry@eaton.com

THE AMERICAS:
+1 800 835 7075
mtl-us-info@eaton.com

ASIA-PACIFIC:
+65 6645 9864 / 6645 9865
sales.mtlsing@eaton.com

The given data is only intended as a product description and should not be regarded as a legal warranty of properties or guarantee. In the interest of further technical developments, we reserve the right to make design changes.



SCATTERGOOD & JOHNSON LTD

ELECTRICAL ENGINEERING & FLUID CONTROL DISTRIBUTORS

Est.1899

At Scattergood & Johnson Ltd, we pride ourselves on being a technical distributor to specialist industries.

Working with a range of quality product suppliers across a number of specialist markets, we are not your average 'box shifter' - we are your technical and supply chain partner.

We fully support every product we sell - for free! Our internal team and external sales engineers can answer any product or application question, no matter the complexity.

Backing up this technical ability is a range of 50,000+ products available from stock for nationwide next day delivery (same day if required!), or you can collect what you need from any of our trade counters around the UK.

Select your specialist interest below to learn more about how we can help.



Online, In Branch and On the Road - Scattergood & Johnson Ltd, there when you need us.

www.scatts.co.uk