

RTK P861

MTL intrinsically safe LED lamp

- ATEX certified to Ex II 2G Ex ia IIC T4
- Available in six super-bright colours
- Suitable for zones 1 & 2
- 11 year life expectancy
- Two lamps operable from a single IIC power source
- Can be supplied as a complete assembly or a simple certified LED lamp
- Intensity matched to provide equally super-bright performance for all colours



For use in pilot lights and illuminated pushbuttons.

The RTK P861 LED lamp provides visual on/off indication of process conditions in both safe and hazardous areas. Available in a choice of six super-bright colours (red, orange, yellow, green, blue and white), they are ideally suited for use as part of a panel mounting indicator or illuminated pushbutton assembly.

The P861 itself is a standard BA9s intrinsically safe LED lamp which can be supplied as part of a pilot light or illuminated pushbutton or alternatively supplied separately to be used in any suitable standard switch or lamp assembly.

With the LED lamp being current limited to take a maximum of only 20mA, it is possible to drive two lamps from a single IIC interface without any effect on the brightness.

RTK P861

October 2016

TECHNICAL SPECIFICATION

Colours

The P861 range of LED Lamps are available in six super-bright colours. Colours are red, orange, yellow, green, blue and white.

High reliability

All LED lamps are designed to provide a minimum of 100,000 hours service life.

Low current consumption

All LED lamps operate at 20mA or less and feature integral current limiting to maintain consistent brightness over the operating range of the voltage supply.

Use in hazardous areas

In hazardous areas the LED lamps must be powered through suitable intrinsically safe isolators or barriers. Up to two LED lamps can be driven from a single IIC interface.

Configuration

Easy to replace or change the colour of a panel indicator. Access is from the front of the panel and no tools are required. Simply unscrew the lens and replace the BA9s LED lamp.

Certification

ATEX certified to EN60079-0:2006 and EN60079-11:2007

Group II, Category 2G, Ex ia IIC T4 (Ta-20°C to 60°C)

Location

Zones 1 or 2. Gas Group IIC, IIB or IIA, Temp Class up to T4

Certificate no.

KEMA07ATEX0204X

Safety parameters

Pi = 1W

Ii = 2A

Ci = 0nF

Li = 0mH

Ui = Pi/Ii for a supply circuit with nonlinear current limiting

Ui = 4Pi/Ii for a supply circuit with linear current limiting

The device must be powered from an Ex ia IIC certified interface with output parameters lower than those shown above.

Supply

With suitable certified interface 18-35VDC, current 20mA.

Recommended interfaces

Zener Barriers: MTL7728P+
IS Isolator: MTL5521

Environment

Operating temperature: -20°C to 60°C
Storage temperature: -20°C to 80°C
Humidity: 0-95% RH, non condensing

Compliance

Immunity to EN61000-6-2:2005
Emissions to EN61000-6-4:2007

ILLUMINATED PUSHBUTTON AND PILOT LIGHT

The P861 LED Lamp can be supplied as an integral part of the DA170 Range of Illuminated Pushbuttons. These are industry standard 22mm pushbuttons which can be supplied in a range of different formats such as rotary, non-illuminated and emergency stop.

See separate datasheet for full details.

Construction

Housing/mounting collar – Polyimide6.6 and FR4 fibreglass
Lens – Polycarbonate

Protection

IP65 when panel mounted, IP20 from the rear.

Connections

Screw terminals rated to IP20 minimum for cables from 0.5 to 2.5mm².

Mounting

Lamp – BA9s bulb holder
Pushbutton, pilot light – through 22.5mm diameter hole.

BA9s LED lamp

The P861 LED lamp itself has a standard BA9s fitting and, when installed in accordance with the certificate and relevant standards, can be used in any suitable pilot light or pushbutton.

ORDER CODE

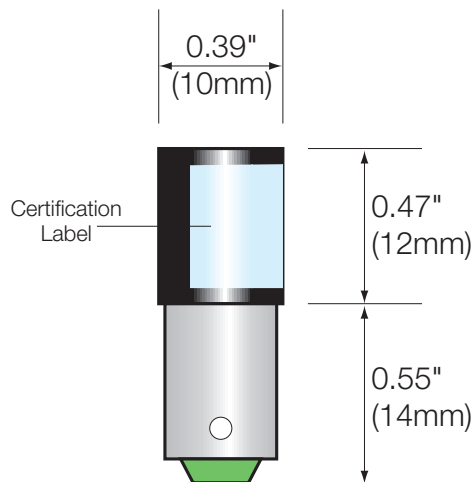
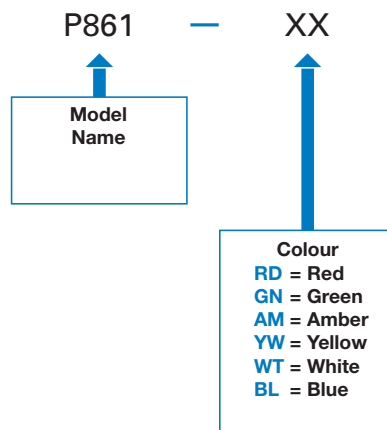

Eaton Electric Limited,
Great Marlings, Butterfield, Luton
Beds, LU2 8DL, UK.
Tel: + 44 (0)1582 723633 Fax: + 44 (0)1582 422283
E-mail: rtkenquiry@eaton.com
www.mtl-inst.com

© 2016 Eaton
All Rights Reserved
Publication No. EPS RTK P861 Rev 3 111016
October 2016

EUROPE (EMEA):
+44 (0)1582 723633
mtlenquiry@eaton.com

THE AMERICAS:
+1 800 835 7075
mtl-us-info@eaton.com

ASIA-PACIFIC:
+65 6645 9864 / 6645 9865
sales.mtlsing@eaton.com

The given data is only intended as a product description and should not be regarded as a legal warranty of properties or guarantee. In the interest of further technical developments, we reserve the right to make design changes.



SCATTERGOOD & JOHNSON LTD

ELECTRICAL ENGINEERING & FLUID CONTROL DISTRIBUTORS

Est.1899

At Scattergood & Johnson Ltd, we pride ourselves on being a technical distributor to specialist industries.

Working with a range of quality product suppliers across a number of specialist markets, we are not your average 'box shifter' - we are your technical and supply chain partner.

We fully support every product we sell - for free! Our internal team and external sales engineers can answer any product or application question, no matter the complexity.

Backing up this technical ability is a range of 50,000+ products available from stock for nationwide next day delivery (same day if required!), or you can collect what you need from any of our trade counters around the UK.

Select your specialist interest below to learn more about how we can help.



Online, In Branch and On the Road - Scattergood & Johnson Ltd, there when you need us.

www.scatts.co.uk